

APPLICABLE MODELS

***PIPER PA-32-260, PA-32-300, PA-32S-300, PA-32R-300,
PA-32RT-300, PA-32RT-300T.***

**FLAP, AILERON, FLAP/FUSELAGE
AND STABILATOR GAP SEALS.**

**INSTALLATION MANUAL
ISSUE DATE 05/05/84**

KNOTS 2U, LTD.
709 AIRPORT ROAD
BURLINGTON, WI 53105
262 763-5100
WWW.KNOTS2U.COM

REVISIONS

REV.	DATE	PAGE (S)	EFFECT
A	11/15/90	6 & 8	DELETED REVISION DATE FROM INDIVIDUAL PAGES, ADDED REVISION PAGE, CORRECTED END SPACE CLEARANCE ON STABILATOR SEAL.
B	06/01/97	COVER , REVISION, 10.	CHANGE NAME AND ADDRESS
C	05/05/98	ALL	CHANGED RIVNUTS TO STANDARD FROM COUNTERSUNK, GENERAL CLEANUP

INTRODUCTION

PERFORMANCE FLIGHT TESTING.

1. The rigging of the aircraft should be checked before the installation, and any changes to the rigging should be performed before the flight testing.
2. The flight testing must be done with the aircraft loaded to the same gross weights, and as far as possible under the same atmospheric conditions. Early morning or late evening will usually provide the smoothest air.
3. Under identical conditions, a good indication of performance change is the “indicated” airspeed. Example, if you climb to 5,000 feet and find after stabilizing at maximum cruise you have 24 inches of manifold pressure, the altitude that gives you 24 inches of manifold pressure on the after flights will be close to the same density altitude as the early flights. Since the airspeed indicator is a pressure reading device, if the air pressure is creating an identical manifold pressure reading, and the air speed indicator is reading higher, it is obvious airspeed has increased. A density altitude indicator will help to verify the same flight conditions.
4. Another method is timing across 2 parallel roads between which you know the exact distance. (The further apart, the less chance for error) Stabilize the aircraft perpendicular to the roads and fly straight across the first. Punch the timer at the exact point where the leading edge of the wing crosses the road and maintain a constant heading at 90 degrees to the road. After maintaining constant altitude and power settings, punch the clock again when the leading edge crosses the second road. Repeat the procedure back and forth several times and record all resulting times. Calculate the ground speed for each flight in each direction and average for the number of flights. Repeat after the mod installation.

GAP SEAL TRIVIA

The improvement in aerodynamics provided by the gap seals results from providing a smooth surface for airflow, together with a pressure barrier to keep the high pressure air on the bottom of the wing from leaking up through to the low pressure air on the top. The proper fit of the gap seals with minimum end spacing at the ends and between the seals is very important. When the aileron is in the cruise position you should be able to pull the trailing edge of the gap seal downward, and when let go it should snap back into place. With the flaps in the up position the flap seal should just touch the flap. When the flap is deployed down, it should pull away from the seal allowing airflow over the flap.

TABLE OF CONTENTS

	<u>PAGE</u>
SECTION 1.0 =LEFT AND RIGHT AILERON GAP SEALS=.....	1
1.1 -P/N OA, OUTBOARD AILERON SEAL LOCATING-.....	1
1.2 -P/N CA, CENTER AILERON SEAL LOCATING-.....	1
1.3 -P/N LIA, LEFT INBOARD SEAL LOCATING -.....	1
1.4 -ENLARGING MOUNTING HOLES FOR P/N OA & LIA-...	2
1.5 -ENLARGING MOUNTING HOLES FOR P/N's CA-.....	2
1.6 -FINAL INSTALLATION OF AILERON SEALS-.....	2
1.7 -FINAL CHECK-.....	2
1.8 -INSTALLING RIGHT SIDE AILERON SEALS-.....	2
SECTION 2.0 =LEFT AND RIGHT FLAP GAP SEAL INSTALLATION=.....	2
2.1 - P/N LIF, LEFT INBOARD SEAL LOCATING-.....	2
2.2 - P/N OF, OUTBOARD FLAP SEAL LOCATING-.....	3
2.3 - ENLARGING HOLES-.....	3
2.4 - FINAL INSTALLATION OF FLAP SEALS-.....	3
2.5 - RECONNECTING FLAP-.....	3
2.6 - RIGHT SIDE INSTALLATION-.....	3
2.7 -PAPERWORK-.....	3
SECTION 3.0 =PARTS LIST=.....	4
SECTION 4.0 =LEFT AND RIGHT FLAP/FUSELAGE GAP SEALS=.....	5
4.1 -P/N LFF LEFT FLAP/FUSE SEAL INSTALLATION-.....	5
4.2 -RIGHT SIDE INSTALLATION-.....	5
4.3 -PAPERWORK-.....	5
4.4 -PARTS LIST-.....	5
SECTION 5.0 =STABILATOR GAP SEAL INSTALLATION=.....	6
5.1 -DISCONNECTING TRIM TAB ACTUATOR ARM-.....	6
5.2 -RIVET REMOVAL-.....	6
5.3 -INSTALLING SEAL-.....	6
5.4 -DRILLING RIVET HOLES-.....	6
5.5 -FINAL CLEANUP-.....	6
5.6 -RIVETING P/N T28, STABILATOR SEAL-.....	6
5.7 -REBALANCING STABILATOR-.....	6
5.8 -PAPERWORK-.....	6
5.9 -STABILATOR GAP SEAL PARTS LIST-.....	6
SECTION 6.0 =DETAIL #1=.....	7
SECTION 7.0 =DETAIL #2=.....	8
SECTION 8.0 =SUPPLEMENTAL TYPE CERTIFICATE=.....	9
SECTION 9.0 =MAINTENANCE MANUAL=.....	10
SECTION 10.0 =MAINTENANCE MANUAL DETAIL DRAWING=.....	11
SECTION 11.0 =NOTCHED DETAIL DRAWING=.....	12

NOTE #1:

THIS MANUAL DESCRIBES THE INSTALLATION OF THE *KNOTS 2U* FLAP, AILERON, FLAP/FUSE SEAL KIT. THE APPROPRIATE PIPER SERVICE MANUAL FOR YOUR AIRCRAFT SHOULD BE USED IN CONJUNCTION WITH THIS MANUAL. THE BEST TIME TO PAINT THE PARTS IS BEFORE INSTALLING, OR AFTER ALL HOLES ARE DRILLED AND BEFORE FINAL INSTALLATION. PRIMING IS NOT NECESSARY ON THE ALUMINUM PARTS AS THEY ARE PRIMED WITH A ZINC CHROMATE WASH PRIMER. SURFACES SHOULD BE "SCUFFED" WITH A SCOTCHBRITE AND PAINTED. COVER THE CHAFF STRIP ON THE TRAILING EDGE OF THE SEALS WITH MASKING TAPE BEFORE PAINTING.

NOTE #2:

SOME EARLY PA-32 AILERONS HAVE EXTERNAL STIFFENER RIBS WHICH PROTRUDE ABOVE THE AILERON SKIN RATHER THAN BELOW, REQUIRING "NOTCHED" AILERON GAP SEALS. FOR SUCH AIRCRAFT THE APPROPRIATE NOTCHED SEAL PART NUMBER APPEARS IN THE "ALTERNATE PART NUMBERS" SECTION IN THE PARTS LIST, AND AT THE END OF EACH PARAGRAPH IN THE AILERON SECTION OF THIS MANUAL. IT IS IMPORTANT TO CHECK THE LOCATION OF THE NOTCHES IN RELATIONSHIP TO THE RIBS ON THE AILERON THROUGH IT'S FULL UP AND DOWN TRAVEL WHILE EACH SEAL IS BEING LOCATED. NOTCHES CAN BE FILED AS NECESSARY TO ASSURE PROPER CLEARANCE OF THE RIBS. REFER TO NOTCH DETAIL ON PAGE 12 FOR INSTALLING NOTCHED SEALS.

SECTION 1.0 =LEFT AND RIGHT AILERON GAP SEALS=**1.1 -P/N OA, LEFT OUTBOARD AILERON SEAL LOCATING-**

(DETAIL #1) Referencing the appropriate Piper Service Manual, remove the left aileron from aircraft. Position P/N OA 1/16" inboard of the wingtip, with the center of the break radius even with the bottom of the wing. (NOTE: THE BOW IN THE AILERON SEAL WILL CAUSE THE CENTER PART OF THE SEAL TO BE SLIGHTLY BELOW THE BOTTOM WING SURFACE. THIS IS DESIRED) Drill clearance holes in the seal flange to allow the seal to clear any existing rivets that prevent the seal from laying flush against the spar. Drill # 40 holes through pilot holes and cleco seal in place. (Notched seal P/N LOA-C)

1.2 -P/N CA, CENTER AILERON SEAL LOCATING-

(DETAIL # 1) Locate a P/N CA 1/32" from the inboard edge of P/N OA just installed, and the center of the break radius even with the bottom of the wing. Drill clearance holes in the seal flange to allow the seal to clear any existing rivets that prevent the seal from laying flush against the spar. Drill # 40 holes through pilot holes and cleco seal in place. Repeat procedure for next inboard seal P/N CA (Notched seal P/N LCOA-C & LCIA-C)

1.3 -P/N LIA, LEFT INBOARD SEAL LOCATING-

(DETAIL # 1) Locate a P/N LIA 1/32" from the inboard edge of P/N CA just installed, and the center of the break radius even with the bottom of the wing. Drill clearance holes in the seal flange to allow the seal to clear any existing rivets that prevent the seal from laying flush against the doubler. Drill # 40 holes through pilot holes and cleco seal in place. The most outboard hole, the one not on the doubler will be away from the spar slightly. Use (2) P/N AN960-6 washers as a spacer behind the seal. (Notched seal P/N LIA-C)

NOTE #3:

AT THIS POINT WITH THE SEALS HELD TEMPORARILY IN PLACE, HOLD AILERON IN POSITION AND RUN THROUGH ITS FULL TRAVEL. IF THE RIVETS ON THE LEADING EDGE OF THE AILERON ARE RUBBING AGAINST ANY SEAL, THE SEAL MAY BE REMOVED AND FURTHER BOW ADDED. ALSO ASSURE THAT THE SEALS ARE MAKING PROPER CONTACT WITH THE AILERON. WITH THE AILERON IN THE NEUTRAL POSITION THE TRAILING EDGE OF THE SEALS SHOULD BE PUTTING LIGHT PRESSURE ON THE AILERON. IF ANY ARE NOT MAKING CONTACT THEY CAN BE BENT UP SLIGHTLY UNTIL CONTACT IS MADE.

1.4 -ENLARGING MOUNTING HOLES FOR P/N OA & LIA-

(DETAIL #1) Enlarge attachment holes in wing for the outboard gap seal P/N OA and the inboard gap seal P/N LIA to a #15 hole size. Use Alodine or equivalent to corrosion proof the holes and Install P/N A6-75 Rivnuts in the (3) holes for P/N OA and (1) in the most outboard hole for P/N LIA. Install P/N A6-120 Rivnuts in the (3) holes through the doubler for P/N LIA. Drill the pilot holes in the gap seal to a # 20 hole size.

1.5 -ENLARGING MOUNTING HOLES FOR P/N's CA-

(DETAIL #1) Enlarge attachment holes in wing for the center gap seals P/N's CA to a #27 hole size. Also enlarge the pilot holes in the P/N's CA to a #27 hole size. Deburr all holes in gap seals and airframe, remove all shavings from aircraft and corrosion proof all holes with Alodine or equivalent. The seals may be painted at this time.

1.6 -FINAL INSTALLATION OF AILERON SEALS-

(DETAIL #1) Install P/N OA and LIA using (7) AN526-632-R10 screws. Under P/N LIA on the most outboard hole, use (2) P/N AN960-6 Washers as a spacer. Install P/N CA s using (16) P/N CR3243-4-2 Cherry Max Rivets.

1.7 -FINAL CHECK-

Per the appropriate Piper Service Manual reinstall aileron and check seals for proper contact. Move aileron through its full up and down travel to confirm no contact is made with seal except at the trailing edge.

1.8 -INSTALLING RIGHT SIDE AILERON SEALS-

Repeat steps 1.1 thru 1.7 on right wing. All part numbers will be the same except an "R" designation will replace the "L" designation.

SECTION 2.0 =LEFT AND RIGHT FLAP GAP SEAL INSTALLATION=**NOTE #4:**

IF KNOTS 2U FLAP HINGE FAIRINGS ARE BEING INSTALLED ON THE AIRCRAFT SOME LABOR SAVINGS CAN BE ACCOMPLISHED BY INSTALLING THEM BEFORE THE FLAP GAP SEALS.

2.1 - P/N LIF, LEFT INBOARD SEAL LOCATING-

(DETAIL #1) Per the appropriate Piper Service Manual fully lower flaps and at the inboard end remove the clevis bolt and spacer from the flap actuating rod terminal end. Retain parts for reinstallation. The flap will now swing down and allow room for installation. Position P/N LIF with the end tab against the fuselage and 5/8" flange against rear of the wing. Position the bottom of the seal flush with the bottom of the wing skin. There are (2) existing rivets on the fuselage where the P/N LIF meets it, these rivets may be drilled out and the holes used to attach P/N LIF. (If these holes do not allow enough edge distance, drill (2) new holes while observing edge distances) With seal properly located using the pilot holes mark and drill the (2) outboard holes in the rear wing spar to a #40 hole size. Cleco seal in place.

2.2 -P/N OF, OUTBOARD FLAP SEAL LOCATING.

(DETAIL #1) Using 1/32" edge spacing place (1) P/N OF just outboard of P/N LIF just installed. Position the bottom of the seal flush with the bottom of the wing skin. Drill clearance holes in the seal flange to allow the seal to clear any existing rivets that prevent the seal from laying flush against the spar. Drill # 40 holes through pilot holes and cleco seal in place. Repeat procedure for next outboard seal P/N OF.

2.3 -ENLARGING HOLES-

Enlarge attachment holes in wing to a #27 hole size. Also enlarge the pilot holes in the P/N's OF and LIF to a #27 hole size. Deburr all holes in gap seals and airframe, remove all shavings from aircraft and corrosion proof all holes with Alodine or equivalent. The seals may be painted at this time.

2.4 -FINAL INSTALLATION OF FLAP SEALS-

(DETAIL #1) With gap seals held in place move flap up and down and check for proper contact and alignment with seals. Rivet flap seal parts in place using (56) P/N CR3243-4-2 Cherry Max Rivets.

2.5 -RECONNECTING FLAP-

Per the appropriate Piper Service Manual reinstall clevis bolt and spacer in flap actuating rod terminal end. Run flap up and down several times to check seal alignment.

2.6 -RIGHT SIDE INSTALLATION-

Repeat steps 2.1 thru 2.5 on right wing.

2.7 -PAPERWORK-

Perform paperwork (337 and log book entries). Place Supplemental Type Certificate and KNOTS 2U, LTD. Maintenance Manual with log books.

Aileron Gap Seal & Hardware= 1.21 lbs.

Flap Gap Seals & Hardware= 1.00 lbs
Arm = 129 inches.

=SECTION 3.0 =PARTS LIST=

P/N	QTY.	DESCRIPTION
OA	2	OUTBOARD AILERON SEAL
CA	4	CENTER AILERON SEAL
LIA	1	LEFT INBOARD AILERON SEAL
RIA	1	RIGHT INBOARD AILERON SEAL
OF	4	OUTBOARD FLAP SEAL
LIF	1	LEFT INBOARD FLAP SEAL
RIF	1	RIGHT INBOARD FLAP SEAL
CR3243-4-2	88	ROUNDHEAD CHERRYMAX RIVET
AN526-632-R10	14	ROUNDHEAD SCREW
A6-75	8	RIVNUT
A6-120	6	RIVNUT
AN960-6	4	FLAT WASHER

ALTERNATE PART NUMBERS (SEE NOTE #2)

P/N	QTY.	DESCRIPTION
<i>ROA-C</i>	<i>1</i>	<i>RIGHT OUTBOARD AILERON SEAL</i>
<i>RCOA-C</i>	<i>1</i>	<i>RIGHT CENTER OUTBOARD AILERON SEAL</i>
<i>RCIA-C</i>	<i>1</i>	<i>RIGHT CENTER INBOARD AILERON SEAL</i>
<i>RIA-C</i>	<i>1</i>	<i>RIGHT INBOARD AILERON SEAL</i>
<i>LOA-C</i>	<i>1</i>	<i>LEFT OUTBOARD AILERON SEAL</i>
<i>LCOA-C</i>	<i>1</i>	<i>LEFT CENTER OUTBOARD AILERON SEAL</i>
<i>LCIA-C</i>	<i>1</i>	<i>LEFT CENTER INBOARD AILERON SEAL</i>
<i>LIA-C</i>	<i>1</i>	<i>LEFT INBOARD AILERON SEAL</i>

SECTION 4.0 = LEFT & RIGHT FLAP/FUSELAGE GAP SEALS =**4.1 -P/N LFF, LEFT FLAP / FUSE SEAL INSTALLATION-**

(DETAIL #1) With Flap full up place P/N LFF, Left Flap / Fuselage Gap Seal on top of inboard end of flap against fuselage so that the seal covers the space between the inboard edge of the flap and the fuselage. Position so that the forward end of the curved portion is even with the trailing edge of the flap, and so that it makes solid contact with the top of the flap surface. If rivets interfere with the seal it may be trimmed to clear. With seal properly located, and observing all edge distances, mark (3) hole locations, (1) at each end of the seal flange and (1) in the center. If existing hardware falls under a hole location, the hole may be relocated. Drill #40 hole locations at these points and temporarily attach seal using (3) P/N TRA 4X1/4 screws. Lower and raise the flap several times to confirm proper contact and no binding. Mark the seal where it overhangs the bottom of the aircraft. Excess material should be trimmed off and the seal deburred. Enlarge holes to a #27 hole size. Deburr holes and corrosion proof with Alodine or equivalent. Seal may be painted at this time. Rivet seal in place using (3) P/N CR3243-4-2 Cherry Max rivets or equivalent.

4.2 - RIGHT SIDE INSTALLATION-

Repeat step 4.1 on right side.

4.3 - PAPERWORK-

Perform paperwork (337 and log book entries). Place Supplemental Type Certificate and KNOTS 2U, LTD. Maintenance Manual with log books.

Flap/Fuselage Seal & Hardware= .14 lbs.
Arm = 129 inches

4.4 PARTS LIST-

P/N	QTY.	Description
LFF	1	LEFT FLAP/FUSELAGE SEAL
RFF	1	RIGHT FLAP/FUSELAGE SEAL
CR3243-4-2	6	CHERRY MAX RIVET

SECTION 5.0 = STABILATOR GAP SEAL INSTALLATION=

5.1- DISCONNECTING TRIM TAB ACTUATOR ARM-

Remove the (4) bolts connecting the Stabilator trim tab actuator arm. Move the left and right tabs upward as far as free travel allows.

5.2 - RIVET REMOVAL-

Remove existing #4 rivets from the lower rear spar of the Stabilator, Cleco as you go.

5.3 - INSTALLING SEAL -

(DETAIL #2) Remove Clecos and insert gap seal P/N T28 on left side between lower spar flange and lower Stabilator skin. Position seal 5/8 inch (nominal) inward between spar and skin with chafe strip side aft and facing up toward trim tab. Seal should be positioned so that there is a 1/8 inch gap between the inboard edge of the seal and the trim tab actuator base. Seal may then be trimmed on the outboard end so that it does not extend further outboard than the trim tab. Lower trim tab so it rests against seal. At the very outboard end of seal some models have a roundhead rivet on the trim tab that will interfere with flush fit of Stabilator Seal. This rivet should be removed and replaced with a countersunk rivet of the same size. Repeat procedure on right side.

5.4 - DRILLING RIVET HOLES -

With seal in proper location and using rivet holes in skin as a guide drill # 30 holes in P/N T28 Stabilator Seal, Cleco as you go. With seal drilled and Clecoed, lower trim tab and confirm proper contact of seal against trim tab. With the trim tab in the neutral position it should lightly contact the control surface. Move trim tab through its full travel and confirm there is no excess binding. If binding occurs or seal does not meet with the trim tab in the neutral position, the seal may be bent slightly up or down.

5.5 - FINAL CLEANUP-

Remove the gap seal from aircraft and clean all drill shavings from area. Deburr all holes and trimmed areas and corrosion proof with Alodine or equivalent. Seal may be painted at this time.

5.6 -RIVETING P/N T28, STABILATOR SEAL-

Cleco gap seals in place. Rivet every other hole using AN 470AD-4-4 rivets while leaving every other cleco in place. After 1/2 of the rivets are in place, remove the other clecos and finish riveting seals.

5.7 -REBALANCING STABILATOR-

It is the responsibility of the installer to assure that the Stabilator is properly balanced per the appropriate Piper Service Manual. If any painting is done to the seals or stabilator, it must be done before balancing. Check for full travel after balancing and that any weights added to balance arm do not restrict stabilator travel.

5.8 -PAPERWORK

Perform paperwork (337 and log book entries). Place Supplemental Type Certificate and KNOTS 2U, LTD. Maintenance Manual with log books.

Stabilator Seals= .42 lbs.
 Arm = Per appropriate Piper Service Manual

5.9 -STABILATOR GAP SEAL PARTS LIST-

P/N	QTY.	DESCRIPTION
T28	2	STABILATOR GAP SEAL
AN470AD-4-4	67	RIVET

FLAP AND AILERON SEAL INSTALLATION, STRAIGHT WING MODELS

(FLAP REMOVED FOR CLARITY)

(AILERON REMOVED FOR CLARITY)

FLAP FUSE SEAL
TOP VIEW

AFT ↑

P/N LFF

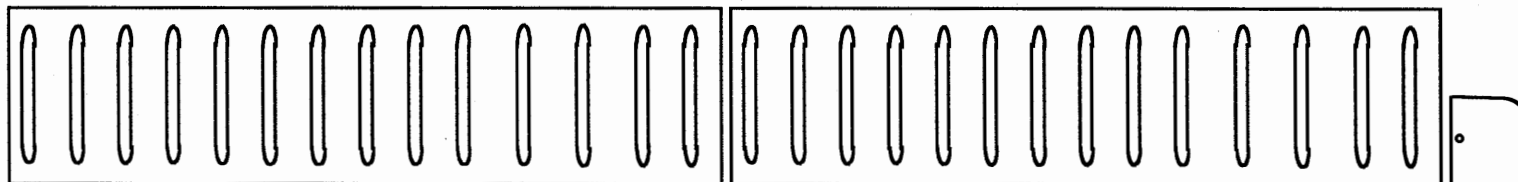

P/N LIF P/N OF P/N OF P/N LIA P/N CA P/N CA P/N OA

TOP VIEW LEFT WING

FAA
APPROVED

NOV 09 1998

H. Mack-116c
CHICAGO AIRCRAFT
CERTIFICATION OFFICE
CENTRAL REGION

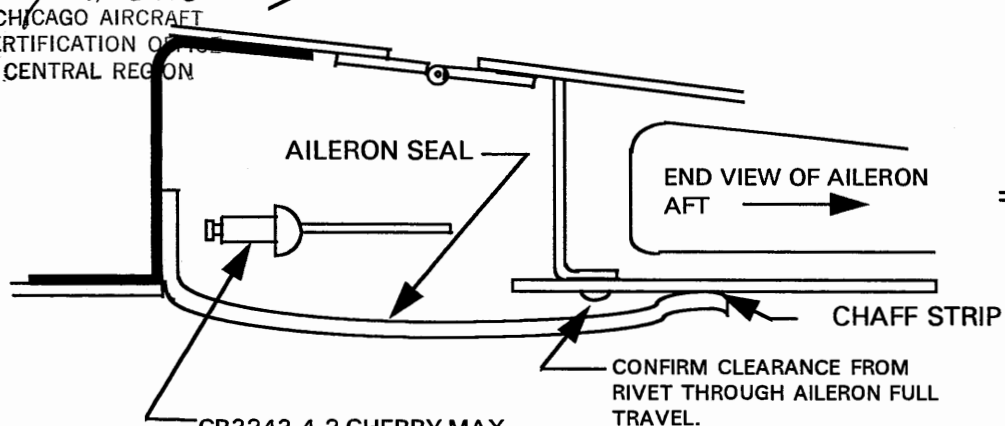

CR3243-4-2 CHERRY MAX RIVETS. P/N OA, RIA, & LIA USE A6K-75 OR A6K-120 RIVNUTS AND AN526-632-R10 SCREWS.

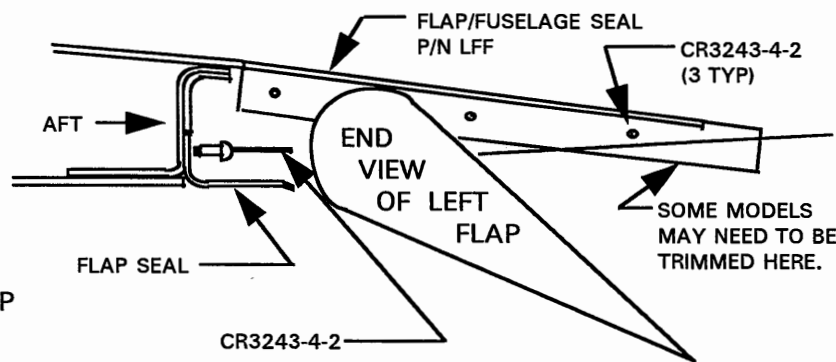

DATE	REVISION	PIPER PA-28 / 32	DRWG# 603D1
05/05/98	RIVNUT CHANGE / CLEANUP	05/30/90	DRAWN BY JMB
		KNOTS 2U, LTD.	NOT TO SCALE

DETAIL 1, PAGE 7.

PIPER PA-28 / 32 STABILATOR GAP SEAL INSTALLATION

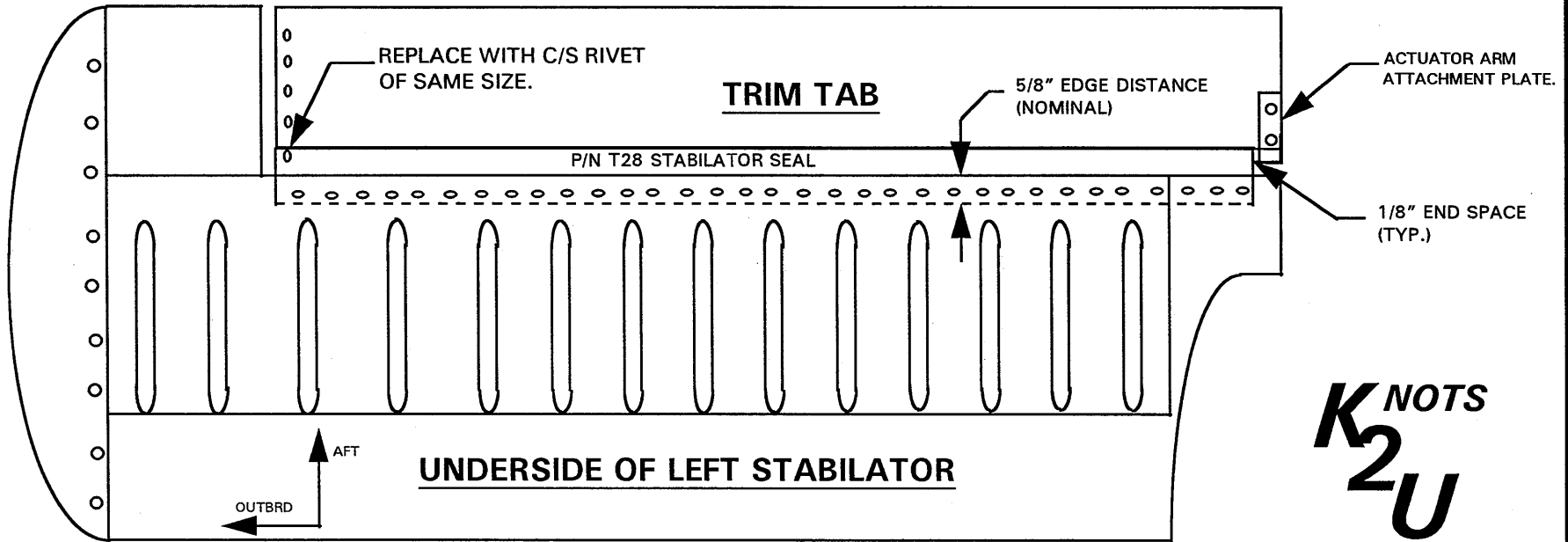

**KNOTS
2U**

FAA
APPROVED

NOV 09 1998
A. J. ...
CHICAGO AIRCRAFT
CERTIFICATION OFFICE
CENTRAL REGION

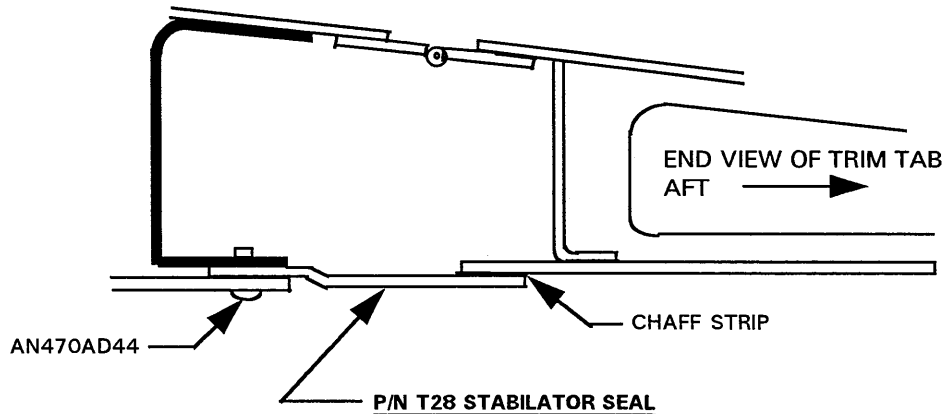

DETAIL #2

PAGE -8-

REV	DATE	EFFECT
A	05/05/98	ADD CS RIVET, CLEANUP
KNOTS 2U, LTD.		
3106 BIENEMAN ROAD - BURLINGTON, WI 53105		
DRAWING#		609D2
PIPER PA-28/32		05/30/90
DRAWN BY: JMB		NO SCALE

=SECTION 9.0 MAINTENANCE MANUAL=**KNOTS 2U, LTD.****PIPER PA-32****FLAP AILERON FLAP/FUSELAGE GAP SEALS****PART A. INSPECTION**

1. Daily inspection at preflight to ensure there is no binding of controls, bent gap seals, abrading of rivets or control surfaces, or broken parts.
2. When aircraft has been stored outside during snow or freezing conditions, a careful inspection should be made of the areas behind and under the seals for ice accumulations. If ice is found, which cannot be removed by careful brushing, the aircraft should be de-iced.
3. 100 hour inspections are suggested to check for abrading of rivets, control surfaces, and seals. Chafe tape should be inspected for peeling or excessive wear. Check all hardware and attachment of all seals.

PART B. MAINTENANCE

1. There are no special tools required to maintain the seals. Any tools needed are basic hand tools.
2. Maintenance of the Gap Seals is to keep the seal surface clean of oil and dirt, and the edge of the seal touching the control surface smoothly. If the Gap Seal appears to be abrading the control surface, 3M 5490 Teflon Tape, or equivalent, may be applied to the Gap Seal to act as a wear surface. The tape should be applied before further flight to prevent control wear.
3. If upon installation, or through wear, there is a warp in the seal or it lies unevenly, you may drill a #40 hole and cut the seal in a direction 90 degrees from the trailing edge. Drill the hole in the center of the warp, 1/2 inch from the trailing edge of the surface that the seal is attached to. The cut in the seal should be trimmed to give a slot 1/16th" wide, with parallel edges. The slots should be no closer than 6 inches from each other or the end of the seal. Refer to detail MM Detail, next page.
4. When aircraft is painted, care should be taken to prevent paint, paint remover, or solvents from contacting the Chafe Strip. If Chafe Strip is damaged, refer to PART B Paragraph 2 of this manual for replacement specifications.

PART C. BALANCING

1. If any change is made to the Horizontal Stabilator; if Chafe Strip is added, if slots are cut to relieve warping, or if the seals are painted, the Stabilator must be rebalanced.

PART D. CRACKING, DEFECTS, LOOSE RIVETS.

1. If cracks are found in a Gap Seal, stop drill the crack. If there are more than 3 cracks in a Gap Seal, the seal must be replaced.
2. If the Chafe Strip peels, 3M 5490 Teflon Tape, or equivalent, may be applied
3. If there are excessive bends or kinks in the seal, and the airflow over the control surface is disturbed, the seal must be replaced.
4. If seal rivets become loose you may drill the rivets and replace with the next size rivet.

EXAMPLE OF REPAIR OF WARPED GAP SEAL

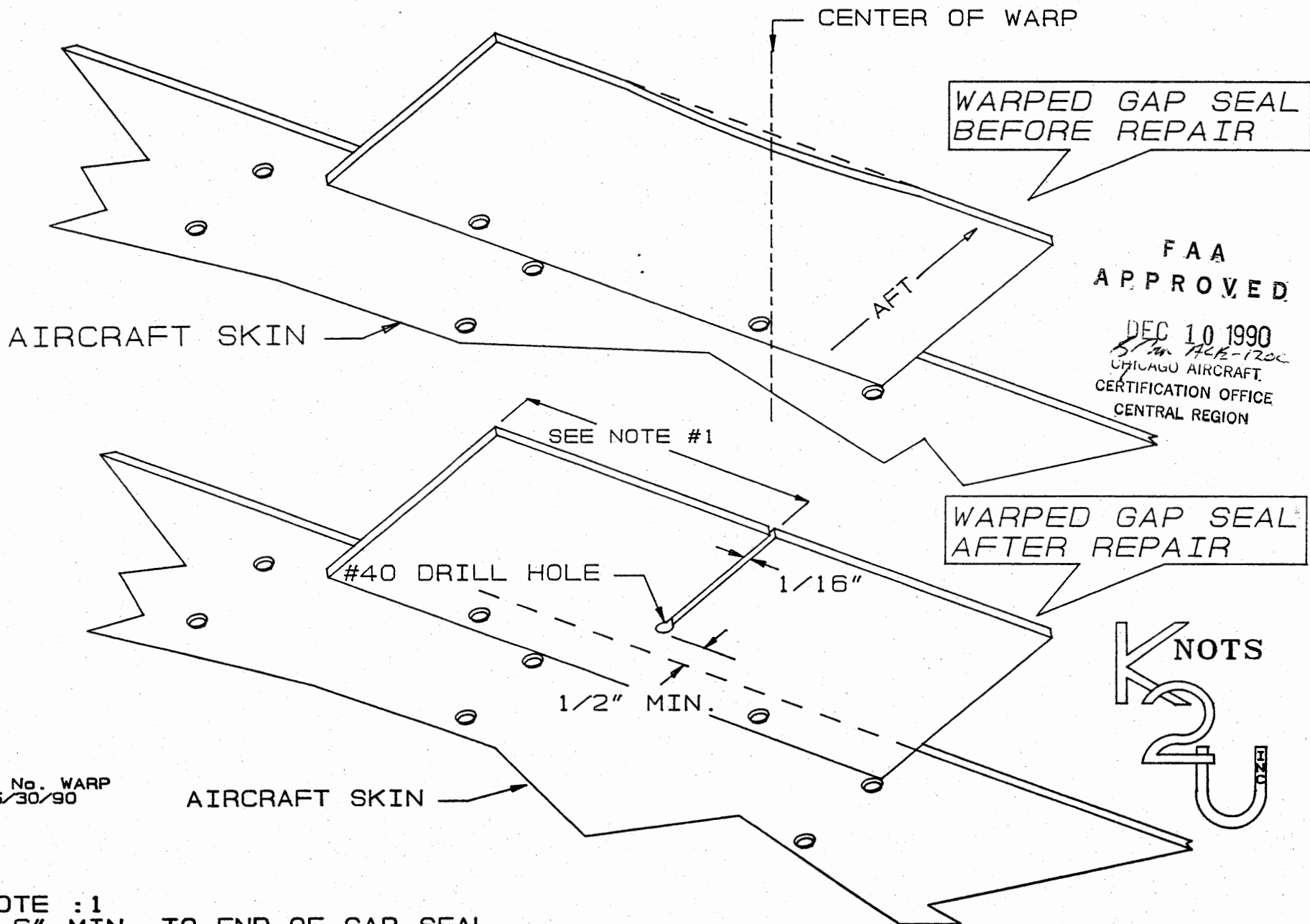

DWG No. WARP
05/30/90

NOTE : 1
6" MIN. TO END OF GAP SEAL
OR TO NEXT WARP REPAIR SLOT

NOTCHED AILERON GAP SEAL INSTALLATION DETAIL

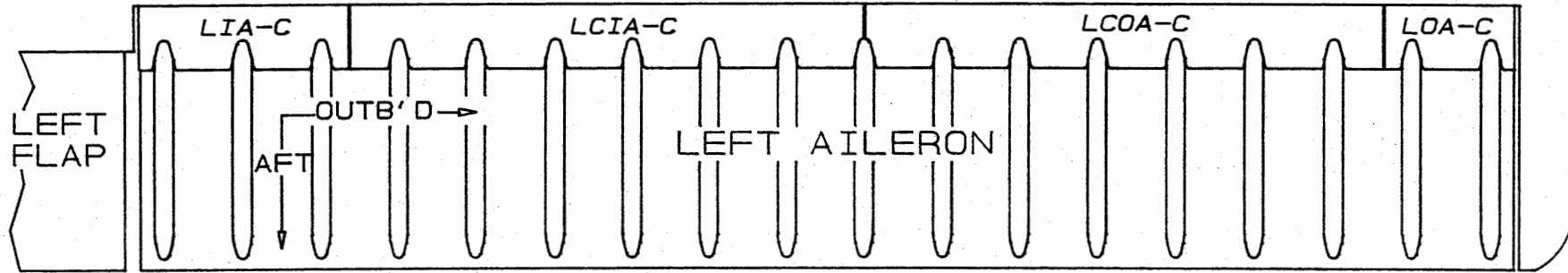

BOTTOM VIEW

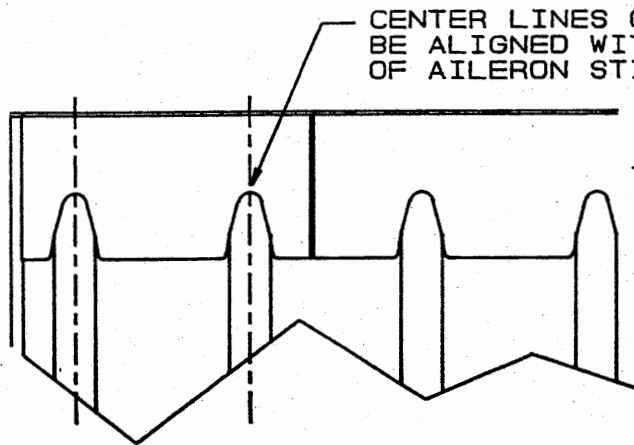
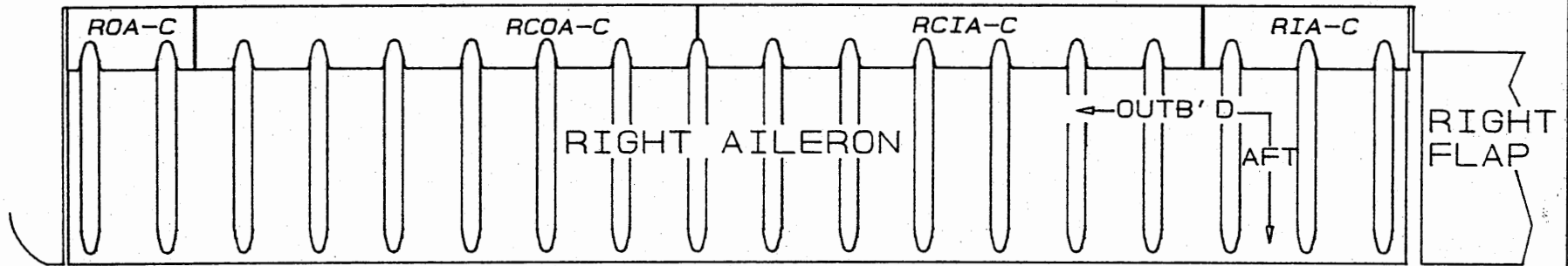

NOTCH ALIGNMENT
DETAIL

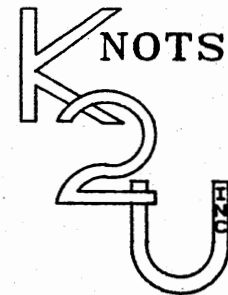

FAA
APPROVED

DEC 10 1990
BY *BTM* ACE-120C
CHICAGO AIRCRAFT
CERTIFICATION OFFICE
CENTRAL REGION

DWG. No. 2832NOT
05/30/90