

## Application Note 8501-088: Adding Protection When Switching Inductive Loads

Acromag manufactures products that are often used to switch inductive loads. For example, our digital outputs and alarm relays commonly drive inductive loads that include motor windings, solenoids, interposing relay coils, physical inductors, and even the load wiring itself. In all cases, we routinely recommend that protection be placed local to the inductive load being switched. For DC inductive loads, this usually takes the form of an added reverse-biased shunt diode placed right across the load terminals. We make this recommendation even when our switches may already incorporate similar protection inside the device. Often we are asked to justify the “inconvenience” of adding protection to the load by customers and some have even inferred that our switching devices must be weak because we make this recommendation. However, this is not an “Acromag thing”, but good practice for all inductive load switching applications. The purpose of this application note is to explain the importance of this added protection and how it works.

### Inductor Behavior

To help you understand why you should add this protection, we need to review some points about inductor behavior. You may recall being told things like “...the current through an inductor cannot change instantaneously”, “...inductors impede changes in current flow”, and “...inductors store energy”. Well, because the current in an inductor cannot change instantly, inductors will impede changes in current, and do indeed store energy. The stored energy in a charged inductor is not indefinite and its eventual discharge is precisely why you need to add protection to switched inductive load circuits. This is illustrated by the RL charging and discharging circuits shown in Figures 1 through 3.

### SIMPLIFIED LOW-SIDE SWITCHED INDUCTOR OR RELAY COIL (SINKING)

FOR AN INDUCTOR, THE VOLTAGE CAN CHANGE INSTANTLY IN TIME, BUT THE CURRENT THROUGH IT CHANGES MORE GRADUALLY.

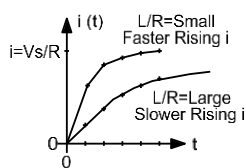

Note that the current rises more quickly to  $V_s/R$  with GREATER RESISTANCE.

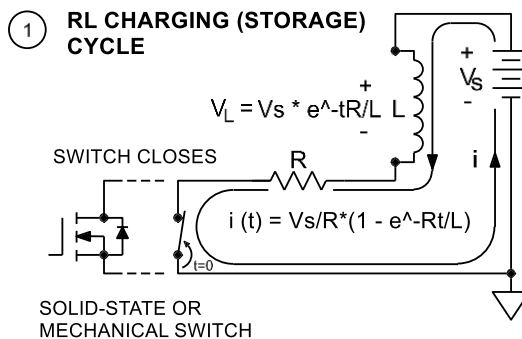
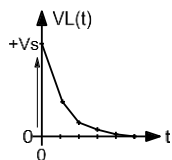

When the switch is closed, the inductor begins charging and initially acts like an OPEN circuit to DC and gradually becomes a SHORT circuit to DC. The current  $i$  rises from 0 to  $V_s/R$ , while the voltage drop in the inductor decreases from  $V_s$  to 0 (assuming an ideal coil resistance of 0 ohms).

The current  $i$  increases exponentially with time as  $i(t) = i_o * (1 - e^{-Rt/L}) = V_s/R * (1 - e^{-Rt/L})$ .

The exponential time constant is  $L/R$ . Refer to the Table at left and note the transition to steady state at  $i = V_s/R$  is nearly completed in roughly five time constants at  $i = 99.3\% i_o$  and  $V = 0.07\% V_s$ .

Note that during the charging phase,  $i$  increases by the storage factor. But later when the inductor discharges,  $i$  decays by the decay factor. During both the storage and decay phase, inductor voltage moves from  $V$  or  $-V$  towards 0 by the decay factor.

TIME CONSTANT	i STORAGE FACTOR ( $1 - e^{-Rt/L}$ )	V DECAY FACTOR ( $e^{-Rt/L}$ )
$t=L/R=1$	0.632 or 63.2% $i_o$	0.368 or 36.8% $V_s$
$t=L/R=2$	0.865 or 86.5% $i_o$	0.135 or 13.5% $V_s$
$t=L/R=3$	0.950 or 95.0% $i_o$	0.050 or 5.0% $V_s$
$t=L/R=4$	0.982 or 98.2% $i_o$	0.018 or 1.8% $V_s$
$t=L/R=5$	0.993 or 99.3% $i_o$	0.007 or 0.7% $V_s$

To keep things simple in our examples of Figures 1 to 3, we will assume an ideal inductor with 0 resistance, although the reality is that an inductor coil and the circuit wiring have some resistance that will individually drop portions of the applied voltage (i.e.  $V_L$  is never exactly 0V).

Refer to Figure 1 above that shows an “idealized” switched inductor during its “charging cycle” after a switch closes to allow a battery to charge the inductor. The inductor current is initially  $i=0$  and it rises exponentially to  $i=V_s/R$  according to  $i=V_s/R * (1 - e^{-Rt/L})$ . The inductor voltage is initially  $V_L = V_s$  and decays exponentially towards  $V_L=0$  according to  $V_L = L * di/dt = V_s * e^{-Rt/L}$ . The exponential inductor voltage drop is a result of its initially high varying resistance to changing current which opposes an increase in current from  $i=0$  to a steady state  $i=V_s/R$ , while the inductor voltage  $V_L$  decreases gradually from  $V_L=V_s$  to  $V_L=0$ .

In Figure 2, the switch has been closed for a time and the circuit has reached steady state with a constant current  $i=V_s/R$  and  $V_L \sim 0$ .

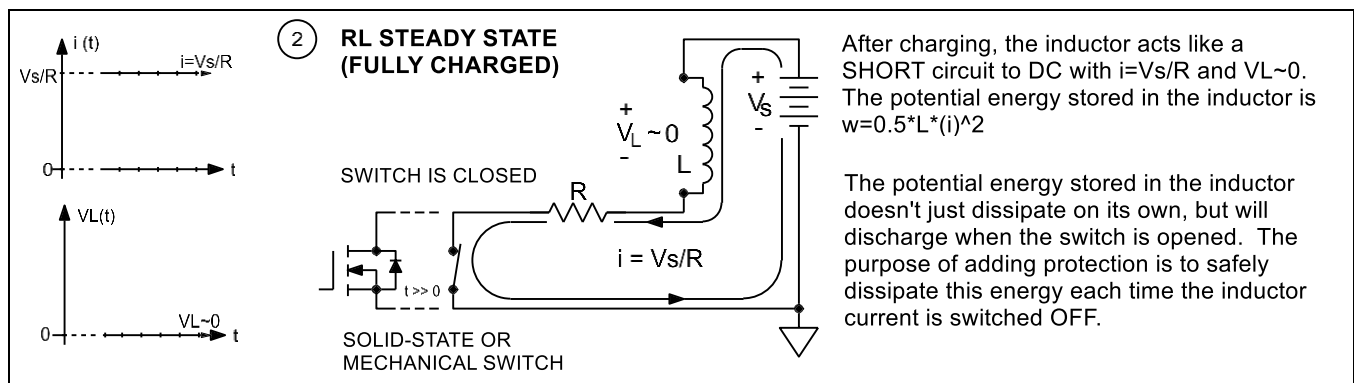

Now where this gets really interesting is to discover what happens when the current to a charged inductor is interrupted. The inductor initially resists a change in its current and must dissipate its stored energy before the current through it can adjust. Unless you take measures to steer discharge current and dissipate the stored energy safely, the discharge cycle can wreak havoc in your circuit. This is illustrated in Figures 3A and 3B.

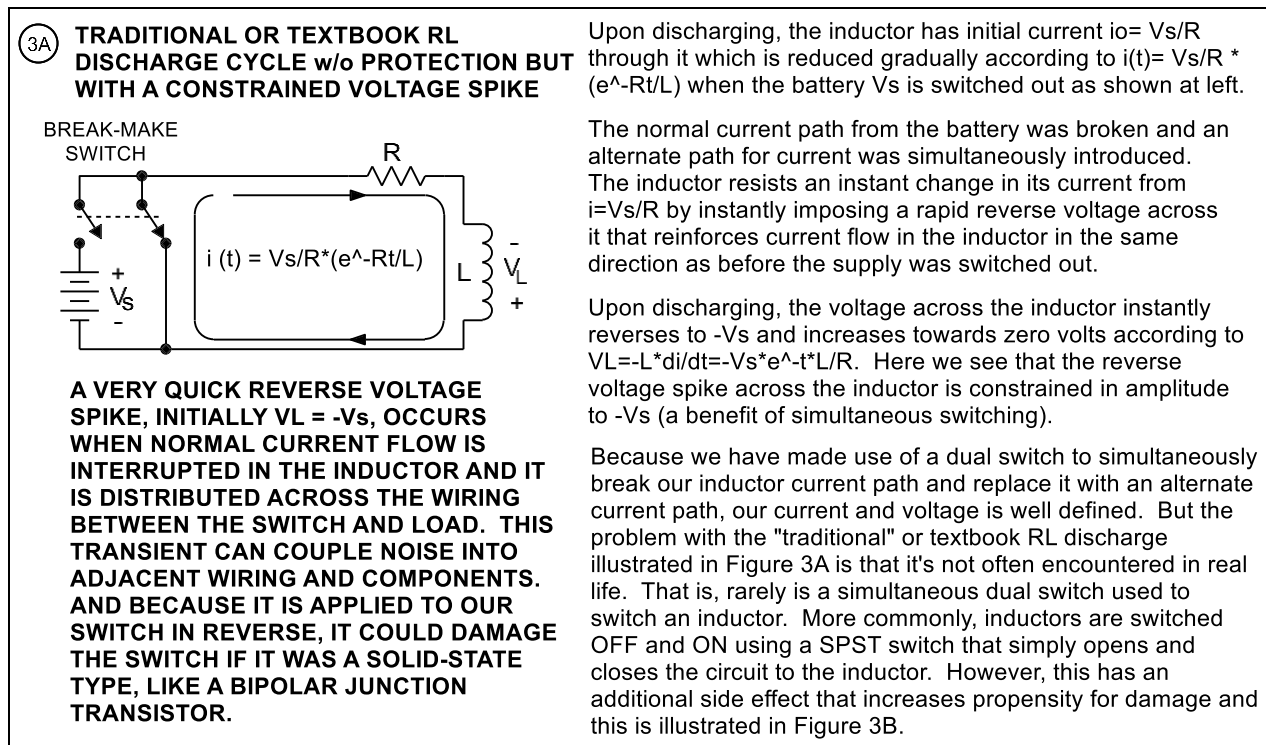

**Application Note: Adding Protection When Switching Inductive Loads**

In Figure 3A, the switch from the battery is suddenly opened, physically interrupting the steady state current path of  $i=V_s/R$ . The coil tries to maintain this current in itself by instantly flipping the polarity of its terminal voltage to  $-V_s$ , reinforcing the initial current through it in the original direction. This reverse inductor voltage gradually decays from  $V_L=-V_s$  towards  $V_L=0$  according to  $V_L = -L di/dt = -V_s * e^{-tR/L}$ . The current through the inductor decays exponentially in the same direction as the steady state current before the switch was opened, from  $i=V_s/R$  initially to  $i=0$  according to  $i=V_s/R * e^{-tR/L}$ . In Figure 3A, by using simultaneous switching to introduce an alternate path for the charged inductor current as we interrupt its normal path, we have constrained the reverse transient voltage  $V_L$  to the magnitude of the battery voltage  $V_s$ .

The traditional RL discharge cycle illustrated in Figure 3A has a great benefit in that it constrains the magnitude of the inductive transient spike  $V_L$  to  $-V_s$  and helps prevent arc'ing. A good concept on paper, but it has a big problem:

*A simultaneous DPDT or Break-Make dual switch is very difficult to implement. It is more likely that there would be a small gap time between the individual break and make switches that would result in a transient voltage spike greater than  $V_s$ , which could possibly drive an arc in the circuit. The inductor voltage spikes very quickly and gap time must be very fast or nearly 0.*

The reality is that inductive loads are not usually switched via simultaneous DPDT switches as shown in Figure 3A, but instead with SPST switches similar to Figure 3B. Although much easier to implement than Figure 3A, simply opening a steady state inductor circuit with a SPST switch as shown in Figure 3B has the additional negative consequence of spiking the reverse voltage  $V_L$  in the negative direction to whatever amplitude is required to complete the current path that reinforces the initial steady state inductor current prior to the switch opening.

**3B MORE COMMON OR "REAL-LIFE" RL DISCHARGE CYCLE w/o PROTECTION WHERE THE REVERSE  $V_L$  SPIKE IS NOT CONSTRAINED TO  $V_s$**

**THE REVERSE VOLTAGE SPIKE THAT RESULTS WHEN NORMAL CURRENT FLOW IS INTERRUPTED IN THE INDUCTOR IS DISTRIBUTED ACROSS THE WIRING BETWEEN THE SWITCH AND LOAD AND WILL INCREASE NOISE AND EMISSIONS. ITS AMPLITUDE IS LESS PREDICTABLE AND IT HAS THE POTENTIAL TO ARC OVER, AND POSSIBLY DAMAGE THE SWITCH AND ADJACENT COMPONENTS.**

As in Figure 3A, upon discharging, the inductor has initial current  $i_0 = V_s/R$  through it which is reduced gradually according to  $i = V_s/R * (e^{-Rt/L})$  when the switch is opened.

Similar to 3A, the current path from the battery was broken, but no alternate path for the discharge current was introduced in 3B. The inductor resists an instant change in its current from  $i=V_s/R$  by instantly imposing a rapid reverse voltage across it that reinforces current flow in the inductor in the same direction as before the switch opened.

Upon discharging, the voltage across the inductor instantly reverses to  $-V$  and increases towards or decays to zero volts according to  $V_L = -L * di/dt = -V * e^{-tR/L}$ , but the magnitude of  $V$  is less predictable in this case, as it's not constrained to  $-V_s$  as in Figure 3A.

Herein lies a greater problem than illustrated in Figure 3A. That is, because our charged inductor was simply open circuited, the rapid reverse voltage spike generated across the inductor is NOT constrained to an amplitude of  $-V_s$ . Rather, it will go to whatever reverse voltage amplitude is necessary to complete the current path.

That is, the reverse voltage will spike even to the point of arc'ing through air between the closest open conductors in the circuit path. The resultant current will decay from  $i=V/R$  along an alternate path of least resistance according to  $i(t) = -V/R * e^{-Rt/L}$  ( $V$  in this expression is not necessarily equal to  $V_s$ ).

This reverse voltage driven arc may occur at the switch contacts, between wires, or even inside the relay itself, potentially damaging circuitry or components.

**IMPORTANT:** In Figure 3B, the charged inductor is left open when the switch is opened (not recommended). This means that the reverse voltage spike developed across the inductor will go as high as necessary to cause the open coil energy to arc or flash-over in the circuit. This high reverse voltage spike, if left unconstrained, can do significant damage to any circuitry along the circuit path. For control via a mechanical switch, an arc may occur as the switch is being gapped open, eventually fouling its contacts, or the relay coil may arc over to metal inside the relay, like its armature. For a solid-state mosfet switch, the high voltage reverse spike can destroy the switch, although most mosfets actually include a source-drain diode to shunt this spike at the switch. In order to thwart increased emissions and possible circuit damage, you should always add protection local to the inductive load, or at least wire the switching circuit in such a way that inductor current is given an alternate safe discharge path when the reverse voltage  $V_L$  spikes across the inductor in an attempt to maintain current flowing at steady state the instant the switch is opened.

Without providing a method to squelch reverse switching transients and steer the stored inductor energy safely, it will instead be transmitted along the wiring between the switch and the load and can represent significant destructive energy that may damage or erode other components, like the solid-state mosfet or transistor switch driving it. It can also generate noise in adjacent circuits by radiating or inductively coupling its voltage spike into adjacent conductors, and even cause arcing across the contacts as they open. Over time, arcing contacts will become more resistive as burn-oxide forms on the contact surface, even to the point of eventual failure to make electrical contact. Likewise, the large reverse transients fed back to the switch may degrade or erode the switch, potentially causing leakage in the OFF state or eventual failure of a solid-state switch. So to extend the life of our switches and relays, lower noise and emissions, and protect adjacent equipment, we really need a method to curb the formation of these transients right at their source (right at the load).

**IMPORTANT POINT:** Consider that when the output switch or relay driving the inductive load turns OFF or opens, the normal current flow through the inductor is immediately interrupted and the sudden interruption of this current flow causes the inductor to spike a reverse voltage across itself of  $V_L = -L di/dt$ . The numerator “di” refers to the magnitude of current change and can represent a fairly large number in some applications, but it is ultimately limited to the application current itself. The denominator “dt” on the other hand is the time over which the current changed, and since it is switched OFF quite quickly, it represents a very small amount of time. This means  $di \div dt$  can equate to a fairly large magnifier acting on the inductance to produce  $V = -L*(di/dt)$ , which if not otherwise limited, can become quite large and will be applied in the opposite direction to normal current flow (and the normal IR drop across the inductor), as it tries to support the current flowing through the inductor in the same direction. We’ve stated that while the voltage across an inductor can change in an instant, the inductor current cannot change its magnitude or direction instantly. The current through the inductive load at the instant the current path is broken is normally equal to the current before the path was broken ( $i_o$ ) decaying exponentially with time according to  $i(t) = i_o * e^{-tR/L}$  ( $t$ =time since current turned off,  $L$ =inductance,  $R$ =series resistance of circuit). But for either scenario of Figures 3A or 3B, when the switch is opened to interrupt normal current flow,  $i(t)$  will always be limited in magnitude to  $i_o=V/R$ . While  $V$  is limited to  $V_s$  in Figure 3A, it can go much higher if the charged inductor is simply left open with no alternate path provided for discharge current as shown in Figure 3B. Thus, you could be fooled into thinking that the growing negative voltage spike across the inductor in Figure 3B must spike a higher transient current greater than  $i_o=V_s/R$ , since it decays exponentially according to  $i(t)=V/R*e^{-tR/L}$ . But keep in mind that current in an inductor can’t spike. Rather, the inductor will increase its own resistance as required to oppose a change in its current with the higher reverse voltage and will change gradually. Realize also that in reality, the “R” of our simplified circuit formulae represents the total resistance of our circuit--the resistor shown plus the wire resistance, plus the coil resistance. So while  $i$  does decay according to  $i(t)=V/R* e^{-tR/L}$ , the increasing reverse  $V_L$  for a charged inductor when switched open is accompanied by rising  $R_L$  to keep  $i(t)$  constrained to a limit below  $i_o=V_s/R$ .

One method to curb destructive switching transient voltage is illustrated in Figure 3C. Here we have placed a diode in reverse across the inductive load so that when the switch is opened, the reverse voltage developed across the inductor is clamped to the forward voltage drop of the diode and the charged inductor energy is safely shunted through the diode, where it is instead dissipated via heat through the resistance of the coil-diode circuit.

**3C COMMON RL DISCHARGE CYCLE WITH ADDED PROTECTION**

**THE REVERSE EMF  $V_L$  THAT RESULTS WHEN NORMAL CURRENT FLOW IS INTERRUPTED IN THE INDUCTOR IS CLAMPED TO A SAFE VOLTAGE LEVEL EQUAL TO THE FORWARD VOLTAGE DROP OF THE DIODE, PREVENTING IT FROM BEING DISTRIBUTED ACROSS THE WIRING BETWEEN THE SWITCH AND LOAD WHERE IT COULD RAISE EMISSIONS, DAMAGE THE SWITCH, AND WREAK HAVOC IN ADJACENT WIRING AND COMPONENTS.**

Just as in Figure 3B, upon discharging, the inductor has initial current  $i_0 = V_s/R$  through it which decays gradually according to  $i = V_s/R * (e^{-Rt/L})$  when the switch is opened. However, the  $R$  in this expression is not the physical resistor shown in the circuit. It is the  $R$  contributed by the added diode, the coil itself, and the wiring to the diode.

The current path from the battery was broken, but an alternate path for discharge current has been added by placing a diode near the load. The inductor resists an instant change in its current from  $i = V_s/R$  by instantly imposing a rapid reverse voltage across itself that reinforces current flow in the inductor in the same direction as before the switch opened. The transient current will complete its circuit path through the local diode, constraining the magnitude of the negative  $V_L$  voltage transient and preventing it from being conducted along the wiring between the load and switch.

Upon discharging, the voltage across the inductor instantly reverses to  $V_L = -L * di/dt = -V * e^{-t*L/R}$ , but the magnitude of  $V$  is clamped to the forward voltage drop of the added diode. The stored energy  $W = 0.5 * L * i_0^2$  in the inductor is dissipated as heat in the diode and diode-coil circuit resistance.

TIP: The reverse shunt diode you select should have a forward current rating greater than  $V_s/R$  and a reverse blocking voltage rating at least twice the operating voltage. Make sure the power dissipated in the diode  $P = V_f * i_0$  does not exceed the diode's rated power dissipation.

To review, we've shown that reverse switching transient voltages develop across an inductive load because the current through the inductance cannot change magnitude or direction instantly when the normal current path through it has been broken. The transient that results is a by-product of retained energy in the inductive load as its current is adjusted lower and this energy must be dissipated somewhere (the inductor magnetic energy =  $\frac{1}{2} * L * i^2$ ). By placing a diode right at the load in reverse of normal current through the load, the diode will forward bias with the reverse voltage and clamp this transient voltage to a safe level near the forward voltage drop of the diode ( $\sim 1V$ ).

The added protection diode illustrated in Figure 3C is sometimes referred to as a freewheeling, flyback, or flywheel diode. Its sole purpose is to quickly squelch the high reverse voltage transient that develops across the inductive load when current through it is switched off. We recommend adding this diode at the load even though our own solid-state switching devices usually include some similar protection built-in. But proximity to the load is important, and this prevents the transient from being distributed along the wiring between the switch and load. To place it anywhere else would not be as effective and would allow the transient energy to move along the wiring back to the switch, radiating or inductively coupling noise into adjacent wiring and other devices, and possibly damaging the switch.

DC solid-state switches often include some built-in protection such as source to drain diodes and/or parallel transient voltage suppressors. This is helpful, but all transient protection is ultimately degenerative to the protection device. That is, TVS diodes degrade slightly each time they clamp and can ultimately fail short, silicon based rectifiers can erode and leak over time, and solid-state mosfets or transistors can develop drain-to-source leakage with repeated reverse voltage stress over time. Keep in mind that the wiring between the switch and load is also increasingly inductive over long distances, which will further impede the ability of any integrated switch protection in the switch itself to adequately squelch the transient switching voltages from the load quickly and efficiently if they are relied on to provide necessary load protection. Take care to avoid subjecting a switching system to the extra stress of high transient voltages that can otherwise be avoided, and do not allow your application wiring to carry transient energy over long distances. This is why it is best to build this protection local to the load being switched.

**What About AC Inductive Load Switching?**

Adding a diode local to the inductive load as illustrated in Figure 3C works great for switching DC inductive loads, but this is not effective for AC switched inductive loads, because it only works for a reverse voltage in one direction. For AC inductive loads, we need to be able to shunt the reverse transient voltage  $V_L$  of the inductor in both directions, and we can do this by simply replacing the diode of Figure 3C with a bipolar voltage clamping device like a Metal Oxide Varistor (MOV) or Transient Voltage Suppressor (TVS). For AC applications, we must make this selection a little more carefully by choosing a MOV or TVS with a clamped voltage rating greater than our peak application voltage, and a current rating greater than our application current by an additional amount that supports additional peak current contributed by a MOV/TVS clamp voltage above our normal application voltage.

**Conclusion**

The on/off control of motor windings, solenoids, relay coils, and even the wiring between devices make inductive switching transients ever present. You must take steps to curb the destructive transients produced when switching inductive loads to not only protect your equipment and extend its life, but to lower coupled noise and emissions, and even help protect personnel. Be leery of any load switching product that does not address “Best-Practice” recommendations in this regard.

<i>Bruce Cyburt, Senior Design Engineer, Acromag, Inc., January 4, 2017</i>
---

**About Acromag**

Acromag manufactures signal conditioning and fieldbus I/O solutions. New distributed I/O modules support Ethernet IP, Profinet, Profibus, both Modbus TCP/IP and RTU. Process instruments include signal transmitter/converters, loop isolators, signal splitters, alarm trips, and computation modules. BusWorks® remote I/O modules for Ethernet IP, Profinet, Profibus and Modbus interface analog and discrete I/O signals.

Acromag I/O is ideal for a broad range of monitoring and control operations where controllers communicate with instrumentation on the plant floor or in the field. Signal conditioner products include process transmitters, 4-20mA signal isolators, limit alarms, panel meters, and math computation modules. These signal conditioning products isolate, amplify, filter, condition, and convert measured signals from sensors and other instruments. The enhanced signal is ready for interfacing to your PLC, DCS, display, recorder, or other process control instrumentation.

Acromag products are built to the highest quality standards. Manufacturing is located in Wixom Michigan and is ISO9001 and AS9100 certified. Acromag products are designed to be rugged. Many have CE, UL, cUL, ATEX certification and are approved for Class 1 Div 2 Zone 2 operation and temperatures from -40 to 80°C.

For more information about Acromag products, call the Inside Sales Department at (248) 295-0880, FAX (248) 624-9234. E-mail [sales@acromag.com](mailto:sales@acromag.com) or write Acromag at 30765 South Wixom Road, Wixom, MI 48393-7037 USA. The website is [www.acromag.com](http://www.acromag.com).