

APPLICATIONS

Mazda 6 2003-2005

KIT FEATURES

- Double DIN radio provision
- ISO DIN radio provision with pocket
- *Painted silver*



KIT COMPONENTS

- A) Radio/Climate control housing
- B) Radio brackets
- C) Pocket
- D) (4) #8 x 3/8" Phillips screws
- E) (6) Plastic panel clips
- F) Harness
- G) (2) #8 x 1" Phillips screws

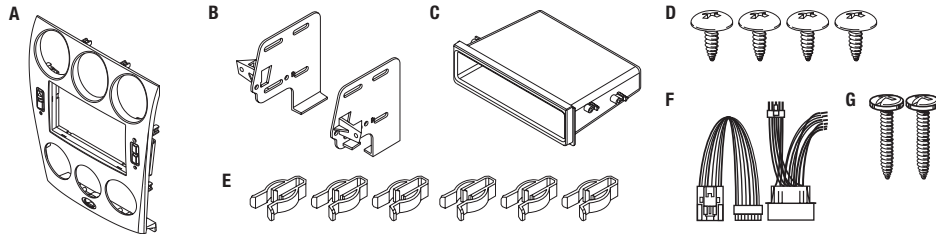

Wiring Harness: • Included with kit

Antenna Adapter: • Not required

Table of Contents

Dash Disassembly

- Mazda 6 2003-2005 2-4

Kit Assembly

- Electronic climate control 5
- Manual climate control 6
- Felt tape application 7
- ISO DIN radio provision with pocket 8
- Double DIN radio provision 8
- Display customization 9
- Final wiring and assembly 10-11

TOOLS REQUIRED

- Small flat blade screwdriver
- Phillips screwdriver
- Socket wrench

CAUTION: All accessories, switches, and especially air bag indicator lights must be plugged in before reconnecting the battery or cycling the ignition.

NOTE: Refer to the instructions included with the aftermarket radio.

Dash Disassembly

Electronic Climate Control

1. Unscrew the shift knob counter clockwise to remove. (Figure A)
2. Unclip and remove the cup holder/ parking brake cover and shifter cover as one radio. (Figure B)
3. Remove (2) Phillips screws from the bottom of the radio/climate control panel. (Figure C)
4. Open glove box, squeeze sides together and let open fully then remove (1) 10 mm bolt from the side of the radio bracket. (Figure D)

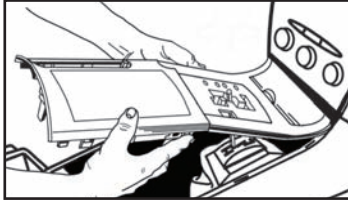

(Figure B)

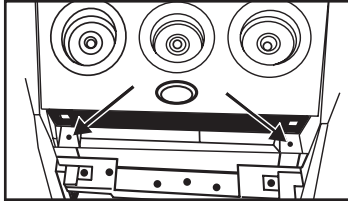

(Figure C)

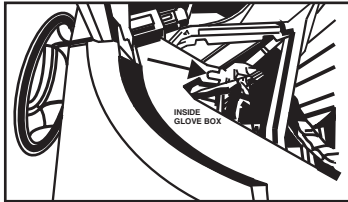

(Figure D)

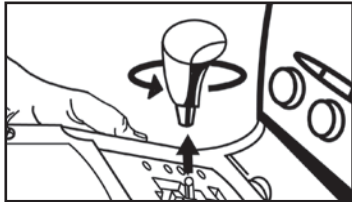

(Figure A)

5. Unsnap and remove radio/climate control panel including climate control vents at the top. (Figure E)
6. Remove (4) Phillips screws securing vents to radio/climate control panel to remove. (Figure F)
7. Remove (8) Phillips screws securing the electronic climate control to the radio/climate control panel to remove. (Figure F)
8. Remove (4) Phillips screws securing the radio display harness bracket to the radio chassis then unclip and remove the radio display harness. (Figure H)

Continue to kit assembly

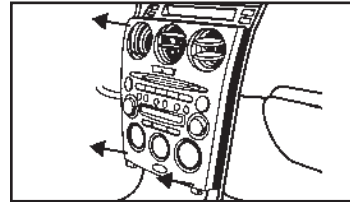

(Figure E)

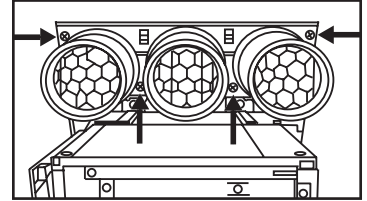

(Figure F)

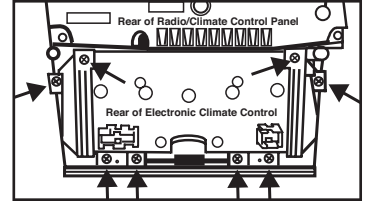

(Figure G)

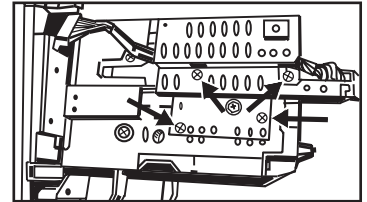

(Figure H)

Dash Disassembly

Manual Climate Control

1. Unscrew the shift knob counter clockwise to remove. (Figure A)
2. Unclip and remove the cup holder/parking brake cover and shifter cover as one radio. (Figure B)
3. Remove (2) Phillips screws from the bottom of the radio/climate control panel. (Figure C)
4. Pull the climate control knobs off and remove (2) Phillips screws from behind knobs. (Figure D)

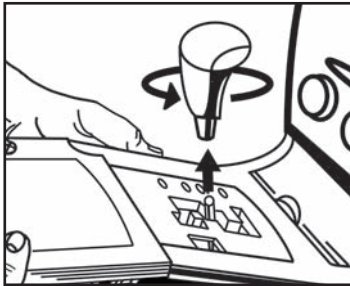

(Figure A)

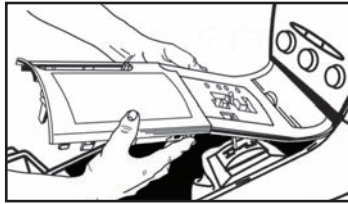

(Figure B)

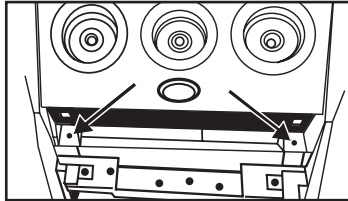

(Figure C)

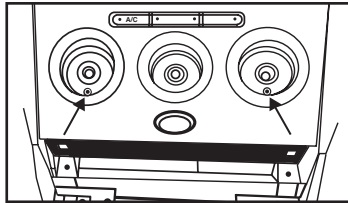

(Figure D)

5. Open glove box, squeeze sides together and let open fully then remove (1) 10 mm bolt from the side of the radio bracket. (Figure E)
6. Unsnap and remove radio/climate control panel including climate control vents at the top. (Figure F)
7. Remove (4) Phillips screws securing vents to radio/climate control panel to remove. (Figure G)

Continue on next page

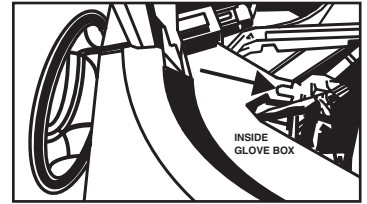

(Figure E)

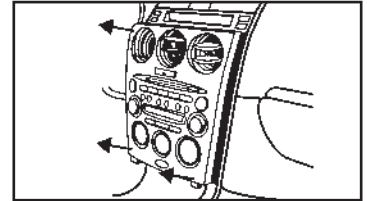

(Figure F)

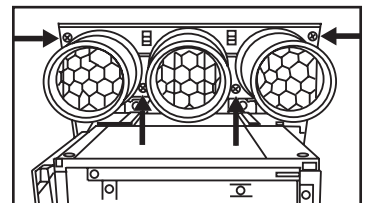

(Figure G)

Dash Disassembly

Manual Climate Control (continued)

- Remove the (2) small Phillips screws securing the light bulb boards on each side of the backlight dispersion bar.
Note: Notice how they are positioned in the backlight dispersion bar as they will be placed in the FK-996 the same way. (Figure H)
- Remove (4) Phillips screws securing backlight dispersion bar and knob trim bezels. (Figure I)

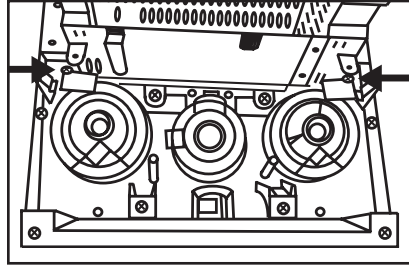

(Figure H)

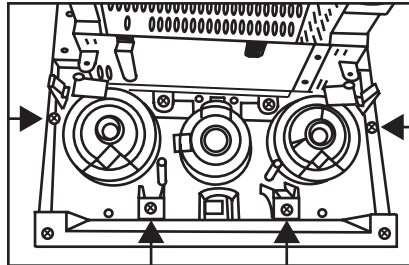

(Figure I)

- Push the bottom edges of the knob trim bezels from the front side to the back and slide both pieces out as one radio. (Figure J)
- Remove (4) Phillips screws securing the radio display harness bracket to the radio chassis then unclip and remove the radio display harness. (Figure K)

Continue to kit assembly

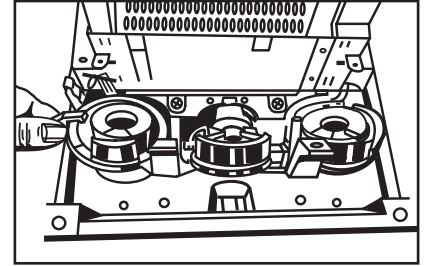

(Figure J)

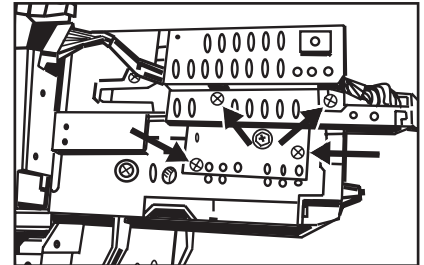

(Figure K)

Kit Assembly

Electronic Climate Control

1. Clip the climate control knob outer trim ring panel into the housing.
(Figure A)
2. Align the screw holes in the climate control and the radio housing panel then push the climate control onto the radio housing panel.
(Figure B)

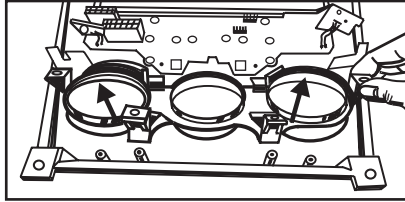

(Figure A)

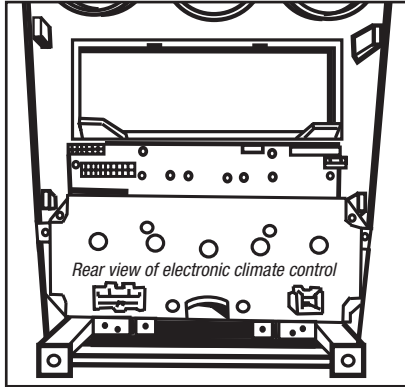

(Figure B)

3. Secure the climate control with the factory hardware removed in step 7 of the dash disassembly for electronic climate control cars.
4. Unclip and remove the small oval cover plate at the bottom center of the factory radio and insert into the radio housing.
(Figure C)

Note: The light bulb boards will not be used with auto climate control vehicles disregard these bulbs.

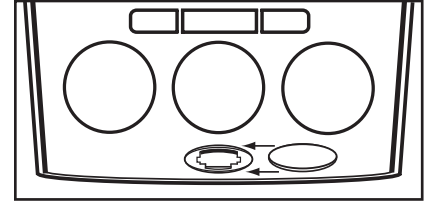

(Figure C)

Kit Assembly

Manual Climate Control:

1. Put the climate control knob outer trim panel and the backlight dispersion bar together and clip into the radio housing panel as one radio.

Note: You may have to push down slightly on the middle of the radio to ease in positioning it into the kit. (Figures A, B, C)

2. Secure the radio with the factory hardware removed in step 9 of the manual climate control dash disassembly.

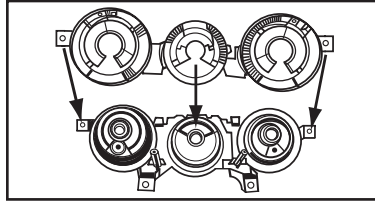

(Figure A)

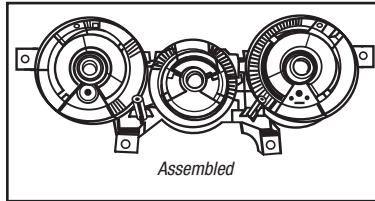

(Figure B)

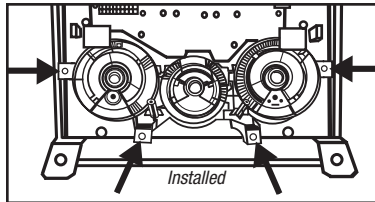

(Figure C)

3. Secure the light bulb boards on each side of the backlight dispersion bar using the factory hardware removed in step 8 in manual climate control dash disassembly. (Figure D)
4. Unclip and remove the small oval cover plate at the bottom center of the factory radio and insert into the radio housing. (Figure E)

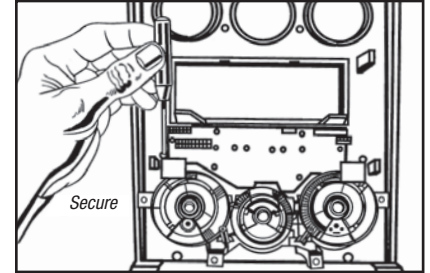

(Figure D)

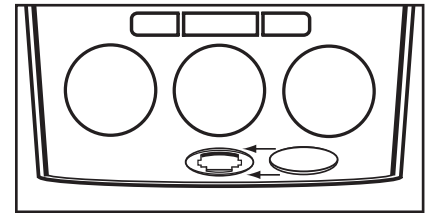

(Figure E)

Kit Assembly

Felt Tape Application

Note: Due to differences in factory tolerances you may need to apply the provided felt tape to the edge of the radio housing to relieve backlight bleed through.

1. Looking at edge of radio housing apply felt tape to inner edge (toward back of kit). If it is positioned too closely to the outer edge you may be able to see it once it is in the dash. (Figure A)
2. Attach the included six panel clips to the radio housing.

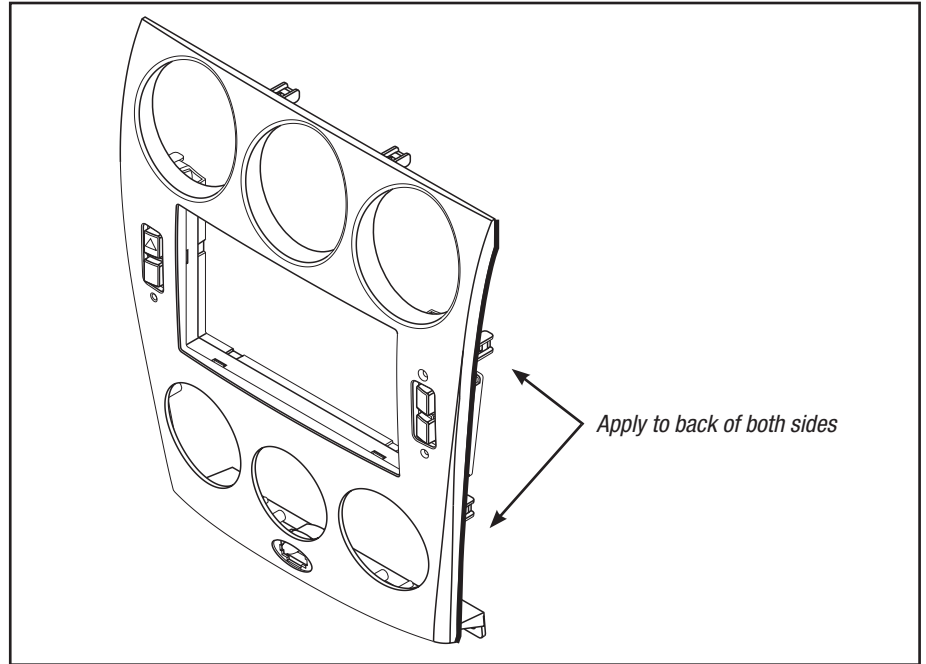

(Figure A)

Kit Assembly

ISO DIN radio provision with pocket

1. Mount the pocket to the radio brackets with the (4) #8 x 3/8" Phillips screws supplied. (Figure A)
2. Slide the radio into the radio brackets/pocket assembly and secure with the screws supplied with the radio. (Figure B)
3. Locate the factory wiring harness and antenna plug in the dash.
4. Mount the new radio assembly into the dash and reassemble dash in reverse order of disassembly.
5. There are no existing holes for the radio mounting. New holes will be made using the included one inch screws. The radio brackets will rest on a shelf in the sub-dash. Be sure the radio is level and centered while mounting the radio/ bracket assembly into the dash opening.

Continue on next page

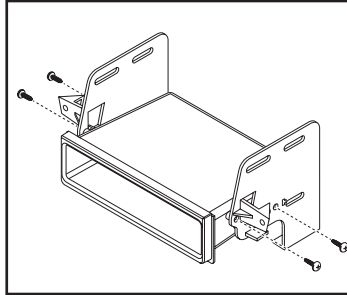

(Figure A)

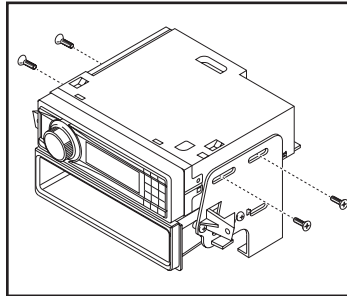

(Figure B)

Double DIN radio provision

1. Attach the double DIN radio to the radio brackets using the screws supplied with the radio. (Figure A)
2. Locate the factory wiring harness and antenna plug in the dash.
3. Mount the new radio assembly into the dash and reassemble dash in reverse order of disassembly.
4. There are no existing holes for the radio mounting. New holes will be made using the included one inch screws. The radio brackets will rest on a shelf in the sub-dash. Be sure the radio is level and centered while mounting the radio/ bracket assembly into the dash opening.

Continue on next page

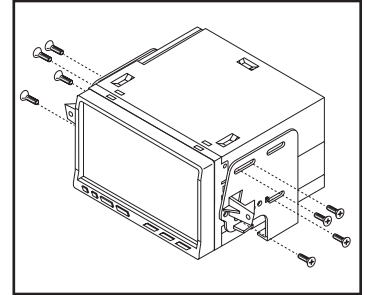

(Figure A)

Kit Assembly

Start the car and test all the climate control functions.

Note: The air recirculation light will be on at initial startup and will not go out until using the climate controls for the first time.

Display Customization:

1. Press and hold the **Clock** button in the factory display until “**Set Text**” is displayed then release button. Settings will begin with the first character location. Use the **Set** button to select the desired character then press the **AMB** button to select the next character location. There are 10 available character locations.
2. Once the desired text is entered if you do not touch any buttons for 10-seconds the display will read “**Saved Text**” and your text will be saved.

3. To set the clock press and hold the **Clock** button until “**Hr. Adjust**” is displayed then use the **Set** button to select the desired hour.
4. Press the **Clock** button again and the display will read “**Min. Adjust**” then use the **Set** button to select the desired minutes.

Note: If equipped with a dimmer button it will still function as normal.

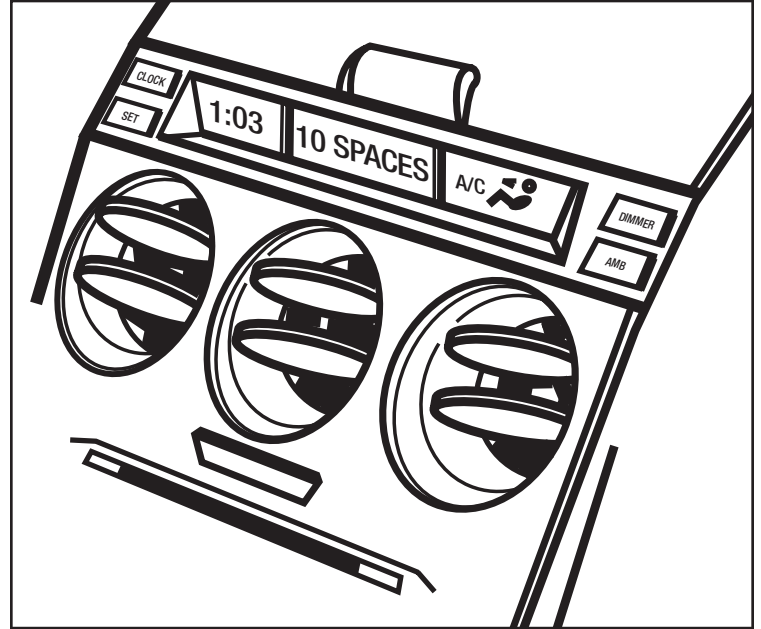

Final Wiring and Assembly

Connections to be made to the aftermarket radio:

- Connect the **Yellow** wire to the 12-volt battery/memory wire.
- Connect the **Red** wire to the accessory/ignition wire.
- Connect the **Orange** wire to the illumination wire. *If the aftermarket radio has no illumination wire, cap off the **Orange** wire.*
- Cap off and disregard the **Orange/White** wire, it will not be used in this application.
- Connect the **Black** wire to the ground wire.
- Connect the **Blue** wire to the antenna turn on wire.
- Connect the **Blue/White** wire to the amp turn-on wire, if the vehicle also amplified.
- Connect the **White** wire to the left front positive speaker output.
- Connect the **White/Black** wire to the left front negative speaker output.
- Connect the **Gray** wire to the right front positive speaker output.
- Connect the **Gray/Black** wire to the right front negative speaker output.
- Connect the **Green** wire to the radio's left rear positive speaker output.

- Connect the **Green/Black** wire to the radio's left rear negative speaker output.
- Connect the **Purple** wire to the radio's right rear positive speaker output.
- Connect the **Purple/Black** wire to the radio's right rear negative speaker output.

Connections to be made to the kit:

1. Plug the 8-way connector supplied into Location 1, on the back of the radio housing (see diagram, on right).
2. Plug the 16-way connector, that was removed from the factory radio, into Location 2 (see diagram, on right).
3. **For manual climate control vehicles only:** Plug the 16-way connector supplied into Location 3 (see diagram, on right).
***Note:** Automatic climate control vehicles will not use this harness.*
4. Reconnect the negative battery terminal and test the radio for proper operation.
5. Reassemble the radio and dash assemblies in reverse order of disassembly.

