



INSTALLATION INSTRUCTIONS FOR PART 99-2011

APPLICATIONS

See application list inside

GM/Suzuki multi-kit 1990 - up 99-2011

KIT FEATURES

- Double DIN radio provision
- ISO mount unit provision with pocket



KIT COMPONENTS

- A) Double DIN Trim Plate • B) Double DIN Brackets • C) Spacers • D) (4) Carriage Bolts
- E) (4) Kep Nuts • F) (3) Screws w/(3) Speed Clips • G) (4) #8 x 3/8" Phillips Screws • H) Pocket

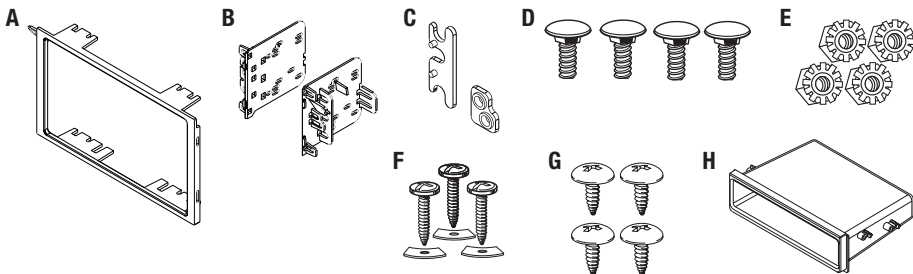

WIRING & ANTENNA CONNECTIONS (Sold Separately)

Wiring Harness: Please see www.metraonline.com for specific interface applications

- Antenna Adapter: • 40-GM10 GM Antenna Adapter 1988-up
• 40-CR10 Chrysler antenna adapter 2002-up

TOOLS REQUIRED

Cutting Tool • Phillips Screwdriver • Socket Set

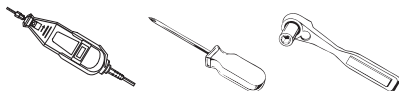



99-2011

Applications

Buick

Century	1997-2005
Le Sabre	1995-2005
Park Avenue	1995-2005
Rainier	2004-2007
Regal	1995-2004
Rendezvous	2002-2007
Riviera	1996-1999
Roadmaster	1995-1996
Skylark	1996-1998

Cadillac

Escalade/EXT	2003-2006
Fleetwood/	
Brougham	1990-1996
Eldorado	1992-1995
Seville	1992-1995

Chevrolet

Avalanche	2003-2006
Blazer	2002-2005
Cavalier	2000-2005
Colorado	2004-up
Express Van (full size)	2001-2007
Impala	2000-2005
Malibu	2001-2003
Malibu Classic	2004
Metro (Geo included)	1995-2001
Monte Carlo	2000-2005
SSR	2003-2006
S-10 Pickup with	
DDIN Radio	2002-2004

Chevrolet (cont.)

Silverado	2003-2007
Suburban	2003-2006
Tahoe	2003-2006
Tracker	1992-2004
Trailblazer	2002-2009
Venture	2000-2005

GMC

Canyon	2004-up
Envoy	2002-2009
Savanna	2001-2007
Sierra	2003-2007
Sonoma	2002-2004
Yukon/Denali/XL	2003-2006

Honda

Passport	1998-2002
----------	-----------

Hummer

H2	2003-2007
----	-----------

Isuzu

Ascender	2003-2009
Amigo	1998-2000
I-290/I370	2007-2008
I-280/I350	2006
Rodeo	1998-2004
Rodeo Sport	2001-2003

Oldsmobile

Achieva	1996-1998
---------	-----------

Oldsmobile (cont.)

Alero	1999-2004
Aurora	1995-2003
Bravada	1998-2001
Bravada	2002-2004
Cutlass	1997-1999
Cutlass Supreme	1995-1997
Eighty-Eight	1994-1999
Intrigue	1998-2002
LSS	1996-1999
Ninety-Eight	1994-1996
Regency	1997-1998
Silhouette	2000-2004

Pontiac

Aztec	2001-2005
Bonneville	2000-2005
Grand Am	2001-2005
Montana	2000-2005
Sunfire	2000-2005

Suzuki

Aerio	2002
Esteem	1995-2003
Sidekick	1992-1998
Swift	1995-2001
Vitara	1999-2005
Grand Vitara	1999-2002
XL-7	2001-2002

Toyota

Matrix	2003-2004
--------	-----------



Dash Disassembly 99-2011

Buick Century 1997-2005 **Buick Regal 1995-2004**

1. Remove the plastic trim piece to the left of the glove box and (1) Phillips screw exposed.
2. Unsnap the top edge of the knee bolster panel.
3. Remove (1) Phillips screw from the panel.
4. Remove the ashtray cluster and (2) Phillips screws from each side.
5. Unclip the entire dash trim bezel and remove.
6. Open doors and unsnap end caps from each side of dash.
7. Unsnap and remove radio/instrument cluster panel.
8. Remove (3) screws in order to remove radio.

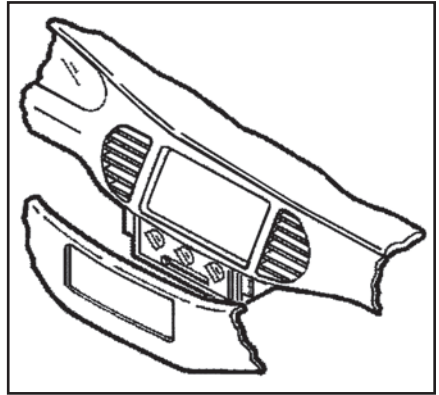

Continue to kit assembly



Dash Disassembly 99-2011

Buick Le Sabre 1995-1999 **Buick Park Avenue 1995-1999**

1. Unsnap the climate control trim panel (from door to door) and remove (4) Phillips screws exposed.
2. Pop out the a/c vents and remove (1) Phillips screw exposed in each vent cavity.
3. Unclip the radio trim bezel and remove.
4. Remove the screws securing the factory head unit and disconnect the wiring.

Continue to kit assembly

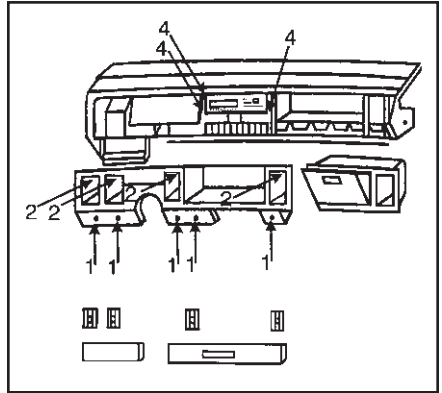

Buick Le Sabre 2000-2005 **Buick Park Avenue 2000-2005**

1. Open drivers door and unsnap and remove dash end cap.
2. Unsnap and remove trim along center of dash. (One piece on right and one on left of wheel)
3. Unsnap and remove radio/instrument bezel.
4. Remove (2) screws in order to remove radio.

Continue to kit assembly

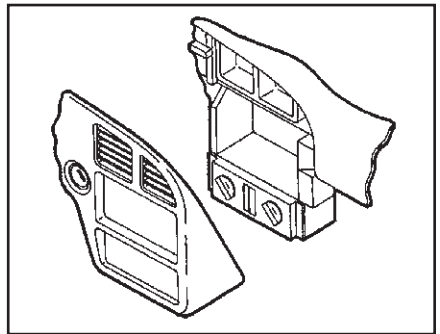



Dash Disassembly 99-2011

Buick Rendezvous 2002-2007

1. Open center console and remove 2 screws at front of console opening. (Figure A)
2. Remove liners from cup holders and storage pocket next to cup holders, then remove screws. Unsnap and remove panel. (Figure B)
3. Remove (2) screws from bottom of radio/climate control bezel, unclip and remove. (Figure C)
4. Remove (3) 9/32" hex head screws to remove radio. (Figure D)

Continue to kit assembly

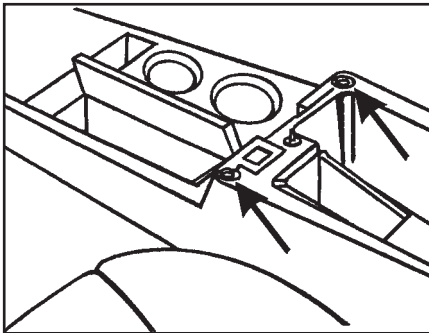

(Figure A)

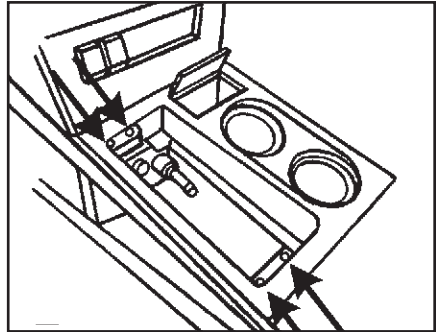

(Figure B)

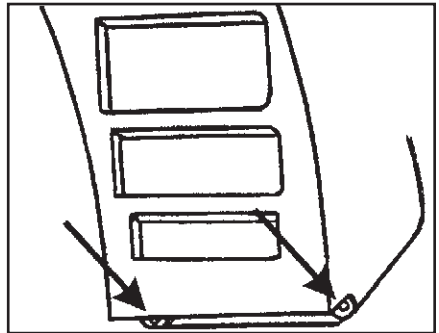

(Figure C)

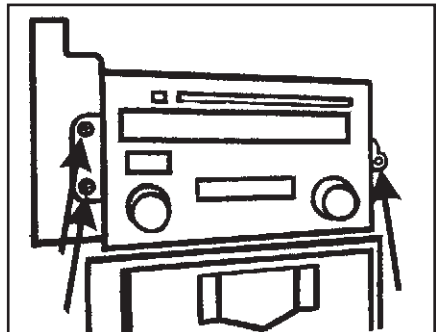

(Figure D)



Dash Disassembly 99-2011

Buick Riviera 1996-1999

1. Unsnap left side panel exposing (1) Phillips screw to remove.
2. Remove (1) Phillips screw and unsnap right side panel to expose (1) Phillips screw beneath panel and remove.
3. Unsnap underside of overhanging dash to unsnap (6) plastic rivets and remove panel.
4. Remove (5) hex head screws now exposed under overhang.
5. Unsnap bottom edge of trim bezel, then while holding overhang up, unsnap and remove trim bezel by removing any necessary harnesses.
6. Remove (3) Phillips screw to remove climate control.
7. Remove (2) Phillips screws to remove rear support and (3) 9/32" hex head screws to remove radio.

Continue to kit assembly

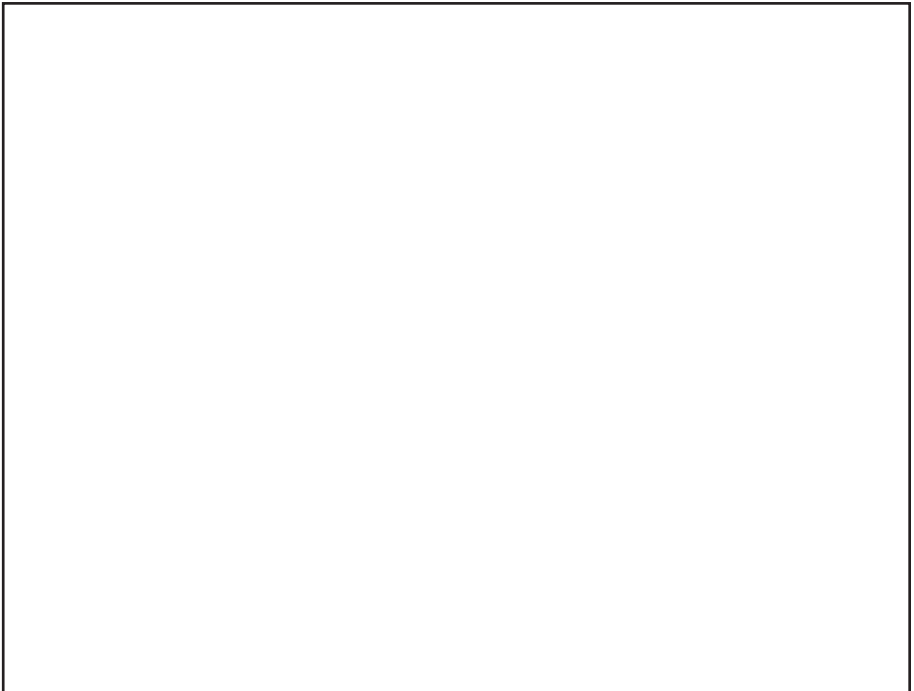



Dash Disassembly 99-2011

Buick Roadmaster 1995-1996

1. Unclip dash panel sides and remove.
2. Unclip panel below steering column and remove.
3. Remove (2) 7 mm screws above instrument cluster.
4. Set parking brake, turn car on, and move shifter to the lowest gear. Tilt steering wheel down then unsnap entire instrument cluster/radio panel and remove.
5. Remove (3) 7 mm screws to remove radio.

Continue to kit assembly

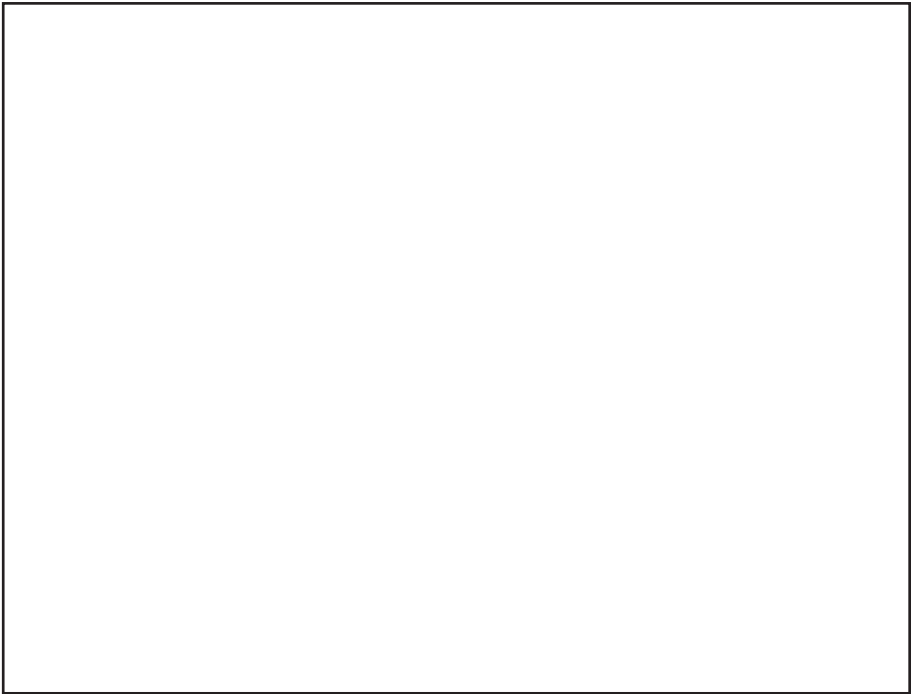



Dash Disassembly 99-2011

Buick Skylark 1996-1998

1. Remove (6) 9/32" screws inside glove box.
2. Under glove box and drivers knee bolster, remove (2) plastic panels by turning (2) 1/4 turn fasteners per side.
3. Remove (4) 9/32" screws revealed. (2 per side).
4. Unsnap panel from driver's side to passenger's side.
5. Remove (3) 9/32" screws to remove radio.

Continue to kit assembly

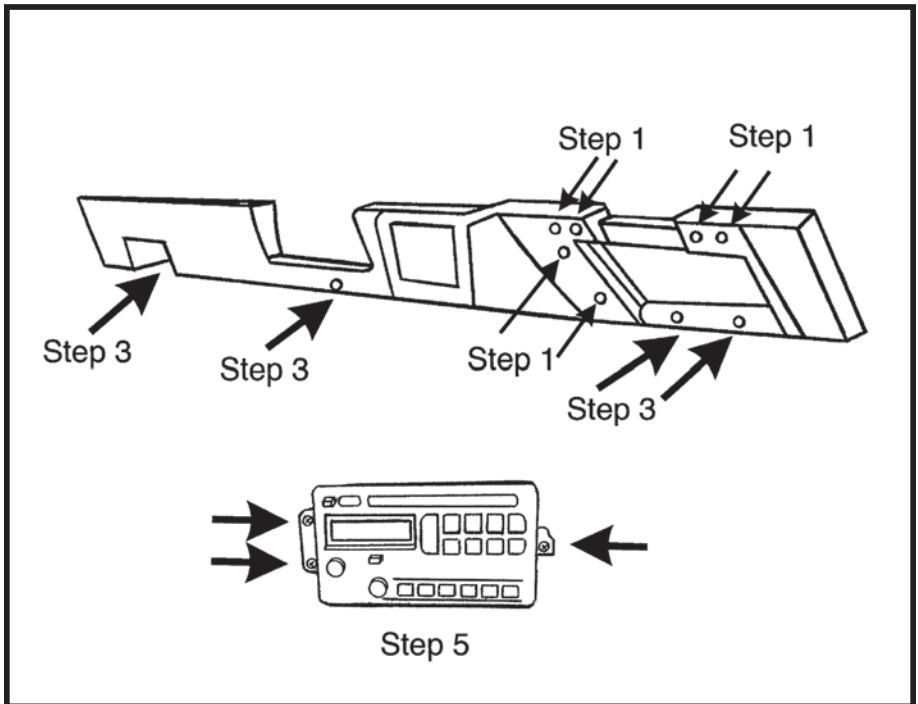



Dash Disassembly 99-2011

Cadillac Escalade/EXT 2003-2006
Chevrolet Avalanche 2003-2006
Chevrolet Silverado 2003-2007
Chevrolet Suburban 2003-2006
Chevrolet Tahoe 2003-2006
GMC Sierra 2003-2007
GMC Yukon/Denali/XL 2003-2006

1. Unsnap and remove dash bezel.
2. Remove (3) 9/32" screws and remove radio.

Continue to kit assembly

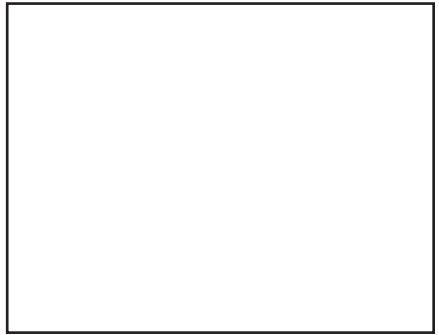



Dash Disassembly 99-2011

Cadillac Fleetwood/Fleetwood Brougham 1990-1996

1. Carefully unsnap trim panel above a/c controls. (Figure A)
2. Remove (2) 7 mm screws at the top of the radio/air conditioning bezel, then unclip panel and remove. (Figure B and C)
3. Remove (4) 7 mm screws that hold the radio in, slide radio out, unplug the radio harnesses and remove radio. (Figure D)

Continue to radio bracket disassembly

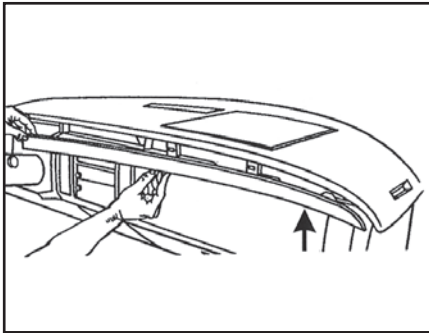

(Figure A)

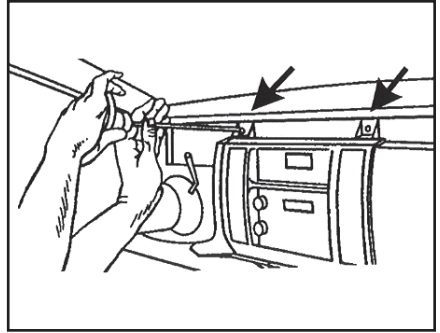

(Figure B)

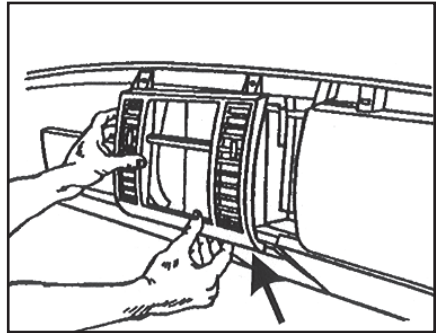

(Figure C)

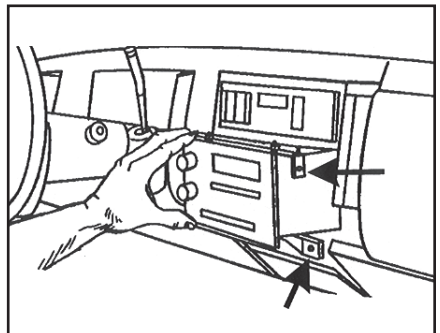

(Figure D)



Radio Bracket Disassembly 99-2011

Cadillac Fleetwood/Fleetwood Brougham 1990-1996

1. Remove (4) 10 mm nuts, (2) on top of the radio and (2) on the bottom of the radio, that hold the factory mounting brackets on. Save brackets and nuts for kit assembly.

Continue to kit assembly

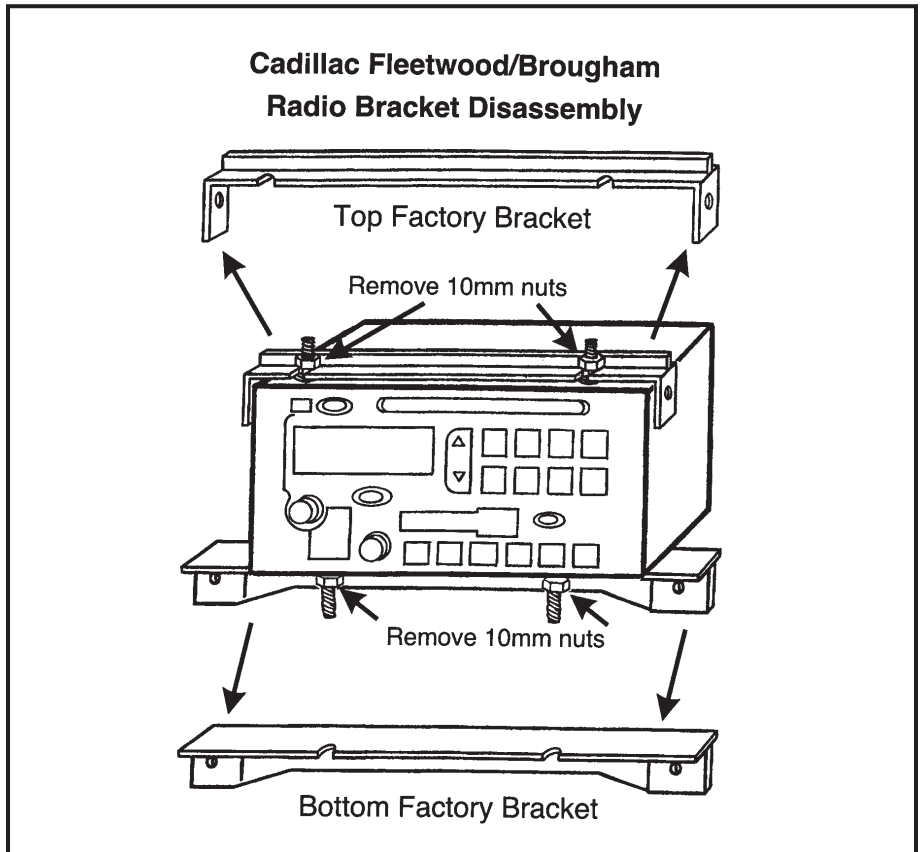



Dash Disassembly 99-2011

Cadillac Eldorado 1992-1995 Cadillac Seville 1992-1995

1. Using a panel removal tool, pry out on the radio trim ring and remove. Use extreme care when removing).
2. Gently pry up on the ashtray/gear shifter trim bezel and remove. **(CAUTION: Some models are equipped with bezels made of real wood).**
3. Remove (2) nuts securing the bottom of the factory head unit and disconnect the wiring.)

Continue to kit assembly

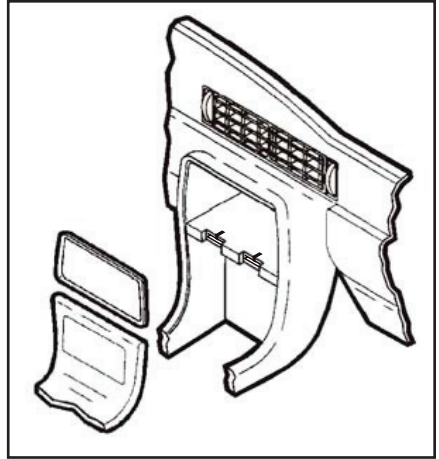



Dash Disassembly 99-2011

Chevrolet Blazer 2002-2005 **Chevrolet S-10 2002-2004** *(With Double DIN radio)* **GMC Sonoma 2002-2004** **Oldsmobile Bravada 1998-2001**

1. Remove (2) 9/32" hex-head screws from the knee bolster panel.
2. Pull down on the panel and remove the 9/32" hex-head screws exposed on the bottom of the dash trim bezel.
3. Remove (1) Phillips screw above the instrument cluster.
4. Unclip the dash trim bezel and remove.
5. Remove (2) 9/32" hex-head screws securing the factory head unit and disconnect the wiring.

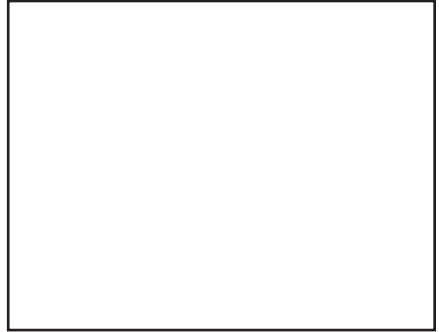

Continue to kit assembly



Dash Disassembly 99-2011

Chevrolet Cavalier 2000-2005

1. Open drivers door and remove fuse panel on end of dash.
2. Open passenger door and remove panel on end of dash.
3. Remove (1) Phillips screw from each side exposed.
4. Remove (3) screws from top of glove box liner.
5. Remove (2) screws from the top-left corner of the glove box cavity.
6. Remove (1) Phillips screw from the defroster duct.
7. Remove the ductwork and (1) Phillips screw exposed.
8. Remove the dash pad and (3) Phillips screws exposed at the top of the radio trim bezel.

Continue to kit assembly





Dash Disassembly 99-2011

Chevrolet Colorado 2004-up GMC Canyon 2004-up Isuzu I-290/I-370 2007-2008 Isuzu I-280/I-350 2006

1. Unsnap and remove the entire panel surrounding the radio and A/C controls. (Figure A)
2. Remove (3) 9/32" screws securing the radio to remove. (Figure B)

Continue to kit assembly

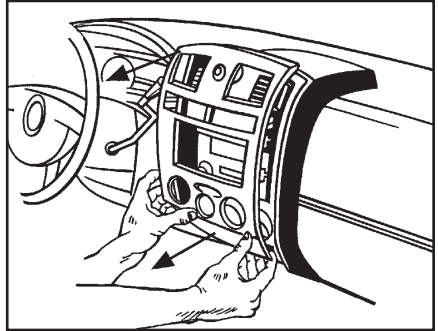

(Figure A)

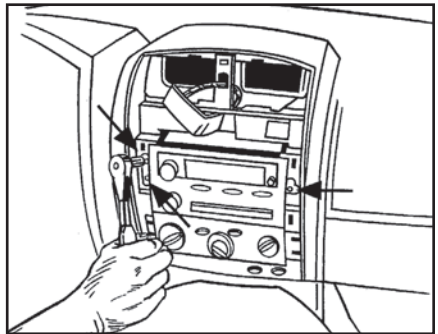

(Figure B)



Dash Disassembly 99-2011

Chevrolet Express Van 2001-2002 GMC Savanna 2001-2002

1. Unsnap and remove small trim panel below steering column. (Figure A)
2. Unsnap radio/climate/instrument panel. (Figure B)
3. Move shift lever to first gear position.
4. Rotate panel counterclockwise to lift over steering column and remove.
5. Remove (3) 9/32" hex head screws to remove radio. (Figure C)

Continue to kit assembly

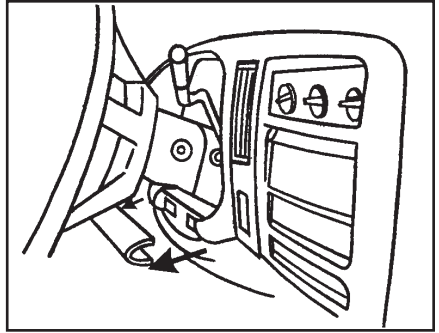

(Figure A)

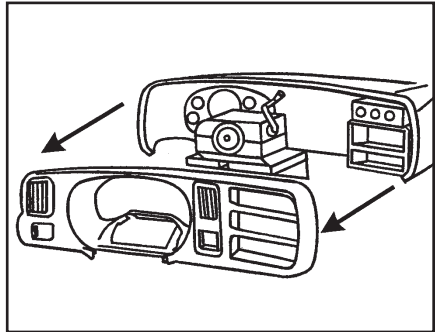

(Figure B)

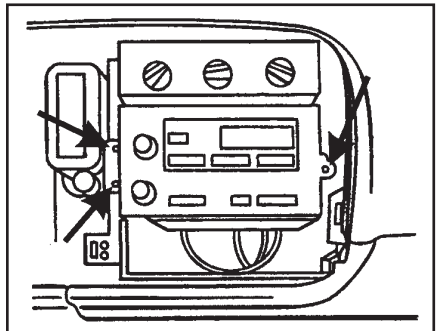

(Figure C)



Dash Disassembly 99-2011

Chevrolet Express Van 2003-2007 GMC Savanna 2003-2007

1. Remove (2) 10 mm bolts from below knee bolster under steering column and remove panel. (Figure A)
2. Remove (2) 10 mm bolts from panel below passenger dash airbag and remove panel. (Figure B)
3. Remove (2) 10 mm nuts from inside center pocket between power outlets. (Figure C)
4. Unsnap and remove radio and instrument cluster panel. *(May not be necessary to completely remove radio and instrument cluster panel to access radio.)*
5. Remove (3) 9/32" bolts to remove radio. (Figure D)

Continue to kit assembly

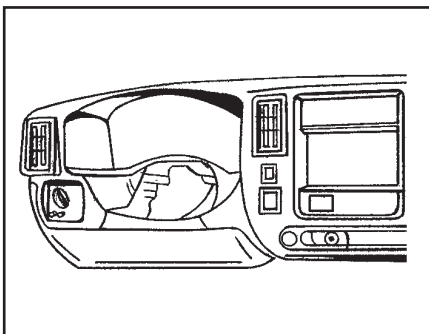

(Figure A)

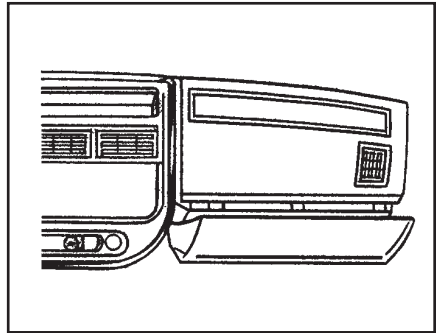

(Figure B)

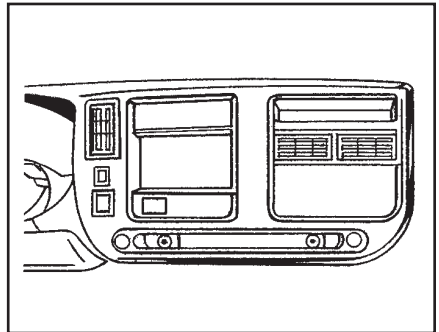

(Figure C)

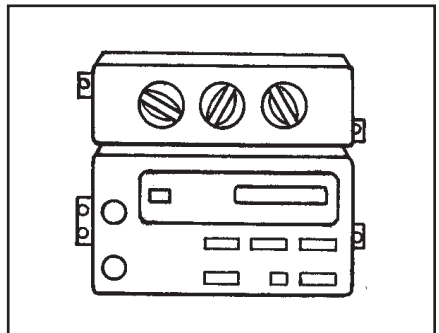

(Figure D)



Dash Disassembly 99-2011

Chevrolet Impala 2000-2005

1. Unclip each side of the dash trim bezel (fuse access) and remove (1) Phillips screw exposed on each side.
2. Remove (2) Phillips screws under the instrument cluster.
3. Unclip the trim panel above the pedals. (It is not necessary to remove the panel it can be left hanging).
4. Remove (2) Phillips screws from the knee panel.
5. Unclip the knee panel and remove (1) phillips screw exposed on the right side of the steering column.
6. Unclip and remove the entire dash trim bezel.

Continue to kit assembly

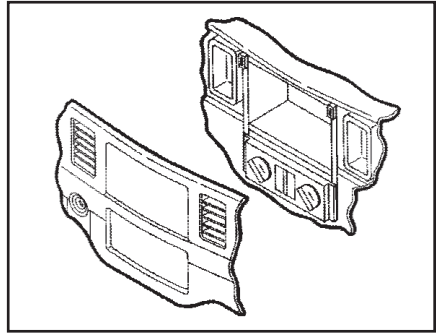

Chevrolet Malibu 2001-2003 Chevrolet Malibu Classic 2004

1. Unsnap and remove radio bezel.
2. Remove (3) bolts and remove radio.

Continue to kit assembly





Dash Disassembly 99-2011

Chevrolet Metro 1995-2001 Suzuki Swift 1995-2001

1. Remove the ashtray and (2) Phillips screws exposed.
2. Remove (2) Phillips screws above the radio opening.
3. Unclip the radio trim bezel and disconnect the cigarette lighter wiring.
4. Remove (2) screws securing each side of the factory head unit and (1) screw from the rear support.
5. Slide the unit out and disconnect the wiring.

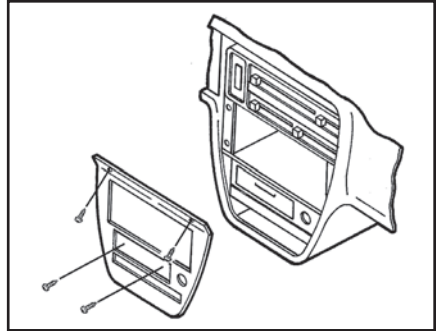

Continue to kit assembly

Chevrolet Monte Carlo 2000-2005

1. Unclip the trim panel above the pedals.
(It is NOT necessary to remove the panel it may be left hanging).
2. Remove (2) 9/32" screws from the knee panel and unclip the panel.
3. Unsnap the driver's side fuse panel cover and remove (1) 9/32" screw.
4. Open the glove box and remove (1) 9/32" screw from the upper left corner.
5. Remove (3) 9/32" screws securing the factory radio and disconnect the wiring.

Continue to kit assembly





Dash Disassembly 99-2011

Chevrolet SSR 2003-2006

1. Unclip and remove the (3) climate control knobs. (Figure A)
2. Unclip and remove the long trim panel below the radio and passenger air bag. (Figure B)
3. Unclip and remove the small trim panel to the left of the steering wheel. (Figure C)
4. Remove the (5) 9/32" screws securing the radio/instrument panel then unclip and remove the panel. (Figure D)
5. Remove the screws securing the factory head unit and disconnect the wiring.

Continue to kit assembly

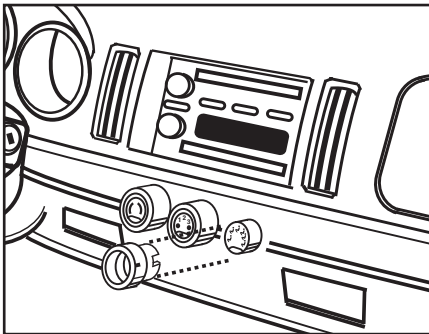

(Figure A)

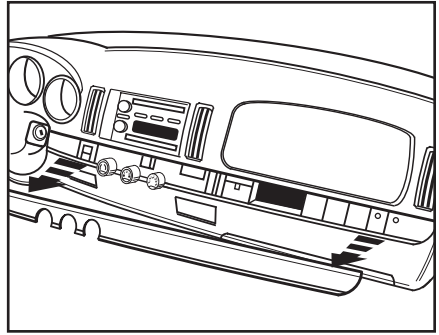

(Figure B)

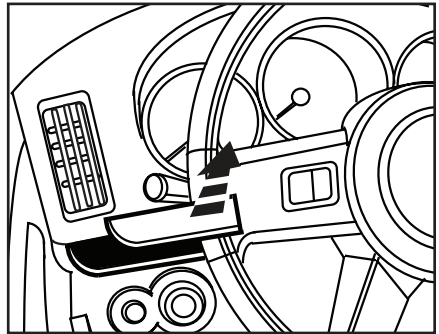

(Figure C)

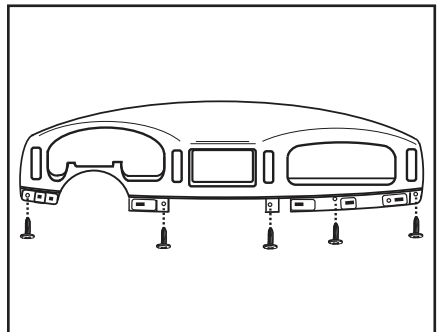

(Figure D)



Dash Disassembly 99-2011

Chevrolet Tracker 1992-2004 Suzuki Sidekick 1992-1998 Suzuki Vitara 1999-2005 Suzuki Grand Vitara 1999-2002 Suzuki xl-7 2001-2002

1. Remove the cigarette lighter and climate control knobs.
2. Remove the ashtray and (1) screw exposed.
3. Pull out on the climate control cluster and remove (2) screws exposed.
4. Unclip the radio trim bezel.
5. Remove (4) screws from the factory head unit, slide the unit out and disconnect the wiring.)

Continue to kit assembly





Dash Disassembly 99-2011

Chevrolet Trailblazer 2002-2009

1. Remove (2) Phillips screws inside instrument cluster.
2. Remove (1) Phillips screw under climate controls to the left of the power outlet.
3. Remove (2) 7 mm hex heads from under steering column and lower the panel. Remove (3) Phillips screws around steering wheel.
4. Unsnap and remove bezel. (*Use caution pulling over hazard switch.*) Remove (3) 7 mm hex head screws to remove radio. *Continue to kit assembly*

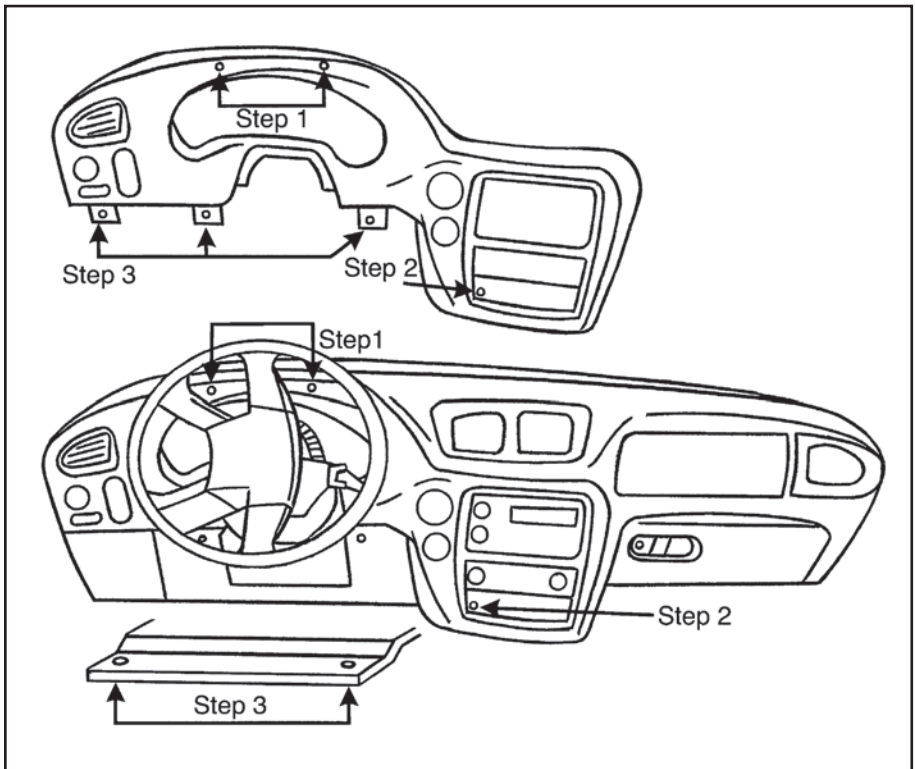



Dash Disassembly 99-2011

Chevrolet Venture 2000 **Oldsmobile Silhouette 2000** **Pontiac Montana 2000** *(Except SV6)*

1. Remove the ashtray and (1) phillips screw exposed in the ashtray cavity.
2. Remove (1) Phillips screw from the cigarette lighter compartment.
3. Remove (2) Phillips screws securing the factory head unit and disconnect the wiring.

Continue to kit assembly

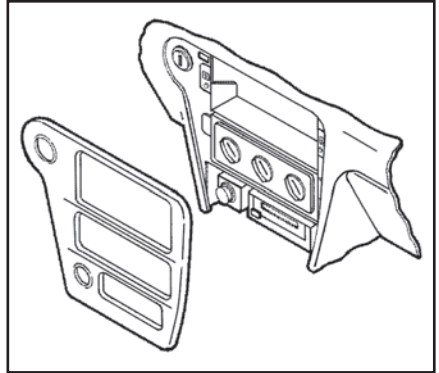



Dash Disassembly 99-2011

Chevrolet Venture 2001-2005 Oldsmobile Silhouette 2001-2004 Pontiac Montana 2001-2005 (Except SV6)

1. Remove the ashtray and (1) phillips screw exposed in the ashtray cavity. (Figure A)
2. Remove (1) Phillips screw from the cigarette lighter compartment. (Figure B and C)
3. Remove (2) Phillips screws securing the factory head unit and disconnect the wiring. (Figure D)

Continue to kit assembly

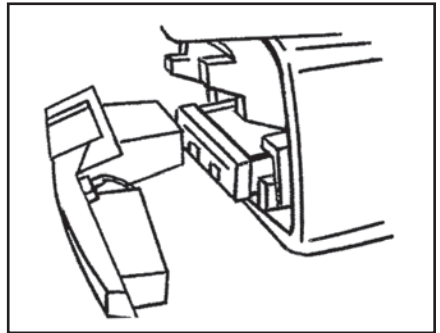

(Figure B)

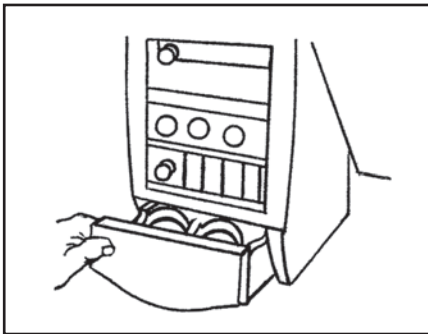

(Figure A)

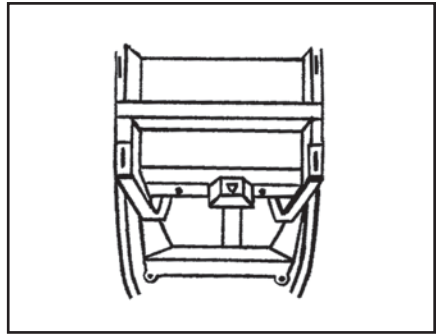

(Figure C)

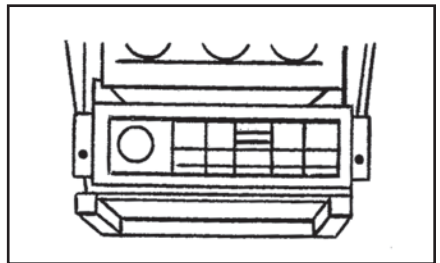

(Figure D)



Dash Disassembly 99-2011

GMC Envoy 2002-2009 Isuzu Ascender 2003-2009 Oldsmobile Bravada 2002-2004 Buick Ranier 2004-2007

1. Remove (4) Phillips screws, (2) from left and (2) from right of carpeted panel. (Figure A)
2. Slide carpeted panel down and backwards to reveal (2) Phillips screws and remove. (Figure B)
3. Unsnap radio bezel and unplug cigarette lighter and accessories. (Figure C)
4. Remove (3) screws and remove radio. (Figure C)

Continue to kit assembly

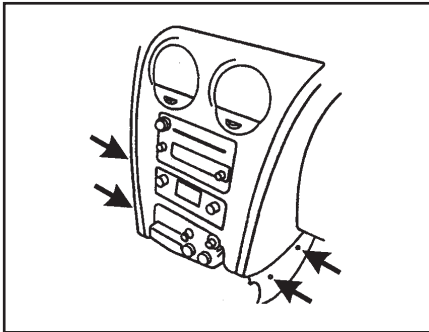

(Figure A)

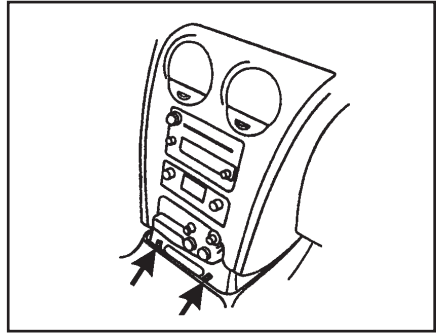

(Figure b)

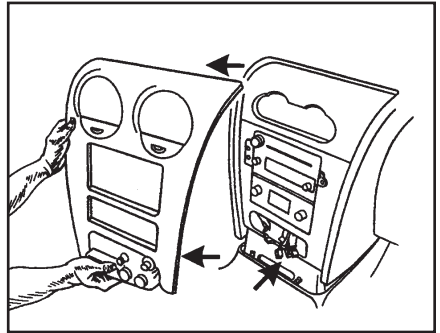

(Figure C)



Dash Disassembly 99-2011

Honda Passport 1998-2002 **Isuzu Amigo 1998-2000** **Isuzu Rodeo 1998-2004** **Isuzu Rodeo Sport 2001-2003**

1. Remove the ashtray and (1) Phillips screw exposed in the ashtray cavity. Unclip and remove the trim panel surrounding the factory radio. Remove (4) Phillips screws securing the factory radio and disconnect the wiring.

Continue to kit assembly

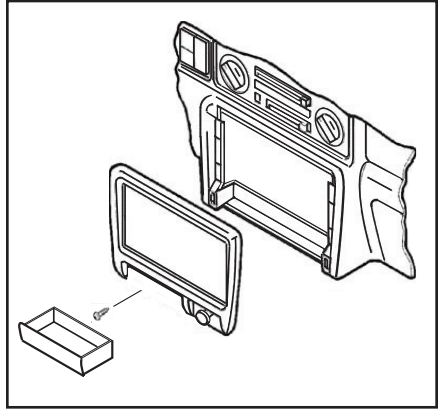



Dash Disassembly 99-2011

Hummer H2 2003-2007

1. Open center console and remove (4) 9/32" screws from console box and remove box. (Figure A)
2. Remove (4) phillips screws from hinge on console door inside console and remove door. (Figure B)
3. Loosen (1) T-15 torx on forward facing side of shift lever and pull up to remove (Figure C)
4. Unclip cup holder/shifter trim assembly and remove. (Figure D)
5. Remove (6) Phillips screws from top of center console.
6. Remove (2) Phillips screws from inside pocket on back of center console, then unclip and remove.

Continued on next page

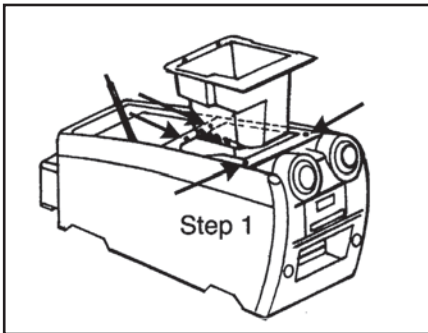

(Figure A)

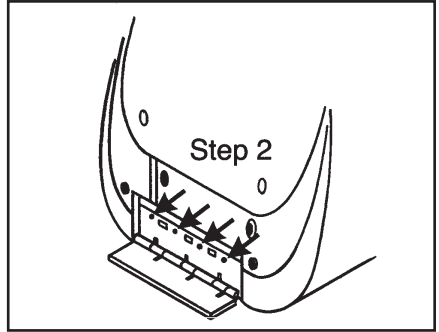

(Figure B)

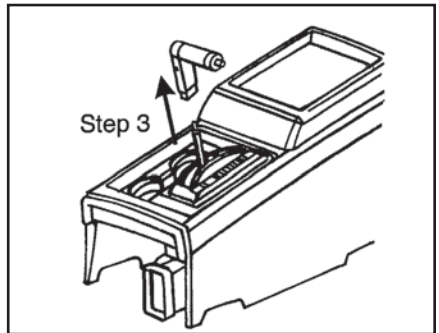

(Figure C)

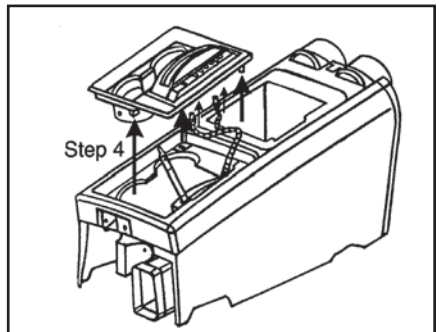

(Figure D)



Dash Disassembly 99-2011

Hummer H2 2003-2007

7. Remove (1) 10 mm bolt to right of shift lever. (Figure A)
8. Remove (2) Phillips screws from under console box on drivers side and (2) Phillips screws from under console trintop on passenger side. (Figure A)
9. Slide control assembly rearwards. (Figure B)
10. Remove (2) T-30 torx bolts from top of rado/climate control trim and unclip and remove. (Figure C)
11. Remove (3) 9/32" screws that hold the radio in. (Figure C)

Continue to kit assembly

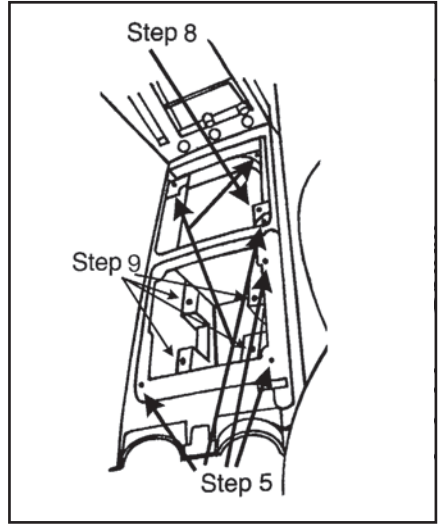

(Figure B)

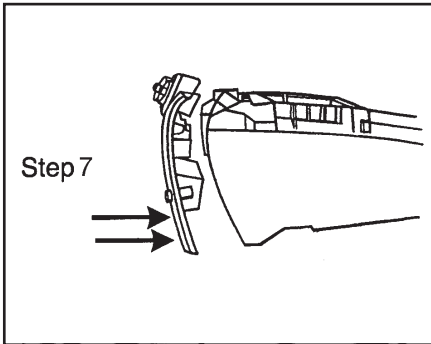

(Figure A)

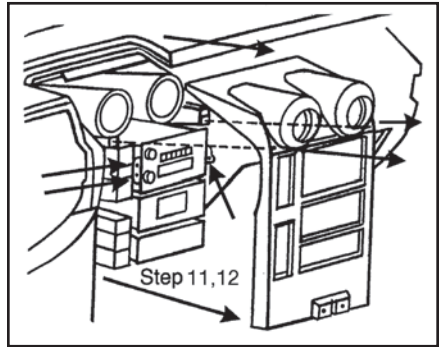

(Figure C)



Dash Disassembly 99-2011

Oldsmobile Achieva 1996-1998

1. Open the glove box, press inward on the walls of the glove box liner and remove the liner.
2. Remove (10) torx-head screws from the glove box location.
3. Remove (2) 9/32" hex-head screws under the steering column.
4. Unclip the dash trim bezel.
5. Remove the screws securing the factory head unit and disconnect the wiring.

Continue to kit assembly

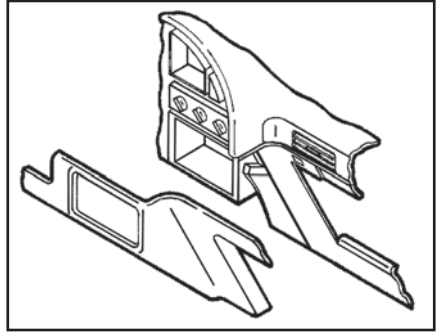

Oldsmobile Alero 1999-2004

1. Remove shift knob by using a small screwdriver to remove U-clip from front of shifter and pull upward.
2. Unclip and remove shifter trim panel.
3. Unclip and remove radio and climate control panel by pulling from bottom.
4. Remove (3) 9/32" screws from radio and remove.

Continue to kit assembly

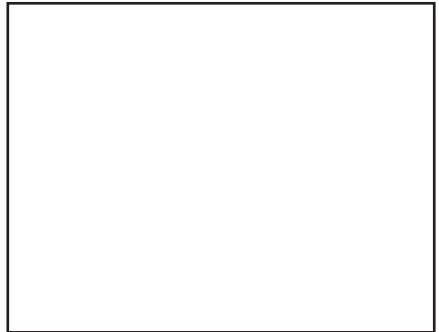



Dash Disassembly 99-2011

Oldsmobile Aurora 1995-2003

1. Unclip the radio trim bezel and remove the bezel.
2. Remove (2) 7 mm screws securing the factory head unit and disconnect the wiring.

Continue to kit assembly

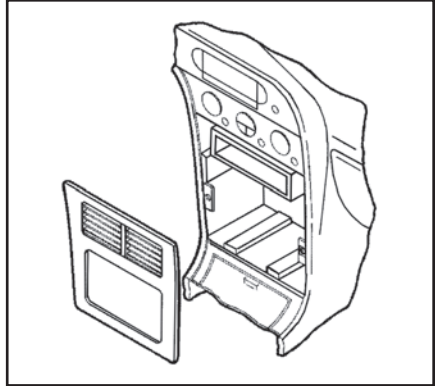

Oldsmobile Cutlass 1997-1999 Oldsmobile Cutlass Supreme 1995-1997

1. Unclip the radio trim bezel and remove.
2. Remove (2) 9/32" hex-head screws securing the factory head unit and disconnect the wiring.

Continue to kit assembly

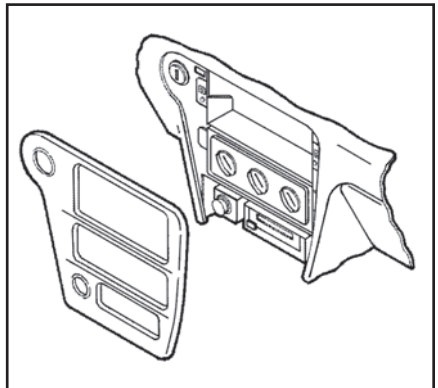



Dash Disassembly 99-2011

Oldsmobile Eighty-Eight 1994-1999

1. Unclip the radio trim bezel and remove.
2. Remove (2) 9/32" hex-head screws securing the factory head unit and disconnect the wiring.

Continue to kit assembly

Oldsmobile Ninety-Eight 1994-1996

1. Open the glove box and remove (2) hex-head screws securing the wood trim.
2. Unsnap the wood trim and remove.
3. Remove (2) hex-head screws below the radio trim bezel.
4. Lift up on the bezel and remove.
5. Remove (3) Phillips hex-head screws securing the factory head unit and disconnect the wiring.

Continue to kit assembly

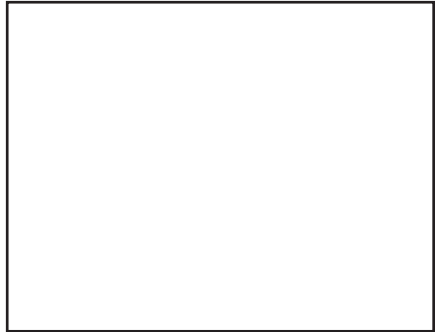

Oldsmobile Intrigue 1998-2002

1. Open the center console storage compartment and remove (2) 9/32" hex-head screws exposed.
2. Remove the center console.
3. Unclip the radio trim bezel and remove.
4. Remove (2) 9/32" hex-head screws securing the factory head unit and disconnect the wiring.

Continue to kit assembly

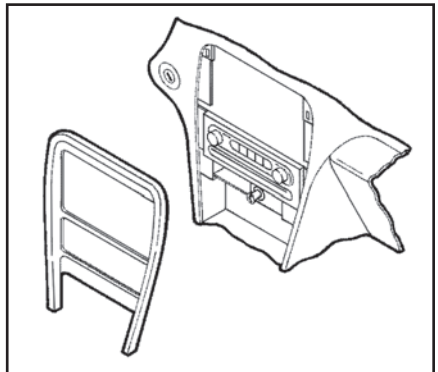



Dash Disassembly 99-2011

Oldsmobile LSS 1996-1999 Oldsmobile Regency 1997-1998

1. Open glove box and remove two-center trim bezels attached by screws. (Figure A)
2. Unsnap and remove radio trim bezel. (Figure A)
3. Remove (3) 9/32" hex-head screws and remove radio. (Figure B)
Continue to kit assembly

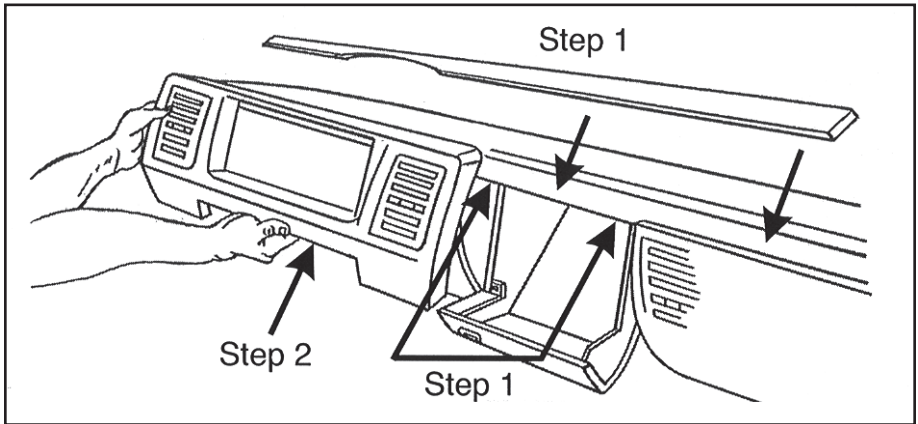

(Figure A)

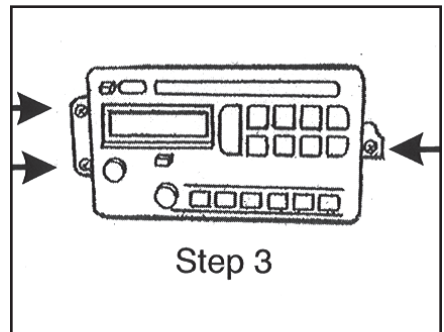

(Figure B)



Dash Disassembly 99-2011

Pontiac Aztec 2001-2005

1. Pull out cup holder inserts.
2. Remove (1) Phillips screw exposed inside bottom cup holder.
3. Unsnap and remove shifter trim with cup holders.
4. Remove (2) #15 torx at bottom of radio/ climate bezel.

Continue to kit assembly

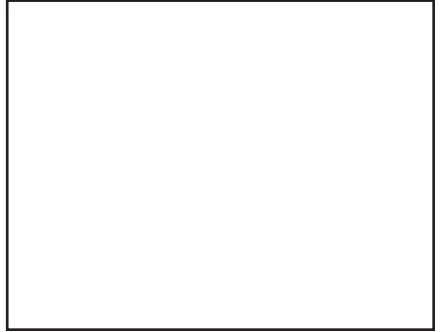

Pontiac Bonneville 2000-2005

1. Remove (2) Phillips screws from the instrument cluster. (Figure A)
2. Unclip the ignition trim and remove. (Figure B)
3. Unclip the climate control/radio trim bezel and remove.
4. Depress the spring clips on each side of the factory head unit and remove. (Figure C)

Continue to kit assembly

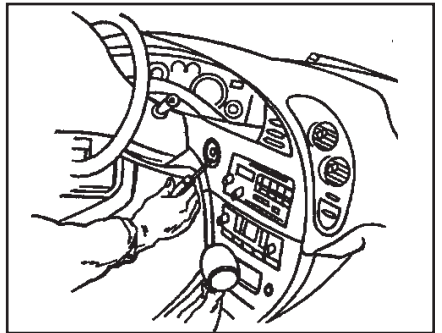

(Figure B)

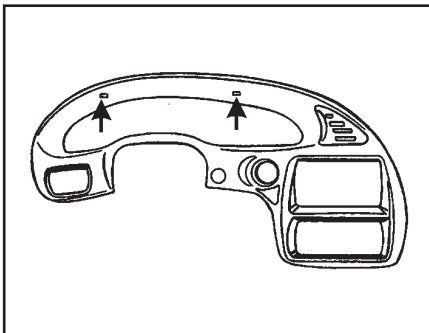

(Figure A)

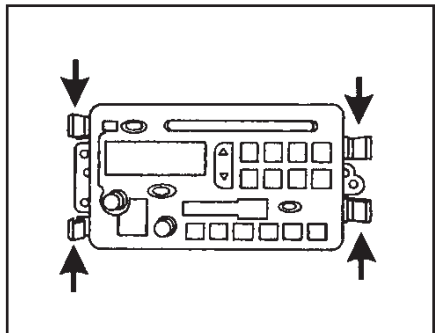

(Figure C)



Dash Disassembly 99-2011

Pontiac Grand Am 2001-2005

1. Unsnap and remove radio trim bezel.
2. Remove (3) 9/32" screws from radio brackets and remove radio.

Continue to kit assembly

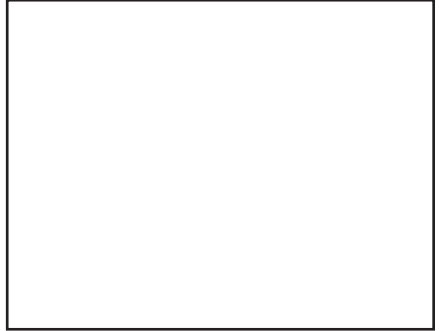

Pontiac Sunfire 2000-2005

1. Open the glove box and remove (2) Phillips screws exposed on the right edge of the radio trim bezel.
2. Unclip the bezel and remove.
3. Remove (2) 7 mm hex-head screws securing the factory head unit and disconnect the wiring.

Continue to kit assembly

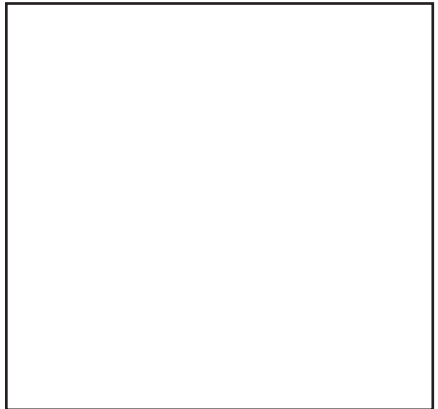



Dash Disassembly 99-2011

Pontiac Vibe 2003-2008 Toyota Matrix 2003-2004

1. Unclip the bottom edge of the radio trim panel then lift up and out to remove. (Figure A)
2. Remove (4) 10 mm bolts securing the factory radio. (Figure B)

Continue to kit assembly

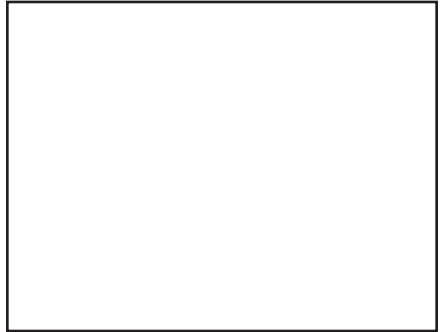

(Figure A)

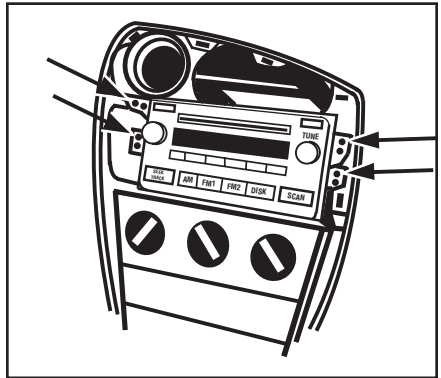

(Figure B)



Dash Disassembly 99-2011

Suzuki Aerio 2002

1. Unclip the dash trim bezel and remove.
2. Remove (4) Phillips screws securing the factory head unit and disconnect the wiring.

Continue to kit assembly

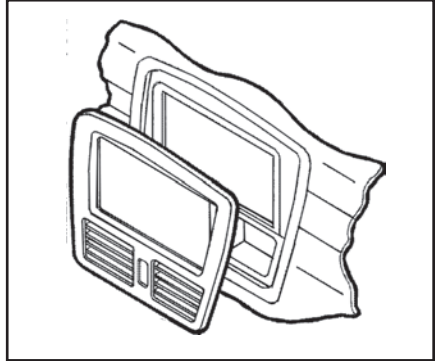

Suzuki Esteem 1995-2003

1. Remove the climate control knobs.
2. Remove (1) Phillips screw located above the radio opening.
3. Unclip the radio trim bezel.
4. Remove (4) screws from the factory head unit, slide the unit out and disconnect the wiring.

Continue to kit assembly

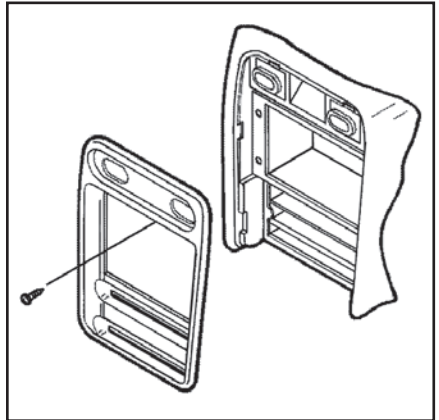



Tab Instructions 99-2011

Chevrolet/GM/Metro/Suzuki Cadillac Fleetwood/Brougham

1. GM vehicles.

Cut tabs highlighted on both sides of both brackets. (Figure A)

2. Chevy Tracker/Metro/Suzuki.

Cut tabs highlighted on both sides of both brackets. (Figure B)

3. Cadillac Fleetwood/Brougham.

Cut all tabs highlighted on both sides of both brackets. (Figure C)

Continued on next page

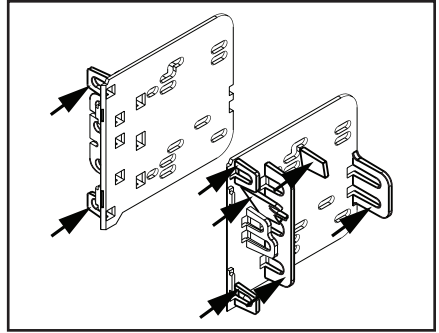

(Figure A)

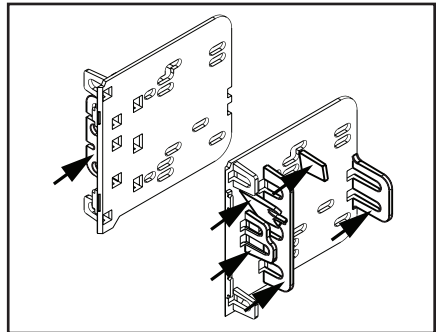

(Figure B)

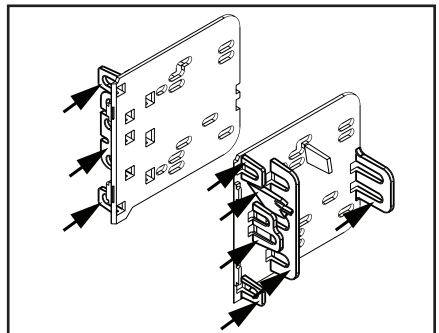

(Figure C)



Tab Instructions 99-2011

Isuzu/Pontiac/Toyota Cadillac Eldorado/Seville

4. **Isuzu Amigo/Rodeo/Rodeo Sport.**
Cut tabs highlighted. (Figure D)

5. **Toyota Matrix/Pontiac Vibe.**
Cut tabs highlighted. (Figure E)
Cut (4) tabs highlighted on double
DIN trim plate. (Figure H)

6. **Cadillac Eldorado/Seville.**
Cut tabs highlighted on double
DIN brackets. (Figure F) Cut (1) tab
highlighted on top left corner of double
DIN trim plate. (Figure G)

Continue to kit assembly

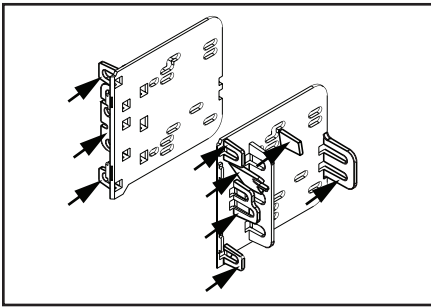

(Figure D)

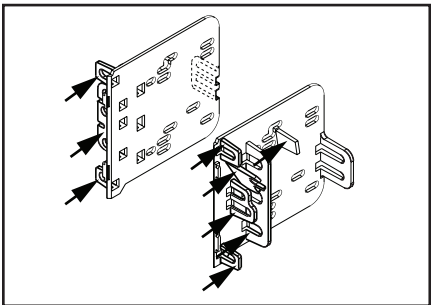

(Figure E)

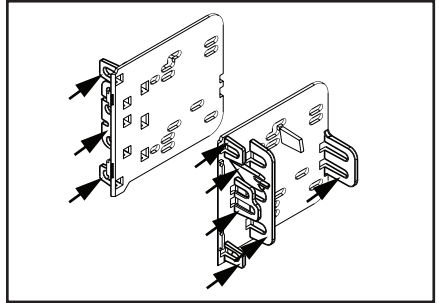

(Figure F)

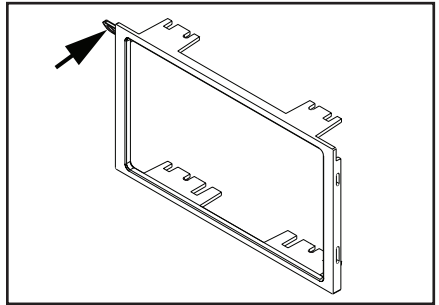

(Figure G)

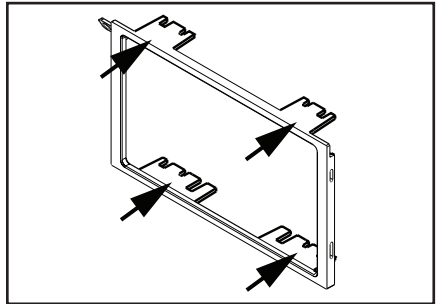

(Figure H)



Kit Assembly 99-2011

Cadillac Fleetwood/Brougham 1990-1996

(With factory brackets)

1. Locate the factory wiring harness in the dash. Metra recommends using the proper mating adapter from Metra or AXCESS. Re-connect the negative battery terminal and test the unit for proper operation.
2. Using carriage bolts and Keps nuts supplied, mount the factory brackets to the double DIN trim plate/double DIN bracket assembly, keeping in mind which bracket is top and which one is bottom.
3. Reassemble dash in reverse order of disassembly.

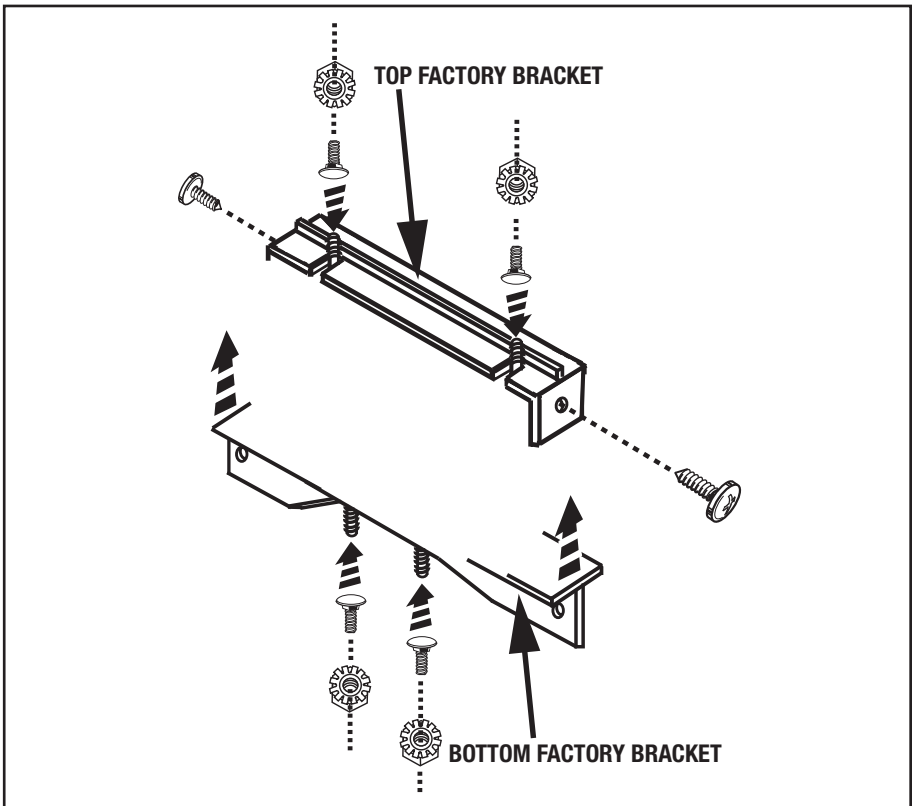



Kit Assembly 99-2011

Cadillac Eldorado 1992-1995 Cadillac Seville 1992-1995

1. Locate the factory wiring harness in the dash. Metra recommends using the proper mating adapter from Metra or AXXESS. Re-connect the negative battery terminal and test the unit for proper operation.
2. Align the tabs on the bottom of the double DIN trim plate with the notches in sub dash.
3. Secure with the (2) Carriage bolts and (2) Kep nuts provided.
4. Reassemble dash in reverse order of disassembly.

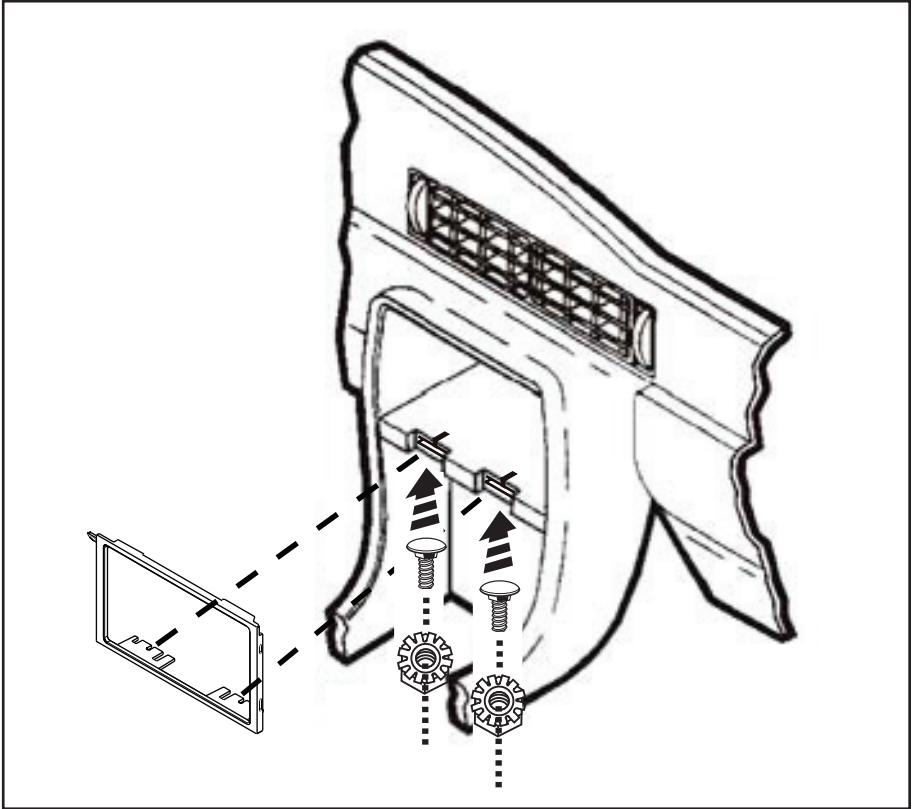



Kit Assembly 99-2011

Double DIN radio provision

1. Locate the factory wiring harness in the dash. Metra recommends using the proper mating adapter from Metra or AXCESS. Re-connect the negative battery terminal and test the unit for proper operation.
2. Snap the Double DIN brackets to the edge of the Double DIN trim plate. (Figure A)
3. Slide the Double DIN head unit or stacked ISO head units into the bracket/radio housing assembly and secure the Double DIN head unit or stacked ISO head units to the assembly using the screws supplied with the radio. (Figure B)

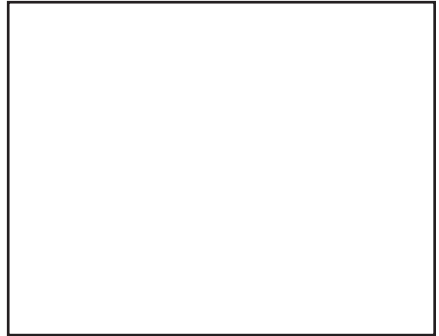

(Figure A)

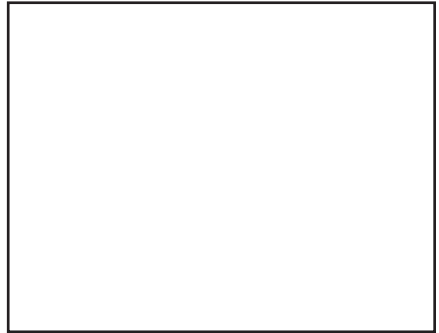

(Figure B)

- Note: For the Buick Le Sabre, Oldsmobile Aurora and the Pontiac Bonneville the (3) speed clips and screws provided with the kit will need to be installed into the sub dash where the screw holes line up on the kit.***
4. Reassemble dash in reverse order of disassembly.



Kit Assembly 99-2011

ISO DIN head unit provision with pocket

1. Mount the pocket to the radio brackets with the (4) #8 x 3/8" Phillips screws supplied. (Figure A)
2. Slide the head unit into the radio brackets and secure with screws supplied with the unit. (Figure B)

Note: For the Buick Le Sabre, Oldsmobile Aurora and the Pontiac Bonneville the (3) speed clips and screws provided with the kit will need to be installed into the sub dash where the screw holes line up on the kit.

3. Clip the trim plate/housing over the radio/pocket assembly. (Figure B)
4. Locate the factory wiring harness in the dash. Metra recommends using the proper mating adapter from Metra or AXCESS. Re-connect the negative battery terminal and test the unit for proper operation.
5. Mount the new radio assembly into the dash and reassemble dash in reverse order of disassembly.

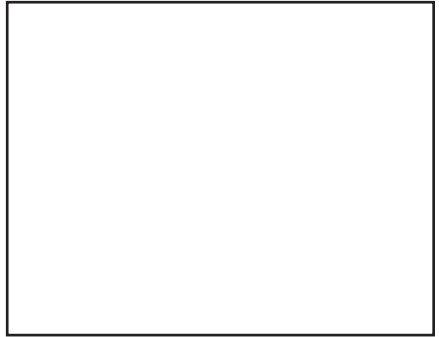

(Figure A)

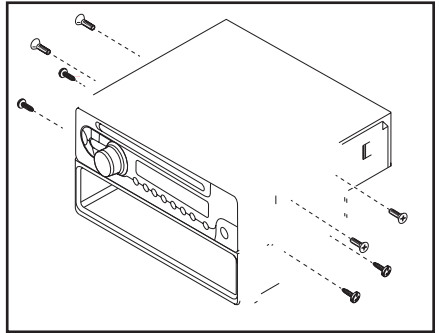

(Figure B)