

April 6th, 2016

Presenter: Mr. John Malinowski, ABB Baldor

Title: The Impact of the Integral Horsepower Amended Rule
(1 – 500 HP motors)

Event to start shortly

Scheduled time: 11:00 USA Eastern Standard Time



Webinar Presenter: Mr. John Malinowski

- Senior Manager for Industry Affairs at Baldor Electric Company in Fort Smith, AR.
- Active in IAS Pulp & Paper Industry Committee, and Petroleum and Chemical Industry Committee
- Serves on several IEEE Standards Working Groups
 - Immediate Past Chairman of NEMA MG1 Motor & Generator Section
 - Baldor's representative for several energy advocate organizations
- Published numerous articles on motor and drive efficiency, maintenance and applications



Outline

- History of Efficiency Regulations
- Integral Horsepower Amended Motor Rule
- Motor regulation a logical progression



Motor Efficiency Regulations

Energy Policy Act of 1992

- Effective October 1997
- General Purpose 1 – 200 HP at MG 1, table 12-11 Energy Efficient

Energy Policy Act of 2005

- Raised purchases for government to table 12-12 Premium Efficient [by executive order from President]

Energy Independence & Security Act of 2007

- Effective December 2010
- General Purpose 1-200 HP EPAAct motors to table 12-12 Premium Efficient
- Other 1-200 HP motors at table 12-11 Energy Efficient
- 201 – 500 HP motors at 12-11 Energy Efficient

Motor Coalition Formed in 2010

- Determine the greatest energy savings potential and improve enforcement
- Agreement on action plan to achieve
 - Legislation?
 - Regulation?
- Product definitions –
 - Electrical and mechanical considerations
- Testing issues mechanical adoptions
- Metrics – nominal efficiency at 100% load
- MEPS – Minimum efficiency levels
- Timing of implementation

The Motor Coalition Members

- American Council for an Energy-Efficient Economy
- Alliance to Save Energy
- Appliance Standards Awareness Project
- Earthjustice
- Natural Resources Defense Council
- Northeast Energy Efficiency Partnerships
- Northwest Energy Efficiency Alliance
- National Electrical Manufacturers Association
- Pacific Gas and Electric
- Others signed letters of support

2010-11 Motor Coalition Strategy

- Determine and document a plan to improve the efficiency of the greatest number of units providing the **greatest savings impact** while **reducing potential enforcement issues** while maintaining **full product utility** for American industry
- Deliver a plan to DOE as a **platform for a consensus recommendation** that can be acted upon within the **least amount of time** delivering **large net benefits**.
- **Move to a final rule with the least delay to deliver results that save greatest energy as quickly as possible**

EISA 2007 required a Final IHP Rule by December 19th 2012

Motors must meet 7 standard DOE criteria

Energy Policy & Conservation Act of 1975 Factors	DOE Analysis
1. Economic impact on consumers and manufacturers	Life-cycle cost analysis Manufacturer impact analysis
2. Lifetime operating cost savings compared to increased cost for the product	Life-cycle cost analysis
3. Total projected savings	National impact analysis
4. Impact on utility or performance	Engineering analysis Screening analysis
5. Impact of any lessening of competition	Manufacturer impact analysis
6. Need for national energy conservation	National impact analysis
7. Other factors the Secretary considers relevant	Environmental assessment Utility impact analysis Employment impact analysis

Amended Integral HP Rule

Published May 29th 2014 DOE amends motor efficiency regulations

DEPARTMENT OF ENERGY

10 CFR Part 431

[Docket No. EERE-2010-BT-STD-0027]

RIN 1904-AC28

Energy Conservation Program: Energy Conservation Standards for Commercial and Industrial Electric Motors

Integral HP Motor Final Rule

- Replaces Energy Independence & Security Act of 2007
- Takes effect 24 months after Final Rule (June 1, 2016)
- Almost all motors will be covered at Premium Efficiency levels NEMA MG 1, Table 12-12 or Part 20, Table B (IE3)
- Simplifies enforcement and compliance
- Improved definitions and testing guidelines

Compare Integral Rule to EISA

Motor Type	EISA	New Integral HP Rule
1-200 HP Subtype I	Premium Efficient NEMA MG 1, Table 12-12	Premium Efficient NEMA MG 1, Table 12-12
1-200 HP Subtype II	Energy Efficient NEMA MG 1, Table 12-11	Premium Efficient NEMA MG 1, Table 12-12
201-500 HP	Energy Efficient NEMA MG 1, Table 12-11	Premium Efficient NEMA MG 1, Table 12-12 & 20-B
56 Frame Enclosed	Exempt	Premium Efficient NEMA MG 1, Table 12-12
Custom Configurations	Exempt	Premium Efficient NEMA MG 1, Table 12-12
1-200 HP Fire Pump Motors	Energy Efficient NEMA MG 1, Table 12-11	Energy Efficient NEMA MG 1, Table 12-11

Motors covered under IHP Final Rule

The motors regulated under expanded scope meet the following nine characteristics:

1. Is a single speed induction motor
2. Is rated for continuous duty (MG 1) operation or for duty type S1 (IEC)
3. Contains a squirrel-cage (MG 1) or cage (IEC) rotor
4. Operated on polyphase alternating current (AC) 60-hertz sinusoidal line power
5. Has 2-, 4-, 6-, or 8-pole configuration
6. Is rated 600 volts or less
7. Have a three or four digit NEMA frame size (or IEC metric equivalent), including those designs between two consecutive NEMA frame sizes (or IEC metric equivalent) or an enclosed 56 NEMA Frame size (or IEC metric equivalent).
8. Has no more than 500 horsepower, but greater than or equal to 1 horsepower (or kilowatt equivalent)
9. Meets all the performance requirements of a NEMA design A, B or C electric motor or an IEC design N or H electric motor.

Table 5—Nominal Full-Load Efficiencies of NEMA Design A, NEMA Design B and IEC Design N Motors (Excluding Fire Pump Electric Motors) at 60 Hz

Motor horsepower/ standard kilowatt equivalent	Nominal full-load efficiency (%)							
	2 Pole		4 Pole		6 Pole		8 Pole	
	Enclosed	Open	Enclosed	Open	Enclosed	Open	Enclosed	Open
1/.75	77.0	77.0	85.5	85.5	82.5	82.5	75.5	75.5
1.5/1.1	84.0	84.0	86.5	86.5	87.5	86.5	78.5	77.0
2/1.5	85.5	85.5	86.5	86.5	88.5	87.5	84.0	86.5
3/2.2	86.5	85.5	89.5	89.5	89.5	88.5	85.5	87.5
5/3.7	88.5	86.5	89.5	89.5	89.5	89.5	86.5	88.5
7.5/5.5	89.5	88.5	91.7	91.0	91.0	90.2	86.5	89.5
10/7.5	90.2	89.5	91.7	91.7	91.0	91.7	89.5	90.2
15/11	91.0	90.2	92.4	93.0	91.7	91.7	89.5	90.2
20/15	91.0	91.0	93.0	93.0	91.7	92.4	90.2	91.0
25/18.5	91.7	91.7	93.6	93.6	93.0	93.0	90.2	91.0
30/22	91.7	91.7	93.6	94.1	93.0	93.6	91.7	91.7
40/30	92.4	92.4	94.1	94.1	94.1	94.1	91.7	91.7
50/37	93.0	93.0	94.5	94.5	94.1	94.1	92.4	92.4
60/45	93.6	93.6	95.0	95.0	94.5	94.5	92.4	93.0
75/55	93.6	93.6	95.4	95.0	94.5	94.5	93.6	94.1
100/75	94.1	93.6	95.4	95.4	95.0	95.0	93.6	94.1
125/90	95.0	94.1	95.4	95.4	95.0	95.0	94.1	94.1
150/110	95.0	94.1	95.8	95.8	95.8	95.4	94.1	94.1
200/150	95.4	95.0	96.2	95.8	95.8	95.4	94.5	94.1
250/186	95.8	95.0	96.2	95.8	95.8	95.8	95.0	95.0
300/224	95.8	95.4	96.2	95.8	95.8	95.8		
350/261	95.8	95.4	96.2	95.8	95.8	95.8		
400/298	95.8	95.8	96.2	95.8				
450/336	95.8	96.2	96.2	96.2				
500/373	95.8	96.2	96.2	96.2				

Motors added previously not covered by EISA

What additional designs are covered:

- NEMA Design A motors from 201-500 HP
- Electric motors with moisture-resistant windings, sealed or encapsulated windings
- Partial electric motors including gearmotors
- Totally-enclosed non-ventilated (TENV) electric motors
- Immersible electric motors
- Integral or non-integral brake electric motors
- U-frame motors
- Design C motors
- IEC 100 frame
- Electric motors with non-standard endplates or flanges
- Electric motors with non-standard base or mounting feet
- Footless motors (C-face or D-flange less base)
- Electric motors with special shafts
- Close-coupled pump motors
- 56J Jet pump motors (Enclosed)
- Vertical hollow shaft electric motors
- Vertical medium and high thrust solid shaft electric motors
- Electric motors with sleeve bearings
- Electric motors with thrust bearings
- Pre-NEMA frame motors
- Form wound motors <600 volts

Motors not covered under IHP final rule

Exempt Motors:

- Single phase ODP motors (may be covered by Small Motor Rule)
- Single phase Enclosed motors
- DC motors
- Two digit frames (42 – 48) (may be covered by Small Motor Rule)
- 56 frame ODP (may be covered by Small Motor Rule)
- Multi-speed motors
- Medium voltage motors
- TEAO or Open Air-over motors
- Submersible motors
- Water-cooled motors
- Intermittent duty motors (S2-S8)
- Stator-rotor sets
- Design D motors
- Motors designed for Inverter Power (MG 1, Part 31) with no line start
- Synchronous AC motors
- Permanent magnet rotor AC motors
- Servo motors

Partial (3/4 Motor) vs. Stator-Rotor Set

- Partial motors usually have the drive endplate missing and used as part of a gear motor, pump or compressor.
 - A partial motor may have an endplate installed and tested before shipment.
- A stator and rotor may or may not have a shaft or frame casting.
 - They are transformed into a motor down stream by someone other than the component manufacturer.
 - That transforming company becomes the motor manufacturer for DOE compliance.



Impact to OEMs and End Users

Form, Fit, Function

- Previously unregulated motors may be larger size
- Premium motors have less slip – higher speed
- Some designs may be Design A – higher inrush current
- Some designs in larger NEMA frame



Impact to OEMs and End Users

- Life Cycle Value
 - More material – additional cost for premium efficiency
 - Motor cost 2% - 97% for electricity
 - Can continue to buy and use motors built before June 1, 2016
- Remember the regulation is point of manufacture, not the end user
- Significantly adds embedded motors as covered products

Progression of Active Material Required to Increase Efficiency

Lowest level
Exempt IE1

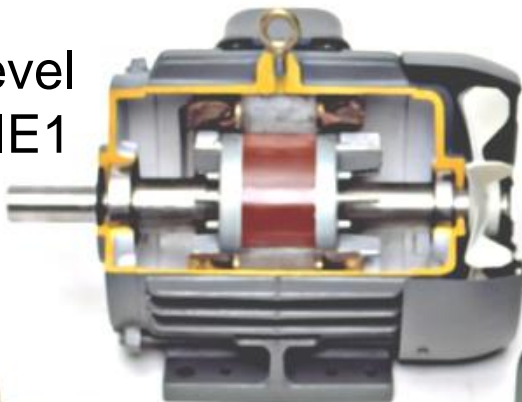

NEMA Premium
12-12 IE3

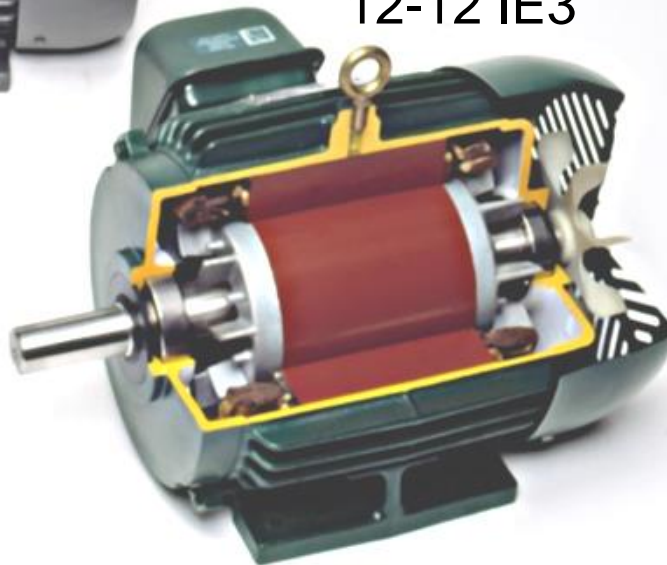

EPAct 92
NEMA 12-11
IE2



Affect of Expanded Product Scope

Millions of units per year

Total 5.6 million motors sold in USA typical year

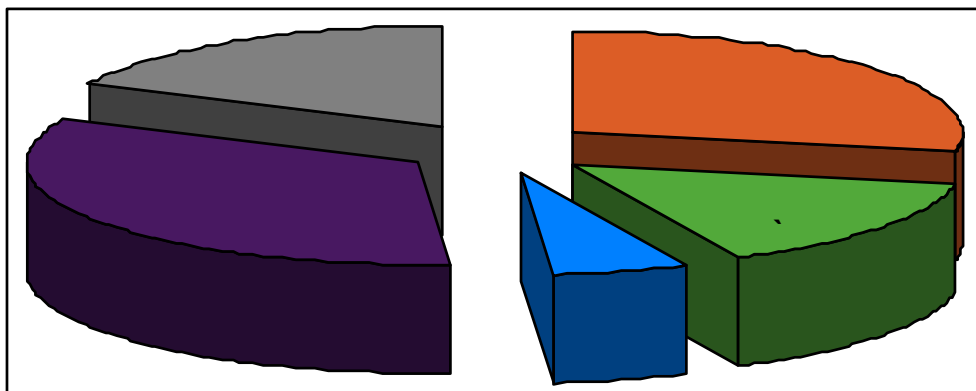

Motor rule amendment adds nearly 4 million motors in four new categories

■ Type 1 and 2

■ Partial & Gearmotor

■ Definite & Special

■ Imported motors or component

■ 56 Frame

Amended rule conclusions

- Expands the definition of covered product adding over 4 million units per year to be regulated
- Reduces non-covered motors to a small number
- Saves more energy than any rule ever issued by DOE
- Reduces confusion for enforcement agencies
- Allows distributors and resellers to “work through” existing inventories of current product
- Continues to use NEMA standards and table 12-12 as minimum performance levels protecting end user and OEM product utility
- Takes affect June 1st 2016
- Continues to use NEMA standards, IEEE and CSA test methods

IAS WEBINAR SERIES

Questions and Answers

April 6th, 2016

Presenter: Mr. John Malinowski, ABB Baldor

Title: The Impact of the Integral Horsepower Amended Rule
(1 – 500 HP motors)

If you have any question for the presenter:
Use the Webex Q&A tab to send your question to the moderator

IAS WEBINAR SERIES CONCLUSION

We thank the presenter, John Malinowski,
and we thank you for your attention

This session was recorded and will be posted on line at:
www.ias.ieee.org

Next webinar: May 4th, 2016
Presenter: Dr. John Palmour, CEO, Wolfspeed
Title: Wide bandgap semiconductors

Actual presentation

- ❑ Should include IAS logo on each slide and statement “IAS webinar series” at the bottom of each slide
- ❑ Presenter can otherwise customize the format in any way he/she pleases, including employer’s logo, etc