



# Artisan® Siding with Lock Joint System

SINGLE FAMILY INSTALLATION REQUIREMENTS

EFFECTIVE MAY 2019

IMPORTANT: FAILURE TO FOLLOW JAMES HARDIE WRITTEN INSTALLATION INSTRUCTIONS AND COMPLY WITH APPLICABLE BUILDING CODES MAY VIOLATE LOCAL LAWS, AFFECT BUILDING ENVELOPE PERFORMANCE AND MAY AFFECT WARRANTY COVERAGE. FAILURE TO COMPLY WITH ALL HEALTH AND SAFETY REGULATIONS WHEN CUTTING AND INSTALLING THIS PRODUCT MAY RESULT IN PERSONAL INJURY. BEFORE INSTALLATION, CONFIRM YOU ARE USING THE CORRECT HARDIEZONE® PRODUCT INSTRUCTIONS BY VISITING HARDIEZONE.COM OR CALL 1-866-942-7343 (866-9-HARDIE).

All profiles can be installed horizontally, vertically, and as soffit.

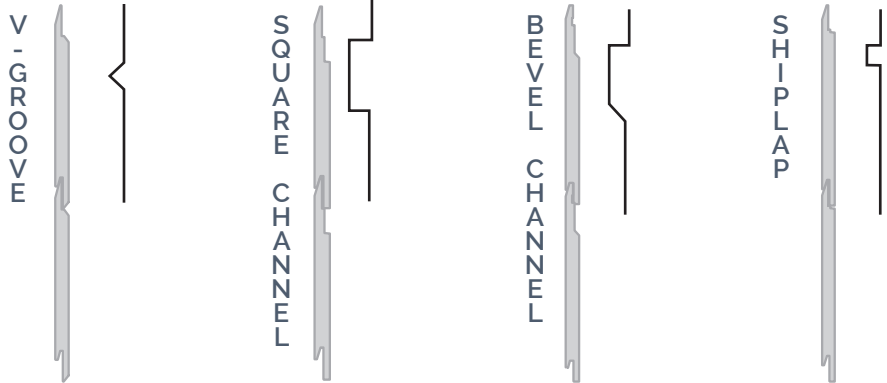

## STORAGE

Store flat and keep dry and covered prior to installation. Installing siding wet or saturated may result in shrinkage at joints. Protect edges and corners from breakage. James Hardie is not responsible for damage caused by improper storage and handling of the product

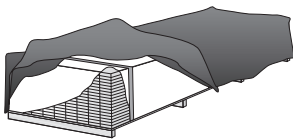

## HANDLING

To prevent damage to edges, extra care should be taken when removing planks from the pallet, while handling, and when installing. Planks are interlocked together on the pallet, therefore they should be removed from the pallet horizontally (side to side) to allow planks to unlock themselves from one another.

PULL FROM ACROSS THE STACK

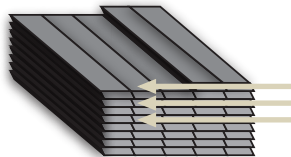

DO NOT GO DOWN THE STACK

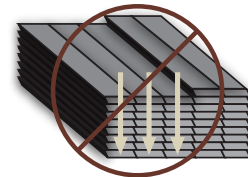

## CUTTING INSTRUCTIONS

1. Position cutting station so that wind will blow dust away from user and others in working area.
2. Use one of the following methods:
  - a. **Best:** Circular saw equipped with a HardieBlade® saw blade and attached vacuum dust collection system
  - b. **Better:** Circular saw equipped with a HardieBlade saw blade and a dust collection feature (e.g. Roan® Saw)
  - c. **Good:** Circular saw equipped with a HardieBlade saw blade

**For maximum dust reduction,** James Hardie recommends using the “Best” cutting practices.

**For best performance** when cutting with a circular saw, James Hardie recommends using HardieBlade saw blades.

- **NEVER** grind or cut with a power saw indoors.
- **NEVER** dry sweep dust; use wet dust suppression or vacuum to collect dust.

NOTE: James Hardie makes no representation or warranty that use of a particular cutting option will assure your compliance with applicable laws and safety requirements. If you are unsure which cutting option is best for your jobsite, consult a qualified industrial hygienist or safety professional, or contact your James Hardie representative for assistance.



V-GROOVE | SQUARE CHANNEL | BEVEL CHANNEL | SHIPLAP

Visit [aspyredesign.com](http://aspyredesign.com) for the most recent version.



ASP1835 P1/7 04/19



### GENERAL REQUIREMENTS

- These instructions are to be used for single family installations only. For Commercial / Multi-Family installation requirements go to [www.JamesHardiePros.com](http://www.JamesHardiePros.com)\*
- References to the 2015 National Building Code (NBC) of Canada are made throughout this document. Local building code requirements may supersede the NBC in some locations.
- Where local building code requires a capillary break (Rainscreens, Furring, Etc.), fastener specifications per the Technical Data Sheet can still be used as long as the require fastener penetration is achieved into an approved nailable substrate.
- Artisan siding can be installed over braced wood or steel studs, 20 gauge (0.836 mm) minimum to 16 gauge (1.367 mm) maximum, spaced a maximum of 610 mm (24 in) o.c., or directly to minimum 7/16 in thick OSB sheathing. See General Fastening Requirements. Irregularities in framing and sheathing can mirror through the finished application.
- Information on installing James Hardie products over foam can be located in JH Tech Bulletin 19 at [www.aspyredesign.com](http://www.aspyredesign.com)
- A water-resistive barrier is required in accordance with Part 9.27.3.2 of the NBC. The water-resistive barrier must be appropriately installed with penetration and junction flashing in accordance with Part 9.27.3 of the NBC. James Hardie will assume no responsibility for water infiltration.
- Do not install James Hardie® products, such that they may remain in contact with standing water.
- Adjacent finished grade must slope away from the building in accordance with local building codes - typically a minimum of 6 in. in the first 10 ft.
- Do not use Artisan® siding in fascia or trim applications
- Artisan siding may be installed on vertical wall applications only.
- When installing James Hardie® products all clearance details in figs. 10-13 must be followed.
- For larger projects, including commercial and multi-family projects, where the span of the wall is significant in length, the designer and/or architect should take into consideration the coefficient of thermal expansion and moisture movement of the product in their design. These values can be found in the Technical Bulletin "Expansion Characteristics of James Hardie® Siding Products" at [www.JamesHardie.com](http://www.JamesHardie.com).
- James Hardie Building Products may be installed on buildings with a maximum mean roof height of 25.9 m (85 ft).

### CLEARANCE AND FLASHING REQUIREMENTS

Figure 1  
Roof to Wall

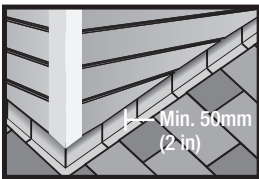

Figure 2  
Horizontal Flashing

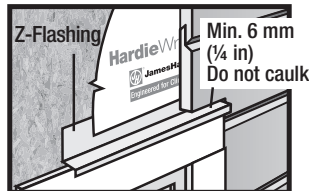

Figure 3  
Kickout Flashing

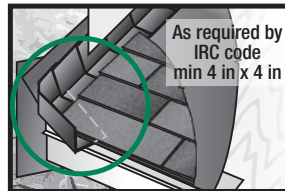

Figure 4  
Slabs, Path, Steps to Siding

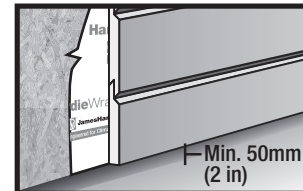

Figure 5  
Deck to Wall

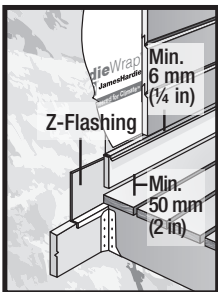

Figure 6  
Ground to Siding

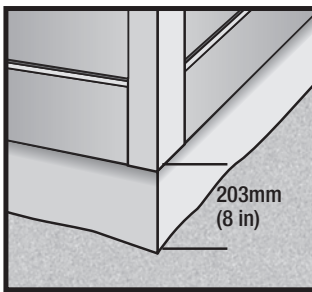

Figure 7  
Gutter to Siding

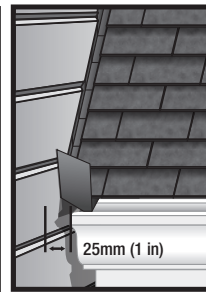

Figure 8  
Sheltered Areas

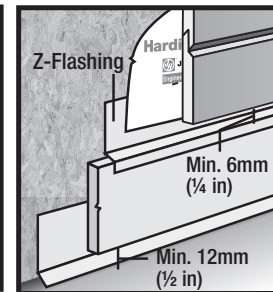

Figure 9  
Mortar/Masonry

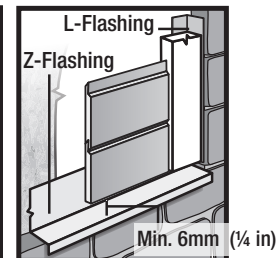

Figure 10  
Drip Edge

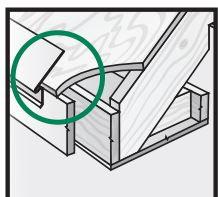

Figure 11  
Block Penetration

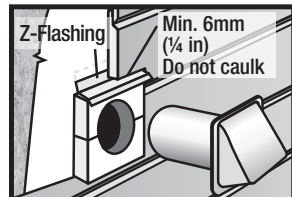

Figure 12  
Valley/Shingle Extension

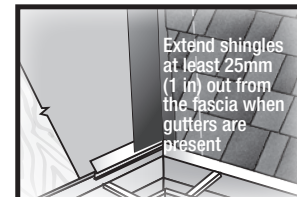
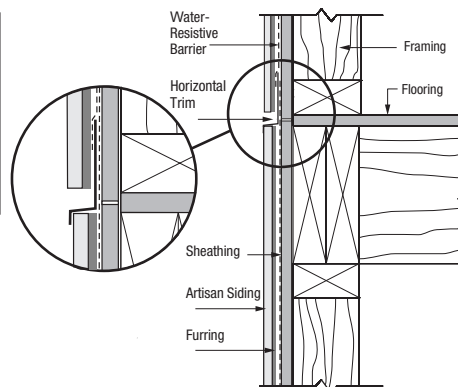

Figure 13  
Bridging Floors



\*James Hardie recommends installing a rainscreen (an air gap) between the Artisan siding and the water-resistive barrier as a best practice.





# ARTISAN SIDING INSTALLED HORIZONTALLY

## JOINT PLACEMENT & TREATMENT

Artisan® siding butt joints shall land a minimum 50mm (2 in) off stud (fig. 14). Do not nail within 50mm (2 in) of the end of planks.

FIGURE 14

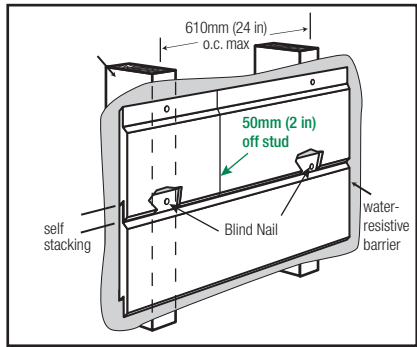

Artisan® siding butt joints can be treated with either Option A caulk\* or Option B by removing minimum 75mm (3 in) of locking lip from both ends of siding then place a joint flashing.

OPTION A:  
CAULKED BUTT JOINT

FIGURE 15A

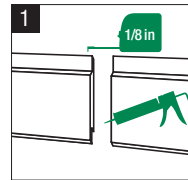

OPTION B:  
JOINT FLASHING

FIGURE 15B

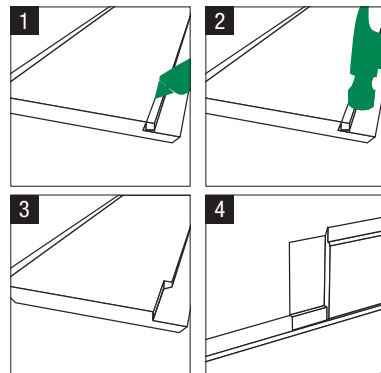

## INSTALLATION/FASTENER REQUIREMENTS

- A. Follow all clearance requirements.
- B. A starter strip is not needed.
- C. Level and install starter course.
  - Tip: Use a small scrap piece of siding to use as a block to seat the siding into the course below.
- D. Artisan siding can now be installed by stacking the siding onto the course below. This can be completed by one person without the need of a lap gauge.
- E. Measure occasionally to ensure siding is level and has proper reveal.
- F. In areas such as gables, under windows, or other areas where stacking may be difficult use one of the following methods
  1. Cut the material in sections, install first section into place. Take remaining section and slide into place, then fasten both sections.
  2. Using a utility knife, cut the bottom lip from the siding and install in the traditional method

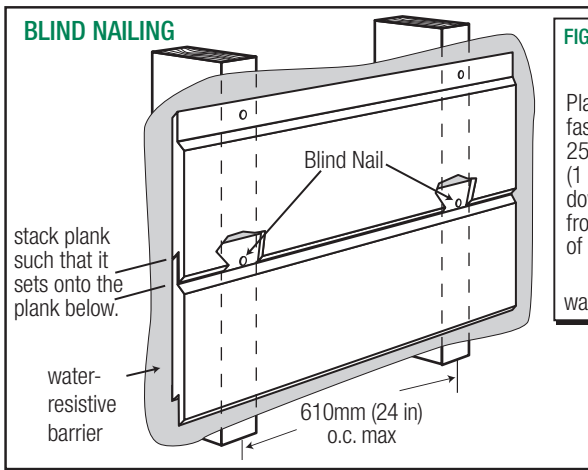

FIGURE 16A

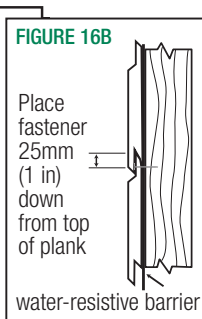

FIGURE 16B

Place fastener 25mm (1 in) down from top of plank

water-resistant barrier

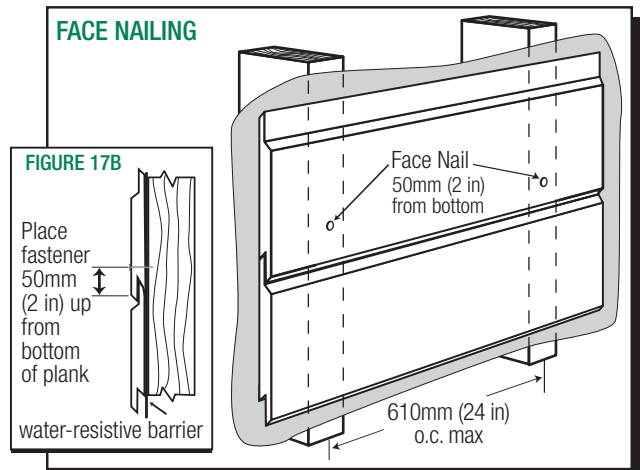

FIGURE 17B

Place fastener 50mm (2 in) up from bottom of plank

water-resistant barrier

FIGURE 17A

For proper fastener selection and fastening schedules for various wind load requirements and framing options, refer to the product Technical Data Sheet at [www.aspyredesign.com](http://www.aspyredesign.com)



\*Caulk joint as required by local building code and leave gap per caulk manufacturers recommendations



## ARTISAN SIDING INSTALLED VERTICALLY

### General Requirements

The vertically installed Artisan siding with Lock Joint System must not bridge over transitions between floors or stories. A horizontal joint must be created between floors, and z-flashing must be provided at each horizontal joint.

Do not create horizontal butt joints between planks. Only use full length pieces for each floor section, except where abutting wall openings and penetrations.

A bead of sealant must be placed along the entire length at each board underlap (see Fig. 19).

- The bead of sealant shall be placed on the underlap of the board about to be installed on the wall.

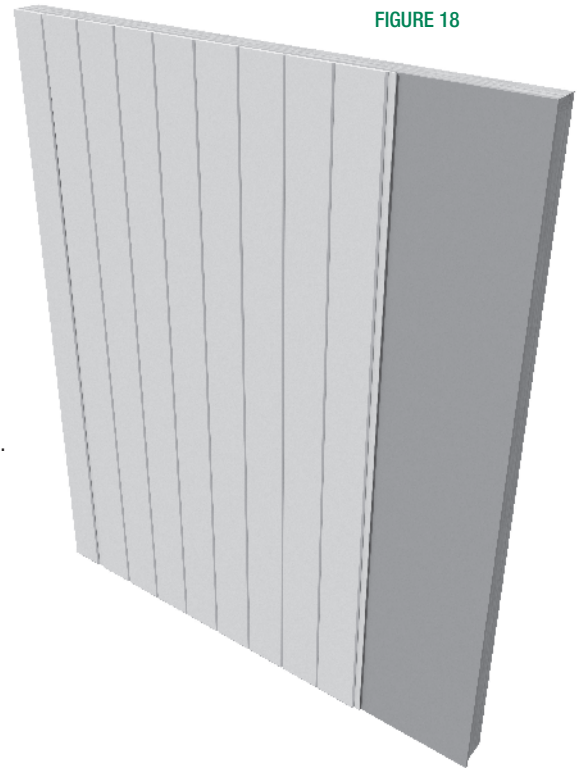
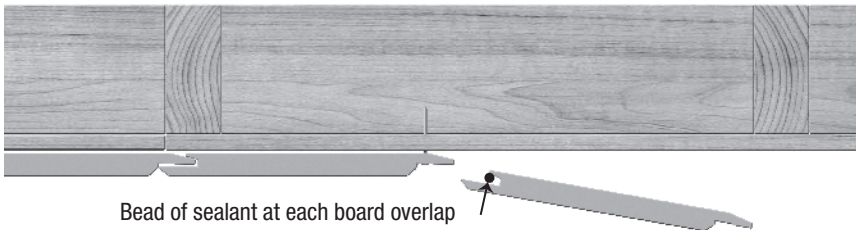

FIGURE 18

FIGURE 19



Bead of sealant at each board overlap

### Direct Fastening to Wood Structural Panel (WSP)

- A minimum 7/16 in WSP, attached per code, is available as the outer most layer directly behind the siding.
- Siding is fastened directly to the minimum 7/16 in WSP over a standard Water Resistant Barrier (WRB) or drainable housewrap.

For proper fastener selection and fastening schedules for various wind load requirements and framing options, refer to the product Technical Data Sheet at [www.aspyredesign.com](http://www.aspyredesign.com)





## ARTISAN SIDING PRODUCTS AS SOFFIT

### INSTALLATION / FASTENER REQUIREMENTS

- Artisan siding with the Lock Joint System may be installed in soffit applications over wood or steel framing spaced a maximum of 610mm (24 in) on center.
- Additional framing may be needed to ensure proper fastening.
- Artisan siding can be installed in the long direction (fig. 22) or the short direction (fig. 23)
- Plan and cut out for any venting requirements prior to installation of Artisan siding.
- Place butt joints between studs (fig. 22). Install butt joints in moderate contact in soffit applications (caulking, H covers, and battens are also acceptable)

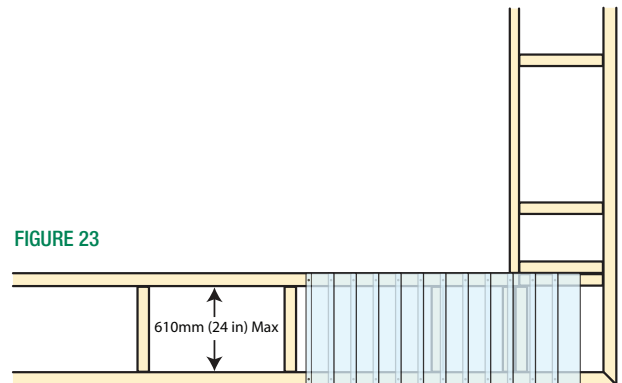
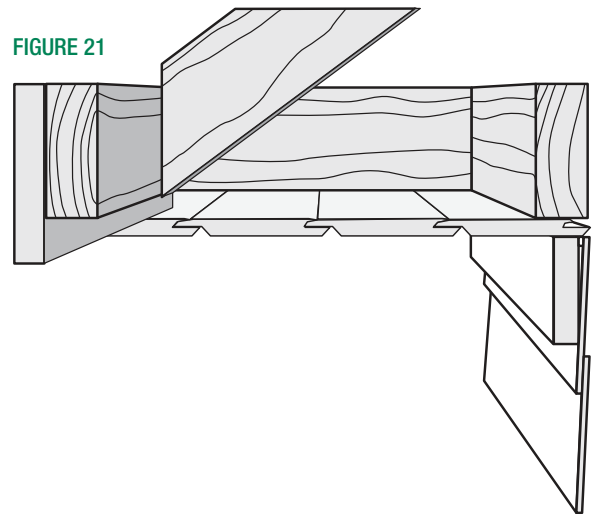

### FASTENER REQUIREMENTS

- **BLIND NAILING:** Place fastener no closer than 25 mm (1 in) from Artisan siding ends and 25 mm (1 in) down from top of Artisan siding.
- **FACE NAILING:** Place fastener no closer than 25 mm (1 in) from Artisan siding ends and 50 mm (2 in) from bottom of Artisan siding.

For proper fastener selection and wind load table, refer to the product Technical Data Sheet at [www.aspyredesign.com](http://www.aspyredesign.com)





## GENERAL FASTENING REQUIREMENTS

Fasteners must be corrosion resistant, galvanized, or stainless steel. Electro-galvanized are acceptable but may exhibit premature corrosion. James Hardie recommends the use of quality, hot-dipped galvanized nails. James Hardie is not responsible for the corrosion resistance of fasteners. Stainless steel fasteners are recommended when installing James Hardie products near the ocean, large bodies of water, or in very humid climates.

Manufacturers of ACQ and CA preservative-treated wood recommend spacer materials or other physical barriers to prevent direct contact of ACQ or CA preservative-treated wood and aluminum products. Fasteners used to attach HardieTrim Tabs to preservative-treated wood shall be of hot dipped zinc-coated galvanized steel or stainless steel.

- Consult applicable product evaluation or listing for correct fasteners type and placement to achieve specified design wind loads.
- NOTE: Published wind loads may not be applicable to all areas where Local Building Codes have specific jurisdiction. Consult James Hardie Technical Services if you are unsure of applicable compliance documentation.
- Drive fasteners perpendicular to siding and framing.
- Fastener heads should fit snug against siding (no air space). (fig. A)
- Do not over-drive nail heads or drive nails at an angle.
- If nail is countersunk, fill nail hole and add a nail. (fig. B)
- For wood framing, under driven nails should be hit flush to the plank with a hammer (For steel framing, remove and replace nail).
- Do not use aluminum fasteners, staples, or clipped head nails.

## PNEUMATIC FASTENING

James Hardie products can be hand nailed or fastened with a pneumatic tool. Pneumatic fastening is highly recommended. Set air pressure so that the fastener is driven snug with the surface of the siding. A flush mount attachment on the pneumatic tool is recommended. This will help control the depth the nail

is driven. If setting the nail depth proves difficult, choose a setting that under drives the nail. (Drive under driven nails snug with a smooth faced hammer - Does not apply for installation to steel framing).

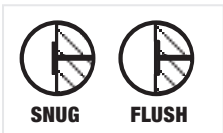

**DO NOT**

**UNDER DRIVE**

---

**IF, THEN**

<b>WOOD FRAME</b>	<b>STEEL FRAME</b>
HAMMER FLUSH	REMOVE & REPLACE

**DO NOT**

**OVER DRIVE**      **SLANT**

---

**IF, THEN ADDITIONAL NAIL**

**FACE NAIL**

COUNTERSINK & FILL

**DO NOT USE**

**ALUMINUM FASTENERS**

**CLIPPED HEAD NAILS**

**STAPLES**

## CAULKING & PAINTING

Elastomeric Joint Sealant is required in accordance with Part 9.27.4 of the NBC, complying with ASTM C920 Grade NS, Class 25 or higher or a Latex Joint Sealant complying with ASTM C834. Caulking/Sealant must be applied in accordance with the caulking/sealant manufacturer's written instructions. **Note: Some caulking manufacturers do not allow tooling.**

DO NOT use stain, oil/alkyd based paint, or powder coating on James Hardie® Products. Factory-primed James Hardie Products must be painted within 180 days of installation. 100% acrylic topcoats are recommended. Do not paint when wet. For application rates refer to paint manufacturer's specifications. Back-rolling is recommended if the paint is sprayed.

## CUT EDGE TREATMENT

Caulk, paint or prime all field cut edges.

## CARE & MAINTENANCE

As a guide, it is recommended that normal maintenance tasks shall include but not be limited to:

- Washing down the exterior surfaces every 6 to 12 months with a garden hose or low pressure water spray to remove dirt and debris.\*
- Re-applying of exterior finishes.\*
- Maintaining the exterior envelope and connections including joints, penetrations, flashings, and sealants (caulking) that may provide a means of moisture entry beyond the exterior cladding.
- Cleaning out gutters, blocked pipes, and overflows as required.
- Pruning back vegetation that is touching the building. Clearance between the siding and shrubs is recommended.
- Ensuring required external ground clearances and drainage slopes are maintained.

## COMPLIANCE:

Artisan siding complies with ASTM Specification C1186 (Grade II, Type A) and ISO Standard 8336 (Category A, Class 2, Level I).

## FIRE-RESISTIVE CONSTRUCTION:

Artisan siding is recognized as a component in 1-hour fire-related wall construction when tested in accordance with CAN/ULC-S101. Details of the listed assemblies may be found at: <https://bpdirectory.intertek.com>



\*Refer to your paint manufacturer for washing and recoating recommendations.



### WARNING

High pressure water blast and sand blasting may damage the surface of the fiber cement product. Low pressure water spray, a soft medium bristle (nonmetal) brush is most suitable for cleaning fiber cement products. Acid washing can damage the fiber cement surface and is not recommended.

Note: If using a pressure washer, care must be taken to ensure that the water stream does not damage the surface of the siding. Damage to siding arising from improper cleaning or maintenance may not be covered by the James Hardie warranty. Using wide fan tips that are kept a minimum of 6 feet from the wall and at pressures under 1500 psi will minimize the chance of damaging the siding.

### COVERAGE CHART / ESTIMATING GUIDE

Number of 12 ft planks, Includes 5% waste factor.

Coverage Area Less Openings 1 SQ = (100 sq ft)	Plank Width Exposure	Plank Width Exposure
	7	9
1	15	12
2	30	24
3	45	35
4	60	46
5	75	59
6	90	70
7	105	82
8	120	94
9	135	105
10	150	117
11	165	129
12	180	140
13	195	152
14	210	164
15	225	175
16	240	187
17	255	199
18	270	210
19	285	222
20	300	234

**SILICA WARNING**

**DANGER:** May cause cancer if dust from product is inhaled. Causes damage to lungs and respiratory system through prolonged or repeated inhalation of dust from product. Refer to the current product Safety Data Sheet before use. The hazard associated with fiber cement arises from crystalline silica present in the dust generated by activities such as cutting, machining, drilling, routing, sawing, crushing, or otherwise abrading fiber cement, and when cleaning up, disposing of or moving the dust. When doing any of these activities in a manner that generates dust you must (1) comply with the OSHA standard for silica dust and/or other applicable law, (2) follow James Hardie cutting instructions to reduce or limit the release of dust; (3) warn others in the area to avoid breathing the dust; (4) when using mechanical saw or high speed cutting tools, work outdoors and use dust collection equipment; and (5) if no other dust controls are available, wear a dust mask or respirator that meets NIOSH requirements (e.g. N-95 dust mask). During clean-up, use a well maintained vacuum and filter appropriate for capturing fine (respirable) dust or use wet clean-up methods - never dry sweep.

**WARNING:** This product can expose you to chemicals including respirable crystalline silica, which is known to the State of California to cause cancer. For more information go to [P65Warnings.ca.gov](http://P65Warnings.ca.gov).

