

SNO-WAY®

SNOW & ICE CONTROL EQUIPMENT

ASSEMBLY & INSTALLATION INSTRUCTIONS

VEHICLE MOUNT KIT 99101201 FOR UTV SERIES PLOW

TO FIT:

2008 & Later - Case IH Scout, Scout XL
2008 & Later - New Holland Rustler 120, 125
2007 & Later - Club Car Carryall 1500, 1500SE, 1550, 1550SE
2007 & Later - Husqvarna HUV 4421, 4421 XL
2007-2010 - Bobcat 2200, 2300, 3400



1. THINK SAFETY, ALWAYS WEAR SAFETY GLASSES WHEN PERFORMING THE OPERATIONS PRESCRIBED IN THESE INSTRUCTIONS
2. READ ALL INSTRUCTIONS CAREFULLY BEFORE ATTEMPTING INSTALLATION
3. BEFORE BEGINNING WORK MAKE SURE TO SET PARKING BRAKE AND CHOCK WHEELS



ASSEMBLY TOOLS NEEDED

Impact Sockets	7/16" - 1-3/8"
Wrenches	7/16" - 1-3/8"
Torque Wrench	
Rat Tail Pry Bar	
Center Punch and Hammer	
C-Clamp	
Screwdrivers	

INSTALLATION NOTES

1. Vehicle should be parked on a level surface with a normal vehicle load on the FRONT suspension.
2. On some vehicles it may be necessary to raise or stiffen the suspension to decrease the vehicles front suspension sag with the snow plow in place.
3. Unless otherwise specified, mount all Vehicle Mount Kit Components to vehicle before tightening any hardware.
4. It is recommended that LOCTITE®, or similar thread locking product, be used on ALL mounting hardware (i.e. Nuts, Cap Screws, Bolts, etc.).
5. Items in parentheses () refer to quantity required for this step. Items in parentheses with a pound sign (#) indicate the part number as found in the parts list on the last page of this document.
Example: (2) 1/2" Lock Washers (#9).

MOUNTING INSTRUCTIONS

1. Remove two lower center cap screws from the grill.

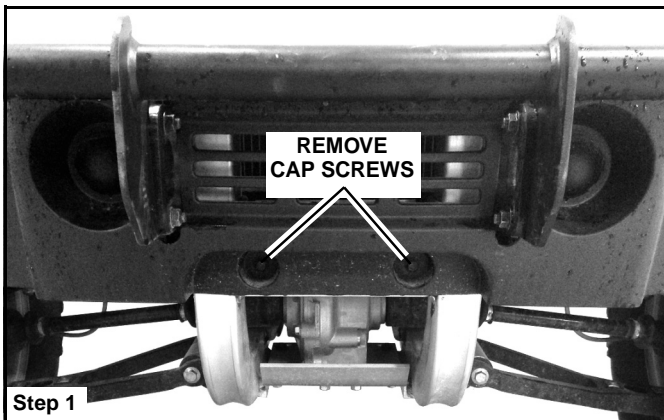

2. Pull the center of the grill forward and insert the Spacer Plate (#4) behind the grill against the frame cross member. Place the Top Plate (#1) behind the grill on top of the Spacer Plate (#4). The holes in the Spacer Plate (#4) and Top Plate (#1) should be lined up with the lower holes in the frame cross member.

NOTE: Spacer Plate (#4) is not needed if the front receiver hitch is installed.

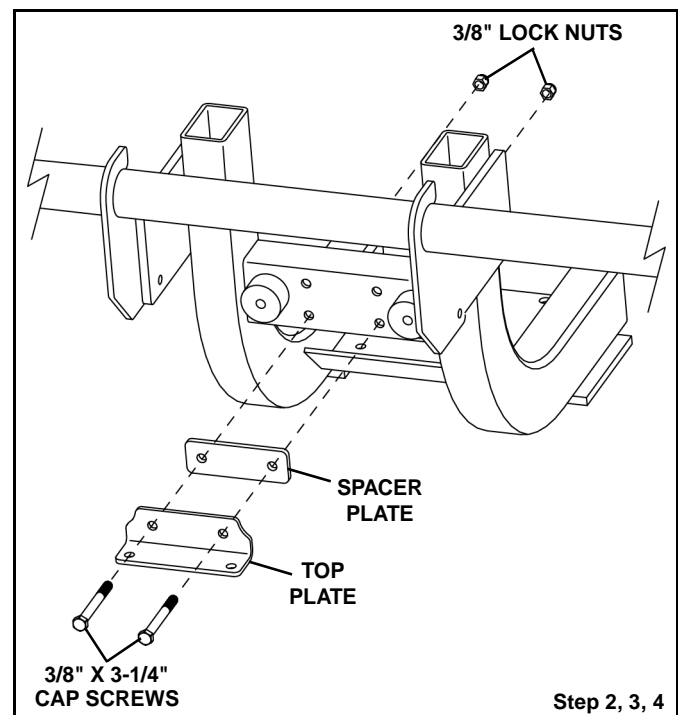

3. Insert (2) 3/8" x 3-1/4" Cap Screws (#10) thru the Top Plate (#1), Spacer Plate (#4), and frame cross member. Secure with (2) 3/8" Lock Nuts (#12).
4. Torque hardware in step 3 using the Torque Specification Chart located in the back of the manual.
5. Replace bumper hardware removed in step 1 and tighten.

- Place the Bottom Bracket (#3) under the front of the UTV. Align the four holes in the Bottom Bracket (#3) with the four holes in the bottom plate of the frame.

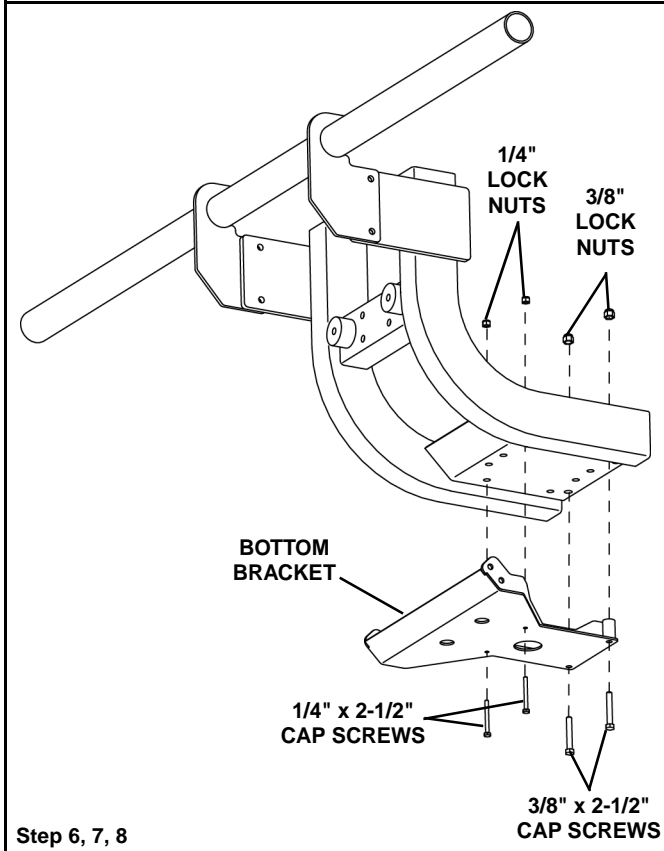

- Insert (2) 1/4" x 2-1/2" Cap Screws (#5) in the front two holes of the Bottom Bracket (#3) and bottom plate of the frame. Secure with (2) 1/4" Lock Nuts (#6).
- Insert (2) 3/8" x 2-1/2" Cap Screws (#9) in the rear two holes of the Bottom Bracket (#3) and bottom plate of the frame. Secure with (2) 3/8" Lock Nuts (#12).

- Remove the lower cap screw from both sides of the bumper.

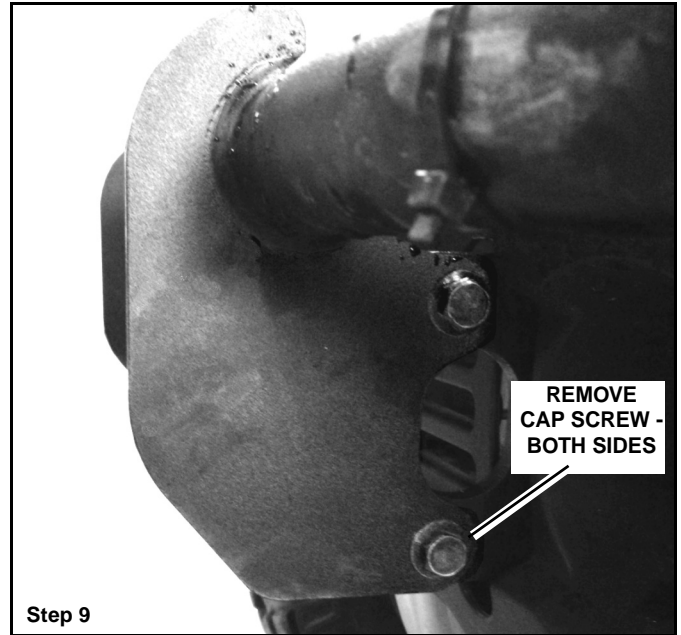

- Place the Top Bracket (#2) on top of the Top Plate (#1). Insert (2) 3/8" x 1-1/4" Cap Screws (#7) thru the Top Bracket (#2) and the Top Plate (#1). Secure with (2) 3/8" Lock Nuts (#12).

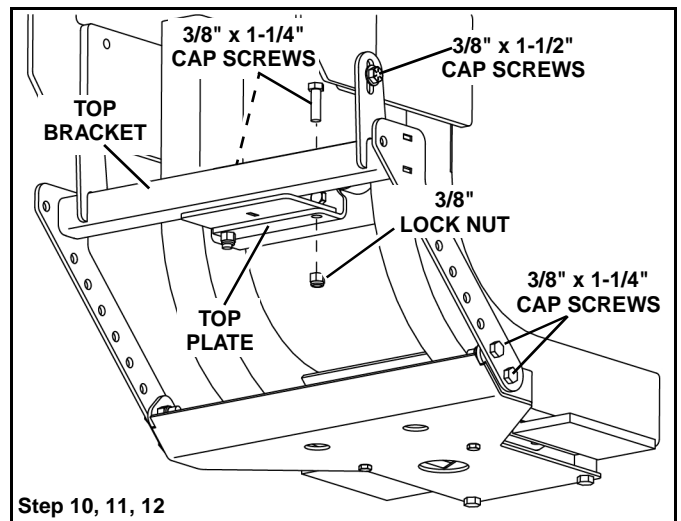

- Insert (2) 3/8" x 1-1/2" Cap Screws (#8) and (2) 3/8" Washers (#11) through the Top Bracket (#2), bumper, and bumper bracket. Secure with (2) 3/8" Lock Nuts (#12).
- Insert (4) 3/8" x 1-1/4" Cap Screws (#7) thru the Top Bracket (#2) and Bottom Bracket (#3). Secure with (4) 3/8" Lock Nuts (#12).

13. Position the UTV Mount (#13) to the outside of the Top Bracket (#3). Adjust the UTV Mount height so that the center of the lower pin slots is 11 to 12 inches off the ground.

IMPORTANT: Height from the bottom of the lower pin slots on the UTV Mount to the ground should be between 11" and 12" to ensure proper operation.

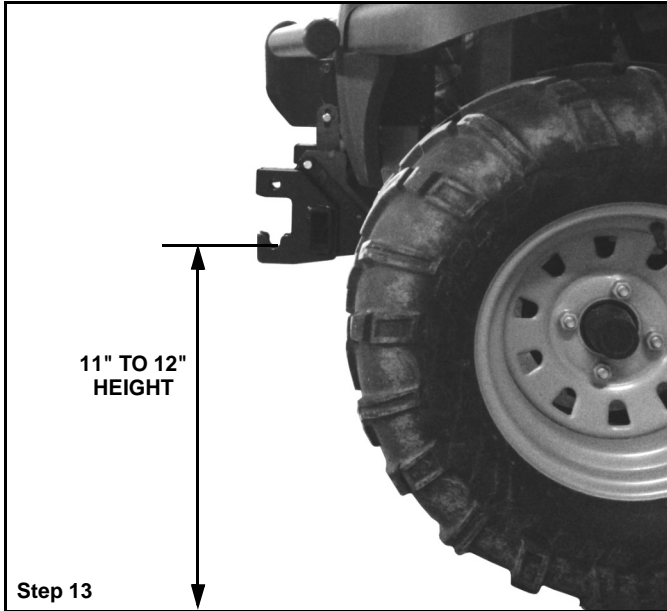

NOTE: The UTV Mount is shipped in the power pack carton.

NOTE: You may need to remove and re-install hardware from step 12 to obtain proper height.

14. Secure the UTV Mount (#13) with (6) 3/8" x 1-1/4" Cap Screws (#7) and (6) 3/8" Lock Nuts (#12).

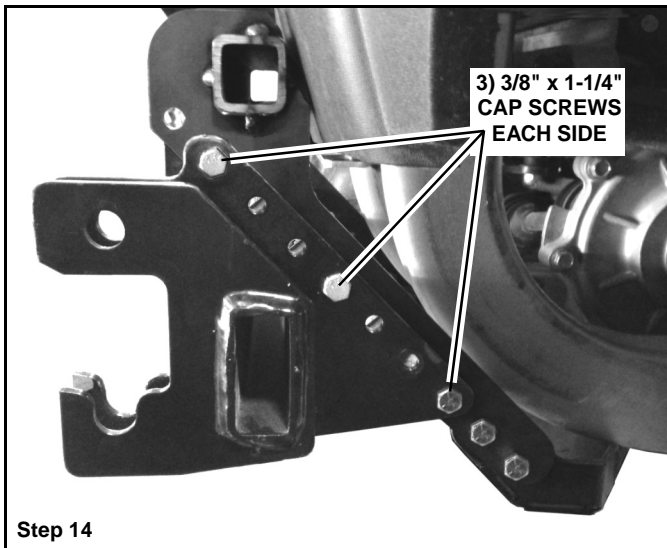

15. Tighten all hardware using the Torque Specification Chart below:

TORQUE SPECIFICATIONS FOR STANDARD MACHINE HARDWARE					
Bolt Size	GR.2 Dry	GR.5 Dry	GR.8 Dry	Metric Size	GR.8.8 Dry
1/4"	66*	9	12	M8	17
5/16"	11	17	25	M10	35
3/8"	20	30	45	M12	60
7/16"	32	50	70	M14	95
1/2"	50	75	110	M16	155
9/16"	70	110	150		
5/8"	100	150	220		
3/4"	175	260	380		
7/8"	170	430	600		
1"	250	640	900		

These torque values are to be used for all hardware. Unless otherwise specified, all torque values must meet this specification.
All torque values are in Ft.-Lbs unless otherwise stated
*In-Lbs

REMEMBER After 5 to 10 hours of snowplow usage, re-torque all hardware!

PARTS LIST

Note: It is recommended that LOCTITE®, or similar thread locking product, be used on ALL mounting hardware (i.e. Nuts, Cap Screws, Bolts, etc.).

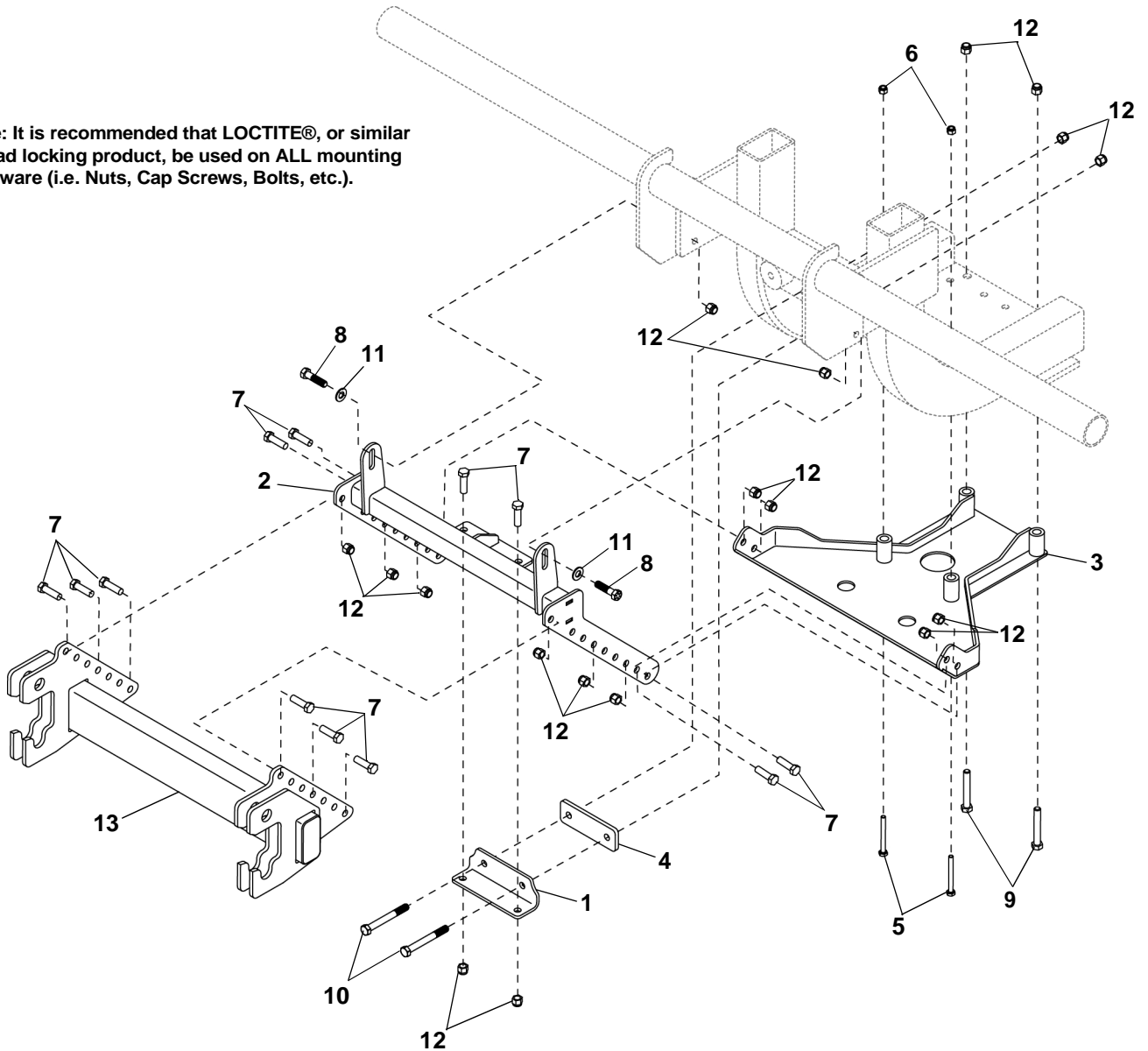

ITEM	PART NO.	DESCRIPTION	QTY.
1		Plate, Top, Case IH Scout.....	1
2		Weldment, Top Bracket, Case IH Scout.....	1
3		Weldment, Bottom Bracket, Case IH Scout.....	1
4		Plate, Spacer, Case IH Scout.....	1
5		HHCS, 1/4"-20 x 2.5".....	2
6		LN, 1/4"-20.....	2
7		HHCS, 3/8"-16 x 1-1/4".....	12
8		HHCS, 3/8"-16 x 1-1/2".....	2
9		HHCS, 3/8"-16 x 2-1/2".....	2
10		HHCS, 3/8"-16 x 3-1/4".....	2
11		PW, 3/8".....	2
12		LN, 3/8"-16.....	18
13		UTV Mount (Inside Power Pack Carton).....	1
14	96115670	Kit, HDWE (Not Shown) (Includes items 5-12).....	1

SNO-WAY® INTERNATIONAL, INC.



Hartford, WI 53027 USA
Website: www.snoway.com
©2015 Sno-Way® International