

ATB Series Multi-Turn Bevel Gear Boxes

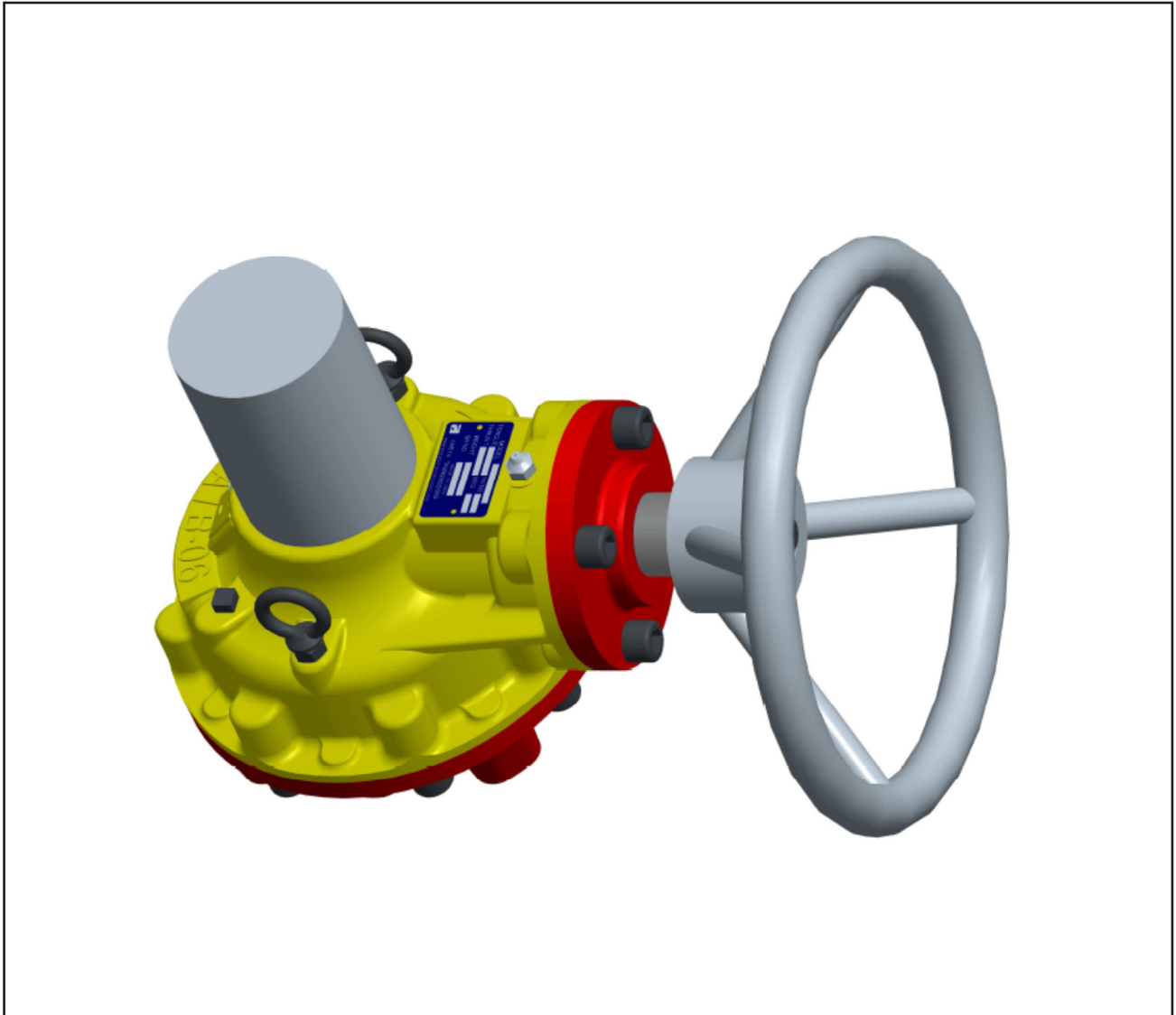

Table of Contents

Section 1: Preface

1.1 Purpose.....	1
------------------	---

Section 2: About the ATB Series

2.1 Introduction.....	2
2.2 The ATB Series Operator.....	2

Section 3: Storage and Preinstallation

3.1 Before Installation	5
-------------------------------	---

Section 4: Installation

4.1 Mounting Types	6
--------------------------	---

Section 5: ATB Series Gearbox Operation

5.1 Manual Use	7
----------------------	---

Section 6: Lubrication

6.1 Application	9
-----------------------	---

Section 7: Disassembly and Reassembly Instructions

7.1 Removal of Base Plate.....	10
7.2 Dismantling of Pinion Assembly	11
7.3 Removal of Adaptor Assembly.....	12
7.4 Removal of Bevel Gear.....	13
7.5 Reassembly of ATB Series Gearbox.....	13

Section 8: Document Revision

Appendix A: List of Figures

Section 1: Preface

1.1 Purpose

Bettis Actuation Technologies is an Emerson Business Unit that specializes in the manufacture of valve actuators and manual operators. Its manual actuation product range consists of five series of valve operators as mentioned below:

- Quarter-turn worm gear operators for manual valve operation (ATB Series)
- Quarter-turn worm gear operators for electrical actuation of valves (EA Series)
- Quarter-turn worm gear manual overrides for pneumatic/hydraulic operation of valves (MOR Series)
- Multi-turn bevel gear operators for manual or electrically actuated valves (ATB Series)
- Quarter-turn worm gear operators with integral worm shaft for manual valve operation (IS Series)

The ATB Series is a selection of full turn bevel gear operators for manual as well as electrically operated valve systems. The ATB Series gear operator is used to operate the valve manually with help of a hand wheel as well as actuator.

The ATB Series gearbox is used to operate a gate valve, globe valve, pinch valve or used in reduction applications. The torque is transmitted through the hand wheel and bevel pinion which in turn, drives the adaptor located in the bevel gear thereby multiplying the torque transmitted from bevel pinion to the bevel gear, which is connected to the valve stem.

The purpose of this IOM is to help the user of this equipment on the following:

- Safety instructions
- Installation of ATB Series gearboxes
- Operation of ATB Series gearboxes
- Maintenance of ATB Series gearboxes

Safety notices in this manual highlight the precautions the user must take in order to avoid personal injury and damage to the equipment. The user must read this manual before attempting to install the equipment or operate or carry out maintenance of the equipment. Failure to follow the instructions mentioned in this manual could result in serious personal injury, equipment damage, operational difficulty and voiding of the warranty.

Bettis Actuation Technologies will not be responsible for any possible damage or physical injury resulting from the use of their equipment other than the designed application or the lack of care taken by the user during installation, operation or maintenance of the equipment. Such risks lie entirely with the user.

Section 2: About the ATB Series

2.1 Introduction

The ATB Series gear operators are full turn bevel gearboxes which are used to operate gate, globe, pinch valves or any other 90-degree operation.

The ATB Series bevel gearbox has one valve mounting face on the bottom side ribbed face and has an adaptor to suit the valve stem directly. The gearbox can be directly mounted onto the valve or it can be coupled with the valve with the help of a bracket .

Below are the different views of the ATB Series gearbox highlighting its different parts as well as instructions.

2.2 The ATB Series Operator

Figure 1 ATB Series General View

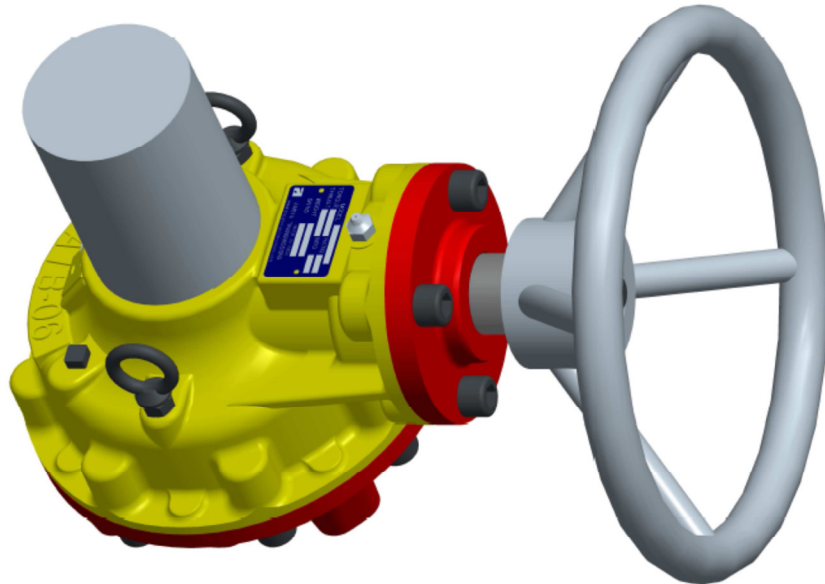

Figure 2 ATB Series Exploded View

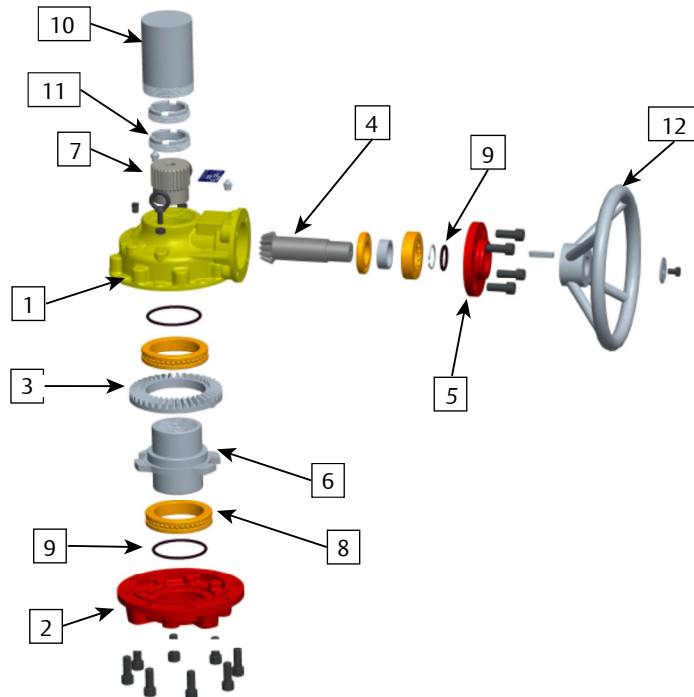
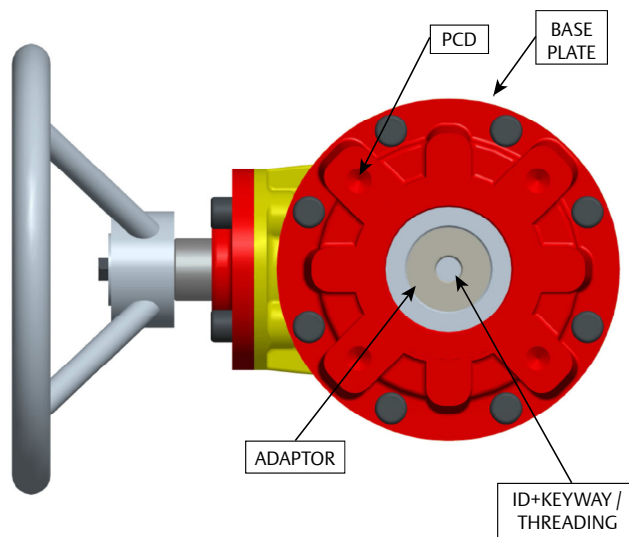

Table 1. Component List

PART NUMBER	PART NAME
1	Housing
2	Base Plate
3	Bevel Gear
4	Bevel Pinion
5	Flange Cap
6	Adaptor Sleeve
7	Adaptor
8	Bearing
9	O-ring
10	Stem Protector Pie
11	Slotted Lock Nut
12	Handwheel

Figure 3 ATB Series Bottom View



Section 3: Storage and Preinstallation

3.1 Before Installation

1. Firstly, check whether the ATB Series gearbox received is not in damaged condition during transportation.
2. Also, check whether the data on the nameplate corresponds to the expected product data.
3. If the ATB Series gearbox is to be stored indoors for a brief period (less than 12 months), it should be ensured that the gearbox is kept in a dry place, preferably on a wooden pallet and protected from dust.
4. If the ATB Series gearbox is to be stored outdoors for a brief period (less than 12 months), it should be protected from coming in direct contact with rain with a canvas or something similar. Also, it should be kept on a wooden pallet or a raised platform to avoid direct contact with the ground and protected from dust.
5. If the ATB Series gearbox is to be stored for a longer period (more than 12 months), then the mating surfaces, couplings, exposed parts, etc. should be coated with a protective oil or grease to avoid corrosion.

Section 4: Installation

4.1 Mounting Types

The ATB Series gearbox can be installed onto the valve in two different ways:

1. **DIRECT MOUNTING** -- This involves mounting the gearbox directly on the valve stem and valve mounting flange.
2. **BRACKET MOUNTING** – This involves installing the bracket on the valve flange. The ATB Series Gearbox is mounted on the bracket.

Following procedure should be followed while installation of ATB Series gearboxes onto valve systems:

1. First, couple the valve stem with the adaptor of the gearbox either by threading or with keyway. Ensure sufficient grease is used for lubrication between valve stem and adaptor. Then slide down the valve stem with gear box assembly and fix the other end of the valve stem to the valve.
2. For rising spindle valves the threading of the valve stem should be such that “clockwise rotation of hand wheel gives clockwise rotation of output to close the valve”.
3. Check whether the mounting dimensions (stem diameter/threading and mounting PCD) between valve and the bevel gearbox are correct and as per the requirement.
4. The mounting flange of valve and bevel gearbox should be degreased.
5. Mount the bevel gearbox such that the spigot on mounting flange of bevel gear box locates in the counter bore of mounting flange of valve or bracket. Never use the hand wheel or spur gear attachment to lift the gearbox while mounting onto the valve. Use the eye bolts instead for lifting the gear box.
6. Fasten the mounting bolts with the help of spring washers. Use 8.8 grade fasteners or above.
7. In case of reinstallation after a long storage period, check the status of oil seals, O-rings and also whether the gearbox body/cover are cracked or broken.
8. In case of electrically operated valves the actuator mounting flange of bevel gear box & mounting flange of actuator should be degreased.
9. Check whether the mounting dimensions (shaft diameter and mounting PCD) of bevel gear box and actuator are as per the requirement.
10. Mount the actuator on the actuator mounting flange of the bevel gear box and fasten the mounting bolts with the help of spring washers. Use 8.8 grade fasteners as above.

Section 5: ATB Series Gearbox Operation

5.1 Manual Use

1. The bevel gearbox is to be operated with a hand wheel which is supplied along with the gearbox or electric actuator which is supplied separately.
2. Do not manually operate the gearbox with devices other than the hand wheel. Using cheater bars, wheel wrenches or other such devices on the gearbox hand wheel may cause serious injury and/or damage to the gearbox or valve.
3. In standard applications, “clockwise rotation of hand wheel gives clockwise rotation of output to close the valve”.

Figure 4 Hand Wheel Rotation

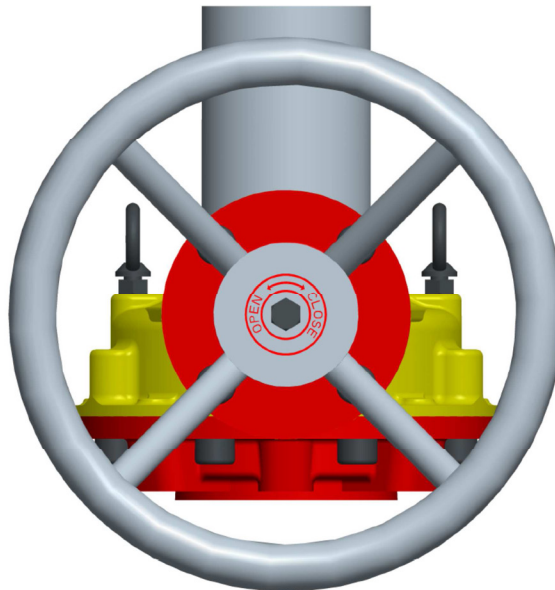
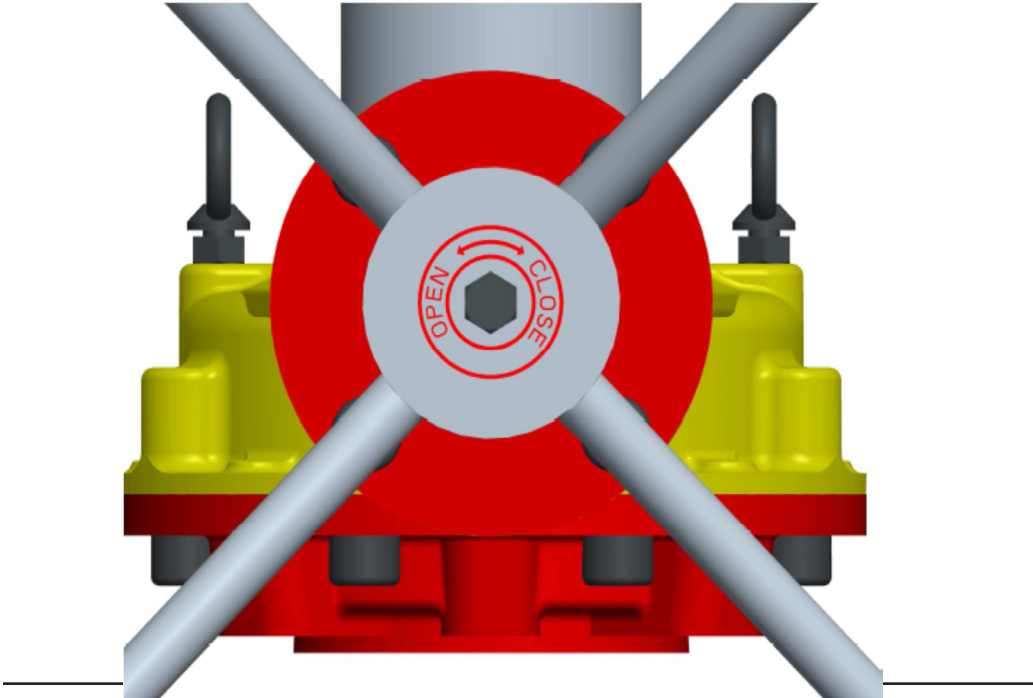

Figure 5 Another View of the Hand Wheel Rotation



Section 6: Lubrication

6.1 Application

1. The ATB Series gearbox is grease lubricated.
2. All ATB Series gearboxes are supplied with EP-1 premium quality lithium soap based grease (NLGI grade 1) suitable for an ambient temperature of -20° C to +120° C (in case of specialty greases, the temperature range could be different).
3. Grease should be changed after 6 months if the gearbox is in continuous operation whereas it should be changed after 12 months if it is operated intermittently.
4. Do not mix different greases.

Section 7: Disassembly and Reassembly Instructions

7.1 Removal of Base Plate

- Remove the base plate by loosening the cover bolts with a spanner.
- Each time the base plate is removed, the gasket sealing is lost as it is a liquid sealant. Reapply gasket sealant (Loctite no. 596 or equivalent).
- Take proper care not to damage the mating surface of the base plate with the housing.

Figure 6 Base Plate Removal

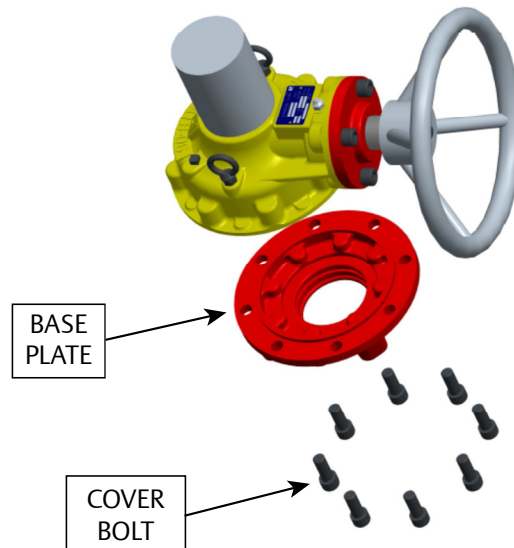

7.2 Dismantling of Pinion Assembly

- Remove the hand wheel and open close label and key by loosening the hand wheel bolt with a spanner.
- Remove the Flange cap/actuator mounting flange by loosening the mounting bolts with a spanner.
- Pull the bevel pinion out of the main housing. This will disassemble the entire bevel pinion line assembly. Now remove all other small parts like spacers, bearings, O-rings, circlips etc. from this assembly.

Figure 7 Removal of Pinion (Manual Operation)

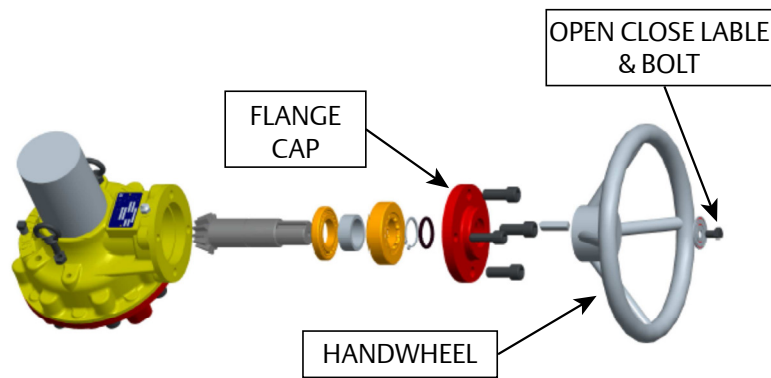
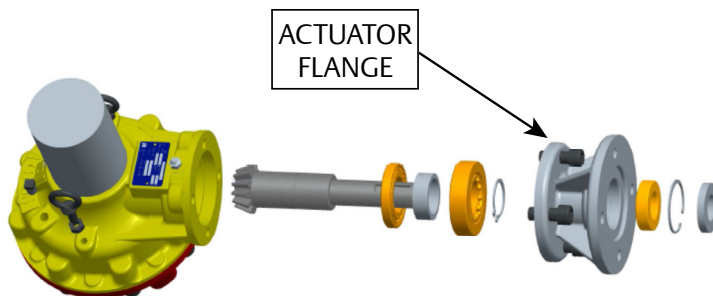

Figure 8 Removal of Pinion (Electrical Actuation)



7.3 Removal of Adaptor Assembly

- Remove the stem protector pipe by loosening the grub screw which is fitted with housing and stem protector pipe.
- Remove slotted lock nut with the help of spanners.
- Remove adaptor which is inserted in adaptor sleeve.

Figure 9 Removing the Adaptor

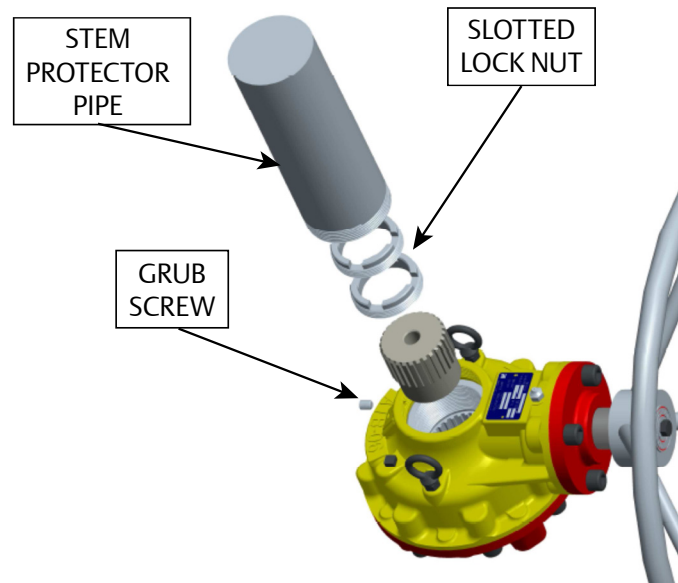

7.4 Removal of Bevel Gear

- Remove the base plate (step 1).
- Remove adaptor (step 3).
- Remove bearing and adaptor sleeve.
- Remove bevel gear by lifting it from the gearbox housing.
- Replace the O-rings and lubricate the gear in the housing before reassembling the bevel gear.

Figure 10 Removing the Bevel Gear

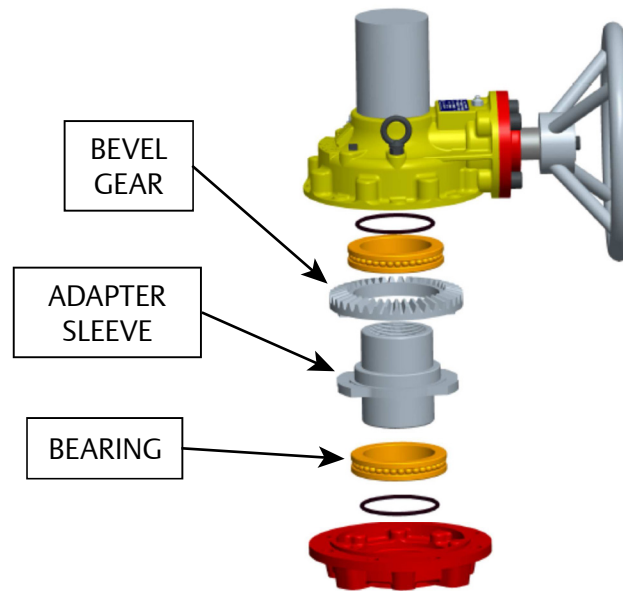

7.5 Reassembly of ATB Series Gearbox

- In reassembly of the ATB Series gearbox, follow all above steps in reverse order.
- Be sure to lubricate all mating/rotating parts with grease.
- Ensure to provide a liquid sealant on both covers and housing.

Section 8: Document Revision

Table 2. Revision Overview

ECN	DATE	REVISION	STATUS	BY *	DATE
XXXXXX	7/15/2016	1	Completed	Charles Rico	7/15/2016

* Signatures on file Bettis, Houston, Texas

Appendix A: List of Figures

Figure 1	ATB Series General View	2
Figure 2	ATB Series Exploded View	3
Figure 3	ATB Series Bottom View	4
Figure 4	Hand Wheel Rotation	7
Figure 5	Another View of the Hand Wheel Rotation	8
Figure 6	Base Plate Removal.....	10
Figure 7	Removal of Pinion (Manual Operation).....	11
Figure 8	Removal of Pinion (Electric Actuation)	11
Figure 9	Removing the Adaptor	12
Figure 10	Removing the Bevel Gear.....	13

World Area Configuration Centers (WACC) offer sales support, service, inventory and commissioning to our global customers. Choose the WACC or sales office nearest you:

NORTH & SOUTH AMERICA

19200 Northwest Freeway
Houston TX 77065
USA
T +1 281 477 4100

Av. Hollingsworth
325 Iporanga Sorocaba
SP 18087-105
Brazil
T +55 15 3413 8888

ASIA PACIFIC

No. 9 Gul Road
#01-02 Singapore 629361
T +65 6777 8211

No. 1 Lai Yuan Road
Wuqing Development Area
Tianjin 301700
P. R. China
T +86 22 8212 3300

MIDDLE EAST & AFRICA

P. O. Box 17033
Jebel Ali Free Zone
Dubai
T +971 4 811 8100

P. O. Box 10305
Jubail 31961
Saudi Arabia
T +966 3 340 8650

24 Angus Crescent
Longmeadow Business Estate East
P.O. Box 6908 Greenstone
1616 Modderfontein Extension 5
South Africa
T +27 11 451 3700

EUROPE

Holland Fasor 6
Székesfehérvár 8000
Hungary
T +36 22 53 09 50

Strada Biffi 165
29017 Fiorenzuola d'Arda (PC)
Italy
T +39 0523 944 411

For complete list of sales and manufacturing sites, please visit www.emerson.com/actuationtechnologieslocations or contact us at info.actuationtechnologies@emerson.com

www.emerson.com/bettis

©2018 Emerson. All rights reserved.

The Emerson logo is a trademark and service mark of Emerson Electric Co. Bettis™ is a mark of one of the Emerson family of companies. All other marks are property of their respective owners.

The contents of this publication are presented for information purposes only, and while every effort has been made to ensure their accuracy, they are not to be construed as warranties or guarantees, express or implied, regarding the products or services described herein or their use or applicability. All sales are governed by our terms and conditions, which are available on request. We reserve the right to modify or improve the designs or specifications of our products at any time without notice.

BETTIS™

