

AVANT[®]

Attachments



Foreword

This catalogue contains most of the Avant attachments available from Avant Tecno Oy at the date of printing.

Avant has a policy of continuing product development and retains the right to change specifications without notice.

All attachments listed in this catalogue may not be available in all markets and countries, please consult your local Avant dealer.

Operation of certain attachments may require specific equipment on the loader. Please consult your local Avant dealer.

Compatibility tables between attachments and loader models are advisory. All attachments do not fit on all loader models. Please contact your local Avant dealer to make sure that the attachment is compatible with your Avant loader.

Table of Contents

Buckets, material handling.....	4-16	Property maintenance.....	17-35
General bucket.....	4	Dozer blade 1400.....	17
Light material bucket.....	5	Dozer blade 2000.....	18
4 in 1 bucket.....	6	Dozer blade 2500.....	19
High tip bucket.....	7	Snow plow.....	20
XL high tip bucket.....	8	Snow blade.....	21
Grapple bucket.....	9	V-Snow blade.....	22
Demolition grapple bucket.....	9	Flipper bucket.....	23
Levelling bucket.....	10	Snow blower.....	24
Pallet fork.....	11	Rotary Broom.....	25
Pallet fork with side shift.....	12	Collecting broom.....	26
Skip bucket.....	13	Bucket broom.....	27
Jib boom.....	14	Sand/salt spreader.....	28
Telescoping jib boom.....	15	Centrifugal sand / salt spreader.....	29
Ball hitch on front.....	16	Towable sand / salt spreader.....	30
		Vacuum brush.....	31
		Leguan 50 Access platform.....	32
		Tipping trailer.....	33
		Trailer/Timber trailer.....	34
		High pressure washer.....	35

Table of Contents

Ground care.....	36-44	Farming.....	65-79
Lawn mower 1200.....	36	Silage fork.....	65
Lawn mower 1500.....	37	XL silage grab.....	66
Collecting lawn mower 1200.....	38	Feeding table cleaning blade.....	67
Collecting lawn mower 1500.....	39	Silage dispenser bucket.....	68
Flail mower.....	40	Feed mover screw.....	69
Cutting bar.....	41	Silage block cutter.....	70
Fingerbar mower with hydraulic boom..	42	Carousel broom.....	71
Flail mower with hydraulic boom.....	43	Bale fork.....	72
Edge trimmer.....	44	Round bale grab.....	73
Landscaping.....	45-54	Square bale grab.....	74
Rotary hoe.....	45	Manure fork.....	74
Stone burier.....	46	Straw blower bucket.....	75
Rotary harrow.....	47	Grain/flour dispenser bucket.....	75
Leveller.....	48	Push broom.....	76
Ripper.....	49	Horse arena harrow.....	77
Screening bucket.....	50	Big bag transporter.....	78
Stump buster.....	51	Stone collecting bucket.....	79
Stone grab.....	52	Power Packs.....	80
Stone installation clamp.....	53	Pressure washer.....	80
Grabbing tool.....	54	Compressor.....	80
Digging and construction.....	55-64	Forestry.....	81-86
Backhoe 210.....	55	Log grab.....	81
Backhoe 260.....	56	Log grab, heavy duty.....	81
Mini digger.....	57	Tree shear.....	82
Trencher.....	58	Winch.....	82
Auger.....	59	Log splitter.....	83
Hydraulic breaker.....	60	Log cutter/splitter.....	84
Cutter crusher.....	61	Firewood machine.....	85
Concrete mixing bucket.....	62	Wood chipper CH100.....	85
Drum type concrete mixer.....	63	Wood chipper CH150 heavy duty.....	86
Vibrating plate.....	64	Options.....	87-89
Asphalt grinder.....	64	Tilt adapter.....	87
		Receiver hitch.....	88
		Attachment control switch pack.....	88
		Adapter plate.....	89
		Skid-Steer Attachment Mounting Adapters..	89



General bucket

Avant general buckets are designed so that the operator can see the front edge of the bucket from the driver's seat, allowing for quick and easy loading and emptying.

Length of the bucket has been optimized in order to give the best possible breakout force.

There is a grill at the upper end of the bucket which prevents stones from falling towards the operator.

- **General purpose bucket, suitable for almost every shovelling job**
- **Excellent visibility to the edge of the bucket**
- **High breakout force**

Buckets with straight edge

Width	Struck Capacity	Heaped Capacity	Weight	Product no
35.0 in	6.6 cu ft	7.7 cu ft	126 lb	BER-BKG35
42.0 in	7.9 cu ft	9.2 cu ft	173 lb	BER-BKG42
44.0 in	8.3 cu ft	9.7 cu ft	179 lb	BER-BKG44
50.0 in	9.4 cu ft	11.0 cu ft	203 lb	BER-BKG50
55.0 in	10.4 cu ft	12.1 cu ft	220 lb	BER-BKG55
65.0 in	12.3 cu ft	14.3 cu ft	233 lb	BER-BKG65

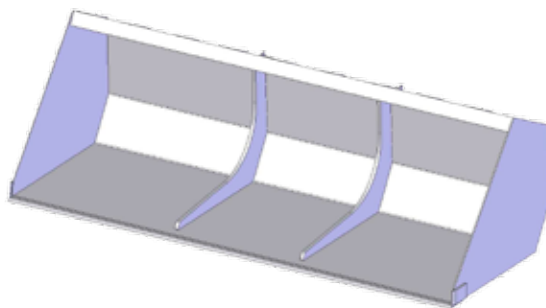

Buckets with teeth

Width	Struck Capacity	Heaped Capacity	Weight	Product no
41.3 in	7.4 cu ft	9.9 cu ft	165 lb	A33242
43.3 in	7.6 cu ft	10.1 cu ft	187 lb	A21500
50.4 in	9.2 cu ft	12.2 cu ft	198 lb	A21167
55.1 in	10.1 cu ft	13.4 cu ft	209 lb	A21205

419	420	520	528	630	635	640	745	750

Very compatible
 Compatible
 Incompatible



Light material bucket

Light material buckets are intended for handling of snow, saw dust, manure, wood chips and other light materials.

The bottom of a light material bucket is considerably longer and the sides are higher than a general bucket.

- Fast and easy moving of light materials
- Excellent visibility to the edge of the bucket
- High back of the bucket prevents material from falling over the rear edge and carries high volume

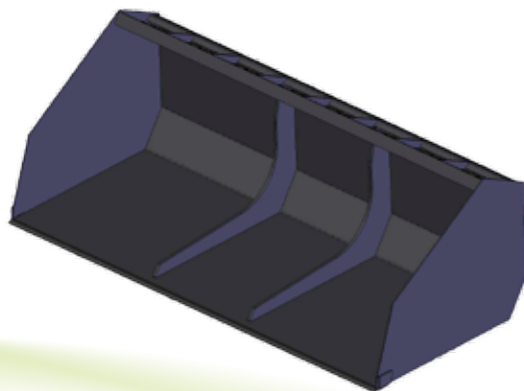

400, 500, 600 and 700 series

Width	Struck Capacity	Heaped Capacity	Weight	Product no
42.0 in	14.6 cu ft	18.3 cu ft	262 lb	BER-BKL42
44.0 in	15.3 cu ft	19.1 cu ft	269 lb	BER-BKL44
50.0 in	17.4 cu ft	21.7 cu ft	290 lb	BER-BKL50
63.0 in	21.9 cu ft	27.4 cu ft	335 lb	BER-BKL63
70.0 in	24.7 cu ft	30.8 cu ft	378 lb	BER-BKL70

419	420	520	528	630	635	640	745	750



Very compatible



Compatible



Incompatible



4 in 1 bucket

Multi-purpose bucket that can be used as a normal bucket as well as a dozer blade, leveler or a grab. The front part of the bucket opens with 2 hydraulic cylinders, located on the back side of the bucket, which enables dozing, levelling and picking of stones, tree stumps etc. Another benefit of the opening bottom is that the bucket can be emptied at a higher level by opening the bottom instead of tipping the bucket edge down.

Available with straight edge or with teeth.

- **All around tool for landscaping and ground care**
- **A versatile bucket suitable for many different jobs at different stages on the work site**



400, 500, 600 and 700 series

Edge	Width	Volume	Weight	Product no
straight	43.3 in	5.5 cu ft	335 lb	A21245
straight	50.4 in	6.0 cu ft	386 lb	A21156
straight	55.1 in	7.4 cu ft	419 lb	A21266
teeth	43.3 in	5.5 cu ft	357 lb	A21249
teeth	50.4 in	6.0 cu ft	408 lb	A21184
teeth	55.1 in	7.4 cu ft	445 lb	A21269

419	420	520	528	630	635	640	745	750

Very compatible
 Compatible
 Incompatible



High tip bucket

High tip bucket is the right choice when you need to reach higher and longer. The bucket is equipped with a hydraulic cylinder that pushes and tips the bucket over its front edge, which gives considerably more tipping height than with a normal bucket.

Maximum tipping height with telescopic boom on 400, 500 and 600 series 124" and on 700 series as high as 138".

- **High tipping height**
- **More volume than on general bucket – excellent for loose and light material loading**



400, 500, 600 and 700 series

Width	Volume	Weight	Product no
41.3 in	5.3 cu ft	284 lb	A2631
50.4 in	12.4 cu ft	353 lb	A2824

419	420	520	528	630	635	640	745	750



Very compatible



Compatible



Incompatible



XL high tip bucket

The XL high tip bucket has more loading volume - very useful when loading light materials. The bucket is an ideal tool for snow removal, loading of wood chips and for loading works on recycling plants etc.

Tipping of the bucket happens with two hydraulic cylinders – this means emptying is also easy with full load in the bucket.

- Large volume bucket for efficient loading of light materials
- Tipping height as high as 138”

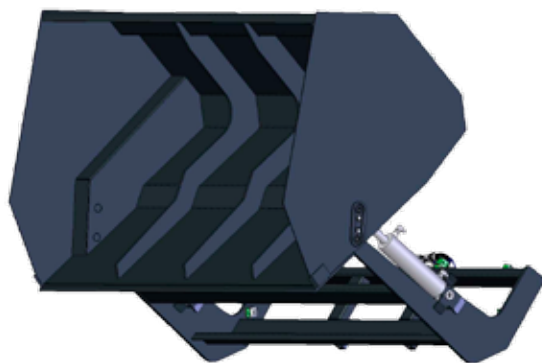

500, 600 and 700 series

Width	Volume	Weight	Product no
70.9 in	32 cu ft	730 lb	A21273

419	420	520	528	630	635	640	745	750

Grapple bucket

The Grapple bucket combines a normal bucket and a grapple and is therefore suitable for a multitude of jobs. It can be used for transporting and loading of branches, wood chips, compost, straw, manure, construction waste etc. It can also be used as a normal bucket with the grapple in the upright position.



- Versatile bucket for handling of loose materials

Buckets, material handling

400, 500, 600 and 700 series

Width	Weight	Product no
35.4 in	287 lb	A32484
41.3 in	320 lb	A32448
51.2 in	364 lb	A33639

419	420	520	528	630	635	640	745	750

Very compatible
 Compatible
 Incompatible

Demolition grapple bucket

The demolition grapple bucket with two hydraulic grapples is a strong and versatile attachment for handling of construction and demolition waste.



- Versatile bucket with two hydraulic grapples, for demolition and construction

400, 500, 600 and 700 series

Width	Weight	Product no
43.3 in	400 lb	A36045
51.2 in	435 lb	A36031

419	420	520	528	630	635	640	745	750

Very compatible
 Compatible
 Incompatible



Levelling bucket

Avant levelling buckets are built with heavy duty construction in mind. The sharp back edge of the bucket makes levelling easy when driving backward. Other features include a longer bottom, which enables the driver to see the tip of the bucket perfectly and this also makes leveling easier.

- **Excellent visibility to tip of bucket**
- **Sharp back edge enables exact levelling when driving backward**
- **Heavy duty design**

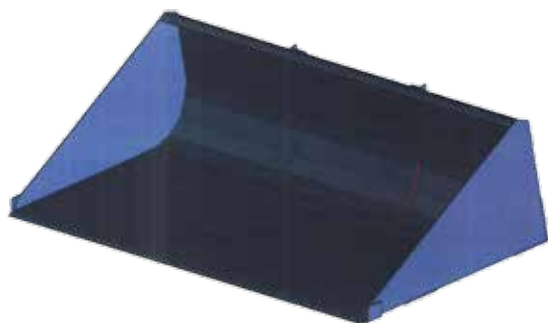

500, 600 and 700 series

Width	Volume	Weight	Product no
50.4 in	7.1 cu ft	375 lb	A21504
55.1 in	8.5 cu ft	397 lb	A21505

419	420	520	528	630	635	640	745	750



Pallet fork

Avant pallet fork is the right attachment for lifting and handling of different types of materials on pallets. Fork width can easily be adjusted thanks to the quick lock mechanism. The forks are made of high tensile forged steel.

Avant is an excellent machine for load handling thanks to the precise steering and drive control. Compared with a conventional forklift truck, Avant is superior when working outdoors and on terrains, be it winter or summer.

- **Excellent field of vision both to the attachment and to the environment makes working with pallet forks precise and easy**
- **Pallet fork is a useful attachment for all material handling jobs**



400, 500, 600 and 700 series

Fork length	Weight	Product no
30.0 in	154 lb	CAPF30
36.0 in	174 lb	CAPF36
42.0 in	194 lb	CAPF42
45.0 in	204 lb	CAPF45
48.0 in	214 lb	CAPF48

419	420	520	528	630	635	640	745	750



Very compatible



Compatible



Incompatible



Pallet fork with side shift

Hydraulic fork adjustment on the pallet fork makes it possible to move the forks further apart or closer to each other easily and comfortably from the driver's seat. The forks can also be moved to the left or to the right, making it possible to shift the load to the side of the machine - closer to a wall for example. All functions can be operated from the driver's seat. Pallet fork is equipped as standard with a foldable back frame which enables handling of larger loads and protects the driver from falling objects.

- **Hydraulic side shift and fork width adjustment**
- **Foldable back frame as standard**



500, 600 and 700 series

Fork length	Weight	Product no
43.3 in	381 lb	A21474

The optional attachment control switch pack A34700 is recommended on the loader.

419	420	520	528	630	635	640	745	750



Skip bucket

Avant skip bucket is a very useful attachment for waste collecting, transporting, storing and emptying. The bucket tilts down so that one can load it from ground level, and thanks to the sharp front edge, filling is easy and efficient. The bucket has two support legs so that it can be left standing in place while you are doing other work with the machine.

- **Replace the waste bins on the site with the skip bucket**
- **Loading, transporting and emptying of the bucket is very easy with Avant**



400, 500, 600 and 700 series

Width	Volume	Weight	Product no
37.4 in	12.7 cu ft	265 lb	A2838
54.7 in	24.7 cu ft	353 lb	A21126

419	420	520	528	630	635	640	745	750



Very compatible



Compatible



Incompatible



Jib boom

Avant jib boom is a simple and ingenious attachment: lifting and moving heavier loads in tight situations are not a problem any more when you have this jib boom on your Avant.

The maximum lifting height is 13' (height of the lifting hook).

- **Economical attachment, suitable for many different lifting jobs**
- **Connecting points on the boom increase lifting safety**



400, 500, 600 and 700 series

Lift hooks	Length	Weight	Product no
2 pcs	47.2 in	66 lb	A32395

419	420	520	528	630	635	640	745	750



Telescoping jib boom

The hydraulic telescoping jib boom is a very efficient and versatile tool in all lifting jobs on the work site. The steplessly extending and retracting boom allows lifting to places that would otherwise be very hard to reach. Compact design with telescoping cylinder inside the boom makes work safe and easy.

The jib boom is equipped with a rotating lifting hook and durable wear pads on the outer boom.

- **Excellent outreach, as much as 120" from the front wheels**
- **Max. lift height with 700 series as high as 187"**
- **Versatile lifting attachment for various load handling jobs**

500, 600 and 700 series

Max. boom length	74.8 in
Min. boom length	51.2 in
Lifting height*	185 in
Max load Avant 700 ser*	880 lb
Max load Avant 600 ser*	660 lb
Max load Avant 500 ser*	550 lb
Max. outreach*	120 in
Weight	243 lb
Product no	A21342

* Both the telescopic boom of the loader and the jib boom extended to max. outreach.

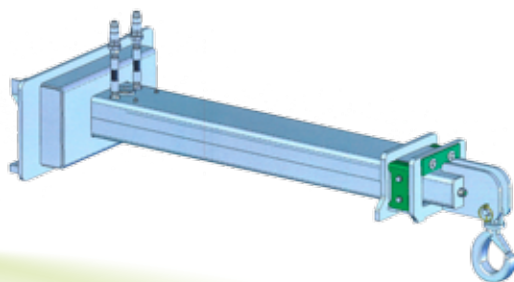

419	420	520	528	630	635	640	745	750



Very compatible



Compatible



Incompatible



Ball hitch on front

The ball hitch on front allow for an easier way to move trailers or trailer mounted work platforms. Thanks to the perfect vision of the ball hitch, it is very easy to couple a trailer by just driving the ball under the trailer and locking it in the coupling by lifting the boom of the loader.

Equipped with both a ball hitch and a towing pin.

300, 400, 500, 600 and 700 series

Weight	Product no
75 lb	A35592

419	420	520	528	630	635	640	745	750



Dozer blade I400

Equipped with hydraulic blade turning, Avant dozer blade is the ideal tool for snow removal, earthmoving and similar jobs where the materials must be dozed away quickly. The blade is equipped with spring release mechanism which protects the blade and driver in case it hits an obstacle.

Rubber blade and ice cutting blade available as option.

- Economical dozer blade, well suited for snow removal
- Spring release mechanism for improved safety



Options:

Extensions 2 x 7" (can be mounted straight or in collecting position)
A48869, Ice cutting blade A32315, Rubber blade A32383

400, 500, 600 and 700 series

Working width	55 in
Weight	229 lb
Angle	$\pm 30^\circ$
Blade height	15 in
Product no	A2867

419	420	520	528	630	635	640	745	750



Very compatible



Compatible



Incompatible



Dozer blade 2000

Equipped with hydraulic blade turning, Avant dozer blade is the ideal tool for snow removal, earthmoving and similar jobs where the materials must be dozed away quickly. The blade is equipped with spring release mechanism which protects the blade and driver in case it hits an obstacle.

Dozer blade 2000 is equipped with a higher blade than the 55" dozer blade which means that you can move bigger amounts of snow, gravel etc. with it. Dozer blade 2000 is equipped with two bolt-on extensions, 10" each which can be mounted as collecting or straight edge. Equipped with a turnable blade with straight and ice cutting edge.

- Two solid support legs which reduce blade wear and improve maneuverability
- Robust construction and higher blade than on Dozer blade 1400 for more efficient dozing
- Versatile dozer blade, efficient on larger areas but still compact enough for tight situations as well
- Turnable 2 x 10" extensions as standard, can be mounted in collection position or straight
- Equipped with a turnable blade with straight / ice cutting edge



Options: Rubber blade 78.7" A33833

400, 500, 600 and 700 series

Working width	78.7 in
Weight	364 lb
Angle	± 30 °
Blade height	19.7 in
Product no	A2944

419	420	520	528	630	635	640	745	750

Very compatible
 Compatible
 Incompatible



Dozer blade 2500

Equipped with hydraulic blade turning, Avant dozer blade is the ideal tool for snow removal, earthmoving and similar jobs where the materials must be dozed away quickly. The blade is equipped with spring release mechanism which protects the blade and driver in case it hits an obstacle.

Dozer blade 2500 is ideally designed for clearing snow from large areas, such as large industrial estates, parking lots etc. Dozer blade 2500 is equipped with two bolt-on extensions, 10" each which can be mounted as collecting or straight edge. Equipped with a turnable blade with straight and ice cutting edge.

- Robust construction and higher blade than on Dozer blade 2000, with spring release mechanism
- Recommended for snow removal on larger areas
- Turnable 2 x 10" extensions as standard, can be mounted in collection position or straight
- Equipped with a turnable blade with straight / ice cutting edge



400, 500, 600 and 700 series

Working width	98.4 in
Weight	573 lb
Angle	± 30 °
Blade height	20.5 in
Product no	A410365

Options: Rubber blade 98.4" A35624

419	420	520	528	630	635	640	745	750



Very compatible



Compatible



Incompatible



Snow plow

Avant snow plow is a versatile attachment for snow removal. It consists of two independent hydraulically adjustable blades. Both blades have a spring release mechanism in the lower part of the blade which protects the blade and driver incase it hits an obstacle. The float mechanism on the mounting bracket guarantees that the blade follows ground as well as possible.

Angle of both blades can be adjusted independently with a toggle switch from the driver's seat.

- **Versatile snow removal tool for professional use**

400, 500, 600 and 700 series

Model	1800	2200
Blade width	70.9 -59.1 in	86.6 -70.9 in
Blade turning angle	± 35°	± 35°
Weight	617 lb	672 lb
Blade height	30.3 in	30.3 in
Product no	A21048	A34368

Requires attachment control switch pack A34700 on the loader



Options:
Support legs with skid shoes for models 1800 and 2200 A417068

419	420	520	528	630	635	640	745	750

Very compatible
 Compatible
 Incompatible



V-Snow blade

Avant V-Snow Blade is a versatile attachment for snow removal. With hydraulic valve function for independent blade functions, V, Scoop, left, right and straight position. Angling up to 30° in both directions, reversible cutting edge design with spring loaded Trip mechanism. Blade Floats 5° and tilts 5° for ground contour.

• **Note: Blade type must be ordered with unit**

400, 500, 600 and 700 series

Model	50	60
Height	32.5 in	32.5 in
Width	50 in	60 in
Full V	47 in	56 in
Full Scoop	39.5 in	48.0 in
Cutting Width Max Angle 30 degree	43.5 in	52.0 in
Product no	PLV5047	PLV6056
Poly blade	PB50	PB60
Metal blade	MB50	MB60

419	420	520	528	630	635	640	745	750

Very compatible
 Compatible
 Incompatible



Snow blade

Avant snow blade is designed for fast snow clearing in large areas. The snow blade is especially good at clearing road areas from snow, because the snow is thrown further away in a single pass. The form of the snow blade is designed so that snow picks up against the back wall of the snow blade creating a twirl on the snow. When the snow is in motion, it moves easier to the side of the snow blade creating less force that moves the machine sideways and the snow is also thrown further away. The plastic middle part makes the blade light and allows snow to glide easier to the side of the blade, which also helps to throw the snow further away.

- **Fast way to clear snow from large areas and roads**
- **Throws snow further away in a single pass than a regular dozer blade**
- **Creates less sideways force, so the front of the loader will not move so easily to the side**

600 and 700 series

Blade width	86.6 in
Wing width	98.4 in
Turning angle	$\pm 30^\circ$
Weight	827 lb
Product no	A21493

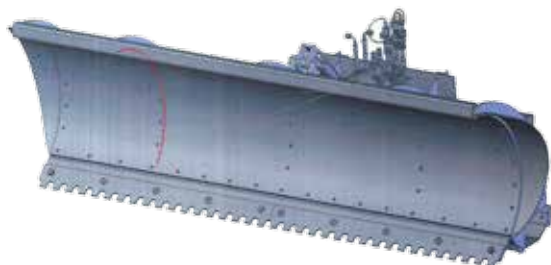

Options: Rubber blade A21497

419	420	520	528	630	635	640	745	750





Flipper bucket

Flipper bucket is designed for clearing snow in large areas or in areas where snow must be moved long distances. Thanks to the independently controllable side wings, the bucket is especially good at clearing roads and can be operated in smaller areas as well without problems.

With the flipper bucket, you can move a large quantity of snow in one push. Because the wings fold out slightly forward from the sides, you can push 2-3 times the capacity of the bucket between the wings. Both wings can be operated independently. This makes the bucket easy to control also in narrow or tight areas.

- **Large volume bucket, 26 cu ft**
- **Independently controllable side wings**
- **Max. working width over 118"**



600 and 700 series

Volume	26 cu ft
Width	70.9 - 118.5 in
Weight	720 lb
Product no	A414035

The optional attachment control switch pack A34700 is recommended on the loader.

419	420	520	528	630	635	640	745	750

Very compatible
 Compatible
 Incompatible



Snow blower

Avant two-stage snow blower is an efficient attachment for snow removal from sidewalks, foot paths, roads and similar places. Discharge chute rotation and throwing height can be adjusted electro/hydraulically from the operators seat.

- **Efficient two-stage snow blowers**

400, 500, 600 and 700 series

Cutting Width	Cutting Height	Weight	Product no
48 in	25 in	745 lb	PLSB48AH
48 in	25 in	750 lb	PLSB48DH
60 in	25 in	795 lb	PLSB60DH

The optional attachment control switch pack A34700 is required on the loader.

Model	419	420	520	528	630	635	640	745	750
PLSB48AH	Very compatible	Very compatible	Very compatible	Very compatible	Very compatible	Incompatible	Incompatible	Incompatible	Incompatible
PLSB48DH	Incompatible	Incompatible	Incompatible	Incompatible	Incompatible	Very compatible	Very compatible	Very compatible	Very compatible
PLSB60DH	Incompatible	Incompatible	Incompatible	Incompatible	Incompatible	Very compatible	Very compatible	Very compatible	Very compatible

Very compatible
 Compatible
 Incompatible



Rotary Broom

With three working models available, 1100, 1500 and 2000. The 1500 and 2000 brooms are equipped as standard with power angling by electric actuator motor. This means angling of the broom is easily and comfortably operated with a switch from the driver's seat.

With a floating mechanism the brush is resting on its bristles and the whole brush axle is floating freely. The broom is equipped with supports which can be extended when the broom is not in use, so that the broom rests on the supports and the nylon brush doesn't get damaged during storage.



Option: Electric turning for rotary broom 1100, product no. A36112

Model	419	420	520	528	630	635	640	745	750
1100									
1500									
2000									



Very compatible



Compatible



Incompatible

400, 500, 600 and 700 series

Model	1100	1500	2000
Broom width	43.3 in	59.0 in	79.0 in
Total width	53.9 in	70 in	90 in
Boom diameter	21.7 in	21.7 in	21.7 in
Turning	manual	electric	
Turning angle	+/- 25 °	+/- 25 °	+/- 25 °
Weight	375 lb	440 lb	575 lb
Product no	A36067	A35284	A35583

If the broom is equipped with hydraulic slewing the optional attachment control switch pack A34700 is recommended on the loader.



Collecting broom

A collecting brush for professional property management customers, cities and municipalities. The new brush has a heavy duty construction, floating brush axle, automatic brush wear compensation and a specially designed water spraying system for dust binding.

Enclosed construction all around the main brush provides better collection result when turning and less dust formation.



Option:
 Side brush A35698
 Water spraying system A35642

500, 600 and 700 series

Model	1500
Broom width	59.0 in
Total width	70.0 in
Boom diameter	21.7 in
Box emptying	Hydraulic (with two cylinders)
Box volume	7.1 cu ft
Water tank volume	40 gal
Weight without side brush	935 lb (without water spraying system)
Weight with 1 side brush	990 lb
Weight with 2 side brush	1050 lb

Product no	Side brush	water spraying system
A35602	no	no
A35918	1 brush	no
A35919	1 brush	yes

The optional attachment control switch pack A34700 is recommended on the loader.

419	420	520	528	630	635	640	745	750

Very compatible
 Compatible
 Incompatible



Bucket broom

Bucket broom which collects the waste in a large bucket shaped box. The broom gives best sweeping result when reversing, but it also works when driving forward. Forward sweeping is especially recommended when the waste is larger in dimensions, for instance construction waste, beverage cups, tree leaves etc.

The bucket broom is equipped with a floating mechanism which allows the bucket lip to rest against ground freely. This means that the loader must not necessarily be equipped with boom floating when working with the bucket broom. Emptying of the collector happens by first lifting the broom up hydraulically, after that the collector box can be emptied by tilting it down like a normal bucket. Brush axle is equipped with a simple quick locking system for adjusting the sweeping height.

Water spraying system for dust binding is also available. It minimizes dust build up when brushing dry waste.

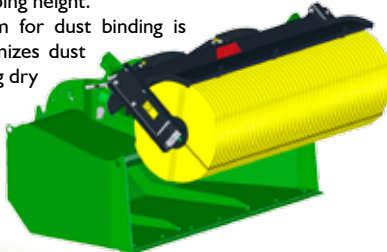

- Sweep driving forward or backwards
- Suitable for collecting larger waste as well
- Large bucket shaped collector box
- Quick, hydraulic emptying

400, 500, 600 and 700 series

Model	1100	1500
Broom width	43.3 in	59.1 in
Total width	53.4 in	69.4 in
Box volume	13.1 cu ft	17.7 cu ft
Boom diameter	19.7 in	19.7 in
Water tank volume	31.7 gal	31.7 gal
Product no	A35945	A35689
Product no. with water spraying system	A36023	A36024

Option:
 A35956 Water spraying system for Bucket broom 1100
 A35807 Water spraying system for Bucket broom 1500

Model	419	420	520	528	630	635	640	745	750
1100									
1500									

Very compatible
 Compatible
 Incompatible



Sand/salt spreader

The hydraulic sand / salt spreaders are designed for fast and efficient spreading. Front mounting allows loading from ground level in the same way as with normal bucket. Powered by hydraulic motor and equipped with a mixer axle which breaks any frozen sand and prevents the sand from clogging up. The plates in the feeding roll are spring loaded so that stones will not block or break the spreader.

- Filling can also be done by loading with the spreader like with a normal bucket
- Robust design

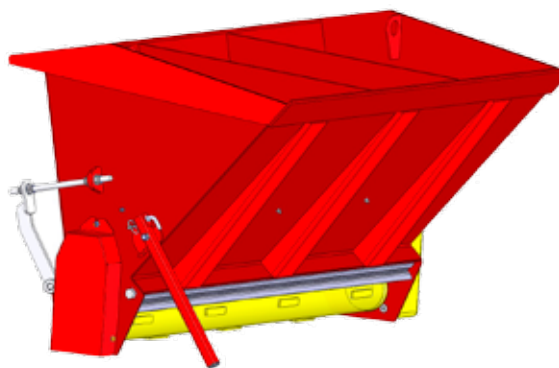

400, 500, 600 and 700 series

Model	900	1500
Spreading width	35.4 in	59.1 in
Volume	7.1 cu ft	17.7 cu ft
Weight	265 lb	595 lb
Operation	Hydraulic	Hydraulic
Product no	A2947	A411401

Model	419	420	520	528	630	635	640	745	750
900									
1500									

Very compatible
 Compatible
 Incompatible



Centrifugal sand / salt spreader

Centrifugal sand or salt spreader is the right choice for winter maintenance of large areas. Spreading area can be adjusted from 6 to 20 feet which guarantees fast and efficient spreading. The spreading amount can be adjusted quickly and easily from the side of the attachment.

- **Fast spreading on large areas**



400, 500, 600 and 700 series

Spreading width	31-240 in
Volume	8.8 cu ft
Max. load	1100 lb
Weight	287 lb
Product no	A21183

419	420	520	528	630	635	640	745	750



Very compatible



Compatible



Incompatible



Towable sand / salt spreader

The towable sand / salt spreader is a very handy and economical attachment for winter maintenance of yards and walkways. Power to the spreader shaft is taken mechanically from the wheels. Wheels are equipped with a clutch which allows transporting without sand spreading. Equipped with a 50 mm trailer coupling.

ATTENTION! The loader must be equipped with a trailer coupling (A31417 or A2952)

- **Economical spreader, quick to attach on the trailer coupling**
- **Mechanical power take off from the wheels – no need for rear auxiliary hydraulics**
- **Includes a durable rain cover to protect from moisture and spillage**



400, 500, 600 and 700 series

Spreading width	39.4 in
Width	59.1 in
Volume	8.1 cu ft
Weight	121 lb
Operation	Mechanical
Product no	A415430

419	420	520	528	630	635	640	745	750

Very compatible
 Compatible
 Incompatible



Vacuum brush

The vacuum brush is intended mainly for collecting of tree leaves in parks, lawns, yards etc. The powerful vacuum unit sucks the waste first into the vacuum on the bottom of the collector box and then into the box, compacting everything into a tight package. The mouthpiece on the vacuum unit has a brush that loosens compacted and wet leaves and waste. Brush rotation speed can be adjusted steplessly.

The collector box is mounted on top of the vacuum unit and it has large windows so that you can easily monitor how the box is filling up. The box is emptied by opening the front lid from Avant's driver seat and with the help of Avant's boom the collected waste can be dumped into a container, skip etc.



- Equipped with Optifloat™ system
- Can be emptied from Avant's driver seat

600 and 700 series

Width without side brooms	47.2 in
Collector box volume	28.0 cu ft
Weight	728 lb
Product no	A34714

The optional attachment control switch pack A34700 is recommended on the loader.

419	420	520	528	630	635	640	745	750

Very compatible
 Compatible
 Incompatible



Leguan 50 access platform

The access platform is mounted directly into Avant loaders quick attach plate. The result is an inexpensive, handy and easy to use access platform. With the help of this lift Avant's versatility is further increased on the job sites.

The Leguan 50 is mounted directly on to Avants quick attach plate like any other Avant attachment. This makes it fast and easy to mount it on and take it off.

The lift is designed according to all access platform directives and it is CE-certified. The safe working load for the lift is 440 lb which means it is allowed for operation with two men or one man with plenty of tools.



- An inexpensive access platform with 197" working height
- Safe and legal way to do building repairs, painting, light bulb changes etc.
- The maximum allowed load on the basket is 440 lb and you are able to use the lift alone
- Leguan 50 is attached to Avant which makes it easy to set it up in virtually all kinds of terrains
- The Leguan 50 access platform gives even further possibilities to use your Avant on work sites

400, 500, 600 and 700 series

Max. allowed load	440 lb
Max. working height	197 in
Height (with lowered platform)	74.8 in
Width	51.2 in
Weight	893 lb
Product no	A34812

419	420	520	528	630	635	640	745	750



Very compatible



Compatible



Incompatible



Tipping trailer

Avant tipping trailer is available in two models: with carrying capacity of 2650 lb or 4000 lb. Both are equipped with hydraulic tipping. All sides can be removed if necessary. Extra side set is available as an option for the smaller model, on the bigger model it is standard.

ATTENTION! The loader must be equipped with the double acting rear auxiliary hydraulics outlet and trailer coupling.

- **Robust and versatile tipping trailers, well suited both for earthmoving and for lighter jobs**
- **All sides can be removed if necessary – giving a completely flat and even bed**
- **Hydraulic tipping on both models**

400, 500, 600 and 700 series

Model	1200	1800
Max. Load	2650 lb	4000 lb
Width	44.3 in	53.1 in
Length	67.3 in	88.2 in
Tire size	23 x 8.5 - 12	26 x 12 - 12
Side height	11.0 in	22.0 in
Product no	A2949	A21200



Option: Extra side set (A45193) for 1200 model

419	420	520	528	630	635	640	745	750



Very compatible



Compatible



Incompatible



Trailer / timber trailer

Avant trailer with manual tipping is useful when transporting garden waste, topsoil, mulch etc. In addition, all sides can be removed if necessary, which makes the trailer an excellent timber transporting vehicle. Big wheels guarantee it will travel on wet ground as well. Equipped with a rotating trailer coupling. Both single and tandem axle versions available.

- **Versatile – can be used both as a normal and timber trailer**



400, 500, 600 and 700 series

Model	Single axle	Double axle
Own weight	220 lb	285 lb
Total weight	1100 lb	1850 lb
Floor size	25.6 x 68.9 in	
Total width	47.2 in	
Product no	A21110	A21111

419	420	520	528	630	635	640	745	750



High pressure washer

This efficient hydraulic washer is fitted with a 71 gal water tank. Maximum water pressure is 2900 PSI, water use is adjustable. Equipped with an adjustable 8 nozzle bar for street washing. A hand held washing gun with 65 foot hose roll is standard equipment as well. The pressure washer makes your Avant a moving washing unit – you can wash your loader, equipment, car etc. easily and efficiently.

- **Efficient high pressure washer, designed for street cleaning**
- **Equipped with a hand held wand**



400, 500, 600 and 700 series

Max. water pressure	2900 PSI
Water consumption	1.3 - 8.0 gal/min
Water container volume	71 gal
Nozzles	8 pcs
Product no	A21009

419	420	520	528	630	635	640	745	750

Very compatible
 Compatible
 Incompatible



Lawn mower 1200

Lawn mower 1200 has a professional frame and transmission design which makes it a strong cutting unit that will keep running for years. The cutting unit is equipped with two blades which provide excellent cutting power.

Lawn mower 1200 can be transformed to side discharging, mulching or rear ejecting type. All necessary parts are included as standard in the mower package. Cutting height can be adjusted with 0.4" spacers on each wheel. Four large rubber support wheels guarantee that mower deck follows the ground well.

- **Powerful mower**
- **Can be transformed to side discharging, mulching or rear ejecting type. All necessary parts are included as standard**
- **Equipped with a floating system to work on uneven ground**

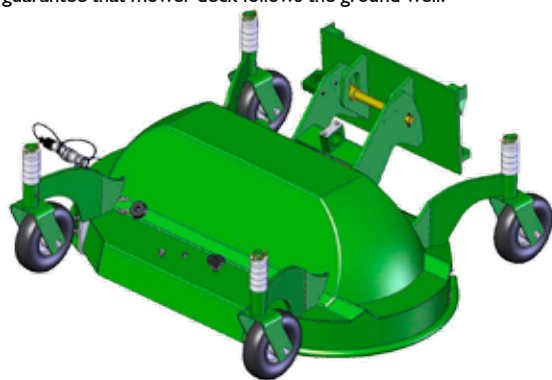

400, 500, 600 and 700 series

Cutting width	47.2 in
Blades	2 pcs
Cutting height	1.0 - 4.0 in
Weight	375 lb
Product no	A21046

419	420	520	528	630	635	640	745	750

Very compatible
 Compatible
 Incompatible



Lawn mower 1500

Avant's biggest lawn mower is intended for professional lawn mowing also on larger areas. The mower can be modified to the right type of mowing for different circumstances.

Powerful mower allows a higher drive speed and perfect cut also on challenging conditions.

Optifloat™ system ensures that the cutting is easy and that the cutting deck follows the ground contours also on uneven terrains. The floating system is also equipped with a safety valve, which stops the blades when the mower is lifted off the ground.



Optional extras: Mulching kit (complete assembly kit) A34530

419	420	520	528	630	635	640	745	750

- **Equipped with Optifloat™ system**
- **More cutting power for challenging mowing conditions**
- **Side discharge as standard, mulching kit available as an option**
- **Rounded edge design reduces damage to trees, buildings etc. in case of contact**

600 and 700 series

Cutting width	59.0 in
Blades	3 pcs
Cutting height	1.0 - 4.0 in
Height	17.7 in
Weight	485 lb
Product no	A34528



Very compatible



Compatible



Incompatible



Collecting lawn mower I 200

With the Avant collecting mower 1200 you can easily mow and collect the clippings. Thanks to its excellent suction power, collecting of leaves from the lawns is also possible.

The mulching blades of the mower crush the grass clippings, leaves etc. into a very fine material which then moves to the collector and forms a tight and compact package. The cutting waste is ideal material for composting. Collector capacity is as big as 55.5 gal, which enables cutting of small to medium sized areas. Emptying of the collector is very easy: open the lid, lift the mower up from the ground with Avant's boom and then tilt the mower forward so that the waste comes out.

- **Powerful cutter with a collector unit**
- **Can also be used for collecting tree leaves on lawns**
- **Vacuum fan can be turned off and mower can be used as side discharging type**

400, 500, 600 and 700 series

Cutting width	47.2 in
Blades	2 pcs
Cutting height	1.0 - 4.0 in
Collector box volume	7.4 cu ft
Product no	A21316



419	420	520	528	630	635	640	745	750



Collecting lawn mower 1500

Collecting mower designed for professional use with 59" cutting width and 210 gal collector box. The high suction power makes it possible to collect tree leaves on lawns. The blades cut the grass, tree leaves etc. to a fine mulch which packs tightly into the collector box.

Collector box volume is designed to be large enough for professional use also in larger areas. The box is emptied from Avant's driver seat with an electric switch and with the help of Avant's boom the collector can be emptied into a container.

- Equipped with Optifloat™ system
- More cutting power for challenging mowing conditions
- Vacuum fan can be turned off and mower can be used as side discharging type
- Rounded edge design reduces damage to trees, buildings etc. in case of contact



600 and 700 series

Cutting width	59.0 in
Height	43.3 in
Blades	3 pcs
Cutting height	1.0 - 4.0 in
Collector box volume	28.0 cu ft
Product no	A34495

The optional attachment control switch pack A34700 is recommended on the loader.

419	420	520	528	630	635	640	745	750



Very compatible



Compatible



Incompatible



Flail mower

Flail mower is a drum-type cutter, intended for cutting of long grass, scrub, bush and similar vegetation. It will cut up to 0.8" thick tree branches with ease.

The blades on the flail mower shaft move freely, so in case they hit a solid obstacle they will give in rather than break. This saves the blades costs when cutting in an unfamiliar place.

Flail mower is the optimal cutting device for places where you need a lot of cutting power and a rougher cut will do. The most common grounds for flail mowers are places with taller vegetation like meadows, road banks, yard areas.

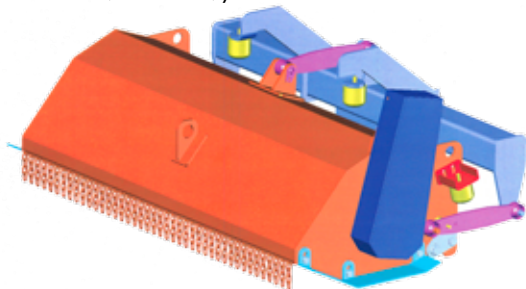

Optional extras: Side shift arm 16 in. right side only. A32355

Model	419	420	520	528	630	635	640	745	750
1100									
1300									
1500									



Very compatible



Compatible



Incompatible

- Vertifloat™ floating system
- More cutting power through unique blade configuration

400 and 500 series

Cutting width	43.3 in
Cutting height	1.0 - 4.0 in
Blades	60 pcs
Weight	575 lb
Product no	A21386
Product no 200 series	A21387

600 and 700 series

Cutting width	51.2 in	59.1 in
Cutting height	1.2 - 4.0 in	
Blades	68 pcs	42 pcs
Weight	485 lb	695 lb
Product no	A21364	A21362



Cutting bar

A simple cutting bar for cutting hay, grass and trimming bushes or vegetative fencing. Can be used as side cutting version but also possible to mount as front cutting version. Cutting angle can be adjusted manually with the hand winch, electric cutting angle adjustment is available as an option.



400, 500, 600 and 700 series

Cutting width	57.1 in
Transport width	100 in
Transport height	70.0 in
Weight	220 lb
Product no	A35676

Optional extras: Electric cutting angle adjustment A35975

419	420	520	528	630	635	640	745	750



Very compatible



Compatible



Incompatible



Fingerbar mower with hydraulic boom

Versatile attachment for hedge cutting, long hay mowing etc. The hydraulically operated boom gives excellent outreach, and it can be extended to both sides of the machine. Strong fingerbar type cutting head can cut maximum 1" branches.

- Versatile attachment for hedge cutting and hay mowing



400, 500, 600 and 700 series

Outreach	138 in
Cutting width	47.2 in
Weight	495 lb
Product no	A411395

419	420	520	528	630	635	640	745	750



Very compatible



Compatible



Incompatible



Flail mower with hydraulic boom

The flail mower with hydraulic boom can reach to places where it is not possible to drive with the machine. This makes mowing of road banks, ditches, waterfronts and other hard-to-reach areas safe and easy. The mower is equipped with proportional controls and joystick for smooth and exact movements of the boom and the mower deck.

It is recommended that the Avant is equipped with a cab (L, LX or DLX) in order to protect the driver against flying debris. When mounted on Avant 600 series, the extra side weights (A49063) are also recommended for better stability.

- **Excellent visibility to the whole working area – the operator can look into the driving direction when mowing**
- **10 ft outreach**
- **Smooth and easy proportional controls with joystick**



600 and 700 series

Outreach	138 in
Cutting width	39.4 in
Weight	770 lb
Product no	A410727

419	420	520	528	630	635	640	745	750

Very compatible
 Compatible
 Incompatible



Edge trimmer

Avant edge trimmer is the perfect attachment for trimming the edges of lawns, hedges, flower beds etc. It consists of a hydraulically operated trimmer mounted next to a cutting disc.

Cutting disc cuts lawn precisely where you want and hydraulic trimmer breaks up any soil or lawn that is left to the side of the cutting disc. Edge trimmer leaves a good looking finish to any garden thanks to its adjustable cutting depth and precise control.

The edge trimmer can be mounted on both sides of the machine, which makes driving in confined places easier. The trimmer can also be mounted on both sides of the cutting disc, so that the operator can choose if the lawn edge is cut from the inside or outside.

- **Cuts the lawn edge accurately, leaving a finished look on lawns, flower beds, driveways, walkways**
- **Hydraulic trimmer mills the soil efficiently**

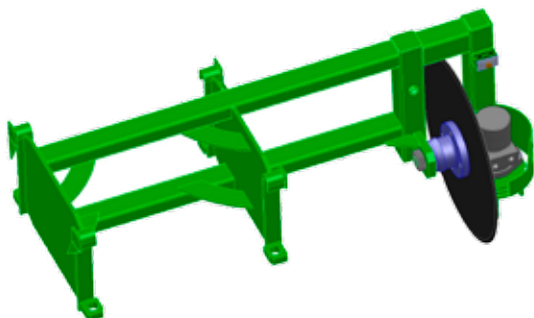

400, 500, 600 and 700 series

Cutting depth	max. 6.0 in
Weight	143 lb
Product no	A21068

419	420	520	528	630	635	640	745	750

Very compatible
 Compatible
 Incompatible



Rotary hoe

Avant rotary hoe is the basic attachment for soil cultivating, seed bed finishing and rotovating. Adjustable cultivating depth up to 6". Can be equipped with a field roller which compacts the ground after cultivating.

- **An inexpensive and robust rotary hoe**



400, 500, 600 and 700 series

Model	1100	1300
Working width	39.4 in	51.2 in
Working depth	2.0 - 6.0 in	
Weight	350 lb	395 lb
Product no	A2808	A21163

Optional extras:

- Field roller for 1000 model A2972
- Field roller for 1300 model A21164

Model	419	420	520	528	630	635	640	745	750
1000									
1300									

Very compatible
 Compatible
 Incompatible



Stone burier

A hydraulic stone burier for preparation of lawn beds. The stone burier mills the soil, buries stones and other objects up to 6.3" deep in a single pass, making a milled and tamped topsoil. Working depth is steplessly adjustable with the rear field roller. With the optional seeding unit you are able to make a ready lawn surface on one pass.

Stone buriers are most commonly used when the topsoil needs to be milled thoroughly. The soil is milled more thoroughly and deeper than with a rotary harrow.

- **Efficient stone burier**
- **Top grade finish with just one pass**
- **Can be equipped with seeding unit**



Optional extras:

- Seeding unit for 1130 model (A21011)
- Seeding unit for 1300 model (A21238)
- Seeding unit for 1500 model (A410304)

400, 500, 600 and 700 series

Model	1130	1300	1500
Working width	44.5 in	51.2 in	59.1 in
Roller width	52.0 in	59.1 in	66.9 in
Working depth	0 - 5.9 in		0 - 6.3 in
Weight	480 lb	550 lb	640 lb
Weight with seeding unit	550 lb	640 lb	730 lb
Product no	A21010	A21237	A410303

Model	419	420	520	528	630	635	640	745	750
1130									
1300									
1500									

Very compatible
 Compatible
 Incompatible



Rotary harrow

Avant rotary harrow is an excellent leveler for lawn beds, yards, gardens etc. – for places where the ground needs to be perfectly levelled. It harrows only the topsoil and gives a very nice finish for sowing. Required output is lower than that of the stone burier which allows also a higher working speed. Working depth is adjusted with the rear field roller which levels the seeding bed during operation. With the optional seeding unit you are able to make a ready lawn surface in one pass.

Rotary harrows are most commonly used for lighter topsoil levelling. The soil is normally not milled as deep or as thoroughly as with a stone burier.

- Efficient rotary harrow for topsoil levelling
- Top grade finish with just one pass
- Can be equipped with seeding unit
- Requires less power than stone burier



Optional extras:

- Seeding unit for 1350 model (A21085)
- Seeding unit for 1500 model (A21193)

400, 500, 600 and 700 series

Model	1350	1500	1700
Working width	48.0 in	55.1 in	61.0 in
Roller width	53.1 in	59.1 in	67.0 in
Working depth	0 - 6.3 in		
Weight	485 lb	550 lb	640 lb
Weight with seeding unit	575 lb	640 lb	730 lb
Product no	A21077	A21185	A21431

Model	419	420	520	528	630	635	640	745	750
1350									
1300									
1500									

Very compatible
 Compatible
 Incompatible



Leveller

A simple and inexpensive but incredibly useful and efficient attachment for levelling and planing of larger areas. With Avant leveller you can easily and quickly level sand, mulch etc. The leveller is most commonly used in:

- Preliminary lawn bed levelling
- Yard sand levelling
- Driveway levelling

The leveller can also be used for lifting job site materials like sod rolls, tools etc.

- **Economical attachment for levelling gravel and other soil materials**
- **Eliminates almost all manual shoveling at job sites**



400, 500, 600 and 700 series

Width	Weight	Product no
47.2 in	187 lb	A32411
59.1 in	210 lb	A33537

419	420	520	528	630	635	640	745	750



Ripper

The ripper is an inexpensive and practically irreplaceable tool in ground works. With the ripper it is easy and effortless to remove roots as well as rocks even from hard packed ground. The replaceable hard metal teeth guarantee a long lifespan for the attachment.

The ripper is operated by pressing the three blades into the ground next to the object you wish to remove. When the teeth have sunk into the ground, tilt the ripper inwards and then lift the boom upwards which will bring the object on top of the ground.

- **An inexpensive tool for removing of rocks, tree stumps, roots etc. from the ground**
- **Eliminates a huge amount of manual work**

400, 500, 600 and 700 series

Width	20.0 in
Working depth	approx. 12.0 in
Weight	110 lb
Product no	A44412



419	420	520	528	630	635	640	745	750



Very compatible



Compatible



Incompatible



Screening bucket

Avant screening bucket separates different sized soil materials effectively thanks to its unique construction. The purpose of the screening bucket is to separate larger and smaller particles from the soil and not crush the larger material into smaller particles.

The main advantage of the screening bucket is that no sharp particles are crushed into the material, making it safe to use in garden and park areas. Avant screening bucket also makes it possible to alter the topsoil composition for different uses. You can mix peat, sand, silt, clay or moraine into the topsoil, in order to make the soil composition right for different purposes.

Back fillings (padding) of pipes, cables and underground tanks are also ideal jobs for a screening bucket. One can screen the fine material on top of the pipes or tanks to protect them, and there is no need to transport finer material to the work site separately. On the demolition and construction site you can separate different sized construction and demolition waste, making it easier to recycle them.



- **Multi-functional.** Landscaping contractors can make topsoil directly on the work site with the same machine they are using for other jobs
- **Cost and time saving.** No need to transport ready screened topsoil to the work site
- **Heavy duty construction**

500, 600 and 700 series

Width	43.3 in
Bucket volume	6.4 cu ft
Screening area	3.6 sq ft
Blade clearance	1.0 in
Granule size	0-0.9 in
Weight	540 lb
Product no	A413784

419	420	520	528	630	635	640	745	750



Stump buster

A safer and faster way of removing tree stumps!
 The stump buster is an efficient, easy and safe way for removing tree stumps. The three blade drill head has slow speed and high torque, which means it can be used within confined spaces and pedestrian areas safely.
 The stump buster drills either a 10" or a 14" diameter hole into the tree stump, shaving off the wood as it turns.

The drive unit is equipped with a hydraulic motor and planetary gearbox which guarantee high torque and efficient cutting. The stump buster comes with a 20" long drive shaft and replaceable teeth blades. Teeth blades are made from very hard material which will give prolonged life in stoney ground conditions.



- **Safe way for removing of tree stumps**
- **Uncomplicated design, easy to operate**

400, 500, 600 and 700 series

Model	XHD92
Max. torque	4330 lb/ft
Drive shaft length	20.0 in
Weight	660 lb
Drive unit product no.	A33571

Drills:
 Drill 10", A33572
 Drill 14", A33573

419	420	520	528	630	635	640	745	750

Very compatible
 Compatible
 Incompatible



Stone grab

The mechanical stone grab is easy to mount on the Avant jib boom. Thanks to the powerful gripping force it can handle concrete components, curb stones, natural stones, tombstones etc.

The stone grab is equipped with:

- Lifting eye for attaching to Avant jib boom hook
- Automatic load release
- Changeable rubber covered steel grabs
- Spring loaded bolt for quick and easy opening width adjustment

The stone grab is best mounted on an Avant with telescopic boom. With the Avant jib boom (A32395) and telescopic boom extended the maximum outreach is 83", measured from the front wheel. When using the telescoping Avant jib boom A21342 maximum outreach is as high as 120".

ATTENTION! Avant jib boom (A32395 or A21342) is required for lifting of the stone grab.



- **Scissor type lifting device for:**
 - Curb stones
 - Concrete components
 - Tombstones
 - Natural stones
- **Scissor mechanism is completely mechanical, doesn't require hydraulics**

400, 500, 600 and 700 series

Gripping width	2.0 - 19.0 in
Jaw height	6.7 in
Jaw length	16.5 in
Lifting capacity	1985 lb
Weight	121 lb
Product no	A21179

419	420	520	528	630	635	640	745	750



Stone installation clamp

With the hydraulic installation clamp you can lay paving stones quickly and efficiently. The installation clamp takes a whole layer of paving stones directly from a pallet, which can then be lifted on to the area to be paved.

The hydraulic installation clamp is equipped with:

- adjustable side grippers for the exact shaping of the installation pattern.
- hydraulic rotation
- ADV pushing off device.

The ADV presses the blocks into the laying course automatically once the clamp is opened – this way the cocking of the blocks can be avoided and a lot of time is saved, because one doesn't have to reposition the blocks by hand. Avant jib boom (A32395) is also required, for lifting and handling of the clamp.

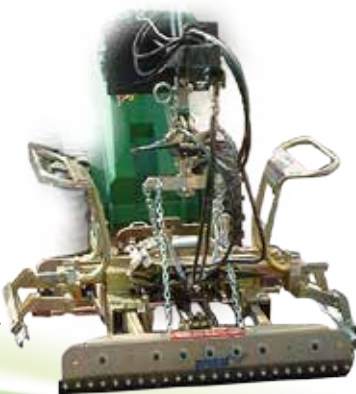

- **For fast stone laying**
- **Minimizes hand labor and intensive manual lifting**

400, 500, 600 and 700 series

Gripping width	22.6 - 49.0 in
Total width	39.0 - 58.3 in
Lifting capacity	880 lb
Weight	507 lb
Product no	A21180

419	420	520	528	630	635	640	745	750



Very compatible



Compatible



Incompatible



Grabbing tool

Grabbing tool is mainly intended for lifting and handling of round objects. It is especially suited for lifting of barrels and plant and tree pots. Grabbing force can be adjusted, which means all kinds of objects can be handled without damaging them.

Grabbing tool is equipped with two smaller, rubber padded grabs which allow handling of smaller and more fragile objects as well. When the grab is opened completely it can take larger objects like barrels, bigger plant pots etc.

- **Easiest way to lift and transport plants, trees, barrels etc. without damaging them**
- **Excellent tool for nurseries and landscapers**

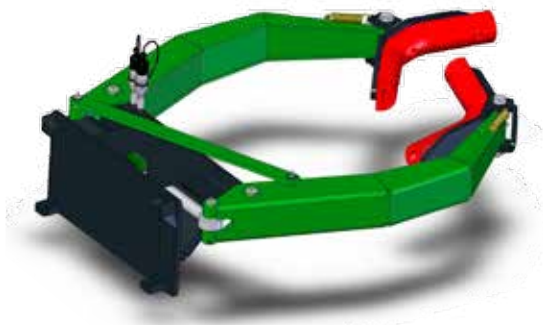

400, 500, 600 and 700 series

Min. grab diameter	10.0 in
Max. grab diameter	47.0 in
Max. load	1430 lb
Weight	210 lb
Product no	A34290

419	420	520	528	630	635	640	745	750





Backhoe 210

Avant backhoe 210's main focus in design was user friendliness and straight forward construction.

Boom movement speeds are steplessly adjustable, which makes operation easier also for inexperienced users. To facilitate the digging the frame of the backhoe is as low as possible, which gives unrestricted visibility to the work area.

- **A powerful, strong and compact backhoe**
- **Easy to connect and disconnect to Avant**
- **Smooth movements with precise control valve, easy to operate**
- **Uncomplicated and economical backhoe**

400, 500, 600 and 700 series

Max. Digging depth	82.7 in
Standard bucket	15.7 in
Weight	419 lb
Product no	A33747

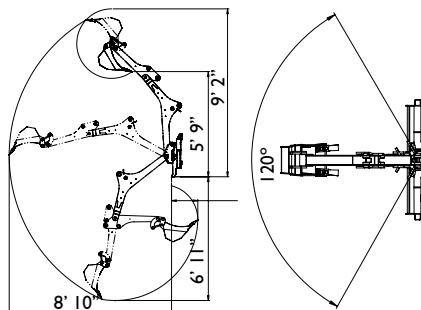
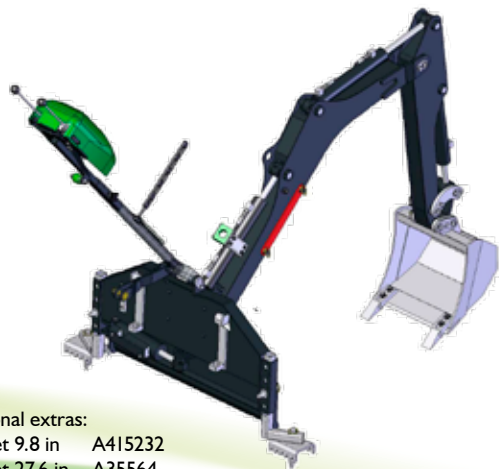

Optional extras:

Bucket 9.8 in A415232

Bucket 27.6 in A35564

419	420	520	528	630	635	640	745	750



Very compatible



Compatible



Incompatible



Backhoe 260

The Backhoe 260 has many advanced features: boom swing happens with two hydraulic cylinders, that gives more exact boom movements when swinging and requires less service. Swing angle is 170 degrees.

Backhoe 260 is equipped with hydraulic outriggers as standard. The operator can easily adjust the outriggers with the lever on the backhoe control valve. This allows quick and easy set up also on uneven terrains.

Changing of bucket is easy thanks to the quick attach mechanism. Mounting the backhoe on Avant is very fast, and the new foldable control valve bank and locking system on the boom make it even easier.

- **Powerful backhoe with good outreach**
- **Hydraulic outriggers**
- **Bucket quick attach system**
- **170° boom swing angle with consistent speed**
- **Dozer blade on front frame**
- **Several bucket options**

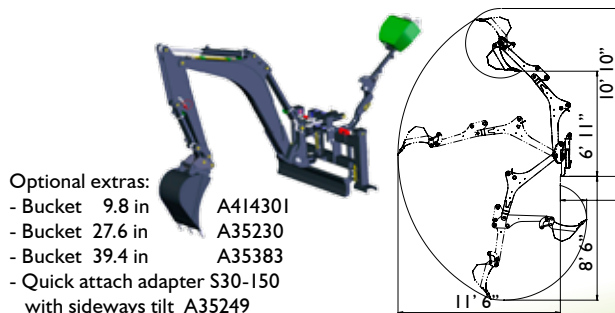

Optional extras:

- Bucket 9.8 in A414301
- Bucket 27.6 in A35230
- Bucket 39.4 in A35383
- Quick attach adapter S30-150 with sideways tilt A35249

400, 500, 600 and 700 series

Max. Digging depth	102 in
Width	51.2 in
Boom swing angle	170 °
Standard bucket	15.7 in
Weight	925 lb
Product no	A35248

419	420	520	528	630	635	640	745	750

Very compatible
 Compatible
 Incompatible



Mini digger

The mini digger is an efficient solution for small digging operations where maximum digging depth of 59" is enough and digging is not an everyday work. It mounts directly on the quick attach plate of the loader and is operated with the auxiliary hydraulics control lever. Dumping to the side happens by turning the steering wheel of the Avant. Bucket tilt adapter available as an option.

- **Very fast to mount on Avant**
- **Simple and light to transport from job site to another**
- **High unloading height**
- **Material can easily be transported further away**
- **Economical**



Optional extras:

Bucket tilt adapter	A35320
Bucket 9.8 in with teeth	A414301
Bucket 29.5 in straight edge	A35230
Bucket 39.4 in straight edge	A35383

400, 500, 600 and 700 series

Max. digging depth	59.1 in
Standard bucket	15.7 in
Buckets available	9.8/15.7/29.5/39.4 in
Weight	285 lb
Product no	A35317

419	420	520	528	630	635	640	745	750



Very compatible



Compatible



Incompatible



Trencher

With Avant trencher you can easily dig narrow trenches without damaging the ground on the digging area. The trencher digs a clean trench which can easily be filled with a bucket or a dozer blade. Planetary drive with hydraulic motor guarantee powerful and trouble free operation.

Digging depth is 35.4 in. Digging width is either 4" or 6", depending on the width of the trenching chain.

Trencher chains have tungsten reinforcements to ensure long lasting performance in all soil conditions.

- Trencher is ideal for smaller cable or pipe laying
- Digging speed with a trencher is 2-3 times quicker compared to a backhoe
- Combination of an articulated Avant and trencher leaves almost no marks of digging operations after the work is done. This makes it a perfect solution for gardens and other lawn areas.

- **Very fast and clean way to dig trenches for cables, drains, piping etc.**
- **Digs only 4 - 6 in wide trench and moves all ground to the right side of the trench**
- **Minimal damage to the ground on trenching area**

500, 600 and 700 series

Digging width	4.0 in	6.0 in
Digging depth	35.4 in	35.4 in
Product no	A33555	A33557

Other models (chain width & digging depth) also available, please consult your local Avant dealer.



419	420	520	528	630	635	640	745	750

Very compatible
 Compatible
 Incompatible



Auger

Powerful hydraulic auger with many different auger diameters to suit various tasks, be it post hole boring, tree transplanting etc. Standard drive unit has hydraulic motor and direct drive to the auger. Heavy duty drive unit is equipped with planetary drive to increase torque, needed especially in hard ground conditions or when using large diameter augers.

Replaceable tungsten teeth and pilot head are a standard feature in the auger drills. This enables drilling in hard ground as well as in sandstone.

Combination of an articulated Avant and auger offer excellent visibility and minimum ground damage.

Auger 3.0 in A34225

Auger 3.9 in A33601

Auger 5.9 in A33608

Auger 7.9 in A33609

Auger 8.9 in A33610

Auger 9.8 in A33611

Auger 11.8 in A33612

Auger 13.8 in A33613

Auger 15.7 in A33614

Auger 17.7 in A33615

Auger 19.7 in A33616



Auger 23.6 in A33617

Auger 29.5 in A33618

Auger 35.4 in A33619

Extension 19.7 in A33546

Extension 31.5 in A32532

Extension 39.4 in A33554

- Wide range of auger drive units with different torques enables efficient use of 3.0" to 35.4" auger drills
- The right drive unit for your work depends on the maximum drill diameter needed. Choose the drive unit from the table below
- The replaceable tungsten teeth on all auger drills ensure long lifespan also on professional day to day use

400, 500, 600 and 700 series

Model	Auger	Torque	Product no
Direct drive	3.0 - 11.8 in	1000 lb/ft	A21100
HD 35	3.0 - 15.7 in	1390 lb/ft	A34436
HD 45	3.0 - 23.6 in	1810 lb/ft	A33552
HD 58	3.0 - 29.5 in	2225 lb/ft	A33551
HD 72	3.0 - 35.4 in	2855 lb/ft	A34032



With Avant and auger drive unit you can install screw piles in the ground quickly and easily. The screw pile adapter mounts on the shaft of Avant auger drive unit and fits on Ø 2.36 in screw piles. 65826

419	420	520	528	630	635	640	745	750



Very compatible



Compatible



Incompatible



Hydraulic breaker

Avant breakers are specially designed for use with Avant loaders. From three different models you can find suitable for all 400, 500, 600 and 700 series models.

Avant loader with breaker is a very efficient tool in demolition and refurbishing operations: do the demolition with Avant and breaker, take the debris away with Avant and bucket – very fast and effective. Another benefit of this combination is its compact dimensions: you can go almost anywhere with this unit.

Avant breakers are the fastest, easiest and most efficient breakers for Avant loaders. All hoses, couplings and quick attach brackets are included in the package. In addition to this all set ups have been done to the breaker already at the factory so you can be sure you have a fully functioning package on the worksite.



- Top quality sound isolated Avant breakers are quiet and powerful
- Breakers are pre-adjusted at the factory to suit Avant loaders. There is a breaker for each Avant model
- All hoses and adapter plates are included in the packaging so the combination is all ready for work
- Multiple tools available for example: chisel, wedge,moil point and blunt.

400, 500, 600 and 700 series

Model	Impact energy	Weight	Product no
AVANT B70	83 ft-lbf	154 lb	A33811
AVANT B110	133 ft-lbf	243 lb	A33812
AVANT B160	200 ft-lbf	353 lb	A33813

Model	419	420	520	528	630	635	640	745	750
B70									
B110									
B160									

Very compatible
 Compatible
 Incompatible



Cutter crusher

Avant cutter crusher is intended for demolition work. With the cutter crusher you are able to crush the concrete, brick and cut the metal rebar into convenient pieces with the same tool.

The cutter crusher has changeable blades in both crushing jaw as well as in cutting jaw. The cutter crusher can be rotated endlessly straight from the operators seat with the help of an adjustable mechanical rotation.



- **Efficient, noise and vibration free crushing**

500, 600 and 700 series

Jaw opening	15.7 in
Max cutting force	169,000 lb
Max crushing force	54,000 lb
Rotation	360° (endlessly)
Weight	770 lb
Product no	A34357

419	420	520	528	630	635	640	745	750



Very compatible



Compatible



Incompatible



Concrete mixing bucket

Concrete mixing bucket is a handy tool when you need to make concrete without electricity or when you need to transport or lift the concrete to a difficult place. The bucket can be filled directly from the ground like a normal bucket and mixing is performed hydraulically.

Ejecting can be done by just opening the ejecting hatch or using the chute to guide the concrete.

- **Easy and efficient way to make concrete in places where electricity is not available**
- **The mixed concrete is easy and effortless to transport and pour into desired place**
- **Gravel can be filled into the bucket directly from the ground**
- **Concrete can be ejected up to 6.5 ft height. With the chute ejecting is easy and accurate**

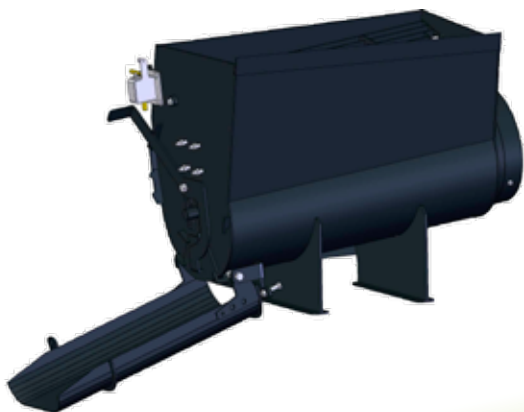

500, 600 and 700 series

Volume	Weight	Product no
9.5 cu ft	1080 lb	A21406

419	420	520	528	630	635	640	745	750

Very compatible
 Compatible
 Incompatible



Drum type concrete mixer

Concrete mixing drum is a handy tool when you need to make concrete without electricity or when you need to transport or lift the concrete to a place that is hard to reach. Mixing is done hydraulically and emptying is done simply by tipping the drum forward.

- **Economical attachment for more occasional concrete mixing**
- **Easy way to make concrete in places where electricity is not available**
- **Ready mixed concrete is easy to transport and lift to desired place**



400, 500, 600 and 700 series

Volume	2.8 cu ft
Operation	hydraulic
Weight	120 lb
Product no	A2950

419	420	520	528	630	635	640	745	750



Very compatible



Compatible



Incompatible

Asphalt grinder

The asphalt grinder, also called "cold planer" is an ideal attachment for asphalt road and pavement repairs and utility jobs. It grinds away the asphalt surface up to 3.15 in depth, making repair of potholes, utility cuts, small overlays and edge repairs fast and easy.

- Hydraulic side shift 19.7 in as standard



600 and 700 series

Working width	12.0 in
Operation	hydraulic
Weight	575 lb
Product no	A21230

419	420	520	528	630	635	640	745	750

Very compatible
 Compatible
 Incompatible

Vibrating plate

Vibrating plate is designed for earth compacting and is easy to attach to an Avant. Compacting is easy and safe with the vibrating plate connected to Avant's quick attach plate – the operator is not exposed to vibrations or excessive noise.

400, 500, 600 and 700 series

Weight	330 lb
Plate size	11.2 x 19.7 in
Impact force	1985 lb
Impact rate	2000 bpm
Product no	A21012



419	420	520	528	630	635	640	745	750

Very compatible
 Compatible
 Incompatible



Silage fork

A robust silage fork equipped with a powerful hydraulic cylinder, can be fitted on all Avant loader models. The strong blade type pins of the grapple penetrate into all types of feed. The fork has replaceable lower tines made of reinforced steel. The grapple goes up to vertical position and this, together with the powerful cylinder enables easy grabbing a round bale.

- **Compact model, which is well suited for silage distributing in small and confined places**
- **The front edges on the forks are rounded, which offers a smaller turning diameter**

400, 500, 600 and 700 series

Width	Weight	Product no
31.5 in	185 lb	A2868
35.5 in	220 lb	A31512
41.3 in	265 lb	A31519

NOTE! Avant 500, 600 and 700 series only with mounting bracket A34037



419	420	520	528	630	635	640	745	750



Very compatible



Compatible



Incompatible



XL Silage grab

The larger silage grab series is intended for Avant 500, 600 and 700 series loaders, with three different widths to match machines perfectly. The new series can carry up to 30 % more silage without losing visibility on the feeding table. Open grab construction on the top offers better visibility when the grab is open. Strong heavy duty construction with two cylinders. Forged bolt-on tines also on the top grab.

- Larger silage grab model
- The top grab construction is completely open from the middle which improves visibility when driving while the grab is open
- Top grab has two cylinders for improved compression power

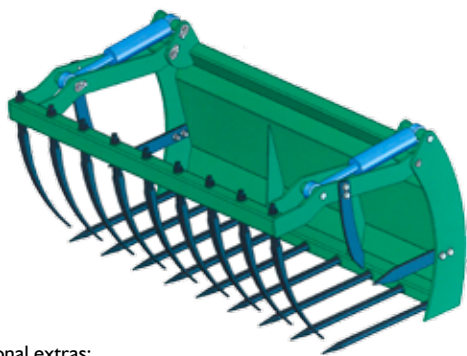

Optional extras:
Mounting bracket which increases tipping angle by 17° A34587

500, 600 and 700 series

Width	Weight	Product no
43.3 in	419 lb	A21385
51.2 in	441 lb	A21384
59.1 in	475 lb	A21380

419	420	520	528	630	635	640	745	750

Very compatible
 Compatible
 Incompatible



Feeding table cleaning blade

This cleaning blade is specially designed for clearing the cattle feeding table before distributing new silage to the table. The cleaning blade mounts directly on the silage forks which speeds up the cleaning process, because no attachment change is necessary. The cleaning blade has a rubber lip on the lower surface that ensures good cleaning result.

ATTENTION! Available only together with Avant silage forks.

- **The easiest way to clean the cattle feeding table**
- **Mounts directly on to Avant silage forks and locked into place with upper grapple.**
- **The cleaning blade can be mounted by driving the silage fork into the blade, no need to get out of the driver's seat**

For silage fork

Width	47.2 in
Side extension width	21.7 in
Weight	110 lb
Product no	A2936

For XL silage grab

Width	65.0 in
Side extension width	21.7 in
Weight	165 lb
Product no	A35512



Optional extras:

Extra side extension A46337

419	420	520	528	630	635	640	745	750



Very compatible



Compatible



Incompatible



Silage dispenser

This dispenser bucket is equipped with hydraulically driven elevator in the bottom and discharging to both right and left side. Especially recommended for precision chopped silage and feeding stuffs made with feed mixers. The dispenser bucket can be filled like a normal bucket directly from floor level.

- **A quick and easy way to distribute silage**
- **The silage can be distributed on both sides of the bucket without making any adjustments**



400, 500, 600 and 700 series

Volume	23.0 cu ft
Width	54.0 in
Weight	530 lb
Product no	A21000

419	420	520	528	630	635	640	745	750



Feed mover screw

Efficient way of moving uneaten feed back in front of the cattle. When moving, the screw mixes the feed and the fresh feed remains on top.

With the feed mover screw drive speed can be higher, over 6 mph. Feed can be moved both to the right and to the left simply by changing the rotation direction. The plastic scraper blade at the rear of the attachment cleans the feeding table very efficiently.

- **Fast and easy way of moving feed to the animals**
- **Discharge in both directions**
- **High efficiency, also on larger farms**
- **Scraper blade cleans the feeding table efficiently**



400, 500, 600 and 700 series

Working width	55.1 in
Total width	64.4 in
Weight	265 lb
Product no	A21506

419	420	520	528	630	635	640	745	750



Very compatible



Compatible



Incompatible



Silage block cutter

Powerful and robust silage cutters with two hydraulic cylinders. With the silage cutter you can easily cut silage directly from the silo and take it to the cattle. Cutting blades are made of special steel; they cut very efficiently and leave a clean and even surface in the silo. This prevents air getting into silage and warming up. Thanks to the open design of the cutting blade visibility during silage distribution is very good. Lower tines are made of hardened steel.

- **Strong and robust design, cuts efficiently also tightly packed silage**
- **39.4" cutter and 51.2" cutter**
- **Open design allows for good visibility also when distributing the silage**
- **Strong lightweight construction**
- **Tines made of hardened steel**



300, 400, 500, 600 and 700 series

Width	39.4 in	51.2 in
Weight	540 lb	617 lb
Product no	A21276	A21257

419	420	520	528	630	635	640	745	750



Carousel broom

The hydraulically operated carousel broom is a useful attachment when sweeping materials to the side or away from the wall. Rotates in both directions, can be used for various tasks especially in farm environment.

- **Strong broom, moves materials efficiently**
- **Side shift also allows for brushing next to the wall**



400, 500, 600 and 700 series

Width	39.4 in
Broom diameter	39.4 in
Broom material	Nylon
Weight	154 lb
Product no	A2971

419	420	520	528	630	635	640	745	750



Very compatible



Compatible



Incompatible



Bale fork

With the round bale fork transporting and lifting of unwrapped round bales is easy and safe. Square bale fork makes it easy and safe to transport and lift unwrapped square bales.

Strong and simple construction ensures a long lifespan.

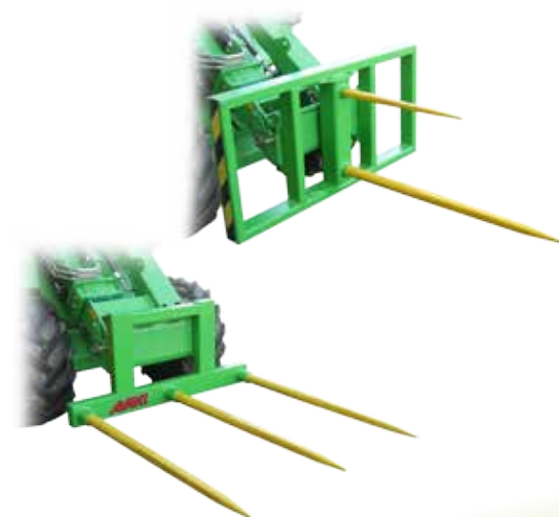

400, 500, 600 and 700 series

Model	Square bale fork	Round bale fork
Width	39.6 in	48.0 in
Length	45.1 in	45.3 in
Weight	130 lb	120 lb
Tines	3 pcs	2 pcs
Prod. no	A410225	A410224

419	420	520	528	630	635	640	745	750





Round bale grab

With the round bale grab you can lift and transport wrapped silage bales, hay bales and other round bales without damaging the plastic wrapping or net. Sturdy, yet light construction allows best possible effective load (see the table below).

- The round bale grab transports all wrapped bales without damaging the wrappings
- With Avant and bale grab you are able to pile three round bales on top of each other

400, 500, 600 and 700 series

Weight	265 lb
Max. bale weight	
Avant 400 series	880 lb
Avant 520	1215 - 1435 lb
Avant 528	1875 - 2095 lb
Avant 600 series	2095 - 2315 lb
Avant 700 series	2425 - 2645 lb
Max. grab width	59.0 in
Bale diameter	37.4 - 57.1 in
Product no	A21166



419	420	520	528	630	635	640	745	750



Very compatible



Compatible



Incompatible

Square bale grab

Square bale grab is destined for handling of wrapped silage bales, hay bales and other square bales without damaging the plastic wrapping or net.

Farming



400, 500, 600 and 700 series

Weight	310 in
Max. bale weight	2200 lb
Bale diameter	31.0 - 47.0 in
Product no	A410798

419	420	520	528	630	635	640	745	750

Very compatible
 Compatible
 Incompatible

Manure fork

Avant manure fork is a very useful attachment, destined for detaching and handling of manure and similar materials. The strong tines penetrate into compacted manure and can carry a heavy load.

- **Manure fork is now equipped with bolt-on replaceable tines, made of high tensile forged steel.**

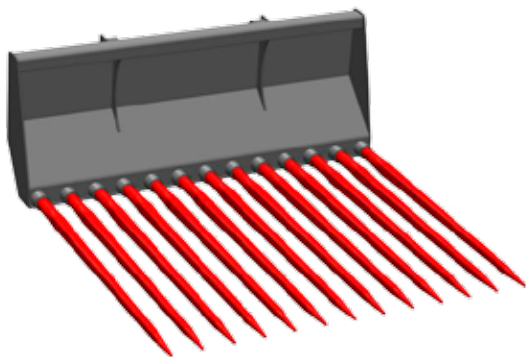

400, 500, 600 and 700 series

Width	43.3 in
Tine length	39.4 in
Fork length	43.7 in
Height	16.3 in
Weight	132 lb
Product no	A36038

419	420	520	528	630	635	640	745	750

Very compatible
 Compatible
 Incompatible

Straw blower bucket

With the straw blower bucket you can distribute straw quickly and easily to the cow stalls by driving with your Avant. The blower fan discharges the material up to 10 feet distance, depending on engine rpm. The bucket can blow chopped straw, sawdust, turf and small wood chips.

The bucket can be equipped, as an option, with a scraper blade which mounts under the bucket, destined for floor cleaning. With the optional side brush one can clean the rear part of the stall as well.

The bucket is available with discharge either to the left or to the right side.



400, 500, 600 and 700 series

Volume	23.5 cu ft
Height	50.0 in
Width	57.5 in
Weight	265 lb
Product no	A21066

Optional extras:

Rubber swiper for cleaning the manure grate. A46033

Sidebrush for cleaning the back part of the stall. A33025

Farming

419	420	520	528	630	635	640	745	750

Very compatible
 Compatible
 Incompatible

Grain/flour dispenser bucket

Avant grain dispenser is a 10.6 cubic foot bucket equipped with a hydraulic motor and a 8" screw, designed for distribution of flour, crushed grain etc. Discharge to the right side (on special request discharge to the left side available).

The edge of the grain dispenser tilts all the way down so that loading from ground level is easy.



400, 500, 600 and 700 series

Volume	10.6 cu ft
Width	43.3 in
Weight	198 lb
Product no	A1194

419	420	520	528	630	635	640	745	750

Very compatible
 Compatible
 Incompatible



Push broom

Push broom is a handy and inexpensive broom for cleaning of smaller areas. Push broom has no rotating parts - it simply pushes the material in front of the broom.

Push broom can be used when laying pavers. By pushing the filler sand sideways across the paving stones the sand will fall nicely between the stones.

- **An inexpensive and simple broom**
- **No rotating parts allows for less dust when brushing**
- **Works perfectly for horse stables, farms, other brushing applications**



400, 500, 600 and 700 series

Width	51.2 in
Weight	75 lb
Product no	A34055

419	420	520	528	630	635	640	745	750



Horse arena harrow

The horse arena harrow is intended for levelling and loosening of horse arena riding surfaces. The harrow has two spring loaded tine rows which will loosen the surface, a leveller that will make the surface completely even and a tilling roller that will compact the ground, leaving a great looking finish to the surface. The harrow will not damage the lower levels (understructure) of the riding surface.

The horse arena harrow features:

- A clearing shovel which will level the sides of the riding arena.
- A tilling roller that will smoothen the harrowed ground leaving a great looking finish.
- A large wheel that protects the walls of the riding arena in case the harrow hits the wall.
- Hydraulically operated support wheels for towing the harrow outside riding arena.

ATTENTION! Loader must be equipped with a single or double acting rear auxiliary hydraulics outlet and trailer coupling.

- **A professional harrow that makes it easy to keep the horse arena in top condition**
- **Can be adjusted for several kinds of riding surfaces**
- **Once the adjustments have been done the harrow is very easy to use**



400, 500, 600 and 700 series

Working width	53.0 in
Weight	530 lb
Product no	A21302

419	420	520	528	630	635	640	745	750

Very compatible
 Compatible
 Incompatible



Big bag transporter

With the big bag transporter you can lift and transport big bags safely and securely. This simple attachment makes loading of fertilizer or stacking big bags as easy as it can get.

- **An inexpensive and safe way to handle big bags**



400, 500, 600 and 700 series

Lift hook height	47.2 in
Width	39.4 in
Weight	176 lb
Product no	A21162

419	420	520	528	630	635	640	745	750



Stone collecting bucket

The stone collecting bucket - also known as riddle bucket - is intended mainly for collecting stones from the fields after the field has been harrowed. With an Avant 400, 500, 600 or 700 series it is easy and fast to collect stones from nearby fields.



400, 500, 600 and 700 series

Width	41.3 in	54.0 in
Bar diameter	0.9 in	1.2 in
Weight	210 lb	550 lb
Product no	A2999	A415432

Model	419	420	520	528	630	635	640	745	750
41.3 in	Very compatible	Very compatible	Very compatible	Very compatible	Very compatible	Very compatible	Very compatible	Very compatible	Very compatible
54 in	Incompatible	Incompatible	Compatible	Compatible	Very compatible	Very compatible	Very compatible	Very compatible	Very compatible

Very compatible
 Compatible
 Incompatible

Pressure washer

Powerful pressure washer with 65 foot hose reel; easy to take anywhere with the Avant. Creates maximum 8 gal/min water flow and 2900 PSI pressure. Can be connected directly to a water hose or a barrel.

Can suck water via inlet hose from as much as 10 feet below the level where the unit is. This is a very useful feature when taking water from a tank, reservoir, lake etc.



400, 500, 600 and 700 series

Mount	Max. water flow	Product no
Front	8 gal/min at 2900 PSI	A35411
Rear*	8 gal/min at 2900 PSI	A35457

* Rear mounting set is included, requires double acting rear auxiliary hydraulics from the loader.

419	420	520	528	630	635	640	745	750

Very compatible
 Compatible
 Incompatible

Compressor

Makes it possible to have compressed air anywhere you go. Creates maximum 105 gal/min at 115 PSI pressure. Can be used for running power tools and in circumstances where electricity is not available.



300, 400, 500, 600 and 700 series

Mount	Product no
Front	A35409
Rear*	A35456

* Rear mounting set is included, requires double acting rear auxiliary hydraulics from the loader.

419	420	520	528	630	635	640	745	750

Very compatible
 Compatible
 Incompatible

Log grab

The Avant log grab mounts on Avant pallet fork. With the log grab you can lift and transport single logs or smaller timber bundles. The grab is equipped with a powerful hydraulic cylinder and can therefore also lift bigger stones, as well as branches, fence poles and similar objects.

Requires also:

Pallet fork 33.5" (A21047) or

Pallet fork 43.3" (A21039)



- Easy mounting on pallet fork
- Basic attachment for fencing and forest work

300, 400, 500, 600 and 700 series

Max. diameter	Min. diameter	Weight	Product no
35.4 in	7.0 in	110 lb	A33503

Assembled to pallet forks

419	420	520	528	630	635	640	745	750

Very compatible
 Compatible
 Incompatible

Log grab, heavy duty

A strong log grab for customers who need to move tree trunks, logs etc. The grab takes a firm grip on the wood and the lower tines are also better formed for grabbing bigger tree trunks.



400, 500, 600 and 700 series

Width	33.3 in
Height	39.0 in
Weight	396 lb
Product no	A415691

419	420	520	528	630	635	640	745	750

Very compatible
 Compatible
 Incompatible

Tree shear

Avant tree shear is an efficient and useful tree cutter, intended for forest thinning, tree clearance and similar jobs where smaller trees need to be cut. The strong grapple takes a firm grip of the tree trunk and a hydraulic cylinder pushes the cutting blade against the trunk and cuts it. The tree is then easy and fast to move away with Avant. If needed, the cutting blade can be turned 180 degrees to point backwards. This means it doesn't cut and the unit can be used as a grapple only.

Forestry



400, 500, 600 and 700 series

Tree diameter	max. 7.5 in
Grapple opening	30.3 in
Weight	243 lb
Product no	A35831

419	420	520	528	630	635	640	745	750

Very compatible
 Compatible
 Incompatible

Winch

The Avant hydraulic winch enables towing of all kinds of objects (e.g. logs, poles, boats) from places where you cannot drive with the machine.

The winch is equipped with a safety net, 100 feet of cable and a towing hitch. It is powered by a powerful hydraulic motor and mounts on Avant's quick attach plate.

Use of the winch is simple, one person can easily handle it.

The auxiliary hydraulics lever is switched to continuous flow from the driver's seat, which releases the cable drum so that the cable can be pulled out by hand. When the cable is attached to the desired object, operator returns to driver's seat and turns the auxiliary hydraulics lever into opposite direction and the winch begins to reel in the cable.



- **Powerful and compact hydraulic winch for various tasks**
- **The winch is mounted directly on Avant's quick attach plate, so you are also able to use the boom for lifting materials with the winch**

400, 500, 600 and 700 series

Max. Pulling power	2200 lb
Max. Reeling speed	7.5 ft/sec
Cable length	100 ft
Weight	231 lb
Product no	A33130

419	420	520	528	630	635	640	745	750

Very compatible
 Compatible
 Incompatible



Log splitter

Avant log splitter is the right attachment when you have cut logs and need to make firewood quickly and easily. Log splitter is equipped with a hydraulic cylinder which pushes the log against the splitting blade. Height of the blade is adjustable, allowing splitting either into two or into four pieces.

The splitter has automatic reverse and cylinder stroke can be adjusted with a limit switch. Safety features include a stop switch which prevents operation if the blade cover is not down. Transportation is easy – the splitter mounts on the quick attachment plate of the loader.

- **Economical, powerful log splitter**
- **Max. log diameter 15.7"**
- **Two models: 1) for logs with max. 23.6" length and 2) for logs with max. 39.4" length**

400, 500, 600 and 700 series

Max. log diameter	15.7 in	15.7 in
Max. log length	23.6 in	39.4 in
Feeding speed	approx. 30 logs/min	
Splitting force	8.4 tons	11.0 tons
Weight	330 lb	550 lb
Product no	A413181	A413195



419	420	520	528	630	635	640	745	750



Very compatible



Compatible



Incompatible



Log cutter/splitter

Avant log cutter/splitter is a very efficient firewood making machine. It combines a chain saw and a hydraulic log splitter.

The hydraulically driven chain saw cuts the log, after cutting the log drops automatically on the splitting table where a hydraulic cylinder pushes the log against the splitting blade. Position of the splitting blade can be adjusted, according to the log diameter. The unit is equipped with a separate system with own oil tank for lubricating the saw chain. Discharge conveyor is available as an option.



- **Powerful and safe log processor**
- **Automated functions make work efficient**
- **Discharge conveyor available as an option**

400, 500, 600 and 700 series

Max. log diameter	12.0 in
Max. log length	18.0 in
Saw flange	13.0 in
Max. splitting force	6.2 tons
Conveyor belt length	7.5 ft
Weight	688 lb
Weight with conveyor	850 lb
Product no	A415435

Optional extras:
Discharge conveyor 65673

419	420	520	528	630	635	640	745	750

Firewood machine

With the firewood machine you can easily make firewood for your own needs. Cutting of the log happens by pushing it against a 27.6 in hard metal saw blade. After that the log must be lifted by hand to the splitting table and split by pushing the log against a rotating splitting screw.



200, 400, 500, 600 and 700 series

Log diameter	max. 11.8 in
Log length	max. 23.6 in
Saw blade diameter	Ø 27.6 in
Splitting screw	Ø 3.9 in
Weight	386 lb
Product no	A35823

Forestry

419	420	520	528	630	635	640	745	750

Very compatible
 Compatible
 Incompatible

Wood chipper CH100

A wood chipper that works also on Avant 400 series. Ideal unit for chipping wood on a smaller scale. Wood feeding is manual.



400, 500, 600 and 700 series

Max wood diameter	4.0 in
Chipping drum	Hydraulic motor with direct drive
Chute turn	180° (can be mounted to eject to the right or to the left)
Weight	460 lb
Product no	A415436

419	420	520	528	630	635	640	745	750

Very compatible
 Compatible
 Incompatible



Wood chipper CHI50 heavy duty

Avant CH 150 is a powerful wood chipper, equipped with a feeding unit which draws even the most stubborn tree branches into the chipper. The unit is equipped with two feed rollers that are governed by an rpm guard on the chipping drum.

The chipping drum will not seize, because when the chipping drum rpm is too low the feed rolls will stop and allow the chipping drum to gain rpm again.

The CHI50 is designed for landscapers and property maintenance companies who require a high efficiency from the chipper.

- **Powerful wood chipper**
- **Automatic feeding and rpm guard (no-stress in-feed control) make chipping easier and more efficient**



635 and 700 series

Max. timber diameter	6.0 in
Feed rollers	2 pcs
Chute rotation	270 °
Weight	1080 lb
Product no	A414031

419	420	520	528	630	635	640	745	750



Tilt adapter

Avant tilt adapter is mounted between the attachment and the loader's quick attachment plate. It enables the driver to tilt the attachment maximum 12.5 degrees in both directions from the driver's seat. The tilt adapter makes it possible to:

- Make different forms to the ground with a normal bucket
- Keep pallet forks level when you are driving on uneven surfaces
- Load pallets that are on uneven ground
- Level ground on uneven surfaces

The tilt adapter is intended mainly for non-hydraulically operated attachments, but with the optional second auxiliary hydraulics outlet in the front it is possible to mount also hydraulically driven attachments like a 4 in 1 bucket at the same time.

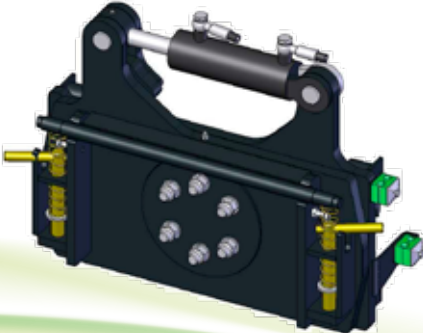

- Adds flexibility to work

400, 500, 600 and 700 series

Max. tilt	+/- 12,5°
Weight	145 lb
Product no	A34148

419	420	520	525LPG	528	630	635	640	745	750



Very compatible



Compatible



Incompatible

Receiver hitch

Rear mounted 2 inch receiver hitch.

Options



400, 500, 600 and 700 series

Model	Product no
Receiver hitch	HH2INREC

419	420	520	528	630	635	640	745	750

Very compatible
 Compatible
 Incompatible

Attachment control switch pack

Optional extra with which electric functions of the attachment (electric throwing height adjustment on snow blower, opening of lawn mower collector lid, control of water spraying system on the broom etc.) are controlled

Does not require the optional 8 function joystick on the loader, mounts on the std. boom control lever also. Consists of the control switches, wiring and a 7-pole socket that mounts on the boom next to the auxiliary hydraulics quick couplers. The electric wire of the attachment is connected to this socket.

Operation of the attachment's electric functions is very comfortable and easy, because the toggle switches are mounted on the control lever within reach of your right thumb.



400, 500, 600 and 700 series

Model	Product no
Attachment control switch pack	A34700

419	420	520	528	630	635	640	745	750

Very compatible
 Compatible
 Incompatible

Adapter plate

Avant offers a variety of original adapter plates, which can be welded directly onto:

- An attachment you have developed yourself.
- An object you wish to lift securely with Avant

All original Avant adapter plates will fit, which saves a lot of time consuming measuring and adjusting work from you.

400, 500, 600 and 700 series

Model	Product no
Quick attach brackets, 400/500/600/700 series	A31566
Adapter plate 0.4 in 400/500/600/700 series	A2471
Adapter plate 0.8 in 400/500/600/700 series	A2472

Options



419	420	520	528	630	635	640	745	750

Very compatible
 Compatible
 Incompatible

Skid-Steer Attachment Mounting Adapters



Universal Skid-Steer Attachment Mounting Adapter
Product no. BER-QTFS



MT Skid-Steer Attachment Mounting Adapter
Product no. BER-QTMT



Mini Skid-Steer Attachment Mounting Adapter
Product no. BER-QTMINI

419	420	520	528	630	635	640	745	750

Very compatible
 Compatible
 Incompatible

Multi Connector System

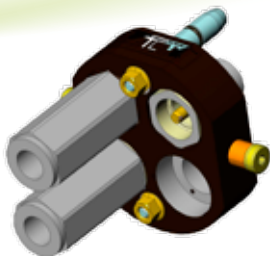

Multi connector Pressure-Return
65251



Multi connector Pressure-Tank line
65371



Multi connector Pressure-Return-Tank line
65250



Adapter: Skid-Steer attachments to Avant Multi connector System
CE565-9656



Multi connector Parking
65594

AVANT[®]

Avant Tecno USA Inc.

3020 Malmo Drive

Arlington Heights, IL 60005

847.380.9822 phone

847.380.9823 fax

e-mail: sales@avanttecnousa.com

AVANT has a policy of continuing improvement,
and retains the right to change specifications without notice.
© 2014 AVANT Tecno Oy. All rights reserved.

www.avanttecnousa.com