



Audi India
Division of Volkswagen
Group Sales India Private Limited
Mumbai - India
www.audi.in
Valid from November 2014

Printed in India
Q5 DJ 1

The models and equipment versions illustrated and described in this brochure and some of the services listed are not available in all countries. Some of the cars illustrated are equipped with optional features for which an extra charge is made. Details concerning the delivery specifications, appearance, performance, dimensions and weights, fuel consumption and running costs of the vehicle were correct to the best of our knowledge at the time of going to press. Deviations from the colours and shapes shown in the illustrations may occur. No liability is accepted for errors and printing errors. The right to introduce modifications is reserved. Not to be reproduced, including in part, without the written approval of AUDI AG.

U50401MH2007FTCL68439

Audi Q5

Q5

Audi Q5



Vorsprung durch Technik 

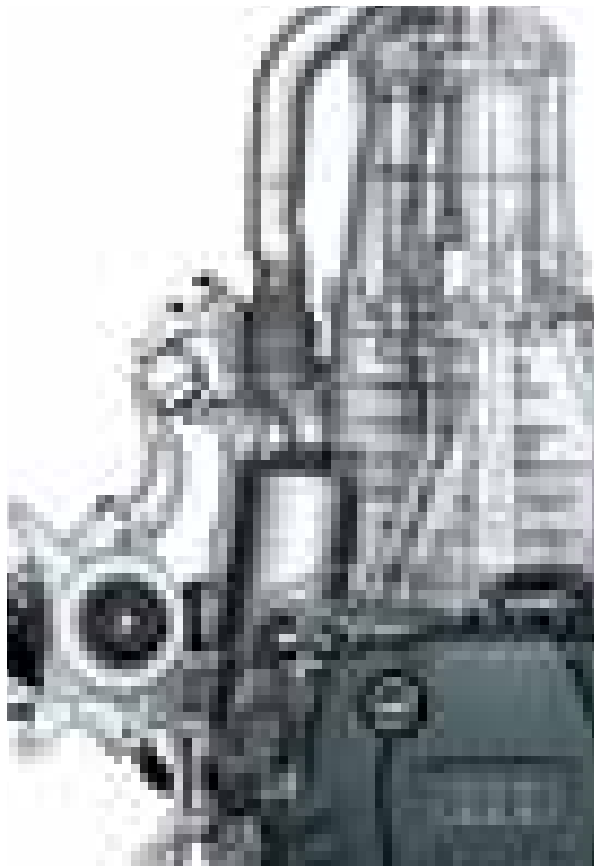

	Page	
Fascination	01 The Audi Q5 Experience	
Technology	21 Audi efficiency	27 quattro®
	23 Audi ultra	29 Suspensions, offroad, ESC
	25 TDI®	31 Audi drive select
		33 MMI® – Multi Media Interface
Equipment	35 Paint finishes/Inlays	41 Interior equipment
	36 Wheels/tyres	42 Infotainment
	37 Seats/seat upholstery	43 Assistance systems
	38 Lights and mirrors	45 Technology
	39 Exterior equipment	47 S line package
		49 Audi Genuine Accessories
Other	51 Standard Equipment	53 Dimensions
	54 Equipment list	55 Technical data



**Question things.
Change things.
New intelligence.**

Each generation creates its own new ideals. Things change – be they working conditions, recreational activities or even planning a family. And it's a good thing they do! Because only changes enable a new way of thinking.

Audi has always adhered to this principle and has built cars to set new standards. One of these cars is the Audi Q5. It intends to convince rather than persuade; it is efficient without spoiling driving enjoyment, it is sporty but still level-headed. It combines sensible technologies with traditional qualities such as intelligence, comfort and power. Experience a progressive way of getting around in the Audi Q5.

Q5

**No make-up.
A lot of expression.
New views.**

You will recognise the sharpened, striking design of the Audi Q5 at first glance. Generously wide rear lights give the car a distinct accent. Combined with the xenon plus headlights, the rear lights use LED technology and have a striking light strip. The emphatic rear diffuser and the flat-bottomed tailpipes give the rear an even more masculine look.

Practical and attractive: the encompassing tailgate. It not only lends an unmistakable appearance to the rear, it also makes loading and unloading of the large luggage compartment more comfortable. Webless, joint-free, shiny roof rails and the corresponding removable roof crossmembers are part of the standard equipment.





Exact lines, smooth surfaces, a three-dimensionally designed bonnet – the Audi Q5 radiates both sportiness and elegance. And its appearance makes its presence felt: with a vehicle length of 4,629 mm and a width of 1,898 mm, it draws your attention. Yet it still has one of the best drag coefficients in its class, which it owes among other things to its coupé-like roof line. And its power is immediately apparent.



The typical Audi face has been re-interpreted: the precise workmanship of the Singleframe radiator grille in high-gloss black with vertical chrome struts, front fog lights with chrome rings, webs in high-gloss black on the delicate air intakes and the trapezoidal bumper are all signs of a strong character. Many details reinforce this impression. The electrically adjustable exterior mirrors have integrated LED indicators. The xenon plus headlights feature a bright LED daytime running light whose striking, homogeneous light strip is unmistakable.



**Show strength.
Keep moving.
Reach new goals.**

High in torque and efficient: the engines in the Audi Q5. The TDI engines have the common rail system and are characterised by quiet operation, impressive engine acoustics and agile driving behaviour. That puts you more efficiently on the road without spoiling your driving enjoyment.



An exciting journey begins with good equipment. The new standard electromechanical power steering works depending on the speed and ensures greater steering precision and comfort. In addition, it only uses fuel if you actively request steering support.

The remarkable driving stability, on the other hand, is thanks to the dynamic suspension. Its finely-tuned spring/shock absorber setting leads to high ride comfort and relaxed driving on long stretches – with no loss of agility.

Stay on track: the quattro permanent all-wheel drive helps you drive around corners, in snow, on wet road surfaces and across almost any ground. S tronic® can be operated via the multi-function steering wheel. Due to the dual-clutch transmission, the next gear is already engaged before you select it. That means you can change gear with virtually no perceptible break in propulsive power. And the S tronic ensures comfortable yet sporty gear changes. Q5 30 TDIq and Q5 45 TDIq will have the 7-speed S tronic.



**More space.
More demands.
New possibilities.**

Get in – and immediately feel at home. Surrounded by luxury, great attention to detail and many intelligent features which make the time you spend in the Audi Q5 very pleasant.

The instruments are sensibly and ergonomically arranged – as the driver you have all the important information available at a glance. The driver information system helps you to actively save fuel: through consumption data overviews, a display of additional consumers and fuel-saving tips for adopting an economical driving style. Another feature is the attention assist in the driver information system which analyses driving behaviour and recommends breaks, thus supporting the driver during longer journeys.

At the top of the instrument panel there is a large display which clearly shows the contents of the radio systems and the optional MMI navigation systems.

Not only the numerous infotainment possibilities in the interior are impressive, so is the sound quality of the sound systems. You can listen to music from your iPod or a USB medium via the Audi music interface.





Enjoy your view of the road – from a relaxed higher seating position. Allow the interior of the Audi Q5 to work on you: soft materials or, sophisticated leather impart a comfortable feeling. Just as impressive: the space capacity and variability of the Audi Q5. And the panoramic glass sunroof conveys a new sensation of space and gives you a clear view of the sky.

The generous load area can accommodate almost everything you need for a relaxing holiday, an extensive shopping spree or a spontaneous weekend trip. The low loading height makes loading really easy. The loading width of 1,050 mm adds to the convenience. Underneath the loading floor there is an additional storage compartment which can be equipped with a dirt collecting tray upon request. The rear seat system plus with its through-loading facility and the rear seats which are longitudinally adjustable by 100 mm again increase the load volume. The rear seat backrest can be split-folded 40:60 or completely.





A journey in the Audi Q5 comes to an end: full of comfort and sportiness, relaxation and dynamics. The Audi Q5 includes an impressive amount of intelligent technology because you should be able to decide what's important to you.

Your Audi also bears our mark of special efficiency.

Our vehicles embody not only sportiness, progress and technical innovations, but also the intelligent use of resources.

One example: the TDI engines with common rail technology. Their combination of direct injection and turbocharging guarantees highly efficient diesel fuel combustion. Audi engines have been subject to an ongoing development process for years. This means that today they are more powerful than ever before – despite reduced overall weight and thus reduced consumption. Impressive proof of our strategy of obtaining more power from less engine displacement. The start-stop system guarantees even more efficiency.

The dual-clutch transmission S tronic makes ideal use of the high-torque Audi engines: its large transmission ratio spread allows it to accelerate strongly even at low engine speeds; this reduces fuel consumption.

The thermal management, which purposely distributes heat between the engine, transmission and interior, shortens the engine warm-up period and reduces engine and transmission friction respectively.

You see, the Audi Q5 features a whole range of technologies that will make your journey not only more comfortable and dynamic, but more efficient, too. Find out more on the next few pages.





Audi ultra on the podium: the Audi R18 TDI

Audi ultra:

Every gram less extends the lead.

Audi ultra, the pioneering lightweight technology from Audi, is more than just the sum of its individual components. It combines innovative materials, intelligent design principles and production processes that use resources sparingly into an overall concept. Many Audi ultra lightweight measures have already been implemented in the Audi Q5.

That starts with the body itself. The steel shell design of the Audi Q5 combines low weight with high rigidity. The tailor-made floor pan is made of different material thicknesses and qualities. The design uses only as much material as necessary in the respectively right places.

The principle has convinced others, too: when it was launched in 2008, the Q5 body was honoured with the world's top prize for bodywork, the EuroCarBody Award*.

Extended use of hot- and cold-formed steels of high rigidity classes allows thin metal panels to be used for the body. The aluminium components on the front and rear axle and the lightweight cast aluminium wheels not only reduce the overall weight but also the unsprung masses, which in turn leads to an increase in driving comfort. A lightweight brake reduces weight even further.

Drive technologies such as direct fuel injection and turbocharging have made Audi engines more powerful. The modern TDI engines in the Audi Q5 produce more power with a smaller engine size, making them significantly lighter than the corresponding engines used in earlier model series.

About weight reduction

The demands placed on modern vehicles are contradictory. On the one hand, they must offer enhanced performance and comfort, on the other they need to be more economical and efficient. Audi ultra resolves this conflict by examining each and every component. We demand the highest functionality combined with the lowest possible weight. The result is an intelligent mix of materials that even allows a reduction in engine size: lighter vehicles no longer need a large engine to be agile. In 2011, for example, the R18 TDI won in Le Mans with a V6 engine, whereas its victorious predecessor, the R15 TDI, had featured a V10 engine.

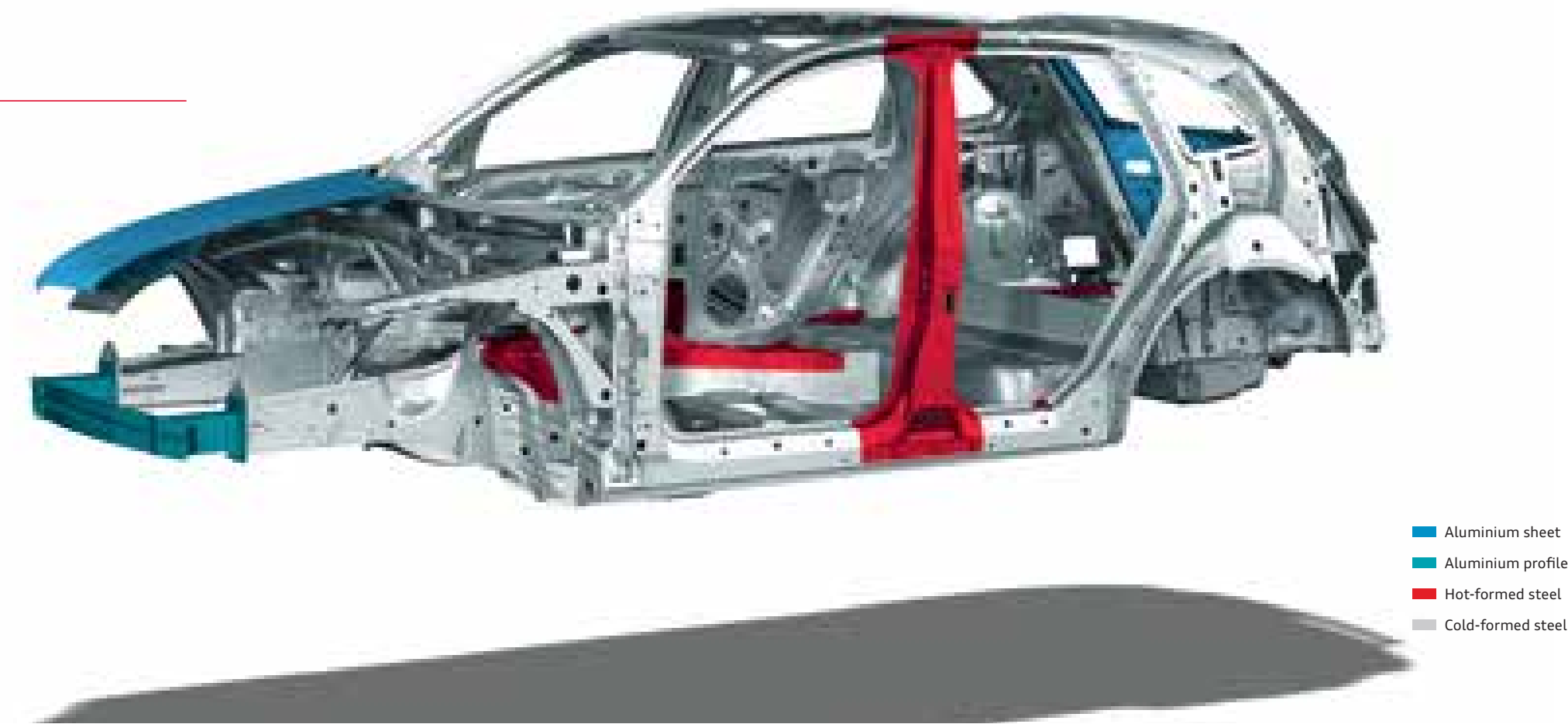

- Aluminium sheet
- Aluminium profile
- Hot-formed steel
- Cold-formed steel

*International Body Benchmark Conference EuroCarBody 2008, press release cf. www.automotive-circle.com/pdf/ecb08/ecb_press_e.doc.



The injectors open and close in fractions of a millisecond and inject fuel several times into the combustion chamber at pressures of up to 1,800 bar. In some cases, an injection process can involve the injection of the tiniest of amounts weighing less than a thousandth of a gramme.



Pre-injection results in a "gentle" combustion process and consequently excellent combustion acoustics and agreeable engine running characteristics.

TDI®

In other words: where is the tank?

One in every two Audi cars sold today is a diesel. What sounds perfectly normal now was cause for huge excitement 20 years ago, when Audi revolutionised the market with the first 2.5 litre TDI engine. Since then, developments such as common rail technology have made TDI even more efficient. Injectors ensure the fuel is finely and precisely distributed. Consequently, since the first TDI, the engines have become more economical, whilst specific output has increased. So it was only logical that a diesel car should then enter the world of motorsport. And successfully

too: in 2006, Audi was the first car maker to win the Le Mans 24 Hours with a diesel-powered race car, the Audi R10 TDI – a victory which it has repeated several times over, most recently in 2011.

With 130 kW of power the 2.0L TDIq engines in the Audi Q5 are convincing from the very first metres. The 2.0L TDIq S tronic engine with 130 kW reaches its maximum torque of 380 Nm at just 1,750 rpm and develops its power thrillingly evenly. You reach 100 km/h in 9.0 seconds. The most powerful diesel engine

in the Audi Q5 is a 3.0L TDIq engine with 180 kW and 580 Nm, which accelerates your car from 0 to 100 km/h in only 6.5 seconds. But even if you're not in the process of overtaking, you can fully enjoy the superb driving feeling: sporty and demanding – yet at the same time relaxing and efficient, because the recuperation is standard in all models with a TDI engine.

turbo charger with improved adjustable turbine geometry

1,800 bar high-pressure injection system

engine with reduced friction

pressure-regulated oil pump

innovative thermal management with separate cooling system for cylinder head casing/cylinder head



3.0L TDIq engine (180 kW)

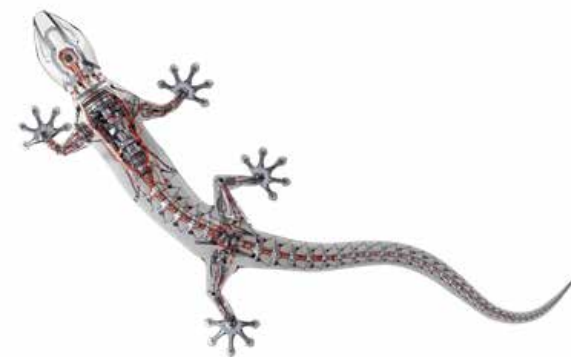

Why only use two wheels when a car has four?

The quattro® permanent all-wheel drive.

quattro is a permanent all-wheel drive. If the wheels on one axle of the vehicle lose grip on the road and threaten to spin, then the drive force is transferred to the other axle – automatically and permanently distributed through the self-locking centre differential with wheel-selective torque

distribution. The basic distribution is 40:60 – 40% of the power goes to the front axle, 60% to the rear. The benefit is better traction during acceleration and improved safety due to impressive grip.

So much for the technology. But what makes quattro so special is really the driving feel. “As if you’re stuck to the road,” some customers say. We put it like this: quattro gives you more feel for the road and thus increased safety.

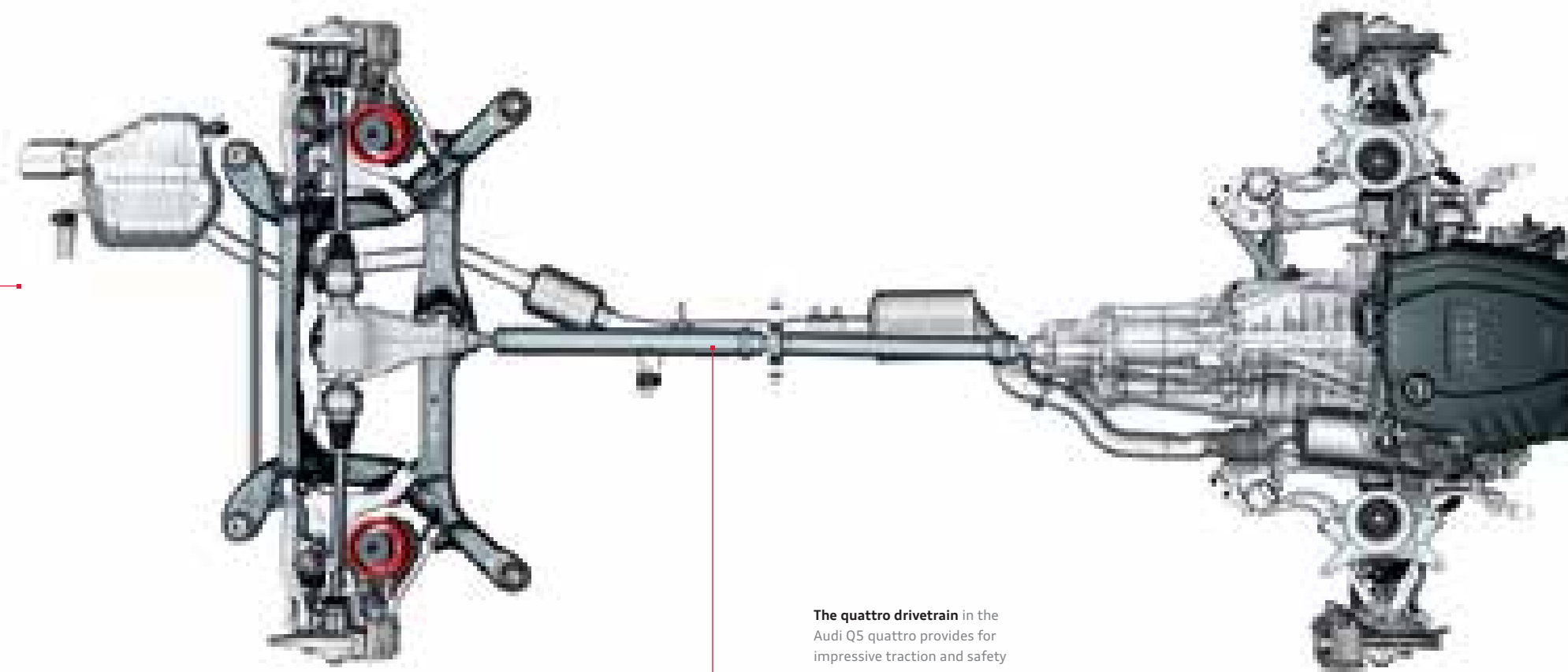

The quattro drivetrain in the Audi Q5 quattro provides for impressive traction and safety

Superb performance can be learnt.

From one's suspension, for instance.

Driving an SUV should feel sporty and agile. In the Audi Q5, the dynamic suspension works with a 5-link front axle and trapezoidal-link rear axle. Both elements enable a fast power build-up and ensure remarkable driving stability, a comfortable ride and good directional stability.

In addition, there is an optional suspension with adaptive damper control available. The infinitely variable damping adjusts itself automatically to every driving situation in fractions of a second. The damper control solves the classic conflict between sporty and comfortable suspension tuning and is particularly effective in an SUV with a high centre of gravity and large spring travel.

The Electronic Stabilisation Control (ESC) provides intelligent technical support: this vehicle

stabilisation system is, of course, standard. A sensor system recognises whether you have attached the standard roof crossmembers. The system then adapts to the higher centre of gravity caused by the load.

Just as intelligent is the electromechanical power steering fitted as standard. It is speed-sensitive, meaning that you enjoy a precise steering feeling at high speed and greater steering convenience when parking.

And if you want to go offroad for a change: with an overhang angle of 25°, a ramp breakover angle of 17.6°, a climbing ability of 31° and a ground clearance of 200 mm, there is barely an obstacle the Q5 cannot overcome. ABS with traction improvement recognises when you are

driving offroad and adapts functions accordingly. And at the push of a button you can adjust the ESC support to offroad operation; ASR then ensures better grip, even on debris or gravel.

The standard hill descent control helps to maintain the speed specified by the driver within system limits even on steep descents.



trapezoidal-link rear axle
with independent suspension

5-link front axle

Why does the Audi Q5 suit you so well? Because it adapts itself to you so well.

Audi drive select.

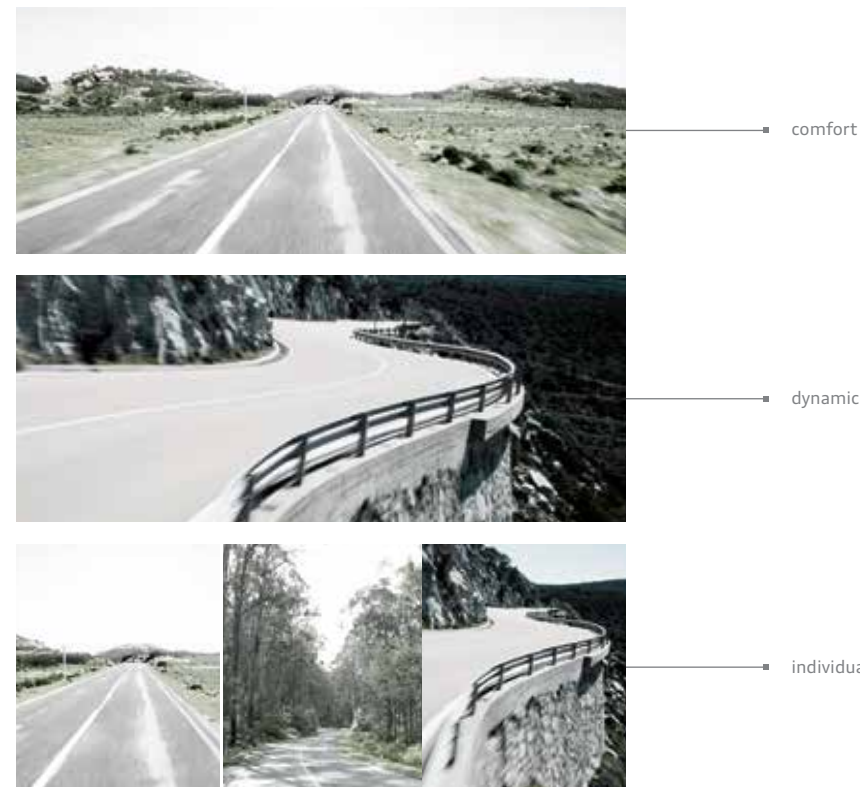

Everybody defines driving dynamics differently. We define it like this: drive exactly how you feel. With the optional Audi drive select, you can influence individual vehicle components at the push of a button and so change the character of your Audi.

You have four modes to choose from: comfort, dynamic, auto and - in conjunction with an optional MMI navigation system, individual

mode, allowing you to determine yourself how the associated vehicle components should behave. The comfort mode is especially suitable for providing the most relaxed driving possible on long journeys. The auto mode offers a generally comfortable yet firmer driving experience. For particularly sporty driving, for example on winding roads, there is the dynamic mode. In every mode, the vehicle adjustments depend on the equipment present. Thus Audi

drive select influences the engine, the steering and, in the case of S tronic or tiptronic, the gear changing behaviour of the automatic transmission.

The engine and gears react more spontaneously or in a more balanced manner to movements of the accelerator, depending on the mode chosen. Moreover, the engine speeds at which gear changes take place are varied - in dynamic mode,

they only happen at higher engine speeds, while in comfort mode they take place at lower ones. The steering can also be adapted to the driving situation, from sporty and firm to comfortable.



Radio: The integrated radio receiver is set up for VHF, LW and MW and optionally delivers digital radio with a continually updated station list



Telephone/Bluetooth: The preparation for mobile phone (Bluetooth) has a selection screen containing call lists, directory and selection interface as the startup setting.



Media: Display of available media sources such as the jukebox, inserted SDHC cards, Audi music interface or CDs and DVDs.

Follow your intuition.

And you'll get there.

We try to match up to our claim of "Vorsprung durch Technik" in every aspect of an Audi – for example with the MMI – Multi Media Interface. The MMI is used to control a wide variety of media in the car, as well as the navigation system and other convenience functions.

Until now, the MMI has been easy to use – but the

MMI navigation plus makes it even easier. A reduced number of buttons brings greater clarity.

All six so-called hard keys, for telephone or navigation functions for example, are located around the central rotary/push-button control – for intuitive operation. The buttons for radio and

media are logically arranged near the volume control. Another new feature is the carousel layout in the MMI display. This provides you with an even better overview, making it even easier for you to get to where you want to be.



Solid paint finishes



Ibis white

Metallic paint finishes



Scuba blue, metallic



Florett silver, metallic

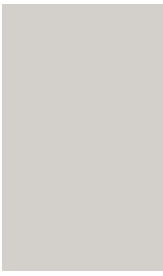

Inlays



Walnut brown



Teak brown, metallic



Monsoon grey, metallic



Paint finishes

Solid paint finishes

front and rear bottom bumper section and door trim strips in matt black (choice of contrasting or full paint finish)

Metallic/pearl effect paint finishes

front and rear bottom bumper section and door trim strips in matt black (choice of contrasting or full paint finish)



Mythos black



Wheels/tyres



Cast aluminium alloy wheels in 6-arm design size 8 J x 17



Cast aluminium alloy wheels in 5-V-spoke design size 8 J x 18 (Standard on Q5 45 TDIq)

Anti-theft wheel bolts

can only be loosened using adapter provided

Tyre repair kit

with 12V compressor and tyre sealant; permissible top speed 80 km/h

Space-saving spare wheel

including vehicle jack in the luggage compartment, permissible top speed 80 km/h

Tyre pressure loss indicator

visual and acoustic warning if the pressure drops in one or more tyres; display in the driver information system

Vehicle tool kit

in the luggage compartment

Vehicle jack

in the luggage compartment



Standard seats, front
Electrically adjustable front seats

Leather upholstery and trim



Milano leather, black

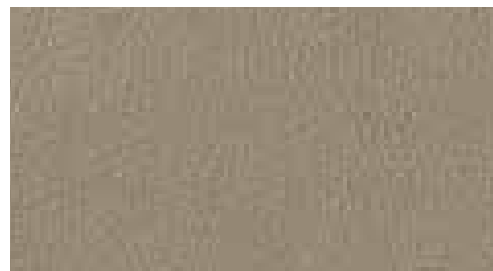

Milano leather, pistachio beige

Lights



xenon plus including headlight cleaning system

The headlights with durable gas discharge technology for dipped and high beam enable an intensive illumination of the road with evenness and range, in a colour resembling daylight both close-up and in the distance. The automatic dynamic headlight beam control prevents oncoming traffic from being dazzled; homogeneous daytime running light strip, indicators, rear and brake lights in LED technology with low power consumption

Light/rain sensor

for controlling the automatic headlights and the automatic windscreen wiper function, includes coming home/leaving home function: delayed switch-off/automatic switch-on for main headlights, rear and number plate lights when parking/opening the vehicle, includes windscreen with grey strip along the top edge

Interior lighting

with delayed switch-off and contact switches on all doors; front light with 2 additional reading lamps, rear lamps with reading lamp function, illuminated ashtray at front, glove compartment light, tailgate light, passive door reflectors, luggage compartment light, ambient lighting

Headlight cleaning system

uses water and high pressure, for excellent illumination, less scatter and good visibility

Lighting package

illuminated vents, vanity mirror lights, front and rear footwell lighting, illuminated inside door handles, active door warning lights, active entry lights, in conjunction with light/rain sensor also with left and right exterior courtesy lighting

Front fog lights

with chrome ring, integrated in the front bumper, for better illumination of the road ahead when visibility is poor

Daytime running lights

integrated in the headlights, with xenon plus daytime running light strip in homogeneous LED technology with low power consumption

Mirrors

Exterior mirrors, electrically adjustable, heated and folding, with automatic anti-glare action on both sides

Automatically dimming with light/rain sensor

for controlling the automatic headlights and the windscreen wipers; includes coming home/leaving home function: delayed switch-off/automatic switch-on of main headlights, rear and number plate lights when parking/opening the vehicle, includes windscreen with grey strip and acoustic glazing for improved windscreen insulation and reduced noise from outside

Closing systems**Central locking**

with autolock function, radio-operated remote control incorporated into the vehicle key and variable code; with one touch of the button the system opens and locks doors, windows, tailgate and tank flap, additional activation from inside on the driver's door

Glazing**Heat-insulating glass**

green tinted, windscreen made of laminated glass; rear window heated, with timer

Windscreen cleaning system

2 speeds, 4-speed adjustable intermittent wipe, touch-wipe function, automatic wash/wipe function, rear window wiper activated when reverse gear is engaged and wipes for the duration of the reversing manoeuvre (when front wipers are switched on)

Sun visors

can be folded and swivelled, on the driver and front-passenger sides, including vanity mirror

Sun visors, movable

for driver and front passenger, can be folded and swivelled, can also be moved towards the back at the side, including vanity mirror

Sunblind

for the rear door windows, manual

Electronic immobiliser

integrated in the engine control unit, automatically activated by the car key

Further exterior equipment**High-gloss package**

roof frame and window slot strips in anodised aluminium, exterior B- and C-pillar trim in high-gloss black

Roof edge spoiler**Audi Singleframe**

radiator grille in high-gloss black with vertical chrome struts

Roof system**Panoramic glass sunroof**

in 2 sections, electrical activation to raise and open the front glass section, tinted glass insert; including an electrically operated sun blind for the front and rear passengers, convenient closing from the outside via the central locking system or radio-operated remote control; ensures a comfortable interior that is flooded with light, improved interior climate by means of efficient ventilation

Further exterior equipment**Exhaust tailpipes**

flattened at the bottom, dual-branch design, 1 tailpipe each on the left and right with chrome-plated surrounds for 45 TDIq; single branch design, 1 tailpipe on the left with chrome plated surround for 30 TDIq

Seats/seating comfort**Rear seat bench plus**

with manual backrest angle adjustment, adjustable lengthways up to 100 mm to increase luggage compartment space, fold-out centre armrest with 2 cup holders, rear seat backrest can be split-folded 40:60 or fully; includes through-loading facility, remote backrest unlocking function via a lever in the luggage compartment side trim, L-shaped head restraints in the rear, manually adjustable

4-way lumbar support

electric, for driver and front-passenger seats, with horizontal and vertical adjustment

Front seats, electrically adjustable

electric adjustment for seat height, fore/aft position and seat and backrest angles, with electric 4-way lumbar support

**Centre armrest, front**

for driver and front passenger, adjustable lengthways up to 65 mm, adjustable angle, fold-open design, with storage compartment underneath the centre armrest; includes 2 cup holders and a 12V socket in the centre console

Centre armrest, rear

in the rear seat backrest, folding

ISOFIX child seat mounting for the outer rear seats

Steering wheels/gear levers/controls**Leather-covered multifunction steering wheel in 4-spoke design**

with full-size airbag, adjustable in height and reach, including gear lever knob and gear lever gaiter in leather, colour coordinated with the interior equipment selected; for operating the basic functions of Audi navigation systems, radios, voice control system, Bluetooth interface, preparation for mobile phone or car phone

Climate control

**3-zone deluxe automatic air conditioning**

with sunlight-dependent control, electronically controls the air temperature, flow rate and distribution, separate temperature distribution for driver, front-seat passenger and rear compartment, temperature and air distribution adjustable left and right in the front, control panel for setting the temperature in the rear compartment in the rear centre console, automatic recirculation mode by means of air quality sensor, front control panel features digital display, includes rain, light and humidity sensor, combined fine-dust filter, climate control of the glove compartment by means of a control knob in the glove compartment, indirect ventilation, key-coded settings

Luggage securing and storage systems

Storage package

includes storage nets on the front-seat backrests, storage compartment under the front seats, net in the front-passenger footwell, multi-fastening point in the front-passenger footwell, lockable glove compartment, luggage net on the luggage compartment floor, net underneath the parcel shelf

Cup holders

2 in the centre console between the front seats, bottle holders for storing up to four 1.5 litre bottles, located underneath the parcel shelf

Lashing points

4 in the luggage compartment, for attaching luggage and other objects, attachment points for the luggage net

Further interior equipment

**Floor mats, front and rear**

in velour, coordinated with the carpet colour

Window controls

electric front and rear, with safety system to limit closing force, one-touch open/close with convenience function

Grab handles

cushioned action, folding, four handles recessed into the roof, clothes hooks on the rear grab handles

**Centre console**

raised, with storage box and roller shutter

12V sockets

on the rear centre console and in the luggage compartment

MMI® and navigation systems

**Driver information system with colour display**

A high-resolution colour display provides you with information from the trip computer, auto check system, MMI system display items, front brake wear indicator, clock and digital speed display. The colour display is also used to indicate the current gear in vehicles with manual transmission. The integrated efficiency program assists you with consumption data overviews, display of additional consumers, enlarged current gear display and fuel-saving tips for economical driving, including attention assist

Attention assist

Part of the driver information system; the attention assist analyses driving behaviour using a range of sensors and warns if anything indicates that the driver is starting to become inattentive. Steering movements and switch/pedal actuation are recorded, for example, and compared with the individual driving patterns of the respective driver. Attention assist warns the driver by means of a display in the driver information system and an acoustic signal. The system is active from 65 km/h and can be deactivated at any time via the car menu

Centre display

with monochrome readout for ambient temperature (at temperatures below +5 °C an ice crystal symbol appears in the display to warn of possible black ice), range and radio frequency, gear selected on automatic vehicles, service indicator, oil pressure, brake fault, coolant level/temperature, brake pad wear, door-open pictogram, fuel level warning

Radio and TV systems

**Concert radio**

with CD player and SDHC memory card reader (up to 32 GB), both with MP3, WMA and AAC compatible, dynamic station list, 30-station memory, FM (VHF) and AM (MW, LW) reception, MMI operating concept, 6.5-inch TFT colour screen, TP memo function, speed-dependent volume control, phase diversity, AUX-IN connection, 8 passive loudspeakers (front and rear), total output 80 watts

Radio and TV systems



Audi sound system

6-channel amplifier, 10 speakers including centre speaker in the dashboard and subwoofer in the spare wheel well (on Q5 hybrid quattro under the loading floor), total output 180 watts

Audi music interface

for the connection of Apple iPod generation 4 and higher, Apple iPhone (music functionality) as well as USB storage media and MP3 players. The Audi music interface is located in the glove compartment and operated via MMI navigation plus, symphony radio, concert radio or a leather-covered multifunction steering wheel. Please note: can only be used in conjunction with a special adapter cable (Audi Genuine Accessories). Please contact your Audi partner or visit www.audi.com/mp3 for information on compatible MP3 players. (The separate AUX-IN connection is omitted if Audi music interface is ordered)

Preparation for Rear Seat Entertainment

includes pre-installation wiring and mounts for the holders in the driver and front-passenger seat backrests. The appropriate Rear Seat Entertainment package (tablet player with holder) is available as a plug-and-play unit from Audi Genuine Accessories

*Optional

Telephone and communication

Bluetooth interface

Bluetooth-compatible mobile phones can be connected to the vehicle via the interface. Hands-free calls are possible in the vehicle via the microphone; visit www.audi.com/bluetooth for information on compatibility

Assistance systems



Parking system plus with rearview camera*

acoustic and visual parking system for front and rear, image of area behind the vehicle shown on the MMI display, with dynamic display modes showing the calculated path (steer-angle dependent); includes switchable display with help lines and guidelines for parking in perpendicular parking spaces and identification of point at which to apply opposite lock when parallel parking, rearview camera concealed in the handle strip of the tailgate

Cruise control

at speeds of 30 km/h and above, the system keeps the set speed constant, provided that engine power and engine braking effect permit it; also features active braking intervention, e.g. when driving downhill; operated via separate steering column stalk; set speed displayed in the driver information system

Parking system plus

acoustic and visual park assist system for the front and rear with MMI screen display; measurement is by ultrasonic sensors concealed in the bumpers

Assistance systems

Auto release function

holds the vehicle stationary for unlimited periods after stopping, on almost every uphill and downhill gradient. The system is activated by push-button and allows the driver to drive away easily and comfortably without having to operate the electromechanical parking brake

Hill descent control

maintains selected speed on downhill drives

*Optional

Suspensions/brakes



Suspension with damper control*

on the basis of the standard dynamic suspension with electronically controlled adaptation to different driving situations; dynamic or comfort-oriented characteristic of the shock absorber coordination can be adapted via Audi drive select

Dynamic suspension

providing remarkable handling and exceptional comfort; 5-link lightweight front axle, tubular cross stabiliser; trapezoidal-link rear axle with independent suspension; twin-tube gas-filled shock absorbers and coil springs, front axle carrier rigidly fixed to the body, flexibly-mounted axle supports at rear

Suspensions/brakes**Brake system**

dual-circuit with diagonally-split brake system, Antilock Brake System (ABS) with Electronic Brake Force Distribution (EBD), Electronic Stabilisation Control (ESC) with roof rack detection and brake assist, tandem brake booster, disc brakes front/rear, ventilated at front

Electromechanical parking brake

includes parking brake function when stationary, drive-off assistance function through automatic release when driving away and emergency braking function whilst driving acting on all 4 wheels

Audi drive select*

changes vehicle characteristics, e.g. by adapting power steering assistance, accelerator and gear shifting characteristics, and the system also influences other optional equipment; available modes: comfort, auto, dynamic and – in conjunction with an MMI navigation system – individual

Technology/safety**Airbags****

adaptive front-end collision protection with seat position recognition and full-size airbag for driver and front passenger; side airbags at the front (thorax/pelvis airbags); head airbag system

Head airbag system

unfolds over the entire length of the side windows in the area of the 1st and 2nd row of seats and protects the passengers in the front and on the outer rear seats in the event of a side impact

Side airbags, rear

for the outer seats of the 2nd row of seats (thorax/pelvis airbags), supplement the side impact protection in the doors

Body, galvanised

fully-galvanised in areas at risk from corrosion, unitary construction, welded to the floor pan, front and rear areas feature defined crumple zones. (12 year guarantee against rust perforation)

Instrument cluster

with adjustable lighting, electronic speedometer with odometer and trip odometer, rev counter, clock coolant temperature display and fuel gauge

Safety steering column

includes a shunt mechanism with damping function to supplement the protection offered by the seat belts and airbags

Seat belts

3-point inertia reel seat belts for all seats, with belt force limiters, seat belt tensioners and belt height adjustment at front; front seat-belt reminder, colour-coordinated with the interior

Technology/safety**Warning triangle**

in the tailgate, removable

First-aid kit

in the side trim of the luggage compartment

Anti-Slip Regulation (ASR)

for good traction, reduces the spinning of the drive wheels

Electronic Differential Lock (EDL)

on surfaces with varying levels of grip, this start-off assistant automatically brakes the drive wheels on any surface that is too slippery, thereby ensuring smooth, powerful progress; operates at speeds up to approx. 100 km/h

Electronic Stabilisation Control (ESC)

with roof rack detection and offroad detection, networks the ABS, EBD, ASR and EDL with its own sensors and compares the driving data with reference data; provides better stability at all speeds by targeted braking of individual wheels and intervention in the engine management system. The system automatically detects if a roof rack is fitted and adapts the ESC accordingly

Electromechanical power steering

maintenance-free rack & pinion steering with speed-dependent power steering; precise steering feel at high speeds, assistance when parking

S tronic®

the 7-speed, electrohydraulically actuated dual-clutch transmission facilitates shorter gear changing times and gear changes with virtually no perceptible interruption in the power flow; can be operated via the selector lever. In automatic mode the driver can choose between the programs D (normal) and S (sport)

quattro®

permanent all-wheel drive with asymmetric/dynamic torque distribution, self-locking centre differential with wheel-selective torque distribution, distributes the drive force depending on the driving situation to each individual wheel for controlled handling

Recuperation: 30 TDIq & 45 TDIq

Q5: increasing the generator voltage converts kinetic energy into usable electrical energy when the vehicle is coasting or braking. This energy is used to assist the generator during subsequent acceleration – and thus allows a fuel saving of up to 3%

*optional

**The image is an illustration, not a real representation, and shows the technical state of the airbags as they deploy.

S line Package

- S line reinforced bumpers
 - S line logo in front fenders
 - Trunk sill protection in stainless steel
 - Deflector vane
 - Door sill trims with S line logo
- (Available in Q5 30 TDIq and Q5 45 TDIq Technology edition)



Look good on any road. Even where there aren't any roads.

The offroad style package emphasises the athleticism of the Audi Q5 as well as its offroad qualities. Exciting highlights make your Audi Q5 visually more robust and sportier – and almost too good-looking to take offroad!



1 Front bumper

Consisting of a bumper cover painted in body colour, radiator grille with vertical chrome struts, a spoiler painted in Stone Grey metallic and a stainless steel underbody guard.

2 Door cover strips

Painted in Stone Grey metallic. Reduce damage by e.g. stone chips.

3 Wheel arch extensions

Painted in Stone Grey, metallic. Underline the striking design of the vehicle and protect the side section.



4 Rear bumper

Rear apron, painted in Stone Grey metallic, accentuates the dynamic rear end of the Audi Q5 whilst at the same time protecting the rear underbody of the vehicle by means of a stainless steel underbody guard.

5 Running boards

Stainless steel. Make it easier, for example, to stow items in the ski or luggage box on the roof. Rubber pads reduce the risk of slipping. Each board has a load capacity of 200 kg.

A communications expert that also knows the way.

The versatile range of communications options in the Audi Q5 ensures that your favourite people and your favourite music are with you at all times. And, with the new map material for your navigation system, you might even discover a new favourite route.



1 Audi Entertainment mobile

The second generation Rear Seat Entertainment is a 9-inch screen with an integral DVD player. It is to be installed on the front seat backrests. Excellent picture quality due to the digital high-resolution screen, offers a high level of functionality and a variety of devices that can be connected to it, such as the Bluetooth headset (sold separately). The new holder for mobile end devices makes it both easy to connect and useable outside the vehicle.

Prerequisite: Rear Seat Entertainment fitting in the vehicle.

2 Adapter cables for Audi music interface

Enable connection of various iPod models and other portable media players. Operation via the MMI system, if the function is supported by the media player.



4 Rubber floor mats

Exact-fit. Offer improved protection from heavy soiling. Attached to the vehicle by means of the fastening points on the vehicle floor. With Audi Q5 logo.

5 Premium textile floor mats

Tailored to the dimensions of the Audi Q5's floor. Made from hard-wearing, densely woven velour. They are attached to the vehicle by means of additional backing and the fastening points provided in the vehicle's floor. With Q5 logo.



6 Boot liner

Custom-made protection for the luggage compartment. Washable and robust. The lip around the edge better protects the luggage compartment floor from any leaking fluids.

7 Audi child seat with ISOFIX

With adjustable seat. The seven-fold height adjustment of the belt is made with just one move of the hand. Washable fabric cover. Suitable for children from 9 to 18 kg (approximately 1 to 4 years).

Audi Q5

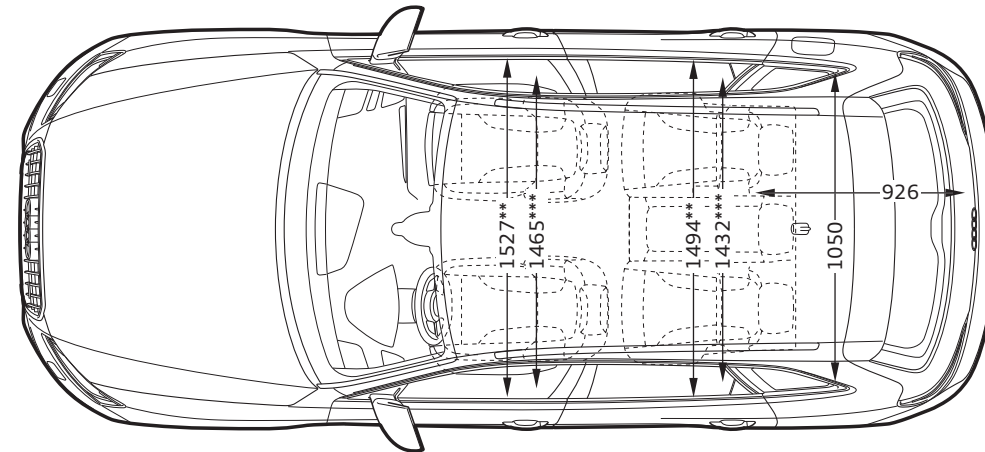
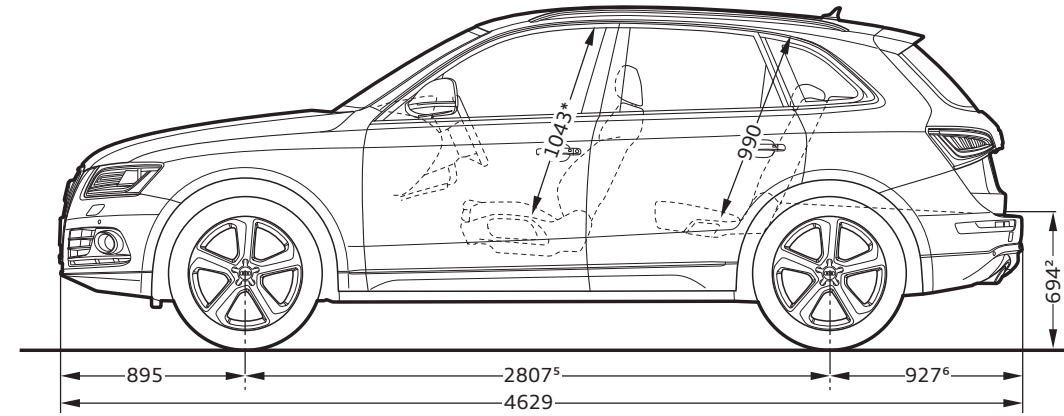
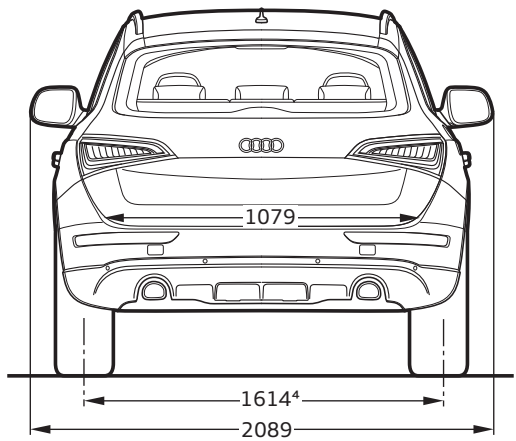
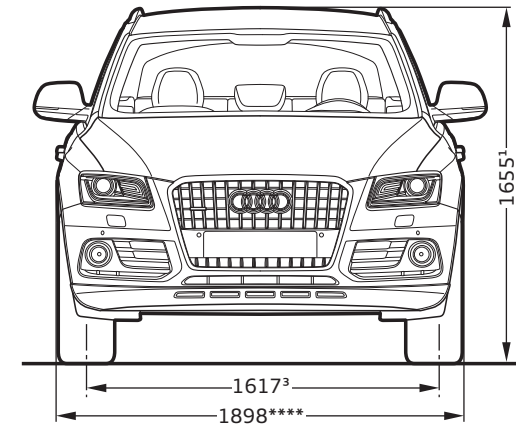

Dimensions in millimetres.

Dimensions were measured with vehicle at unladen weight.
 Luggage load area 540/1560 l for Q5 using 200 x 100 x 50 mm blocks;
 2nd value is with the rear seat backrest folded down and the vehicle loaded
 up to roof height). Turning circle approx. 11.6 m
 * Maximum headroom. ** Elbow room width. *** Shoulder room width.
 **** For Audi exclusive offroad styling package: 1911.

Equipment List Audi Q5

Code	Premium		Premium Plus		Technology Edition	
	30 TDIq	30 TDIq	30 TDIq	30 TDIq	45 TDIq	45 TDIq
Exterior						
17" alloy wheels	C4H	s	-	-	-	-
18" alloy wheels	CB5	-	s	s	s	s
Panoramic glass roof	3FU	s	s	s	s	s
Ext. mirrors electrically adjustable, heated and folding, with automatic anti-glare action	6XK	s	-	-	-	-
Ext. mirrors electrically adjustable, heated with auto anti-glare action, electrically folding with memory function	6XL	-	s	s	s	s
Xenon Plus headlights	8BP	s	s	s	s	s
Light/rain sensor	8NP	s	s	s	s	s
LED rear lights	8SK	s	s	s	s	s
Rear spoiler	5J1	s	s	s	s	s
High gloss package	4ZB	s	s	s	s	s
S line package	PQD	-	-	s	s	s
Interior						
Milano leather upholstery	N5W	s	s	s	s	s
Front seats, electrically adjustable	3L5	s	-	-	-	-
Driver's seat memory function with front seats electrically adjustable	3L4	-	s	s	s	s
Inlays, walnut dark brown	5MG	s	s	s	s	s
Leather covered multifunction steering wheel, 4-spoke design	2ZQ	s	s	s	s	s
Lighting package	QQ1	s	s	s	s	s
Interior mirror with anti-glare action	4L6	s	s	s	s	s
Storage package	QE5	s	s	s	s	s
Infotainment						
Concert radio	8UD	s	s	-	-	-
Audi music interface	UF7	s	s	s	s	s
Audi sound system	9VD	s	s	s	s	s
Bluetooth interface	9ZX	s	s	s	s	s
Preparation for RSE	9WM	s	s	s	s	s
Navigation system high	7Q1	-	-	s	s	s
DVD player	7D5	-	-	s	s	s
Radio	8AJ	-	-	s	s	s
Rear view camera	7X8	-	-	s	s	s
Voice dialogue system	QH1	-	-	s	s	s

Code	Premium		Premium Plus		Technology Edition	
	30 TDIq	30 TDIq	30 TDIq	30 TDIq	45 TDIq	45 TDIq
Comfort						
Driver information system with colour display	9Q8	s	s	s	s	s
4-way lumbar support	7P1	s	s	s	s	s
Audi parking system plus	7X4	s	s	s	s	s
Auto release function	UH2	s	s	s	s	s
Cruise control	8T1	s	s	s	s	s
3-zone automatic air conditioning	9AQ	s	s	s	s	s
Front center armrest	6E3	s	s	s	s	s
Audi drive select	2H1	-	s	s	s	s
Suspension with damping control	1BL	-	s	s	s	s
Comfort rear headrest	3Q4	-	s	s	s	s
Safety						
First aid kit with warning triangle	1T3	s	s	s	s	s
Full-size airbags & rear side airbags	4UE, 4X4	s	s	s	s	s
Tyre pressure monitoring display	7K6	s	s	s	s	s
Collapsible spare wheel	3F1	s	s	s	s	s
ISOFIX child seat mounting for the outer rear seats	3B4	s	s	s	s	s

Standard equipment S
 Optional equipment O
 Not available -
 quattro® q

Model	Audi Q5 30 TDI quattro (130 kW)	Audi Q5 45 TDI quattro (180 kW)
Engine type	4-cylinder inline diesel engine with common rail injection system and turbocharging	V6 diesel engine with common rail injection system and turbocharging
Displacement in cc (valves per cylinder)	1968 (4)	2967 (4)
Max. output ¹ in kW at rpm	130/4200	180/4000–4500
Max. torque in Nm at rpm	380/1750–2500	580/1400–3250
Power transmission/wheels		
Drive type	quattro® permanent all-wheel drive	quattro® permanent all-wheel drive
Transmission type	7-speed S tronic	7-speed S tronic
Wheels	Lightweight forged aluminium wheels, 8 J x 17	Cast aluminium alloy wheels, 8 J x 18
Tyres	235/65 R 17	235/60 R 18
Weights/capacities		
Gross vehicle weight in kg	2430	2470
Permissible roof load/nose weight in kg	75/100	75/100
Fuel tank capacity, approx. in l	75	75
Performance/consumption²		
Top speed in km/h	200	225
Acceleration 0–100 km/h in s	9.0	6.5
Fuel grade	Sulphur-free diesel ³	Sulphur-free diesel ³
Fuel consumption ⁴ in km/l	14.16 km/l	13.22 km/l
CO ₂ emission ⁴ in g/km	urban extra-urban combined	[187] [159] [169]
Emission standard	EU5	EU5

Notes

¹ The figure given was calculated using the specified measuring procedure (current version of Directive 80/1269/EEC).

² A vehicle's fuel consumption and CO₂ emissions do not just depend on how efficiently the vehicle uses the fuel, but are also influenced by driving behaviour and other non-technical factors. CO₂ is the greenhouse gas primarily responsible for global warming.

³ We recommend using sulphur-free diesel in accordance with DIN EN 590. If not available, use diesel in accordance with DIN EN 590.

⁴ The values stated were calculated using specified measuring procedures as per Bharat Stage IV by the ARAI.

Important note

Inspections are due as shown by the service display.

