



FALL HOME +GARDEN SHOWSM

August 28 & 29, 2021

This Exhibitor Manual has been compiled to help you and your staff with complete details about all phases of the exhibition process at the Fall Home + Garden Show.

Enclosed you will find helpful information to make your participation in our show successful.

We strongly urge that you give this manual to each staff member responsible for your participation in the Show.

GENERAL INFORMATION

SHOW MANAGEMENT

The Fall Home + Garden Show is produced and managed by:

Huntsville Madison County Builders Association

Huntsville, Alabama 35805

Event Director: Theresa Kennedy | 256.536.2602 | theresa@hmcba.org

SHOW FACILITY

The Fall Home + Garden Show is held at:

South Hall, Von Braun Center

700 Monroe Street

Huntsville, Alabama 35801

ORDER SERVICES FOR THE SHOW - VBC

Booth furnishings: rental of tables, chairs, booth carpeting, banner hanging, electric, labor, etc.

VBC Decorating Department

Phone: 256.551.2239

Fax: 256.551.2221

decorating@vonbrauncenter.com

ADVANCE ORDER DISCOUNT DEADLINE: August 19, 2021

WEBSITES

HuntsvilleHomeShows.com

HMCBA.org

WeBuildNorthAlabama.com

SHOW DATES & HOURS:

Saturday, August 28th • 10:00 am - 6:00pm

Sunday, August 29th • 12:00 pm - 5:00pm

GENERAL INFORMATION

HOSPITALITY ROOM

DATES & TIMES:

Saturday, August 29th - 9:00 am - 5:00 pm

Sunday, August 30th - 10:00 am - 4:00 pm

The Hospitality Room is located in the South Hall Lobby in Meeting Room 3 which is also our Show Office.

There will be water, limited coffee and snacks available. .

EMERGENCY INFORMATION

In the event of a medical emergency, you should proceed directly to the Show Office (located across the foyer from the South Exhibit Hall). Appropriate authorities will be contacted immediately.

EXHIBITOR BADGE PICK UP

Badge pick up will take place at the Show Office during move in at the VBC.

Badges cannot be used by anyone other than exhibitors. They display the company name and booth number and are interchangeable amongst your staff. You are welcome to leave badges for your staff members in the Show Office for pick up. Additional badges are available for \$5 each.

Badges are available to pick up during the following times:

Thursday, August 26, 1pm - 4pm

Friday, August 27, 8am - 4pm

DISCOUNT TICKETS

Discounted tickets to the show are available by filling out the Discount Ticket form before the show or by visiting the Show Office during the show. These are great to give to your customers!

COMPLIMENTARY TICKETS

All exhibitors will receive a total of 6 complimentary tickets. .

COMPLIMENTARY TICKETS ARE NOT PERMITTED TO BE DISTRIBUTED AT THE ENTRANCE TO THE SHOW.

Use your tickets to invite potential customers to the show, as a thank you to good customers and for friends and family.

WILL CALL

Will Call will be located in the Show Office. You are welcome to leave tickets for customers at will call. Please leave your tickets in INDIVIDUALLY marked envelopes with FIRST AND LAST NAME for your guests.

VEHICLES IN EXHIBITS

If you plan on having a vehicle in your booth as part of your display, please contact Show Management for move-in instructions.

°All vehicles must have a locking gas cap or gas cap sealed with tape and no more than 1/4 tank of gas in the vehicle in accordance with the Indiana State Fire Marshal.

°A set of keys must be left with Show Management for the duration of the show.

°All vehicle batteries must be disconnected, and cables taped.

SECURITY

Show Management provides 24 hour security for the show floor during move-in, move-out, show hours and overnight. However, neither Show Management nor the VBC is responsible for lost, damaged or stolen articles.

Report anything of a suspicious nature to Show Management and/or Security.

LIABILITY INSURANCE CERTIFICATE

Liability Insurance Certificate must be turned in PRIOR to move-in. You cannot move in without this document on file. Certificate must name both the Von Braun Center (700 Monroe St. Huntsville, AL 35801) and the Huntsville Madison County Builders Association (2804 Bob Wallace Ave. Huntsville, AL 35805) as additional insured certificate holders for the specified dates of Aug. 26 - 30, 2021. Have your insurance agency forward this to theresa@hmcba.org This is due August 6.

DEADLINES & REMINDERS

July 20 - Balances Must be Paid in Full

Aug.6 - Insurance Certificate

Aug. 19 - VBC Order Discount Deadline

Aug. 23 - Hanging Banners Delivered to VBC by Noon

Aug. 26-27 - Badge Pick-Up @ Show Office (VBC)

SMOKING REGULATIONS

No smoking is permitted inside any building at the Von Braun Center.

SALE OF MERCHANDISE AT THE SHOW

All Exhibitors are reminded that to sell products "cash and carry" during the show, you must comply with all rules and regulations of the Show. Exhibitors are responsible for obtaining any permits as required. Only merchandise approved by the show may be sold.

ANIMALS/PETS

Service animals are allowed inside the building during event hours of the event. Personal pets are not allowed.

MOVE-IN | MOVE-OUT DAYS AND HOURS

MOVE-IN DATES & TIMES

August 26 (Thursday) - 8:00 am until 5:00 pm

August 27 (Friday) - 8:00 am until 4:00 pm

EACH EXHIBITOR WILL HAVE AN ASSIGNED MOVE IN & MOVE OUT TIME. THIS WILL BE SENT VIA EMAIL CLOSER TO THE SHOW. PLEASE DO NOT ARRIVE BEFORE YOUR ASSIGNED TIME.

Set up may continue after 5:00 pm on Thursday. However, vehicle traffic will end at 4:30 pm. Once you leave the building, you can not re-enter. All booths must be completely set-up by 4pm on Friday.

No vehicles on the floor on Friday.

NO EXHIBITOR WILL BE ALLOWED TO MOVE IN UNLESS THE HMCBA HAS RECEIVED FULL PAYMENT AND CERTIFICATE OF LIABILITY INSURANCE!]

Exhibitors are responsible for cleaning up any debris, tape, etc. which may be used during booth set-up. This must be cleaned up by 4:00 pm Friday, August 27. The use of Guerrilla Glue, paint & other toxic items are not permitted.

Booth Inspections - The HMCBA will make an inspection of each booth during the course of Move-In as well as final inspections on Friday, Aug 27. The HMCBA reserves the right to move/modify exhibits or portions thereof, which in the discretion of the HMCBA are deemed objectionable, in poor taste, or do not meet booth requirements. Failure of the exhibitor to make changes as directed by the HMCBA as soon as notified will result in the removal of the exhibit, or portions thereof, by the Show Management. Any costs incurred will be at the expense of the exhibitor.

CONSTRUCTION DURING MOVE-IN

No cutting or sawing of any kind is allowed in the South Hall. Please fabricate your booth offsite.

No mixing of any substrate is allowed in the South Hall. Anything causing “dust” or debris is not allowed inside the South Hall. There is a designated outside for cutting.

PLEASE NOTE:

Please be advised that you may not be able to drive your vehicle directly to your booth at any given time, even during your designated move-in or move out time.

You are not allowed to build or setup your booth from your vehicle. Booth contents must be unloaded in your booth and not block the aisleway. After quickly unloading, you must remove your vehicle from the building immediately.

MOVE-IN | MOVE-OUT DAYS AND HOURS

MOVE-OUT DATES & TIMES

August 29 (Sunday) - 5:30 pm until 7:00 pm

August 30 (Monday) - 8:00 am until 5:00 pm

EACH EXHIBITOR WILL HAVE AN ASSIGNED MOVE IN & MOVE OUT TIME. THIS WILL BE SENT VIA EMAIL CLOSER TO THE SHOW. PLEASE DO NOT ARRIVE BEFORE YOUR ASSIGNED TIME.

No items can be removed from your booth area prior to 5:30 pm on Sunday, August 29! ***

No vehicles will have access into the South hall on Sunday, August 29; please hand carry items. (NO vehicles will be allowed to line up at the freight doors and loading docks prior to 5:00 pm on Sunday, August 29)

As soon as the building is vacated by the general public, an announcement will be made by Show Management and you can begin carrying out your items.

For security reasons, it is recommended that all items which can be hand-carried be taken from the building Sunday night.

All items must be removed from the South Hall by 5:00 pm on Monday, August 30. Any items left will be forfeited to the VBC. The exhibitor may incur sanctions from the HMCBA including being barred from participating in future Shows and other penalties as deemed appropriate by Show Management. Exhibitors may also incur charges from the VBC for Exhibit Removal.

PLEASE NOTE:

Please be advised that you may not be able to drive your vehicle directly to your booth at any given time, even during your designated move-in or move out time.

Your booth must be torn down and ready to load in your vehicle before driving on the show floor. Booth contents must not block the aisleway. After quickly loading, you must remove your vehicle from the building immediately.

PARKING INFORMATION

NO PARKING BEHIND SOUTH HALL AT ANY TIME. The South Hall parking garage will be open during move-in / move-out at no expense. This parking garage has a low clearance (7'7") – No large trucks, vans, vehicles with racks on top, **NO TRAILERS!**

During move in and move out, vehicles will be asked to wait in our staging area, which is the former Meadow Gold lot. There is no parking in the lot (Lot V) - you must remain with your vehicle while you wait for access to the show floor. All vehicles must be removed from this lot by 6pm each day and no vehicles can park here during the Show. Any vehicle that parks there will be towed at owners expense.

LARGE VEHICLE PARKING DURING MOVE-IN/MOVE-OUT. Larger vehicles will NOT have a place for designated parking during move-in / move-out in Lot K. If you have a vehicle larger than 7' – 7", we will need to coordinate parking for you during move in.

Neither the VBC or the HMCBA will be held responsible for any damage or missing items.

DIRECTIONS

From I-65 (North or South), take Exit 340 to Huntsville I-565 headed East. Travel approximately 19 miles to exit 19-C to Washington Street. Turn right on Washington Street, cross over the bridge to the first traffic light - Monroe Street. Turn right onto Monroe Street and travel to the 3rd traffic light (Clinton Avenue). To reach the South Hall Parking Garage, turn right (west) on Clinton Avenue from Monroe Street. Continue to the next traffic light and turn left on Pollard Avenue to access the South Hall Parking Garage.

MAP OF VBC

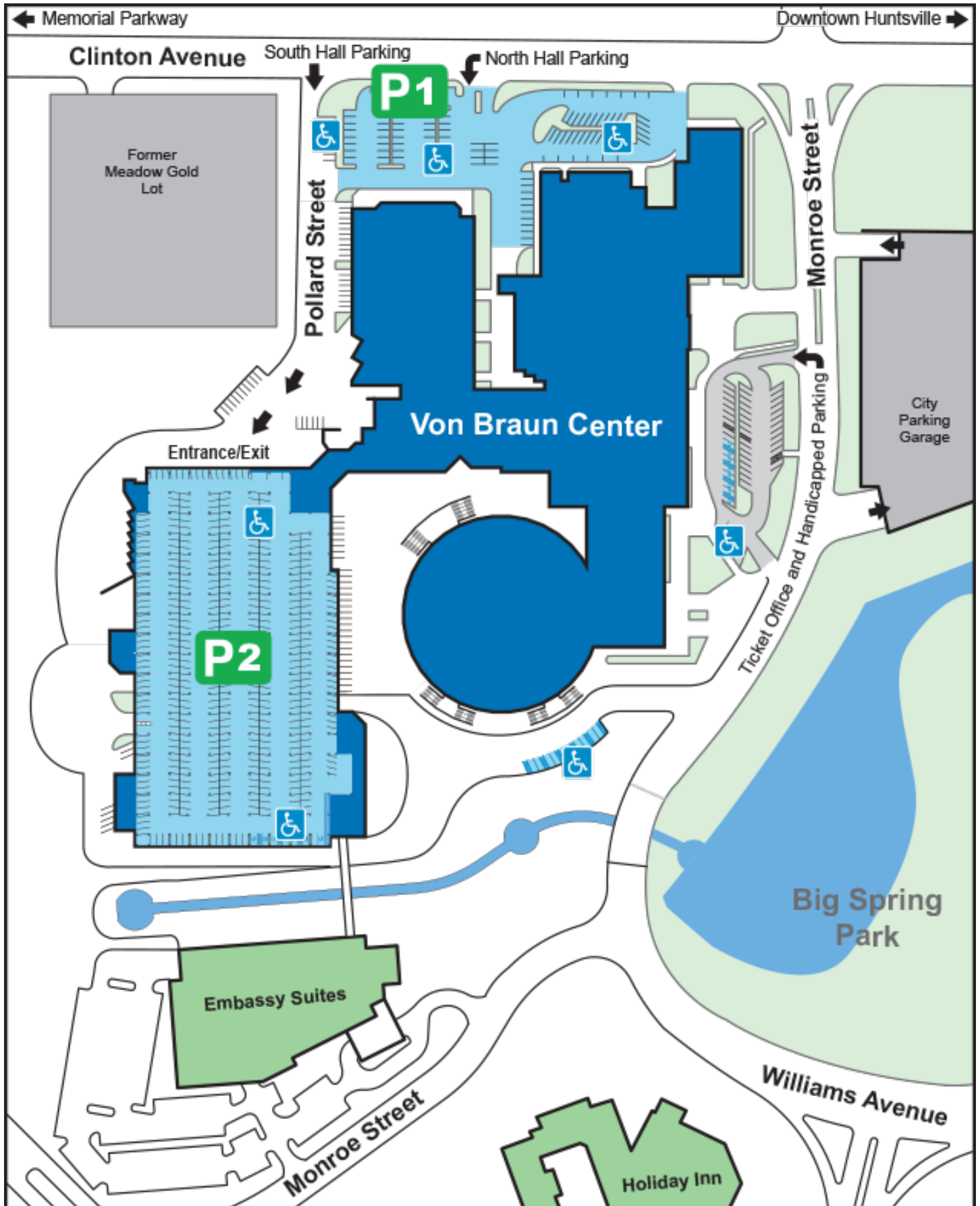

BOOTH INFORMATION & REGULATIONS

Exhibit booths will have an 8' draped back wall. On each side, a draped side rail will extend from the back of the booth to the front of the booth at a height of 3'. Drape color is black.

PLEASE NOTE: TENTS ARE NOT ALLOWED OF ANY KIND AS A PART OF YOUR DISPLAY

STAFFING YOUR BOOTH

All exhibitors are expected to be in their booths during all published show hours, as we do receive consumer complaints about un-manned displays. Our visitors pay an entrance fee and expect to be able to do business with our exhibitors at any time during show hours. If you are in violation of this rule, your company may not be permitted to exhibit with us in the future.

DEMONSTRATIONS AND HANDOUTS

Exhibitors demonstrating products and/or distributing marketing materials, or product samples are not permitted to do outside the confines of their rented exhibit area. Working in the aisle is strictly prohibited and will be enforced by show management. This includes any mascots.

SIDES & BACK OF BOOTH

Sides & Back of Booth - The sides of each booth cannot exceed 4 feet high and may not extend more than 5 feet from the back wall unless approved otherwise prior to setup. Display fixtures over 4 feet in height must be confined to the back half of the booth. Sides and back of booth must be "finished" if visible to the public. Display panel backing over 8 feet in height may not bear the exhibitors logo or any other commercial markings that might infringe upon adjacent exhibits. The exhibit must fit within the confines of the booth space and cannot extend into adjoining booths or aisles or disturb booth drapes.



BOOTH INFORMATION & REGULATIONS

SIGNS & BANNERS IN BOOTH

All booths must be clearly identified with your company name. Small signs will be provided for each booth.
No electronic signs permitted

HANGING SIGNS & BANNERS ABOVE YOUR BOOTH

- *Must be professionally made.
- *Must be CLEAN and presentable on BOTH SIDES.
- *Must be SEWN not glued.
- *Must have a metal grommet every 3 feet.
- *Must be 2' shorter than the width of your booth with a maximum of 5' in height.
- *Will not be hung lower than 14' from floor
- * Plan to bring your banner to the Von Braun Center prior to move-in beginning August 17 at 10am.

Banners delivered prior to the 21st will receive priority hanging on Thursday, Aug. 27th, as time allows. The VBC does not guarantee that all banners will be in place prior to your scheduled move in time however providing all supplies and information prior to the event allows the VBC to staff appropriately. Please call Lauryn with any questions at 256-551-2237. BANNER DELIVERY DEADLINE IS NOON, AUGUST 23. Clearly mark name of company and booth on outside of banner along with name & phone number.

Due to the large number of banners, no guarantee is made that your banner will be visible on both sides (if double sided) or that will be visible from any specific point on the show floor.

SMOKE / FOG-MACHINES

Smoke / fog-producing machines may not be used at any time.

GIVEAWAYS

No sound making devices may be given away during the Show. Exhibitors are encouraged to give away door prizes during public admission days.

SOLICITING, CATALOGS, SOUVENIRS, ETC.

Soliciting, polling, interviewing, etc. in any part of the VBC other than Exhibitor's booth is strictly prohibited.

BOOTH INFORMATION & REGULATIONS

FOOD & BEVERAGES

All food and beverages must be sample size only.

GLUE

No Guerilla Glue is to be used on the floors or walls of the VBC. .

COVERED EXHIBITS

Fire extinguishers are required for all covered exhibits
(10 lb ABC, must be tied off & visible)

NO TENTS

HELIUM TANKS

- ° Helium tanks are permitted but must have protective valve covers.
- ° 30+ lb tanks must be anchored to a permanent structure such as a wall of the VBC
- ° Small table top tanks are fine as stand alone

MACHINERY

Any machine with an engine that will remain inside the VBC MUST:

- ° Have less than quarter tank of gas
- ° Have plastic under engine
- ° Leave the keys on site with VBC Security
- ° Machinery with movable parts must have adequate safeguards to protect the public

SOUND EQUIPMENT, MUSIC & PRODUCT DEMOS

Must be kept at conversational level. Do not block aisles with product demonstrations.
All activities must be confined to the limits of the exhibitor's booth.

BOOTH CONSTRUCTION

Standard exhibit configuration is 10' square and multiple's thereof. - The sides of each booth cannot exceed 4 feet high and may not extend more than 5 feet from the back wall unless approved otherwise prior to set-up. Display fixtures over 4 feet in height must be confined to the back half of the booth. Sides and back of booth must be "finished" if visible to the public. Display panel backing over 8 feet in height may not bear the exhibitors logo or any other commercial markings that might infringe upon adjacent exhibits. The exhibit must fit within the confines of the booth space and cannot extend into adjoining booths or aisles or disturb booth drapes.

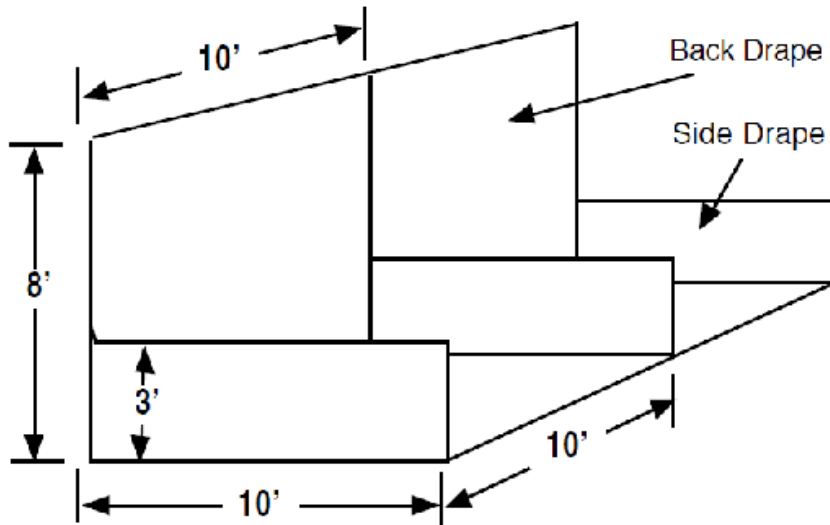

Empty booth prior to exhibitor setup

These are examples of standard 10x10 exhibit booths erected prior to exhibitor setup.

Three foot side drapes may only be removed from the end of a row, next to an aisle.

Please request side drape removal at the Show Office and the show decorator will gladly help you.

Exhibitor booth setup guidelines

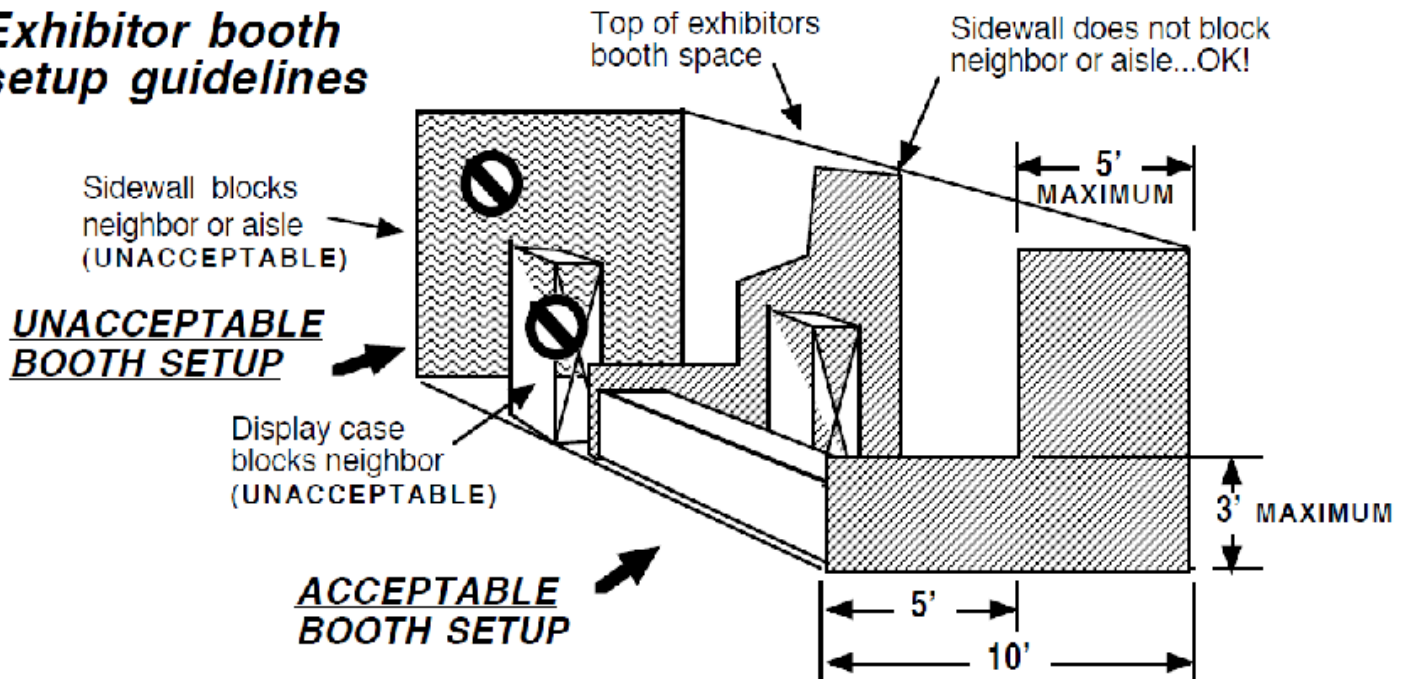

Dimensions and Use of Space- Linear Booth (Diagram Below)

Linear Booths, also called "in-line" booths, are generally arranged in a straight line and have neighboring exhibitors on their immediate right and left, leaving only one side exposed to the aisle. Regardless of the number of Linear Booths utilized, e.g. 10ft by 20ft, 10ft by 30ft, 10ft by 40ft, etc. display materials should be arranged in such a manner so as not to obstruct sight lines of neighboring exhibitors. The maximum height of 8ft is allowed only in the rear half of the booth space, with a 4ft height restriction imposed on all materials in the remaining space forward to the aisle.

NOTE: Your pipe and drape will consist of a 10ft wide X 8ft tall (wider for multi inline booths) pipe and drape on your back wall and 3ft tall X 10ft long side pipe and drape for your side walls. The model below shows the area in which you can build in regards to the line of sight. There are not 8' tall X 5' wide walls pre-built into the booth.

Please contact Theresa Kennedy with any questions regarding booth set up at 256.536.2602 or via email at theresa@hmcba.org.

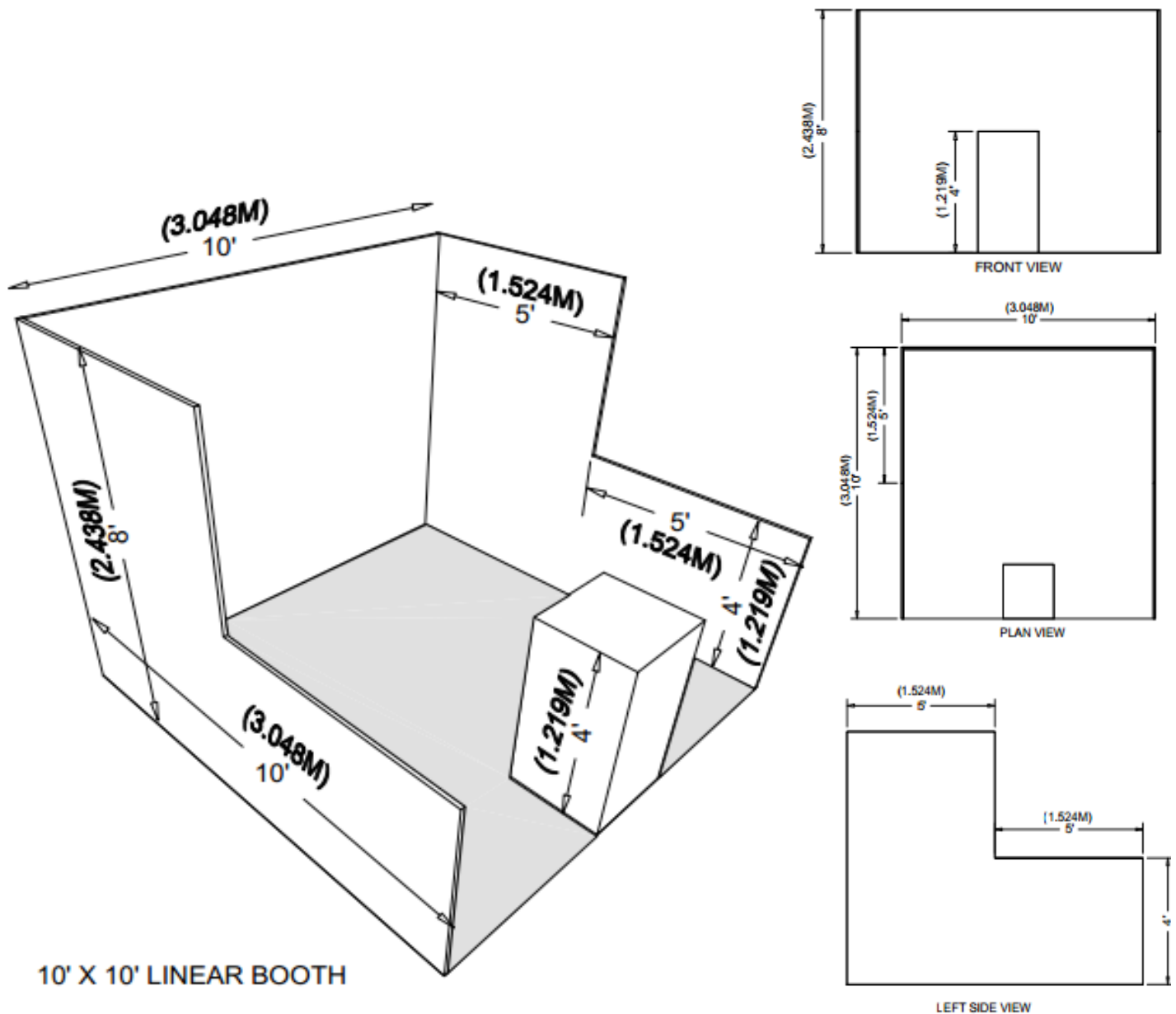

Dimensions and Use of Space- Peninsula Booth (Diagram Below)

A Peninsula Booth is exposed to aisles on three sides, and comprised of a minimum of four booths. There are two types of Peninsula Booths: (a) one which backs to Linear Booths, and (b) one which backs to another Peninsula Booth and is referred to as a "Split Island Booth." Dimensions A Peninsula Booth is usually 20ft by 20ft or larger. When a Peninsula Booth backs up to two Linear Booths, the back wall is restricted to 4ft high within 5ft of each aisle, permitting adequate line of sight for the adjoining Linear Booths.

Please contact Theresa Kennedy with any questions regarding booth set up at 256.536.2602 or via email at theresa@hmcba.org.

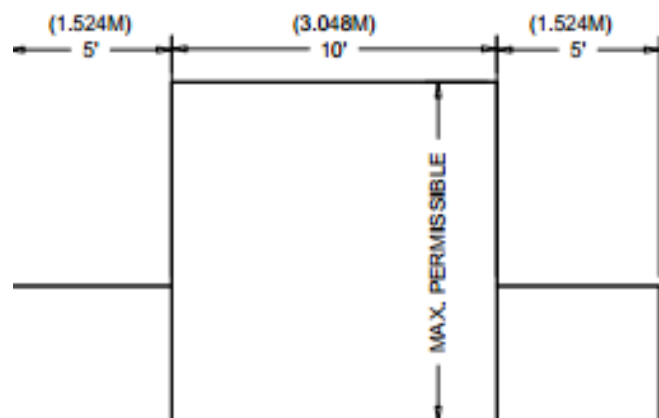
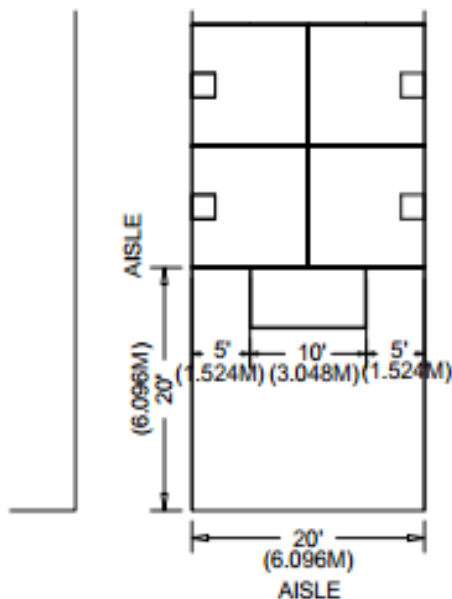
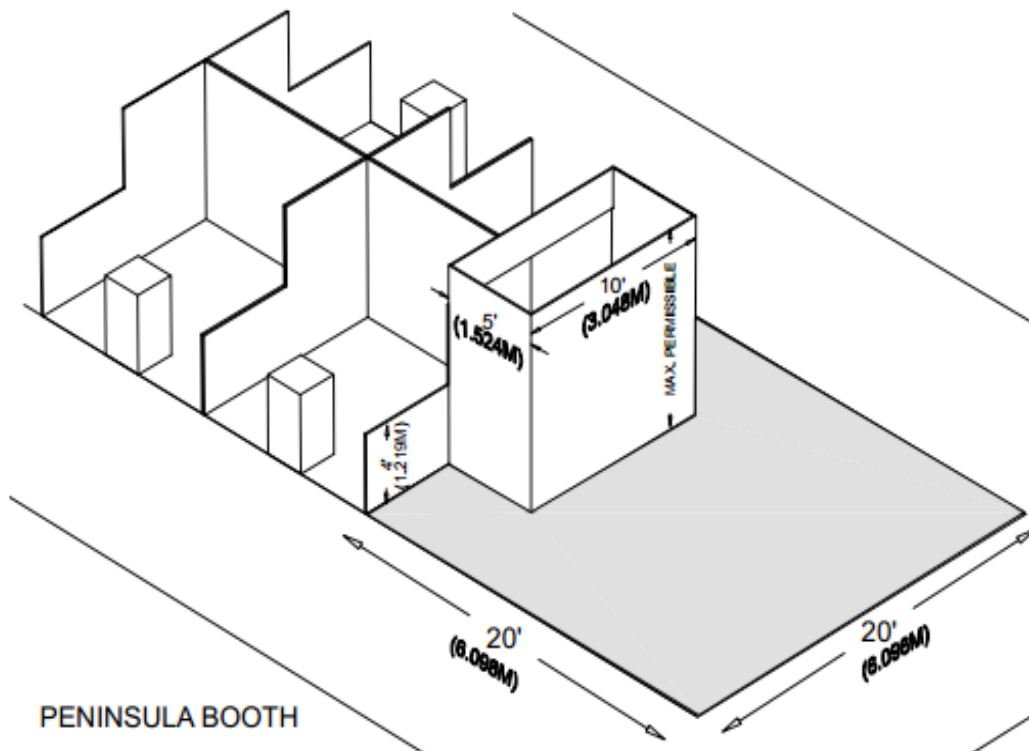

Dimensions and Use of Space- Island Booth (Diagram Below)

An Island Booth is any size booth exposed to aisles on all four sides.

Dimensions - An Island Booth is typically 20ft by 20ft or larger, although it may be configured differently.

Please contact Theresa Kennedy with any questions regarding booth set up at 256.536.2602 or via email at theresa@hmcba.org.

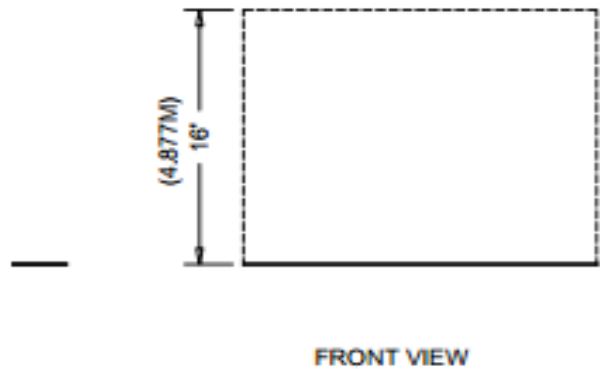
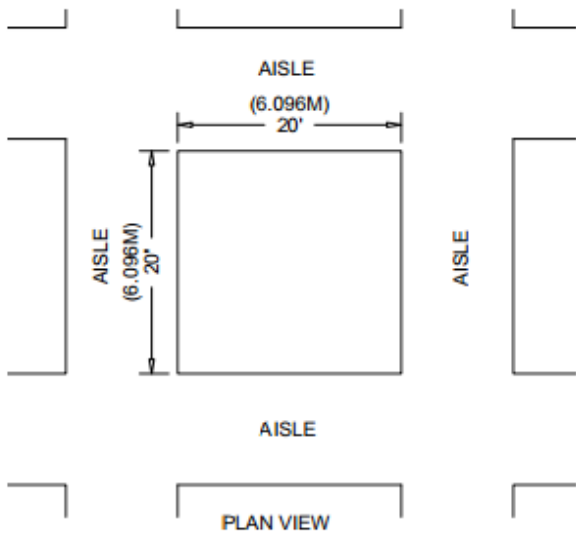
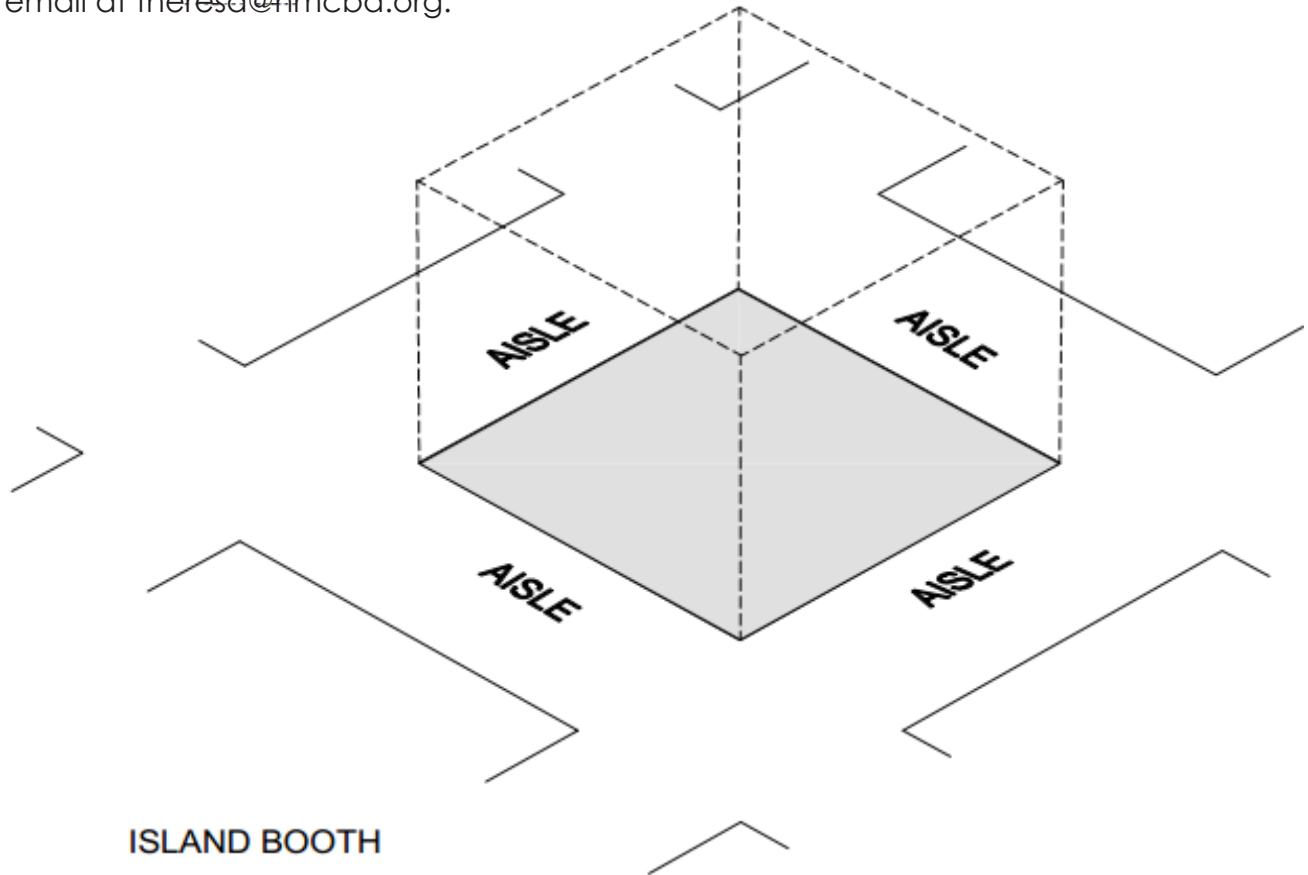

Dimensions and Use of Space- End Cap (Diagram Below)

An End-cap Booth is exposed to aisles on three sides and composed of two booths. End-cap Booths are 10ft deep by 20ft wide. The maximum back wall height of 8ft is allowed only on a 10ft portion that is adjacent to neighboring "in-line" booths. This portion will be centered along the back wall which is 5ft from either aisle. You are allowed to build to a maximum height of 4ft at the two 5ft wings- so as to not block the line of sight for the booth behind your end cap layout. There is a 4ft height restriction imposed on all materials in the remaining space forward to the aisle.

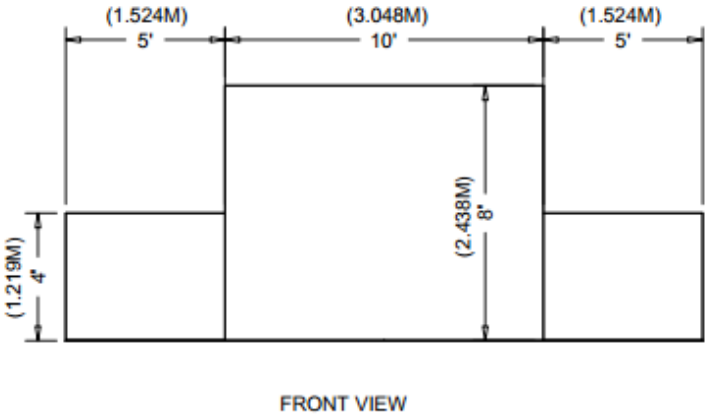
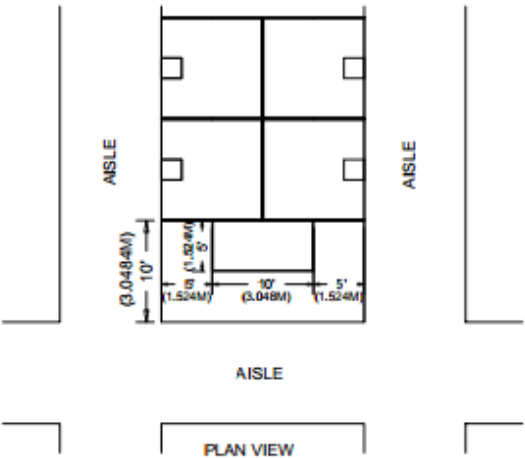
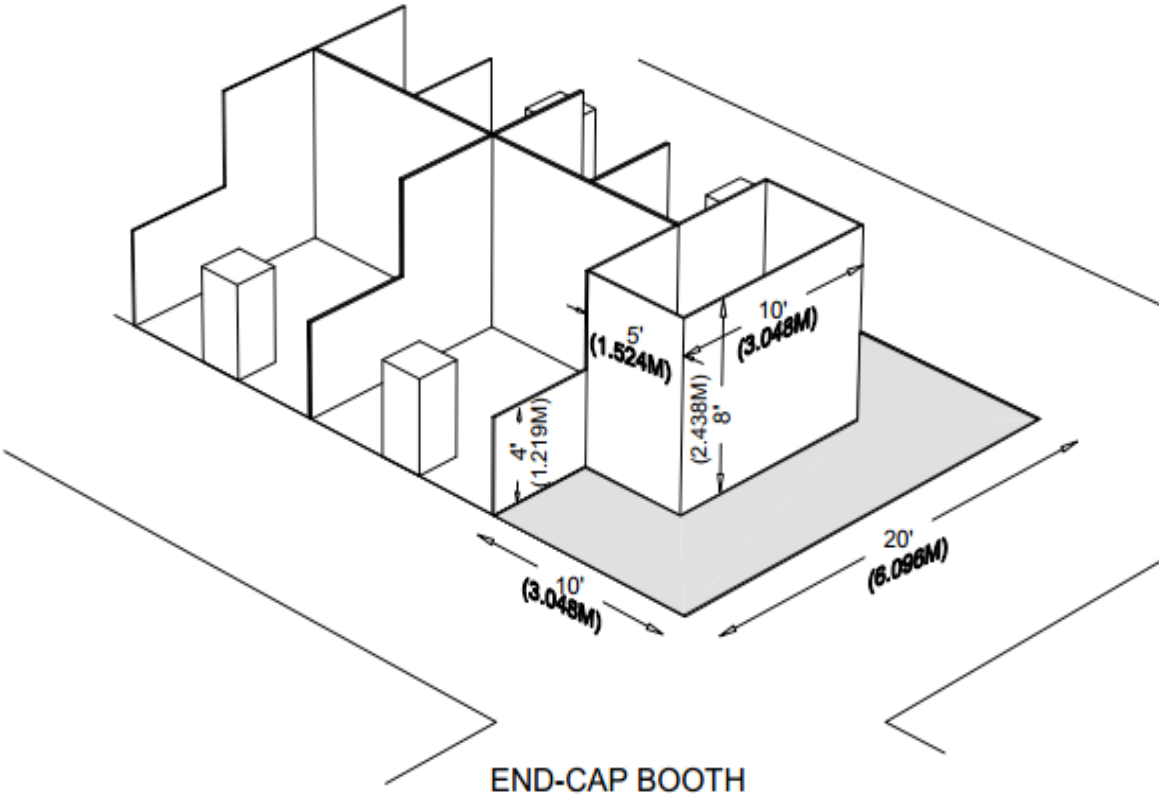

If you have questions about setting up your booth, please contact Theresa Kennedy at 256.536.2602 or via email at theresa@hmcba.org.

NOTES



FALL HOME +GARDEN SHOWSM

August 28 & 29, 2021

HMCBA 
HUNTSVILLE MADISON COUNTY
BUILDERS ASSOCIATION