

AV Solutions for Instructional Spaces



Extron

Extron is Committed to Education



Every day, thousands of students and instructors around the world are having their educational experiences enhanced by Extron audiovisual signal processing, distribution, and control products. Our advanced technologies create better looking images, higher quality sound, and systems that are easier to control and work more reliably. We are continuing to develop solutions that meet the unique performance and value requirements of the education market.

S3 Education Partnership Program

Extron's commitment to the education market extends beyond our industry leading technologies and products. We also strive to provide comprehensive support, training, and other benefits which has led to this new partnership program created exclusively for our education customers.

Key Program Benefits:

- ▶ Discount Pricing for Education Customers
- ▶ Industry Leading Technical Support
- ▶ Technical Design Assistance
- ▶ Training & Certification
- ▶ Extron Insider Website Access
- ▶ Extron 5 Year Product Warranty
- ▶ Product Demonstrations & Evaluation Equipment
- ▶ Contractor Recommendations

Advanced Switching

Scaling, Matrix Switching, AV over IP, Videowall



Certain locations on campus have more advanced audio, video, and control requirements than the typical classroom. These include lecture halls, multipurpose rooms, performance spaces, libraries and more. As outlined below, Extron offers a wide array of solutions to address even the most complex learning environment.

Scaling and Matrix Switching

Extron's advanced scaling technology accepts signals from a wide range of sources and processes them for optimal image quality on any display. Our Vector 4K scaling engine employs advanced algorithms for upscaling and downscaling, ensuring that critical image detail is maintained. Matrix switchers provide the ability to route any input to any output or to multiple outputs at any time. They accept AV signals from a range of input sources including computers, laptops, tablets, cameras, and Blu-ray players, and route the output to different destinations, such as projectors, flat panel displays, and video conference codecs.

AV over IP

Extron created NAV™ as the only no-compromise Pro AV over IP solution for distribution and switching of ultra-low latency, high quality video and audio signals over an Ethernet network at low bitrates. Utilizing Extron's patented PURE3® codec, it delivers groundbreaking performance with visually lossless video over IP at resolutions up to 4K @ 60 Hz with 4:4:4 chroma sampling. The NAV Series is the only solution that offers both 1 Gbps and 10 Gbps encoders and decoders while providing full interoperability across both systems.



Videowalls

Extron offers multiple videowall solutions including the industry-leading Quantum® Series of processors. They provide scalability for applications ranging from small retail displays up to large command and control facilities. Quantum Ultra is a 4K videowall processor that features Vector 4K scaling, high-performance windowing, future-ready HyperLane® video bus, and modular architecture to accommodate any source and display requirements.

Advanced Control

Keypad Controllers, Touchpanels, Room Scheduling

MediaLink Plus

The Extron MediaLink Plus Series are easy-to-use keypad controllers used for common AV functions such as power, input selection, and volume. They feature a variety of RS-232, relay, IR and digital input ports making them ideal for single display applications. Ethernet monitoring and control allows users to manage, monitor, and control AV devices over a standard Ethernet network. PoE provides power and communications over a single Ethernet cable.



MLC Plus 84 EU



TLP Pro 1025M

TouchLink Pro Control Systems

For more sophisticated applications, a touchpanel may be the best choice for AV control. The Extron TouchLink Pro family of customizable touchpanels range in size from 3.5" up to 17", and are available in a variety of mounting options including tabletop, wall mount, and flip-up Cable Cubby enclosures. Several models feature vibrant, capacitive touchscreens with edge-to-edge glass, and a multisource, high-resolution video preview.

Room Scheduling

We have simplified the room booking experience with Extron Room Scheduling. This stand-alone system consists of elegantly-designed TouchLink® Scheduling Panels that connect directly to Microsoft® Exchange, Office 365™, Google Calendar™, 25Live®, or EMS®. Users can make on-demand reservations from the touchpanel, a computer, or their mobile device. Free Room Agent software makes setup a breeze, allowing you to customize the touchpanel interface with the meeting options you need. Multiple touchpanel mounting options are available including on-wall and in-wall, as well as secure mounting to almost any flat surface, including glass or granite.



Collaboration Systems

TeamWork, ShareLink, Unified Communications

TeamWork® Connect expands Extron's popular TeamWork family with a powerful, cost-effective collaboration solution for education applications. With the addition of meeting space collaboration systems such as the HC 404, switching, scaling, signal extension, and control functions are combined into one solution. TeamWork systems are simple to deploy and intuitive to use. Just connect a laptop or tablet to a TeamWork Show Me® cable to start the system, and then press the Share button to display content on the presentation display. When done, simply disconnect the devices and the system automatically powers down.

ShareLink™ is a collaboration gateway for sharing content from computers, smartphones, and tablets. It can be used to create a stand-alone wired or wireless collaboration and presentation system or to add wireless presentation capabilities to an existing classroom AV system. ShareLink technology supports simultaneous sharing of images, documents, or applications from up to four devices. It is compatible with Windows® and OS X® computers as well as Apple® and Android™ smartphones and tablets. ShareLink also includes a moderator mode allowing the instructor to ensure only approved content is displayed.

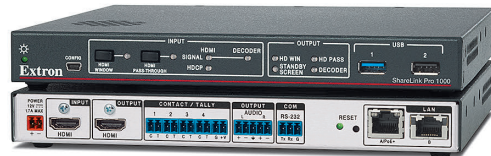

ShareLink Pro 1000

ShareLink technology supports simultaneous sharing of images, documents, or applications from up to four devices. It is compatible with Windows® and OS X® computers as well as Apple® and Android™ smartphones and tablets. ShareLink also includes a moderator mode allowing the instructor to ensure only approved content is displayed.

Unified Communications

Extron has developed technology to integrate with the leading unified communication solution providers, creating a one-touch user experience for conferencing, collaboration, and control. Through our partnerships, we can extend Extron control capabilities to spaces that use Zoom, Cisco, Logitech, and many other popular providers. We offer complete system integration for convenient, centralized control of conferencing systems, audio, video, lighting, window shades, and much more.

zoom

logitech

cisco

DOLBY



Streaming AV

H.264 Capture, Encoding, and Decoding

Extron **StudioStation**® is a quick, simple, and convenient solution for one-touch recording of high quality video and audio presentations. To turn the system on, insert a USB stick and press the record button to begin recording. StudioStation solutions are ideal for flipped classroom recordings, student assessments, rehearsal spaces, moot courts, or any other application where making a recording by pressing only one button is desired.

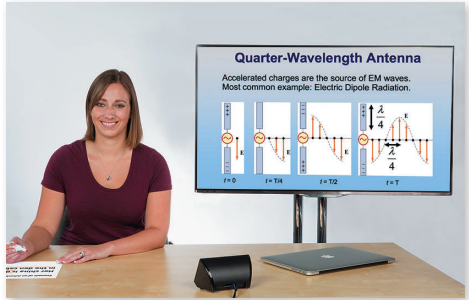

The **SMP 300 Series** of products are high performance H.264 streaming media processors for capturing and distributing AV sources and presentations as live streaming and recorded media. Accepting HDMI, component, composite, and optional 3G-SDI signals, these processors are able to record and stream simultaneously. They can stream at two different resolutions and bit rates concurrently using a range of transport protocols and session management options.

The **SMD 101** and **SMD 202** are compact, high performance H.264 decoders that create complete end-to-end streaming systems when used with Extron SMP and SME encoders. Both units provide advanced signal processing, scaling, and aspect ratio management that supply high quality signals to AV displays. In addition to live stream decoding, the SMD 202 also offers the flexibility to playback media files from internal memory, a removable SD memory card, or a locally connected USB storage device.

Extron streaming products can be used for a variety of education AV applications including:

- Lecture capture for flipped classrooms
- Campus-wide distribution of student news, CATV, or DVD content
- Overflow presentation of athletic, theater, graduation, and other events
- Digital signage

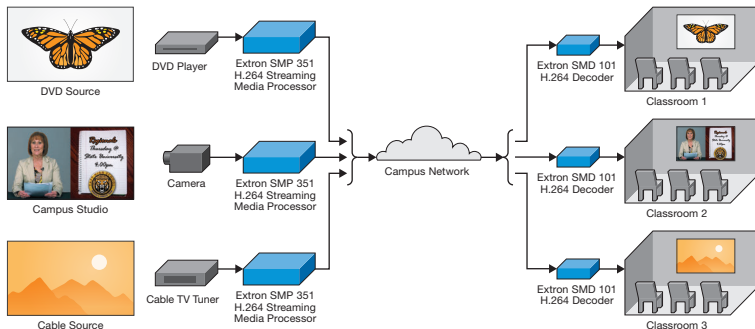

Audio Products

Speakers, Amplifiers, DSP

Extron manufactures audio products for almost any educational application, from classrooms and lecture halls to distance learning and conferencing. With such a wide array of design, performance, and form factor options, we are sure to have a solution that meets your audio requirements.

Speakers

Extron speakers are designed to provide exceptional sound quality and coverage for speech reinforcement and program audio applications. Pendant, soundbar, ceiling, and surface mount options are available to complement any environment. Ceiling speakers equipped with Extron patented Flat Field® Technology provide extraordinarily wide dispersion for consistent sound levels across the listening area, reducing the number of speakers required in rooms with low ceilings.

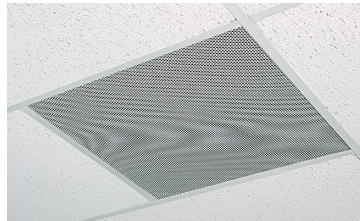

FF 220T Full-Range Flat Field Speaker

Amplifiers

Extron Power Amplifiers are ideal for space constrained locations and may be mounted in a small rack, within a credenza, within a lectern, above a drop ceiling, or behind a display. Our XPA Ultra Series of power amplifiers offering 2, 4, or 8 channels and up to 100 watts per channel are designed to be ultra efficient, ultra cool, and ultra reliable, putting more performance in less space.

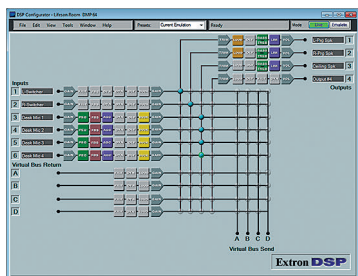

DSP Configurator Software

Digital Signal Processing

Extron offers audio DSP products for auditoriums, conferencing, and a variety of other sound reinforcement applications. Models are available with Acoustic Echo Cancellation, VoIP, USB Audio, and Dante. All feature Extron's exclusive ProDSP, for powerful audio processing and studio grade sonic quality. Processing algorithms including level, adaptive gain, automixing, dynamics, filters, delay, ducking, loudness, and feedback suppression, offer powerful audio solutions.



GlobalViewer Enterprise Software

AV Resource Management

The Extron GlobalViewer® family of software products allows support teams to remotely control and manage AV resources over the network, dramatically increasing their efficiency and effectiveness.

GlobalViewer Enterprise

Extron GlobalViewer Enterprise AV resource management software allows administrators and support personnel to get the most from their classroom AV systems. It provides single-school up to district-wide access to AV components over the network for remote support, energy management, and planning.

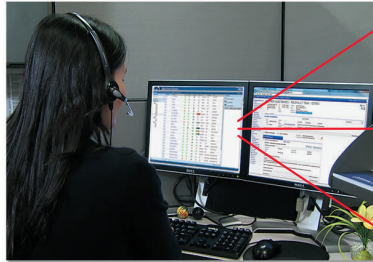

GlobalViewer Enterprise

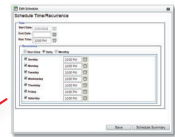

Scheduling



Reporting



Remote Management

Remote Monitoring and Support – Real-time monitoring of all classroom AV resources on the network ensures they are up and running, and being used to their potential. For support issues, technicians can remotely access the AV equipment in a particular room to assist users with system operation. Disconnect and Event Alert email messages alert the proper officials of a potential theft or other AV equipment problem in the classroom.

Energy Efficiency and Cost Savings – Automatically powering down AV components and scheduling system availability lowers operating costs and extends the life of equipment. Preventing projectors from being left on overnight or over the weekend allows lamps to last longer, and saves on energy bills.

Planning – Comprehensive reporting features provide important information for proactive maintenance and asset analysis. Lamp hour reports track usage and assist in lamp replacement scheduling. Usage reports for AV components serve as a valuable reference for resource allocation, budgeting, and professional development.

iGVE

Extron also offers a mobile AV resource management App, iGVE. This powerful, convenient App is used in conjunction with Extron GlobalViewer Enterprise, and allows users to effectively manage and control large-scale AV installations from Apple iPad, iPhone and iPod touch devices.



Technical Support

Extron is best known for our industry leading Technical Support. With offices around the globe, we are able to provide accurate and timely advice for all your system operation, configuration, and technical questions. The Extron S3 logo is a symbol in which Extron employees take personal pride. Extron's team recognizes that a relationship with our customers is what counts and we are prepared to provide you with the best Service, Support, and Solutions the industry has to offer.

Design Assistance

We understand that it can be difficult to know which AV products or system designs will address your unique classroom environments and methods of instruction. Extron has over 35 years of experience developing products and solutions for the education market, and we want to share our experience with you. Simply contact our S3 support line at with your project details and we will create a customized solution to suit your needs.

Training & Certification

Extron is the world's leading provider of training to the professional AV industry, delivering instruction to over 12,000 professionals every year. We offer a wide variety of training and certification programs to help customers keep pace with new technologies and product developments, including:

Sample Online Programs:

AV Associate Certification - Designed to give you an up-to-date and comprehensive understanding of audio, video, and control fundamentals along with a greater awareness of systems technologies and improved troubleshooting skills.

AV Principles - Designed to provide a general understanding of AV technology, along with a greater awareness of Extron solutions and system applications.

Sample Instructor-led Programs:

The School of Emerging Technologies 4K - Two-day school that concentrates on preparing AV infrastructure for 4K. Topics include 4K signal processing, wireless for AV, Extron DTP/XTP twisted pair systems, AV streaming, sound reinforcement and audio reproduction, and AV control strategies.

Extron Control Specialist and Control Professional Certification

The Extron Control Certification programs are designed to prepare individuals to successfully deploy and maintain customized AV control systems that are built using Extron Pro Series control products and Extron Global Configurator Plus and Global Configurator Professional software. Students can expect a challenging series of education modules focused on control system design concepts, advanced configuration techniques, and troubleshooting.

Extended Warranty Program

The Extron Extended Warranty program provides a unique opportunity for education customers to receive a two-year extension on all standard warranties, from three years to five years for parts and labor, at no additional cost. To qualify, installation must be completed by an authorized reseller and system controllers connected to the network. Contact your Extron Education Support Team representative to register your project, and receive the benefits of the extended warranty program.

Extron Grant Program

The goal of the Extron Grant Program is to provide increased visibility and expanded access to AV solutions, allowing key decision makers to evaluate technologies and define AV system standards. Our GlobalViewer Enterprise Grant demonstrates the benefits of managing, monitoring, and controlling AV devices over the network. To apply, complete the application at www.extron.com/gvegrant. Once your information has been submitted, an Extron Grant Administrator will be in touch to discuss your project.

Online Resources

Extron education websites are designed exclusively for anyone at education institutions involved in selecting, purchasing, or supporting AV presentation equipment. Sign up for a login at www.extron.com/highered and gain access to:

[Design guides](#) | [White Papers](#) | [Design Assistance](#) | [Grant Application](#)
[Education Pricing](#) | [Case Studies](#) | [System Builders](#) | [Software Download](#)

In addition, Extron has a number of online tools available at www.extron.com/tools/ to help designers create systems and make the right product selections, including;

System Builders – Easy to use utilities for creating complete systems that meet your requirements and generating a bill of material or custom part number for easy ordering and project tracking.

[Classroom AV System Builder](#) | [TeamWork System Builder](#)
[XTP System Builder](#) | [Cable Cubby Builder](#) | [Matrix Builder](#)

Calculators – helpful reference tools for a variety of audio, video, data, and power applications.

[Ceiling and Pendant Speaker Calculators](#) | [Amplifier Power Required](#)
[4K Data Rate Calculator](#) | [XTP Energy Consumption Calculator](#)

Engineering & System Design Resources

[AutoCAD Block Diagrams](#) | [Revit BIM files](#) | [A&E Specifications](#)

Extron Satisfaction Guarantee



As a leading manufacturer in the AV industry, we are committed to engineering and manufacturing our products to the highest standards of quality, performance, and value. From our advanced product design, manufacturing and quality control procedures to our friendly and knowledgeable support teams, our commitment to satisfy you is paramount. In every interaction with Extron, you can be confident you will receive our S3 commitment to Service, Support, and Solutions. For 36 years, our objective has been to ensure that every customer is completely satisfied with every purchase.

To underscore this commitment, we offer our Satisfaction Guarantee. This means we will work diligently to resolve any issue you have with your purchase until you are completely satisfied. Our dedicated Education Support Team will contact you after installation to ensure your satisfaction and that systems are being used to their full potential. We are prepared to do whatever it takes to make certain that the entire process of doing business with us is a positive and professionally rewarding experience for you.

I'm so confident in our ability to deliver on this pledge that I back it personally. If you are not satisfied with any part of your transaction with Extron, I want to know. Please contact me at president@extron.com. I will personally address any unresolved customer issue. We greatly appreciate your business. It is our intent to keep you as a customer for life.



Andrew C. Edwards
President, Extron Electronics

Extron Support

Extron is best known for our industry leading Technical Support. With offices around the globe, we are able to provide accurate and timely advice for all your system operation, configuration, and technical questions.



Extron Europe
+800.3987.6673, +31.33.453.4040
Fax: +31.33.453.4050

Extron Middle East
+971.4.299.1800,
Fax: +971.4.299.1880

Extron India
+91.80.6819.8000

Extron Electronics Asia Pte Ltd
+65.6383.4400

Extron Australia
+61.8.8113.6800
Tech Support: 1800.997.637

Extron China
4000.EXTRON / 4000.398766
Fax: +86.21.3760.1566

Extron Japan
+81.3.3511.7655
Fax: +81.3.3511.7656.