

## Series ES05



AVENTICS™ Series ES05



# Valve system, Series ES05

- Configurable valve systems



Certificates	UR (Underwriters Laboratories)
Working pressure min./max.	-11 ... 116 psi
Control pressure min./max.	44 ... 116 psi
Ambient temperature min./max.	41 ... 122 °F
Medium temperature min./max.	41 ... 122 °F
Medium	Compressed air
Max. particle size	40 µm
Oil content of compressed air	0 ... 5 mg/m³
Nominal flow Qn	0.62 Cv
Operational voltage electronics	24 V DC
Number of valve positions max.	12
Number of solenoid coils max.	24
Protection class with connection	IP65 IP50
DC operating voltage	24 V
Voltage tolerance DC	-15% / +10%
Duty cycle	100 %

An example configuration is illustrated.  
The delivered product may thus deviate from the illustration.

## Overview of variants

	Version	You have the following options:
	Multipole	D-Sub plug, 25-pin, on the side
	Single plug-in wiring	Electrical connection Valve plug connector form C industry
	Single plug-in wiring	Electrical connection M8x1 (3-pin)
	Fieldbus connection with I/O functionality (AES)	PROFINET IO EtherCAT DeviceNet POWERLINK PROFIBUS DP CANopen EtherNET/IP POWERLINK
	IO-Link	type B

## Technical information

The min. control pressure must be adhered to, since otherwise faulty switching and valve failure may result!

The pressure dew point must be at least 27 °F under ambient and medium temperature and may not exceed 5.4 °F .

The oil content of compressed air must remain constant during the life cycle.

Use only the approved oils from AVENTICS. Further information can be found in the "Technical information" document (available in the MediaCentre).

See the following pages on the series for technical data on individual components.

Do not permanently control more than 2 neighboring valves (see operating instructions)

Only use fittings with cylindrical threads (BSPP).

## Technical information

Material	
End plate	Polyamide fiber-glass reinforced
Base plate	Polyamide fiber-glass reinforced

## Dimensions

### Dimensions, D-Sub plug, 25-pin, on the side

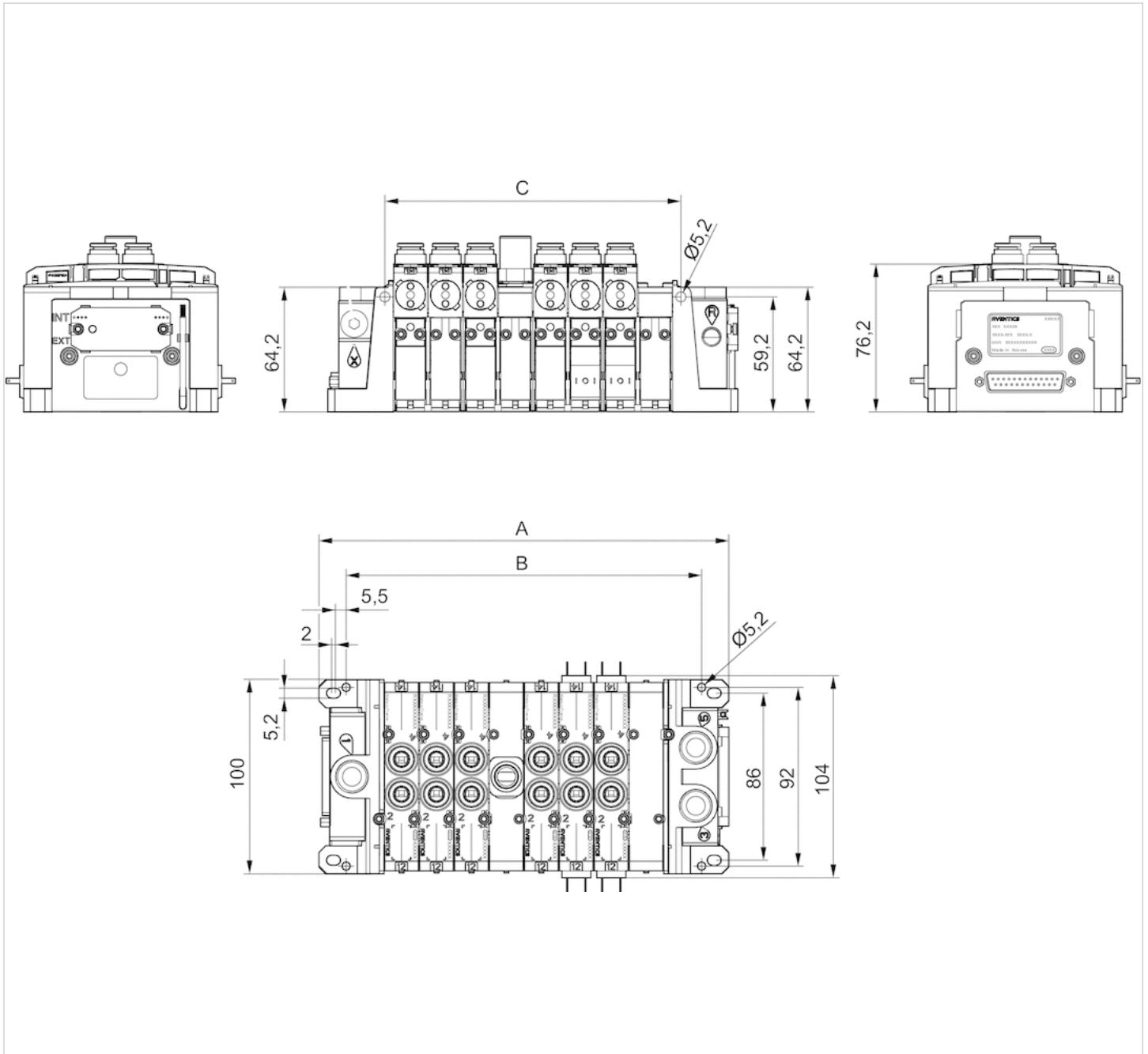

A = number of subbases x 36 + 67 mm

B = number of subbases x 36 + 39 mm

C = number of subbases x 36 + 8,4 mm

1 = compressed air connection, G3/8"

2, 4 = working connection,  $\varnothing 8$  or D3/8"

3, 5 = exhaust, G3/8"

R = pilot exhaust air, G1/8"

X = connection for external pilot, G1/8"

An example configuration is shown. You can calculate the dimensions for your configuration using the formula or read them directly in the configurator.

Dimensions, Valve plug connector form C industry

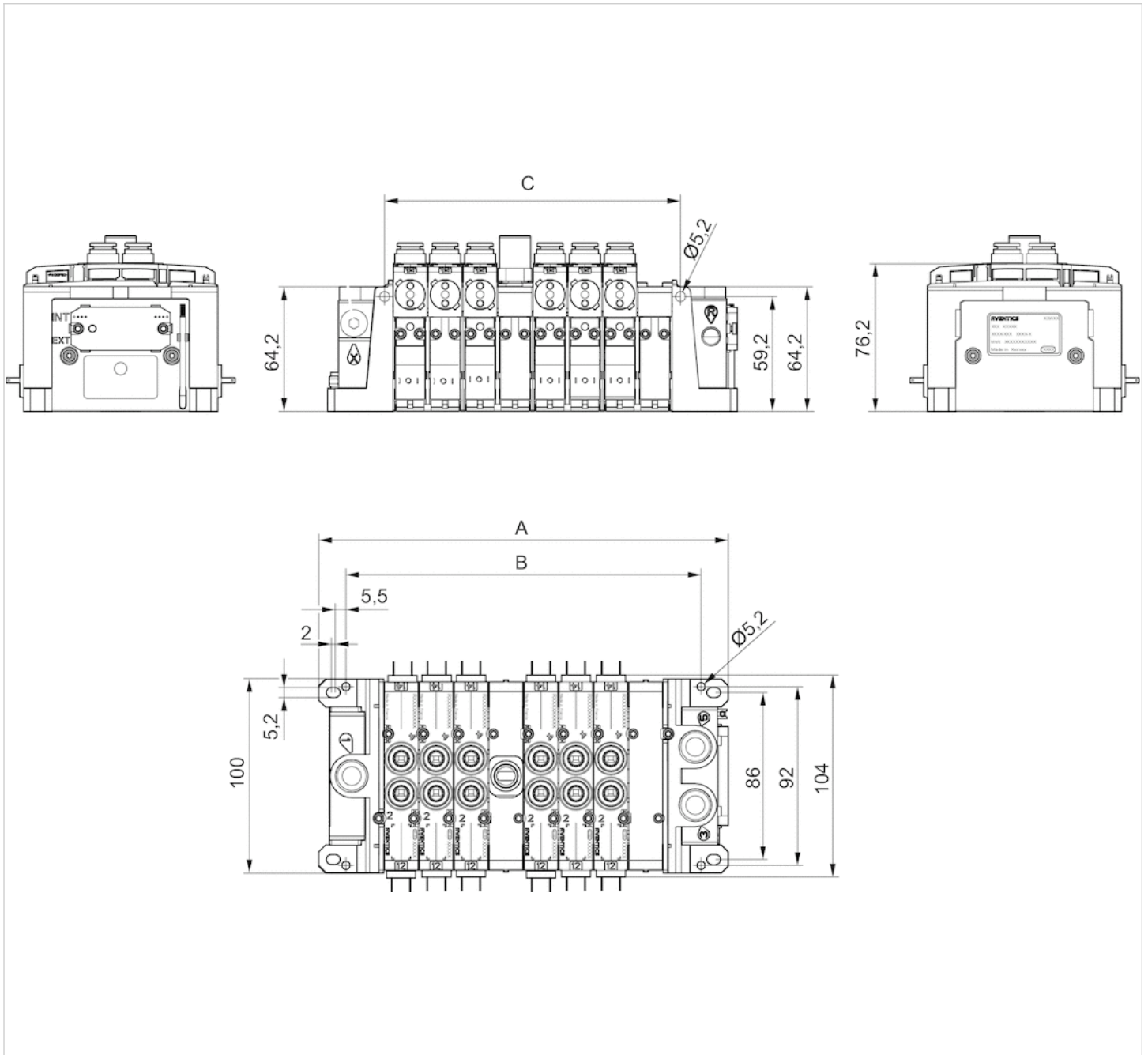

A = number of subbases x 36 + 67 mm

B = number of subbases x 36 + 39 mm

C = number of subbases x 36 + 8,4 mm

1 = compressed air connection, G3/8"

2, 4 = working connection,  $\varnothing 8$  or D3/8"

3, 5 = exhaust, G3/8"

R = pilot exhaust air, G1/8"

X = connection for external pilot, G1/8"

An example configuration is illustrated. The delivered product may thus deviate from the illustration.

Dimensions, Electr. connection: M8, 3-pin

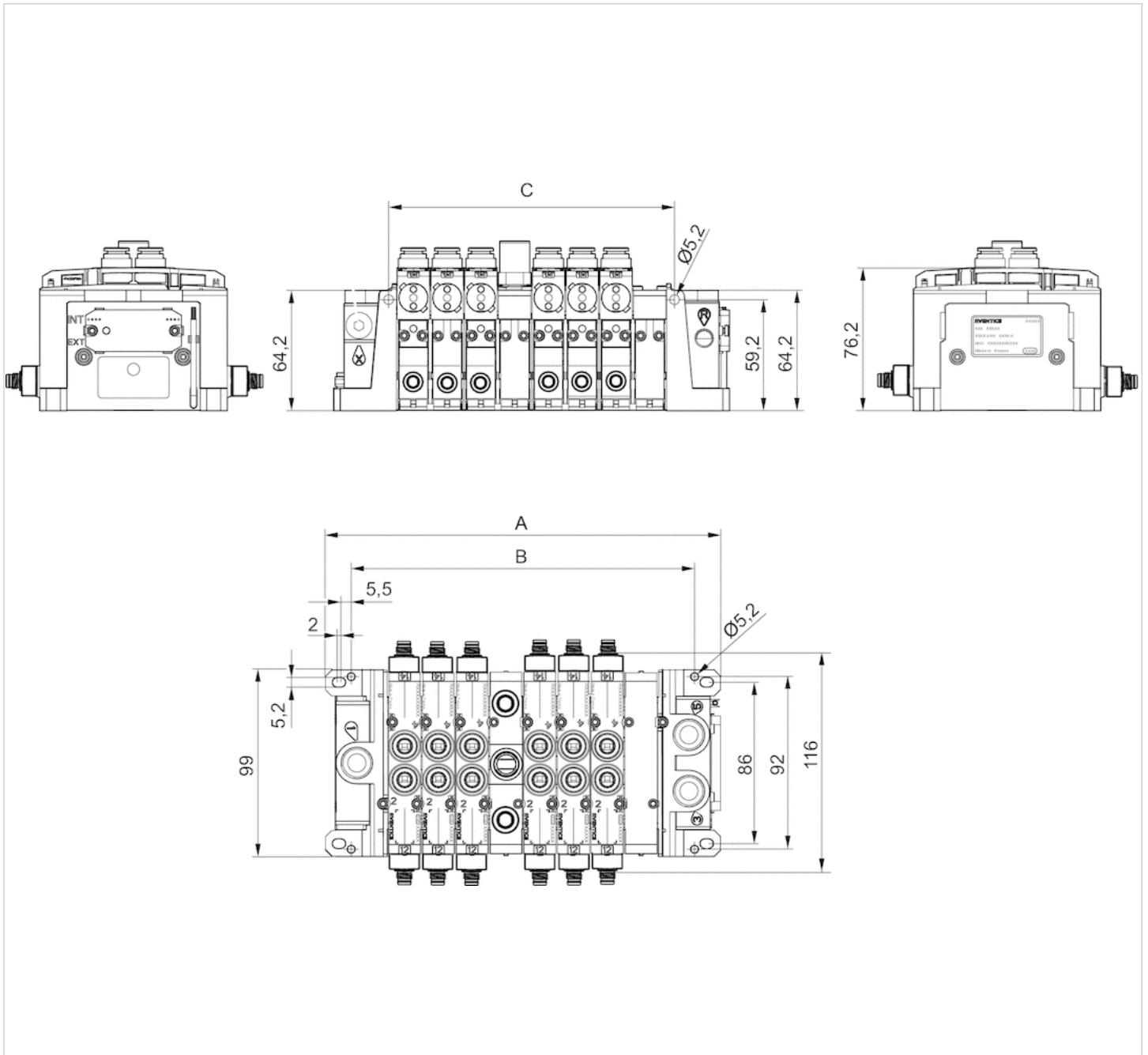

A = number of subbases x 36 + 67 mm

B = number of subbases x 36 + 39 mm

C = number of subbases x 36 + 8,4 mm

1 = compressed air connection, G3/8"

2, 4 = working connection,  $\varnothing 8$  or D3/8"

3, 5 = exhaust, G3/8"

R = pilot exhaust air, G1/8"

X = connection for external pilot, G1/8"

An example configuration is illustrated. The delivered product may thus deviate from the illustration.

Dimensions, Fieldbus connection with I/O functionality (AES)

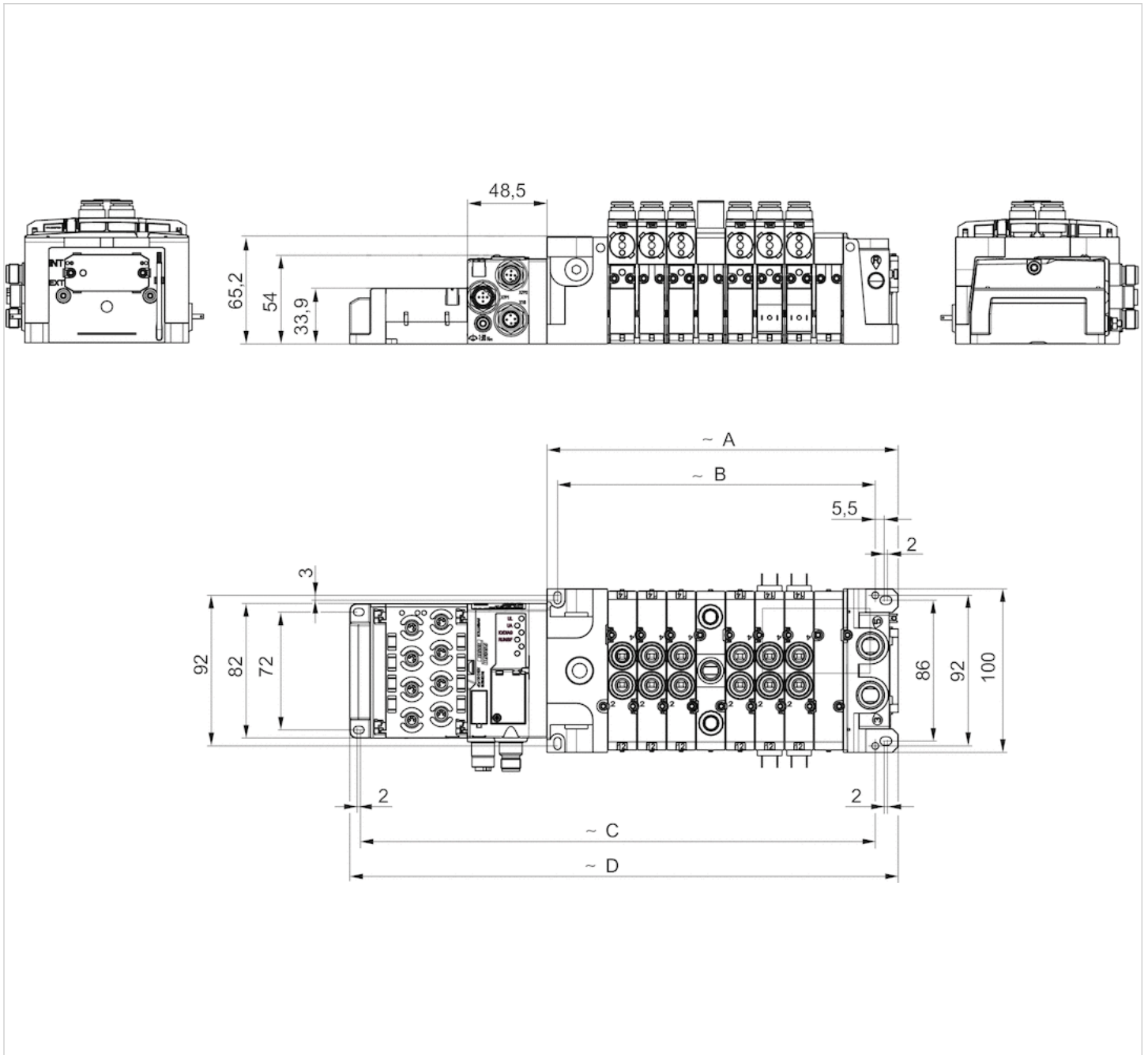

- A = number of subbases x 36 + 70,5 mm
- B = number of subbases x 36 + 50 mm
- C = number of subbases x 36 + number of I/O modules x 50 + 120.5 mm
- D = number of subbases x 36 + number of I/O modules x 50 + 141 mm
- 1 = compressed air connection, G3/8"
- 2, 4 = working connection, Ø8 or D3/8"
- 3, 5 = exhaust, G3/8"
- R = pilot exhaust air, G1/8"
- X = connection for external pilot, G1/8"

An example configuration is shown. You can calculate the dimensions for your configuration using the formula or read them directly in the configurator.

Dimensions, IO-Link

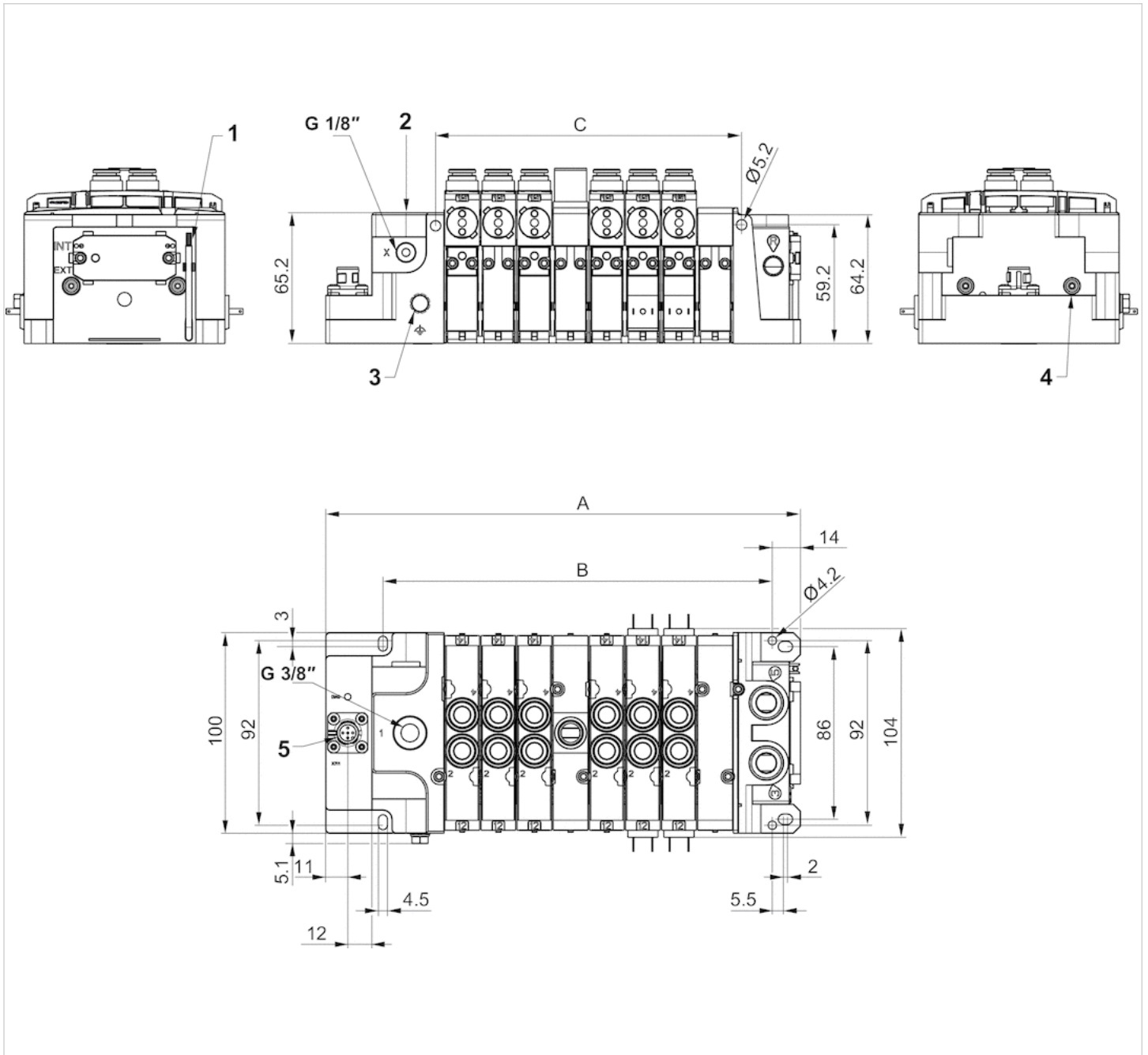

- 1) Hexalobular socket (TORX) ISO 10664-10
- 2) End plate left, IO-Link
- 3) Ground
- 4) Hexalobular socket (TORX) ISO 10664-10
- 5) M12 plug





## 2x3/2-directional valve, Series ES05

- 2x3/2
- $Q_n = 0.376\text{-}0.508\text{ Cv}$
- NC/NC NO/NO
- Compressed air connection output :  $\varnothing 8$
- Electrical connection : form C, industry
- Manual override : without detent
- single solenoid



Activation	Electrically
Certificates	UR (Underwriters Laboratories)
Working pressure min./max.	44 ... 116 psi
Ambient temperature min./max.	41 ... 122 °F
Medium temperature min./max.	41 ... 122 °F
Medium	Compressed air
Max. particle size	40 $\mu\text{m}$
Oil content of compressed air	0 ... 5 $\text{mg}/\text{m}^3$
Nominal flow $Q_n$	See table below
Protection class with connection	IP65
Duty cycle	100 %

### Technical data

Part No.			Compressed air connection	
			Input	Output
R422103177		NC/NC	$\varnothing 8$	$\varnothing 8$
R422103178		NO/NO	$\varnothing 8$	$\varnothing 8$

Part No.	Compressed air connection		Operational voltage	Voltage tolerance
	Exhaust		DC	DC
R422103177	$\varnothing 8$		24 V	-15% / +10%
R422103178	$\varnothing 8$		24 V	-15% / +10%

Part No.	Power consumption		Nominal flow $Q_n$	Switch-on time	Switch-off time
	DC				
R422103177	2 W		0.508 Cv	20	20
R422103178	2 W		0.376 Cv	20	20

Nominal flow  $Q_n$  at 87 psi and  $\Delta p = 14.5\text{ psi}$

### Technical information

The min. control pressure must be adhered to, since otherwise faulty switching and valve failure may result!  
 The pressure dew point must be at least 27 °F under ambient and medium temperature and may not exceed 5.4 °F .  
 The oil content of compressed air must remain constant during the life cycle.  
 Use only the approved oils from AVENTICS. Further information can be found in the "Technical information" document (available in the MediaCentre).  
 The pilot valve is UL (Underwriters Laboratories) certified.  
 Exhaust air throttling may only be used in operating lines

## Technical information

Material

Housing

Polyamide fiber-glass reinforced

## Dimensions

Dimensions

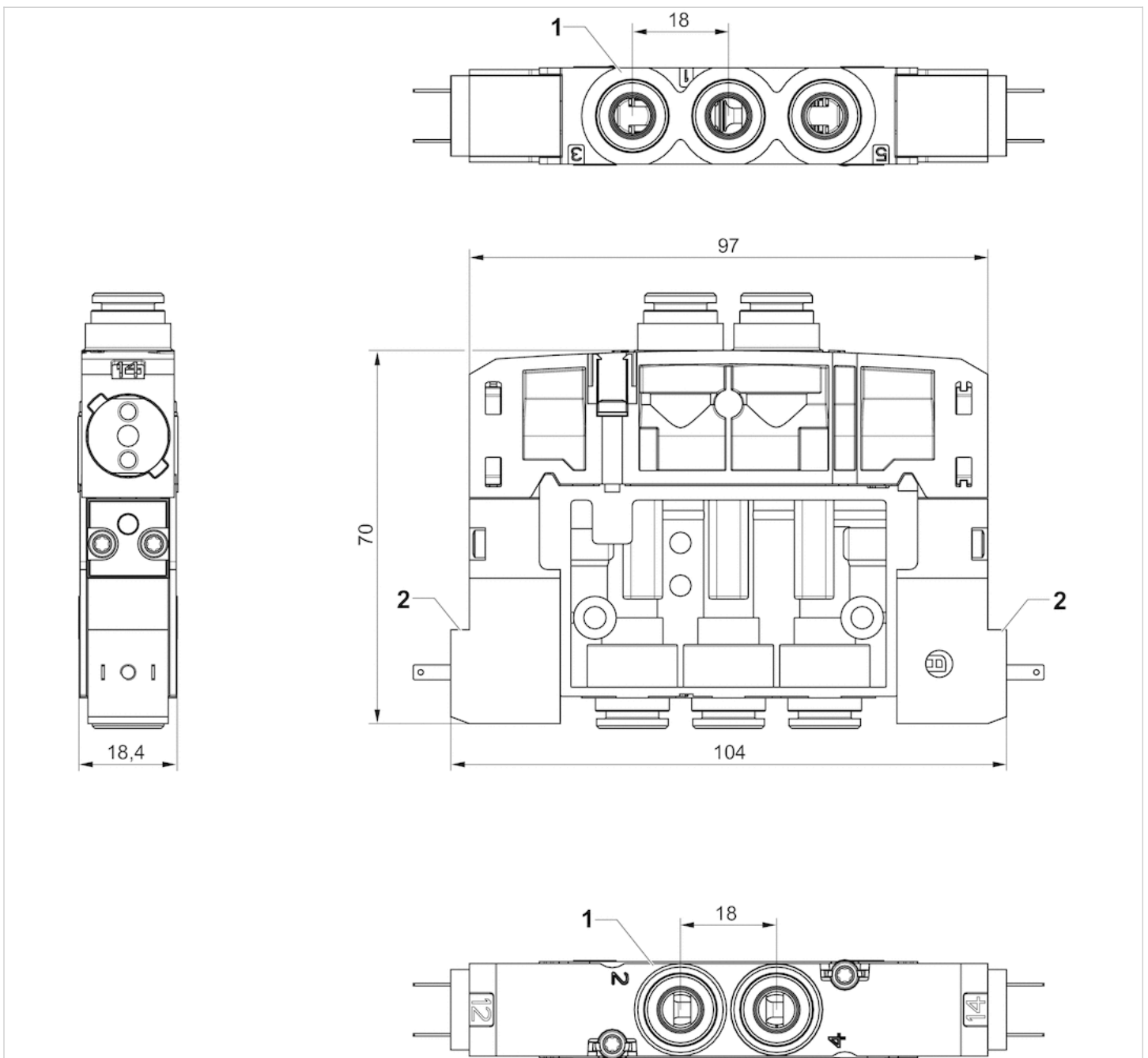

1) Connections [1 ,3 ,5, 2, 4] Ø 8

2) 2 pilot valves with external electrical connection



# 2x3/2-directional valve, Series ES05

- 2x3/2
- $Q_n = 0.376\text{--}0.508\text{ Cv}$
- NC/NC NO/NO
- Compressed air connection output :  $\varnothing 8$
- Electrical connection : M8x1, 3-pin
- Manual override : without detent
- single solenoid



Activation	Electrically
Working pressure min./max.	44 ... 116 psi
Ambient temperature min./max.	41 ... 122 °F
Medium temperature min./max.	41 ... 122 °F
Medium	Compressed air
Max. particle size	40 $\mu\text{m}$
Oil content of compressed air	0 ... 5 $\text{mg}/\text{m}^3$
Nominal flow $Q_n$	See table below
Protection class with connection	IP65
Duty cycle	100 %

## Technical data

Part No.			Compressed air connection	
			Input	Output
R422103857		NC/NC	$\varnothing 8$	$\varnothing 8$
R422103858		NO/NO	$\varnothing 8$	$\varnothing 8$

Part No.	Compressed air connection		Operational voltage	Voltage tolerance
	Exhaust		DC	DC
R422103857	$\varnothing 8$		24 V	-15% / +10%
R422103858	$\varnothing 8$		24 V	-15% / +10%

Part No.	Power consumption		Nominal flow $Q_n$	Switch-on time	Switch-off time
	DC				
R422103857	2 W		0.508 Cv	20	20
R422103858	2 W		0.376 Cv	20	20

Nominal flow  $Q_n$  at 87 psi and  $\Delta p = 14.5\text{ psi}$

## Technical information

The min. control pressure must be adhered to, since otherwise faulty switching and valve failure may result!  
 The pressure dew point must be at least 27 °F under ambient and medium temperature and may not exceed 5.4 °F .  
 The oil content of compressed air must remain constant during the life cycle.  
 Use only the approved oils from AVENTICS. Further information can be found in the "Technical information" document (available in the MediaCentre).

Exhaust air throttling may only be used in operating lines

## Technical information

### Material

Housing

Polyamide fiber-glass reinforced

## Dimensions

### Dimensions

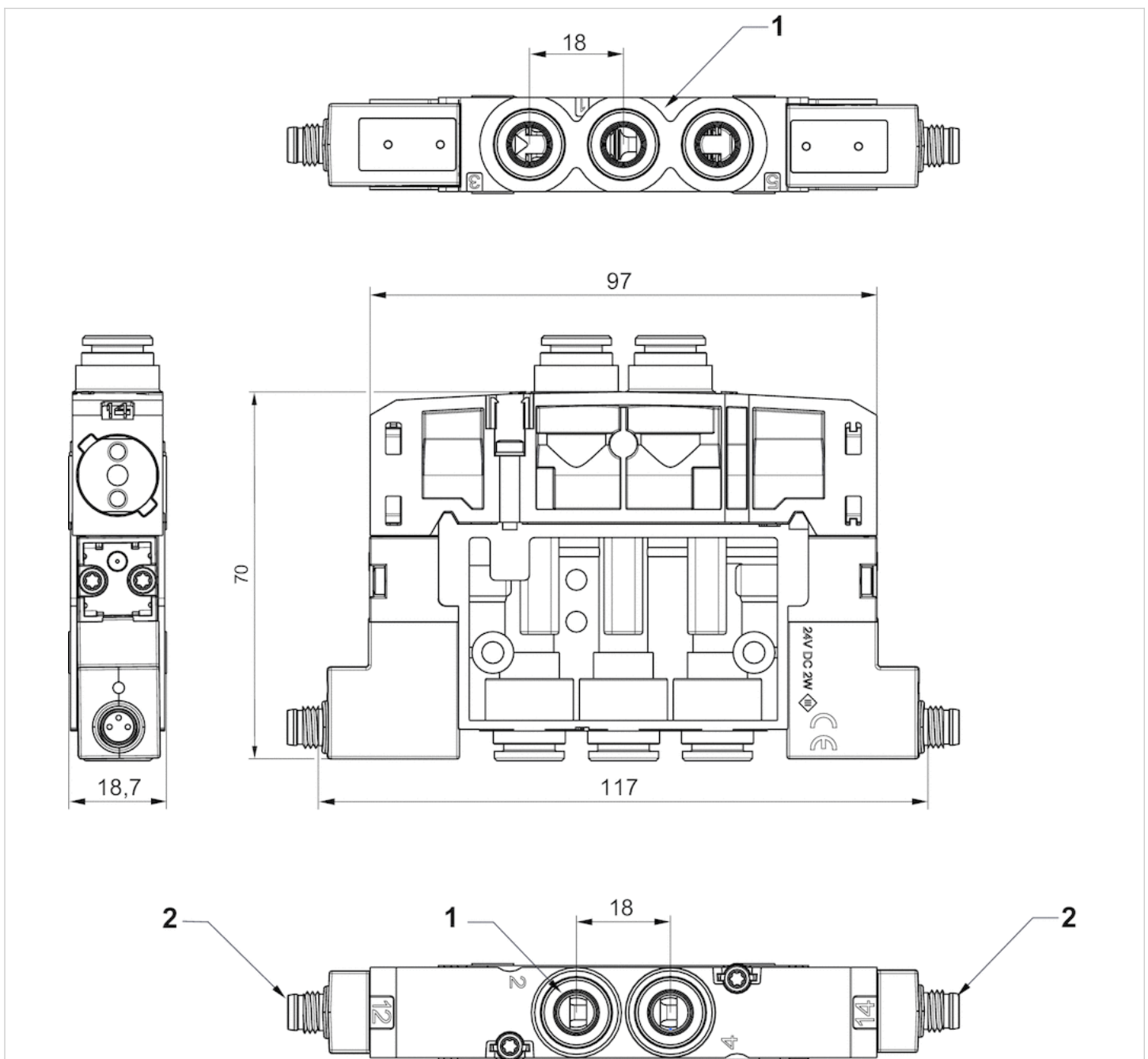

1) Connections [ 1 , 3 , 5 , 2 , 4 ]  $\varnothing$  8

2) 1 pilot valve with electrical connection M8x1

## Pin assignments

### PIN assignment for valve plug connectors

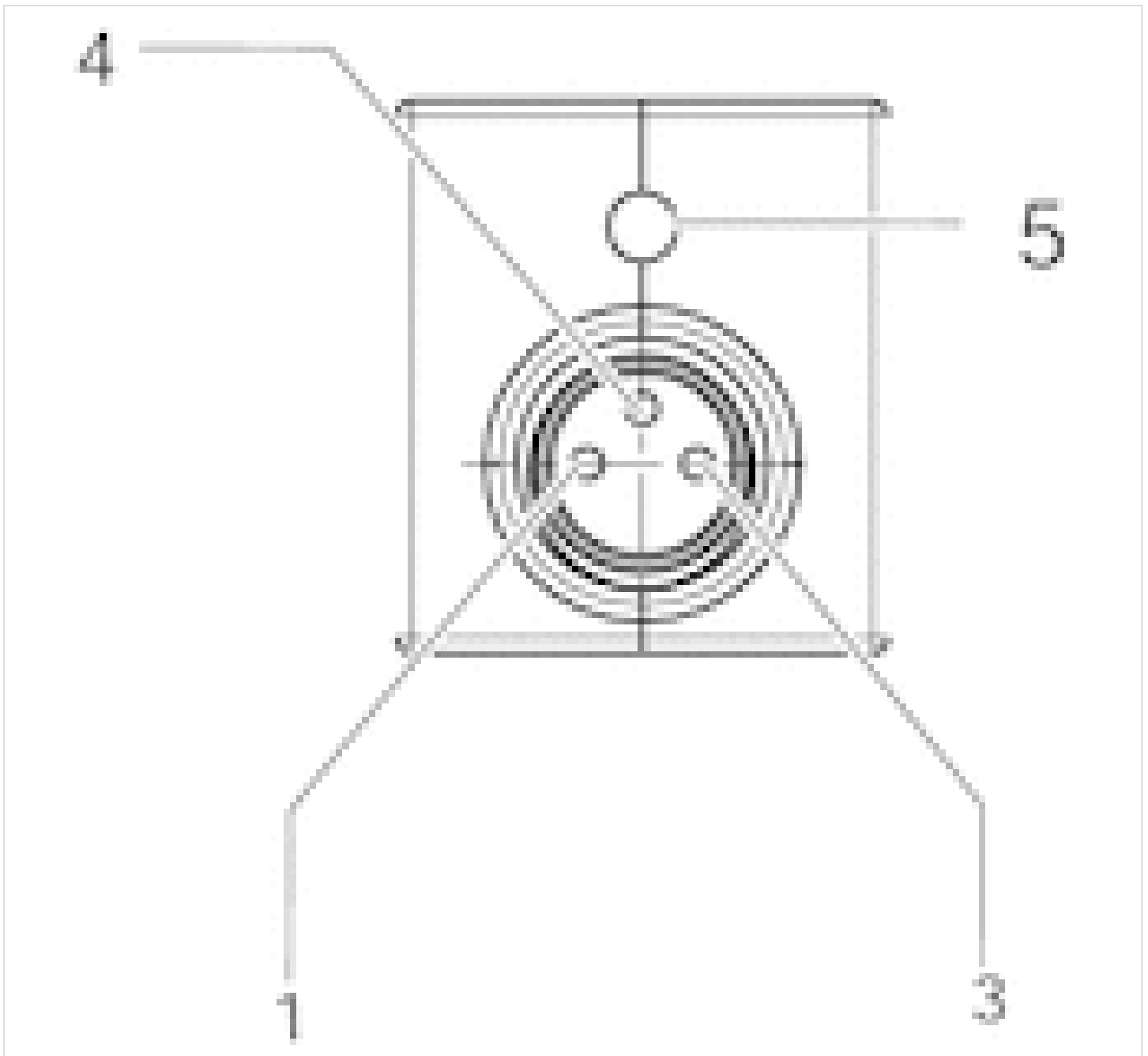

Pin assignment:

- 1) Pin not assigned
- 3) 0 V
- 4) 24 V
- 5) LED

Note: Bi-polar protective circuit to prevent overvoltage



# 5/2-directional valve, Series ES05

- 5/2
- $Q_n = 0.62 \text{ Cv}$
- Compressed air connection output :  $\varnothing 8$
- Electrical connection : form C, industry
- Manual override : without detent
- single solenoid double solenoid



Activation	Electrically
Certificates	UR (Underwriters Laboratories)
Working pressure min./max.	44 ... 116 psi
Ambient temperature min./max.	41 ... 122 °F
Medium temperature min./max.	41 ... 122 °F
Medium	Compressed air
Max. particle size	40 $\mu\text{m}$
Oil content of compressed air	0 ... 5 $\text{mg}/\text{m}^3$
Nominal flow $Q_n$	0.62 Cv
Protection class with connection	IP65
Duty cycle	100 %

## Technical data

Part No.		Compressed air connection	
		Input	Output
R422103175		$\varnothing 8$	$\varnothing 8$
R422103176		$\varnothing 8$	$\varnothing 8$

Part No.	Compressed air connection		Operational voltage	Voltage tolerance
	Exhaust			
R422103175	$\varnothing 8$		DC	DC
R422103176	$\varnothing 8$		24 V	-15% / +10%

Part No.	Power consumption		Switch-on time	Switch-off time	Fig.
	DC				
R422103175	2 W		20	35	Fig. 1
R422103176	2 W		20	20	Fig. 2

Nominal flow  $Q_n$  at 87 psi and  $\Delta p = 14.5 \text{ psi}$

## Technical information

The min. control pressure must be adhered to, since otherwise faulty switching and valve failure may result!  
 The pressure dew point must be at least 27 °F under ambient and medium temperature and may not exceed 5.4 °F .  
 The oil content of compressed air must remain constant during the life cycle.  
 Use only the approved oils from AVENTICS. Further information can be found in the "Technical information" document (available in the MediaCentre).  
 The pilot valve is UL (Underwriters Laboratories) certified.  
 Exhaust air throttling may only be used in operating lines

## Technical information

### Material

Housing	Polyamide fiber-glass reinforced
Seals	Acrylonitrile butadiene rubber

## Dimensions

Fig. 1, single solenoid

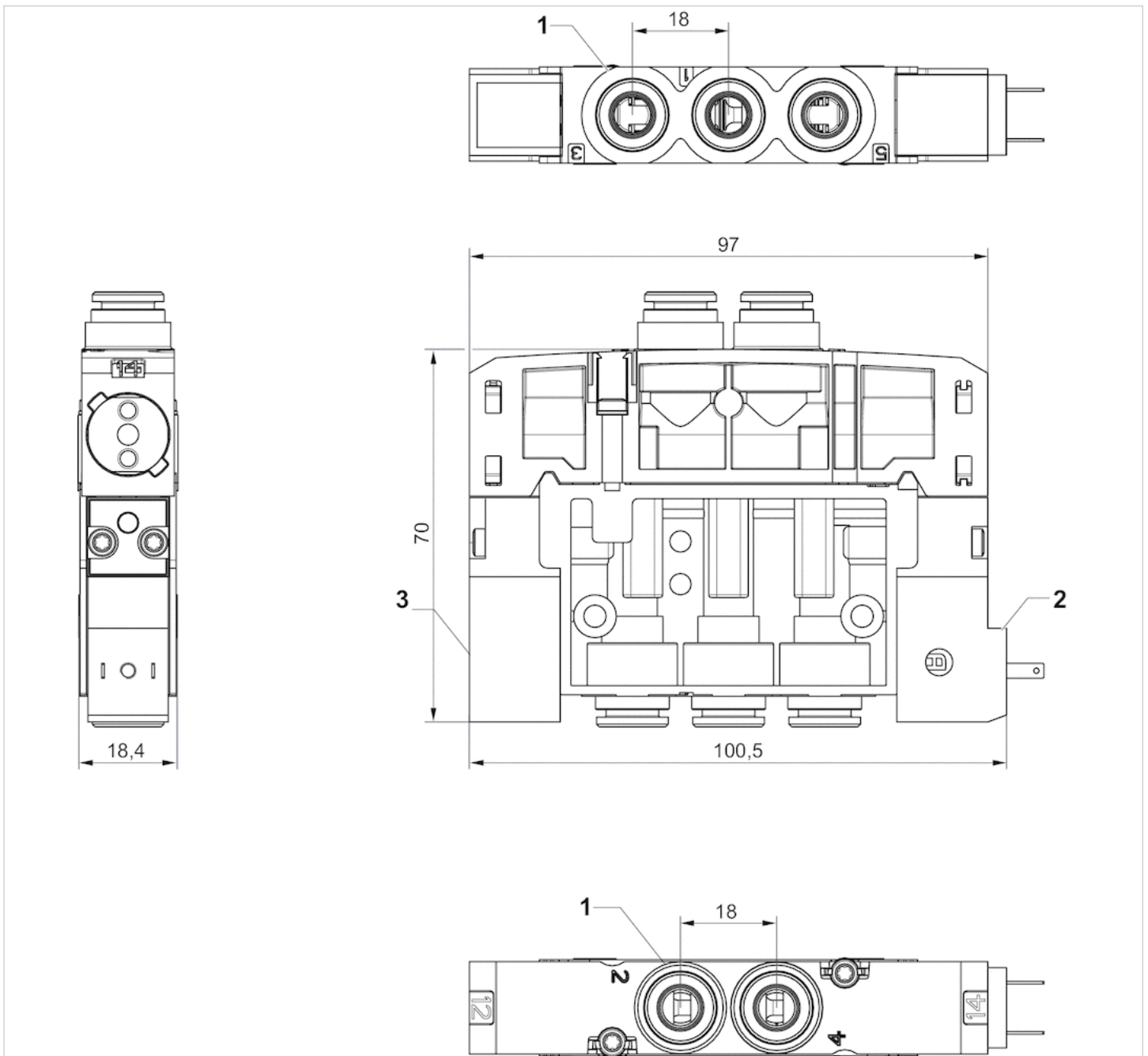

- 1) Connections [1 ,3 ,5, 2, 4] Ø 8
- 2) 1 pilot valve with electrical connection
- 3) Pilot blanking plate

Fig. 2, double solenoid

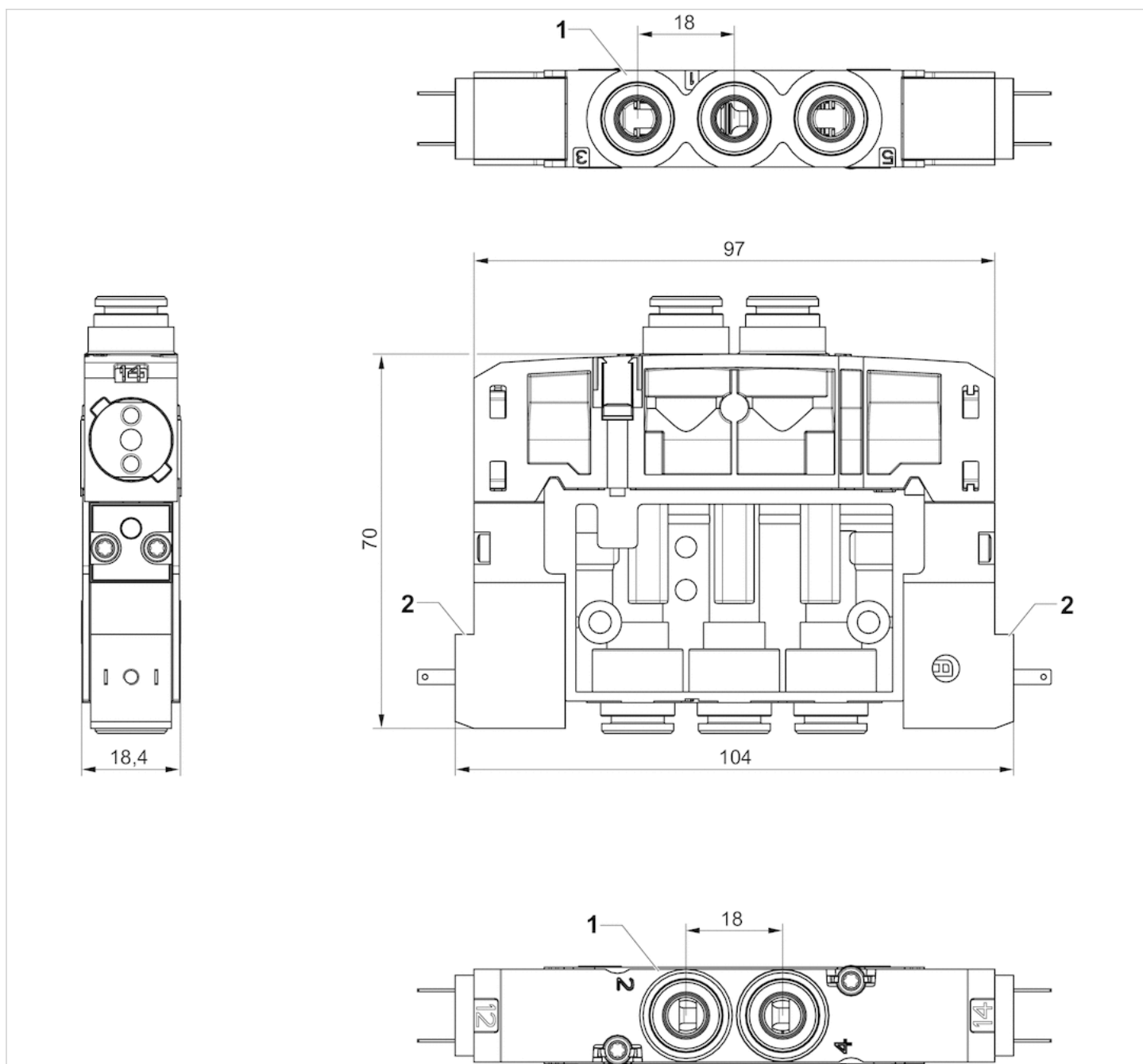

1) Connections [1 ,3 ,5, 2, 4] Ø 8

2) 2 pilot valves with external electrical connection





# 5/2-directional valve, Series ES05

- 5/2
- $Q_n = 0.62 \text{ Cv}$
- Compressed air connection output :  $\varnothing 8$
- Electrical connection : M8x1, 3-pin
- Manual override : without detent
- single solenoid double solenoid



Activation	Electrically
Working pressure min./max.	44 ... 116 psi
Ambient temperature min./max.	41 ... 122 °F
Medium temperature min./max.	41 ... 122 °F
Medium	Compressed air
Max. particle size	40 $\mu\text{m}$
Oil content of compressed air	0 ... 5 $\text{mg}/\text{m}^3$
Nominal flow $Q_n$	0.62 Cv
Protection class with connection	IP65
Duty cycle	100 %

## Technical data

Part No.		Compressed air connection	
		Input	Output
R422103855		$\varnothing 8$	$\varnothing 8$
R422103856		$\varnothing 8$	$\varnothing 8$

Part No.	Compressed air connection		Operational voltage	Voltage tolerance
	Exhaust			
R422103855	$\varnothing 8$		DC	DC
R422103856	$\varnothing 8$		24 V	-15% / +10%

Part No.	Power consumption		Switch-on time	Switch-off time	Fig.
	DC				
R422103855	2 W		20	35	Fig. 1
R422103856	2 W		20	20	Fig. 2

Nominal flow  $Q_n$  at 87 psi and  $\Delta p = 14.5 \text{ psi}$

## Technical information

The min. control pressure must be adhered to, since otherwise faulty switching and valve failure may result!  
 The pressure dew point must be at least 27 °F under ambient and medium temperature and may not exceed 5.4 °F .  
 The oil content of compressed air must remain constant during the life cycle.  
 Use only the approved oils from AVENTICS. Further information can be found in the "Technical information" document (available in the MediaCentre).

Exhaust air throttling may only be used in operating lines

## Technical information

Material	
Housing	Polyamide fiber-glass reinforced
Seals	Acrylonitrile butadiene rubber

## Dimensions

Fig. 1, single solenoid

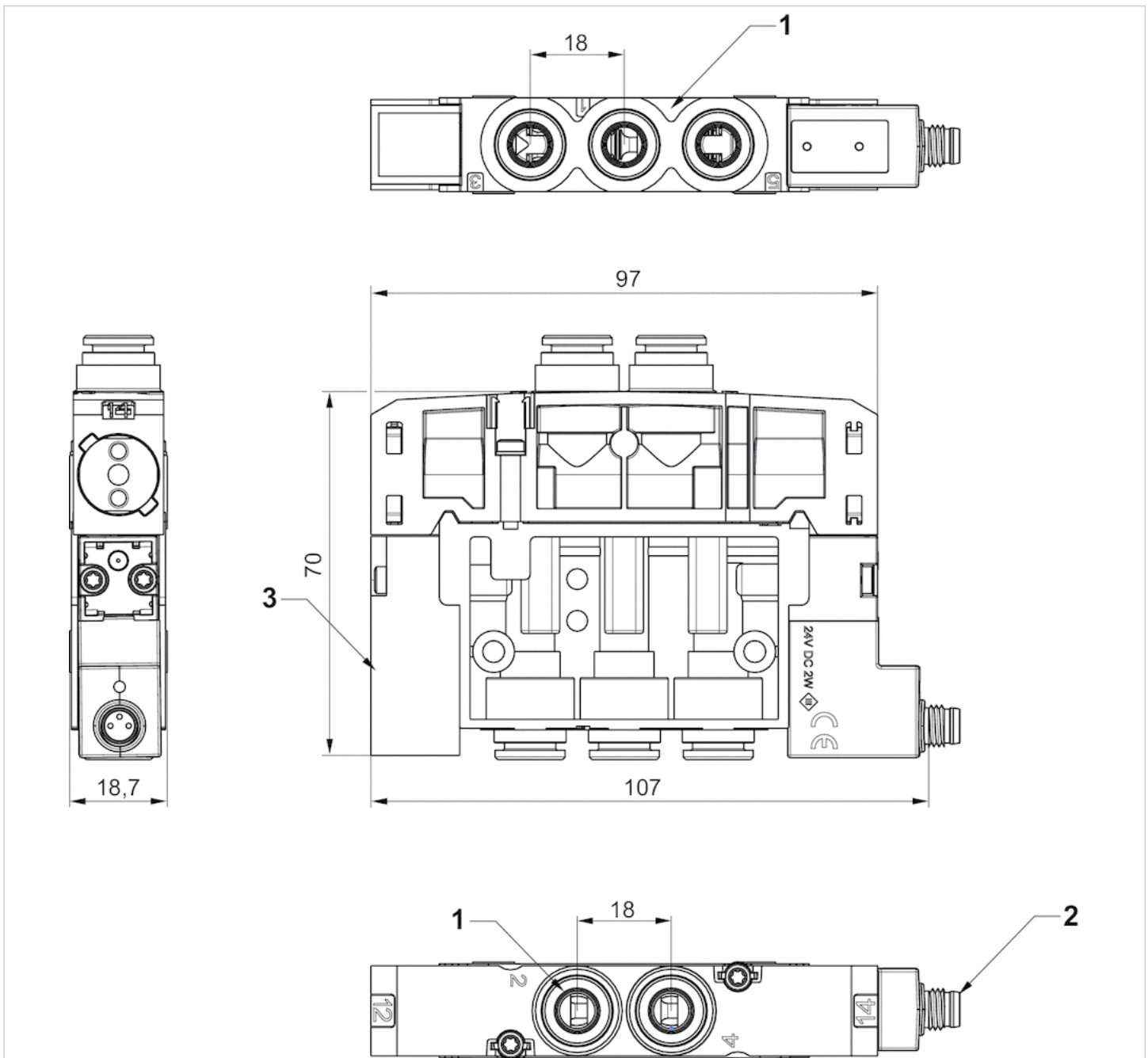

- 1) Connections [ 1 , 3 , 5, 2, 4] Ø 3/8
- 2) 2 pilot valves with external electrical connection M8x1
- 3) Pilot blanking plate

Fig. 2, double solenoid

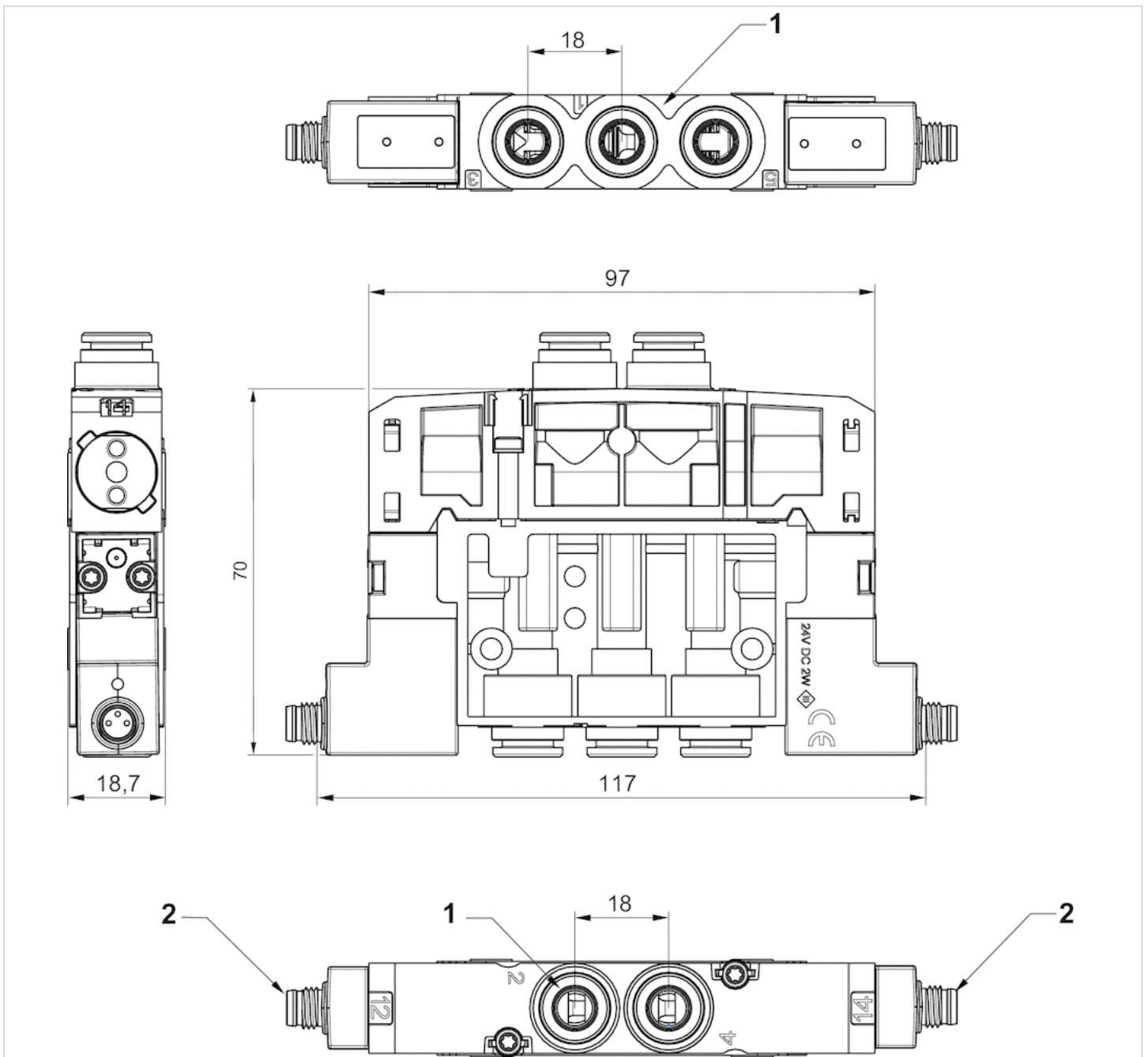

- 1) Connections [1 ,3 ,5, 2, 4] Ø 8
- 2) 2 pilot valves with external electrical connection M8x1

## Pin assignments

### PIN assignment for valve plug connectors

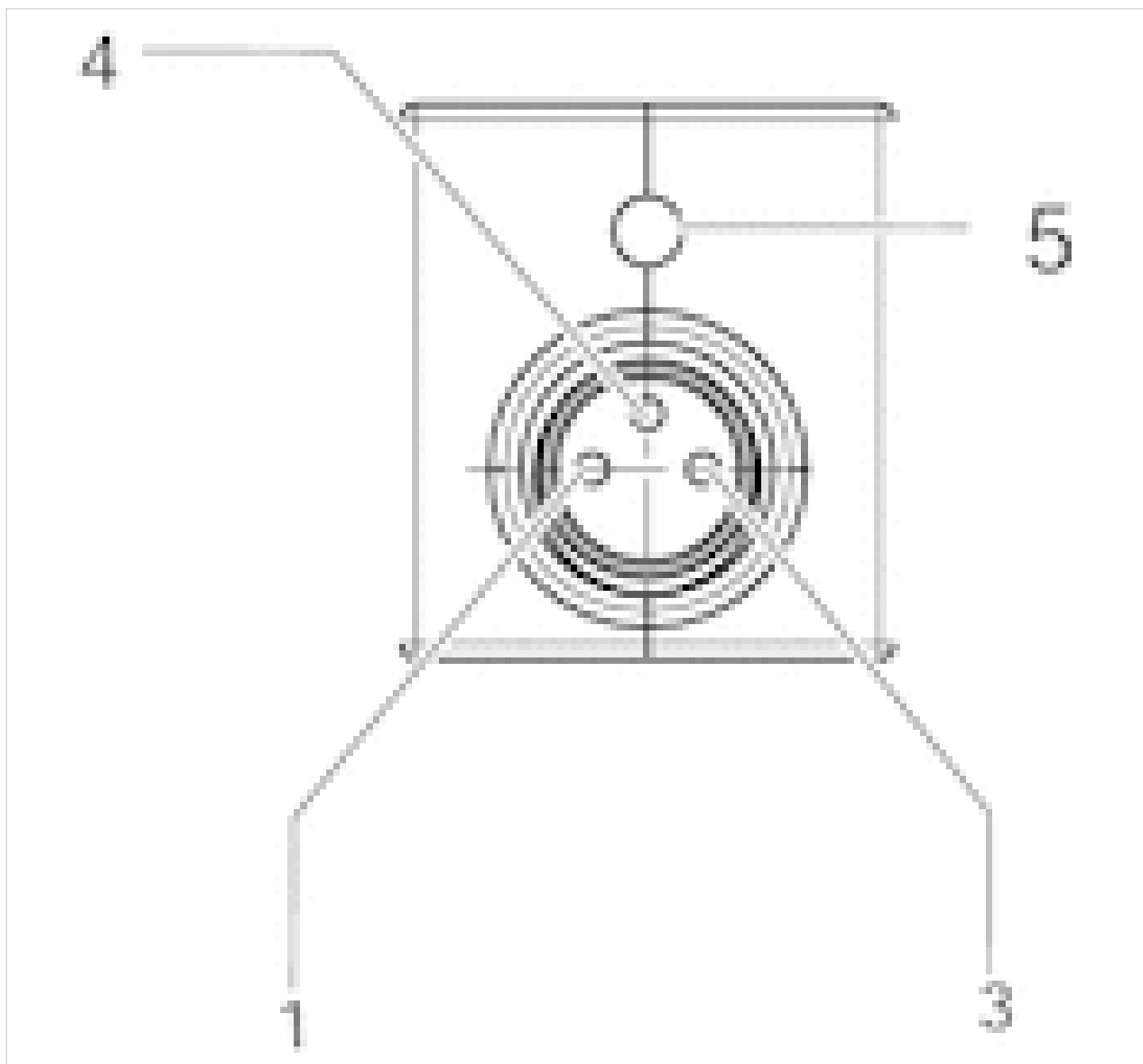

Pin assignment:

- 1) Pin not assigned
- 3) 0 V
- 4) 24 V
- 5) LED

Note: Bi-polar protective circuit to prevent overvoltage

# 5/3-directional valve, Series ES05

- 5/3
- Qn = 0.508 Cv
- closed center
- Compressed air connection output : Ø 8
- Electrical connection : form C, industry
- double solenoid



Activation	Electrically
Certificates	UR (Underwriters Laboratories)
Working pressure min./max.	44 ... 116 psi
Ambient temperature min./max.	41 ... 122 °F
Medium temperature min./max.	41 ... 122 °F
Medium	Compressed air
Max. particle size	40 µm
Oil content of compressed air	0 ... 5 mg/m³
Nominal flow Qn	0.508 Cv
Protection class with connection	IP65
LED status display	Yellow
Duty cycle	100 %

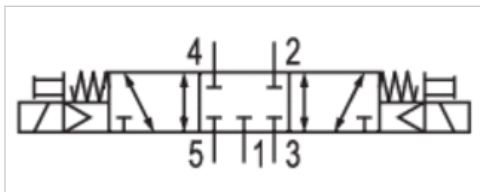

## Technical data

Part No.		Compressed air connection	
		Input	Output
R422103183	closed center	Ø 8	Ø 8

Part No.	Compressed air connection		Operational voltage	Voltage tolerance
	Exhaust			
R422103183	Ø 8		DC 24 V	DC -15% / +10%

Part No.	Power consumption		Switch-on time	Switch-off time
	DC			
R422103183	2 W		20	20

Nominal flow Qn at 87 psi and Δp = 14.5 psi, MO = Manual override

## Technical information

The min. control pressure must be adhered to, since otherwise faulty switching and valve failure may result!  
 The pressure dew point must be at least 27 °F under ambient and medium temperature and may not exceed 5.4 °F .  
 The oil content of compressed air must remain constant during the life cycle.  
 Use only the approved oils from AVENTICS. Further information can be found in the "Technical information" document (available in the MediaCentre).  
 The pilot valve is UL (Underwriters Laboratories) certified.

Exhaust air throttling may only be used in operating lines

## Technical information

Material	
Housing	Polyamide fiber-glass reinforced
Seals	Acrylonitrile butadiene rubber

## Dimensions

### double solenoid

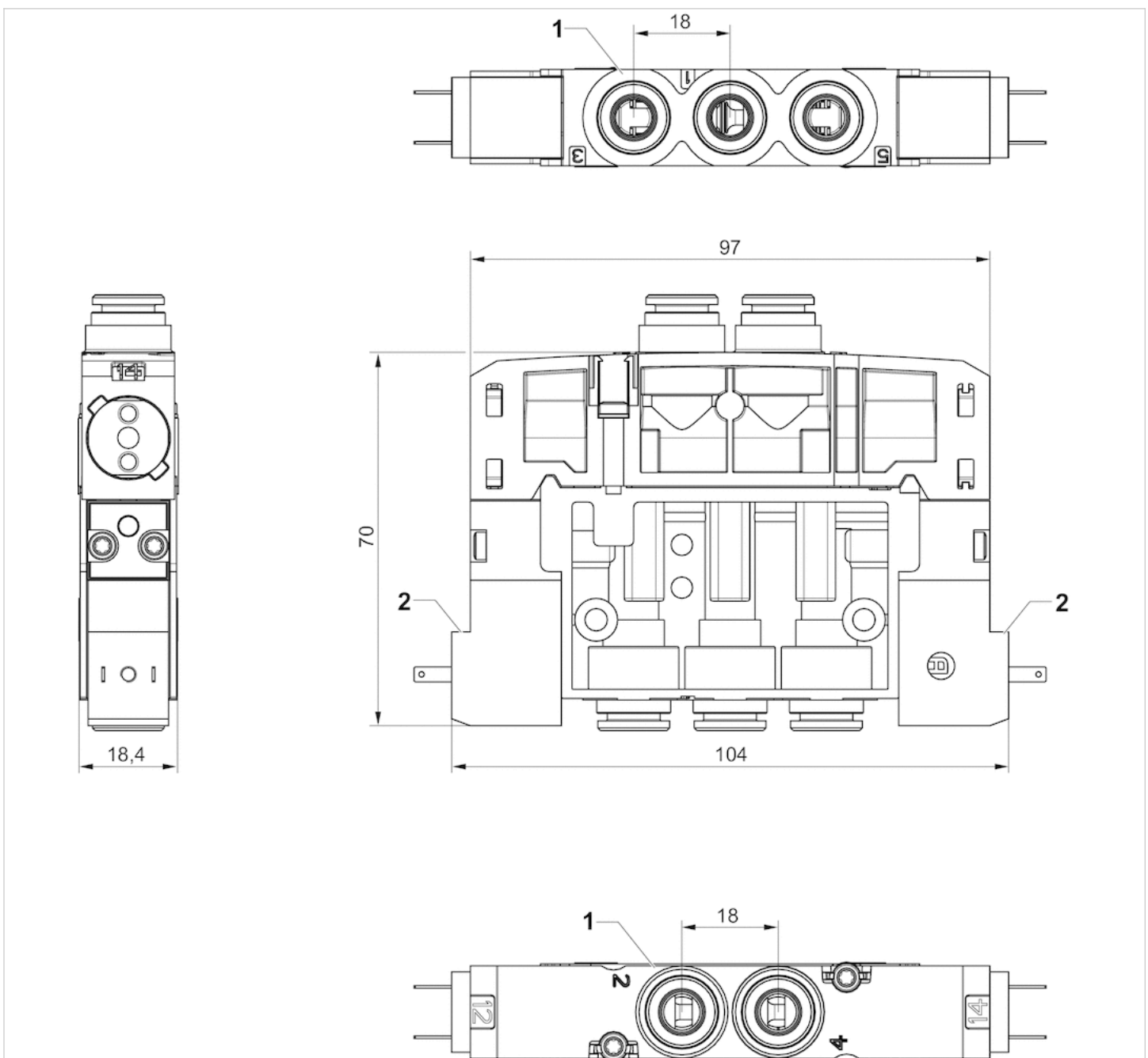

- 1) Connections [1, 3, 5, 2, 4] Ø 8
- 2) 2 pilot valves with external electrical connection



# 5/3-directional valve, Series ES05

- 5/3
- Qn = 0.508 Cv
- closed center
- Compressed air connection output : Ø 8
- Electrical connection : M8x1, 3-pin
- Manual override : without detent
- double solenoid



Activation	Electrically
Working pressure min./max.	44 ... 116 psi
Ambient temperature min./max.	41 ... 122 °F
Medium temperature min./max.	41 ... 122 °F
Medium	Compressed air
Max. particle size	40 µm
Oil content of compressed air	0 ... 5 mg/m <sup>3</sup>
Nominal flow Qn	0.508 Cv
Protection class with connection	IP65
LED status display	Yellow
Duty cycle	100 %

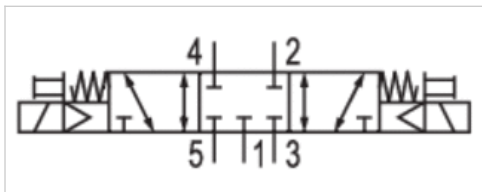

## Technical data

Part No.		Compressed air connection	
		Input	Output
R422103863	closed center	Ø 8	Ø 8

Part No.	Compressed air connection		Operational voltage	Voltage tolerance
	Exhaust			
R422103863	Ø 8		DC 24 V	DC -15% / +10%

Part No.	Power consumption		Switch-on time	Switch-off time
	DC			
R422103863	2 W		20	20

Nominal flow Qn at 87 psi and Δp = 14.5 psi, MO = Manual override

## Technical information

The min. control pressure must be adhered to, since otherwise faulty switching and valve failure may result!  
 The pressure dew point must be at least 27 °F under ambient and medium temperature and may not exceed 5.4 °F .  
 The oil content of compressed air must remain constant during the life cycle.  
 Use only the approved oils from AVENTICS. Further information can be found in the "Technical information" document (available in the MediaCentre).



Exhaust air throttling may only be used in operating lines

## Technical information

Material	
Housing	Polyamide fiber-glass reinforced
Seals	Acrylonitrile butadiene rubber

## Dimensions

double solenoid

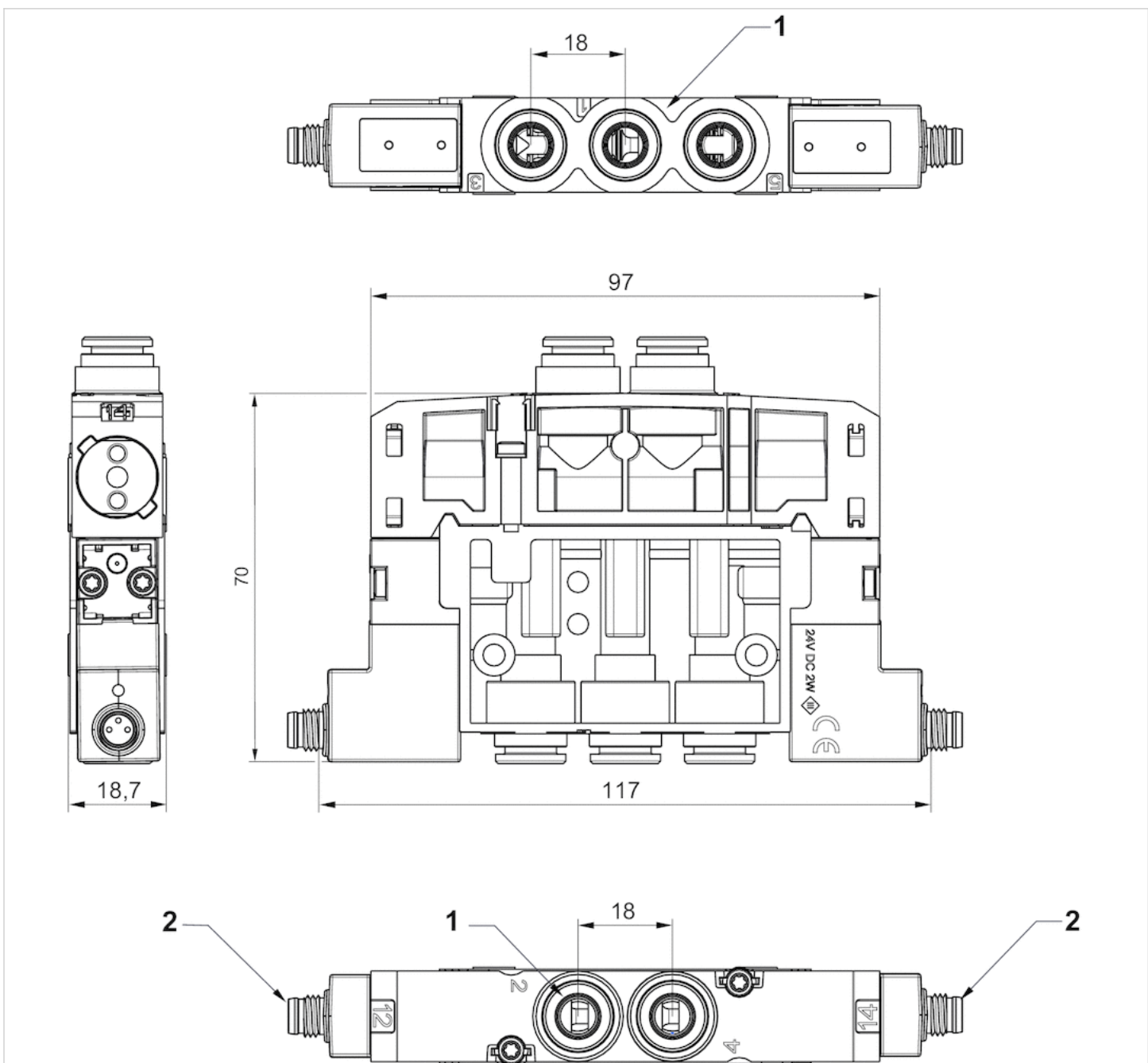

- 1) Connections [ 1 , 3 , 5 , 2 , 4 ] Ø 8
- 2) 2 pilot valves with external electrical connection M8x1

## Pin assignments

### PIN assignment for valve plug connectors

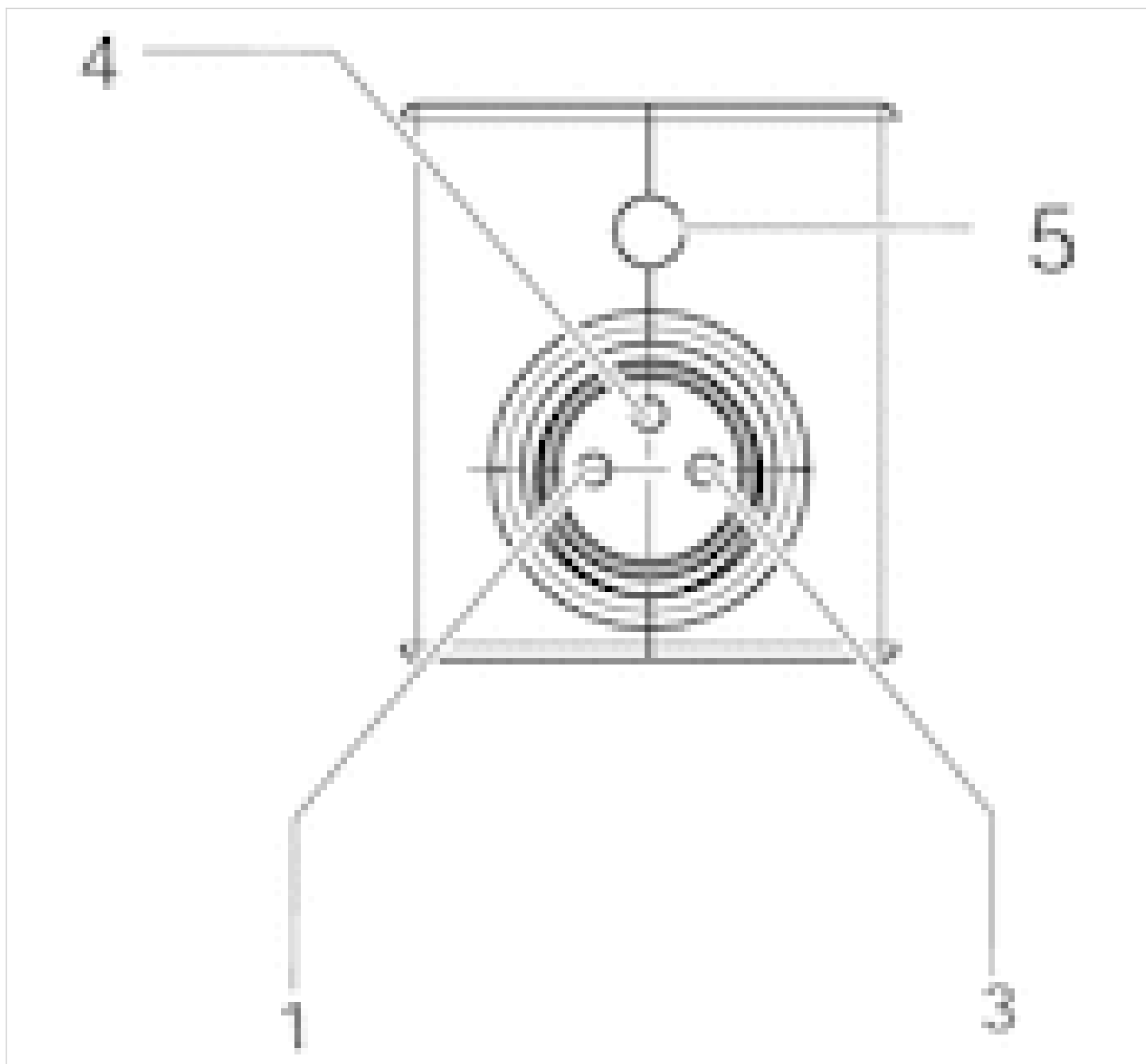

Pin assignment:

- 1) Pin not assigned
- 3) 0 V
- 4) 24 V
- 5) LED

Note: Bi-polar protective circuit to prevent overvoltage



# 2x3/2-directional valve, Series ES05 - inch

- 2x3/2
- $Q_n = 0.376\text{-}0.508\text{ Cv}$
- NC/NC NO/NO
- Compressed air connection output :  $\varnothing 3/8$
- Electrical connection : form C, industry
- Manual override : without detent
- single solenoid



Activation	Electrically
Certificates	UR (Underwriters Laboratories)
Working pressure min./max.	44 ... 116 psi
Ambient temperature min./max.	41 ... 122 °F
Medium temperature min./max.	41 ... 122 °F
Medium	Compressed air
Max. particle size	40 $\mu\text{m}$
Oil content of compressed air	0 ... 5 $\text{mg}/\text{m}^3$
Nominal flow $Q_n$	See table below
Protection class with connection	IP65
Duty cycle	100 %

## Technical data

Part No.			Compressed air connection	
			Input	Output
R422103181		NC/NC	$\varnothing 3/8$	$\varnothing 3/8$
R422103182		NO/NO	$\varnothing 3/8$	$\varnothing 3/8$

Part No.	Compressed air connection		Operational voltage	Voltage tolerance
	Exhaust		DC	DC
R422103181	$\varnothing 3/8$		24 V	-15% / +10%
R422103182	$\varnothing 3/8$		24 V	-15% / +10%

Part No.	Power consumption		Nominal flow $Q_n$	Switch-on time	Switch-off time
	DC				
R422103181	2 W		0.508 Cv	20	20
R422103182	2 W		0.376 Cv	20	20

Nominal flow  $Q_n$  at 87 psi and  $\Delta p = 14.5$  psi

## Technical information

The min. control pressure must be adhered to, since otherwise faulty switching and valve failure may result!

The pressure dew point must be at least 27 °F under ambient and medium temperature and may not exceed 5.4 °F .

The oil content of compressed air must remain constant during the life cycle.

Use only the approved oils from AVENTICS. Further information can be found in the "Technical information" document (available in the MediaCentre).

The pilot valve is UL (Underwriters Laboratories) certified.

Exhaust air throttling may only be used in operating lines

## Technical information

Material	
Housing	Polyamide fiber-glass reinforced
Seals	Acrylonitrile butadiene rubber

## Dimensions

### Dimensions

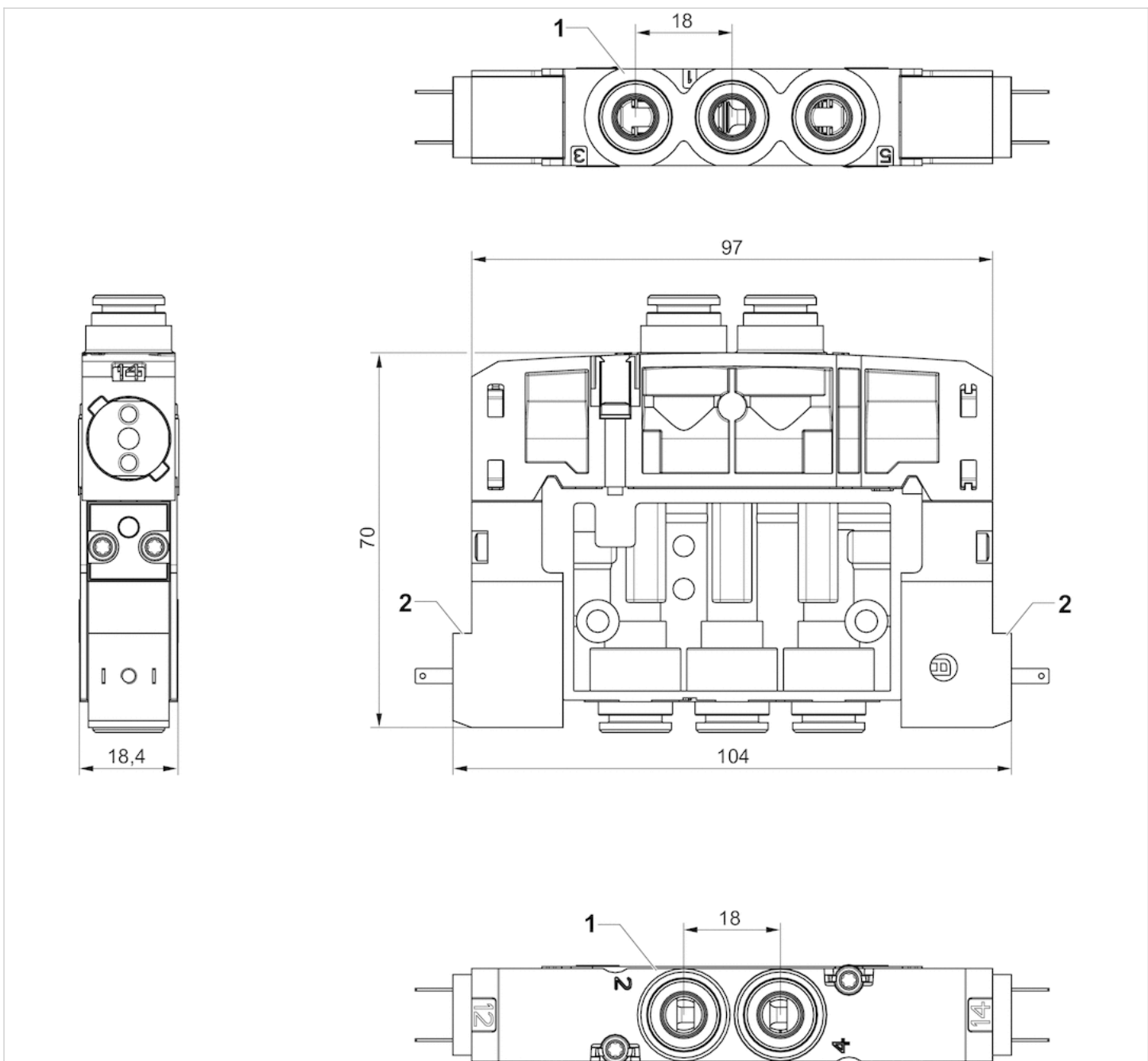

- 1) Connections [1, 3, 5, 2, 4] Ø 3/8
- 2) 2 pilot valves with external electrical connection





# 2x3/2-directional valve, Series ES05 - inch

- 2x3/2
- $Q_n = 0.376-0.508 \text{ Cv}$
- NC/NC NO/NO
- Compressed air connection output :  $\varnothing 3/8$
- Electrical connection : M8x1, 3-pin
- Manual override : without detent
- single solenoid



Activation	Electrically
Working pressure min./max.	44 ... 116 psi
Ambient temperature min./max.	41 ... 122 °F
Medium temperature min./max.	41 ... 122 °F
Medium	Compressed air
Max. particle size	40 $\mu\text{m}$
Oil content of compressed air	0 ... 5 $\text{mg}/\text{m}^3$
Nominal flow $Q_n$	See table below
Protection class with connection	IP65
Duty cycle	100 %

## Technical data

Part No.			Compressed air connection	
			Input	Output
R422103861		NC/NC	$\varnothing 3/8$	$\varnothing 3/8$
R422103862		NO/NO	$\varnothing 3/8$	$\varnothing 3/8$

Part No.	Compressed air connection		Operational voltage	Voltage tolerance
	Exhaust			
R422103861	$\varnothing 3/8$		DC 24 V	DC -15% / +10%
R422103862	$\varnothing 3/8$		DC 24 V	DC -15% / +10%

Part No.	Power consumption		Nominal flow $Q_n$	Switch-on time	Switch-off time
	DC				
R422103861	2 W		0.508 Cv	20	20
R422103862	2 W		0.376 Cv	20	20

Nominal flow  $Q_n$  at 87 psi and  $\Delta p = 14.5 \text{ psi}$

## Technical information

The min. control pressure must be adhered to, since otherwise faulty switching and valve failure may result!

The pressure dew point must be at least 27 °F under ambient and medium temperature and may not exceed 5.4 °F .

The oil content of compressed air must remain constant during the life cycle.

Use only the approved oils from AVENTICS. Further information can be found in the "Technical information" document (available in the MediaCentre).

Exhaust air throttling may only be used in operating lines

## Technical information

Material	
Housing	Polyamide fiber-glass reinforced
Seals	Acrylonitrile butadiene rubber

## Dimensions

### Dimensions

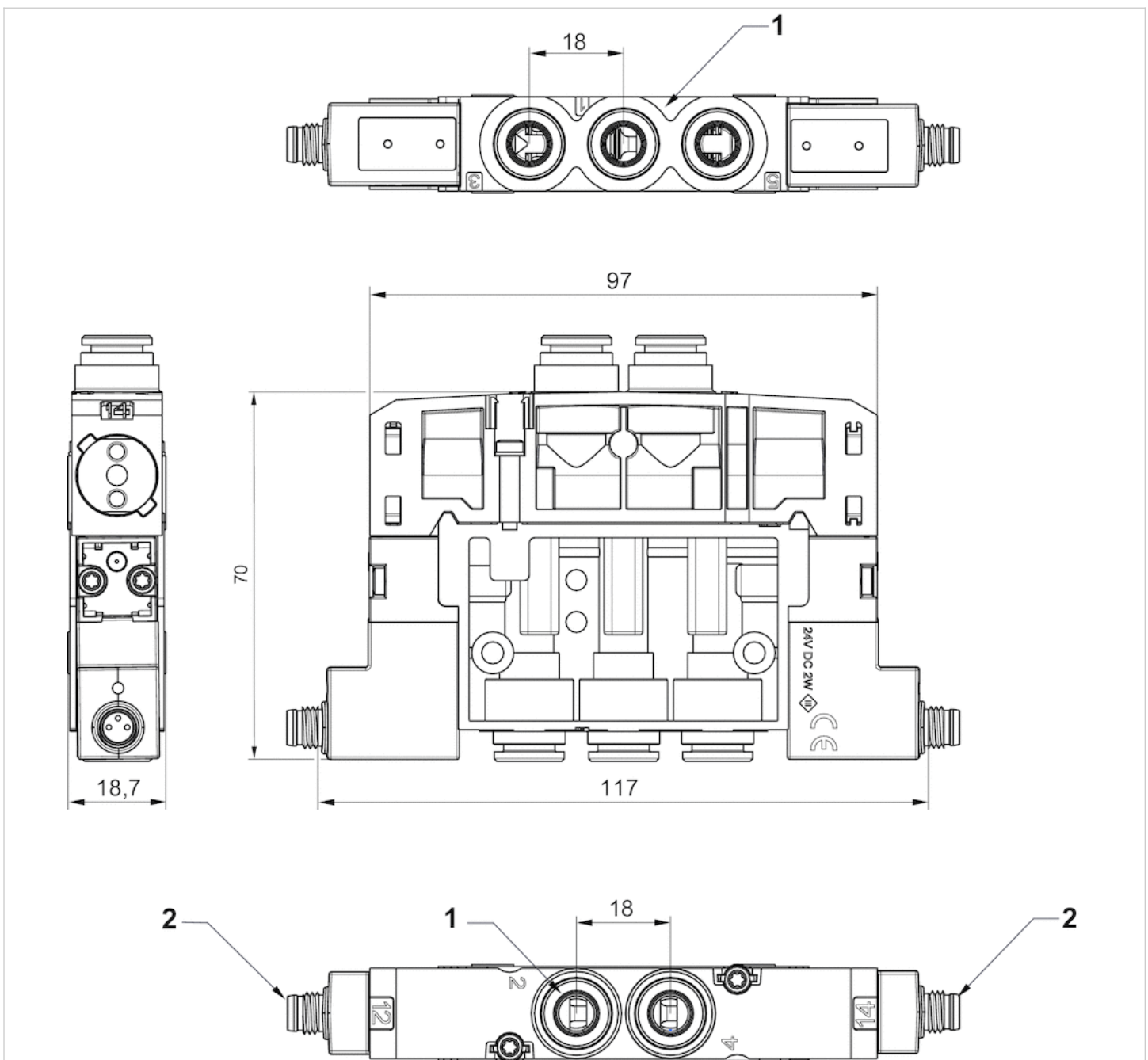

- 1) Connections [1, 3, 5, 2, 4] Ø 8
- 2) 1 pilot valve with electrical connection M8x1

## Pin assignments

### PIN assignment for valve plug connectors

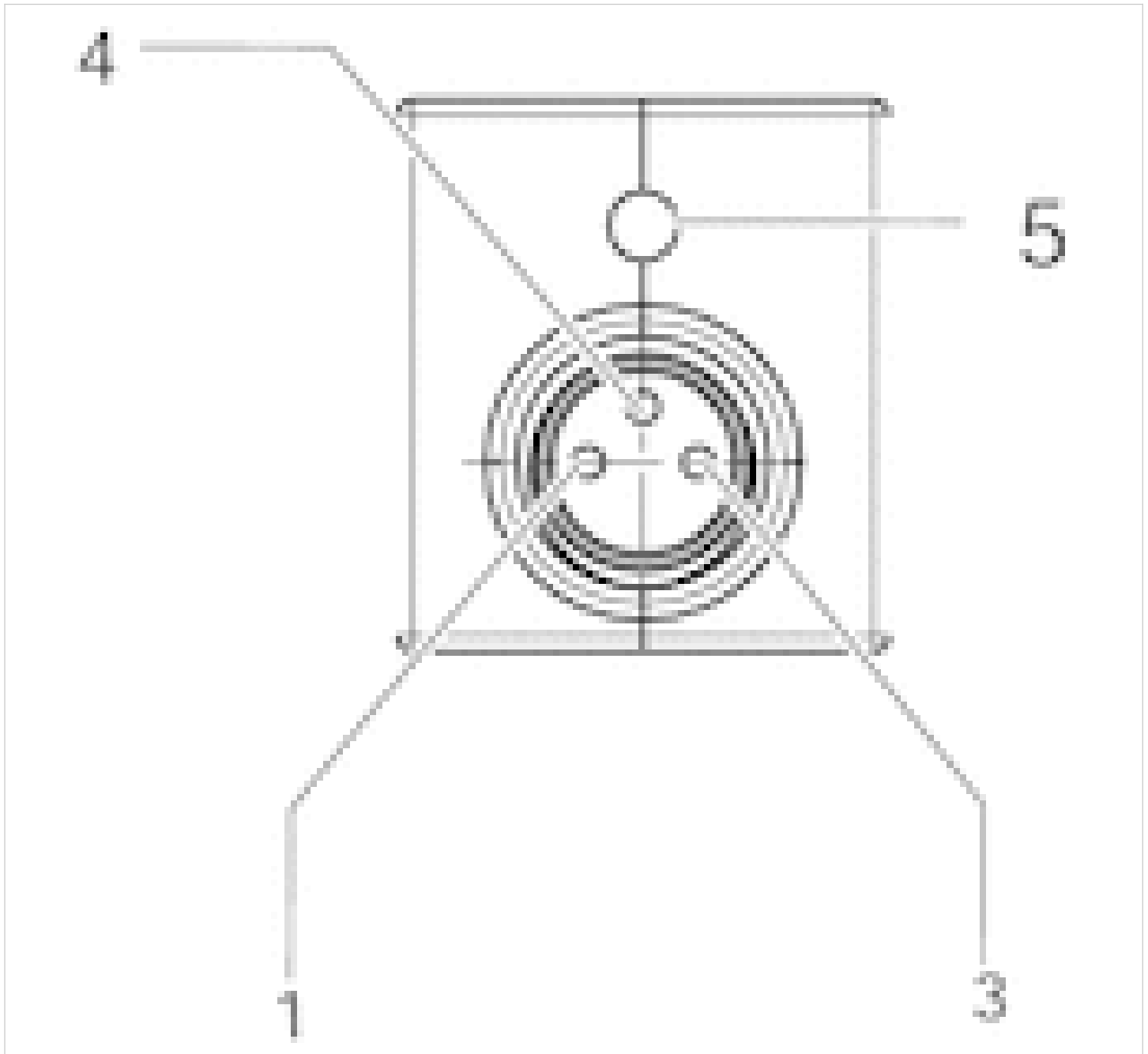

Pin assignment:

- 1) Pin not assigned
- 3) 0 V
- 4) 24 V
- 5) LED

Note: Bi-polar protective circuit to prevent overvoltage





# 5/2-directional valve, Series ES05 -inch

- 5/2
- $Q_n = 0.62 \text{ Cv}$
- Compressed air connection output :  $\text{Ø } 3/8$
- Electrical connection : form C, industry
- Manual override : without detent
- single solenoid double solenoid



Activation	Electrically
Certificates	UR (Underwriters Laboratories)
Working pressure min./max.	44 ... 116 psi
Ambient temperature min./max.	41 ... 122 °F
Medium temperature min./max.	41 ... 122 °F
Medium	Compressed air
Max. particle size	40 $\mu\text{m}$
Oil content of compressed air	0 ... 5 $\text{mg/m}^3$
Nominal flow $Q_n$	0.62 Cv
Protection class with connection	IP65
Duty cycle	100 %

## Technical data

Part No.		Compressed air connection	
		Input	Output
R422103179		$\text{Ø } 3/8$	$\text{Ø } 3/8$
R422103180		$\text{Ø } 3/8$	$\text{Ø } 3/8$

Part No.	Compressed air connection		Operational voltage	Voltage tolerance
	Exhaust			
R422103179	$\text{Ø } 3/8$		DC	DC
R422103180	$\text{Ø } 3/8$		24 V	-15% / +10%

Part No.	Power consumption		Switch-on time	Switch-off time	Fig.
	DC				
R422103179	2 W		20	35	Fig. 1
R422103180	2 W		20	20	Fig. 2

Nominal flow  $Q_n$  at 87 psi and  $\Delta p = 14.5 \text{ psi}$

## Technical information

The min. control pressure must be adhered to, since otherwise faulty switching and valve failure may result!  
 The pressure dew point must be at least 27 °F under ambient and medium temperature and may not exceed 5.4 °F .  
 The oil content of compressed air must remain constant during the life cycle.  
 The pilot valve is UL (Underwriters Laboratories) certified.  
 Exhaust air throttling may only be used in operating lines

## Technical information

### Material

Housing	Polyamide fiber-glass reinforced
Seals	Acrylonitrile butadiene rubber

## Dimensions

Fig. 1, single solenoid

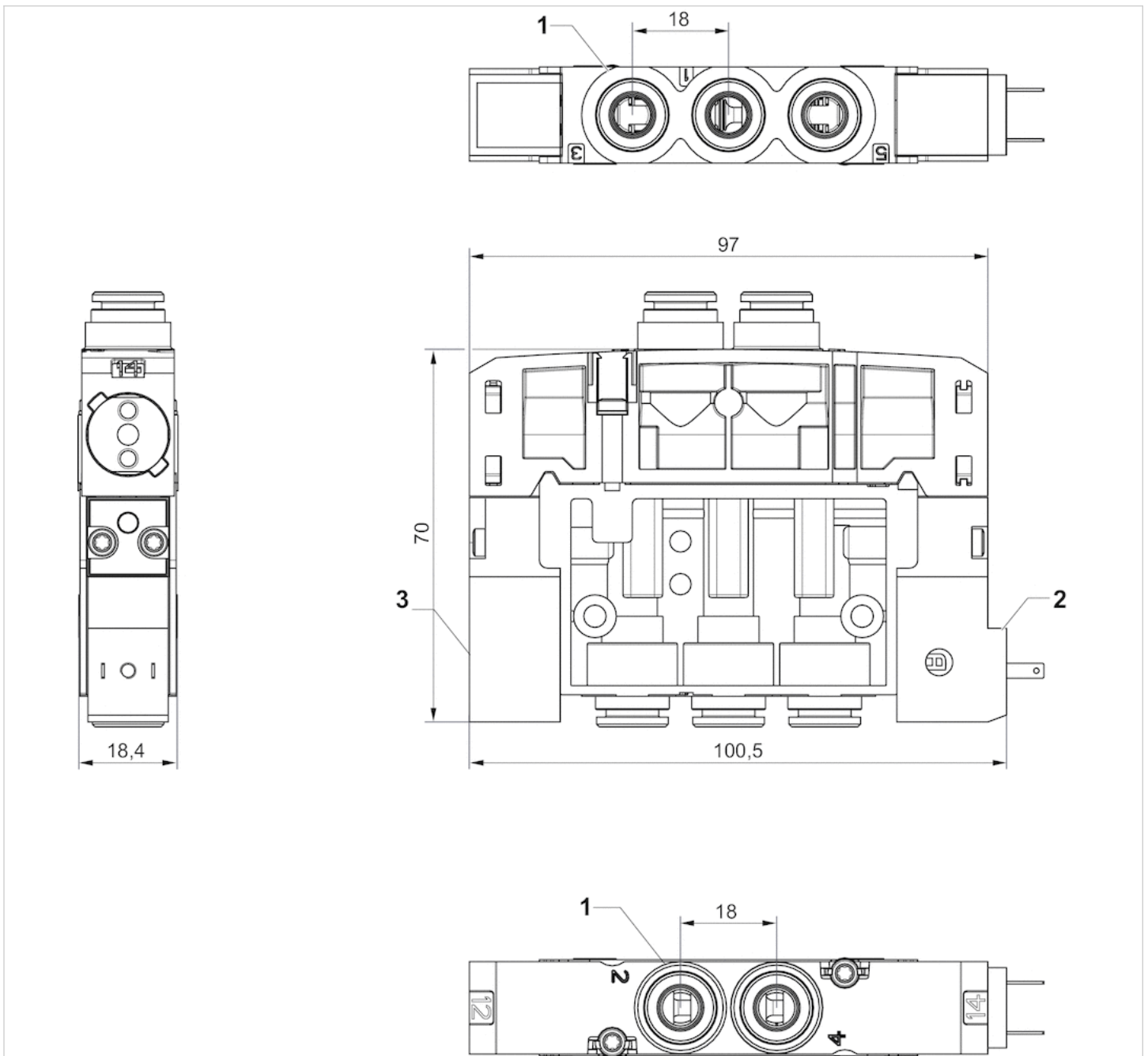

- 1) Connections [1 ,3 ,5, 2, 4] Ø 3/8
- 2) 1 pilot valve with electrical connection
- 3) Pilot blanking plate

Fig. 2, double solenoid

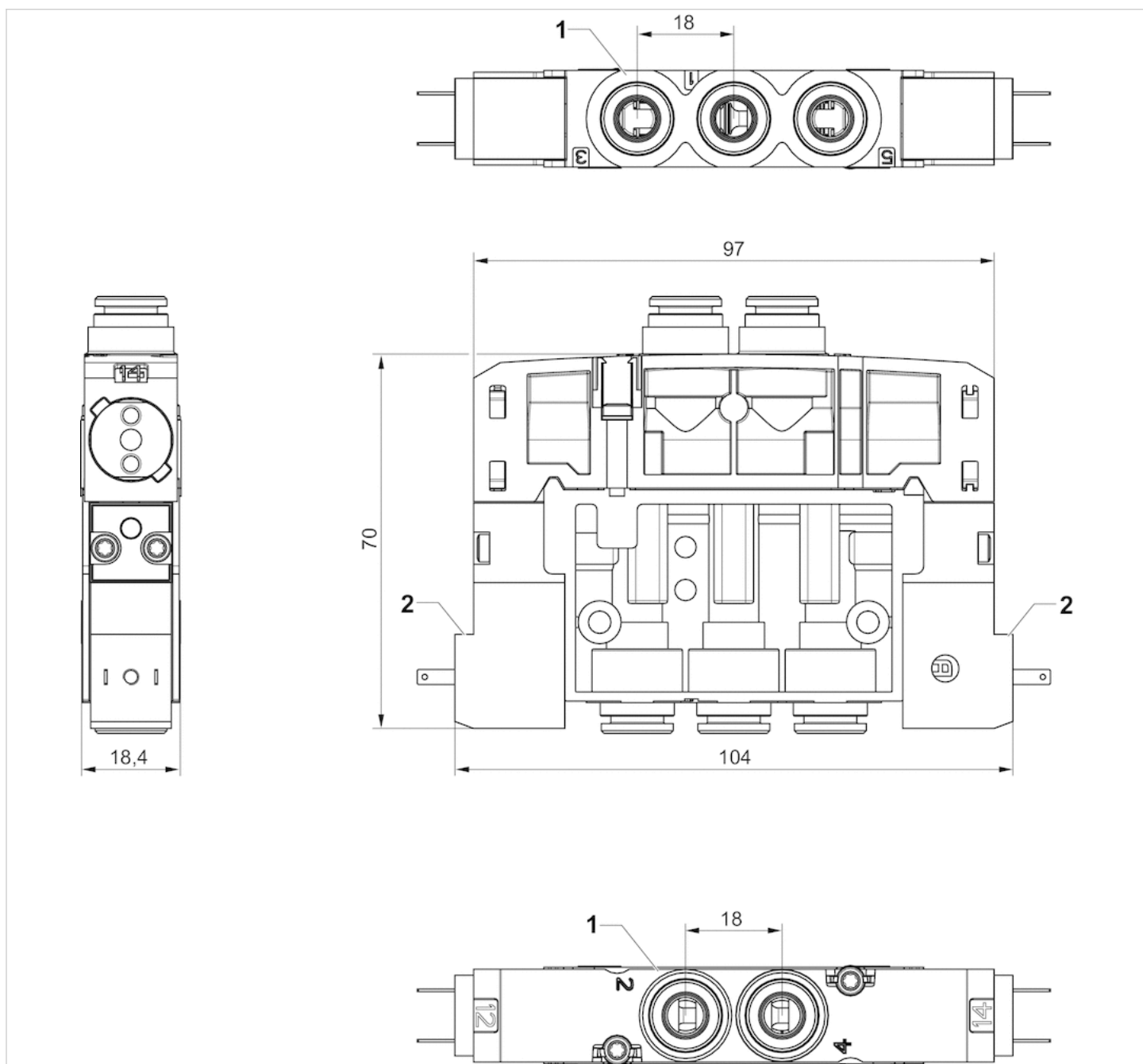

- 1) Connections [1 ,3 ,5, 2, 4] Ø 3/8
- 2) 2 pilot valves with external electrical connection



# 5/2-directional valve, Series ES05 -inch

- 5/2
- $Q_n = 0.62 \text{ Cv}$
- Compressed air connection output :  $\varnothing 3/8$
- Electrical connection : M8x1, 3-pin
- Manual override : without detent
- single solenoid double solenoid



Activation	Electrically
Working pressure min./max.	44 ... 116 psi
Ambient temperature min./max.	41 ... 122 °F
Medium temperature min./max.	41 ... 122 °F
Medium	Compressed air
Max. particle size	40 $\mu\text{m}$
Oil content of compressed air	0 ... 5 $\text{mg}/\text{m}^3$
Nominal flow $Q_n$	0.62 Cv
Protection class with connection	IP65
Duty cycle	100 %

## Technical data

Part No.		Compressed air connection	
		Input	Output
R422103859		$\varnothing 3/8$	$\varnothing 3/8$
R422103860		$\varnothing 3/8$	$\varnothing 3/8$

Part No.	Compressed air connection		Operational voltage	Voltage tolerance
	Exhaust			
R422103859	$\varnothing 3/8$		DC	DC
R422103860	$\varnothing 3/8$		24 V	-15% / +10%

Part No.	Power consumption		Switch-on time	Switch-off time	Fig.
	DC				
R422103859	2 W		20	35	Fig. 1
R422103860	2 W		20	20	Fig. 2

Nominal flow  $Q_n$  at 87 psi and  $\Delta p = 14.5 \text{ psi}$

## Technical information

The min. control pressure must be adhered to, since otherwise faulty switching and valve failure may result!  
 The pressure dew point must be at least 27 °F under ambient and medium temperature and may not exceed 5.4 °F .  
 The oil content of compressed air must remain constant during the life cycle.  
 Exhaust air throttling may only be used in operating lines

## Technical information

Material	
Housing	Polyamide fiber-glass reinforced
Seals	Acrylonitrile butadiene rubber

## Dimensions

Fig. 1, single solenoid

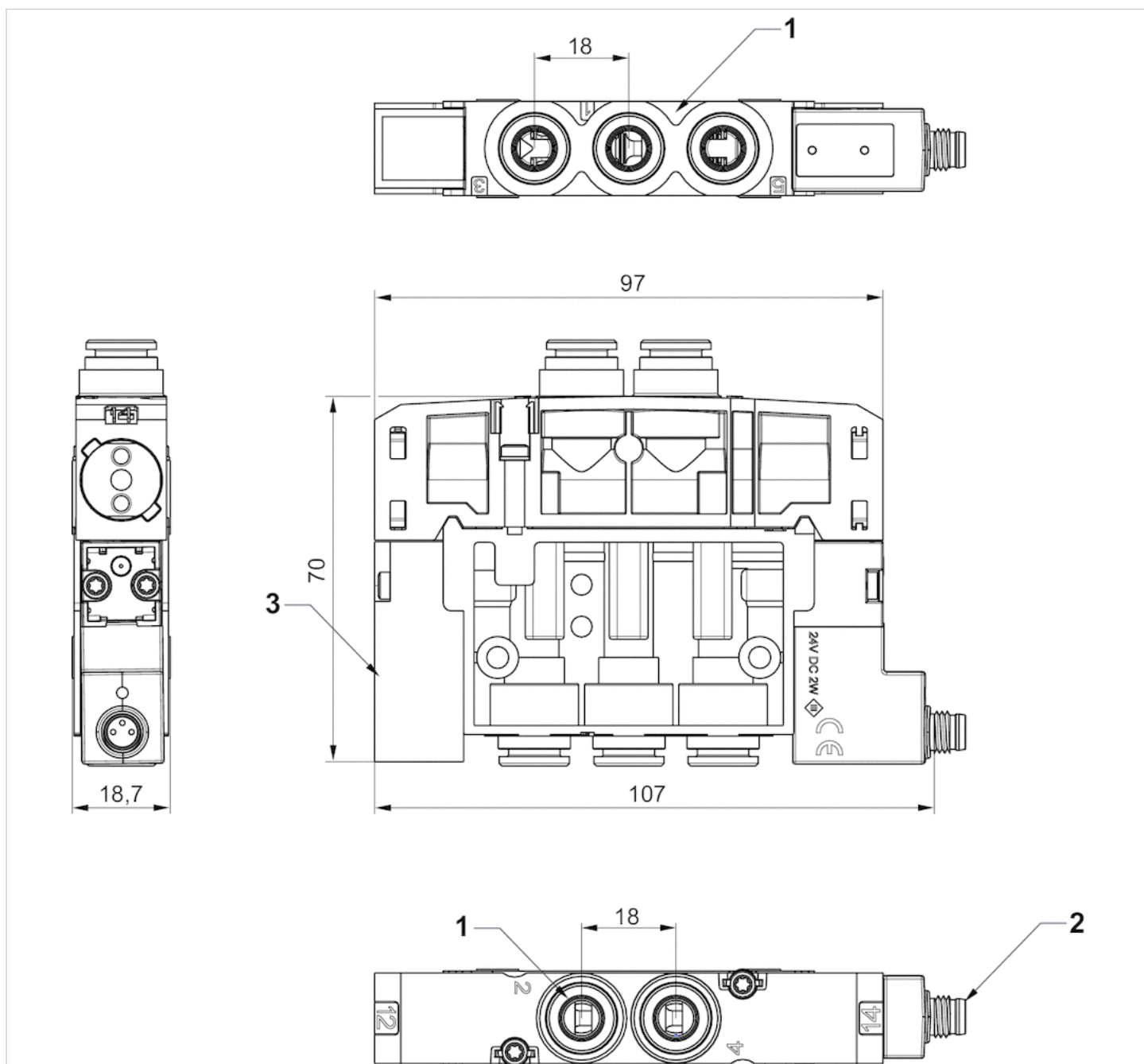

- 1) Connections [ 1 , 3 , 5 , 2 , 4 ] Ø 3/8
- 2) 2 pilot valves with external electrical connection M8x1
- 3) Pilot blanking plate

Fig. 2, double solenoid

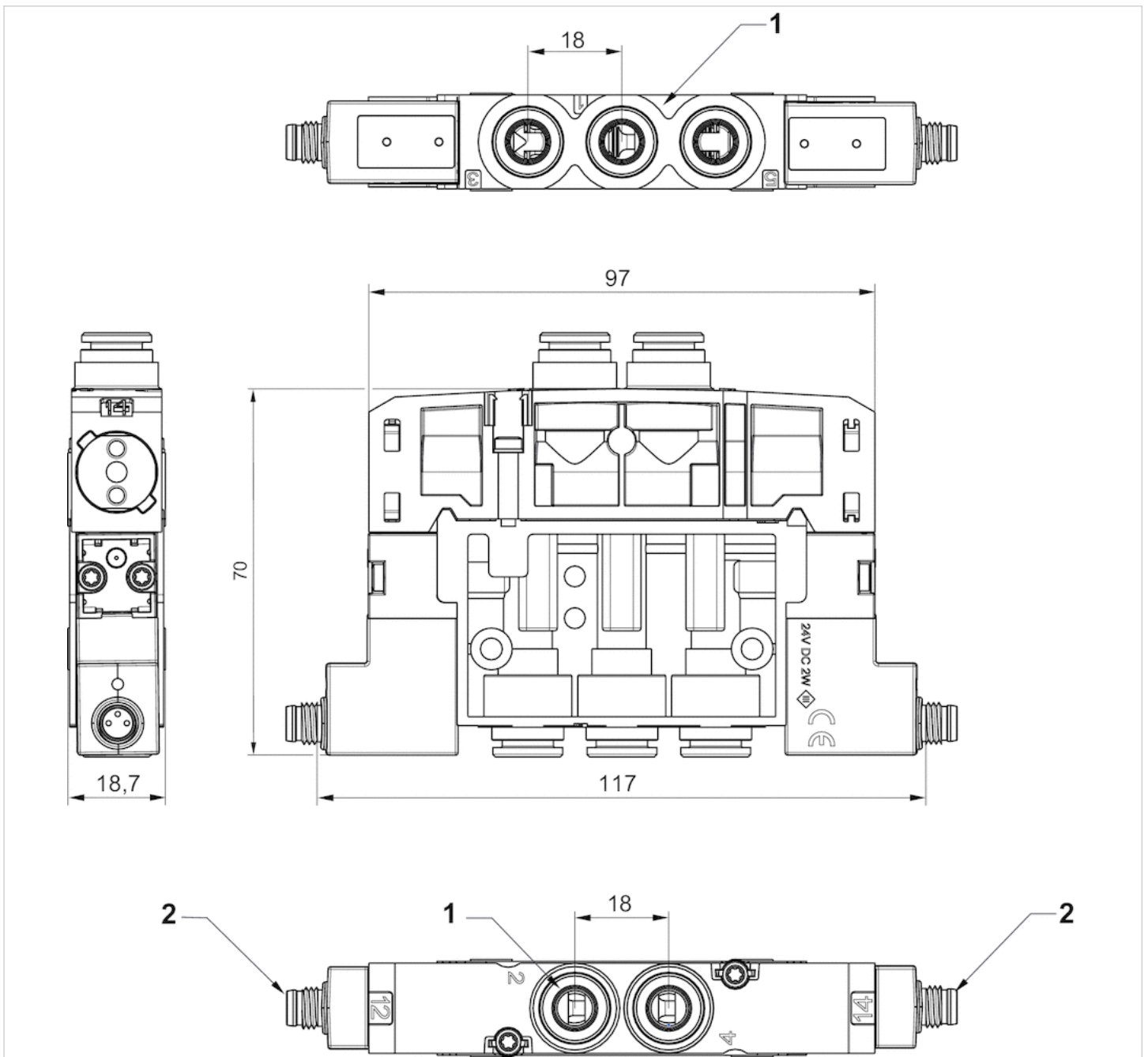

- 1) Connections [1 ,3 ,5, 2, 4] Ø 3/8
- 2) 2 pilot valves with external electrical connection M8x1

## Pin assignments

### PIN assignment for valve plug connectors

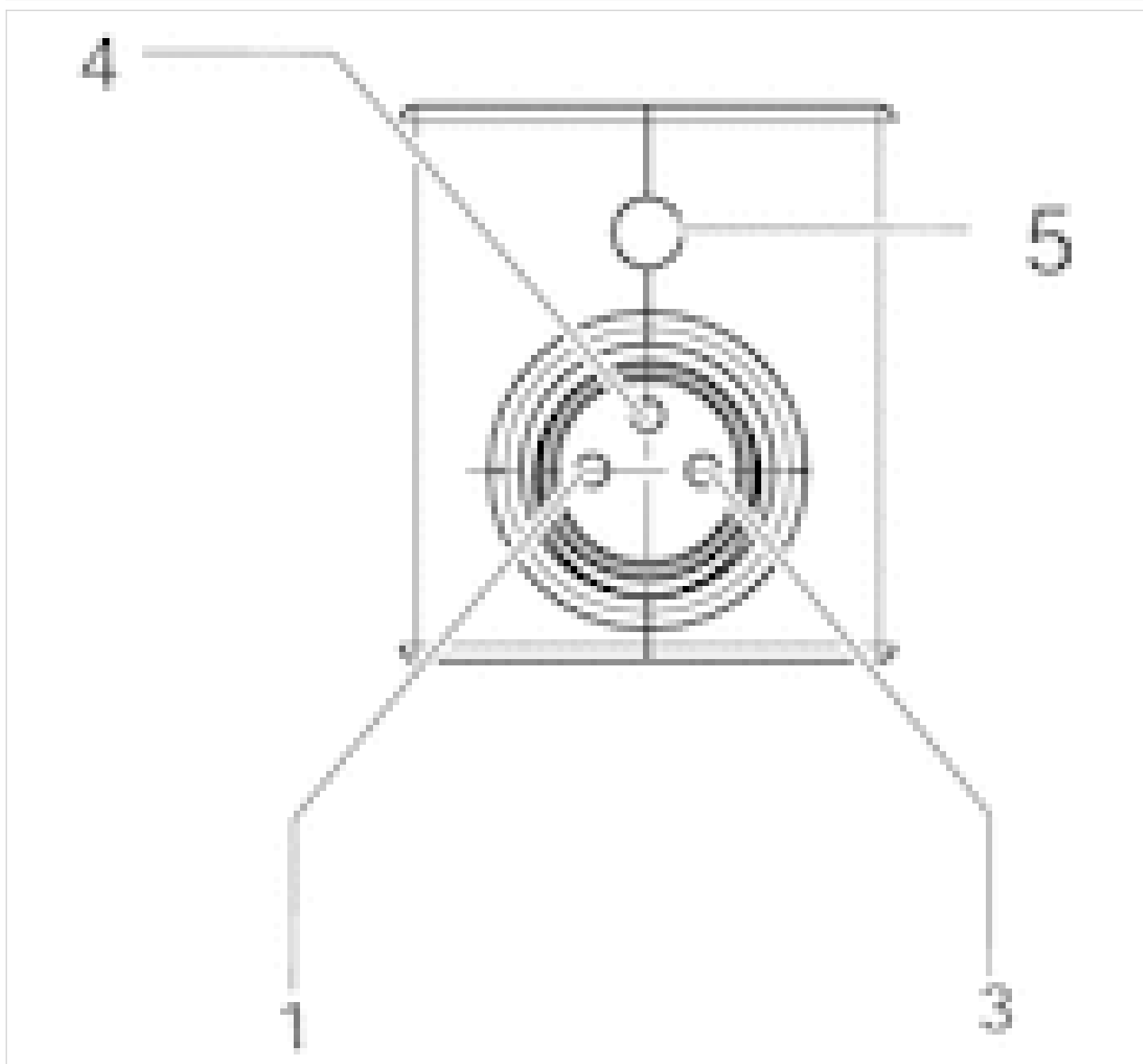

Pin assignment:

- 1) Pin not assigned
- 3) 0 V
- 4) 24 V
- 5) LED

Note: Bi-polar protective circuit to prevent overvoltage

# 5/3-directional valve, Series ES05 -inch

- 5/3
- $Q_n = 0.508 \text{ Cv}$
- Compressed air connection output :  $\text{Ø } 3/8$
- Electrical connection : form C, industry
- double solenoid



Activation	Electrically
Certificates	UR (Underwriters Laboratories)
Working pressure min./max.	44 ... 116 psi
Ambient temperature min./max.	41 ... 122 °F
Medium temperature min./max.	41 ... 122 °F
Medium	Compressed air
Max. particle size	40 $\mu\text{m}$
Oil content of compressed air	0 ... 5 $\text{mg/m}^3$
Nominal flow $Q_n$	0.508 Cv
Protection class with connection	IP65
LED status display	Yellow
Duty cycle	100 %

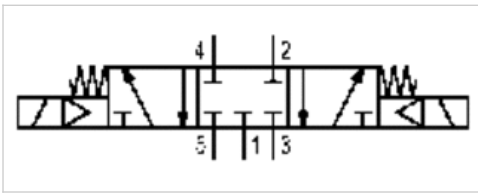

## Technical data

Part No.	Compressed air connection	
	Input	Output
R422103184	$\text{Ø } 3/8$	$\text{Ø } 3/8$

Part No.	Compressed air connection		Operational voltage	Voltage tolerance
	Exhaust			
R422103184	$\text{Ø } 3/8$		DC 24 V	DC -15% / +10%

Part No.	Power consumption	
	DC	
R422103184	2 W	

Nominal flow  $Q_n$  at 87 psi and  $\Delta p = 14.5 \text{ psi}$

## Technical information

The min. control pressure must be adhered to, since otherwise faulty switching and valve failure may result!  
 The pressure dew point must be at least 27 °F under ambient and medium temperature and may not exceed 5.4 °F .  
 The oil content of compressed air must remain constant during the life cycle.  
 Use only the approved oils from AVENTICS. Further information can be found in the "Technical information" document (available in the MediaCentre).  
 The pilot valve is UL (Underwriters Laboratories) certified.  
 Exhaust air throttling may only be used in operating lines



## Technical information

### Material

Housing	Polyamide fiber-glass reinforced
Seals	Acrylonitrile butadiene rubber

## Dimensions

### double solenoid

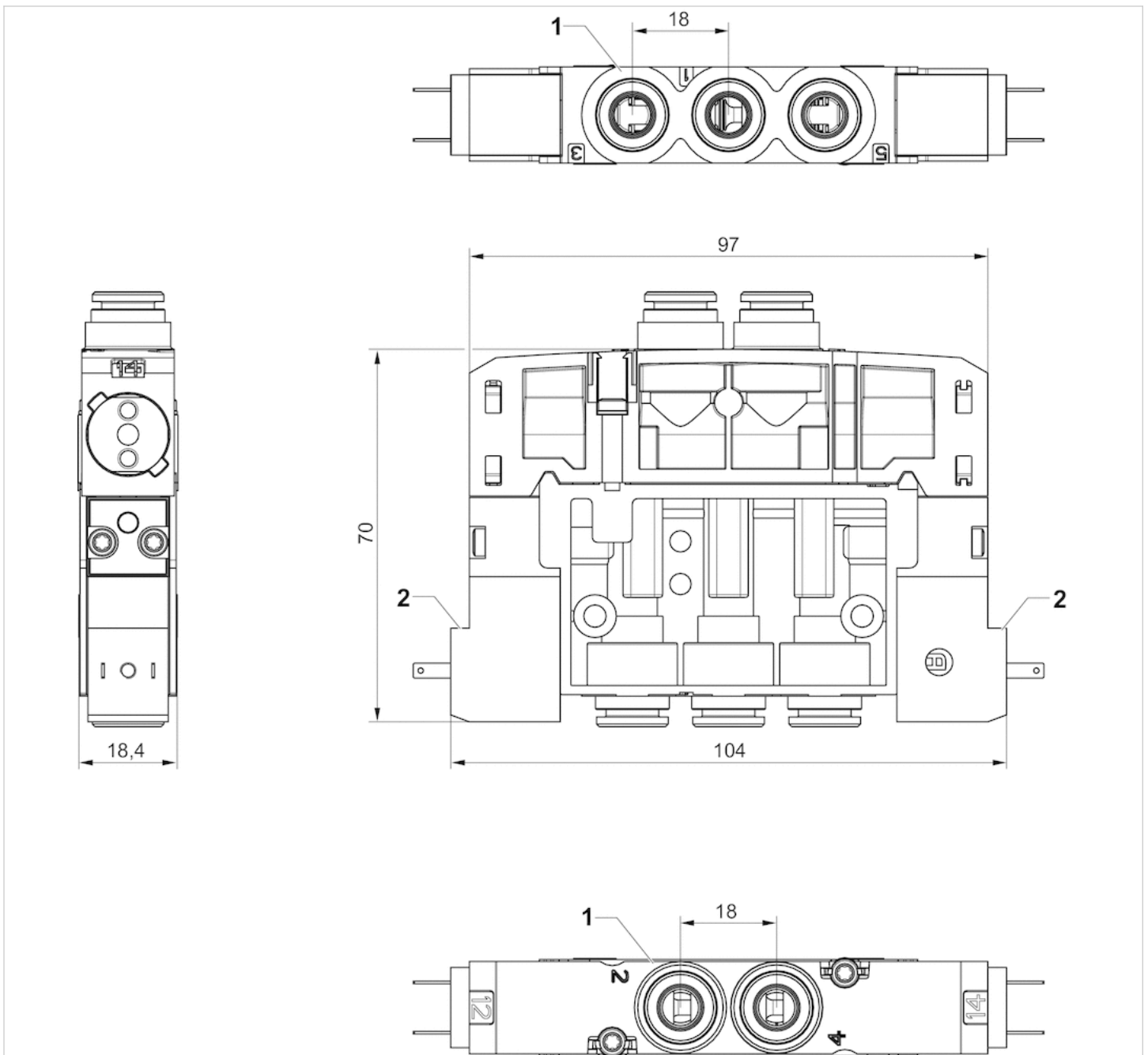

- 1) Connections [1 ,3 ,5, 2, 4] Ø 3/8
- 2) 2 pilot valves with external electrical connection

# 5/3-directional valve, Series ES05 -inch

- 5/3
- $Q_n = 0.508 \text{ Cv}$
- Compressed air connection output :  $\varnothing 3/8$
- Electrical connection : M8x1, 3-pin
- Manual override : without detent
- double solenoid



Activation	Electrically
Working pressure min./max.	44 ... 116 psi
Ambient temperature min./max.	41 ... 122 °F
Medium temperature min./max.	41 ... 122 °F
Medium	Compressed air
Max. particle size	40 $\mu\text{m}$
Oil content of compressed air	0 ... 5 $\text{mg}/\text{m}^3$
Nominal flow $Q_n$	0.508 Cv
Protection class with connection	IP65
LED status display	Yellow
Duty cycle	100 %

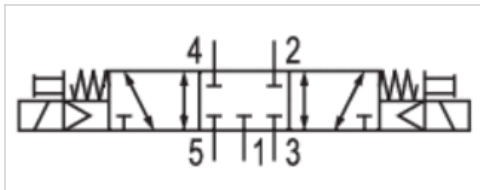

## Technical data

Part No.	Compressed air connection	
	Input	Output
R422103864	$\varnothing 3/8$	$\varnothing 3/8$

Part No.	Compressed air connection		Operational voltage	Voltage tolerance
	Exhaust			
R422103864	$\varnothing 3/8$		DC 24 V	DC -10% / +15%

Part No.	Power consumption		Switch-on time	Switch-off time
	DC			
R422103864	2 W		20	20

Nominal flow  $Q_n$  at 87 psi and  $\Delta p = 14.5 \text{ psi}$ , MO = Manual override

## Technical information

The min. control pressure must be adhered to, since otherwise faulty switching and valve failure may result!  
 The pressure dew point must be at least 27 °F under ambient and medium temperature and may not exceed 5.4 °F .  
 The oil content of compressed air must remain constant during the life cycle.  
 Use only the approved oils from AVENTICS. Further information can be found in the "Technical information" document (available in the MediaCentre).

Exhaust air throttling may only be used in operating lines

## Technical information

Material	
Housing	Polyamide fiber-glass reinforced
Seals	Acrylonitrile butadiene rubber

## Dimensions

### Dimensions, double solenoid

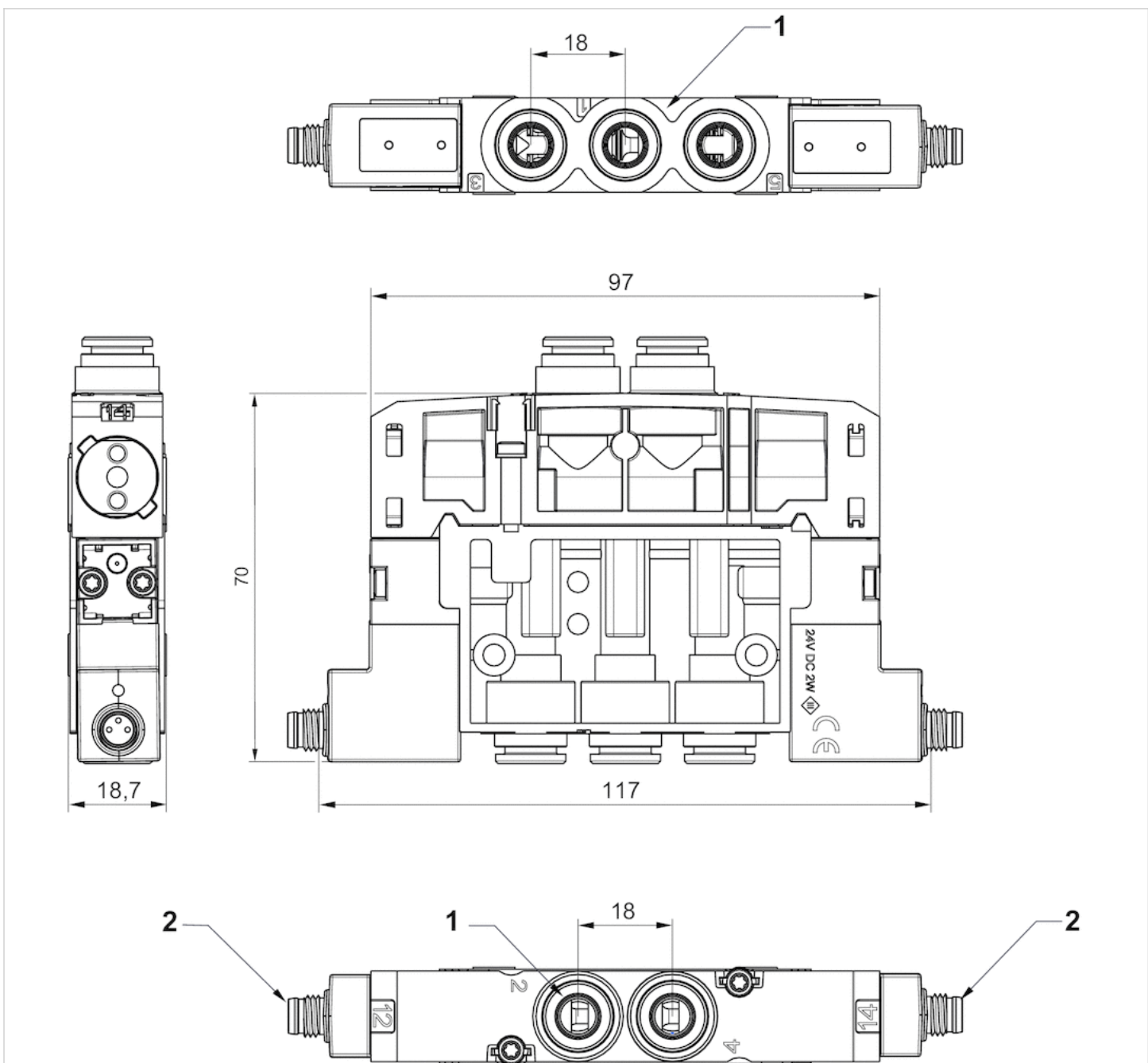

- 1) Connections [ 1 , 3 , 5 , 2 , 4 ] Ø 3/8
- 2) 2 pilot valves with external electrical connection M8x1

## Pin assignments

### PIN assignment for valve plug connectors

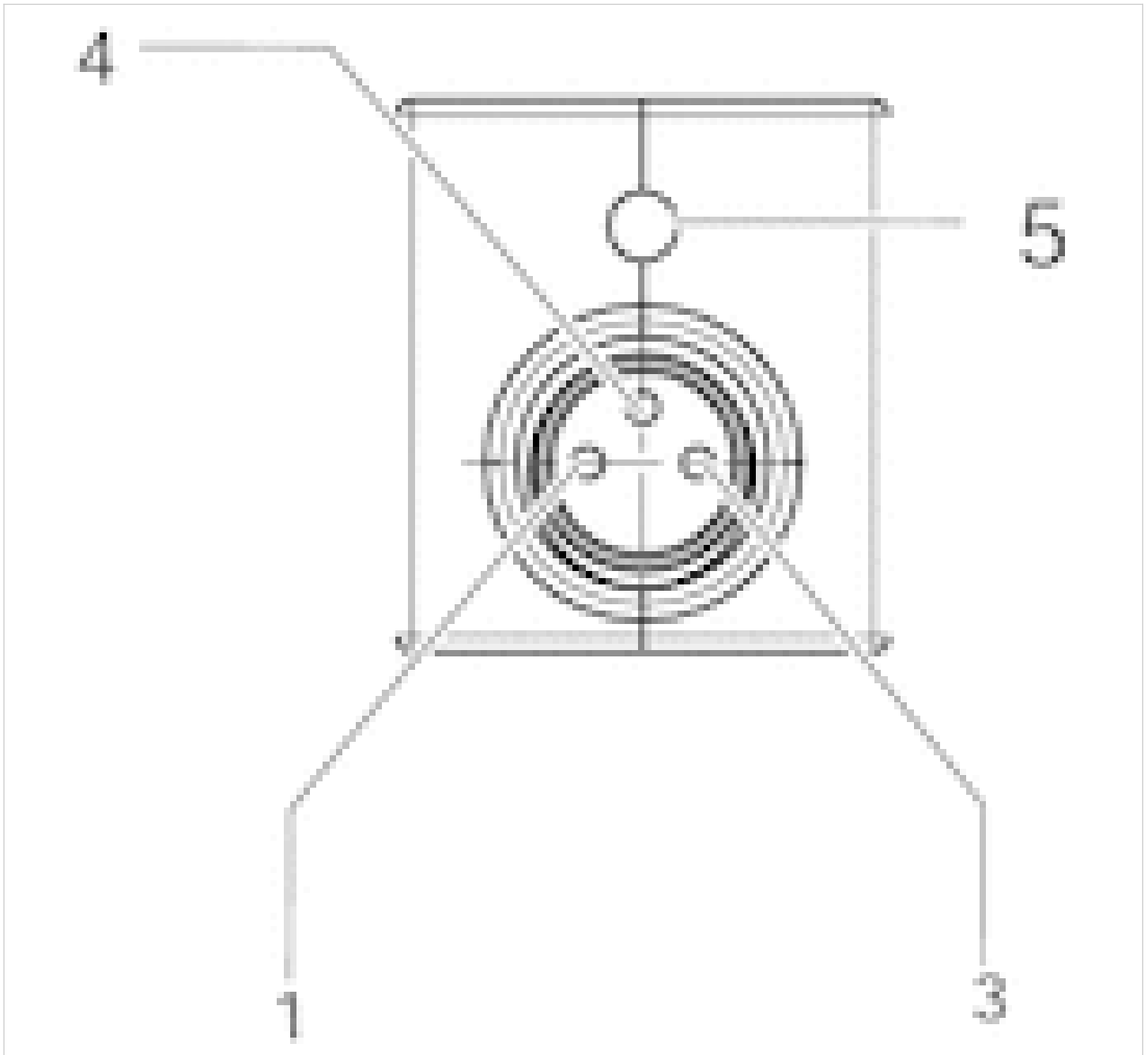

Pin assignment:

- 1) Pin not assigned
- 3) 0 V
- 4) 24 V
- 5) LED

Note: Bi-polar protective circuit to prevent overvoltage





# 2x 3/2 directional valve function, Series ES05

- 2x3/2
- $Q_n = 0.376-0.508 \text{ Cv}$
- NO/NO NC/NC
- Compressed air connection output :  $\varnothing 8$
- Manual override : without detent
- single solenoid
- With spring return



Activation	Electrically
Working pressure min./max.	-11 ... 116 psi
Control pressure min./max.	44 ... 116 psi
Ambient temperature min./max.	41 ... 122 °F
Medium temperature min./max.	41 ... 122 °F
Medium	Compressed air
Max. particle size	40 $\mu\text{m}$
Oil content of compressed air	0 ... 5 mg/m <sup>3</sup>
Nominal flow $Q_n$	See table below
mounting screws	Hexalobular socket (TORX) ISO 10664-10
Mounting screw tightening torque	0.664 ft./lbs.
Tightening torque tolerance	$\pm 0,1 \text{ mT}$

## Technical data

Part No.			Compressed air connection	
			Input	Output
R422102638		NO/NO	Base plate	$\varnothing 8$
R422P02638		NO/NO	Base plate	$\varnothing 8$
R422102637		NC/NC	Base plate	$\varnothing 8$
R422P02637		NC/NC	Base plate	$\varnothing 8$

Part No.	Nominal flow $Q_n$	Switch-on time	Switch-off time	Delivery unit
R422102638	0.376 Cv	20	20	1 piece
R422P02638	0.376 Cv	20	20	5 piece
R422102637	0.508 Cv	20	20	1 piece
R422P02637	0.508 Cv	20	20	5 piece

Nominal flow  $Q_n$  at 87 psi and  $\Delta p = 14.5 \text{ psi}$

## Technical information

The min. control pressure must be adhered to, since otherwise faulty switching and valve failure may result!  
 The pressure dew point must be at least 27 °F under ambient and medium temperature and may not exceed 5.4 °F .  
 The oil content of compressed air must remain constant during the life cycle.  
 Use only the approved oils from AVENTICS. Further information can be found in the "Technical information" document (available in the MediaCentre).

## Technical information

Material	
Housing	Polyamide Polyoxymethylene
Seals	Acrylonitrile butadiene rubber

## Dimensions

### Dimensions

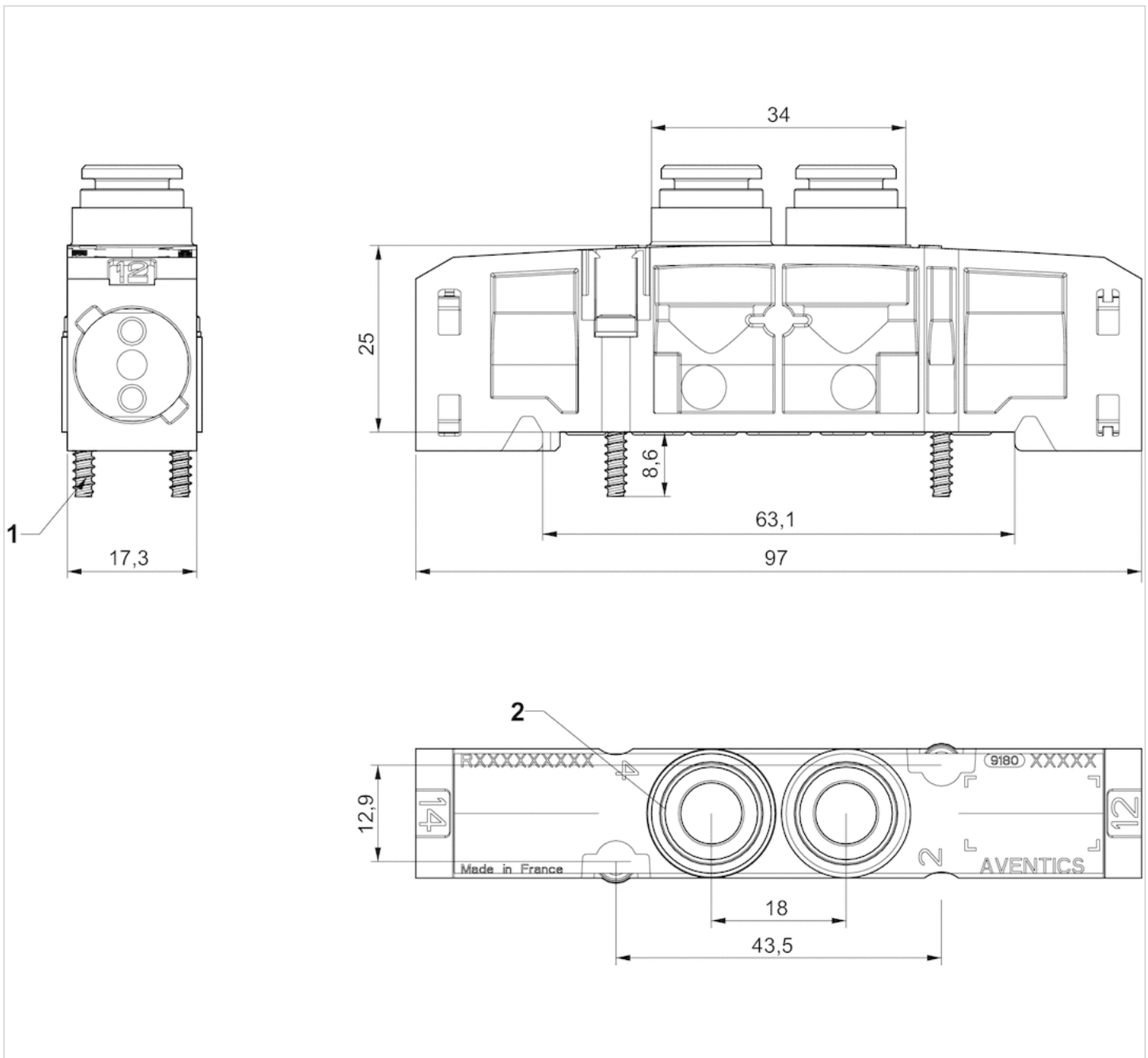

- 1) Screws for plastic Ø3
- 2) Ø 8





# 5/2 directional valve function, Series ES05

- 5/2
- $Q_n = 0.62 \text{ Cv}$
- Compressed air connection output :  $\varnothing 8$
- single solenoid double solenoid
- With spring return



Activation	Electrically
Working pressure min./max.	-11 ... 116 psi
Control pressure min./max.	44 ... 116 psi
Ambient temperature min./max.	41 ... 122 °F
Medium temperature min./max.	41 ... 122 °F
Medium	Compressed air
Max. particle size	40 $\mu\text{m}$
Oil content of compressed air	0 ... 5 $\text{mg/m}^3$
Nominal flow $Q_n$	0.62 Cv
mounting screws	Hexalobular socket (TORX) ISO 10664-10
Mounting screw tightening torque	0.664 ft./lbs.
Tightening torque tolerance	$\pm 0,1 \text{ mT}$

## Technical data

Part No.		Compressed air connection		Switch-on time
		Input	Output	
R422102601		Base plate	$\varnothing 8$	20
R422P02601		Base plate	$\varnothing 8$	20
R422102636		Base plate	$\varnothing 8$	20
R422P02636		Base plate	$\varnothing 8$	20

Part No.	Switch-off time	Delivery unit
R422102601	35	1 piece
R422P02601	35	5 piece
R422102636	20	1 piece
R422P02636	20	5 piece

Nominal flow  $Q_n$  at 87 psi and  $\Delta p = 14.5 \text{ psi}$

## Technical information

The min. control pressure must be adhered to, since otherwise faulty switching and valve failure may result!

The pressure dew point must be at least 27 °F under ambient and medium temperature and may not exceed 5.4 °F .

The oil content of compressed air must remain constant during the life cycle.

Use only the approved oils from AVENTICS. Further information can be found in the "Technical information" document (available in the MediaCentre).

## Technical information

Material	
Housing	Polyamide Polyoxymethylene
Seals	Acrylonitrile butadiene rubber

## Dimensions

### Dimensions

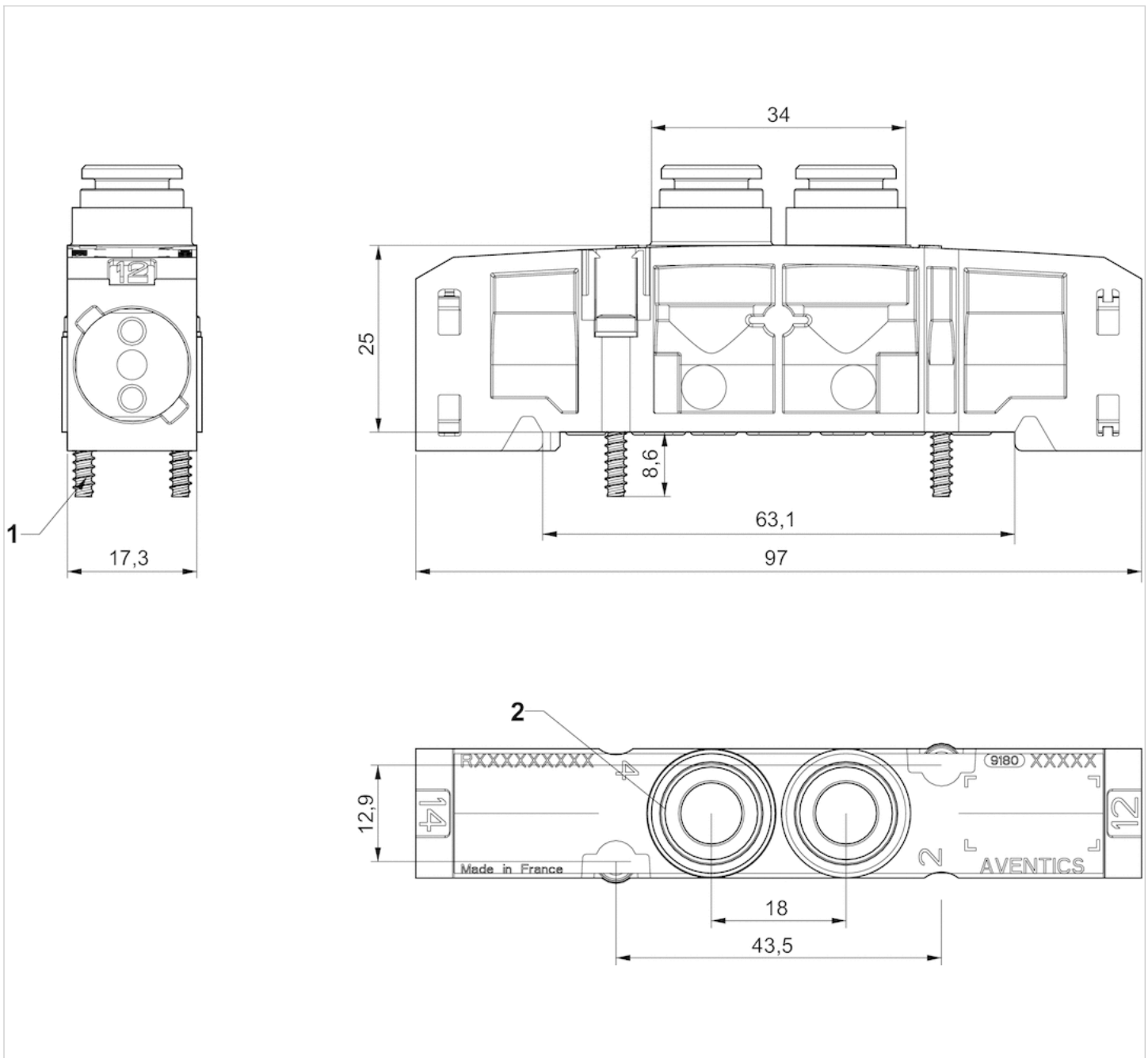

- 1) Screws for plastic Ø3
- 2) Ø 8



# 5/3 directional valve function, ES05

- 5/3
- $Q_n = 0.508 \text{ Cv}$
- closed center
- Compressed air connection output : Base plate
- double solenoid

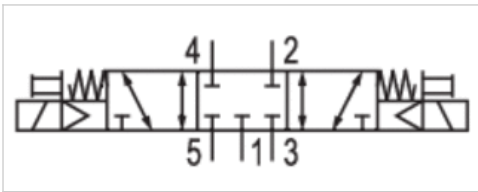

Activation	Electrically
Sealing principle	Soft sealing
Working pressure min./max.	-11 ... 116 psi
Control pressure min./max.	44 ... 116 psi
Ambient temperature min./max.	41 ... 122 °F
Medium temperature min./max.	41 ... 122 °F
Medium	Compressed air
Max. particle size	40 $\mu\text{m}$
Oil content of compressed air	0 ... 5 $\text{mg}/\text{m}^3$
Nominal flow $Q_n$	0.508 Cv
mounting screws	Hexalobular socket (TORX) ISO 10664-10
Mounting screw tightening torque	0.664 ft./lbs.
Tightening torque tolerance	$\pm 0,1 \text{ mT}$
Weight	0.353 lbs

## Technical data

Part No.		Compressed air connection	
		Input	Output
R422003639	closed center	$\varnothing 8$	Base plate
R422P03639	closed center	$\varnothing 8$	Base plate

Part No.	Switch-on time	Switch-off time	Delivery unit
R422003639	20	20	1 piece
R422P03639	20	20	5 piece

Nominal flow  $Q_n$  at 87 psi and  $\Delta p = 14.5 \text{ psi}$

## Technical information

The min. control pressure must be adhered to, since otherwise faulty switching and valve failure may result!  
 The pressure dew point must be at least 27 °F under ambient and medium temperature and may not exceed 5.4 °F .  
 The oil content of compressed air must remain constant during the life cycle.  
 Use only the approved oils from AVENTICS. Further information can be found in the "Technical information" document (available in the MediaCentre).

## Technical information

Material	
Housing	Polyamide Polyoxymethylene
Seals	Acrylonitrile butadiene rubber

## Dimensions

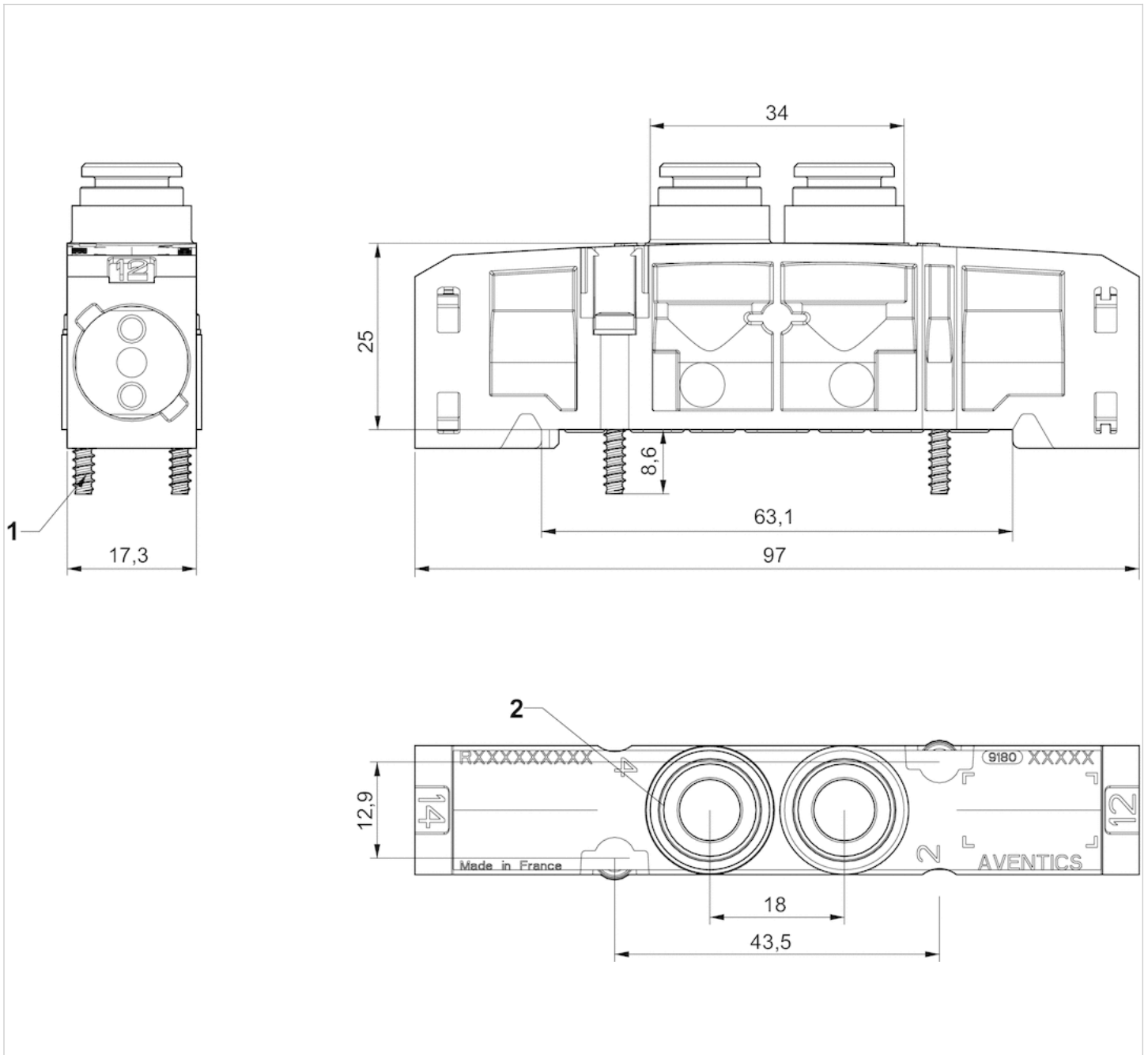





# 2x 3/2 directional valve function, Series ES05 -inch

- 2x3/2
- Qn = 0.376-0.508 Cv
- NC/NC NO/NO
- Compressed air connection output : Ø 3/8
- single solenoid
- With spring return



Activation	Electrically
Working pressure min./max.	-11 ... 116 psi
Control pressure min./max.	44 ... 116 psi
Ambient temperature min./max.	41 ... 122 °F
Medium temperature min./max.	41 ... 122 °F
Medium	Compressed air
Max. particle size	40 µm
Oil content of compressed air	0 ... 5 mg/m <sup>3</sup>
Nominal flow Qn	See table below
mounting screws	Hexalobular socket (TORX) ISO 10664-10
Mounting screw tightening torque	0.664 ft./lbs.
Tightening torque tolerance	±0,1 mT

## Technical data

Part No.			Compressed air connection	
			Input	Output
R422103171		NC/NC	Base plate	Ø 3/8
R422P03171		NC/NC	Base plate	Ø 3/8
R422103172		NO/NO	Base plate	Ø 3/8
R422P03172		NO/NO	Base plate	Ø 3/8

Part No.	Nominal flow Qn	Switch-on time	Switch-off time	Delivery unit
R422103171	0.376 Cv	20	20	1 piece
R422P03171	0.376 Cv	20	20	5 piece
R422103172	0.508 Cv	20	20	1 piece
R422P03172	0.508 Cv	20	20	5 piece

Nominal flow Qn at 87 psi and  $\Delta p = 14.5$  psi

## Technical information

The min. control pressure must be adhered to, since otherwise faulty switching and valve failure may result!

The pressure dew point must be at least 27 °F under ambient and medium temperature and may not exceed 5.4 °F .

The oil content of compressed air must remain constant during the life cycle.

Use only the approved oils from AVENTICS. Further information can be found in the "Technical information" document (available in the MediaCentre).

## Technical information

Material	
Housing	Polyamide Polyoxymethylene
Seals	Acrylonitrile butadiene rubber

## Dimensions

### Dimensions

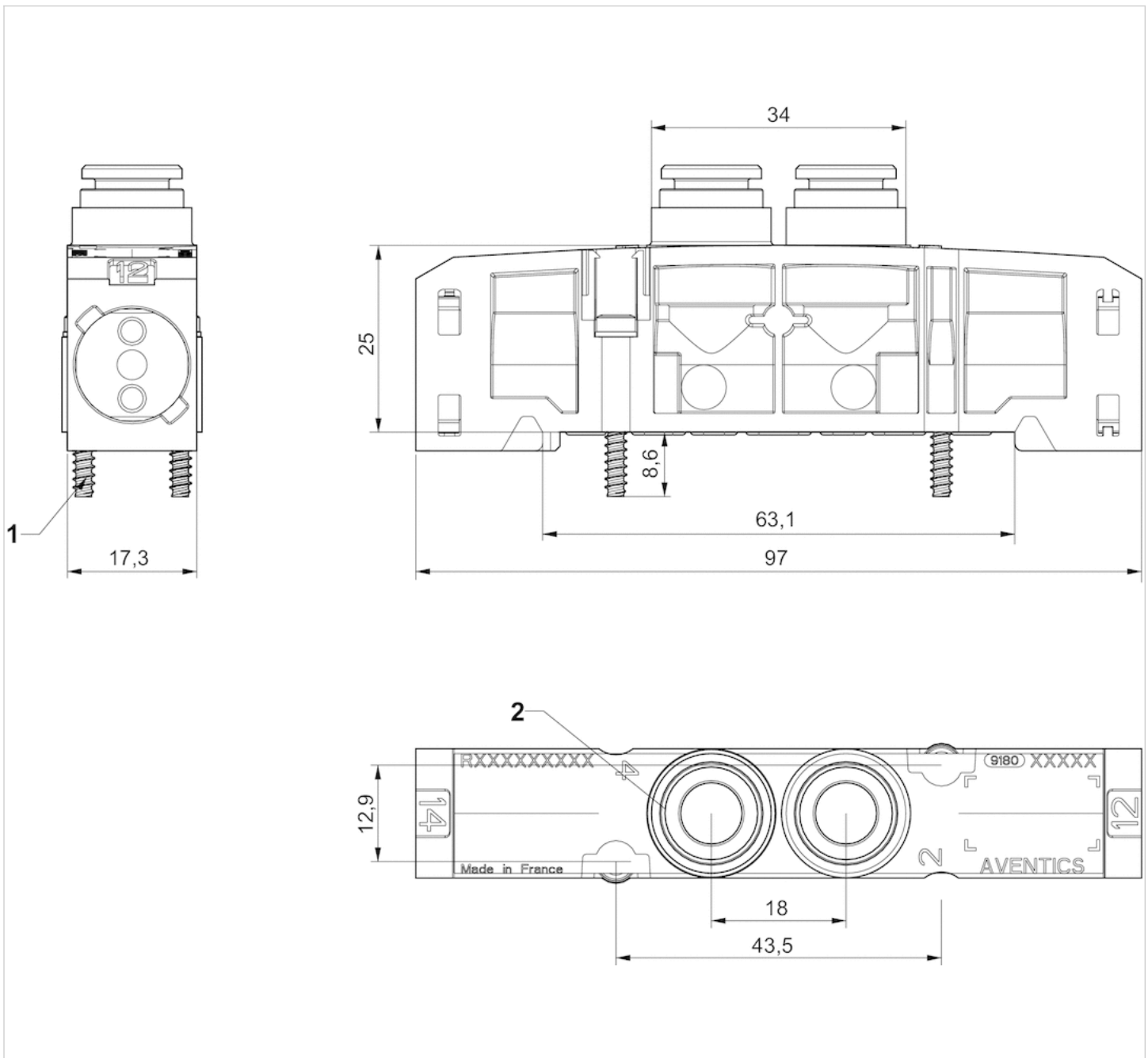

- 1) Screws for plastic Ø3
- 2) 3/8"





# 5/2 directional valve function, Series ES05 -inch

- 5/2
- $Q_n = 0.62 \text{ Cv}$
- Compressed air connection output :  $\text{Ø } 3/8$
- single solenoid double solenoid
- With spring return



Activation	Electrically
Working pressure min./max.	-11 ... 116 psi
Control pressure min./max.	44 ... 116 psi
Ambient temperature min./max.	41 ... 122 °F
Medium temperature min./max.	41 ... 122 °F
Medium	Compressed air
Max. particle size	40 $\mu\text{m}$
Oil content of compressed air	0 ... 5 $\text{mg/m}^3$
Nominal flow $Q_n$	0.62 Cv
mounting screws	Hexalobular socket (TORX) ISO 10664-10
Mounting screw tightening torque	0.664 ft./lbs.
Tightening torque tolerance	$\pm 0,1 \text{ mT}$

## Technical data

Part No.		Compressed air connection		Switch-on time
		Input	Output	
R422103169		Base plate	$\text{Ø } 3/8$	20
R422P03169		Base plate	$\text{Ø } 3/8$	20
R422103170		Base plate	$\text{Ø } 3/8$	20
R422P03170		Base plate	$\text{Ø } 3/8$	20

Part No.	Switch-off time	Delivery unit
R422103169	35	1 piece
R422P03169	35	5 piece
R422103170	20	1 piece
R422P03170	20	5 piece

Nominal flow  $Q_n$  at 87 psi and  $\Delta p = 14.5 \text{ psi}$

## Technical information

The min. control pressure must be adhered to, since otherwise faulty switching and valve failure may result!

The pressure dew point must be at least 27 °F under ambient and medium temperature and may not exceed 5.4 °F .

The oil content of compressed air must remain constant during the life cycle.

Use only the approved oils from AVENTICS. Further information can be found in the "Technical information" document (available in the MediaCentre).

## Technical information

Material	
Housing	Polyamide Polyoxymethylene
Seals	Acrylonitrile butadiene rubber

## Dimensions

### Dimensions

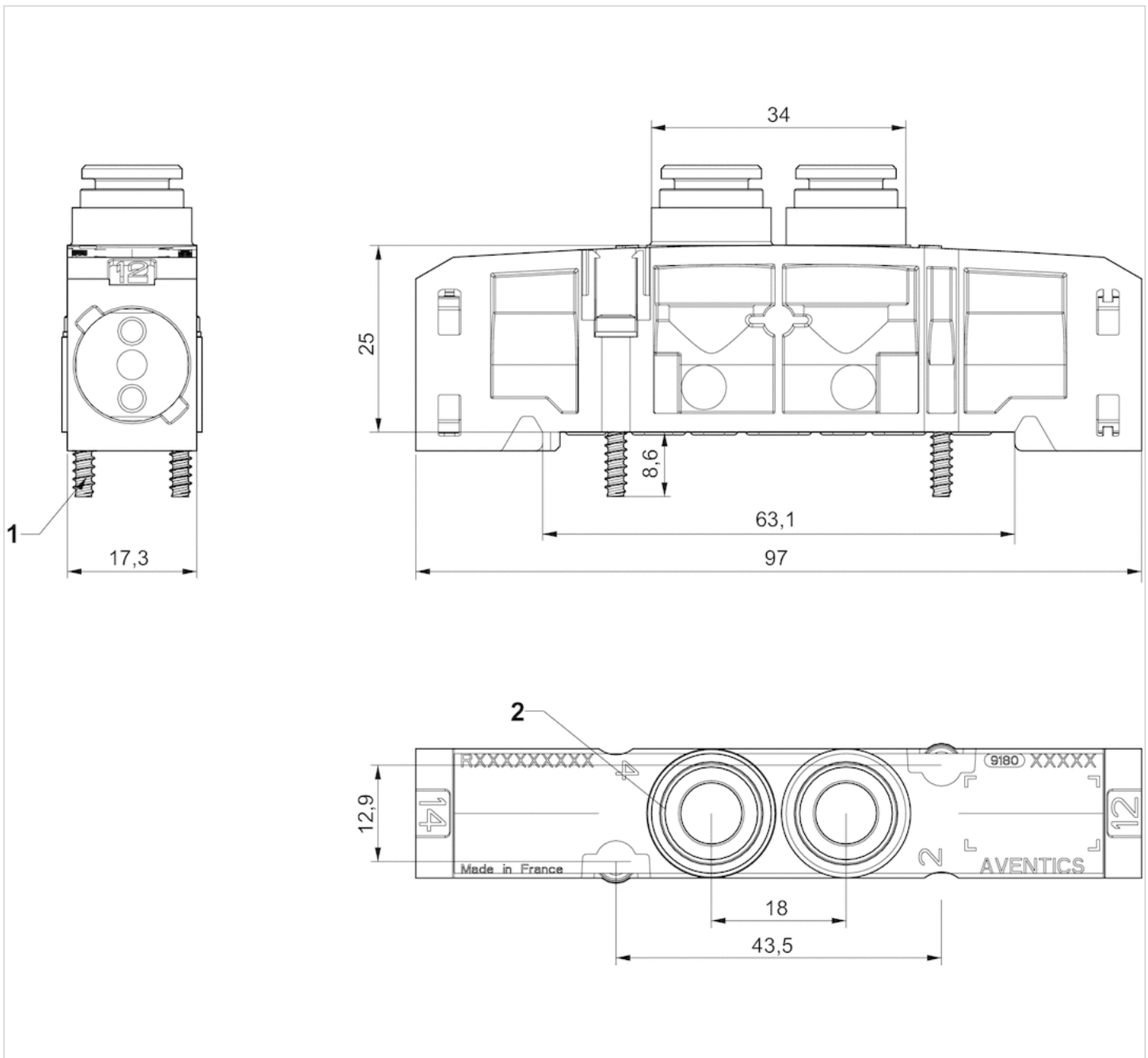

- 1) Screws for plastic Ø3
- 2) 3/8"

# 5/3 directional valve function, ES05 - inch

- $Q_n = 0.508 \text{ Cv}$
- closed center
- Compressed air connection output : Base plate
- double solenoid

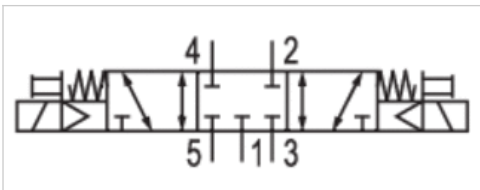

Activation	Electrically
Sealing principle	Soft sealing
Working pressure min./max.	-11 ... 116 psi
Control pressure min./max.	44 ... 116 psi
Ambient temperature min./max.	41 ... 122 °F
Medium temperature min./max.	41 ... 122 °F
Medium	Compressed air
Max. particle size	40 $\mu\text{m}$
Oil content of compressed air	0 ... 5 $\text{mg/m}^3$
Nominal flow $Q_n$	0.508 Cv
mounting screws	Hexalobular socket (TORX) ISO 10664-10
Mounting screw tightening torque	0.664 ft./lbs.
Tightening torque tolerance	$\pm 0,1 \text{ mT}$
Weight	0.353 lbs

## Technical data

Part No.		Compressed air connection	
		Input	Output
R422003640	closed center	$\varnothing 3/8$	Base plate
R422P03640	closed center	$\varnothing 3/8$	Base plate

Part No.	Switch-on time	Switch-off time	Delivery unit
R422003640	20	20	1 piece
R422P03640	20	20	5 piece

Nominal flow  $Q_n$  at 87 psi and  $\Delta p = 14.5 \text{ psi}$

## Technical information

The min. control pressure must be adhered to, since otherwise faulty switching and valve failure may result!  
 The pressure dew point must be at least 27 °F under ambient and medium temperature and may not exceed 5.4 °F .  
 The oil content of compressed air must remain constant during the life cycle.  
 Use only the approved oils from AVENTICS. Further information can be found in the "Technical information" document (available in the MediaCentre).

## Technical information

Material	
Housing	Polyamide Polyoxymethylene
Seals	Acrylonitrile butadiene rubber

## Dimensions

### Dimensions

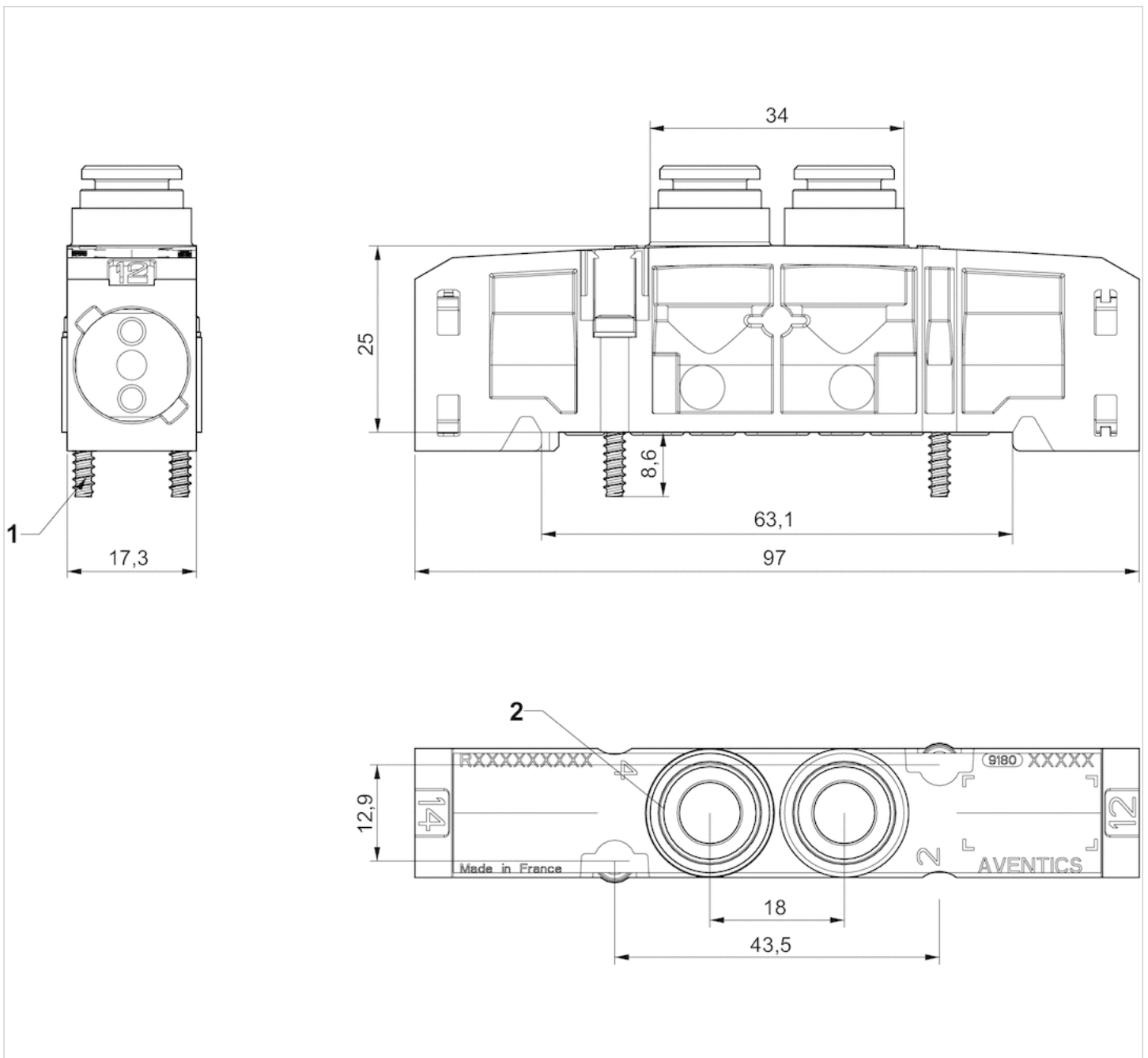

- 1) Screws for plastic Ø3
- 2) Ø 3/8"



# End plate kit for single wiring

- for ES05



Working pressure min./max.	0 ... 116 psi
Ambient temperature min./max.	41 ... 122 °F
Medium temperature min./max.	41 ... 122 °F
Mounting screw	Hexalobular socket (TORX) ISO 10664-10
Tightening torque for mounting screws	0.664 ft./lbs.

## Technical data

Part No.	Compressed air connection Input [1]	Compressed air connection Exhaust [3 / 5]	Pilot control exhaust
R422003340	G 3/8	G 3/8	G 1/8
R422P03340	G 3/8	G 3/8	G 1/8

Part No.	Delivery unit
R422003340	1 piece
R422P03340	5 piece

Scope of delivery: 1 left end plate, 1 right end plate, 2 initial tie rods, 4 tie rod screws, 1 seal, and 2 blanking plugs G1/8

## Technical information

The min. control pressure must be adhered to, since otherwise faulty switching and valve failure may result!  
 The pressure dew point must be at least 27 °F under ambient and medium temperature and may not exceed 5.4 °F .  
 The oil content of compressed air must remain constant during the life cycle.  
 Use only the approved oils from AVENTICS. Further information can be found in the "Technical information" document (available in the MediaCentre).

Only use fittings with cylindrical threads (BSPP).

## Technical information

Material	
Screws	Stainless steel

## Dimensions

### Dimensions, Left end plate, Port 1, X

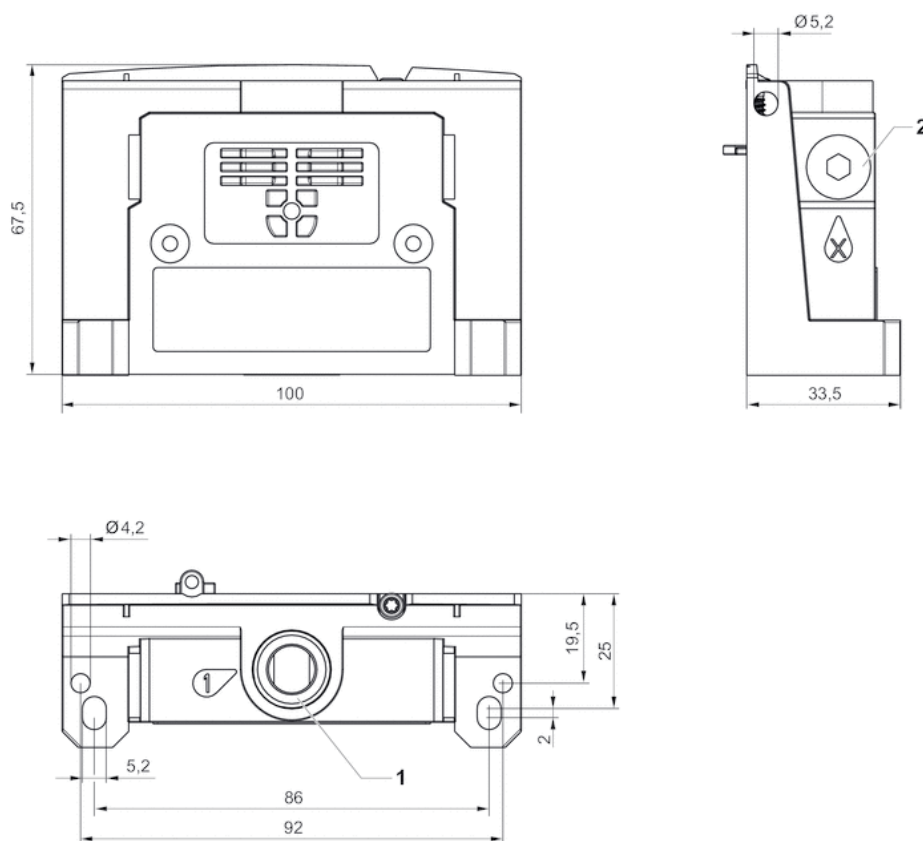

1) Port 1 G 3/8"

2) 2 connections X G 1/8"

Dimensions, Right end plate, Port 3, 5, R

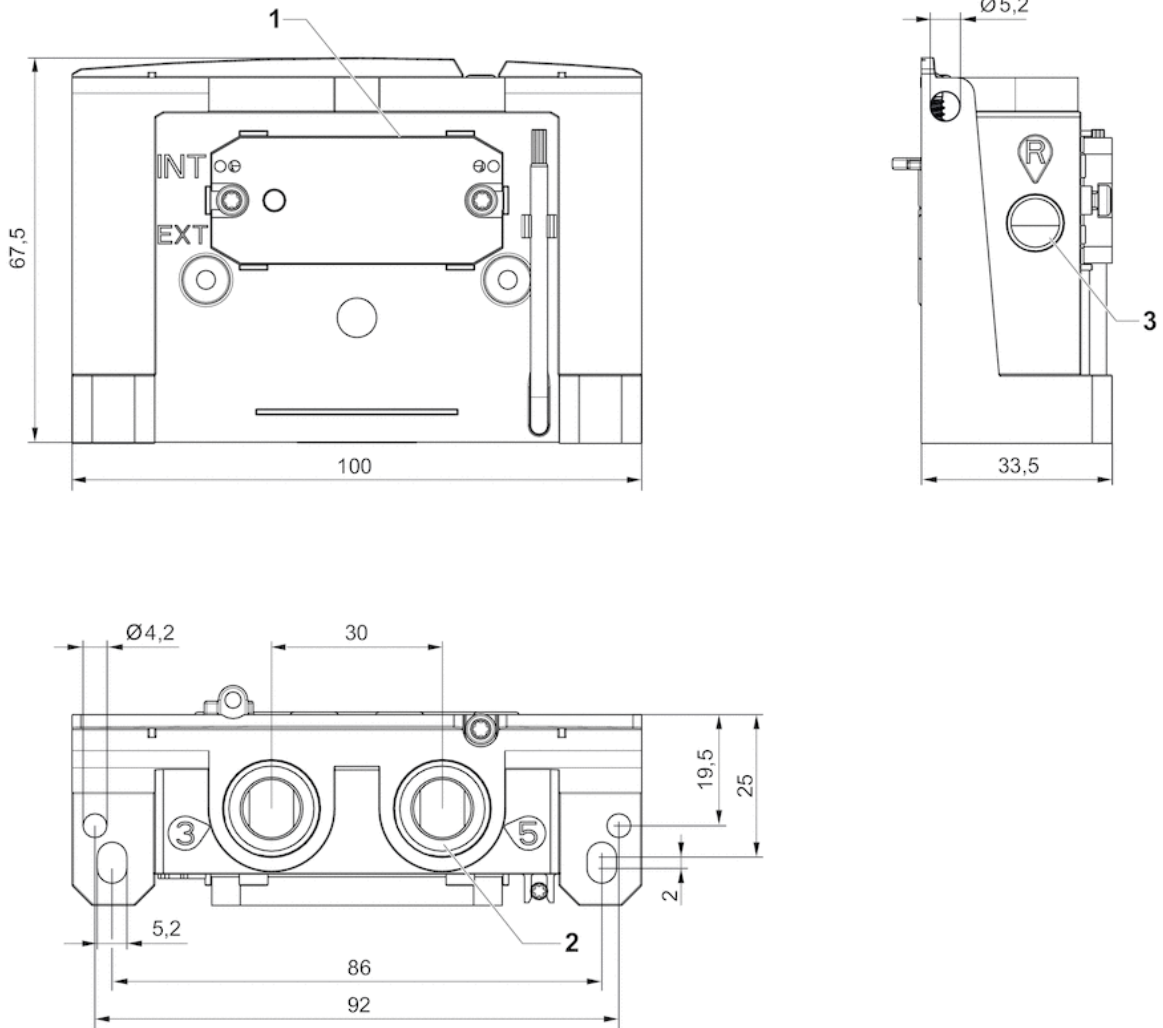

- 1) Plate for internal or external pilot
- 2) Port 3, 5 G 3/8"
- 3) 2 connections R G1/8"

# End plate kit for D-Sub

- D-Sub plug, 25-pin, on the side

- for ES05



Type	Multipole
Working pressure min./max.	0 ... 116 psi
Ambient temperature min./max.	41 ... 122 °F
Medium temperature min./max.	41 ... 122 °F
electr. connection	D-Sub plug, 25-pin, on the side
Protection class	IP50
Mounting screw	Hexalobular socket (TORX) ISO 10664-10
Tightening torque for mounting screws	0.664 ft./lbs.

## Technical data

Part No.	Type	Compressed air connection Input [1]	Compressed air connection Exhaust [3 / 5]
R422003346	type A	G 3/8	G 3/8
R422P03346	type A	G 3/8	G 3/8
R422003355	type B	G 3/8	G 3/8
R422P03355	type B	G 3/8	G 3/8

Part No.	Pilot control exhaust	Pilot connection	Delivery unit
R422003346	G 1/8	G 1/8	1 piece
R422P03346	G 1/8	G 1/8	5 piece
R422003355	G 1/8	G 1/8	1 piece
R422P03355	G 1/8	G 1/8	5 piece

Scope of delivery: 1 left end plate, 1 right end plate, 2 initial tie rods, 4 tie rod screws, 1 seal, and 2 blanking plugs G1/8

## Technical information

The min. control pressure must be adhered to, since otherwise faulty switching and valve failure may result!

The pressure dew point must be at least 27 °F under ambient and medium temperature and may not exceed 5.4 °F .

The oil content of compressed air must remain constant during the life cycle.

Use only the approved oils from AVENTICS. Further information can be found in the "Technical information" document (available in the MediaCentre).

Only use fittings with cylindrical threads (BSPP).

## Technical information

### Material

Housing	Polyamide Polyoxymethylene
Screws	Stainless steel

## Dimensions

### Dimensions, Left end plate, Port 1, X

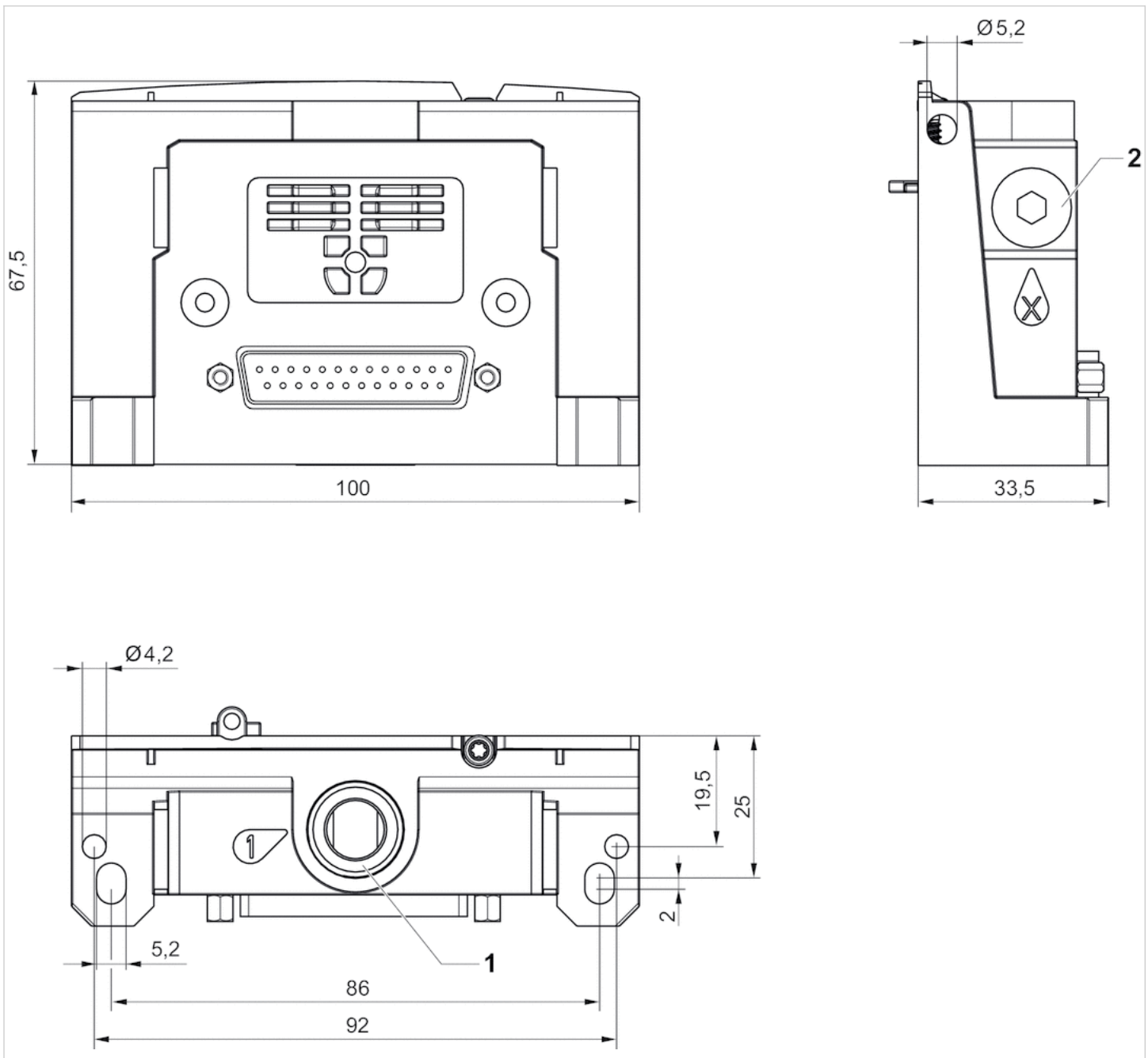

1) Port 1 G 3/8"

2) 2 connections X G 1/8"

Dimensions, Right end plate, Port 3, 5, R

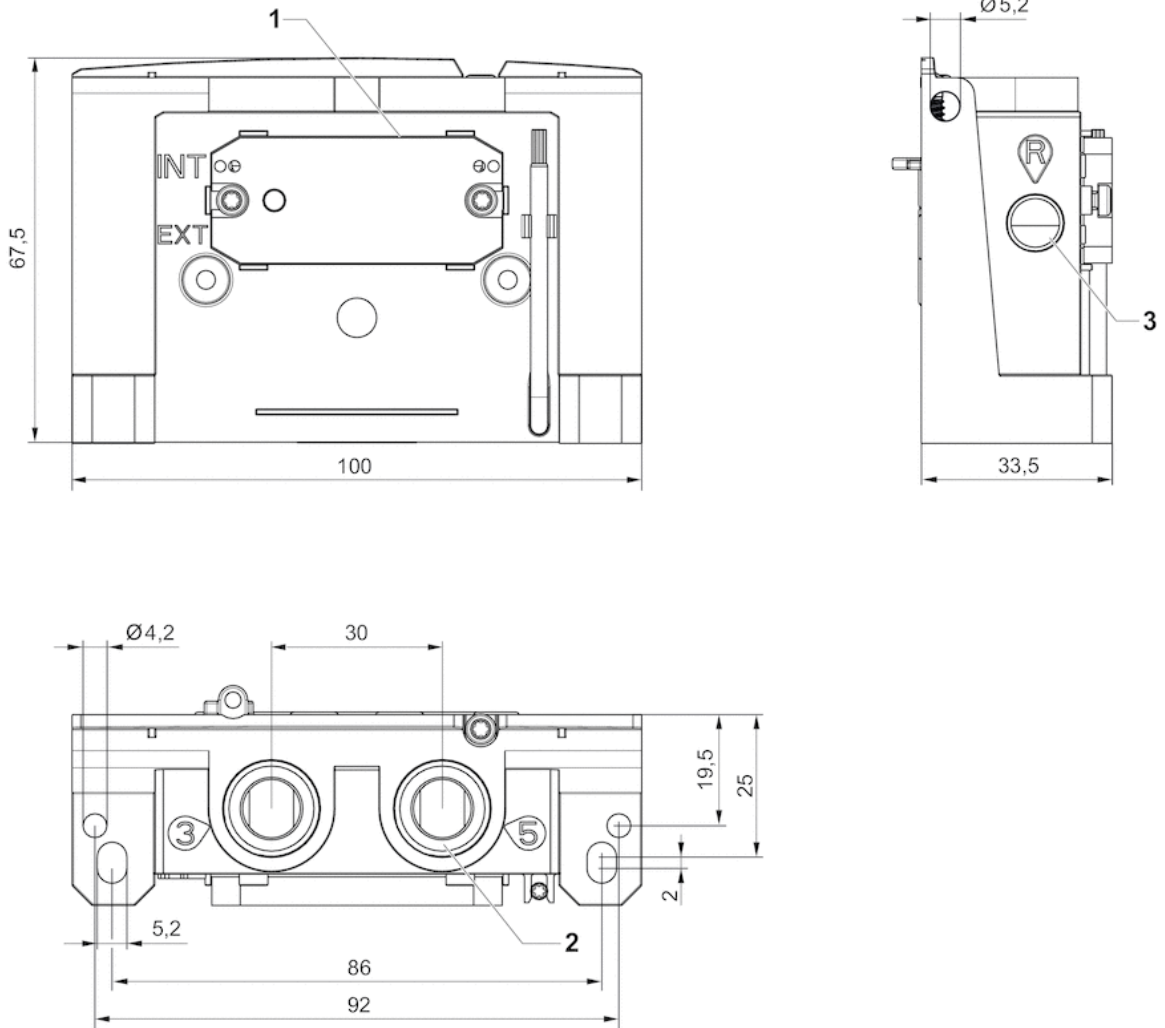

- 1) Plate for internal or external pilot
- 2) Port 3, 5 G 3/8"
- 3) 2 connections R G1/8"

## Pin assignments

PIN assignment and cable colors, cable identification as per DIN 47100

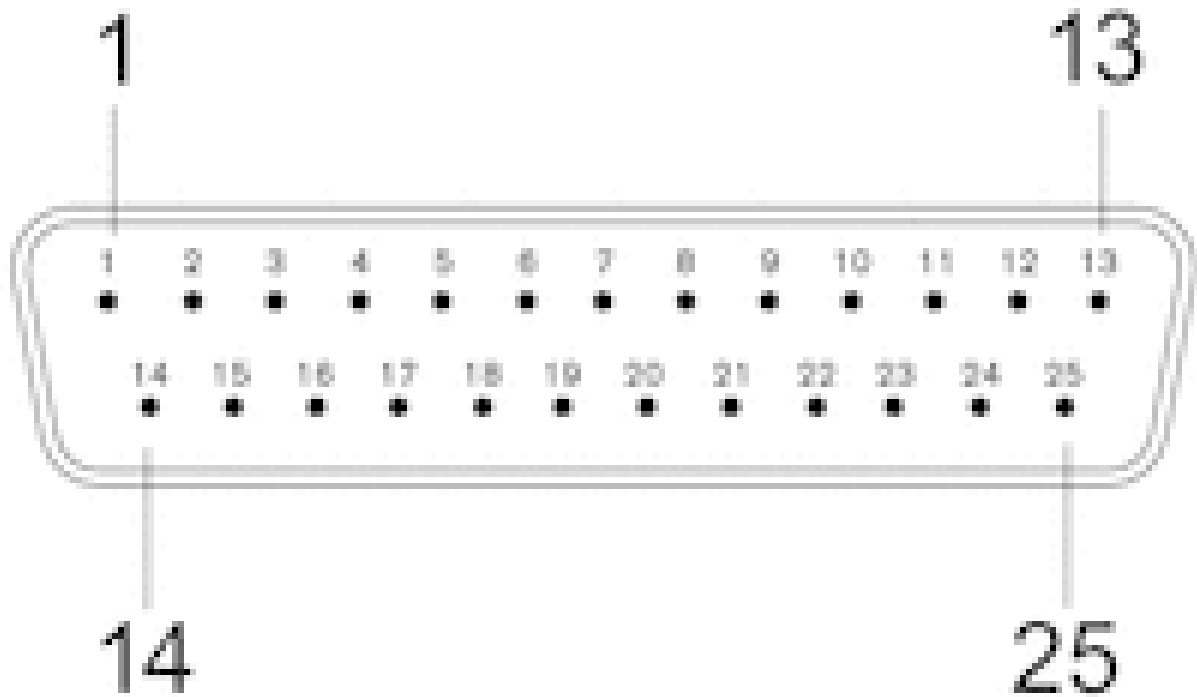

Plug

Valve position	1	2	3	4	5	6	7	8	9
Pin	1 / 2	3 / 4	5 / 6	7 / 8	9 / 10	11 / 12	13 / 14	15 / 16	17 / 18
Coil	14 / 12	14 / 12	14 / 12	14 / 12	14 / 12	14 / 12	14 / 12	14 / 12	14 / 12

10	11	12	
19 / 20	21 / 22	23 / 24	25
14 / 12	14 / 12	14 / 12	0 V DC

Valve position	1	2	3	4	5	6	7	8	9
Pin	1 / 14	2 / 15	3 / 16	4 / 17	5 / 18	6 / 19	7 / 20	8 / 21	9 / 22
Coil	14 / 12	14 / 12	14 / 12	14 / 12	14 / 12	14 / 12	14 / 12	14 / 12	14 / 12
10	11		12						
10 / 23	11 / 24		12 / 25			13			
14 / 12	14 / 12		14 / 12			0 V DC			



# Base plate, Series ES05

- Base plate 2x for single wiring
- Valve plug connector form C industry
- for ES05



Working pressure min./max.	0 ... 116 psi
Control pressure min./max.	44 ... 116 psi
Ambient temperature min./max.	41 ... 122 °F
Medium temperature min./max.	41 ... 122 °F
Medium	Compressed air
Max. particle size	40 µm
Oil content of compressed air	0 ... 25 mg/m <sup>3</sup>
electr. connection	Valve plug connector form C industry
Tightening torque for mounting screws	0.664 ft./lbs.

## Technical data

Part No.	Type	Scope of delivery	Delivery unit	Fig.
R422003358	single solenoid	2 base plates, incl. 1 seal	1 piece	Fig. 1
R422P03358	single solenoid	2 base plates, incl. 1 seal	5 piece	Fig. 1
R422003341	double solenoid	2 base plates, incl. 1 seal	1 piece	Fig. 2
R422P03341	double solenoid	2 base plates, incl. 1 seal	5 piece	Fig. 2

## Technical information

The min. control pressure must be adhered to, since otherwise faulty switching and valve failure may result!

The pressure dew point must be at least 27 °F under ambient and medium temperature and may not exceed 5.4 °F .

The oil content of compressed air must remain constant during the life cycle.

Use only the approved oils from AVENTICS. Further information can be found in the "Technical information" document (available in the MediaCentre).

## Technical information

Material	
Housing	Polyamide fiber-glass reinforced
Seal	Nitrile butadiene rubber

# Dimensions

Dimensions, Fig. 1

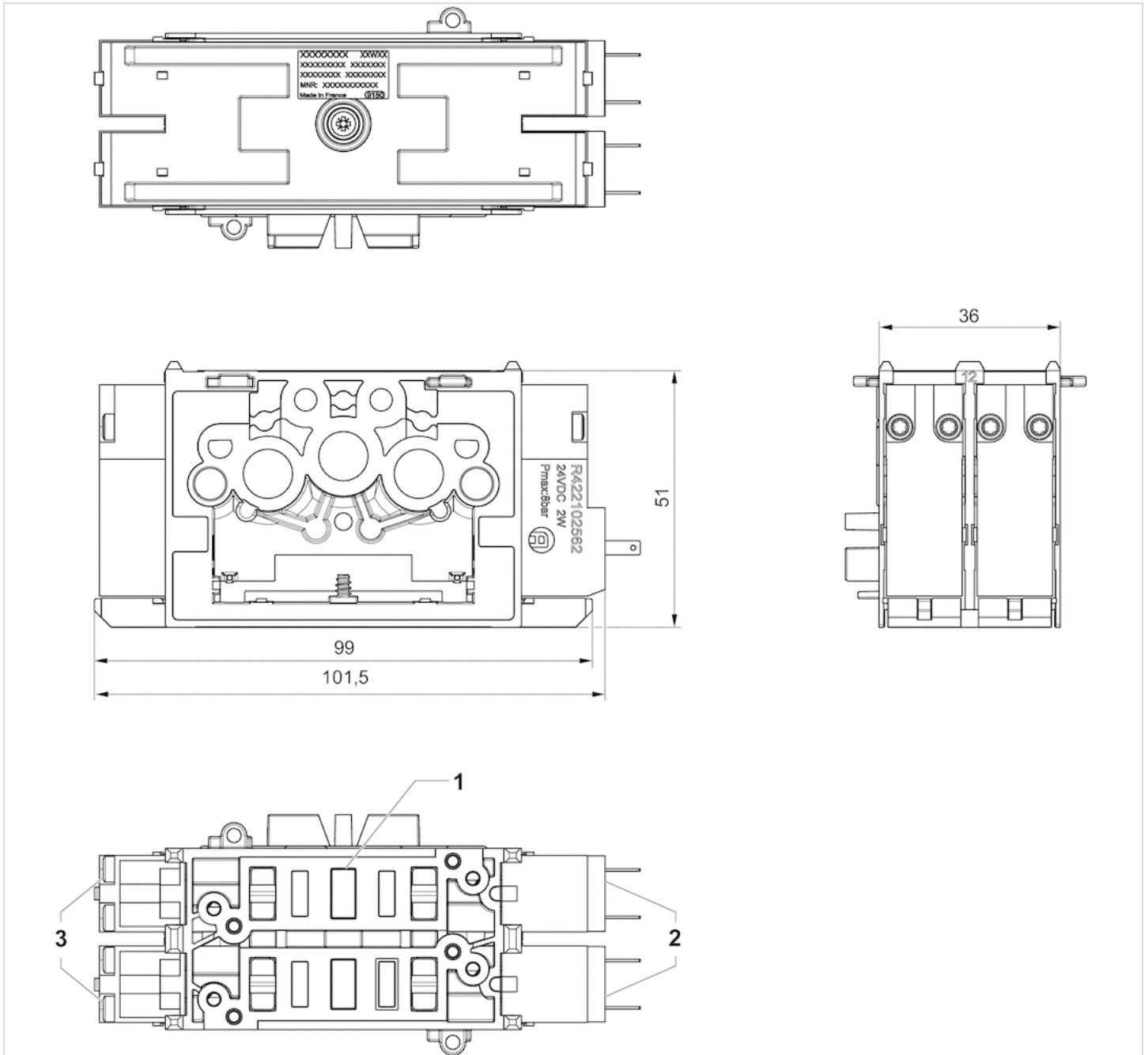

- 1) 2 pilot valves with external electrical connection
- 2) Place for 2 valves
- 3) Pilot blanking plate

Dimensions, Fig. 2

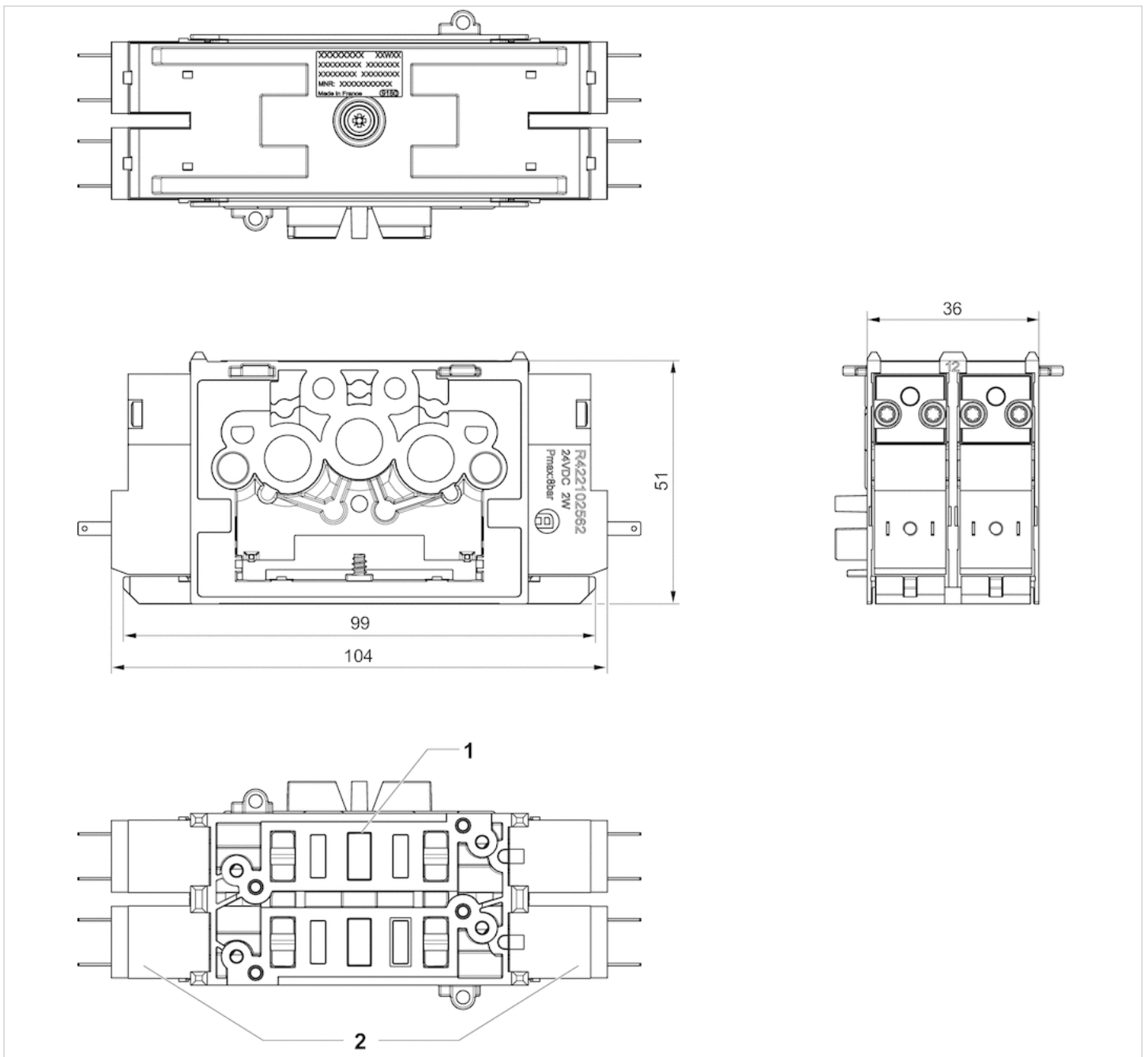

- 1) 4 pilot valves with external electrical connection
- 2) Place for 2 valves

# Base plate, Series ES05

- Base plate 2x for single wiring
- M8x1 (3-pin)
- for ES05



Working pressure min./max.	0 ... 116 psi
Control pressure min./max.	44 ... 116 psi
Ambient temperature min./max.	41 ... 122 °F
Medium temperature min./max.	41 ... 122 °F
Medium	Compressed air
Max. particle size	40 µm
Oil content of compressed air	0 ... 25 mg/m³
electr. connection	M8x1 (3-pin)
Tightening torque for mounting screws	0.664 ft./lbs.

## Technical data

Part No.	Type	Scope of delivery	Delivery unit	Fig.
R422103848	single solenoid	Base plate 2x, incl. 1 seal	1 piece	Fig. 1
R422P03848	single solenoid	Base plate 2x, incl. 1 seal	5 piece	Fig. 1
R422103849	double solenoid	Base plate 2x, incl. 1 seal	1 piece	Fig. 2
R422P03849	double solenoid	Base plate 2x, incl. 1 seal	5 piece	Fig. 2

## Technical information

The min. control pressure must be adhered to, since otherwise faulty switching and valve failure may result!  
 The pressure dew point must be at least 27 °F under ambient and medium temperature and may not exceed 5.4 °F .  
 The oil content of compressed air must remain constant during the life cycle.  
 Use only the approved oils from AVENTICS. Further information can be found in the "Technical information" document (available in the MediaCentre).

## Technical information

Material	
Housing	Polyamide fiber-glass reinforced
Seal	Nitrile butadiene rubber

## Dimensions

Dimensions, Fig. 1

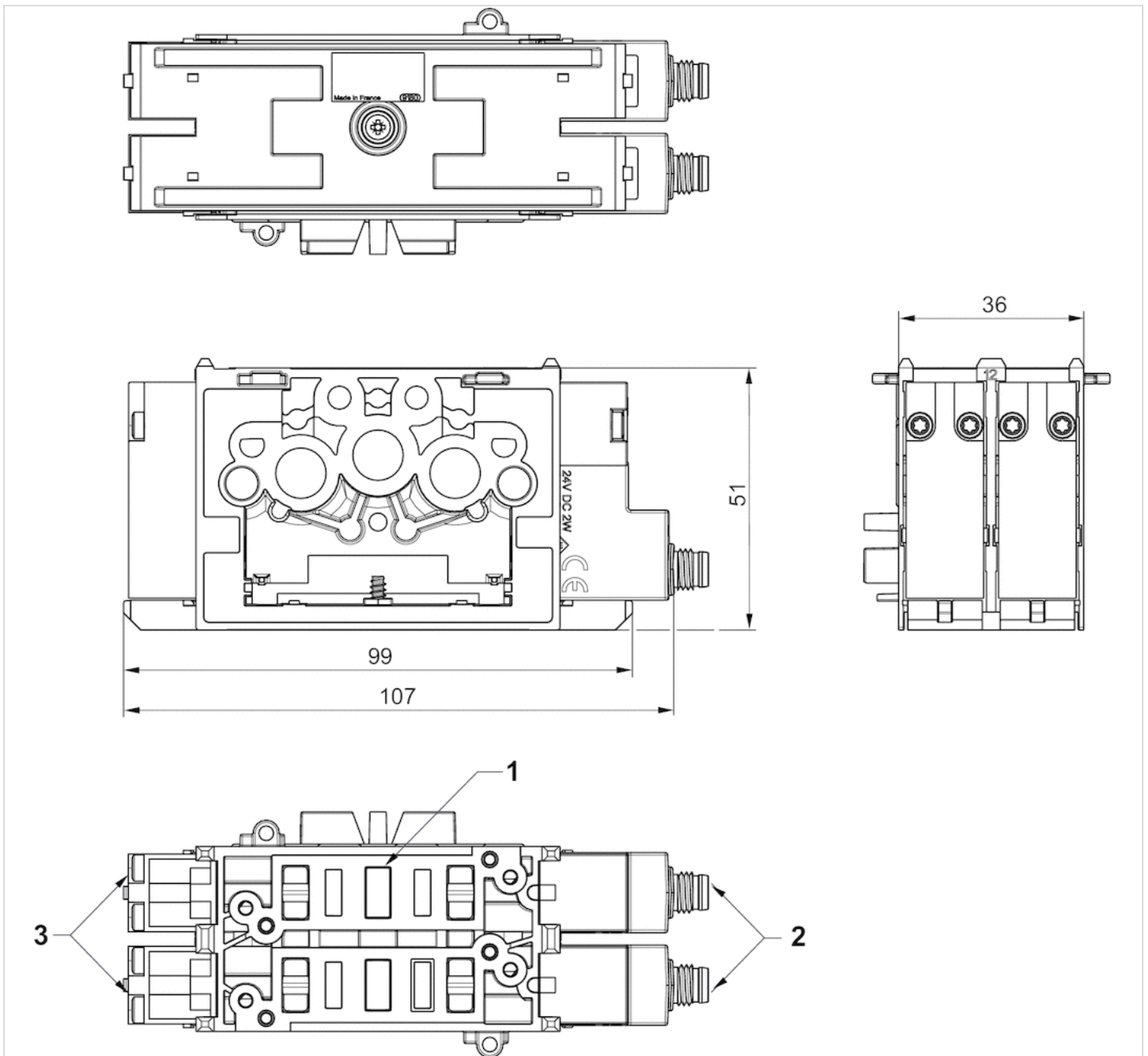

- 1) Place for 2 valves
  - 2) 2 pilot valves M8x1
  - 3) Pilot blanking plate
- Only for single solenoid 5/2 direction valve function

Dimensions, Fig. 2

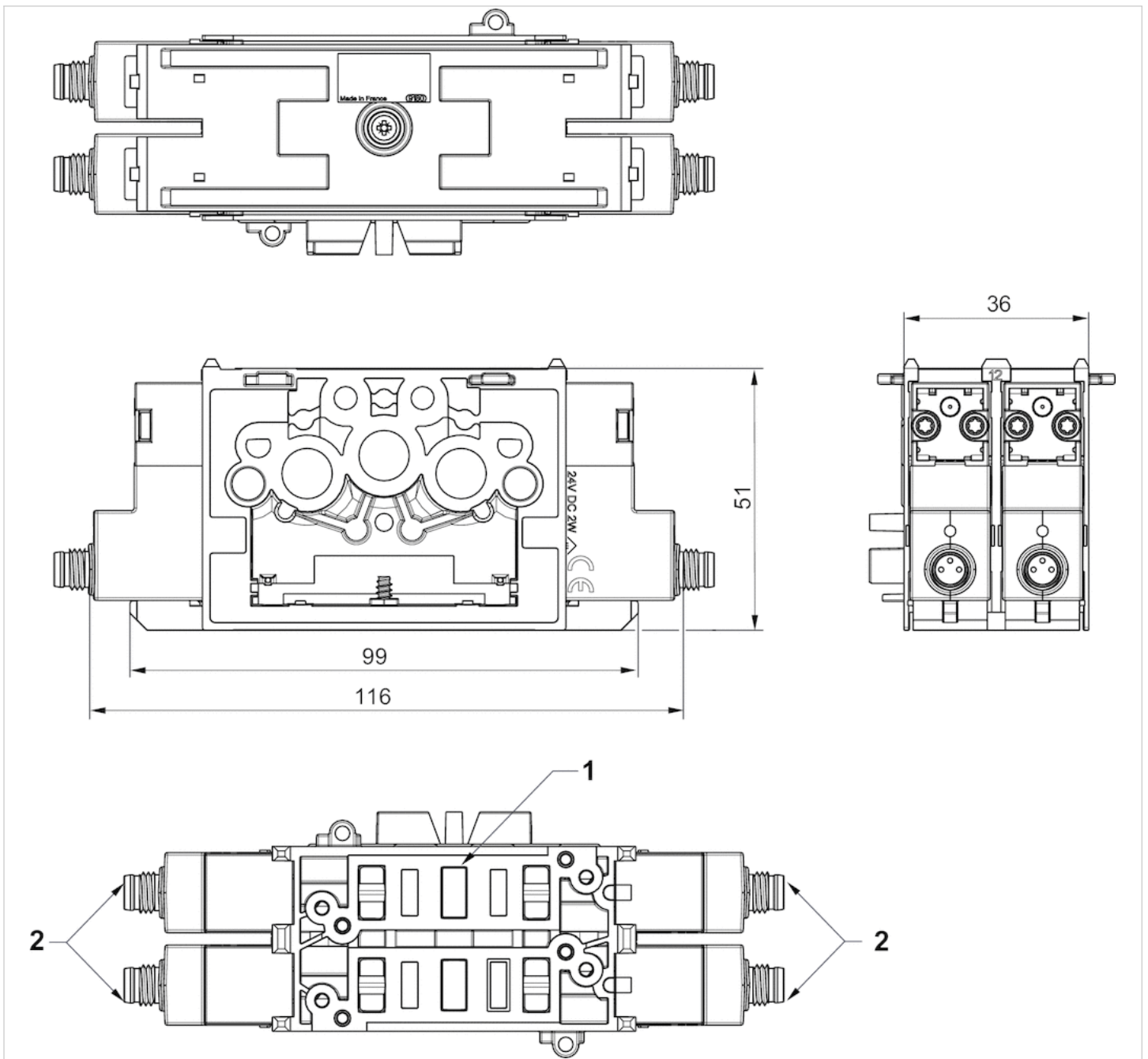

- 1) Place for 2 valves
- 2) 4 pilot valves M8x1

## Pin assignments

### PIN assignment for valve plug connectors

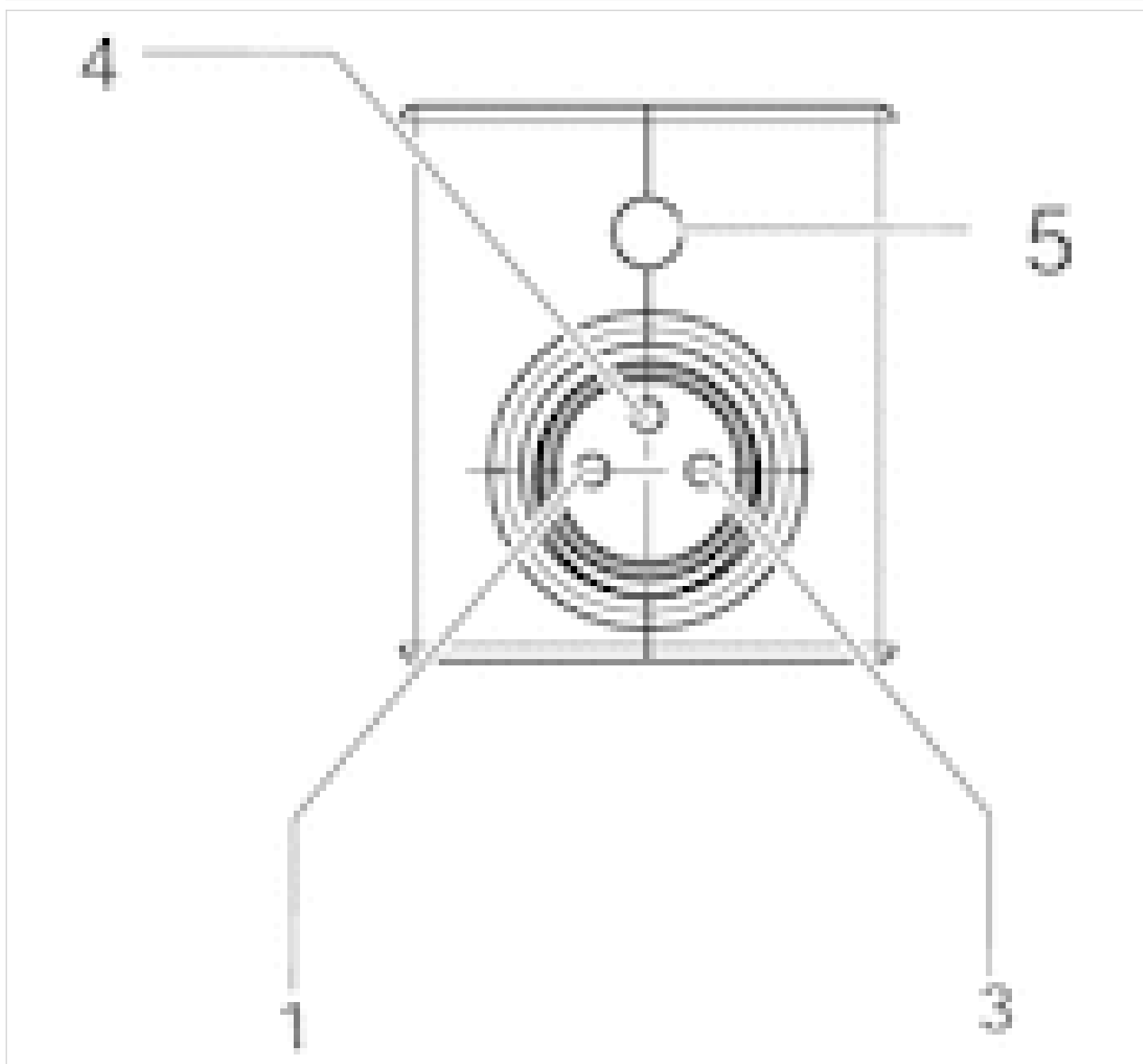

Pin assignment:

- 1) Pin not assigned
- 3) 0 V
- 4) 24 V
- 5) LED

Note: Bi-polar protective circuit to prevent overvoltage

# Base plate, Series ES05

- Base plate 2x for internal electrical control
- for ES05



Working pressure min./max.	0 ... 116 psi
Control pressure min./max.	44 ... 116 psi
Ambient temperature min./max.	41 ... 122 °F
Medium temperature min./max.	41 ... 122 °F
Medium	Compressed air
Max. particle size	40 µm
Oil content of compressed air	0 ... 25 mg/m <sup>3</sup>
Tightening torque for mounting screws	0.664 ft./lbs.

## Technical data

Part No.	Type	Scope of delivery	Type of contact	Delivery unit
R422102671	single solenoid	Base plate 2x, incl. 1 seal	PNP	1 piece
R422P02671	single solenoid	Base plate 2x, incl. 1 seal	PNP	5 piece
R422102621	double solenoid	Base plate 2x, incl. 1 seal	PNP	1 piece
R422P02621	double solenoid	Base plate 2x, incl. 1 seal	PNP	5 piece
R422102853	single solenoid	Base plate 2x, incl. 1 seal	NPN	1 piece
R422102854	double solenoid	Base plate 2x, incl. 1 seal	NPN	1 piece

Part No.	Fig.
R422102671	Fig. 1
R422P02671	Fig. 1
R422102621	Fig. 2
R422P02621	Fig. 2
R422102853	Fig. 1
R422102854	Fig. 2

PNP: GND = 0 V DC, NPN: GND = 24 V DC

## Technical information

The min. control pressure must be adhered to, since otherwise faulty switching and valve failure may result!

The pressure dew point must be at least 27 °F under ambient and medium temperature and may not exceed 5.4 °F .

The oil content of compressed air must remain constant during the life cycle.

Use only the approved oils from AVENTICS. Further information can be found in the "Technical information" document (available in the MediaCentre).

For use in conjunction with end plate kit with D-Sub



## Technical information

### Material

Housing	Polyamide fiber-glass reinforced
Seal	Nitrile butadiene rubber

## Dimensions

### Dimensions, Fig. 1

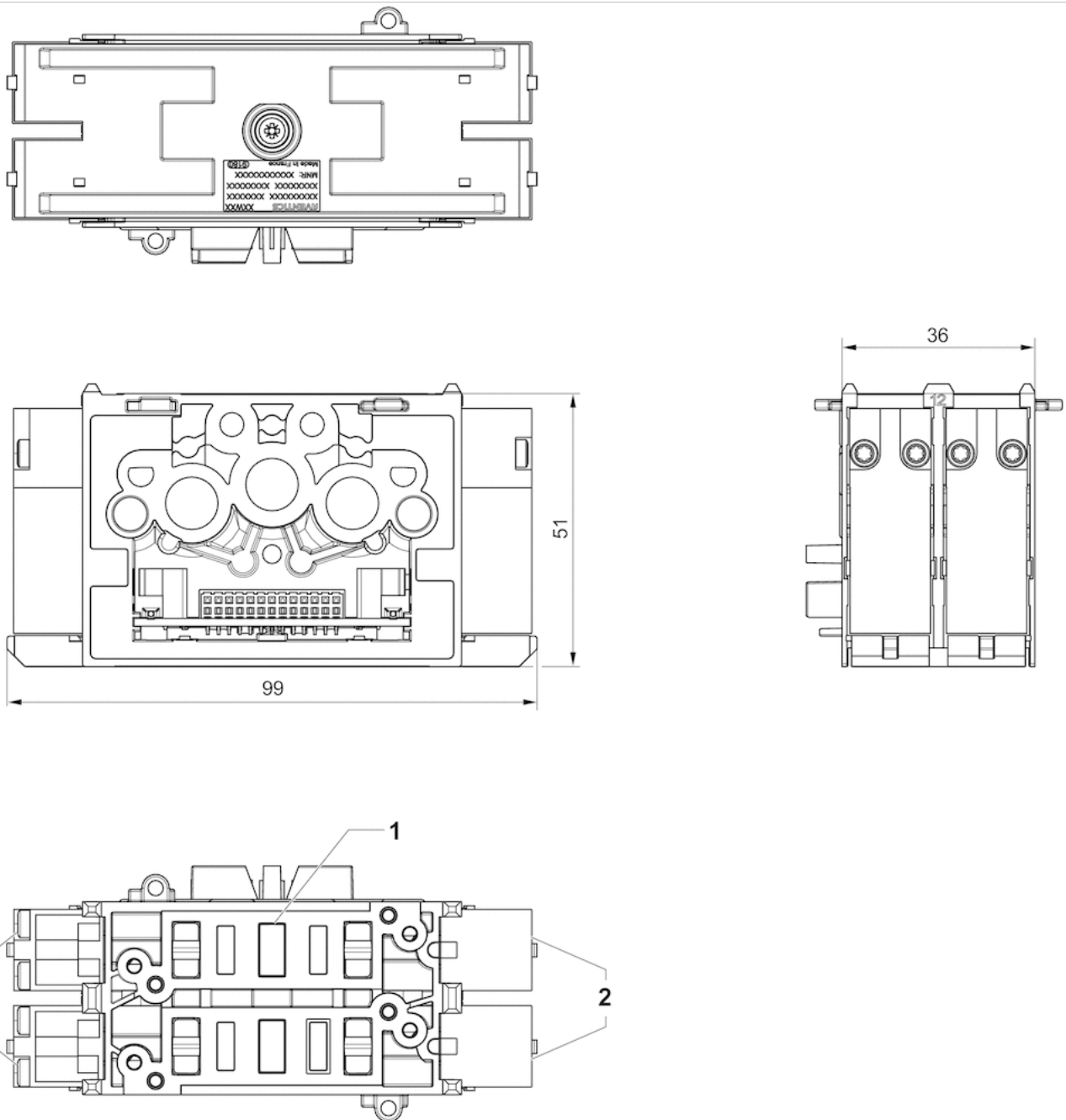

- 1) Place for 2 valves
  - 2) 2 pilot valves
  - 3) Pilot blanking plate
- Only for single solenoid 5/2 direction valve function



# Supply plate

- input [1] Ø 12
- for ES05



Working pressure min./max.	0 ... 116 psi
Ambient temperature min./max.	41 ... 122 °F
Medium temperature min./max.	41 ... 122 °F
Medium	Compressed air
Mounting screw	Hexalobular socket (TORX) ISO 10664-10
Tightening torque for mounting screws	0.664 ft./lbs.

## Technical data

Part No.	Compressed air connection Input [1]	Delivery unit
R422102622	Ø 12	1 piece
R422P02622	Ø 12	5 piece

Delivery includes sealing kit and 2x mounting screw

## Technical information

The pressure dew point must be at least 27 °F under ambient and medium temperature and may not exceed 5.4 °F .  
 The oil content of compressed air must remain constant during the life cycle.  
 Use only the approved oils from AVENTICS. Further information can be found in the "Technical information" document (available in the MediaCentre).

## Technical information

Material	
Housing	Aluminum
Screws	Steel

## Dimensions

### Dimensions

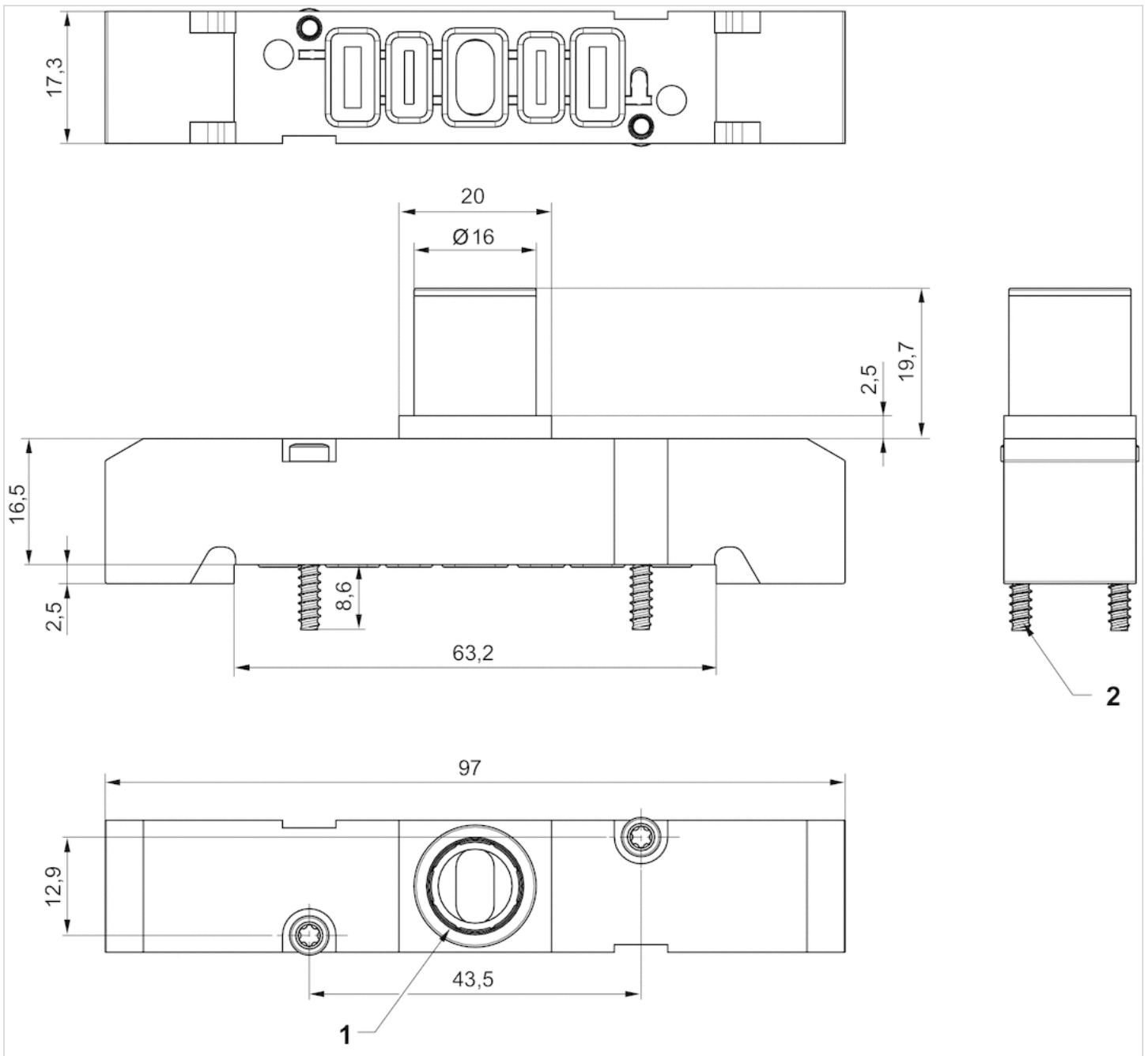

1) input [1]  $\text{Ø}12$

2) Screws for plastic  $\text{Ø}3$

# Supply plate

- input [1] Ø 12, Output [3/5]: Ø8

- for ES05



Working pressure min./max.	0 ... 116 psi
Ambient temperature min./max.	41 ... 122 °F
Medium temperature min./max.	41 ... 122 °F
Medium	Compressed air
Mounting screw	Hexalobular socket (TORX) ISO 10664-10
Tightening torque for mounting screws	0.664 ft./lbs.

## Technical data

Part No.	Compressed air connection Input [1]	Compressed air connection Exhaust [3 / 5]	Delivery unit
R422102809	Ø 12	Ø 8	1 piece
R422P02809	Ø 12	Ø 8	5 piece

Delivery includes sealing kit and 2x mounting screw

## Technical information

The pressure dew point must be at least 27 °F under ambient and medium temperature and may not exceed 5.4 °F .

The oil content of compressed air must remain constant during the life cycle.

Use only the approved oils from AVENTICS. Further information can be found in the "Technical information" document (available in the MediaCentre).

## Technical information

Material	
Housing	Aluminum
Screws	Steel

## Dimensions

### Dimensions

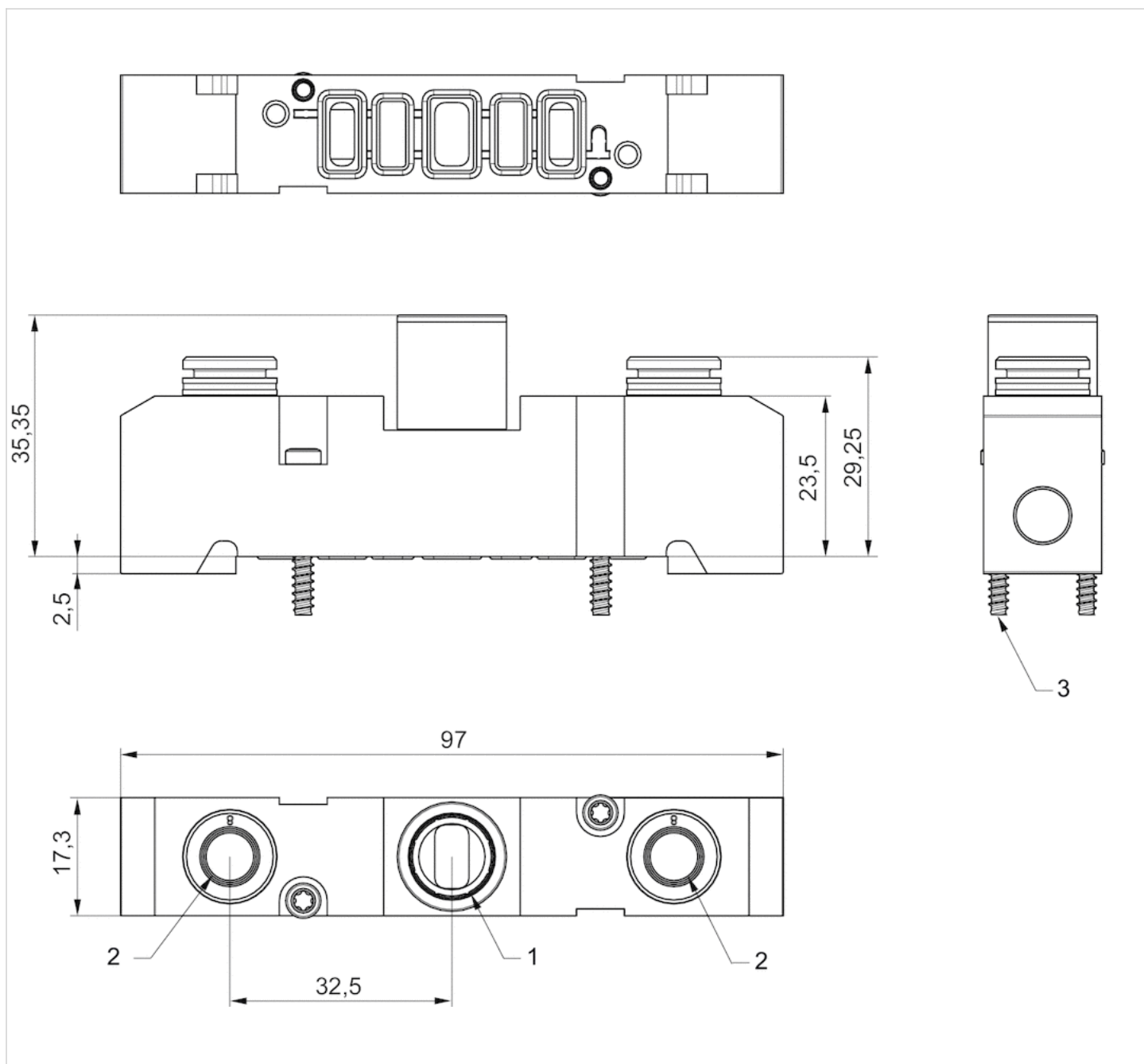

- 1) input [1]  $\varnothing$  12
- 2) Output [3/5]:  $\varnothing$  8
- 3) Screws for plastic  $\varnothing$  3

# Supply plate

- input [1] Ø 3/8
- for ES05 -inch



Working pressure min./max.	0 ... 116 psi
Ambient temperature min./max.	41 ... 122 °F
Medium temperature min./max.	41 ... 122 °F
Medium	Compressed air
Mounting screw	Hexalobular socket (TORX) ISO 10664-10
Tightening torque for mounting screws	0.664 ft./lbs.

## Technical data

Part No.	Compressed air connection Input [1]	Delivery unit
R422103345	Ø 3/8	1 piece
R422P03345	Ø 3/8	5 piece

Delivery includes sealing kit and 2x mounting screw

## Technical information

The pressure dew point must be at least 27 °F under ambient and medium temperature and may not exceed 5.4 °F .  
 The oil content of compressed air must remain constant during the life cycle.  
 Use only the approved oils from AVENTICS. Further information can be found in the "Technical information" document (available in the MediaCentre).

## Technical information

Material	
Seal	Aluminum
Screws	Steel

Dimensions

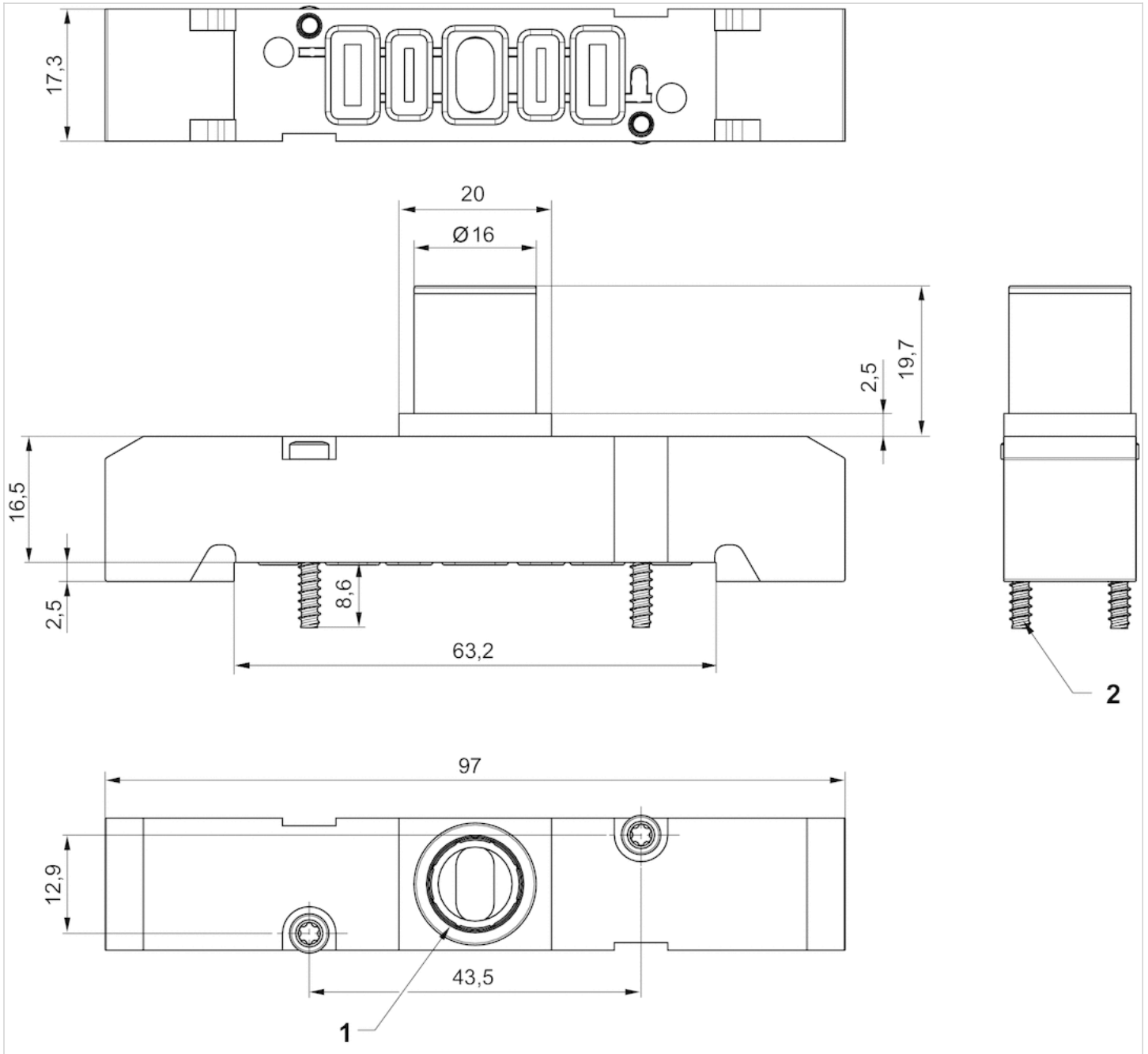

- 1) input [1]  $\text{Ø} 3/8$
- 2) Screws for plastic  $\text{Ø}3$



# Supply plate

- input [1] Ø 3/8, Output [3/5]: Ø3/8

- for ES05 -inch



Working pressure min./max.	0 ... 116 psi
Ambient temperature min./max.	41 ... 122 °F
Medium temperature min./max.	41 ... 122 °F
Medium	Compressed air
Mounting screw	Hexalobular socket (TORX) ISO 10664-10
Tightening torque for mounting screws	0.664 ft./lbs.

## Technical data

Part No.	Compressed air connection Input [1]	Compressed air connection Exhaust [3 / 5]	Delivery unit
R422102810	Ø 3/8	Ø 3/8	1 piece
R422P02810	Ø 3/8	Ø 3/8	5 piece

Delivery includes sealing kit and 2x mounting screw

## Technical information

The pressure dew point must be at least 27 °F under ambient and medium temperature and may not exceed 5.4 °F .

The oil content of compressed air must remain constant during the life cycle.

Use only the approved oils from AVENTICS. Further information can be found in the "Technical information" document (available in the MediaCentre).

## Technical information

Material	
Seal	Aluminum
Screws	Steel

## Dimensions

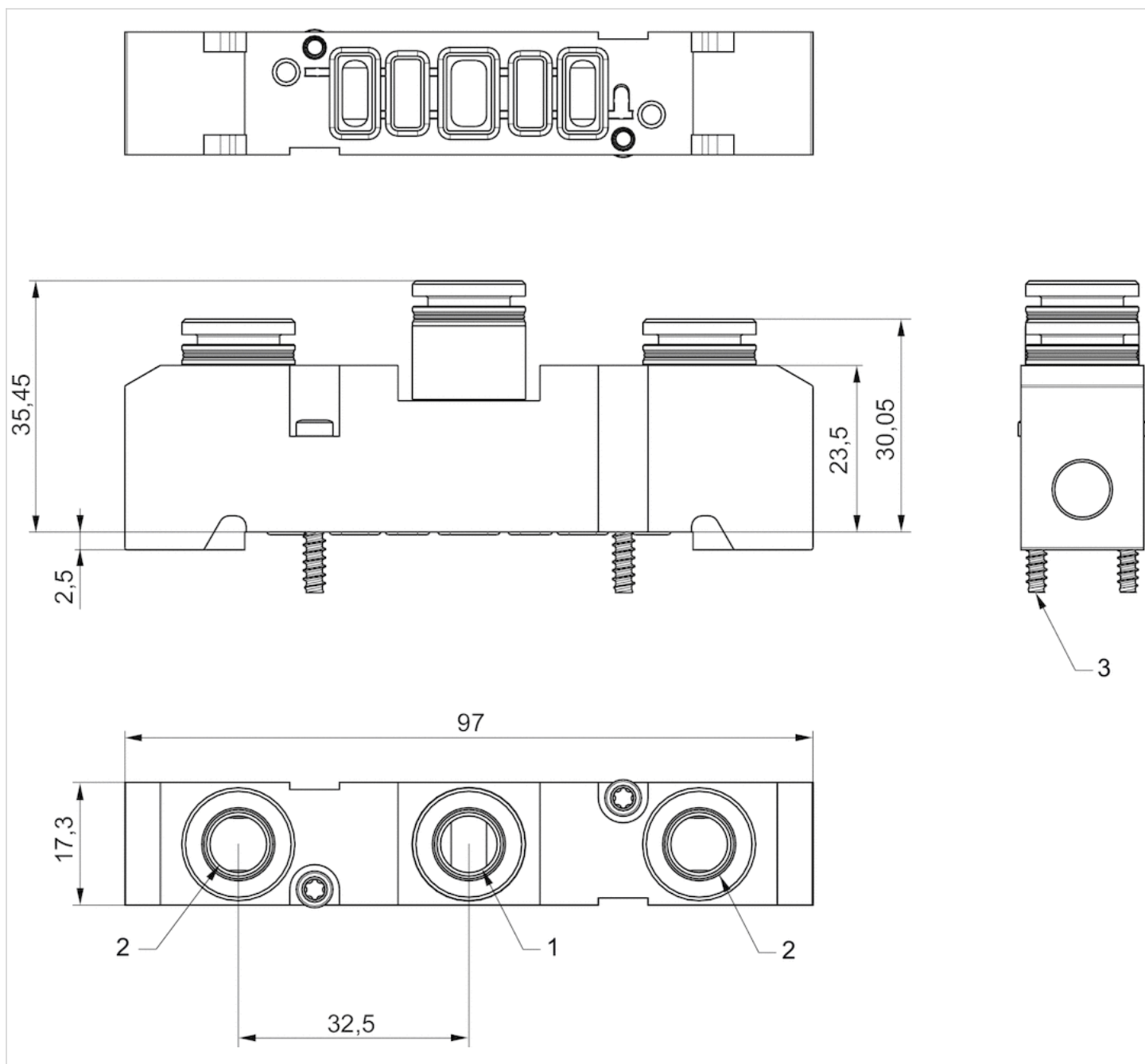

- 1) input [1]  $\varnothing$  3/8
- 2) Output [3/5]:  $\varnothing$  3/8
- 3) Screws for plastic  $\varnothing$  3

# Blanking plate

- for ES05



Ambient temperature min./max.	41 ... 122 °F
Medium temperature min./max.	41 ... 122 °F
Mounting screw	Hexalobular socket (TORX) ISO 10664-10
Tightening torque for mounting screws	0.664 ft./lbs.

## Technical data

Part No.	Delivery unit
R422102718	1 piece
R422P02718	5 piece

Delivery includes sealing kit and 2x mounting screw

## Technical information

The pressure dew point must be at least 27 °F under ambient and medium temperature and may not exceed 5.4 °F .  
 The oil content of compressed air must remain constant during the life cycle.  
 Use only the approved oils from AVENTICS. Further information can be found in the "Technical information" document (available in the MediaCentre).

## Technical information

Material	
Housing	Aluminum
Screws	Steel

## Dimensions

### Dimensions

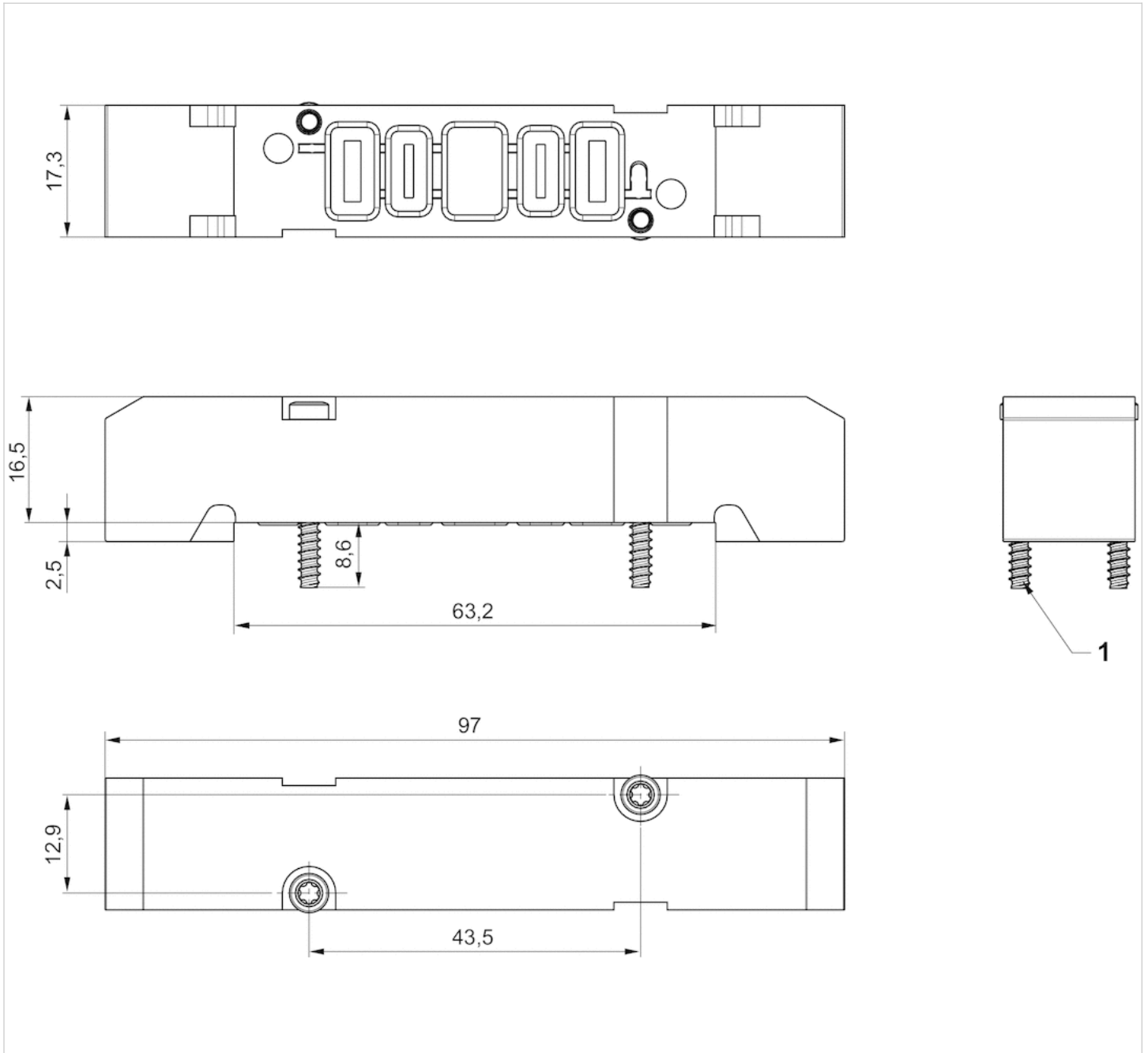

1) Screws for plastic Ø3

# Single subbase, Series ES05

- Compressed air connection output : Base plate
- Manual override : without detent
- single solenoid double solenoid
- With spring/air spring return



Activation	Electrically
Working pressure min./max.	44 ... 116 psi
Ambient temperature min./max.	41 ... 122 °F
Medium temperature min./max.	41 ... 122 °F
Medium	Compressed air
Max. particle size	40 µm
Oil content of compressed air	0 ... 5 mg/m <sup>3</sup>
Protection class with connection	IP65
Duty cycle	100 %

## Technical data

Part No.	Compressed air connection	
	Input	Output
R422102746	Ø 8	Base plate
R422102747	Ø 8	Base plate

Part No.	Compressed air connection		Operational voltage	Voltage tolerance
	Exhaust			
R422102746	Ø 8		DC	DC
R422102747	Ø 8		24 V	-15% / +10%

Part No.	Power consumption		Fig.
	DC		
R422102746	2 W		Fig. 1
R422102747	2 W		Fig. 2

Nominal flow Qn at 87 psi and  $\Delta p = 14.5$  psi

## Technical information

The min. control pressure must be adhered to, since otherwise faulty switching and valve failure may result!  
 The pressure dew point must be at least 27 °F under ambient and medium temperature and may not exceed 5.4 °F .  
 The oil content of compressed air must remain constant during the life cycle.  
 Use only the approved oils from AVENTICS. Further information can be found in the "Technical information" document (available in the MediaCentre).

## Technical information

Material

Housing

Polyamide Polyoxymethylene

## Dimensions

Fig. 1, single solenoid

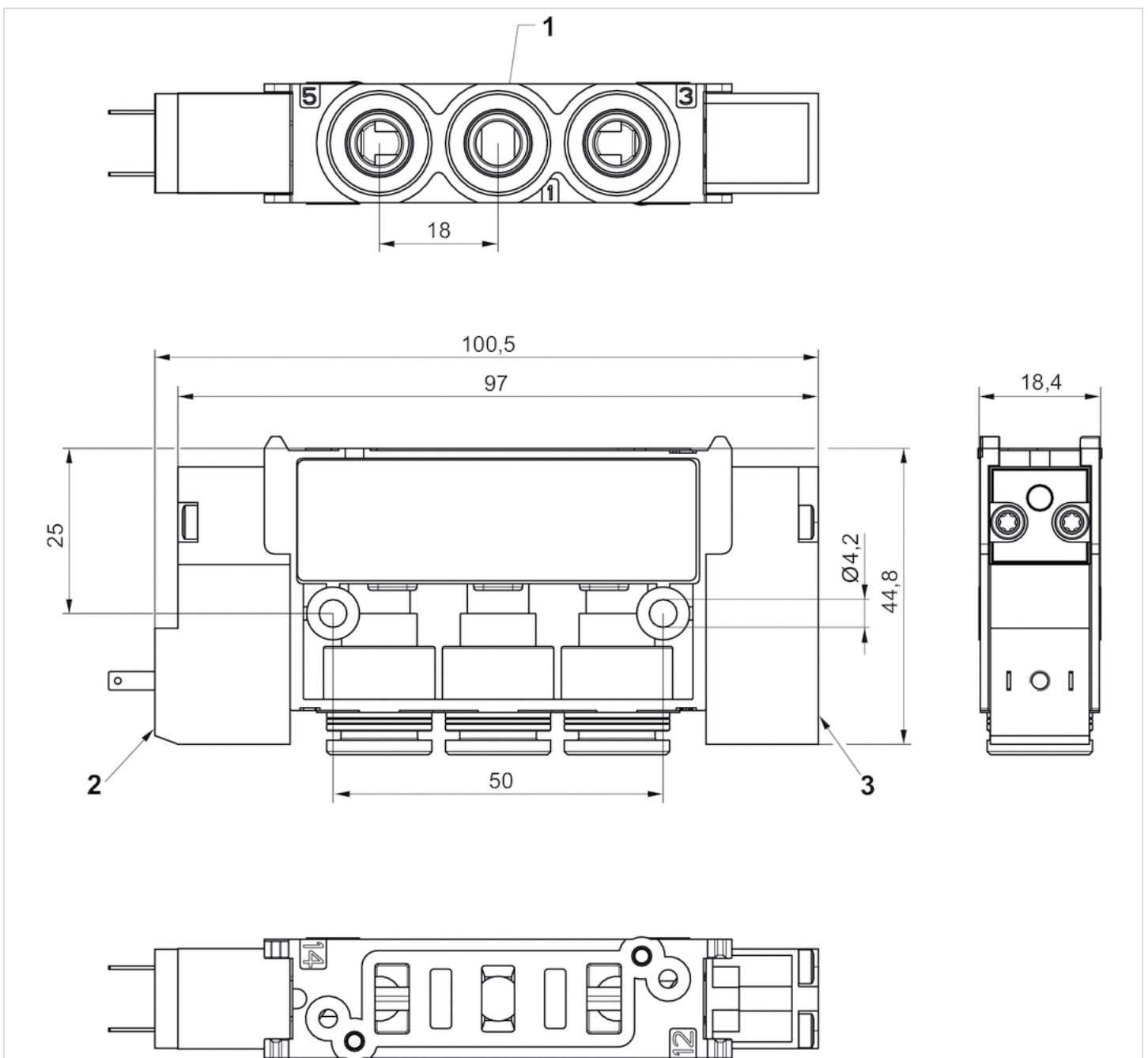

- 1) Connections [1 ,3 ,5]  $\varnothing 8$
- 2) Pilot valve with external electrical control
- 3) Pilot blanking plate

Fig. 2, double solenoid

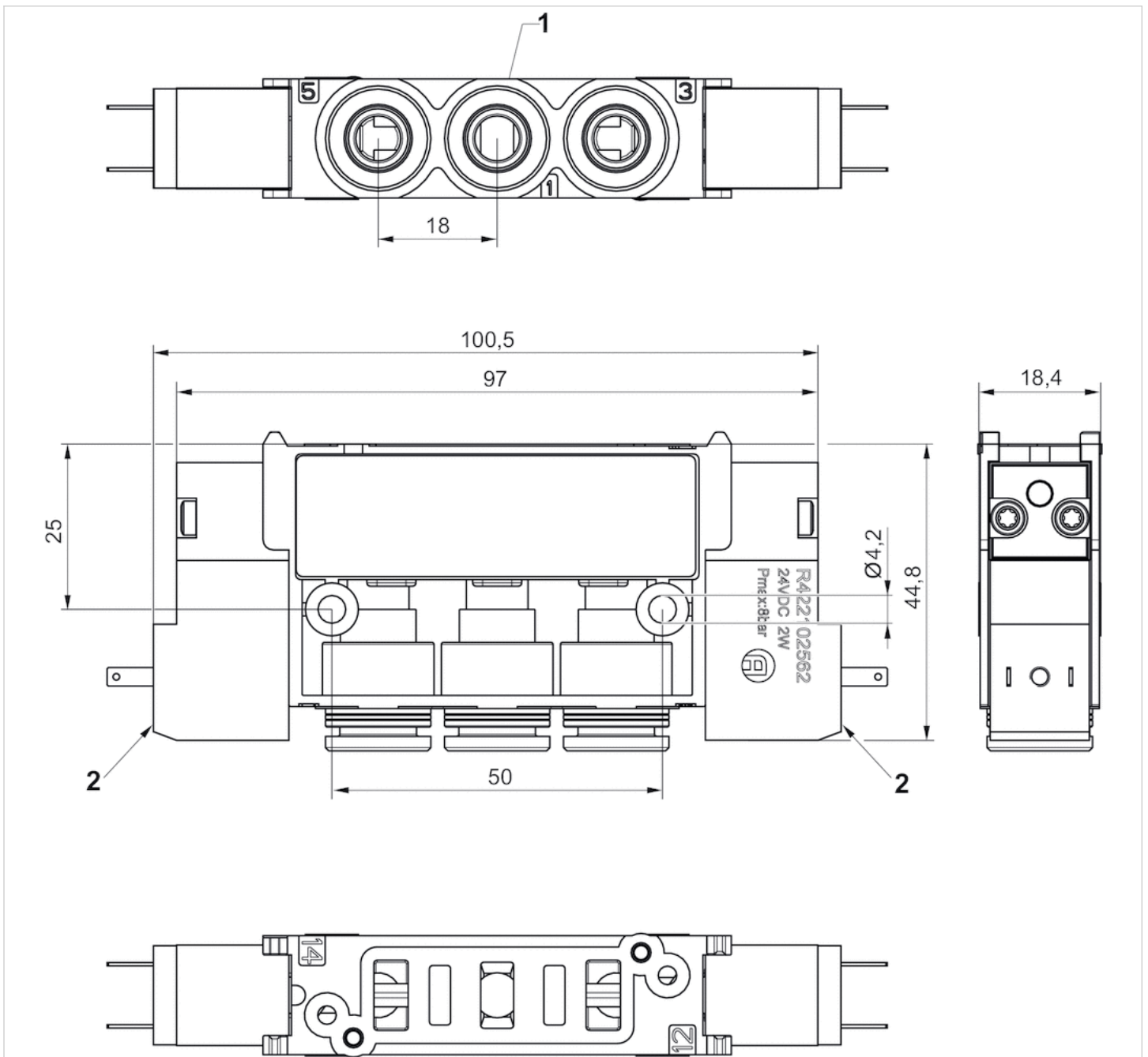

- 1) Connections [1 ,3 ,5] Ø 8
- 2) Pilot valve with external electrical control

# Single subbase, Series ES05

- Compressed air connection output : Base plate
- Electrical connection : M8, 3-pin
- Manual override : without detent
- single solenoid double solenoid
- With spring/air spring return



Activation	Electrically
Working pressure min./max.	44 ... 116 psi
Ambient temperature min./max.	41 ... 122 °F
Medium temperature min./max.	41 ... 122 °F
Medium	Compressed air
Max. particle size	40 µm
Oil content of compressed air	0 ... 5 mg/m <sup>3</sup>
Protection class with connection	IP65
Duty cycle	100 %

## Technical data

Part No.	Compressed air connection	
	Input	Output
R422103850	Ø 8	Base plate
R422103851	Ø 8	Base plate

Part No.	Compressed air connection		Operational voltage	Voltage tolerance
	Exhaust			
R422103850	Ø 8		DC	DC
R422103851	Ø 8		24 V	-15% / +10%

Part No.	Power consumption		Fig.
	DC		
R422103850	2 W		Fig. 1
R422103851	2 W		Fig. 2

Nominal flow Q<sub>n</sub> at 87 psi and Δp = 14.5 psi

## Technical information

The min. control pressure must be adhered to, since otherwise faulty switching and valve failure may result!  
 The pressure dew point must be at least 27 °F under ambient and medium temperature and may not exceed 5.4 °F .  
 The oil content of compressed air must remain constant during the life cycle.  
 Use only the approved oils from AVENTICS. Further information can be found in the "Technical information" document (available in the MediaCentre).



## Technical information

Material

Housing

Polyamide Polyoxymethylene

## Dimensions

Fig. 1, single solenoid

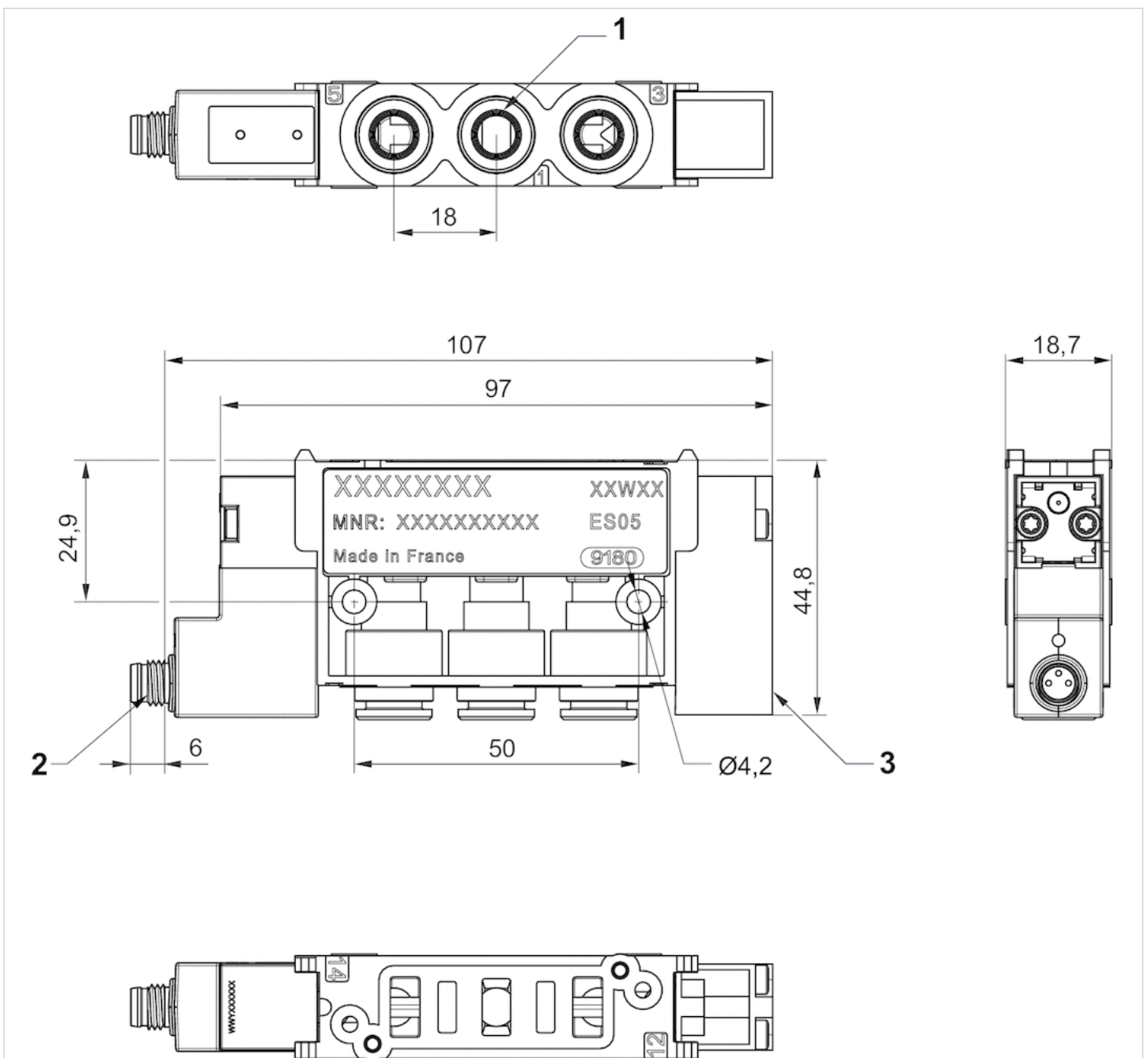

- 1) Connections [1 ,3 ,5]  $\varnothing 8$
- 2) Pilot valve with external electrical control: M8x1
- 3) Pilot blanking plate

Fig. 2, double solenoid

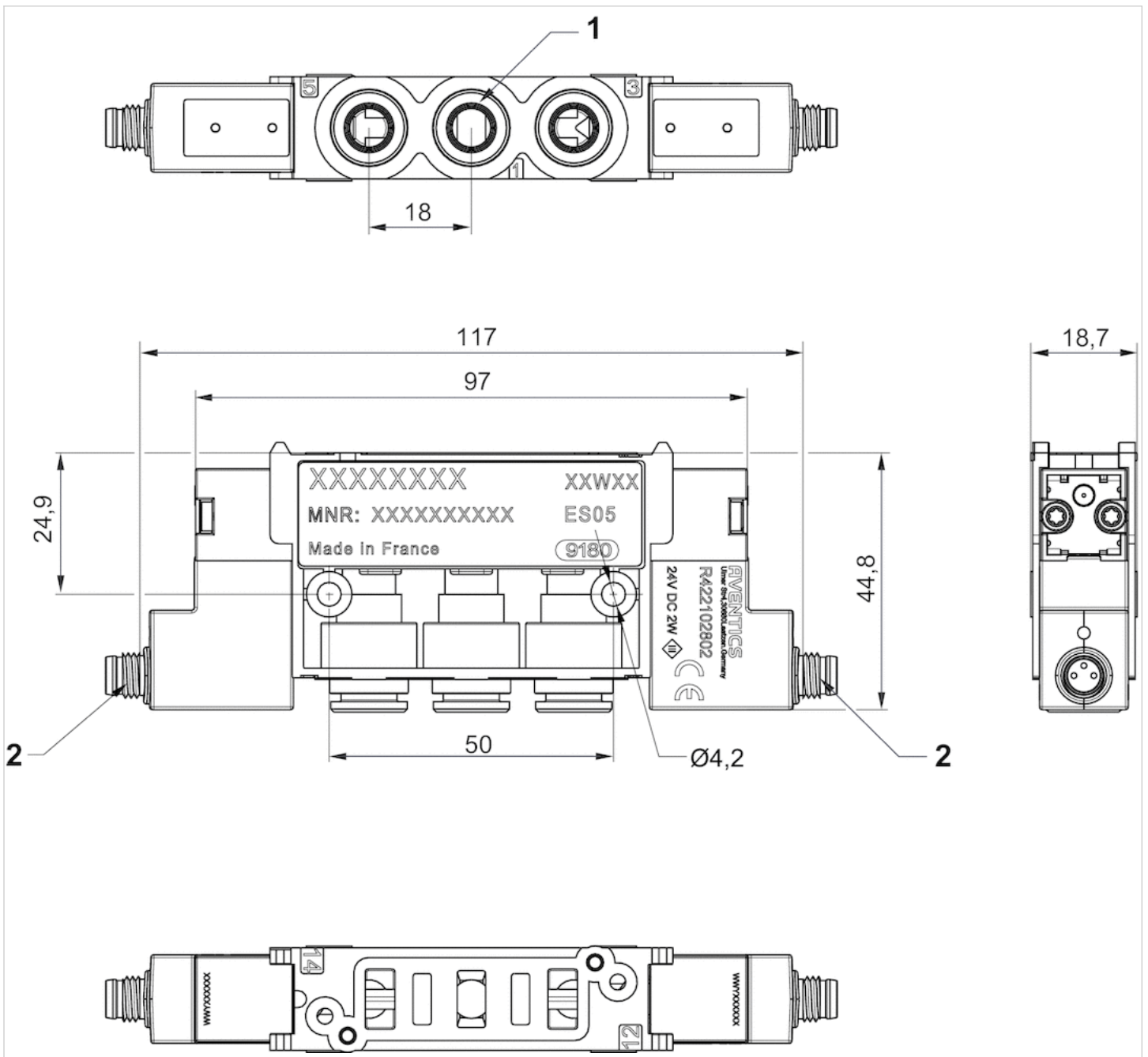

- 1) Connections [1 ,3 ,5] Ø 8
- 2) Pilot valve with external electrical control: M8x1

## Pin assignments

### PIN assignment for valve plug connectors

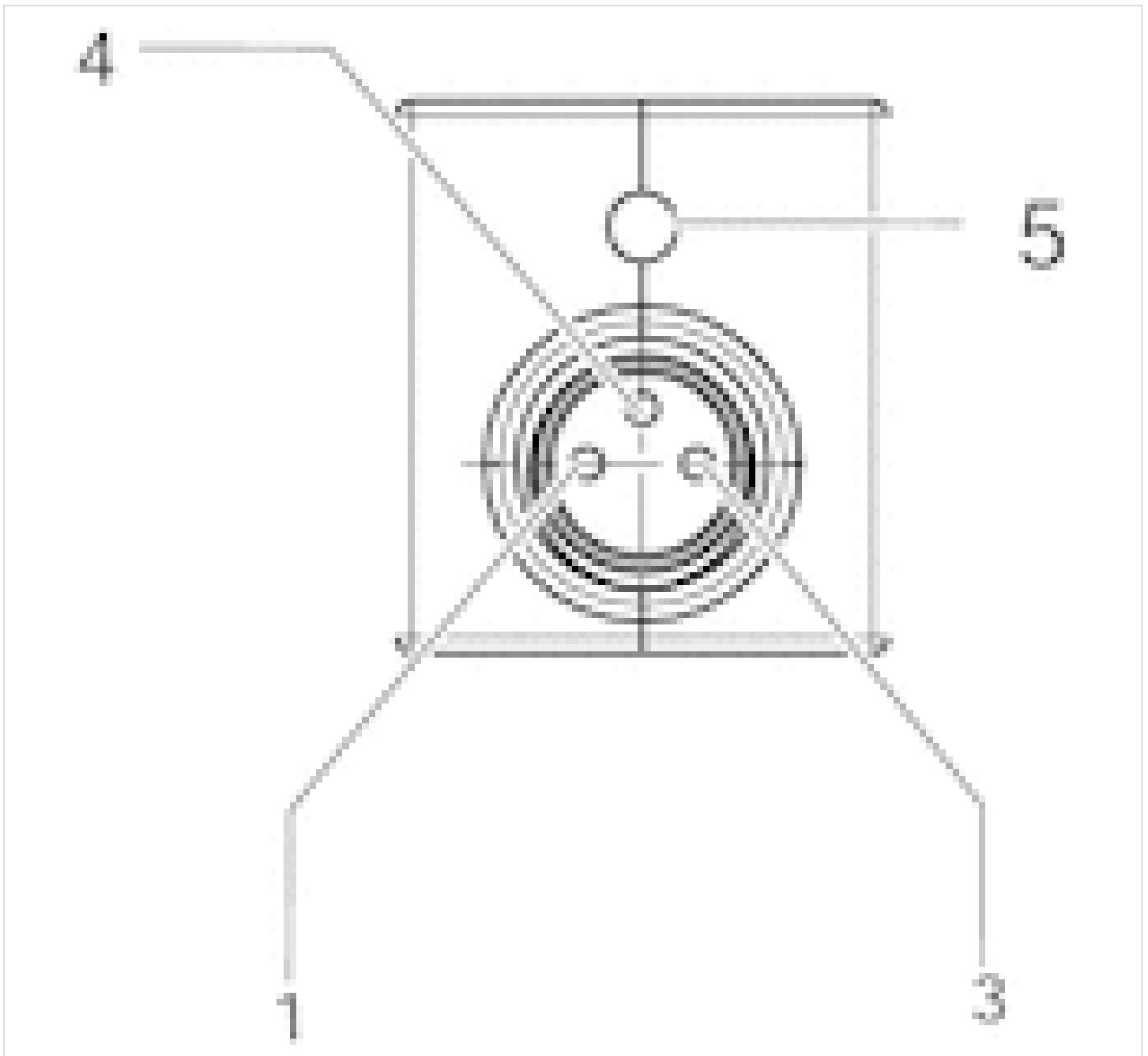

Pin assignment:

- 1) Pin not assigned
- 3) 0 V
- 4) 24 V
- 5) LED

Note: Bi-polar protective circuit to prevent overvoltage

# Single subbase, Series ES05 -inch

- Compressed air connection output : Base plate
- Manual override : without detent
- single solenoid double solenoid



Activation	Electrically
Working pressure min./max.	0 ... 116 psi
Ambient temperature min./max.	41 ... 122 °F
Medium temperature min./max.	41 ... 122 °F
Medium	Compressed air
Max. particle size	40 µm
Oil content of compressed air	0 ... 5 mg/m <sup>3</sup>
Protection class with connection	IP65
Duty cycle	100 %

## Technical data

Part No.	Compressed air connection	
	Input	Output
R422102748	Ø 3/8	Base plate
R422102749	Ø 3/8	Base plate

Part No.	Compressed air connection		Operational voltage	Voltage tolerance
	Exhaust			
R422102748	Ø 3/8		DC	DC
R422102749	Ø 3/8		24 V	-15% / +10%

Part No.	Power consumption		Fig.
	DC		
R422102748	2 W		Fig. 1
R422102749	2 W		Fig. 2

Nominal flow Qn at 87 psi and  $\Delta p = 14.5$  psi

## Technical information

The pressure dew point must be at least 27 °F under ambient and medium temperature and may not exceed 5.4 °F .

The oil content of compressed air must remain constant during the life cycle.

Use only the approved oils from AVENTICS. Further information can be found in the "Technical information" document (available in the MediaCentre).

## Technical information

Material	
Housing	Polyamide Polyoxymethylene



Fig. 1, single solenoid

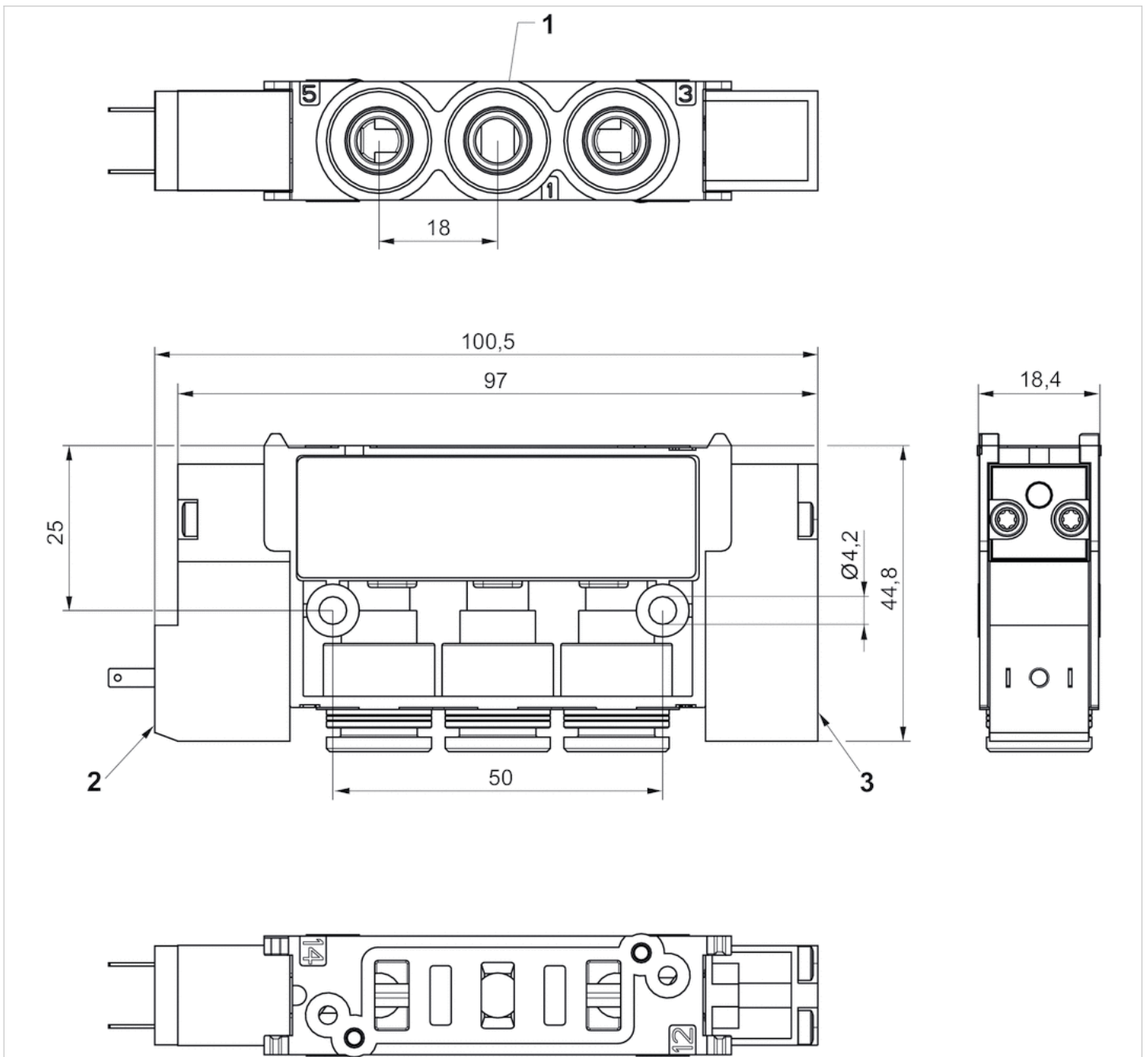

- 1) Connections [1 ,3 ,5, 2, 4]  $\varnothing$  3/8
- 2) Pilot valve with external electrical control
- 3) Pilot blanking plate

# Single subbase, Series ES05 -inch

- Compressed air connection output : Base plate
- Electrical connection : M8, 3-pin
- Manual override : without detent
- single solenoid double solenoid



Activation	Electrically
Working pressure min./max.	0 ... 116 psi
Ambient temperature min./max.	41 ... 122 °F
Medium temperature min./max.	41 ... 122 °F
Medium	Compressed air
Max. particle size	40 µm
Oil content of compressed air	0 ... 5 mg/m <sup>3</sup>
Protection class with connection	IP65
Duty cycle	100 %

## Technical data

Part No.	Compressed air connection	
	Input	Output
R422103852	Ø 3/8	Base plate
R422103853	Ø 3/8	Base plate

Part No.	Compressed air connection		Operational voltage	Voltage tolerance
	Exhaust			
R422103852	Ø 3/8		DC	DC
R422103853	Ø 3/8		24 V	-15% / +10%

Part No.	Power consumption		Fig.
	DC		
R422103852	2 W		Fig. 1
R422103853	2 W		Fig. 2

Nominal flow Qn at 87 psi and  $\Delta p = 14.5$  psi

## Technical information

The min. control pressure must be adhered to, since otherwise faulty switching and valve failure may result!

The pressure dew point must be at least 27 °F under ambient and medium temperature and may not exceed 5.4 °F .

The oil content of compressed air must remain constant during the life cycle.

Use only the approved oils from AVENTICS. Further information can be found in the "Technical information" document (available in the MediaCentre).

## Technical information

Material

Housing

Polyamide Polyoxymethylene

## Dimensions

Fig. 1, single solenoid

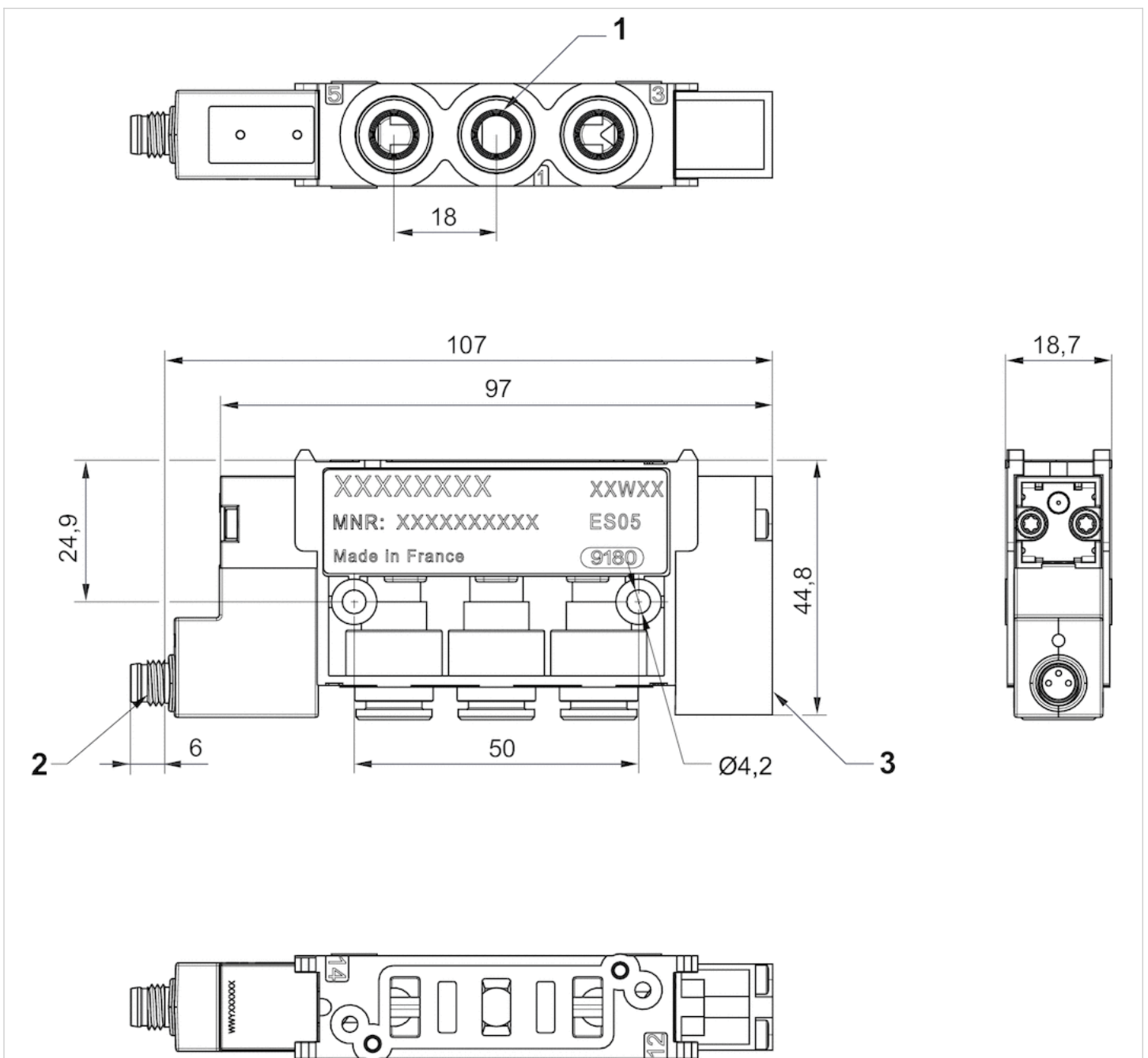

- 1) Connections [1 ,3 ,5, 2, 4] Ø 3/8
- 2) Pilot valve with external electrical control: M8x1
- 3) Pilot blanking plate



Fig. 2, double solenoid

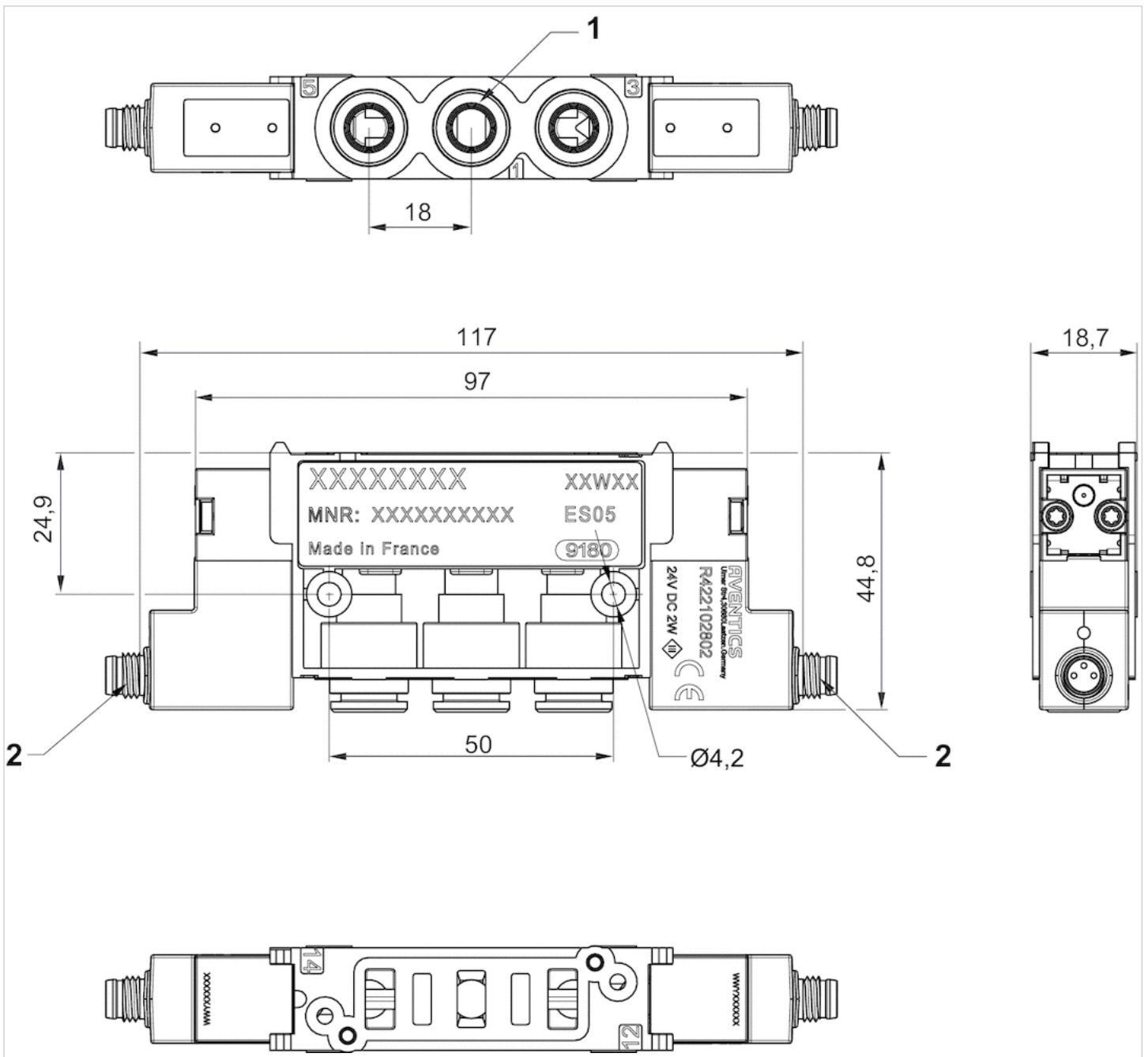

- 1) Connections [1 ,3 ,5, 2, 4] Ø 3/8
- 2) Pilot valve with external electrical control: M8x1

## Pin assignments

### PIN assignment for valve plug connectors

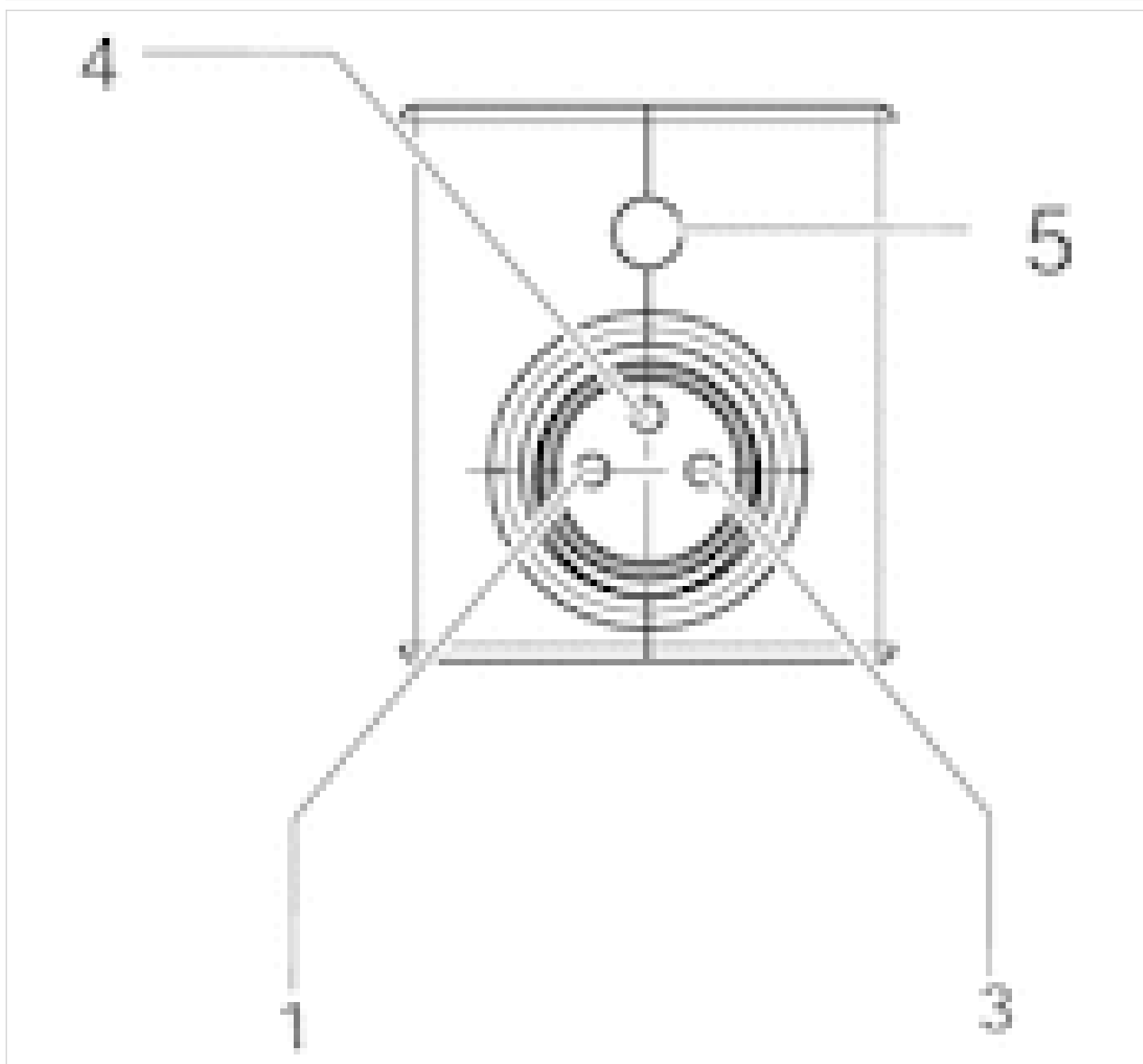

Pin assignment:

- 1) Pin not assigned
- 3) 0 V
- 4) 24 V
- 5) LED

Note: Bi-polar protective circuit to prevent overvoltage

# Pilot valve, Series ES05

- Pilot valve for internal electrical control
- Electrical connection : form C, industry
- Manual override : without detent



Activation	Electrically
Control pressure min./max.	44 ... 116 psi
Ambient temperature min./max.	41 ... 122 °F
Medium temperature min./max.	41 ... 122 °F
Medium	Compressed air
mounting screws	Hexalobular socket (TORX) ISO 10664-10
Mounting screw tightening torque	0.664 ft./lbs.
Tightening torque tolerance	±0,1 mT

## Technical data

Part No.	Operational voltage	Voltage tolerance	Power consumption	Delivery unit
		DC	DC	
R422003356	24 V	-15% / +10%	2 W	1 piece
R422P03356	24 V	-15% / +10%	2 W	5 piece

## Technical information

The min. control pressure must be adhered to, since otherwise faulty switching and valve failure may result!  
 The pressure dew point must be at least 27 °F under ambient and medium temperature and may not exceed 5.4 °F .  
 The oil content of compressed air must remain constant during the life cycle.  
 Use only the approved oils from AVENTICS. Further information can be found in the "Technical information" document (available in the MediaCentre).

Coil for single wiring connection, rotatable

## Technical information

Material	
Housing	Polyamide
Seals	Acrylonitrile butadiene rubber

## Dimensions

### Dimensions

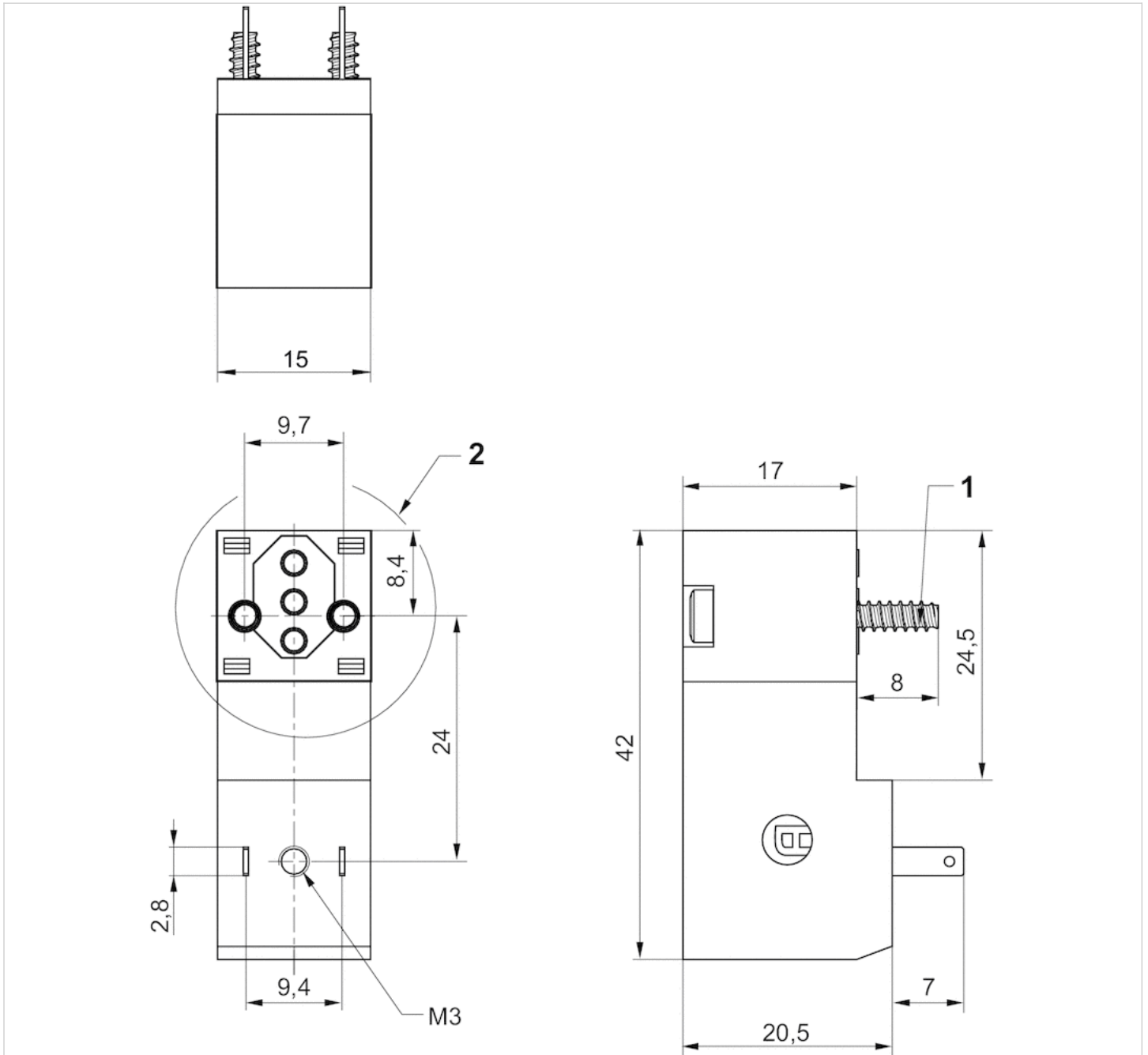

- 1) Screws for plastic Ø3
- 2) rotatable 90°

# Pilot valve, Series ES05

- Pilot valve with external electrical connection, Single wiring
- Electrical connection : form C, industry
- Manual override : without detent



Activation	Electrically
Control pressure min./max.	44 ... 116 psi
Ambient temperature min./max.	41 ... 122 °F
Medium temperature min./max.	41 ... 122 °F
Duty cycle	100 %
mounting screws	Hexalobular socket (TORX) ISO 10664-10
Mounting screw tightening torque	0.664 ft./lbs.
Tightening torque tolerance	±0,1 mT

## Technical data

Part No.	Operational voltage	Voltage tolerance	Power consumption	Delivery unit
		DC	DC	
R422003357	24 V	-15% / +10%	2 W	1 piece
R422P03357	24 V	-15% / +10%	2 W	5 piece

## Technical information

The min. control pressure must be adhered to, since otherwise faulty switching and valve failure may result!  
 The pressure dew point must be at least 27 °F under ambient and medium temperature and may not exceed 5.4 °F .  
 The oil content of compressed air must remain constant during the life cycle.  
 Use only the approved oils from AVENTICS. Further information can be found in the "Technical information" document (available in the MediaCentre).

Coil for internal electrical control, rotatable

## Technical information

Material	
Housing	Polyamide
Seals	Acrylonitrile butadiene rubber

## Dimensions

## Dimensions

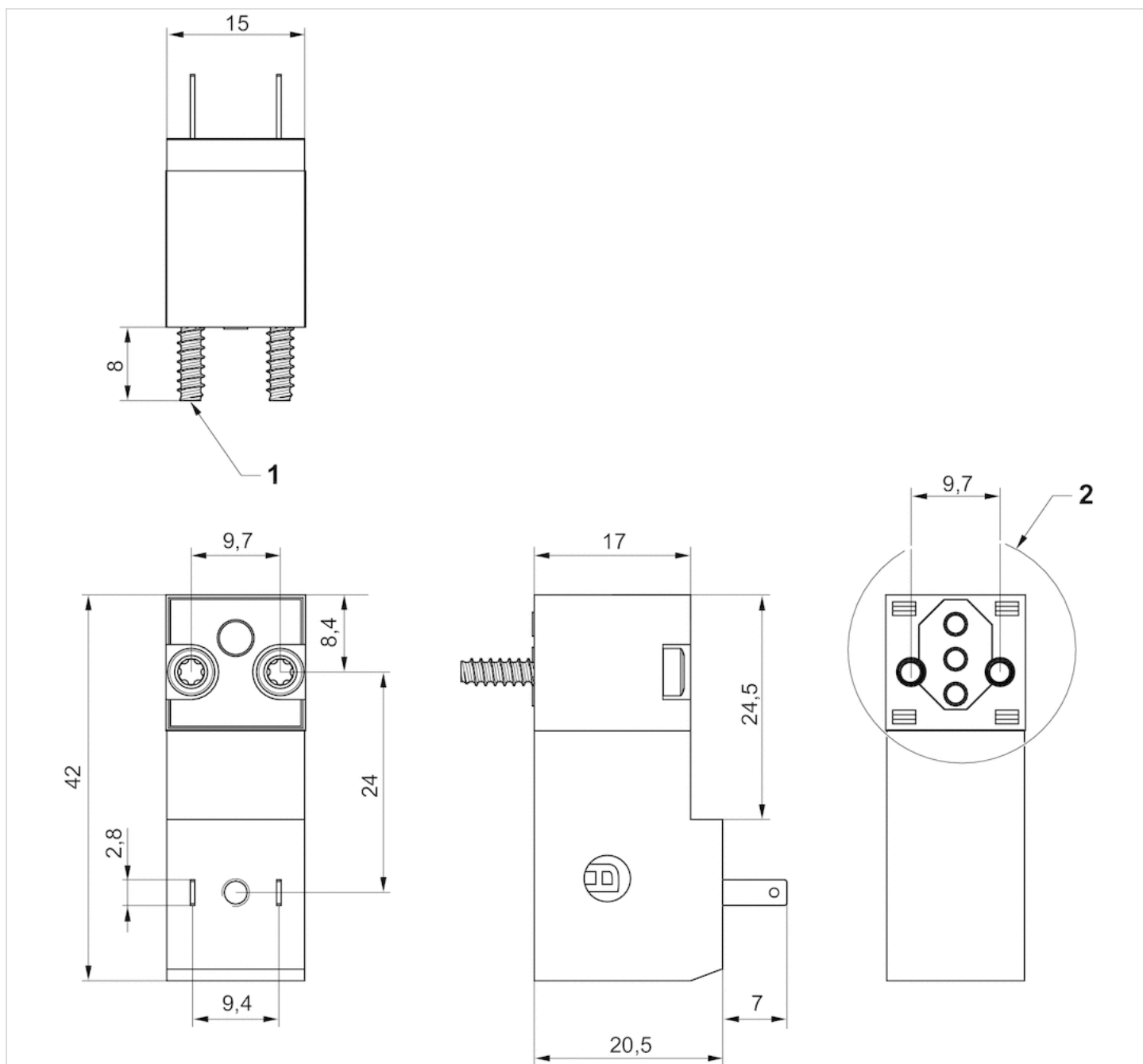

1) Screws for plastic Ø3

2) rotatable 90°

# Pilot valve, Series ES05

- Pilot valve with external electrical connection, Single wiring
- Electrical connection : M8x1, 3-pin



Activation	Electrically
Control pressure min./max.	44 ... 116 psi
Ambient temperature min./max.	41 ... 122 °F
Medium temperature min./max.	41 ... 122 °F
Duty cycle	100 %
mounting screws	Hexalobular socket (TORX) ISO 10664-10
Mounting screw tightening torque	0.664 ft./lbs.
Tightening torque tolerance	±0,1 mT

## Technical data

Part No.	Operational voltage	Voltage tolerance	Power consumption	Delivery unit
	DC	DC	DC	
R422P03854	24 V	-15% / +10%	2 W	5 piece
R422103854	24 V	-15% / +10%	2 W	1 piece

## Technical information

The min. control pressure must be adhered to, since otherwise faulty switching and valve failure may result!  
 The pressure dew point must be at least 27 °F under ambient and medium temperature and may not exceed 5.4 °F .  
 The oil content of compressed air must remain constant during the life cycle.  
 Use only the approved oils from AVENTICS. Further information can be found in the "Technical information" document (available in the MediaCentre).

## Technical information

Material	
Housing	Polyamide
Seals	Acrylonitrile butadiene rubber

# Dimensions

## Dimensions

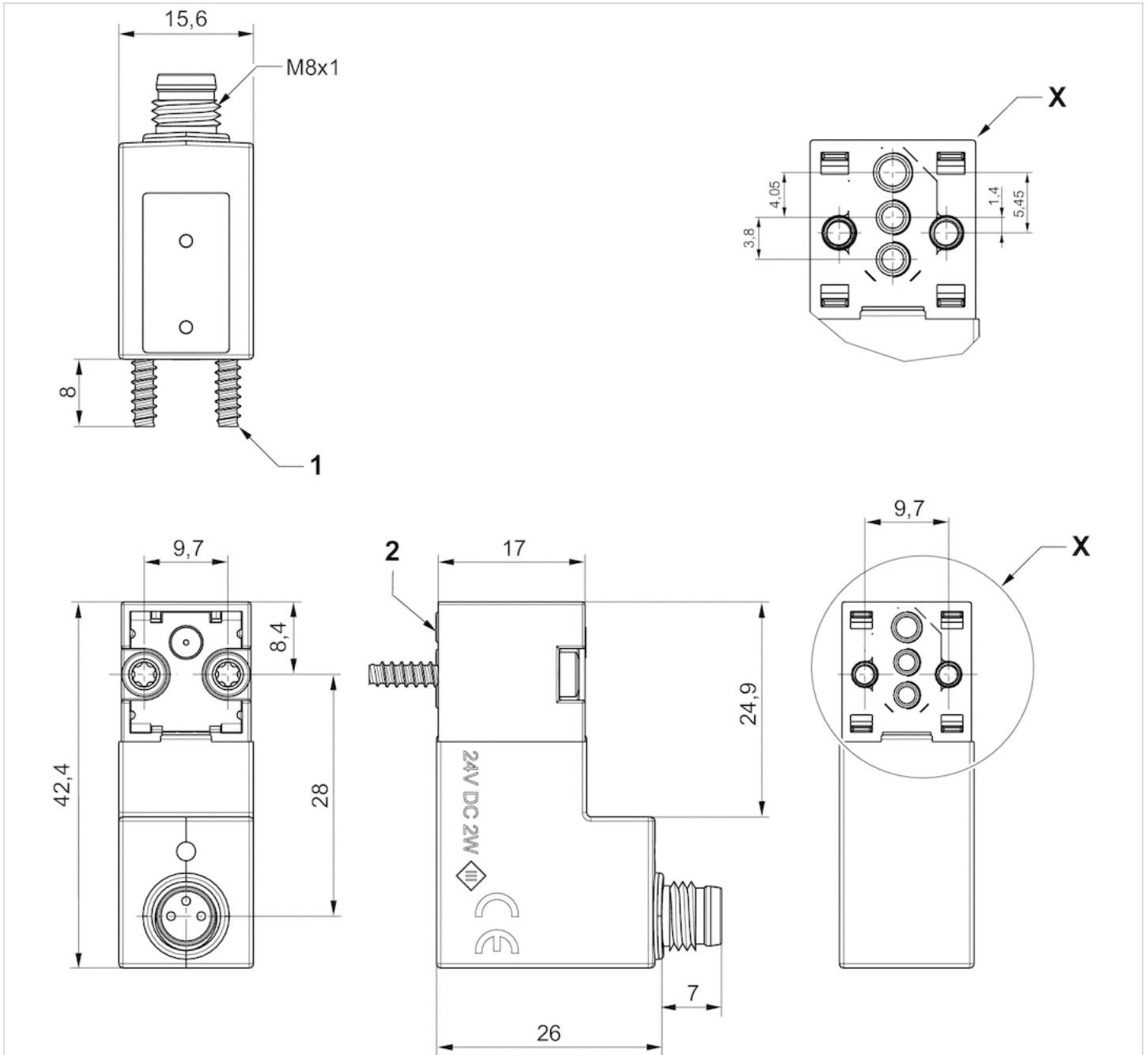

- 1) Screws for plastic Ø3
- 2) rotatable 90°



## Pin assignments

### PIN assignment for valve plug connectors

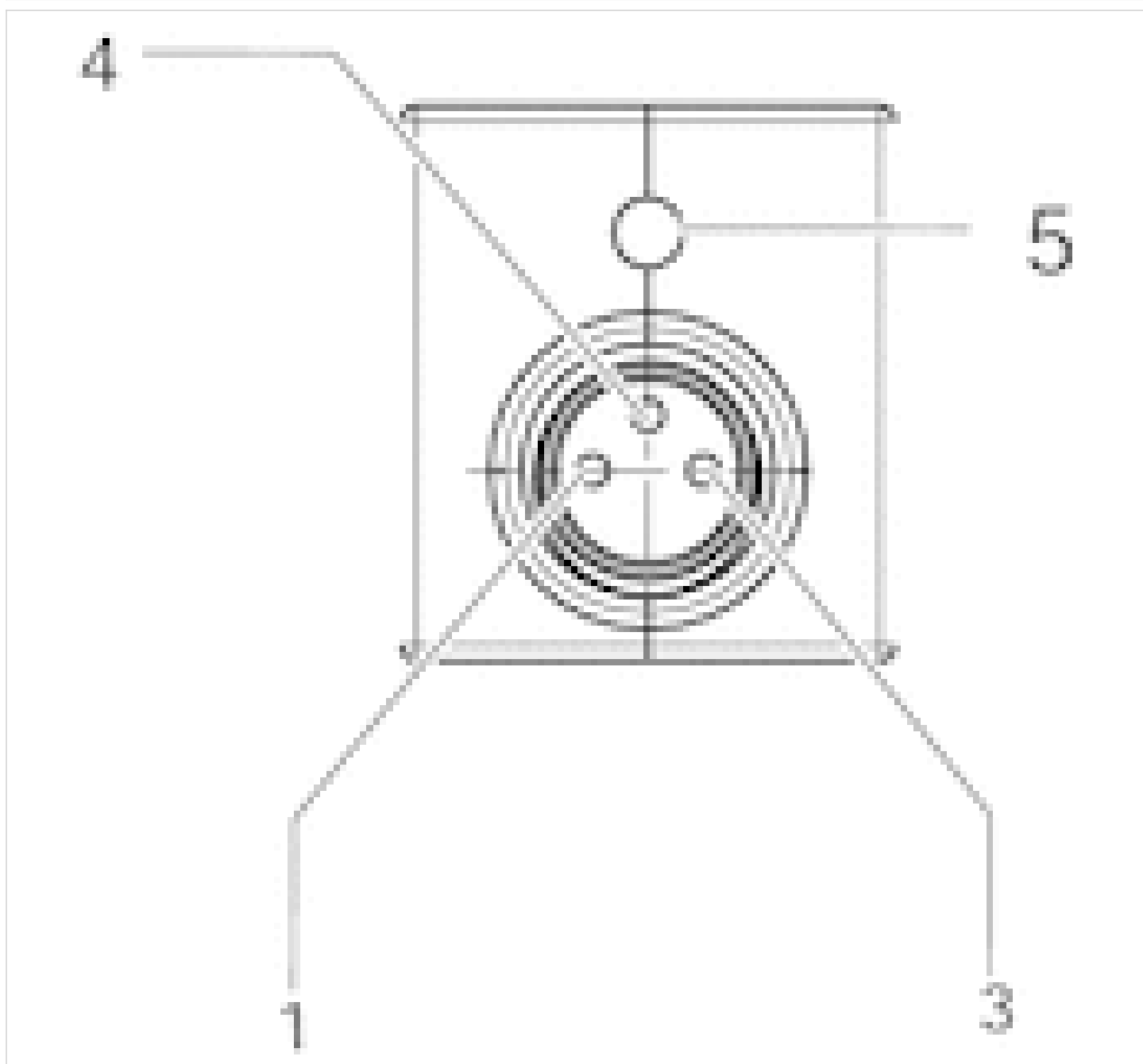

Pin assignment:

- 1) Pin not assigned
- 3) 0 V
- 4) 24 V
- 5) LED

Note: Bi-polar protective circuit to prevent overvoltage

# QR1-S-RPN standard series

- Straight fitting
- External thread
- G 1/8 G 3/8
- push-in fitting
- Ø 4 Ø 12
- QR1-S-RPN



Working pressure min./max.	-13 ... 145 psi
Ambient temperature min./max.	32 ... 140 °F
Weight per piece	See table below

## Technical data

Part No.	Port G	Port D	Delivery unit	Weight per piece
2121004180	G 1/8	Ø 4	10 piece	0.031 lbs
2121012380	G 3/8	Ø 12	10 piece	0.099 lbs

## Technical information

The series QR1 (plastic) and QR2 (metal) can not be combined  
Thread seal with captive O-ring

For further information about assembling and tolerances of adaptable tubing can be found in the "Technical information" document (available in the MediaCentre).

## Technical information

Material	
Material	nickel-plated
Housing	Brass, nickel-plated
Seal	Acrylonitrile butadiene rubber
Tooth lock washer	Stainless steel
Release ring	Polyoxymethylene
Release ring holder	Die cast zinc Brass, nickel-plated
Thread	Brass, nickel-plated

Dimensions

Dimensions

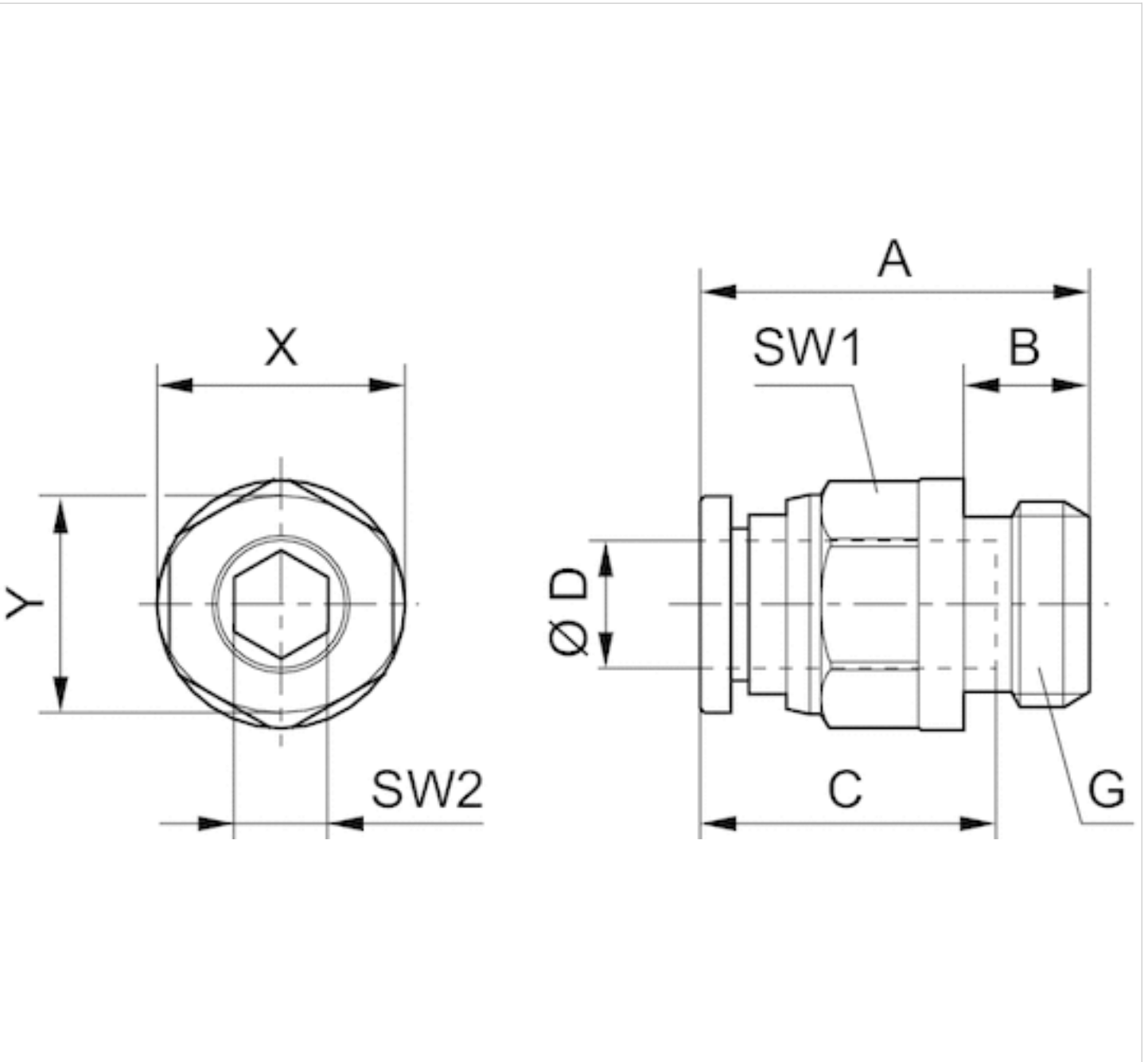

Dimensions

Part No.	Port D	Port G	A	B	C	SW1	SW2	X	Y
2121004180	Ø 4	G 1/8	20.1	5	16	10	3	12	10
2121012380	Ø 12	G 3/8	33.5	7	23	21	9	23	21

# QR1-S-RVT standard series

- Elbow fitting
- External thread
- G 1/8 G 3/8
- push-in fitting
- Ø 4 Ø 12
- QR1-S-RVT



Working pressure min./max.	-13 ... 145 psi
Ambient temperature min./max.	32 ... 140 °F
Weight per piece	See table below

## Technical data

Part No.	Port G	Port D	Delivery unit	Weight per piece
2122004180	G 1/8	Ø 4	10 piece	0.027 lbs
2122012380	G 3/8	Ø 12	10 piece	0.096 lbs

## Technical information

The series QR1 (plastic) and QR2 (metal) can not be combined  
Thread seal with captive O-ring

For further information about assembling and tolerances of adaptable tubing can be found in the "Technical information" document (available in the MediaCentre).

## Technical information

Material	
Material	nickel-plated
Housing	Polybutyleneterephthalate
Seal	Acrylonitrile butadiene rubber
Tooth lock washer	Stainless steel
Release ring	Polyoxymethylene
Release ring holder	Die cast zinc Brass, nickel-plated
Thread	Brass, nickel-plated

Dimensions

Dimensions

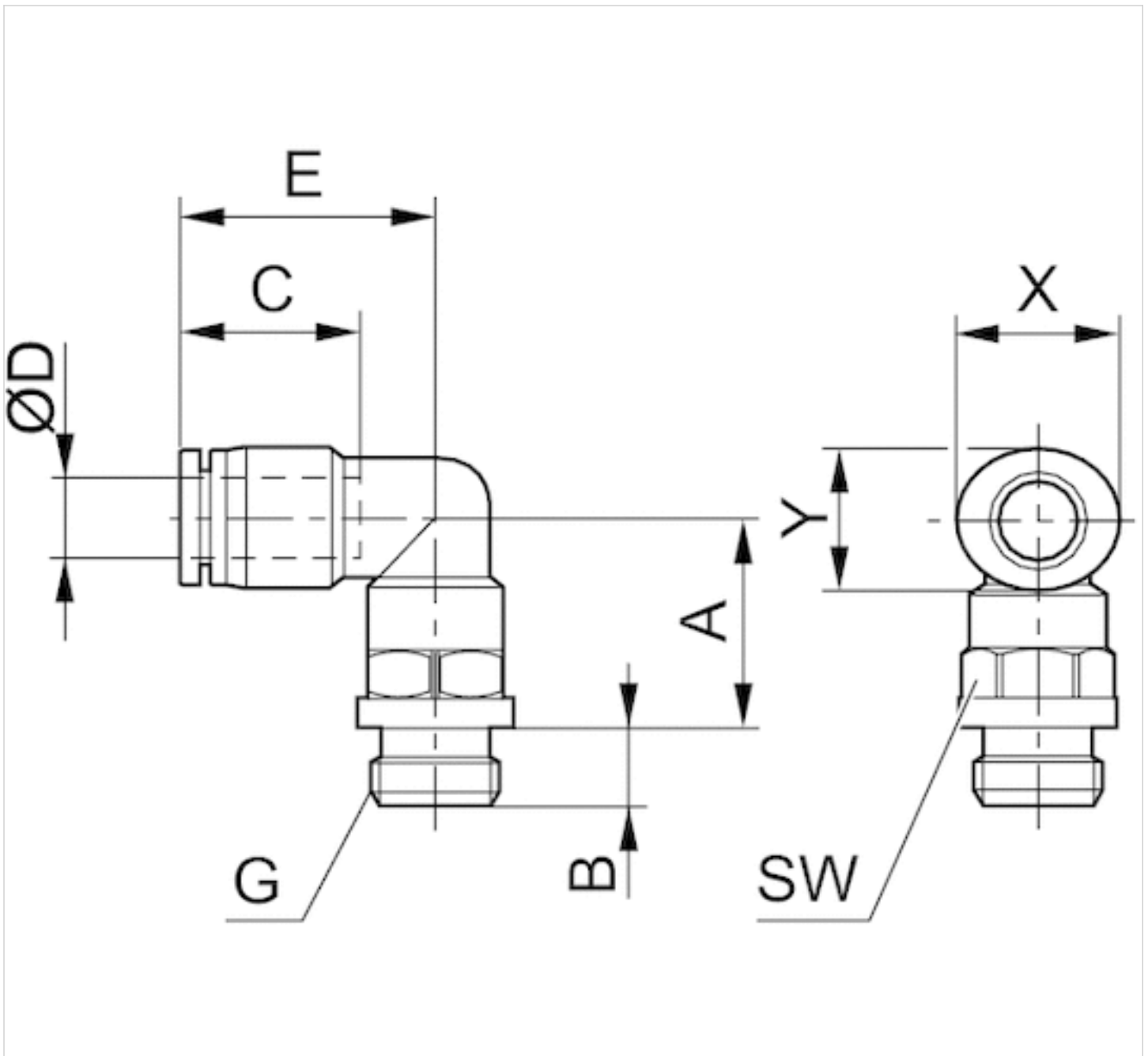

Dimensions

Part No.	Port D	Port G	A	B	C	E	SW	X	Y
2122004180	Ø 4	G 1/8	9.5	5	16	18.5	13	12	10
2122012380	Ø 12	G 3/8	15.3	7	22.5	29.2	20	23	21

# QR1-S-RED standard series

- Straight push-in fitting, reducing
- push-in fitting
- Ø 4 Ø 6
- pin bushing
- Ø 8
- QR1-S-RED



Working pressure min./max.	-13 ... 145 psi
Ambient temperature min./max.	32 ... 140 °F
Weight per piece	See table below

## Technical data

Part No.	Port G	Port D	Delivery unit	Weight per piece
2121708040	Ø 4	Ø 8	10 piece	0.008 lbs
2121708060	Ø 6	Ø 8	10 piece	0.009 lbs

## Technical information

The series QR1 (plastic) and QR2 (metal) can not be combined

For further information about assembling and tolerances of adaptable tubing can be found in the "Technical information" document (available in the MediaCentre).

## Technical information

Material	
Material	nickel-plated
Housing	Polybutyleneterephthalate
Seal	Acrylonitrile butadiene rubber
Tooth lock washer	Stainless steel
Release ring	Polyoxymethylene
Release ring holder	Die cast zinc Brass, nickel-plated

Dimensions

Dimensions

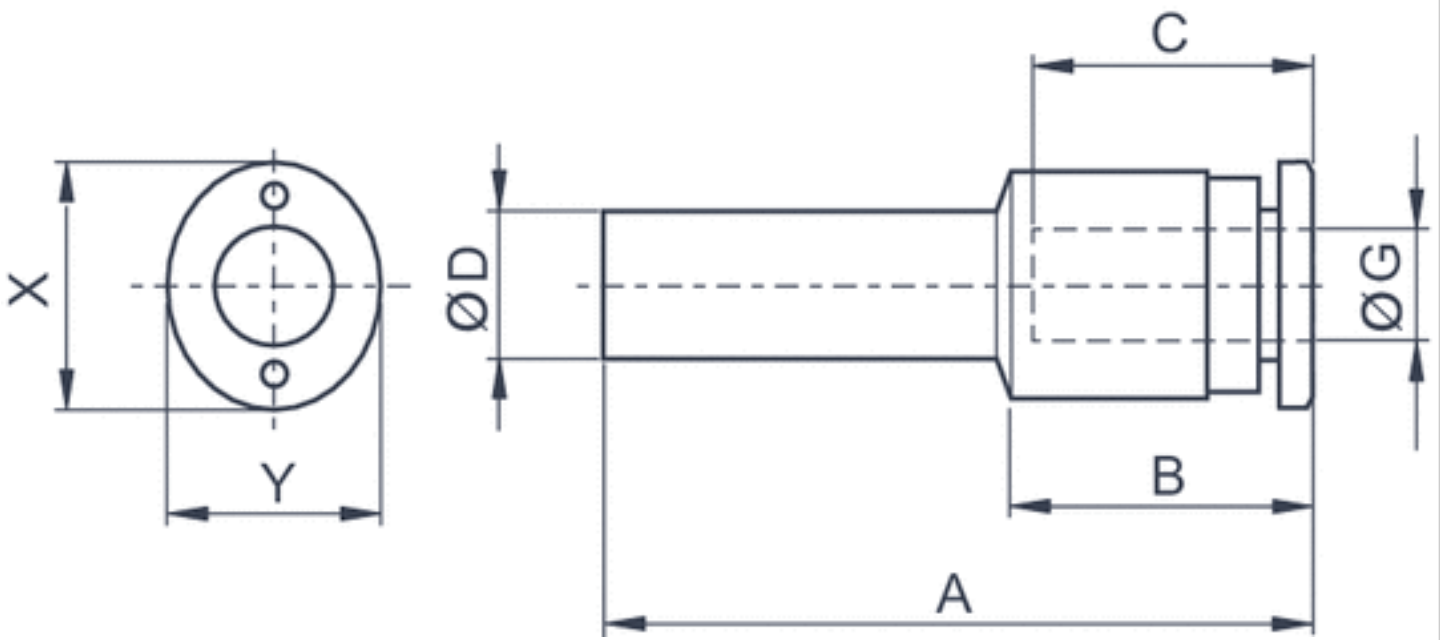

Dimensions

Part No.	Port D	Port G	A	B	C Insertion depth	X	Y
2121708040	Ø 8	Ø 4	42.6	18.2	16	12	10
2121708060	Ø 8	Ø 6	43.3	19.2	17	14	12

# QR1-S-RED standard series

- Straight push-in fitting, reducing
- push-in fitting
- Ø5/16 Ø1/4
- pin bushing
- Ø 3/8
- QR1-S-RED



Working pressure min./max.	-13 ... 145 psi
Ambient temperature min./max.	32 ... 140 °F
Weight per piece	0.011 lbs

## Technical data

Part No.	Port G	Port D	Delivery unit
R432000068	Ø5/16	Ø 3/8	10 piece
R432000067	Ø1/4	Ø 3/8	10 piece

## Technical information

The series QR1 (plastic) and QR2 (metal) can not be combined

These pneumatic components with NPT or inch thread dimensions are only available from our US sales organization.

For further information about assembling and tolerances of adaptable tubing can be found in the "Technical information" document (available in the MediaCentre).

## Technical information

Material	
Material	nickel-plated
Housing	Polybutyleneterephthalate
Seal	Acrylonitrile butadiene rubber
Tooth lock washer	Stainless steel
Release ring	Polyoxymethylene
Release ring holder	Die cast zinc Brass, nickel-plated



## Dimensions

### Dimensions in inches

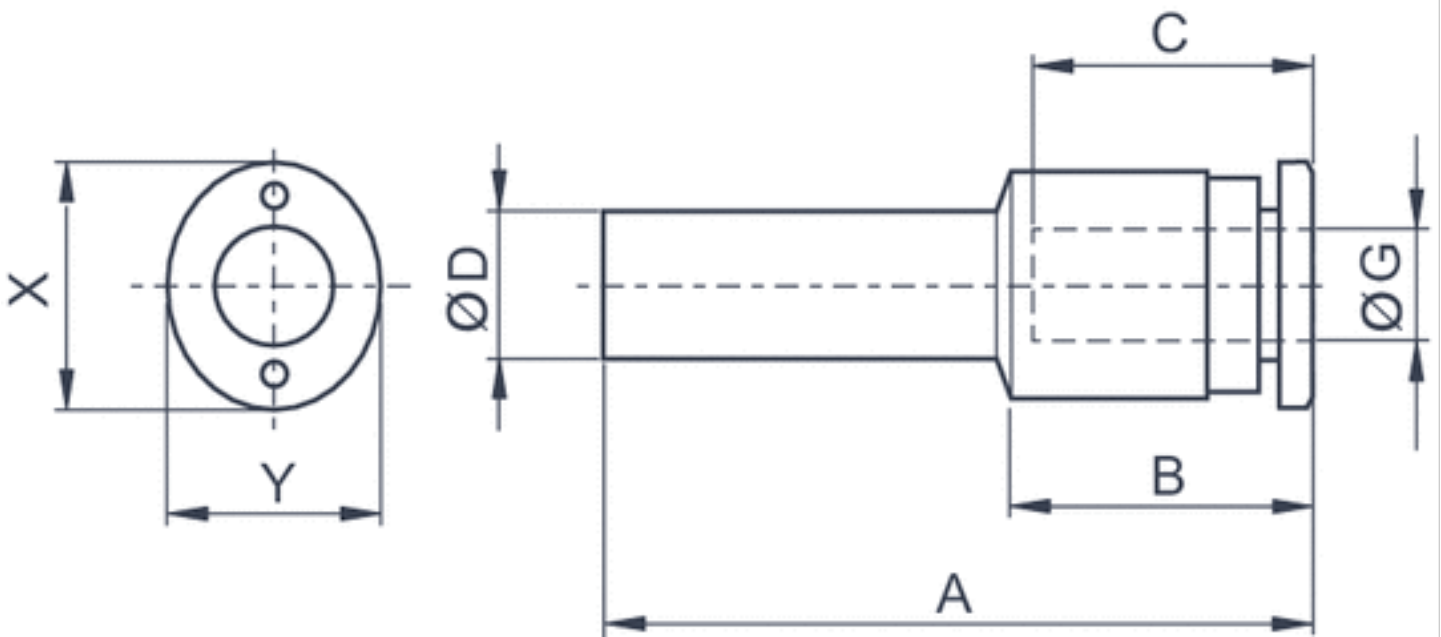

### Dimensions in inches

Part No.	Port D	Port G	A	B	C	X	Y
R432000068	Ø 3/8	Ø5/16	1.872	0.801	0.827	0.63	0.552
R432000067	Ø 3/8	Ø1/4	1.82	0.756	0.827	0.552	0.473

# QR1-S-RVA standard series

- Angled plug-in connector
- pin bushing
- Ø 8
- push-in fitting
- Ø 8
- QR1-S-RVA



Working pressure min./max.	-13 ... 145 psi
Ambient temperature min./max.	32 ... 140 °F
Weight per piece	0.018 lbs

## Technical data

Part No.	Port G	Port D	Delivery unit
2121308080	Ø 8	Ø 8	10 piece

## Technical information

The series QR1 (plastic) and QR2 (metal) can not be combined

For further information about assembling and tolerances of adaptable tubing can be found in the "Technical information" document (available in the MediaCentre).

## Technical information

Material	
Material	nickel-plated
Housing	Polybutyleneterephthalate
Seal	Acrylonitrile butadiene rubber
Tooth lock washer	Stainless steel
Release ring	Polyoxymethylene
Release ring holder	Die cast zinc Brass, nickel-plated

Dimensions

Dimensions

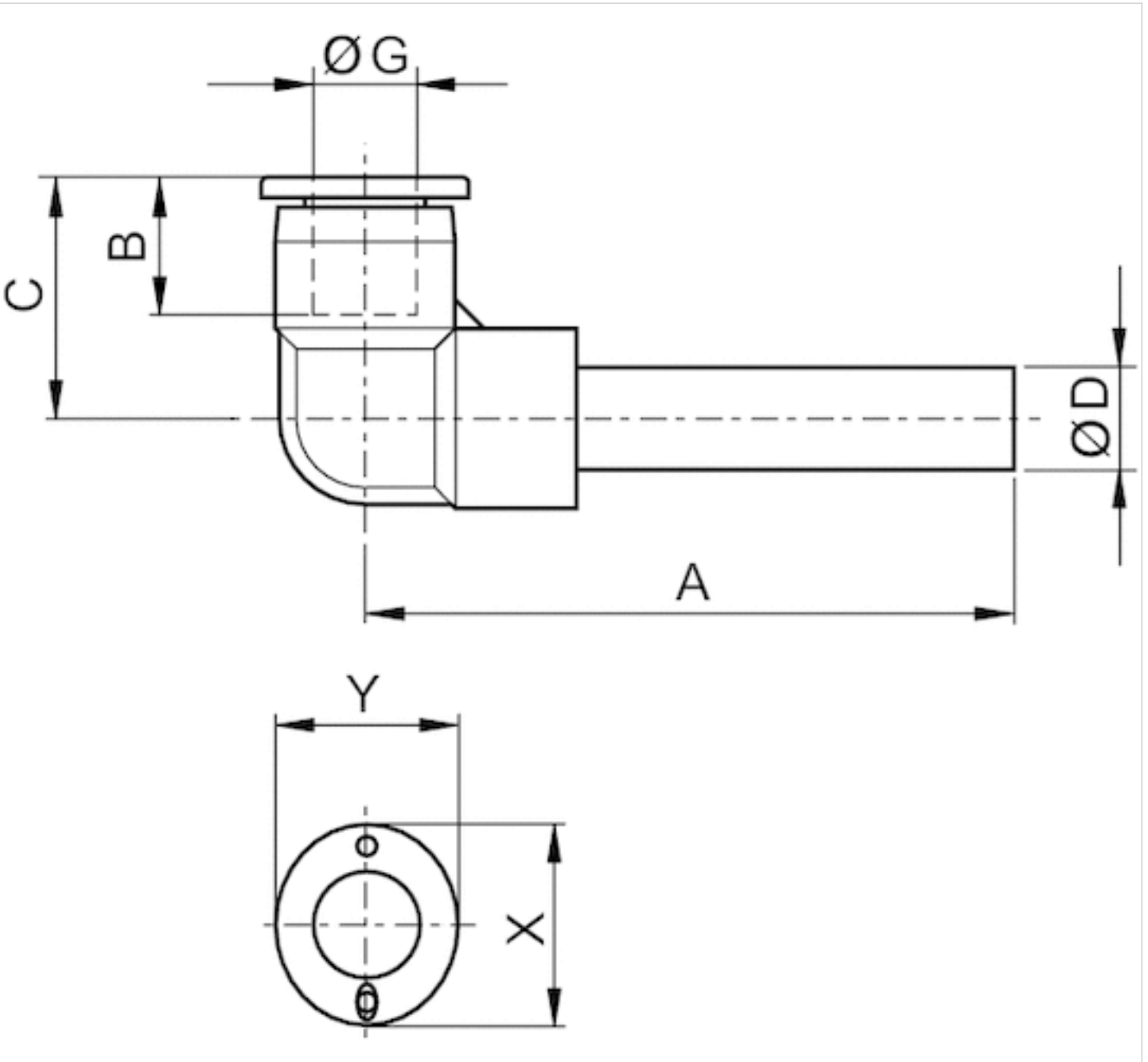

Dimensions

Part No.	Port D	Port G	A	B Insertion depth	C	X	Y
2121308080	$\varnothing 8$	$\varnothing 8$	42	18.5	22.8	16	14

# QR1-S-RLL standard series

- Angled plug-in connector
- Pin bushing, long
- Ø 8
- push-in fitting
- Ø 8
- QR1-S-RLL



Working pressure min./max.	-13 ... 145 psi
Ambient temperature min./max.	32 ... 140 °F
Weight per piece	0.019 lbs

## Technical data

Part No.	Port G	Port D	Delivery unit
R412005041	Ø 8	Ø 8	10 piece

## Technical information

The series QR1 (plastic) and QR2 (metal) can not be combined

For further information about assembling and tolerances of adaptable tubing can be found in the "Technical information" document (available in the MediaCentre).

## Technical information

Material	
Material	nickel-plated
Housing	Polybutyleneterephthalate
Seal	Acrylonitrile butadiene rubber
Tooth lock washer	Stainless steel
Release ring	Polyoxymethylene
Release ring holder	Die cast zinc Brass, nickel-plated

Dimensions

Dimensions

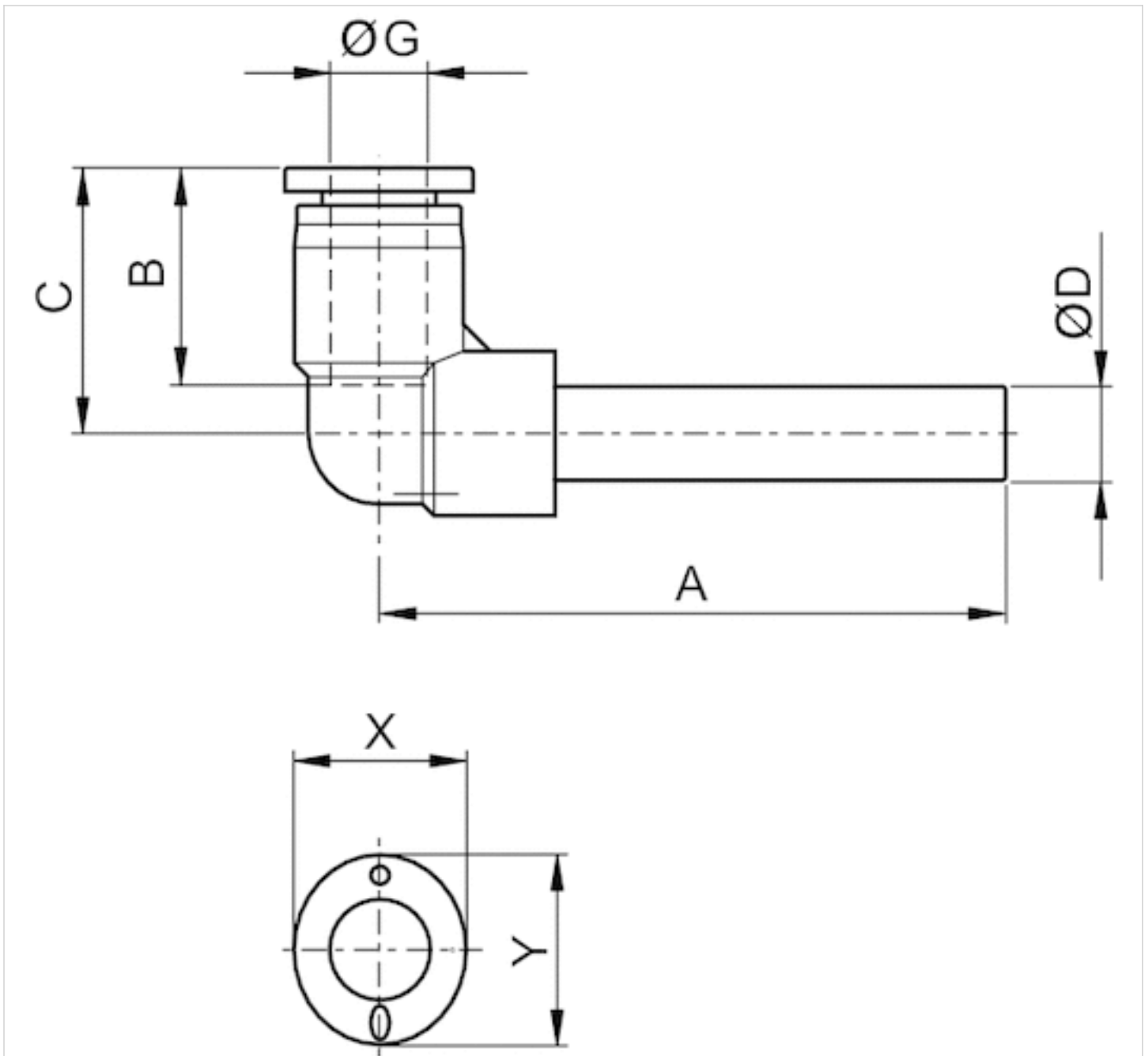

Dimensions

Part No.	Port D	Port G	A	B	C	X	Y
R412005041	Ø 8	Ø 8	54.5	18.5	22.8	16	14

# QR1-S-RLL standard series

- Angled plug-in connector, long
- pin bushing
- Ø 3/8
- push-in fitting
- Ø 3/8
- QR1-S-RLL



Working pressure min./max.	-13 ... 145 psi
Ambient temperature min./max.	32 ... 140 °F
Weight per piece	0.031 lbs

## Technical data

Part No.	Port G	Port D	Delivery unit
R432000090	Ø 3/8	Ø 3/8	10 piece

## Technical information

The series QR1 (plastic) and QR2 (metal) can not be combined

These pneumatic components with NPT or inch thread dimensions are only available from our US sales organization.

For further information about assembling and tolerances of adaptable tubing can be found in the "Technical information" document (available in the MediaCentre).

## Technical information

Material	
Material	nickel-plated
Housing	Polybutyleneterephthalate
Seal	Acrylonitrile butadiene rubber
Tooth lock washer	Stainless steel
Release ring	Polyoxymethylene
Release ring holder	Die cast zinc Brass, nickel-plated

## Dimensions

### Dimensions in inches

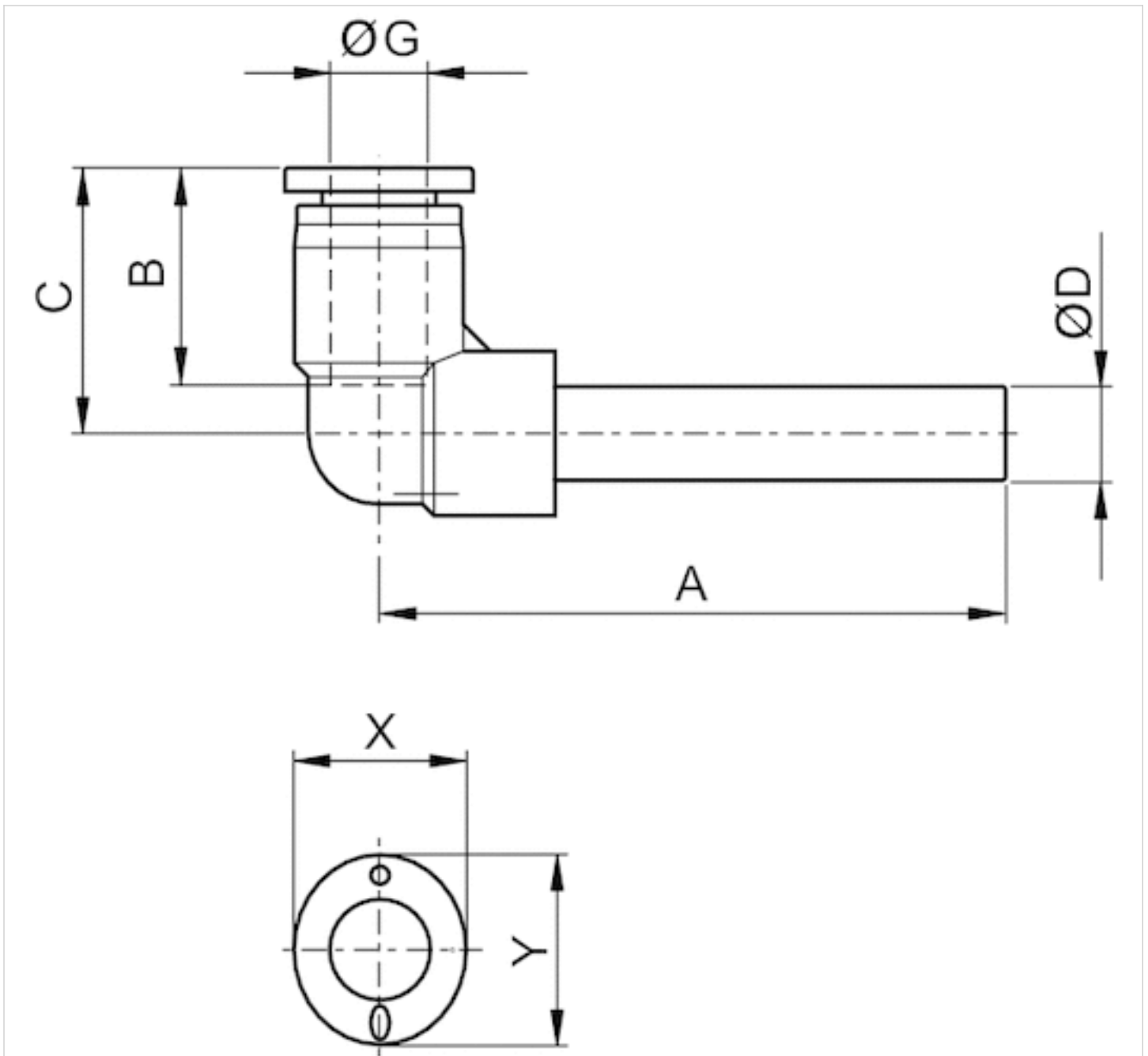

### Dimensions in inches

Part No.	Port D	Port G	A	B	C	X	Y
R432000090	Ø 3/8	Ø 3/8	2.44	0.83	1.03	0.75	0.67

# QR1-S-RVA standard series

- Angled plug-in connector
- pin bushing
- Ø 3/8
- push-in fitting
- Ø 3/8
- QR1-S-RVA



Working pressure min./max.	-13 ... 145 psi
Ambient temperature min./max.	32 ... 140 °F
Weight per piece	0.031 lbs

## Technical data

Part No.	Port G	Port D	Delivery unit
R432000191	Ø 3/8	Ø 3/8	10 piece

## Technical information

The series QR1 (plastic) and QR2 (metal) can not be combined

These pneumatic components with NPT or inch thread dimensions are only available from our US sales organization.

For further information about assembling and tolerances of adaptable tubing can be found in the "Technical information" document (available in the MediaCentre).

## Technical information

Material	
Material	nickel-plated
Housing	Polybutyleneterephthalate
Seal	Acrylonitrile butadiene rubber
Tooth lock washer	Stainless steel
Release ring	Polyoxymethylene
Release ring holder	Die cast zinc Brass, nickel-plated



## Dimensions

### Dimensions in inches

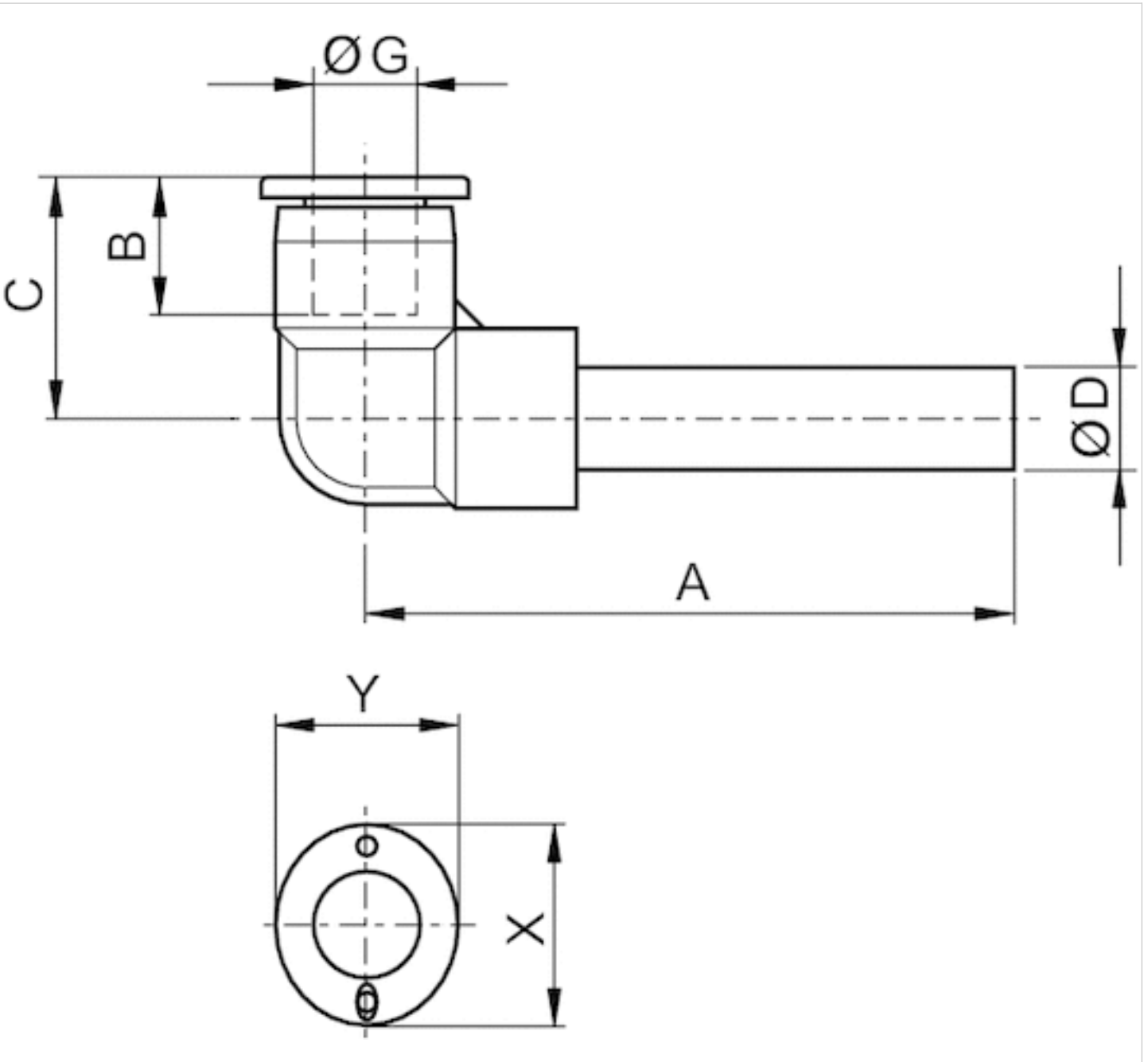

### Dimensions in inches

Part No.	Port D	Port G	A	B	C	X	Y
R432000191	Ø 3/8	Ø 3/8	1.85	0.83	1.03	0.75	0.67

# Check-choke valve, Series CC04

- $Q_n 1 \rightarrow 2 = 0.366 \text{ Cv}$
- direction of throttle  $1 \rightarrow 2$
- inlet-side throttling
- push-in fitting / pin bushing



Working pressure min./max.	8 ... 145 psi
Ambient temperature min./max.	14 ... 158 °F
Medium temperature min./max.	14 ... 158 °F
Medium	Compressed air

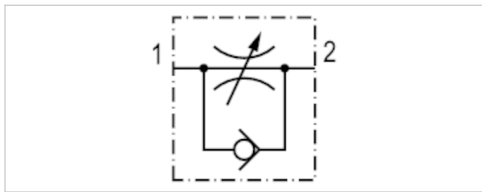

## Technical data

Part No.	Port 1	Port 2	Throttle bore	Flow
			Ø	$Q_n 1 \rightarrow 2$
R412007405	Ø 8	Ø 8	3.5 mm	0.366 Cv

Nominal flow  $Q_n$  at 87 psi and  $\Delta p = 14.5 \text{ psi}$

## Technical information

Material	
Housing	Polyamide
Flow control screw	Brass
Seals	Acrylonitrile butadiene rubber

Dimensions

Dimensions

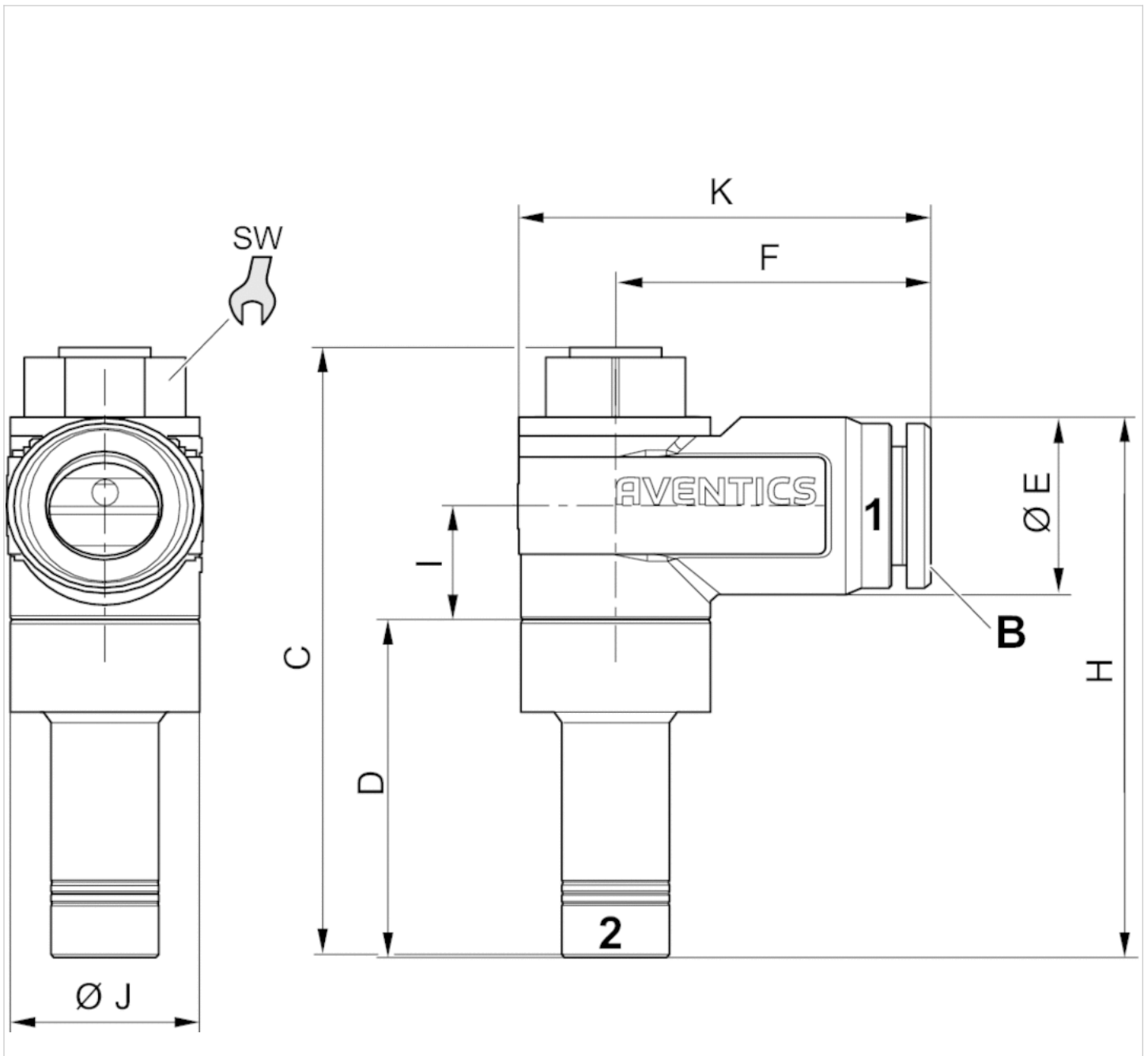

Dimensions

Part No.	Port 1	Port 2	C	D	ØE	F	H	I	ØJ	K	SW
R412007405	Ø 8	Ø 8	52,9	29,7	13,5	24,2	47,2	9,8	13,6	31,1	10

# Silencers, series SI1

- G 1/8 G 3/8
- Polyethylene



Working pressure min./max.	0 ... 145 psi
Ambient temperature min./max.	-13 ... 176 °F
Medium	Compressed air
Sound pressure level	See table below
Weight	See table below

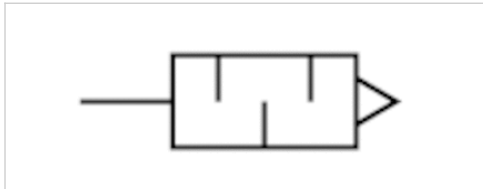

## Technical data

Part No.	Compressed air connection	Sound pressure level	Flow	Delivery unit	Weight
			Qn		
1827000019	G 1/8	78 dB	1.5 Cv	5 piece	0.004 lbs
1827000021	G 3/8	85 dB	5.3 Cv	2 piece	0.018 lbs

Weight per piece

Nominal flow Qn at p1 = 87 psi (absolute) freely discharged. Sound pressure level measured at 87 psi against atmosphere at 3.281 ft. distance.

## Technical information

Flow characteristic curves can be found under "Diagrams".

## Technical information

Material	
Silencer	Polyethylene
Thread	Polyethylene

## Dimensions

### Dimensions

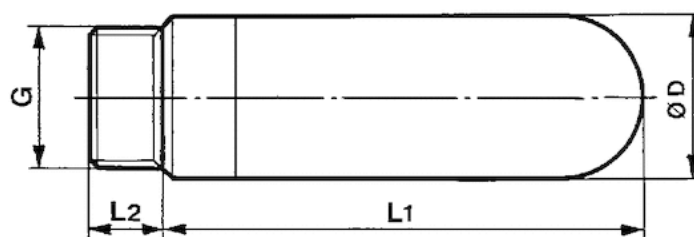

## Dimensions

Part No.	Port G	Ø D	L1	L2
1827000019	G 1/8	12.5	28.5	5.5
1827000021	G 3/8	18.5	56	11.5

## Diagrams

Flow diagram, 1827000018

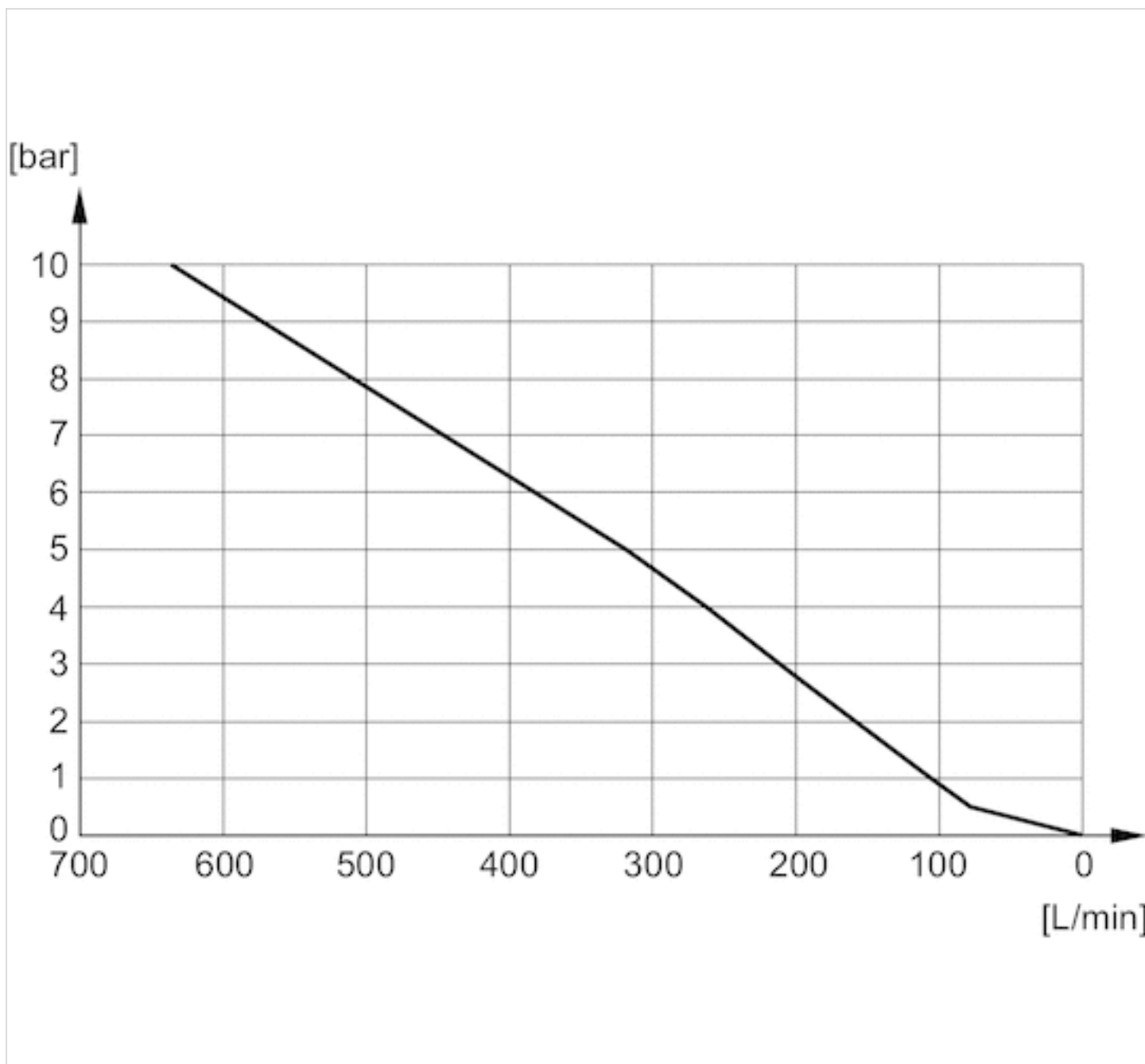

Flow diagram, 1827000019

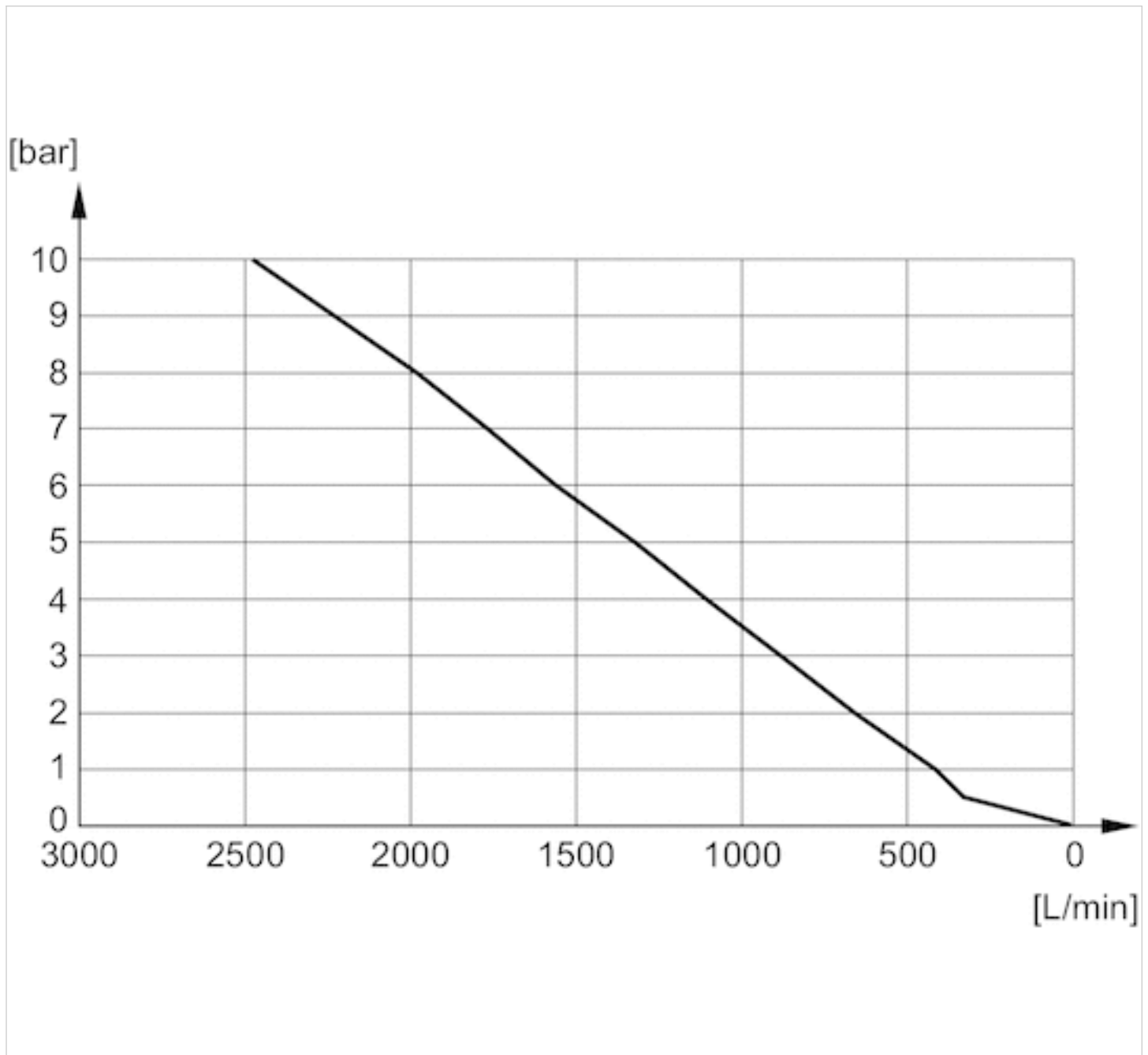

Flow diagram, 1827000020

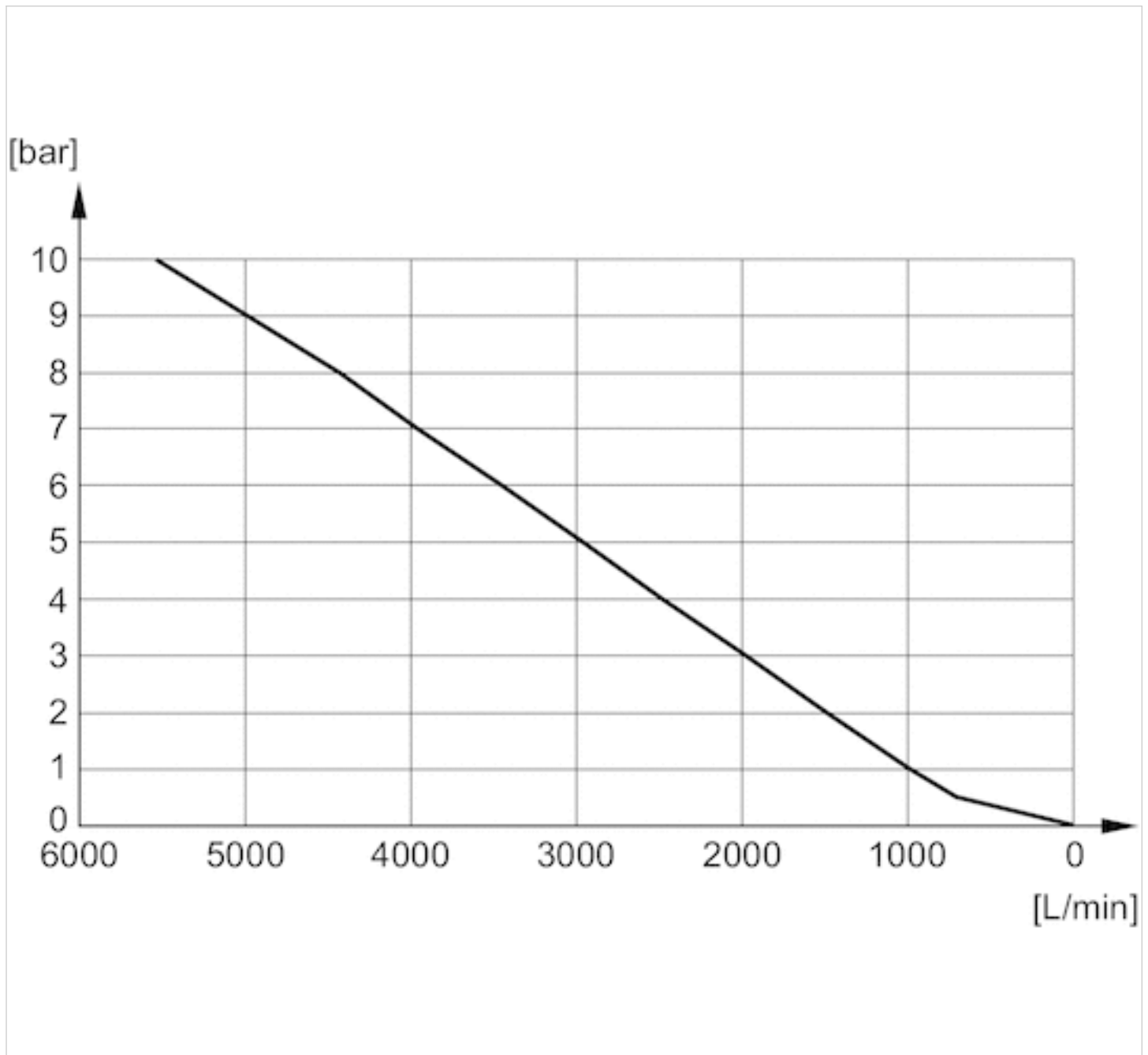



Flow diagram, 1827000021

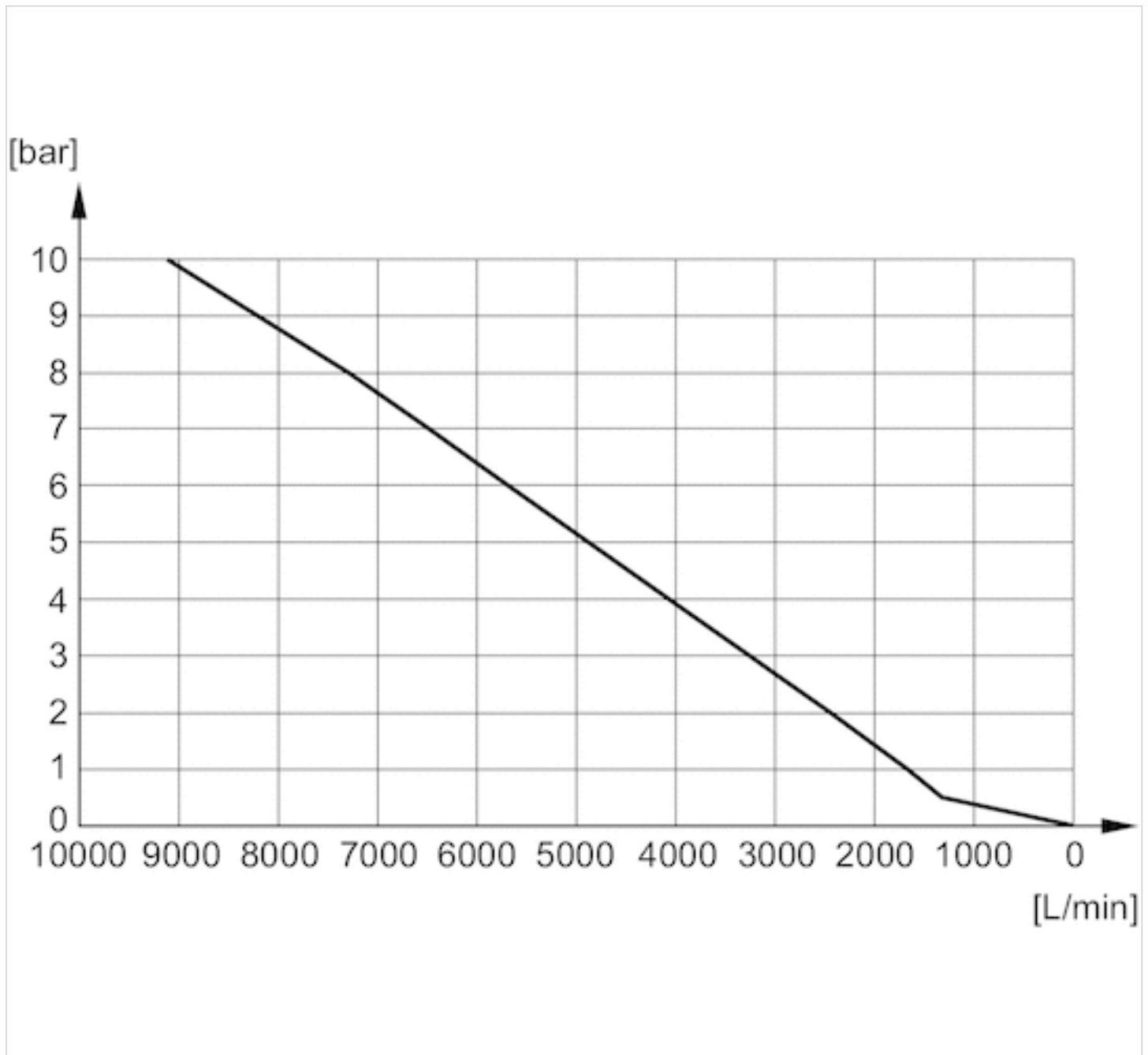

Flow diagram, 1827000022

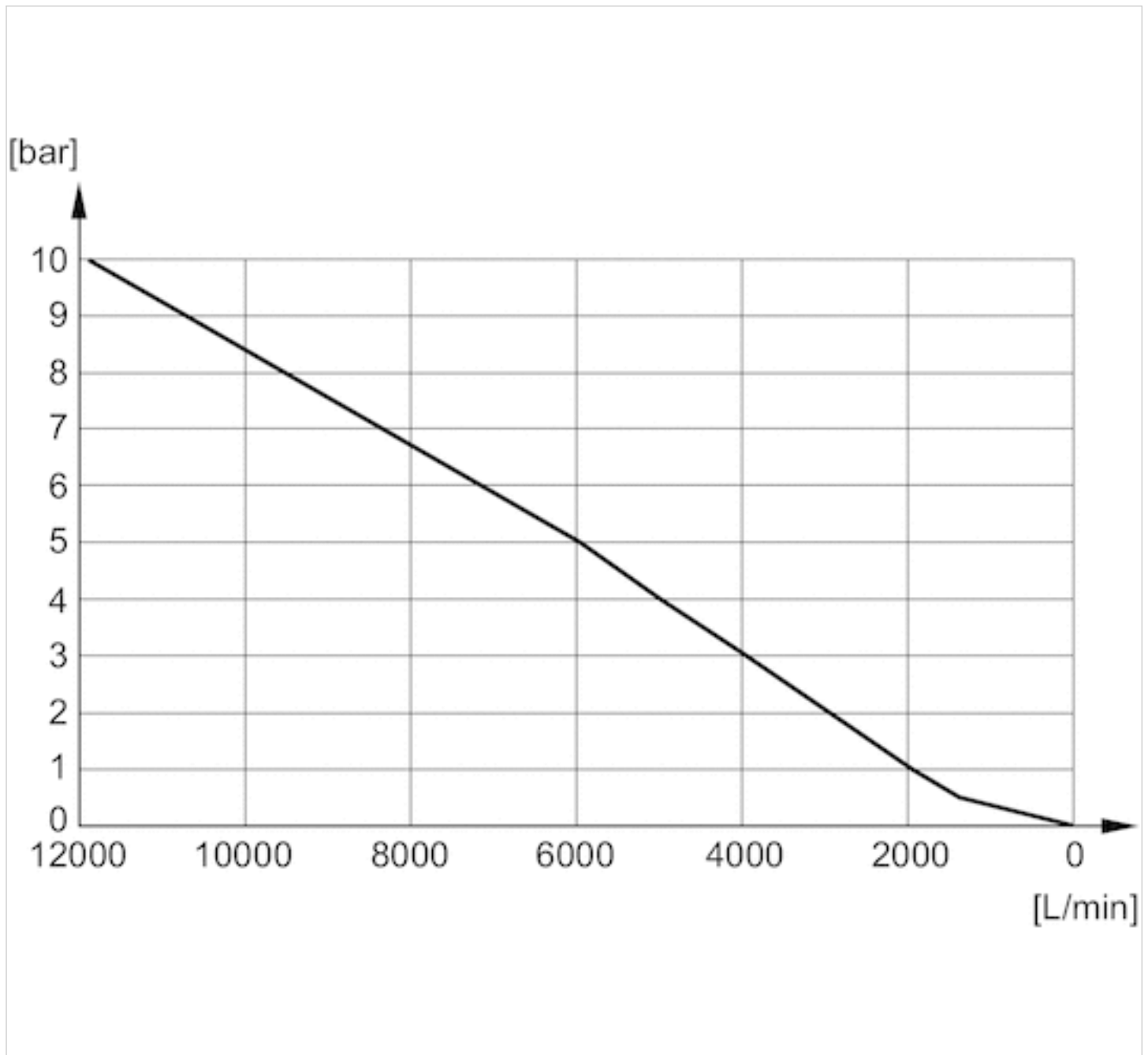

Flow diagram, 1827000023

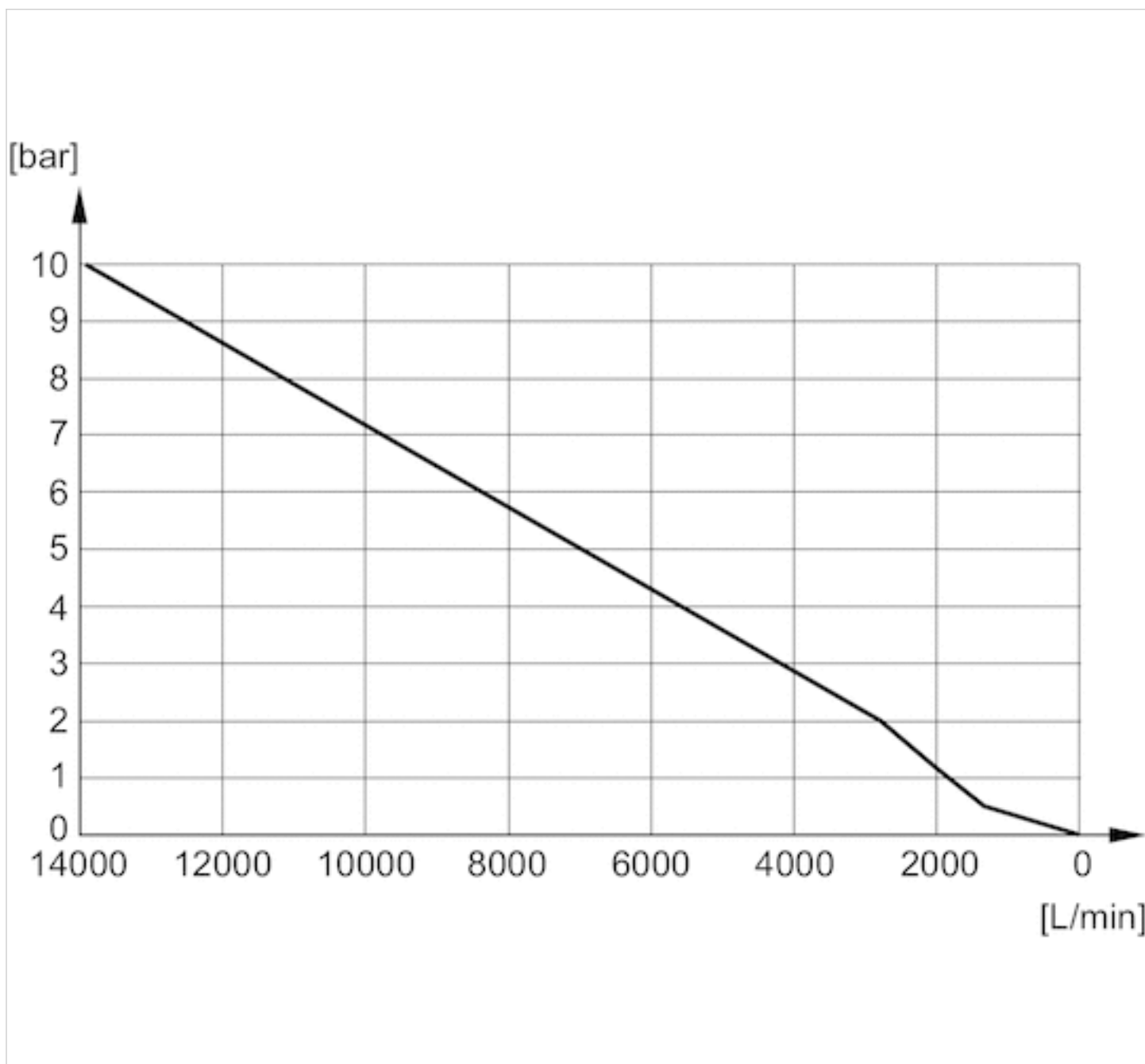

Flow diagram, 1827000024

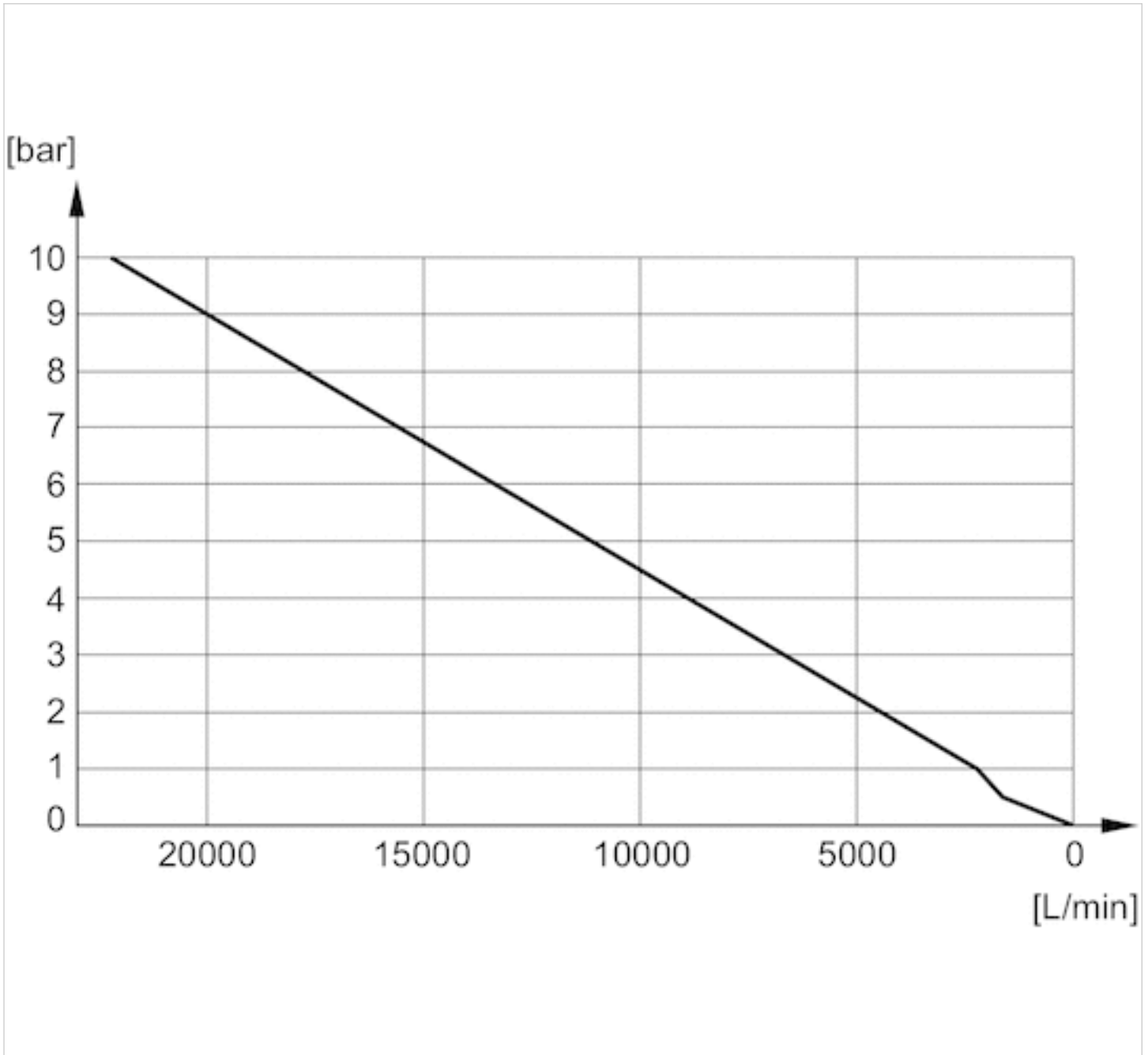

# Silencers, series SI1

- Ø 8

- Polyethylene

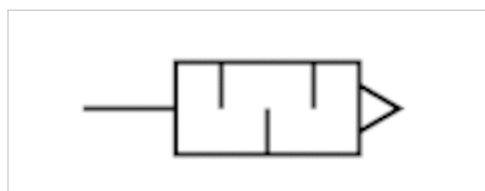

Working pressure min./max.	0 ... 145 psi
Ambient temperature min./max.	-13 ... 176 °F
Medium	Compressed air
Sound pressure level	90 dB
Weight	0.004 lbs
Comment	Flow characteristic curves can be found under "Diagrams".

## Technical data

Part No.	Compressed air connection	Flow	Delivery unit
		Qn	
R412007520	Ø 8	1.19 Cv	5 piece

Weight per piece

Nominal flow Qn at p1 = 87 psi (absolute) freely discharged. Sound pressure level measured at 87 psi against atmosphere at 3.281 ft. distance.

## Technical information

Material	
Silencer	Polyethylene
Thread	Polyethylene

## Dimensions

### Dimensions

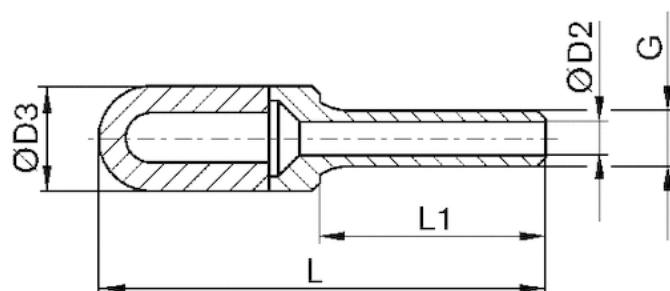

## Dimensions

Part No.	Port G	Ø D2	Ø D3	L1	L
R412007520	Ø 8	4.8	13.5	21.5	43.5

# Diagrams

## Flow diagram, R412007519

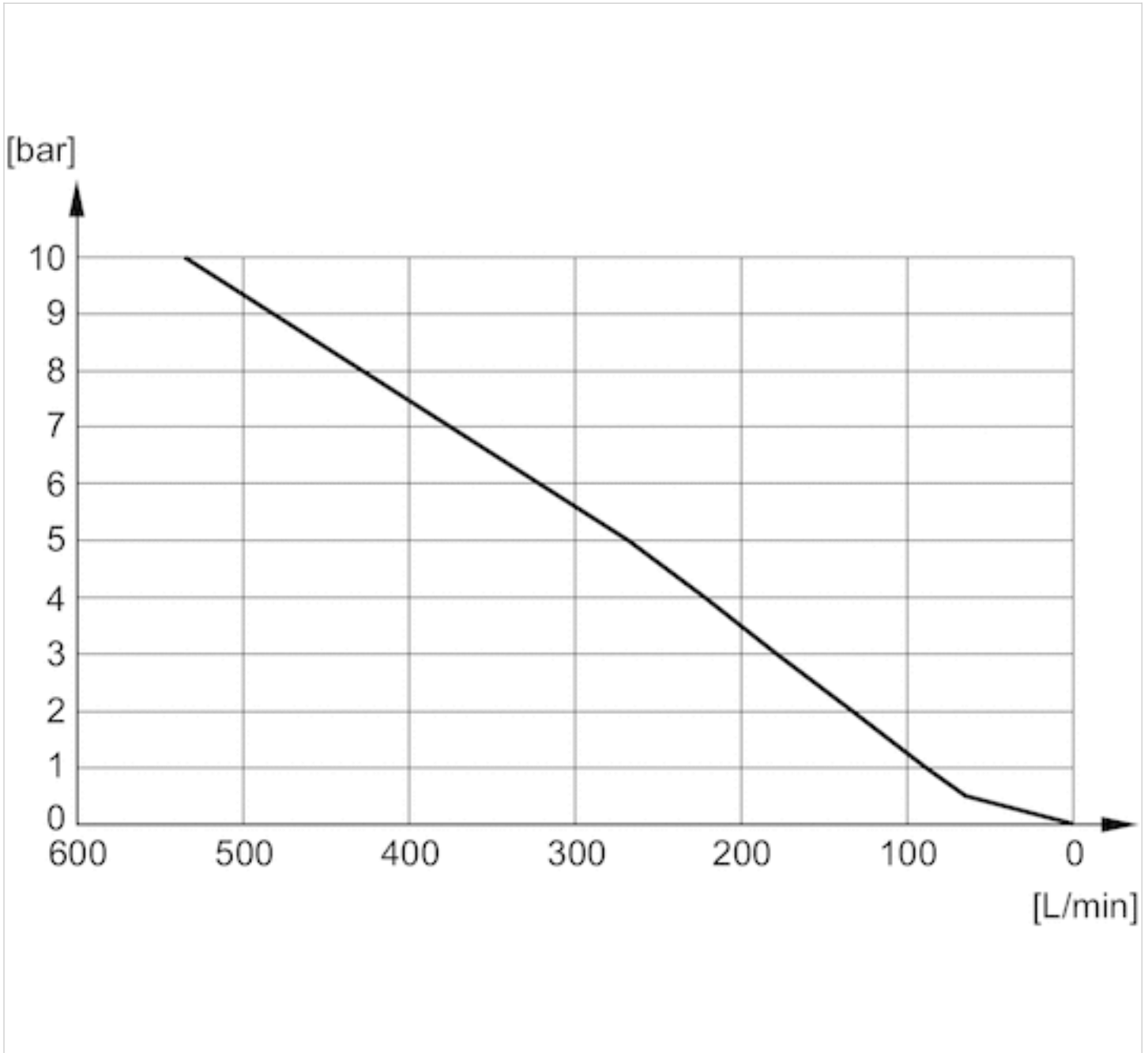

Flow diagram, R412007899

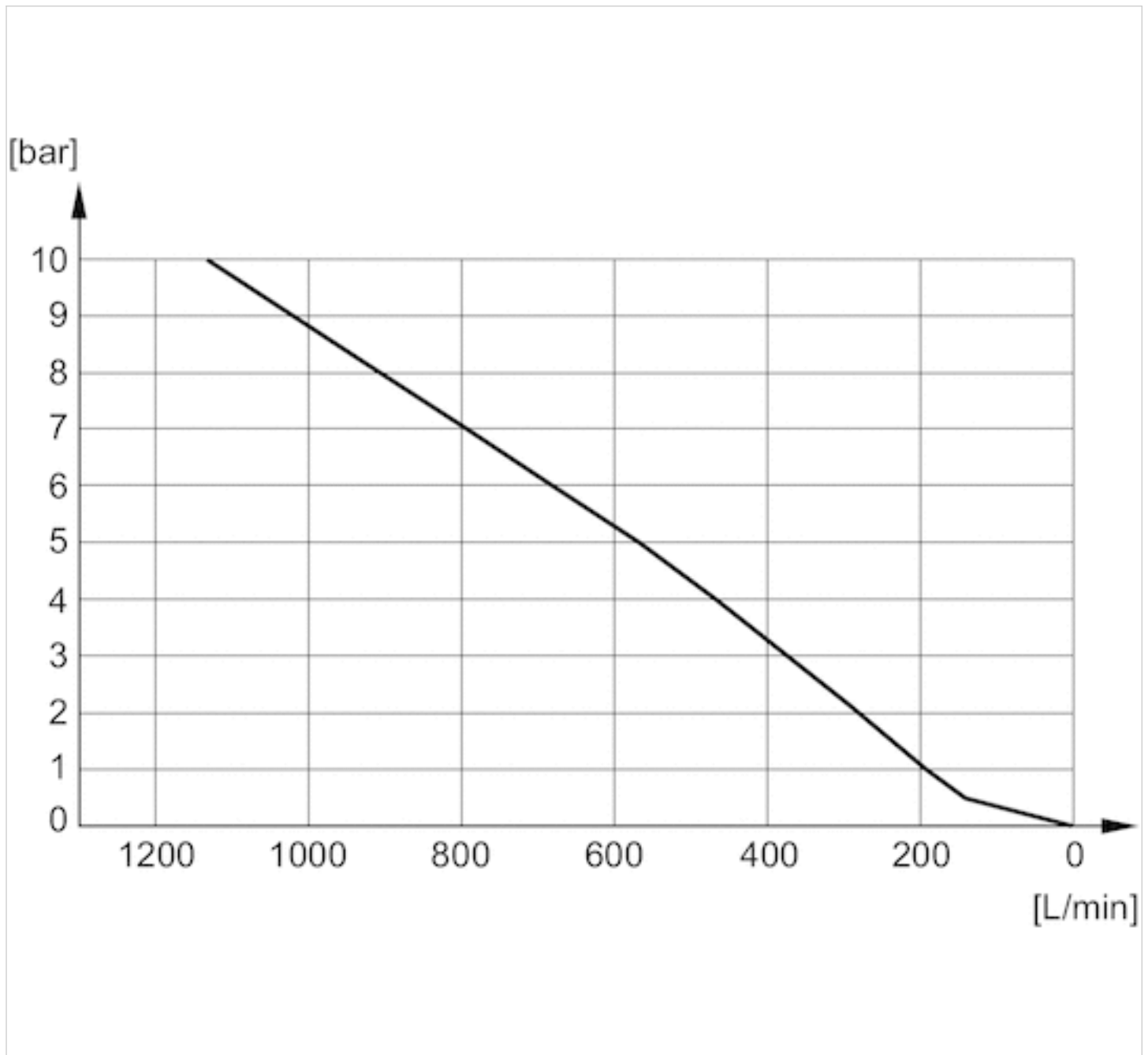



Flow diagram, R412000591

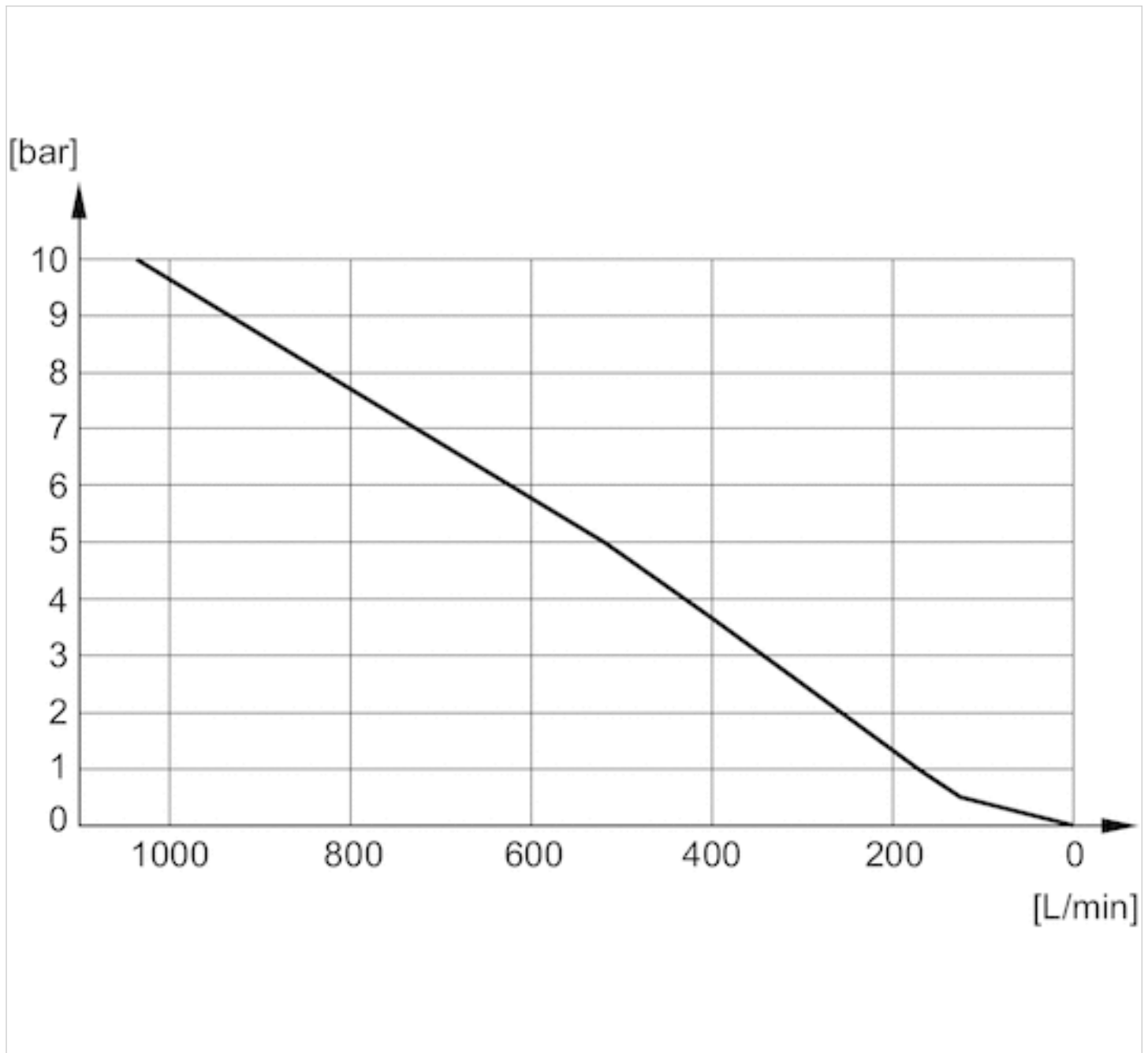

Flow diagram, R412007520

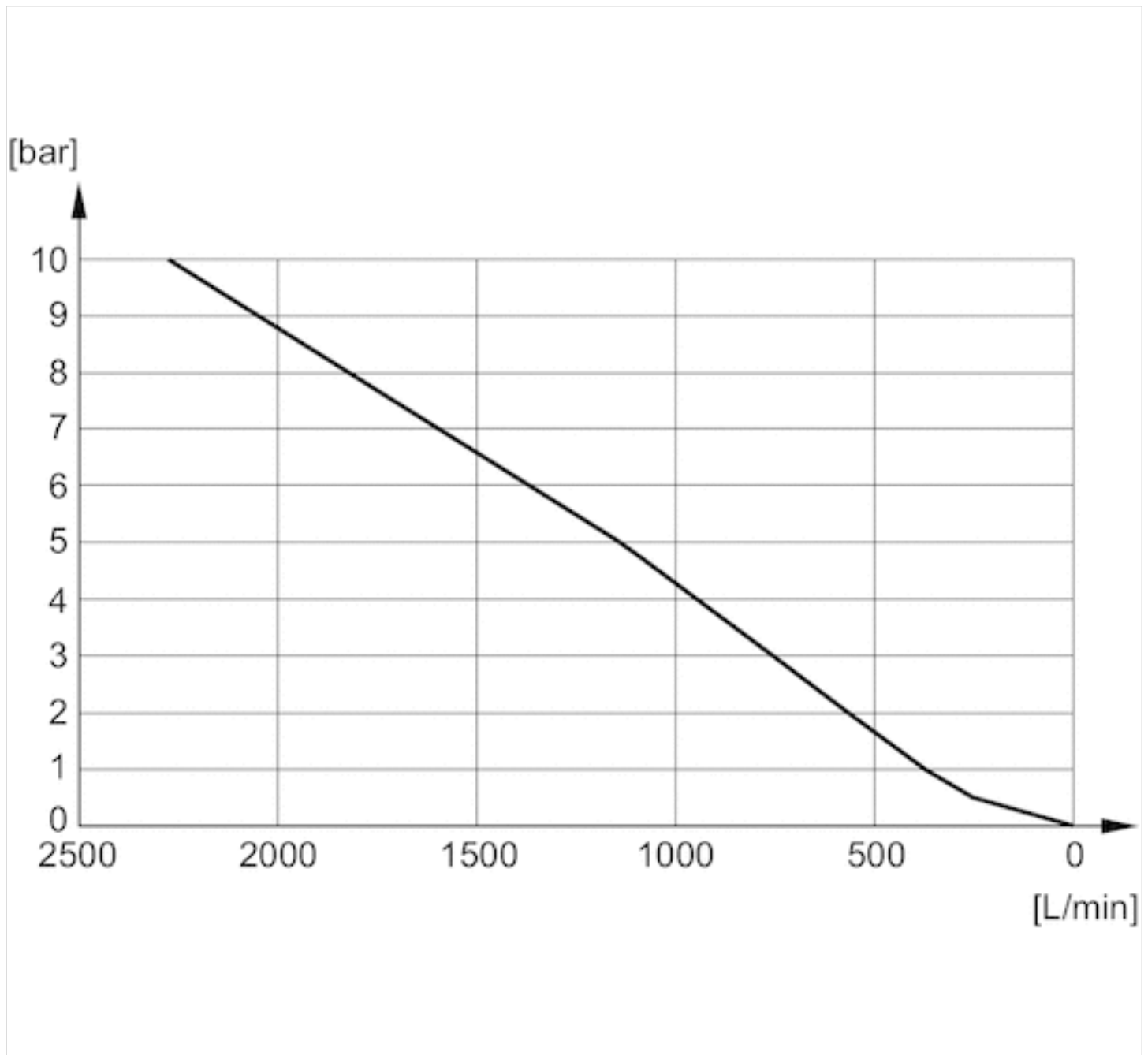

Flow diagram, R412000593

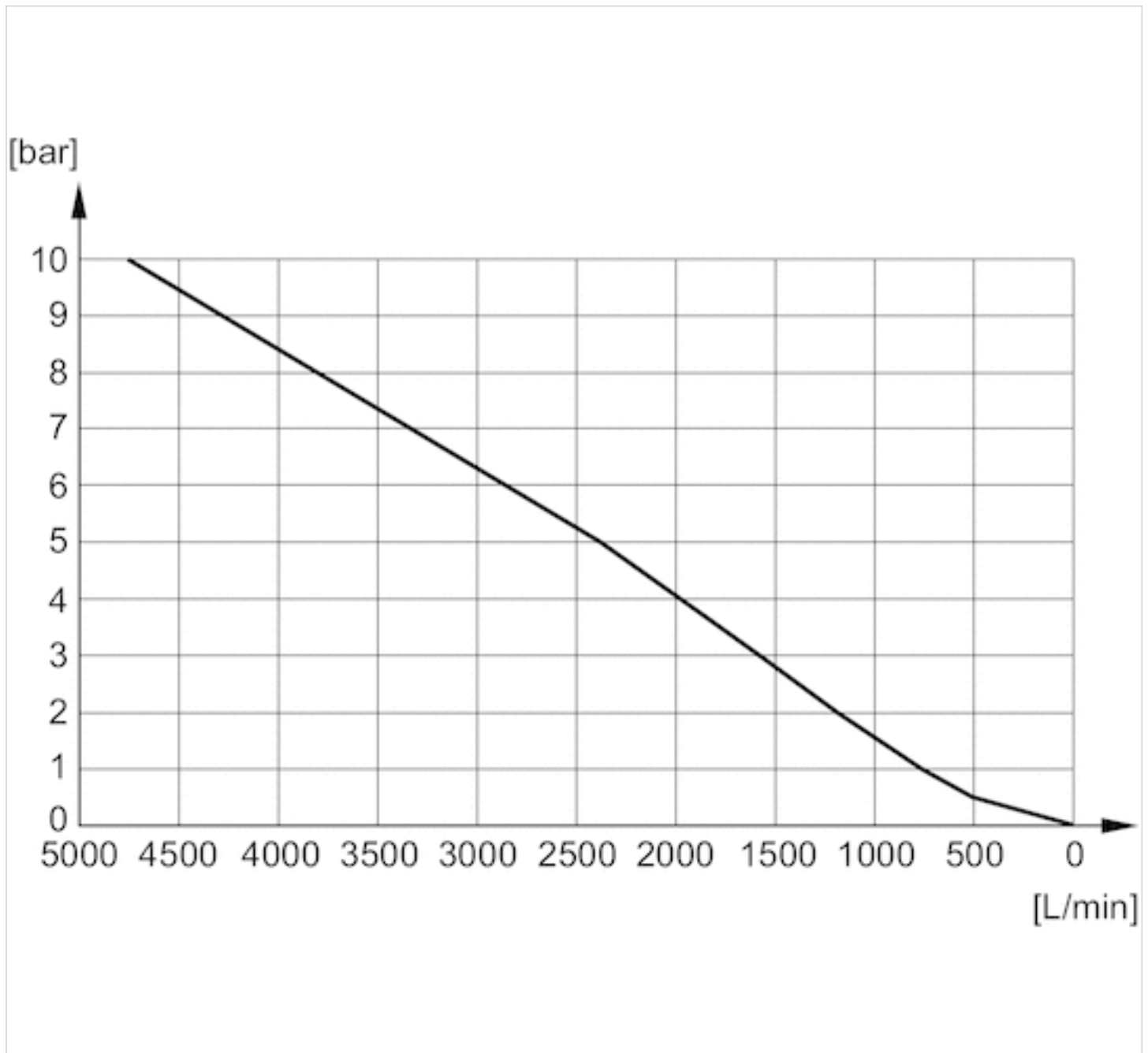

Flow diagram, R412007715

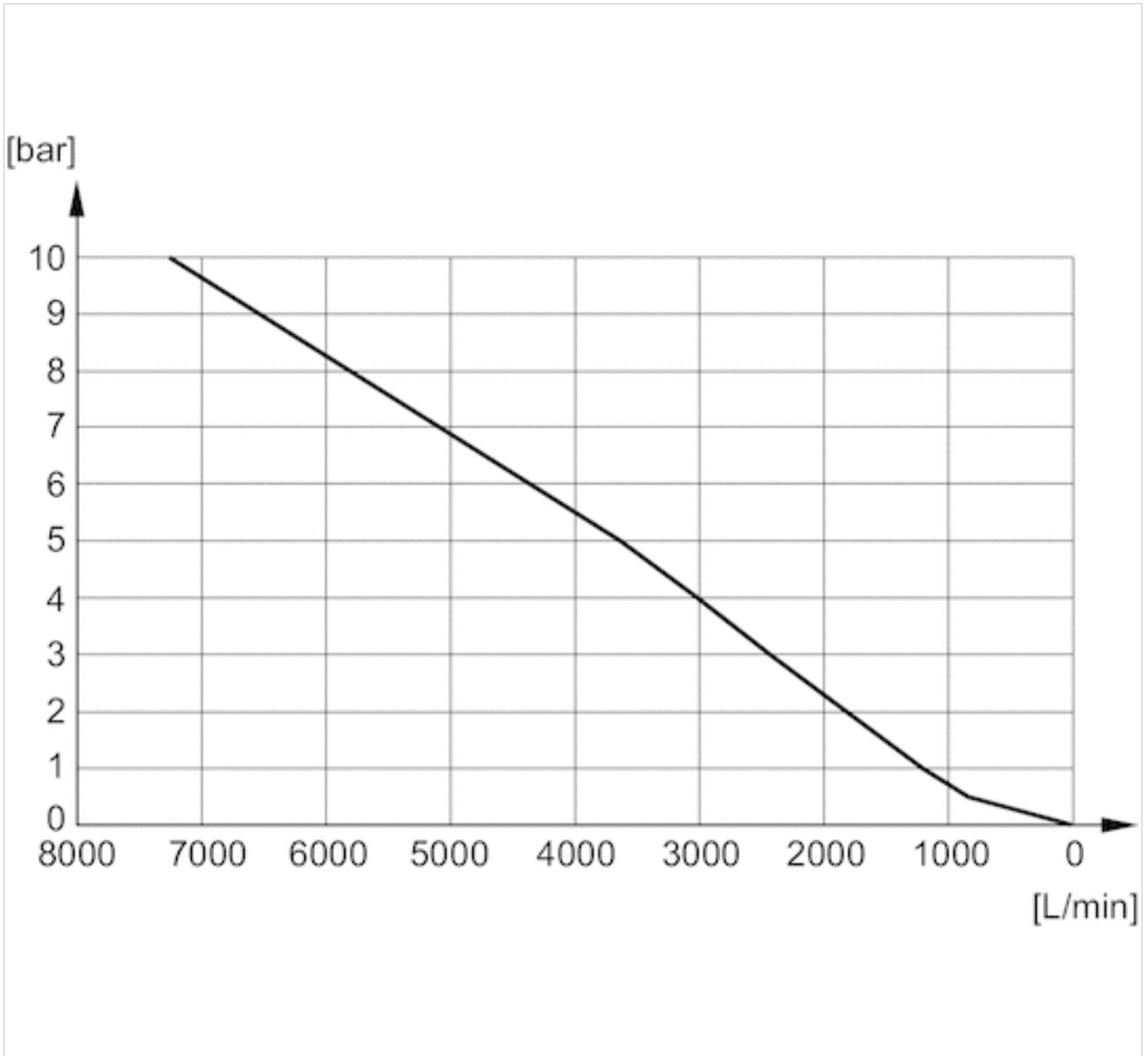

# Tie rod extension kit

- for ES05



Weight

See table below

## Technical data

Part No.	Type	Delivery unit	Weight
R422102761	Tie rod extension for 2 valve positions	1 piece	0.055 lbs
R422P02761	Tie rod extension for 2 valve positions	5 piece	0.055 lbs
R422102760	Tie rod extension for 4 valve positions	1 piece	0.11 lbs
R422P02760	Tie rod extension for 4 valve positions	5 piece	0.11 lbs
R422102772	Tie rod extension for 6 valve positions	1 piece	0.165 lbs
R422P02772	Tie rod extension for 6 valve positions	5 piece	0.165 lbs

Scope of delivery: 2 tie rod extensions

## Technical information

An example configuration is illustrated. The delivered product may thus deviate from the illustration.

## Technical information

Material	
Housing	Aluminum
Screws	Steel

## Dimensions

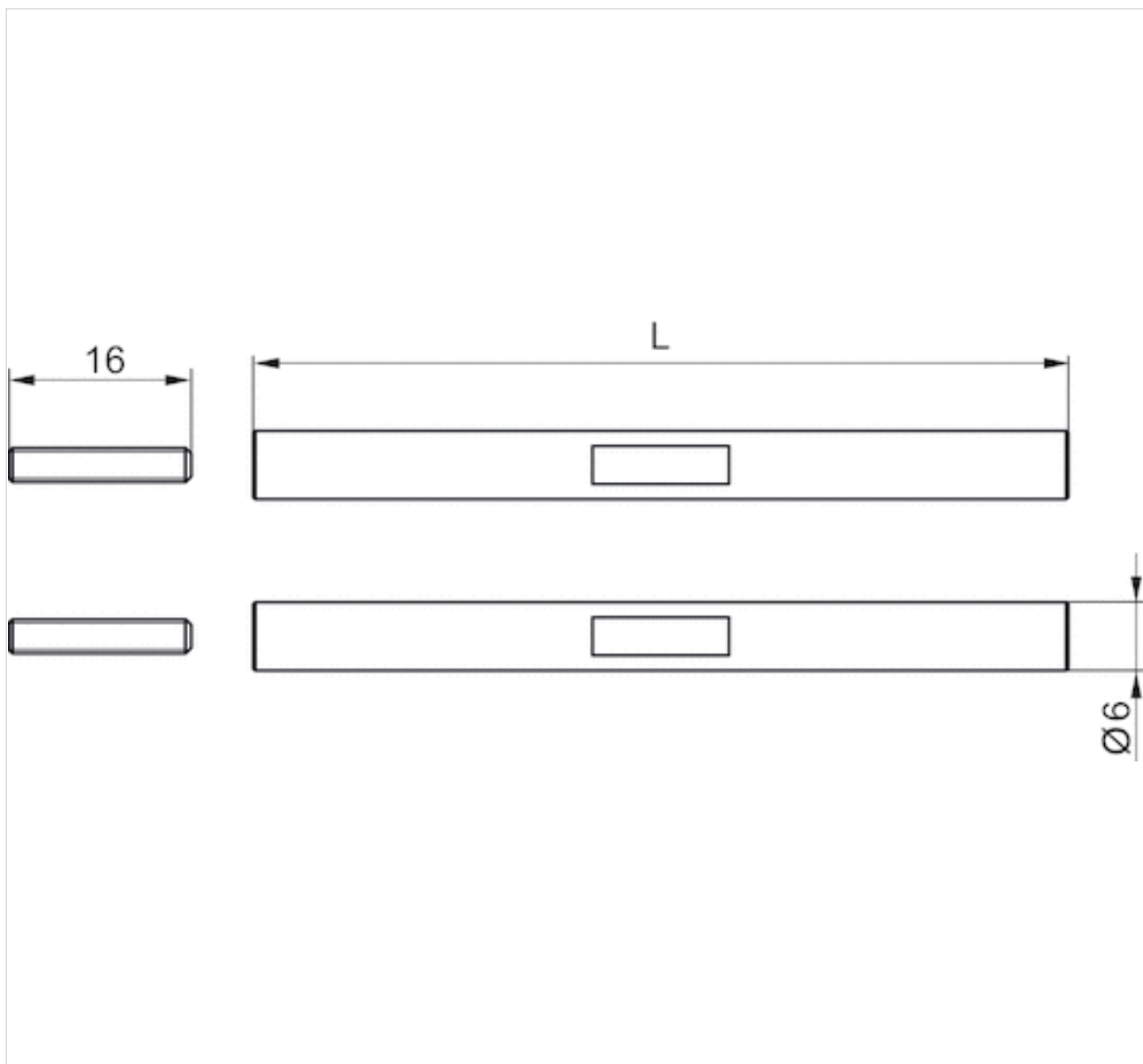

## Dimensions

Part No.	L
R422102761	36
R422P02761	36
R422102760	72
R422P02760	72
R422102772	108
R422P02772	108

L = length

# Mounting kit for DIN rail

- for AV03, AV05, AES, ES05

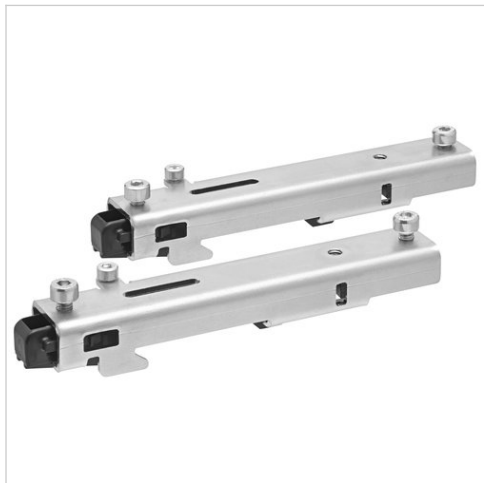

## Technical data

Part No.
R412019468

Scope of delivery: 2 clamps, 4 screws M4x8 DIN 912, 1 screw M3x14 DIN 912, Note: The valve system should not be equipped with more than the maximum number of components. After maximum equipment of the valve system, we recommend no longer assembling the valve system on a DIN rail.

## Technical information

Material	
Housing	Steel, chrome-plated



## Dimensions

### Dimensions

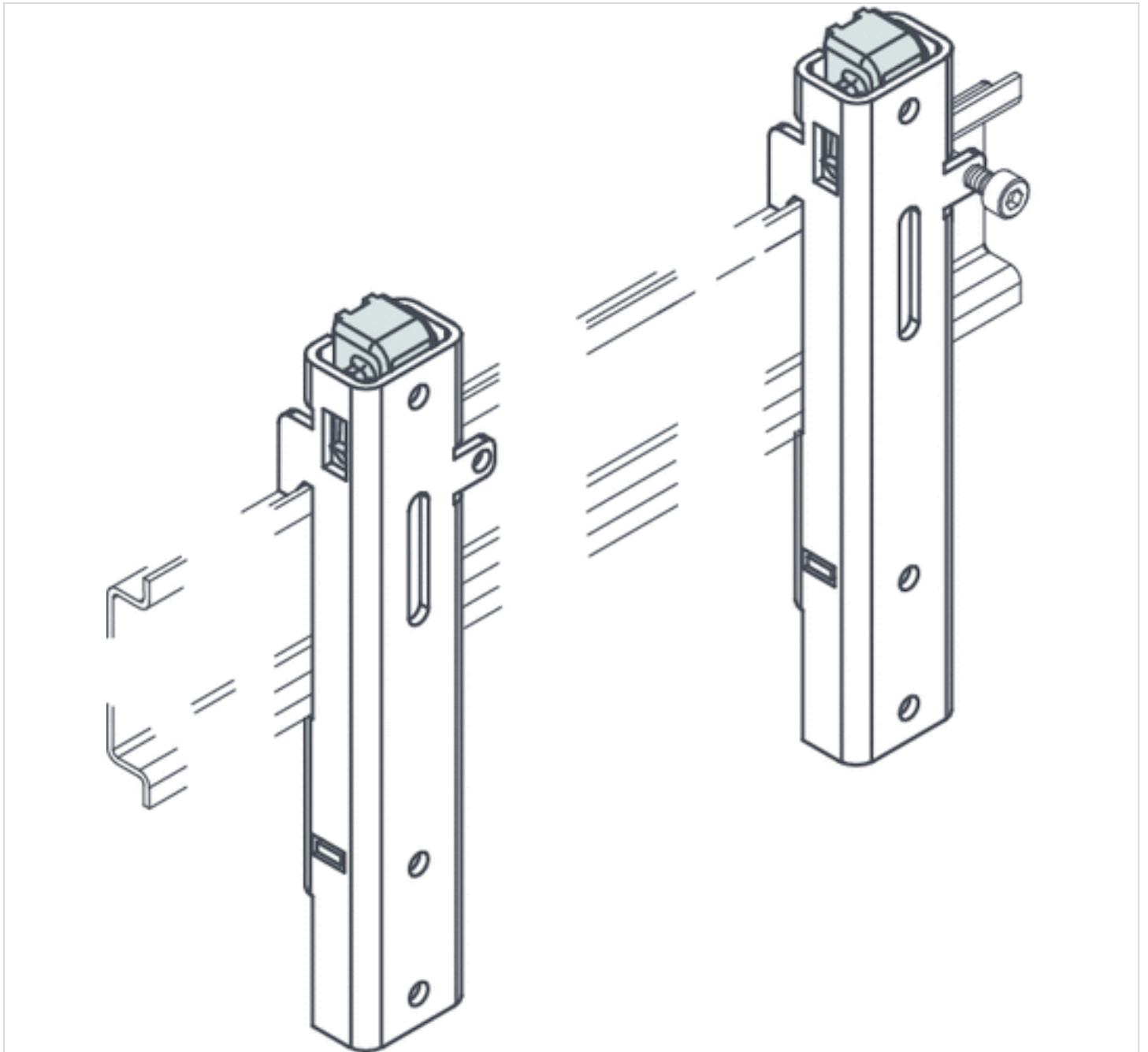

# Valve plug connector, series CON-VP

- Socket, 2+E, angled, 90° Socket, form C, industry, 2+E, angled, 90°
- Industry standard
- unshielded
- with LED Yellow



Connection type	Screws
Ambient temperature min./max.	-4 ... 176 °F
Operational voltage	See table below
Protection class	IP65
Mounting screw tightening torque	0.3 ft./lbs.
Weight	See table below

## Technical data

Part No.	Electrical connection
1834484050	Socket 2+E angled 90°
4402030330	Socket form C, industry 2+E angled 90°

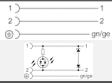

Part No.	Operational voltage	Max. current	Protective circuit	Contact assignment	LED status display
1834484050	-	6 A	-	2+E	-
4402030330	24 V AC/DC	6 A	Z-diode	2+E	Yellow

Part No.	Seal	Weight	Fig.	
1834484050	caoutchouc/butadiene caoutchouc	0.264 lbs	Fig. 1	1)
4402030330	-	0.026 lbs	Fig. 2	-

1) Scope of delivery incl. flat gasket

## Technical information

The specified protection class is only valid in assembled and tested state.

## Technical information

Material	
Seals	caoutchouc/butadiene caoutchouc

## Dimensions

Fig. 1

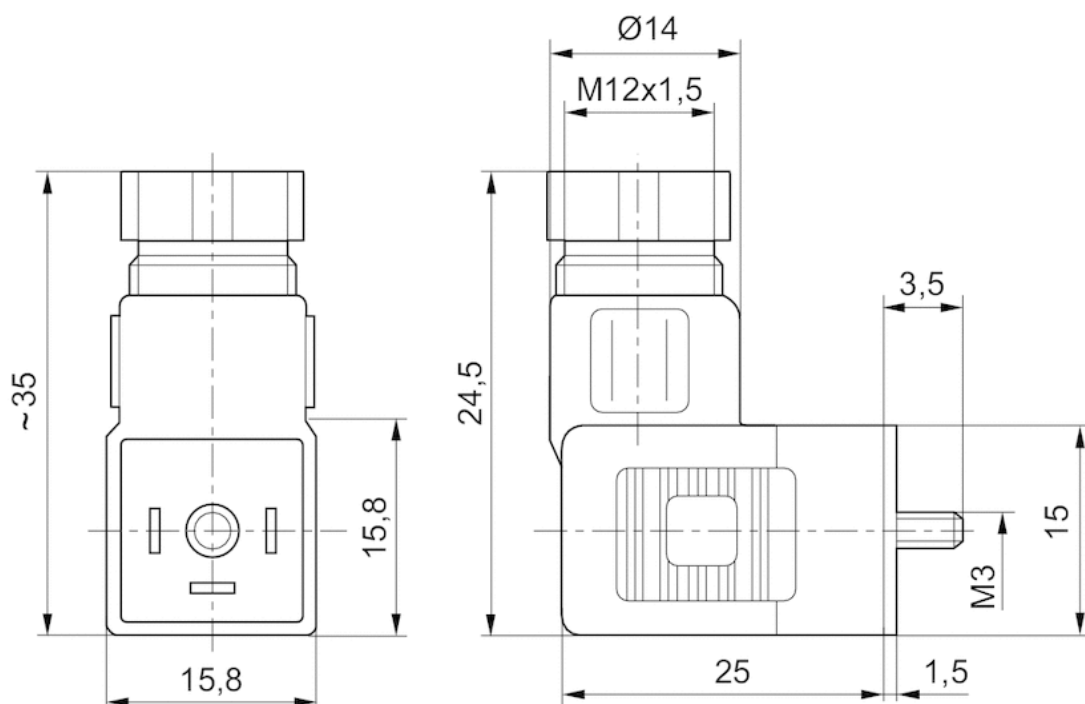
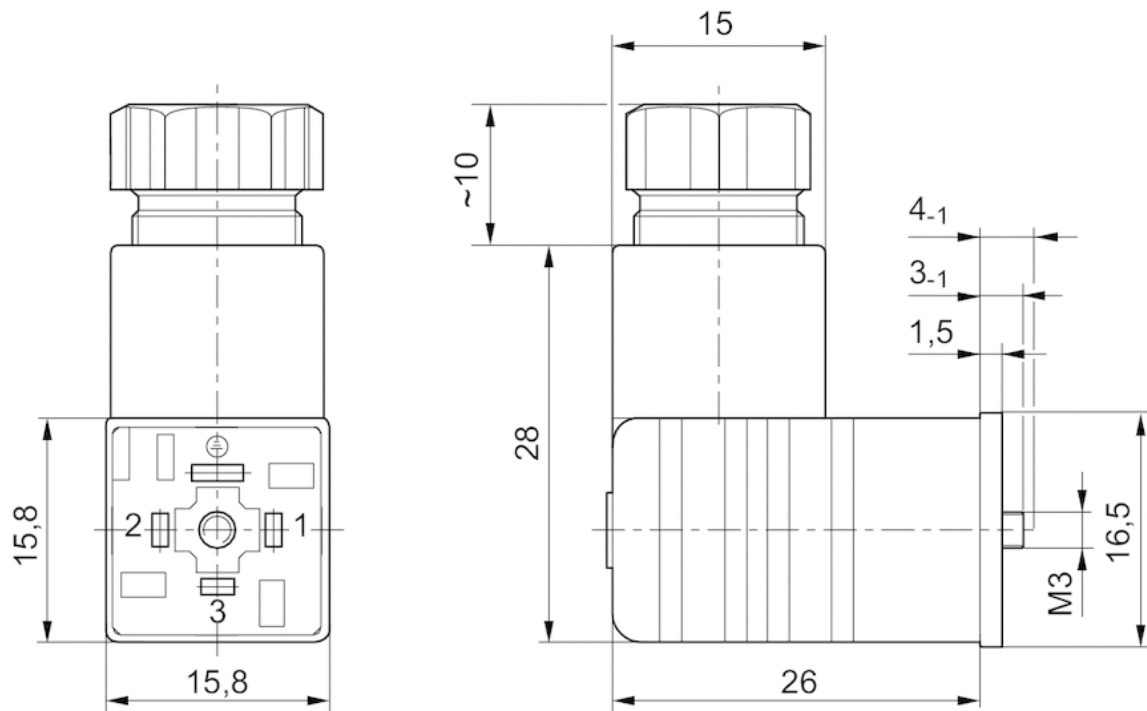

Fig. 2



# Valve plug connector, series CON-VP

- Socket form C, industry 4-pin angled 90°
- open cable ends 3-pin
- with cable
- unshielded



Ambient temperature min./max.	-13 ... 194 °F
Operational voltage	24 V AC/DC
Protection class	IP65
Protective circuit	Varistor
Wire cross-section	0.001 in <sup>2</sup>
Mounting screw tightening torque	0.295 ft./lbs.
Weight	0.264 lbs

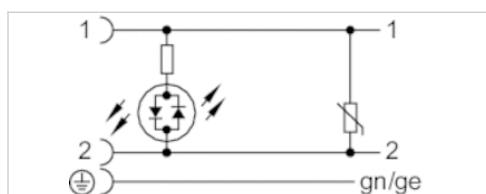

## Technical data

Part No.	Max. current	Contact assignment	LED status display	Number of wires
R412024833	1.5 A	2+E	Yellow	3
R412024834	1.5 A	2+E	Yellow	3
R412024835	1.5 A	2+E	Yellow	3

## Technical information

Material	
Housing	Polyamide
Seals	caoutchouc/butadiene caoutchouc
Cable sheath	Polyvinyl chloride

## Dimensions

### Dimensions

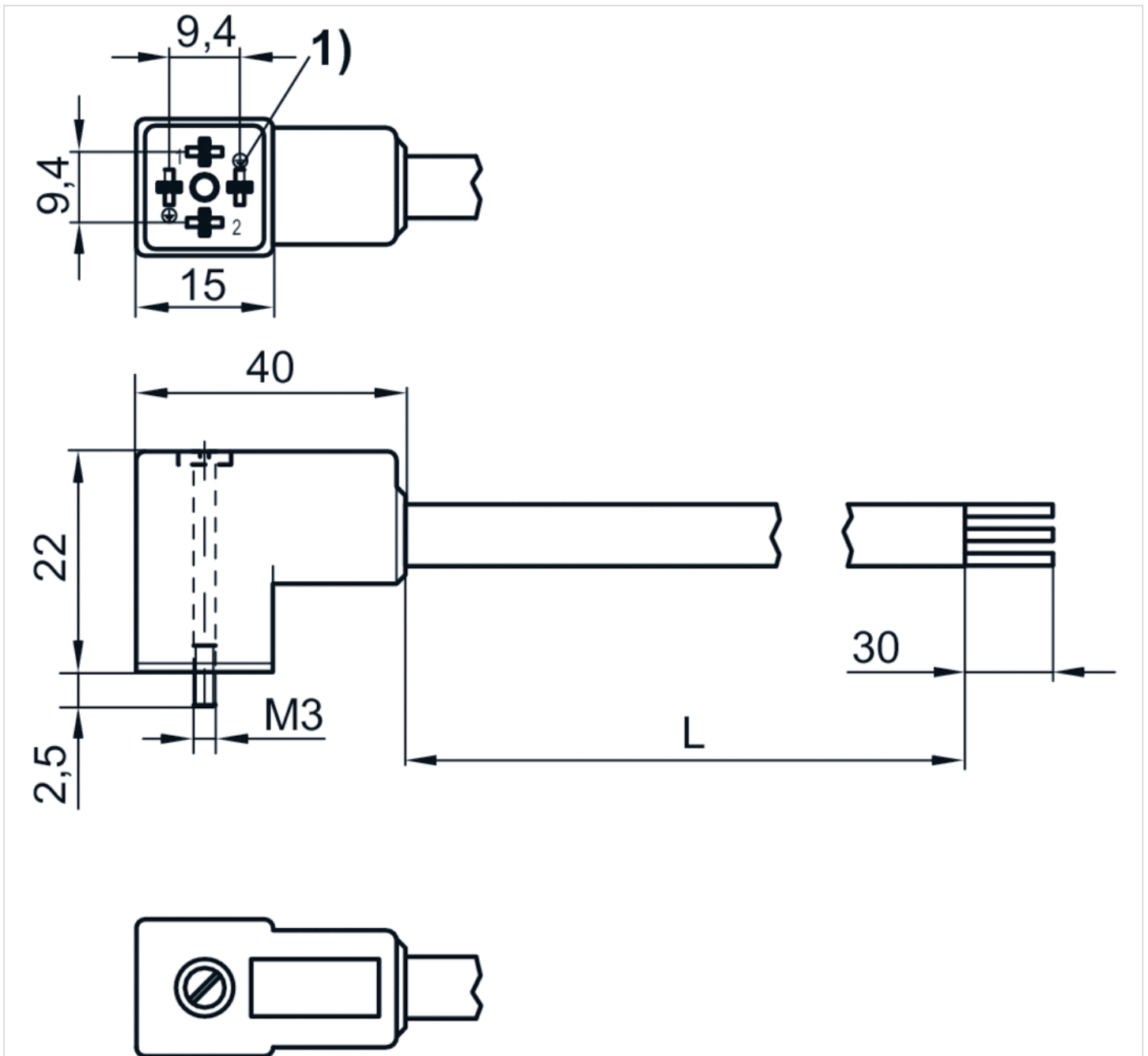

1) Coding pin  
L = length

# Round plug connector, Series CON-RD

- Socket M8x1 3-pin A-coded straight 180°
- open cable ends
- with cable
- UL (Underwriters Laboratories)
- unshielded



Ambient temperature min./max.	-13 ... 185 °F
Operational voltage	48 V AC/DC
Protection class	IP67
Wire cross-section	0 in <sup>2</sup>
Weight	See table below

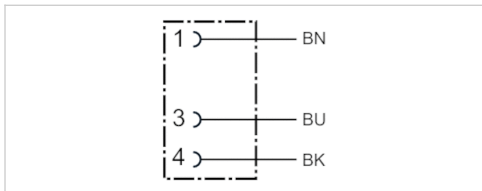

## Technical data

Part No.	Max. current	Number of wires	Cable-Ø	Cable length	Certification	Weight
1834484166	4 A	3	0.18 inch	9.84 ft.	UL (Underwriters Laboratories)	0.201 lbs
1834484168	4 A	3	0.18 inch	16.4 ft.	UL (Underwriters Laboratories)	0.32 lbs
1834484247	4 A	3	0.18 inch	32.81 ft.	UL (Underwriters Laboratories)	0.728 lbs

## Technical information

The specified protection class is only valid in assembled and tested state.

## Technical information

Material	
Housing	Polyurethane
Cable sheath	Polyurethane

## Dimensions

## Dimensions

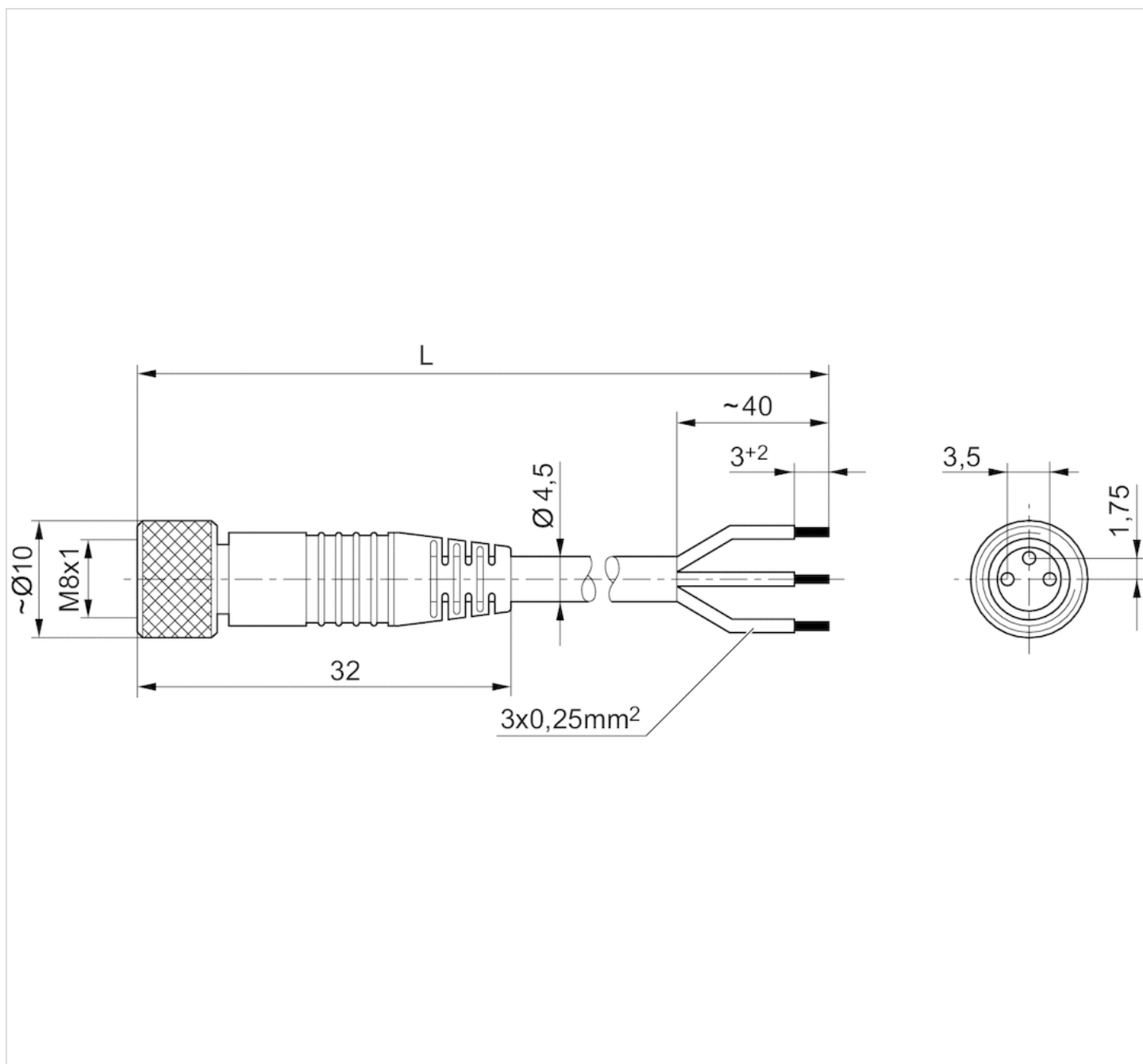

L = length



## Pin assignments

### Pin assignment, socket

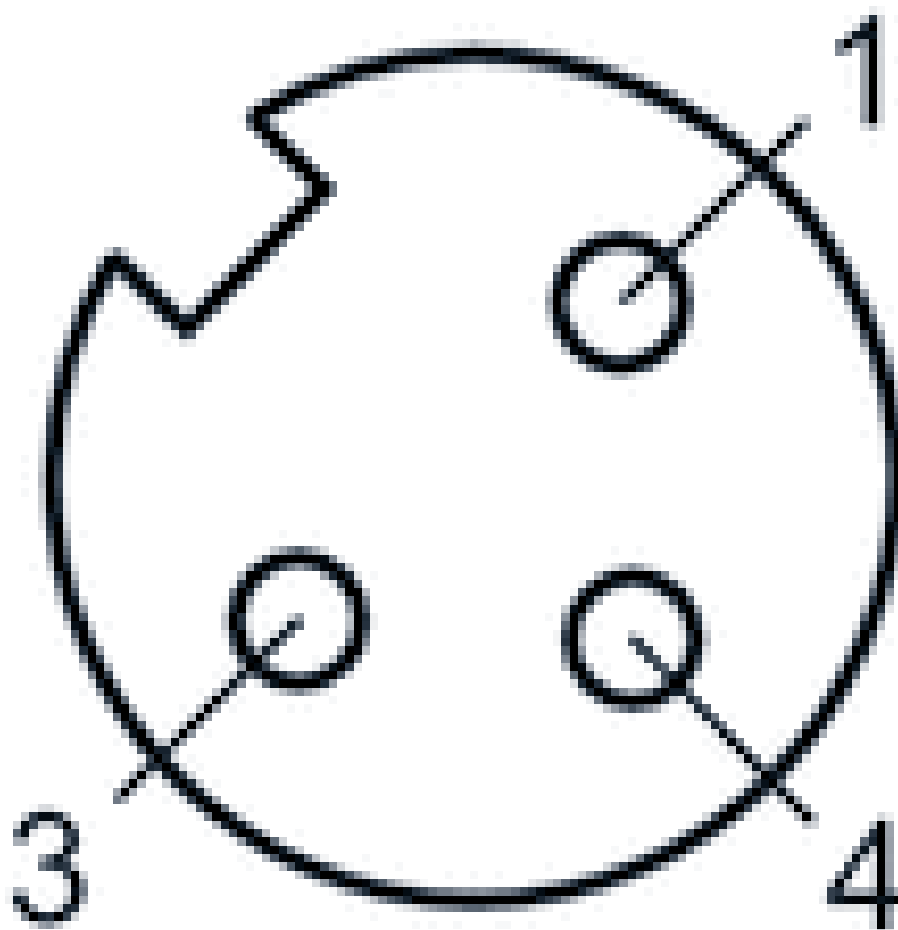

- (1) BN=brown
- (3) BU=blue
- (4) BK=black

# Multipole plug, series CON-MP

- Socket, D-Sub, 25-pin, Angled/straight, 90°/180° Plug, D-Sub, 25-pin, Angled/straight, 90°/180°
- unshielded



Connection type	Soldering/crimping
Ambient temperature min./max.	23 ... 122 °F
Operational voltage	24 V DC
Protection class	IP65
Weight	0.092 lbs

## Technical data

Part No.	Electrical connection	Max. current	suitable cable-Ø min./max
	1		
R412011240	Socket D-Sub 25-pin Angled/straight 90°/180°	3 A	0.16 / 0.51 inch
R412011241	Plug D-Sub 25-pin Angled/straight 90°/180°	3 A	0.16 / 0.51 inch

Scope of delivery: multipole plug including 1 tube nut and 1 elbow fitting

## Technical information

The specified protection class is only valid in assembled and tested state.  
 Note for use with VS LP04: The plug can only be used in the LP04 versions with a side electrical connection.

## Technical information

Material	
Housing	Polyamide

## Dimensions

### Dimensions

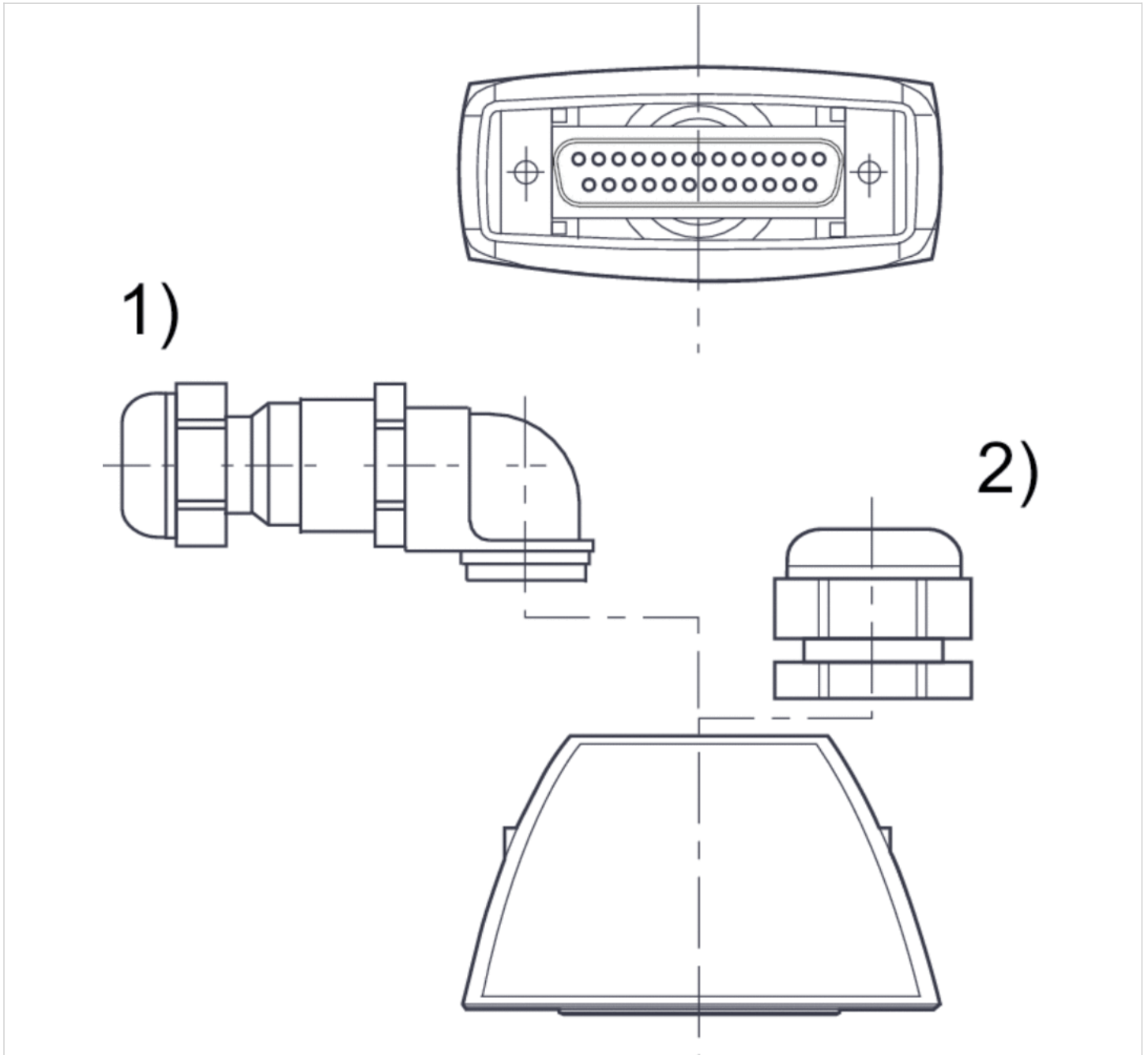

- 1) Elbow fitting
- 2) tube nut

Dimensions

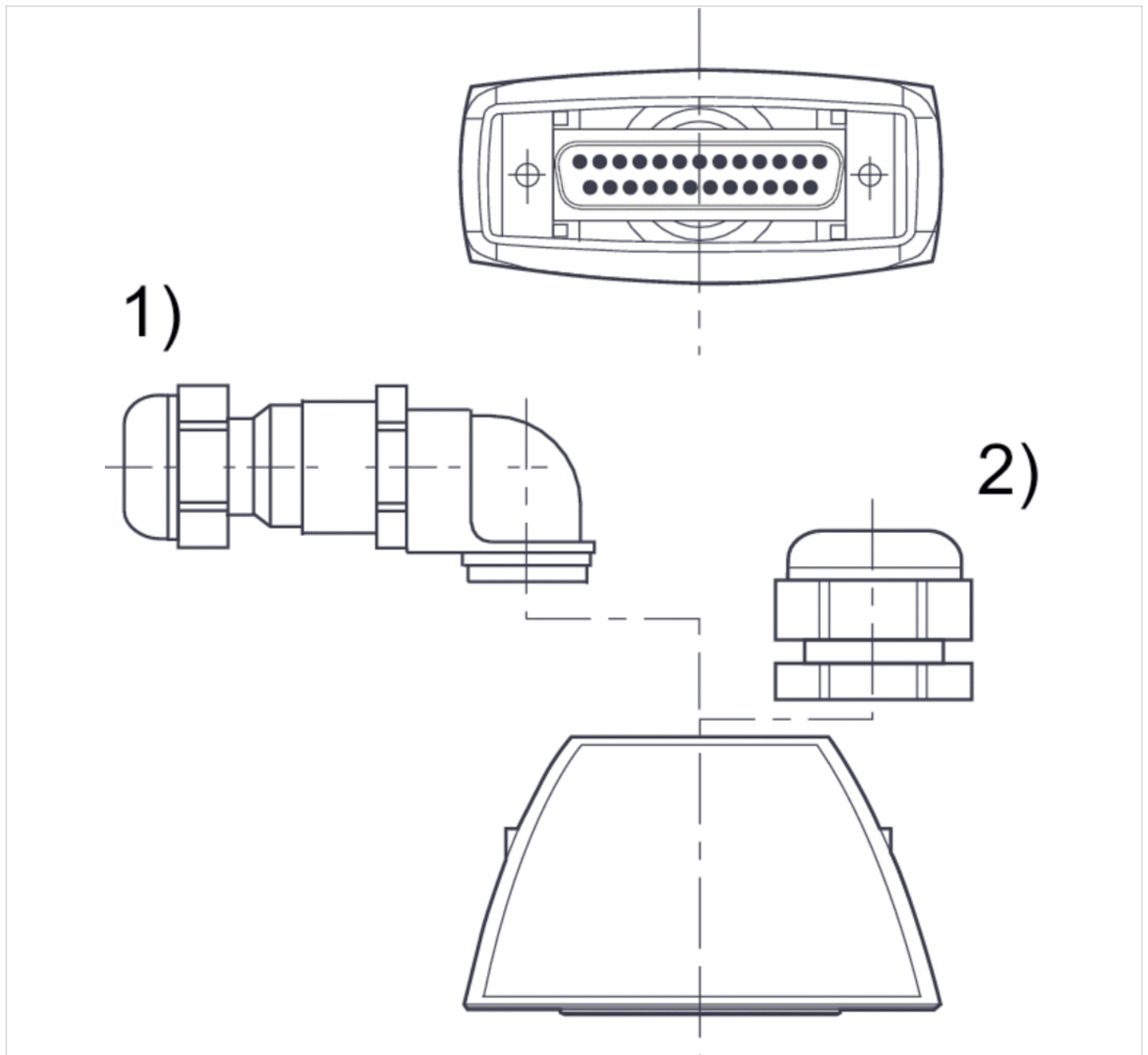

- 1) Socket
- 2) tube nut

## Pin assignments

PIN assignment and cable colors, cable identification as per DIN 47100

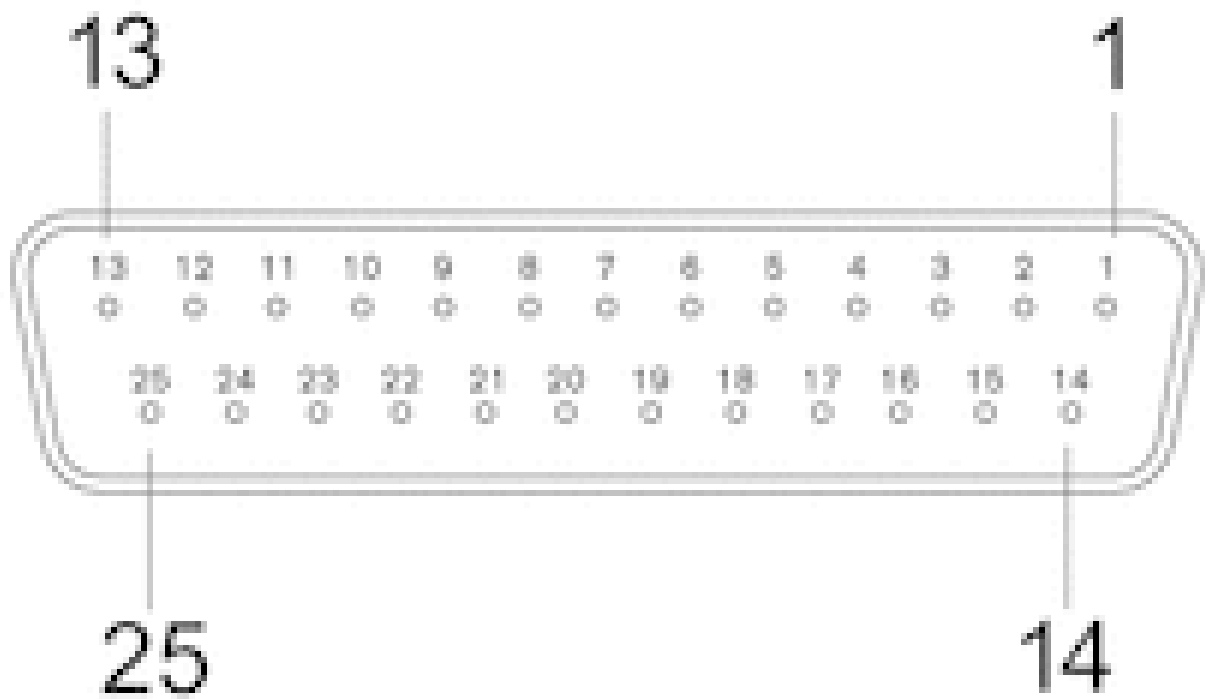

Socket

# Multipole plug, series CON-MP

- open cable ends 25-pin
- with cable
- unshielded



Ambient temperature min./max.	-4 ... 176 °F
Operational voltage	24 V DC
Protection class	IP67
Wire cross-section	0 in <sup>2</sup>

## Technical data

Part No.	Electrical connection	Max. current	Number of wires	Cable sheath
	1			
R419500454	Socket D-Sub 25-pin straight 180°	3 A	25	Polyvinyl chloride
R419500455	Socket D-Sub 25-pin straight 180°	3 A	25	Polyvinyl chloride
R419500456	Socket D-Sub 25-pin straight 180°	3 A	25	Polyvinyl chloride
R412022156	Socket D-Sub 25-pin straight 180°	3 A	25	Polyvinyl chloride
R419500457	Socket D-Sub 25-pin straight 180°	3 A	25	Polyurethane
R419500458	Socket D-Sub 25-pin straight 180°	3 A	25	Polyurethane
R419500459	Socket D-Sub 25-pin straight 180°	3 A	25	Polyurethane
R419500460	Socket D-Sub 25-pin angled 90°	3 A	25	Polyvinyl chloride
R419500461	Socket D-Sub 25-pin angled 90°	3 A	25	Polyvinyl chloride
R419500462	Socket D-Sub 25-pin angled 90°	3 A	25	Polyvinyl chloride
R412022352	Socket D-Sub 25-pin angled 90°	3 A	25	Polyvinyl chloride
R419500463	Socket D-Sub 25-pin angled 90°	3 A	25	Polyurethane
R419500464	Socket D-Sub 25-pin angled 90°	3 A	25	Polyurethane
R419500465	Socket D-Sub 25-pin angled 90°	3 A	25	Polyurethane

Part No.	Cable-Ø	Cable length		Fig.
R419500454	0.33 inch	9.84 ft.	-	Fig. 1
R419500455	0.33 inch	16.4 ft.	-	Fig. 1
R419500456	0.33 inch	32.81 ft.	-	Fig. 1
R412022156	-	-	-	Fig. 1
R419500457	0.41 inch	9.84 ft.	1)	Fig. 1
R419500458	0.41 inch	16.4 ft.	1)	Fig. 1
R419500459	0.41 inch	32.81 ft.	1)	Fig. 1
R419500460	0.33 inch	9.84 ft.	-	Fig. 2
R419500461	0.33 inch	16.4 ft.	-	Fig. 2
R419500462	0.33 inch	32.81 ft.	-	Fig. 2
R412022352	-	-	-	Fig. 2

Part No.	Cable-Ø	Cable length		Fig.
R419500463	0.41 inch	9.84 ft.	1)	Fig. 2
R419500464	0.41 inch	16.4 ft.	1)	Fig. 2
R419500465	0.41 inch	32.81 ft.	1)	Fig. 2

1) suitable for dynamic laying

## Technical information

The specified protection class is only valid in assembled and tested state.  
The increased wire cross-section of pin 25 is 0.82 mm<sup>2</sup>.

## Technical information

Material	
Housing	Thermoplastic elastomer
Cable sheath	Polyvinyl chloride Polyurethane

## Dimensions

Fig. 1

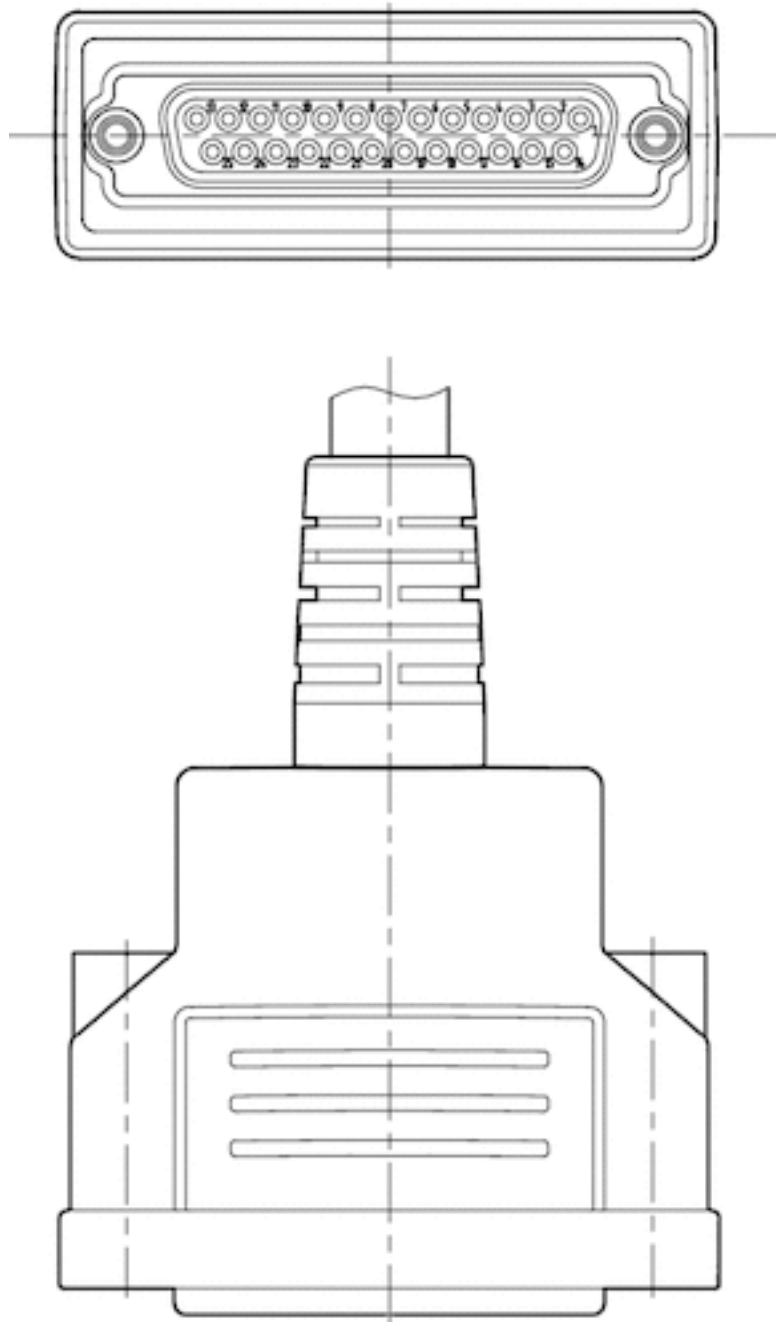
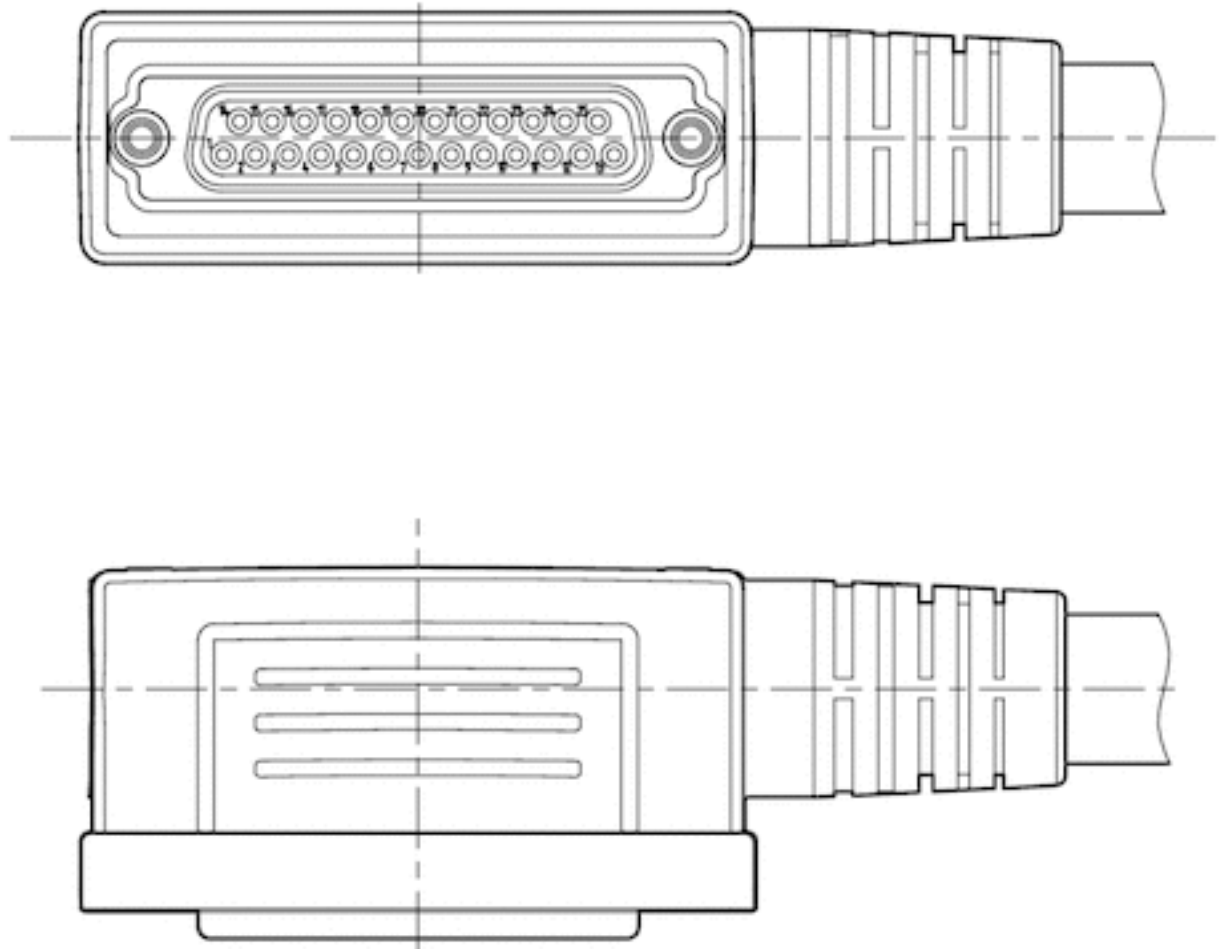

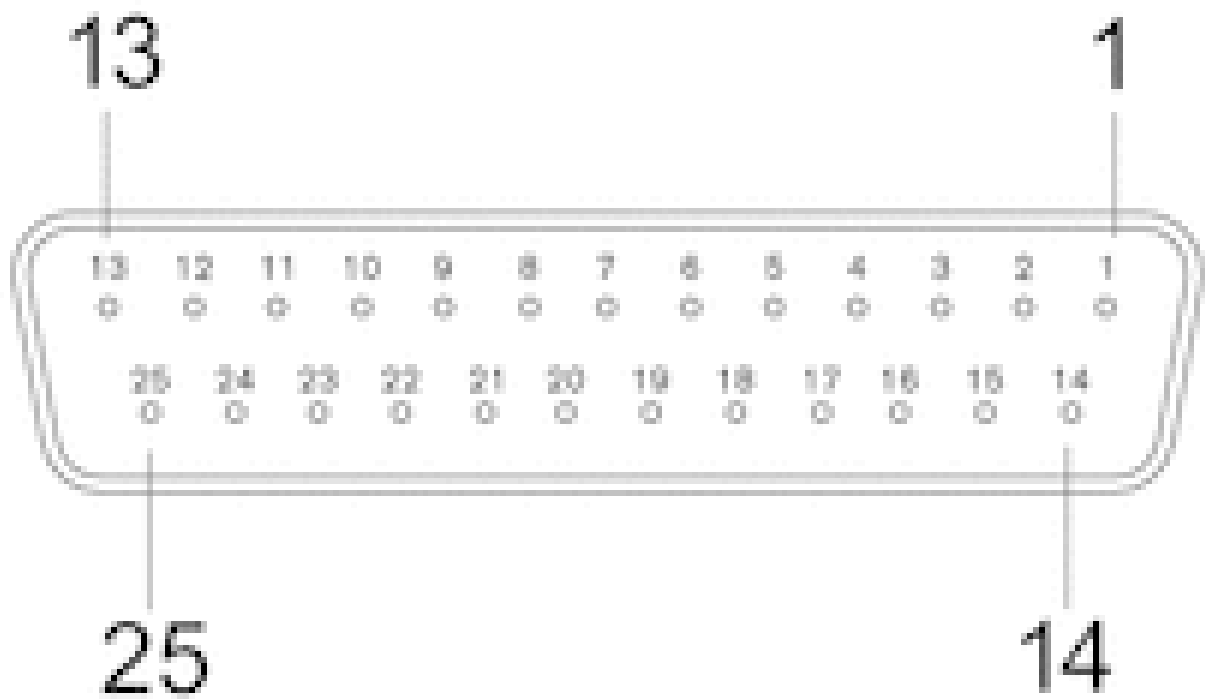

Fig. 2



## Pin assignments

PIN assignment and cable colors, cable identification as per DIN 47100



Socket

Pin	1	2	3	4	5	6	7	8	9
Color	white	brown	green	yellow	gray	pink	blue	red	black
10	11	12	13	14	15				
violet	gray/pink	red/blue	white/green	brown/green	white/yellow				
16	17	18	19	20	21				
yellow/brown	white/gray	gray/brown	white/pink	pink/brown	white/blue				
22	23	24	25						
brown/blue	white/red	brown/red	white/black						

## Coupling kit, Series ES05

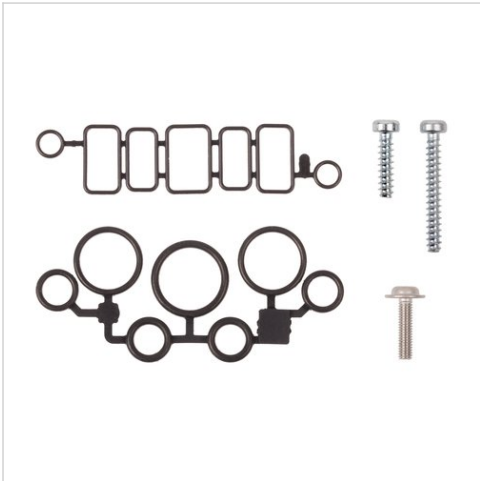

### Technical data

Part No.	Scope of delivery
R422102806	10x screws for valve function, 10x screws for tie rod, 10x screws for end plate, 10x seals for valve function, 10x seals for base plate

## Dimensions

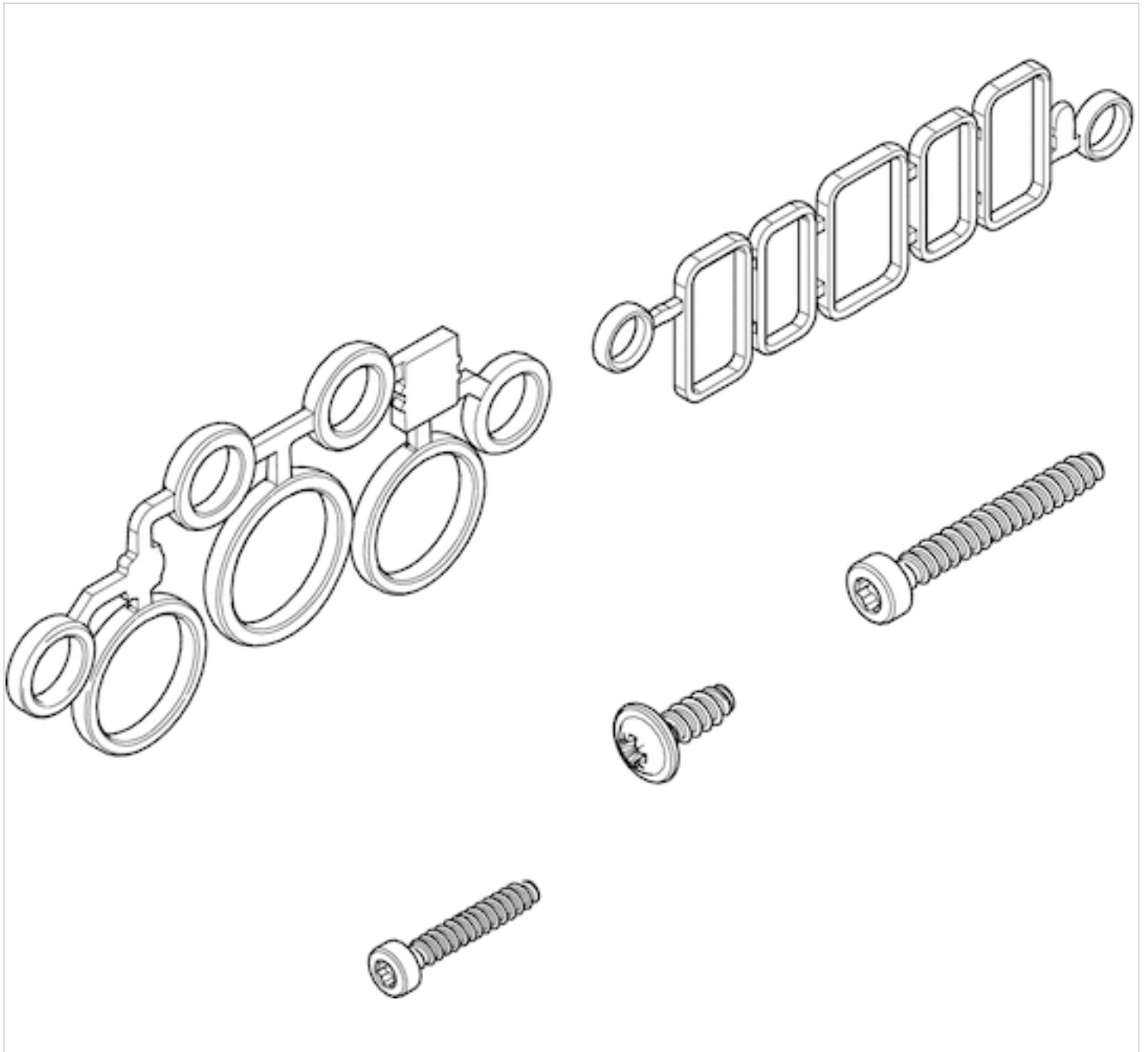

# Assembly accessories

- for ES05



## Technical data

Part No.	Type	Delivery unit
R412025511	Labels (DIN A4 with 65 labels each)	10 piece
R415016543	Essential Test Box	1 piece
R415017113	Essential Test Box, inch	1 piece
R499001652	Torque screwdriver	1 piece

# Separator

- for ES05

- standard ISO 5599-1



Standards

ISO 5599-1

Weight

0.055 lbs

## Technical data

Part No.	Type	Delivery unit
R422003353	Separator for channel 1	1 piece
R422P03353	Separator for channel 1	5 piece

When using a separator, a pressure supply plate must be used on the right side.

## Technical information

Material	
Housing	Brass
Seal	Acrylonitrile butadiene rubber

## Dimensions

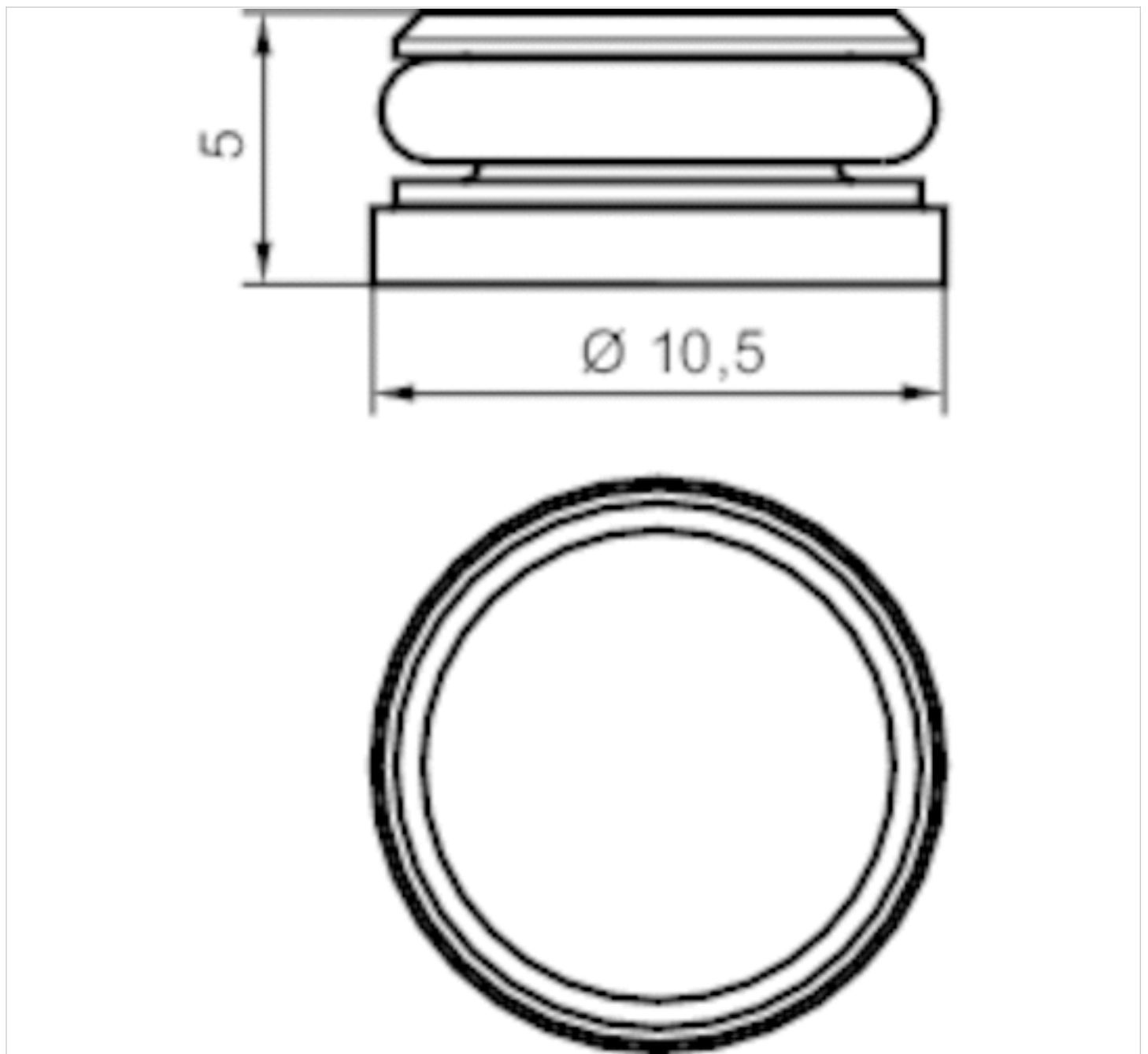



# Efficient pneumatic solutions, our program: cylinders and drives, valves and valve systems, air supply management



Visit us: [Emerson.com/Aventics](https://www.emerson.com/Aventics)

Your local contact: [Emerson.com/contactus](https://www.emerson.com/contactus)



[Emerson.com](https://www.emerson.com)



[Facebook.com/EmersonAutomationSolutions](https://www.facebook.com/EmersonAutomationSolutions)



[LinkedIn.com/company/Emerson-Automation-Solutions](https://www.linkedin.com/company/Emerson-Automation-Solutions)



[Twitter.com/EMR\\_Automation](https://twitter.com/EMR_Automation)

An example configuration is depicted on the title page. The delivered product may thus vary from that in the illustration. Subject to change. This Document, as well as the data, specifications and other information set forth in it, are the exclusive property of AVENTICS GmbH. It may not be reproduced or given to third parties without its consent. Only use the AVENTICS products shown in industrial applications. Read the product documentation completely and carefully before using the product. Observe the applicable regulations and laws of the respective country. When integrating the product into applications, note the system manufacturer's specifications for safe use of the product. The data specified only serve to describe the product. No statements concerning a certain condition or suitability for a certain application can be derived from our information. The information given does not release the user from the obligation of own judgement and verification. It must be remembered that the products are subject to a natural process of wear and aging.

The Emerson logo is a trademark and service mark of Emerson Electric Co. Brand logotype are registered trademarks of one of the Emerson family of companies. All other marks are the property of their respective owners. © 2020 Emerson Electric Co. All rights reserved.  
2020-12



**CONSIDER IT SOLVED™**