



## Axxess 6-Channel Digital Signal Processor

### INTERFACE COMPONENTS

- AXDSP-L interface
- AXDSP-L harness (16-pin & 20-pin)

### INTERFACE FEATURES

- 15 Band graphic EQ
- 4 inputs and 6 individually assignable outputs
- Independent equalization for front, rear, and sub
- Independent crossover for front, rear, and sub
- Selectable slope (12, 24, 36, or 48db per octave)
- Front and rear channels can be delayed independently up to 10ms
- Easy behind the radio installation in most applications
- Can be used with OE and aftermarket radios
- Chime control for GM/Chrysler vehicles
- Clipping detection and limiting circuits

- Internal header port for adding interface modules
- Bass knob included
- Retains OE voice prompts (SYNC® and OnStar®)
- Retains factory chimes including parking sensor and cross path detection alerts
- Settings adjusted via Bluetooth® in a smart device application (tablet or mobile phone), compatible with both Android and Apple devices
- Read, write, and store configurations for future recall
- Password protect feature available in the mobile app
- Micro-B USB updatable

### TABLE OF CONTENTS

Preface .....	2
Installation Options .....	3
Installation .....	3
Connections .....	4-7
AXDSP-L-BT Installation .....	8
AXDSP-L-SP Installation .....	9
Mobile App .....	10-19
Pinout .....	20
Specifications .....	21

### TOOLS & INSTALLATION ACCESSORIES REQUIRED

- Crimping tool and connectors, or solder gun, solder, and heat shrink
- Tape
- Wire cutter
- Zip ties
- Multimeter

### Google Play Store



### Apple App Store

iOS 12.1 or higher



## PREFACE

The AXDSP-L can be used with an aftermarket system or OEM system. The AXDSP-L can also grow as your stereo system grows. Start off by adding a subwoofer to an OEM system, then add on from there. Simply reference the **Installation Options** page to change the AXDSP-L to the new system. All 6 channels of the AXDSP-L can be assigned however needed for the installation at hand. If 6 channels of a subwoofer signal is needed, the AXDSP-L can do it.

In the following section, **Installation Options**, choose the installation type, then either click on the hyperlink, or reference the page number.

It is highly suggested to use an AXDSP-L pre-wired harness (sold separately) unless you are installing it with an aftermarket radio. As such, the instructions are written in that manner. Certain connections to the vehicle are unique per vehicle and will require the pre-wired harness to reference to.

The AXDSP-L provides a 12v 1-amp output to turn on an aftermarket amplifier. If installing multiple amplifiers, an SPDT automotive relay will be required if the current exceeds that amount. Use Metra part number **E-123** (sold separately) for best results.

If installing the AXDSP-L behind the radio to install a sub amp, the OEM amp can be retained for mids/highs. If installing the AXDSP-L at the OEM amp location, the OEM amp must be fully removed.

In most cases the CAN Bus wires need to be connected in order for the AXDSP-L to communicate with the vehicle to turn on and provide an amp turn-on output.

Inside the interface is a 16-pin header port for adding optional modules (sold separately). [Page 8](#) and [Page 9](#) will show the installation and use of these modules.

- **AXDSP-L-BT** - Bluetooth streaming interface
- **AXDSP-L-SP** - Toslink digital output

## INSTALLATION OPTIONS

### Aftermarket radio system:

The **AXDSP-L** can be used with an aftermarket radio to improve the overall listening experience for car audio enthusiasts. Installers will connect the RCA inputs from the **AXDSP-L** to the outputs from the aftermarket radio; **Front, Rear**. When using an aftermarket radio with the **AXDSP-L**, **General** must be chosen for the vehicle type.

(refer to page 4)

### Adding a subwoofer to an OEM System:

This feature offers the Installer the ability to add an aftermarket subwoofer to an OEM system. If the vehicle is equipped with noise canceling microphones, they must be disabled for this type of system.

(refer to page 5)

### Adding a full-range amplifier and subwoofer\* to an OEM system:

Similar to adding a subwoofer as mentioned prior, except for one extra step required to configure the harness for a full-range setup. Also note, if only adding the **AXDSP-L** to just the front or rear channels is desired, this can be accomplished by just using the necessary front or rear speaker wires and leaving the other speaker wires still connected.

(refer to page 6)

\*Subwoofer is optional

### Stand-alone Bluetooth system:

The **AXDSP-L** and **AXDSP-BT** can be used together as a stand-alone system and used in just about any 12V DC application. Perfect applications would be classic car installations where the dashboard cannot be altered, or in UTV vehicles. This can even be used inside a home with a 12v DC power supply. The options are endless and only limited by ones creativity.

(refer to page 7)

## INSTALLATION

### Aftermarket Radio Systems

1. Complete all necessary connections to the radio and vehicle, but leave the amp turn-on wire disconnected.

*Continue to All Systems*

### Factory Radio Systems

1. Remove the factory radio\*, then unplug all connectors.
2. Install the vehicle specific T-harness (sold separately) and make all necessary connections, but leave the amp turn-on wire disconnected.

\* Refer to [Metra online](#) for dash disassembly. If Metra makes a dash kit for the vehicle, disassembly will be within the instruction booklet.

*Continue to All Systems*

### All Systems

1. Plug the **20-pin AXDSP-L** harness into the **AXDSP-L**.
2. Plug the **16-pin AXDSP-L** harness into the **AXDSP-L**.
3. Download and install the **AX-DSP-X app** from the **Google Play Store** or **Apple App Store**.
4. Open the app then select **Bluetooth Connection** tab. Follow the instructions to pair the mobile device to the **AXDSP-L**.
5. Scroll to the **Configuration** tab then select the vehicle type. Press the **Lock Down** button to save the configuration.
6. Connect the amp turn-on wire.
7. Adjust the settings in the app as desired. Press the **Lock Down** button to save any new configurations.

# AFTERMARKET RADIO SYSTEM

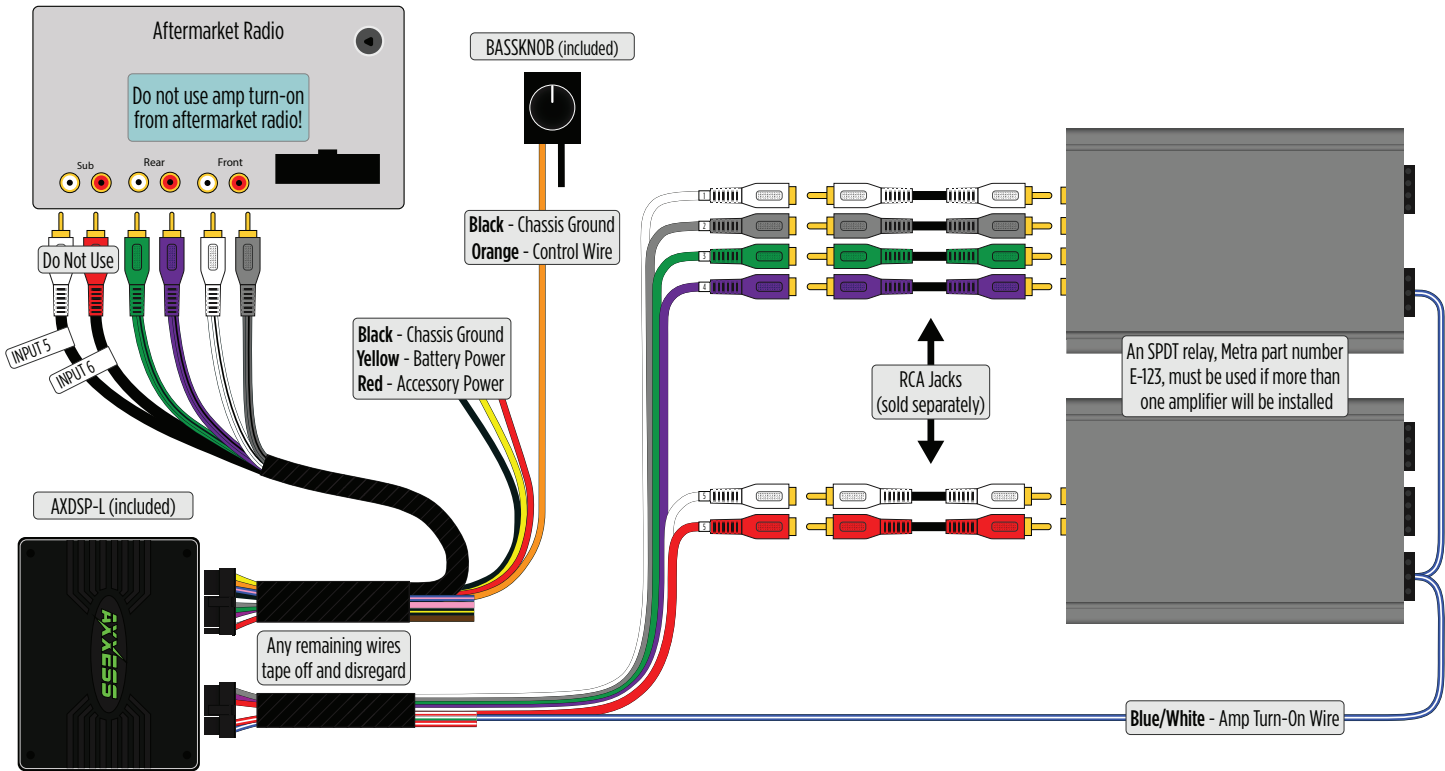

# ADDING A SUB TO AN OEM SYSTEM

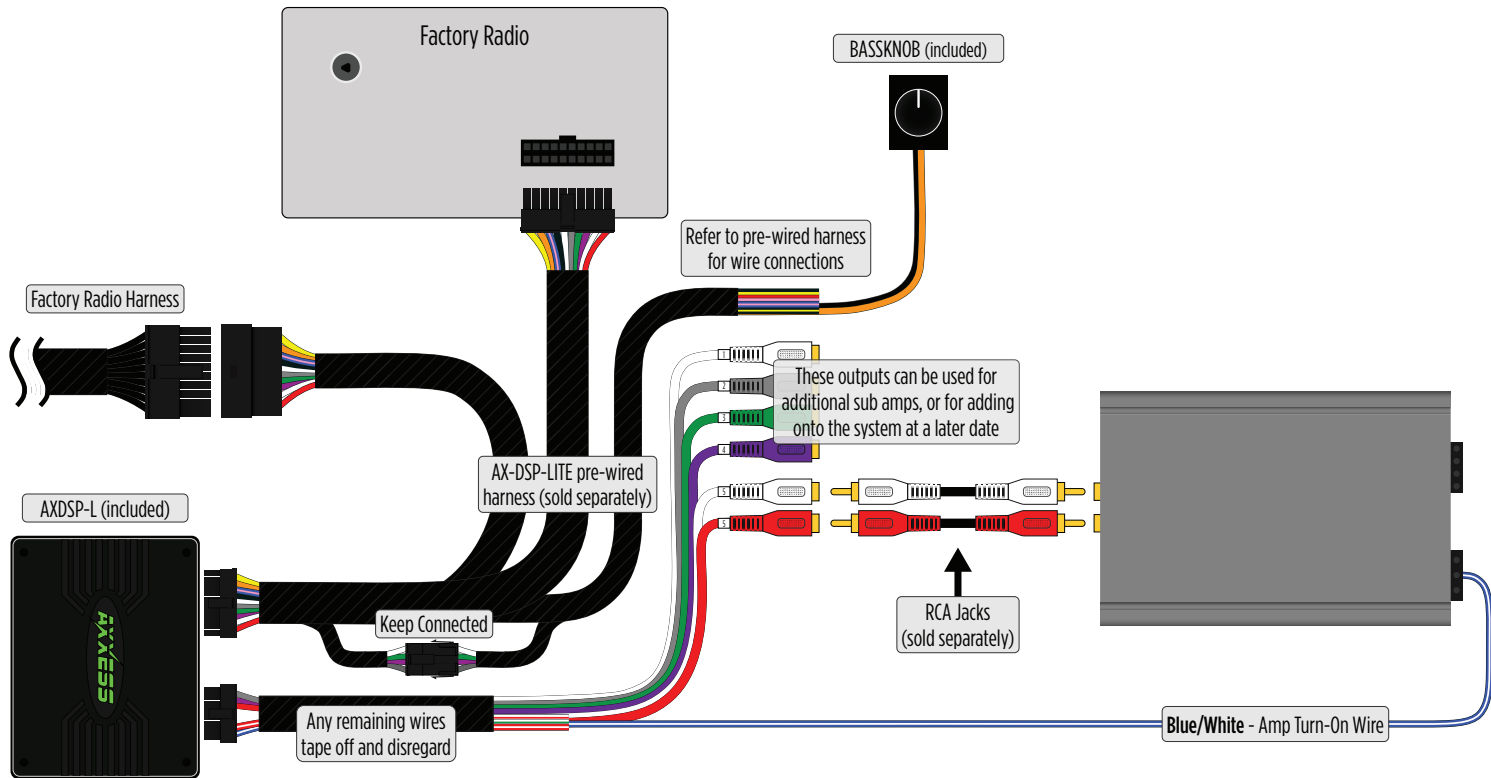

# ADDING A FULL-RANGE AMP & SUB TO AN OEM SYSTEM

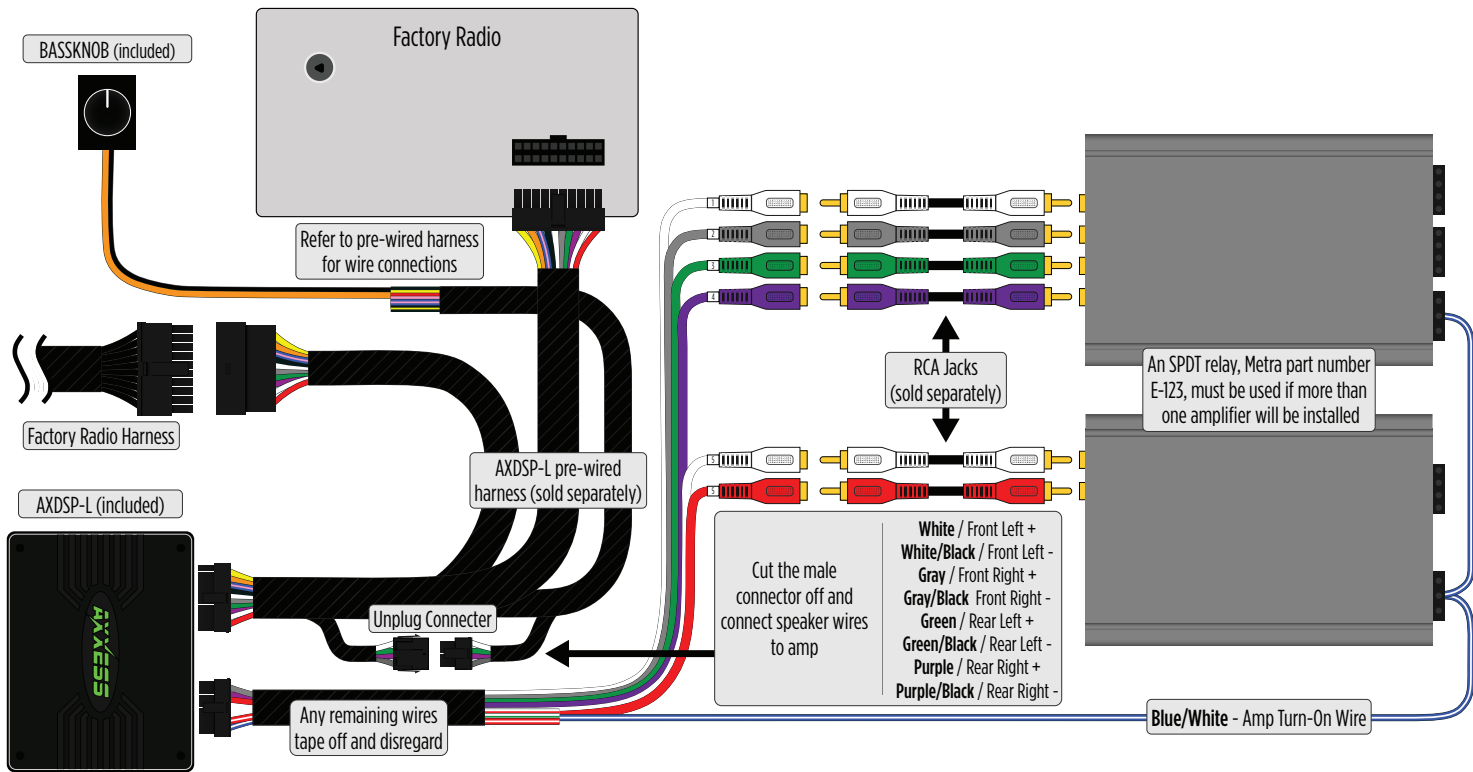

# STAND-ALONE BLUETOOTH SYSTEM

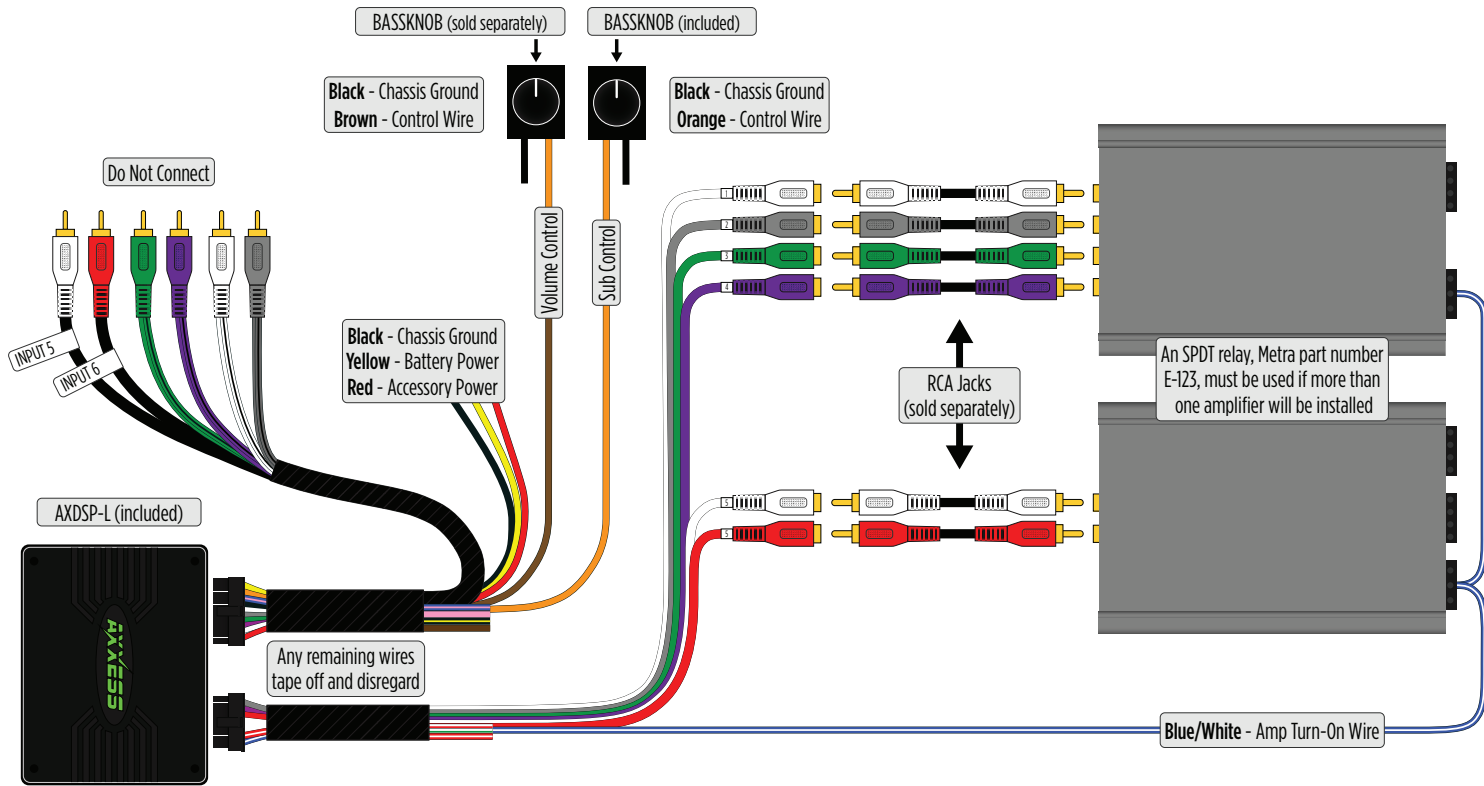

## BLUETOOTH INTERFACE

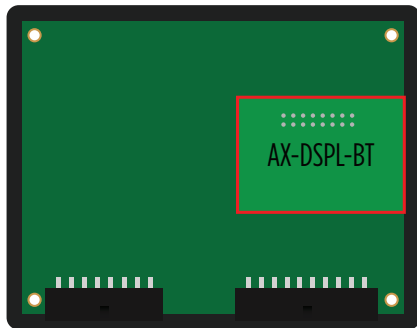
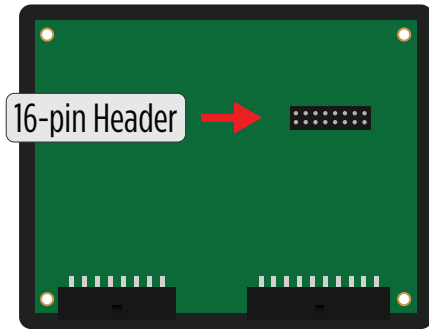

- The **AXDSPL-BT** will be used for adding a Bluetooth interface to the **AXDSP-L** for playing music files directly to the interface.
- While playing music the volume on the phone will be used. As an option, the **AXBK-1** (sold separately) can be used to control the volume.  
**Note:** The **AXBK-1** included with the **AXDSP-L** can also be used if it will not be used to control a subwoofer.

1. **Important!** Unplug the **AXDSP-L** from the vehicle.
2. Remove (4) Phillips screws securing the **AXDSP-L** interface, then remove the top cover, exposing the circuit board within.
3. Locate the 16-pin header on the circuit board.
4. **Important!** Referencing how the Bluetooth interface is laid out in the picture, carefully line up the header pins to the **AXDSPL-BT** Bluetooth interface. Gently press down to secure.

**Note:** Both interfaces may be damaged if installed wrong.

5. Reinstall the top cover to complete the installation.

### **AXBK-1 installation:**

6. Connect the **Brown** wire from the **AXDSP-L** to the **Orange** wire from the **AXBK-1**. Ground the **Black** wire from the **AXBK-1**.

*Continued on the next page*



## DIGITAL OUT INTERFACE

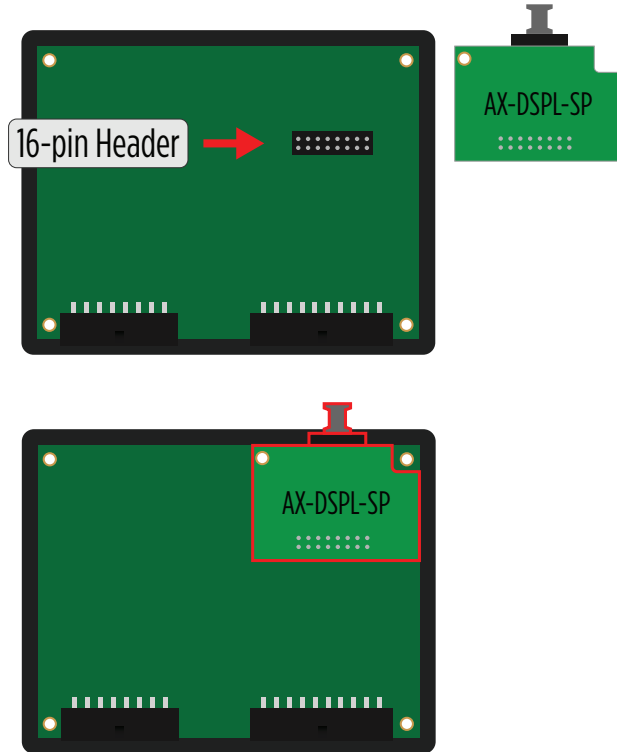

- The **AXDSPL-SP** will be used for adding a Toslink digital output to the **AXDSP-L**.
1. **Important!** Unplug the **AXDSP-L** from the vehicle.
  2. Remove (4) Phillips screws securing the **AXDSP-L** interface, then remove the top cover, exposing the circuit board within.
  3. Locate the 16-pin header on the circuit board.
  4. **Important!** Carefully line up the header pins to the Toslink interface, with the Toslink port facing outward. Gently press down to secure.  
**Note:** Both interfaces may be damaged if installed wrong.
  5. Reinstall the top cover provided with the **AXDSPL-SP** to complete the installation.

*Continued on the next page*

## Setup Instructions

SETUP INSTRUCTIONS	BLUETOOTH CONNECTION	CONFIGURATION	OUTPUTS
CROSSOVER ADJUST	EQUALIZER ADJUST	DELAY ADJUST	LEVELS

Using the vehicle specific harness, install the AX-DSP. The high level outputs from the OEM radio go to the inputs of the AX-DSP. The AX-DSP outputs are low level and should be connected to the amplifier inputs.

- Power on the system, and verify audio to the front (left and right), rear (left and right), and Subwoofer.
- Set the OEM radio bass and treble controls for flat frequency response.
- Set the left/right balance to center.
- Set the front/rear fader to center.

Detailed installation instructions are available on-line. Click the button below to view the instructions

[VIEW INSTRUCTIONS](#)

**AXXESS**<sup>®</sup>  
I N T E G R A T E

The AXDSP-L uses the same app as the AXDSP-X. Only items pertaining to the AXDSP-L will be shown.

- General information tab for installing the AXDSP-L.

*Continued on the next page*

## Bluetooth Connection

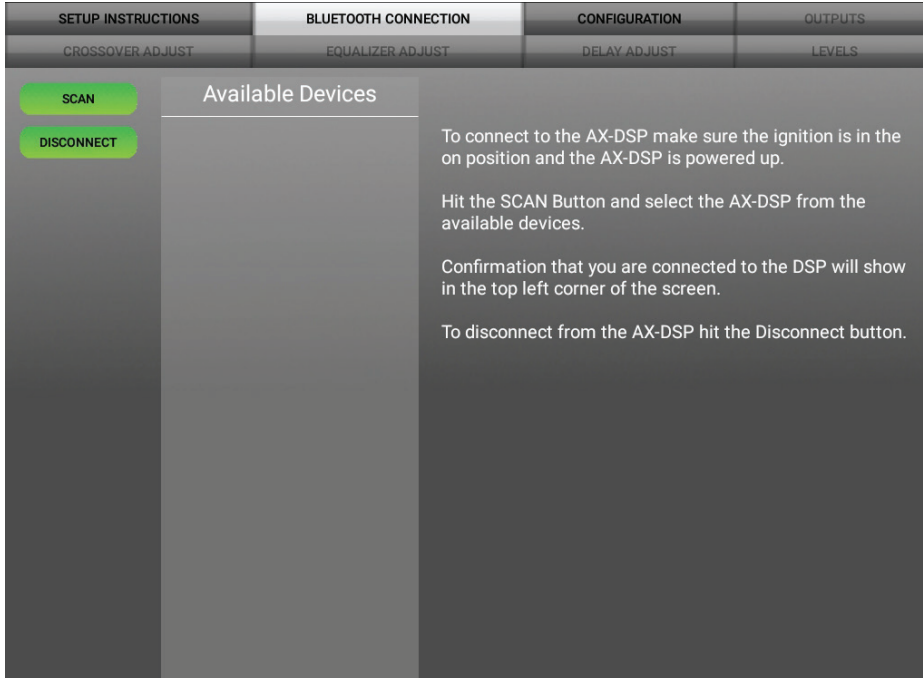

- **Scan** - Press this button to start the Bluetooth pairing process, then select AXDSP-L from the mobile device. Confirmation that you are connected will show in the top left corner of the app.
- **Disconnect** - Disconnects the AXDSP-L from the app.

*Continued on the next page*

## Configuration

SETUP INSTRUCTIONS	BLUETOOTH CONNECTION	CONFIGURATION	OUTPUTS
CROSSOVER ADJUST	EQUALIZER ADJUST	DELAY ADJUST	INPUT/LEVELS
<b>IDENTIFY</b>	Click this button to identify the AX-DSP; the chimes will play		
<b>RESET TO DEFAULTS</b>	Resets the DSP customization settings, will not reset vehicle type. During the reset process, the amplifiers will shut off for 5–10 seconds, and then turn back on once completed.		
<b>VEHICLE TYPE</b>	Select the type of vehicle the AX-DSP is installed in		
<b>LOCK DOWN</b>	Stores the current configuration into the AX-DSP		
<b>SAVE CONFIG</b>	Saves the current configuration to your device		
<b>RECALL CONFIG</b>	Recalls a configuration from your device		
<b>ABOUT</b>	Displays Information about this App and the AX-DSP		
<b>SET PASSWORD</b>	Changes password for accessing the AX-DSP		
<b>CLEAR PHONES</b>	Clears list of Phones that are paired for Bluetooth Streaming		

- **Identify** - Click this button to confirm that the AXDSP-L is connected properly. If so, a chime will be heard from the front left speaker\*.  
\* Only installations where the AXDSP-L is connected to a front left speaker.
- **Reset to Defaults** - Resets the AXDSP-L to factory settings. During the reset process the amplifiers will shut off for 5-10 seconds.
- **Vehicle Type** - Select the vehicle type from the drop down box, select either **Without OE Amplifier** or **With OE Amplifier**, then click the apply button.
- **Lock Down** - Click this button to save the selected settings.  
**Attention!** This button must be selected before closing the app or cycling the key otherwise all settings will be lost.
- **Save Configuration** - Saves the current configuration to the mobile device.
- **Recall Configuration** - Recalls a configuration from the mobile device.

*Continued on the next page*

## Configuration (Cont.)

SETUP INSTRUCTIONS	BLUETOOTH CONNECTION	CONFIGURATION	OUTPUTS
CROSSOVER ADJUST	EQUALIZER ADJUST	DELAY ADJUST	INPUT/LEVELS
<b>IDENTIFY</b>	Click this button to identify the AX-DSP; the chimes will play		
<b>RESET TO DEFAULTS</b>	Resets the DSP customization settings, will not reset vehicle type. During the reset process, the amplifiers will shut off for 5–10 seconds, and then turn back on once completed.		
<b>VEHICLE TYPE</b>	Select the type of vehicle the AX-DSP is installed in		
<b>LOCK DOWN</b>	Stores the current configuration into the AX-DSP		
<b>SAVE CONFIG</b>	Saves the current configuration to your device		
<b>RECALL CONFIG</b>	Recalls a configuration from your device		
<b>ABOUT</b>	Displays Information about this App and the AX-DSP		
<b>SET PASSWORD</b>	Changes password for accessing the AX-DSP		
<b>CLEAR PHONES</b>	Clears list of Phones that are paired for Bluetooth Streaming		

- **About** - Displays information about the app, vehicle, AXDSP-L, and mobile device.
- **Set Password** - Assign a 4-digit password to lock the AXDSP-L. If no password is desired, use “0000”. This will clear out any currently set password. It is not necessary to lock down the AXDSP-L when setting a password.  
**Note:** A 4-digit only password must be chosen otherwise the AXDSP-L will show “password not valid for this device”.
- **Clear Phones** - Clears phones paired from memory

*Continued on the next page*

## Outputs

SETUP INSTRUCTIONS	BLUETOOTH CONNECTION	CONFIGURATION	OUTPUTS
CROSSOVER ADJUST	EQUALIZER ADJUST	DELAY ADJUST	INPUT/LEVELS
<u>Output Channels</u>			
#	Location	Group	
1	Left Front	None	<input type="checkbox"/> Invert <input type="checkbox"/> Mute
2	Right Front	None	<input type="checkbox"/> Invert <input type="checkbox"/> Mute
3	Left Rear	None	<input type="checkbox"/> Invert <input type="checkbox"/> Mute
4	Right Rear	None	<input type="checkbox"/> Invert <input type="checkbox"/> Mute
5	Sub Woofer	None	<input type="checkbox"/> Invert <input type="checkbox"/> Mute

### Output Channels

- **Location** - Location of speaker.
- **Group** - Used to join channels together for simple equalization. Example, left front woofer/midrange and left front tweeter will be considered simply left front. The letter **M** denotes the speaker assigned as the master speaker.
- **Invert** - Will invert the phase of the speaker.
- **Mute** - Will mute desired channel(s) for tuning individual channels.

*Continued on the next page*

## Crossover Adjust

SETUP INSTRUCTIONS	BLUETOOTH CONNECTION	CONFIGURATION	OUTPUTS
CROSSOVER ADJUST	EQUALIZER ADJUST	DELAY ADJUST	INPUT/LEVELS
<b>Left Front</b> Lower Freq: 100 Hz <input type="radio"/> Low Pass <input type="radio"/> 12dB <input type="radio"/> Band Pass <input checked="" type="radio"/> 24dB <input checked="" type="radio"/> High Pass <input type="radio"/> 36dB <input type="radio"/> 48dB			
<b>Right Front</b> Lower Freq: 100 Hz <input type="radio"/> Low Pass <input type="radio"/> 12dB <input type="radio"/> Band Pass <input checked="" type="radio"/> 24dB <input checked="" type="radio"/> High Pass <input type="radio"/> 36dB <input type="radio"/> 48dB			
<b>Left Rear</b> Lower Freq: 46 Hz <input type="radio"/> Low Pass <input type="radio"/> 12dB <input type="radio"/> Band Pass <input checked="" type="radio"/> 24dB <input checked="" type="radio"/> High Pass <input type="radio"/> 36dB <input type="radio"/> 48dB			
<b>Right Rear</b> Lower Freq: 100 Hz <input type="radio"/> Low Pass <input type="radio"/> 12dB <input type="radio"/> Band Pass <input checked="" type="radio"/> 24dB <input checked="" type="radio"/> High Pass <input type="radio"/> 36dB <input type="radio"/> 48dB			
<b>Sub Woofer</b> Upper Freq: 100 Hz <input checked="" type="radio"/> Low Pass <input type="radio"/> 12dB <input type="radio"/> Band Pass <input checked="" type="radio"/> 24dB <input type="radio"/> High Pass <input type="radio"/> 36dB <input type="radio"/> 48dB			

- If installing a subwoofer, the front and rear outputs will default to a 100Hz high pass filter to keep the low frequency signals out. If a subwoofer is not being installed, change the front and rear crossover points down to 20Hz for a full range signal, or to the lowest frequency the speakers will play down to.
- Selecting **High Pass** and **Low Pass** will provide one crossover frequency adjustment. **Band Pass** should only be chosen if installing just front speakers, with one dedicated amp for the woofers/mids, a second dedicated amp for the tweeters, along with a subwoofer.
- Select the desired crossover slope, 24db, 36db, or 48 db. Higher is steeper.

*Continued on the next page*

## Equalizer Adjust

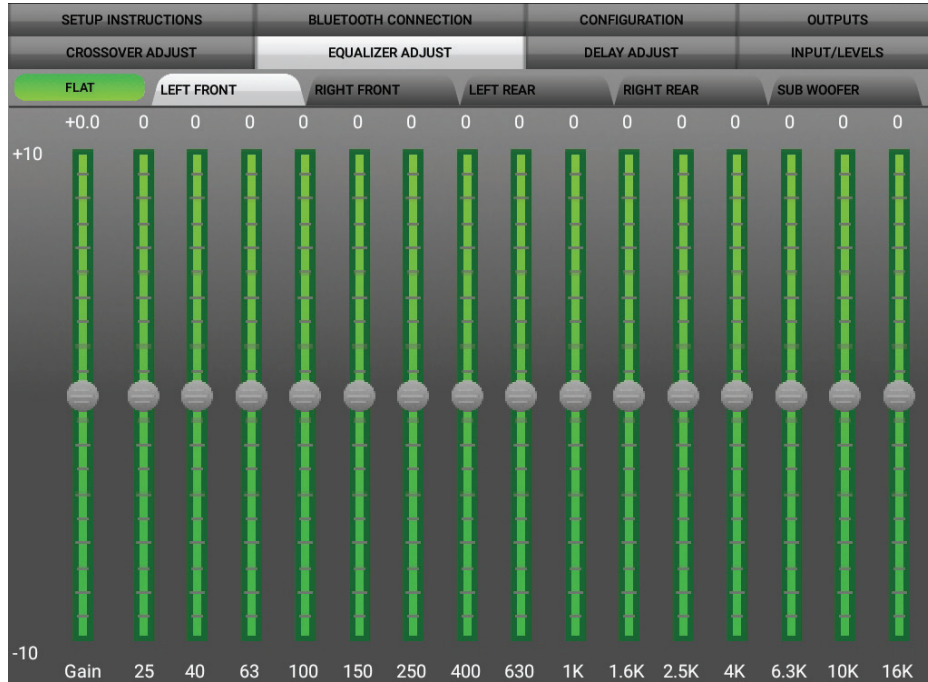

- The front, rear, and sub channels can be adjusted independently within this tab with 15 bands of equalization available. It is best to tune this by using an RTA (Real Time Analyzer).
- The **Gain** slider on the far left is for the channel selected.

*Continued on the next page*



## Delay Adjust

SETUP INSTRUCTIONS	BLUETOOTH CONNECTION	CONFIGURATION	OUTPUTS
CROSSOVER ADJUST	EQUALIZER ADJUST	DELAY ADJUST	INPUT/LEVELS
<u>Distance from each speaker to 'Head' position (in inches)</u>			
Left Front	0		
Right Front	0		
Left Rear	0		
Right Rear	0		
Sub Woofer	0		
<p>Measure the distance from each speaker to the desired 'Head' position and enter those values in the corresponding boxes. Maximum distance is 99".</p>			

- Allows a delay of each channel, up to 10 milliseconds. First measure the distance (in inches) from each speaker to the listening position, then enter those values. If a delay is desired, add to the desired channel(s), up to 99 inches.

*Continued on the next page*

## Inputs/Levels

SETUP INSTRUCTIONS	BLUETOOTH CONNECTION	CONFIGURATION	OUTPUTS
CROSSOVER ADJUST	EQUALIZER ADJUST	DELAY ADJUST	INPUT/LEVELS

Chime Volume

Low      Medium      High

Volume: 5 

The Chime Volume control is provided to prevent warning tones from being overly loud.

- **Chime Volume** - Allows the chime volume to be adjusted up or down.

**Note:** In newer Ford vehicles chimes will be heard through the gauge cluster if the OEM amplifier is removed

*Continued on the next page*

## Locking Down Data

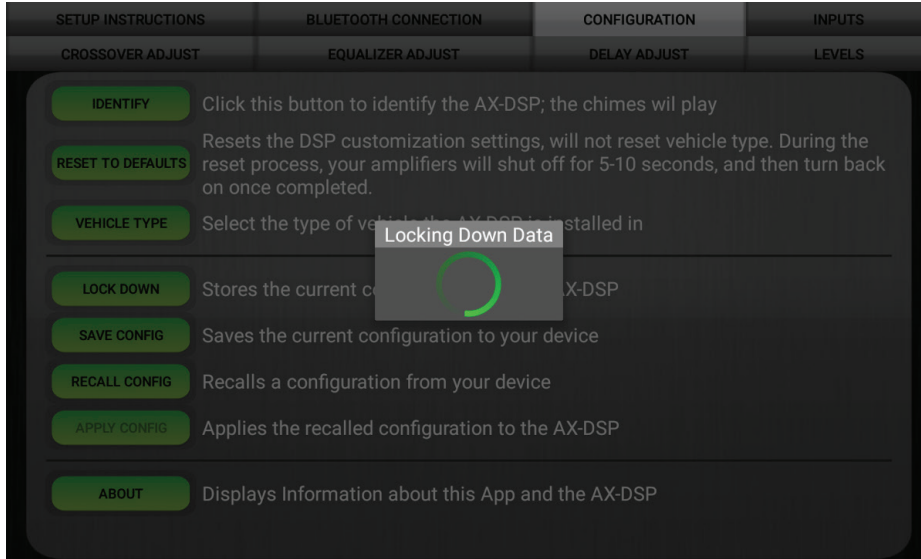

**Last and the most important.  
You must lock down your configuration!!!**

## PINOUT

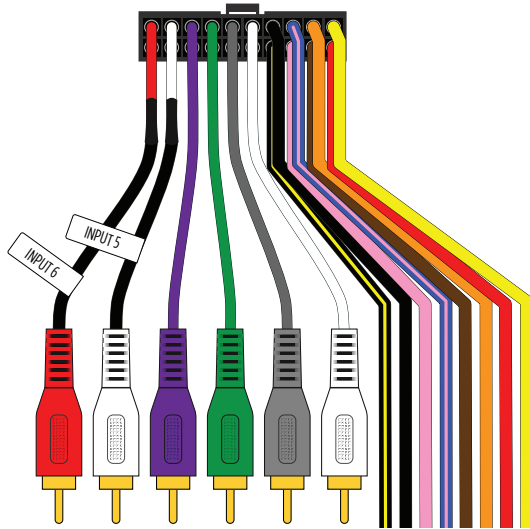

**Input 6** - N/A

**Input 5** - N/A

**Purple RCA Jack** - Rear Right Input \*

**Green RCA Jack** - Rear Left Input \*

**Gray RCA Jack** - Front Right Input \*

**White RCA Jack** - Front Left Input \*

**Black/Yellow** - Future Use

**Black** - Chassis Ground

**Pink** - CAN-HI

**Blue/Pink** - CAN-LO

**Brown** - Control Wire for BT Volume Knob

**Orange** - Control Wire for Bass Knob

**Red** - Accessory Power

**Yellow** - Battery Power

\* Cut off RCA jack for speaker level input

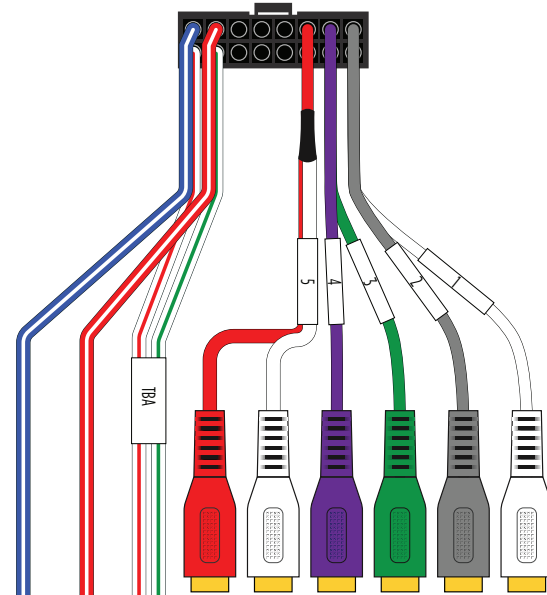

**Blue/White** - Amp Turn-On

**Red/White** - Future Use

**White/Red** - Future Use

**White/Green** - Future Use

**RCA Jack 1** - User Assignable Output

**RCA Jack 2** - User Assignable Output

**RCA Jack 3** - User Assignable Output

**RCA Jack 4** - User Assignable Output

**RCA Jack 5** - User Assignable Output

# SPECIFICATIONS

## Specifications

Input Impedance	1M Ohm
Input Channels	4
Input Options	High-level or Low-level selectable
Input Type	Differential-Balanced
Input Voltage	
High Level Range	0 - 28-volts (peak-to-peak)
Input Voltage	
Low Level Range	0 - 4.9-volts (peak-to-peak)
Output Channels	6
Output Voltage	Up to 5-volts RMS
Output Impedance	50 Ohms
Equalizer Type	15 Band Graphic EQ, +/- 10dB
THD	<0.03%
Frequency Response	20Hz - 20kHz
Crossover	2-Way low-pass (sub), high pass (front & rear)
Crossover Type	Linkwitz-Riley 24db slope, fixed
Sampling	48kHz
S/N Ratio	105dB @ 5-volts RMS

## General

Operating Voltage	10-16-volts DC
Standby Current Draw	7mA
Operation Current Draw	150mA
Adjustments/Controls	Application via Bluetooth
Remote Output	12-volts DC (signal sense or with ignition)



# AXDSP-L

INSTALLATION INSTRUCTIONS

Having difficulties? We're here to help.



Contact our Tech Support line at:

**1-800-253-TECH**



Or via email at:

[techsupport@metra-autosound.com](mailto:techsupport@metra-autosound.com)

### **Tech Support Hours (Eastern Standard Time)**

Monday - Friday: 9:00 AM - 7:00 PM

Saturday: 10:00 AM - 7:00 PM

Sunday: 10:00 AM - 4:00 PM



### **KNOWLEDGE IS POWER**

Enhance your installation and fabrication skills by enrolling in the most recognized and respected mobile electronics school in our industry. Log onto [www.installerinstitute.com](http://www.installerinstitute.com) or call 800-354-6782 for more information and take steps toward a better tomorrow.



**Metra recommends MECP  
certified technicians**