

8 Maintenance

8.1 General maintenance instructions

Safety notes



WARNING



Danger of injury from failure to follow the operating instructions and from performing unauthorized tasks on the machine.

- Follow all instructions.
- Do not perform activities for which no qualification is available. Contact properly trained personnel if necessary.

NOTICE



Comply with the safety chapter!

Follow the basic safety instructions in chapter 3 *Safety*, page 7.

- Maintenance tasks may only be performed by trained personnel.
- Accident prevention measures must be in accordance with the local accident prevention regulations.
- Perform setting and maintenance work at the specified intervals.
- Replace faulty machine parts as soon as possible.
- Always wear personal protection equipment.
- Only use fully functional tools.
- Installation of unsuitable spare parts can lead to problems. We cannot accept responsibility for direct damage or secondary damage that results from this. We therefore recommend the use of **Hatz original spare parts**.
- Closely adhere to the maintenance conditions prescribed in this manual.
- Only make changes on the machine in agreement with the manufacturer.
- Only perform maintenance when the engine is switched off.
- Protect start-up devices (crank handle, recoil start or starting key) from unauthorized access.
- After completing maintenance work, check that all tools, bolts, aids, and other objects are removed from the machine, and that all safety equipment has been replaced.
- Before starting, ensure that no persons are located in the danger zone of the engine or machine.
- Adhere to legal regulations when handling and disposing of used oil, filters, and cleaning agents.

- For engines with an electric starter: Disconnect the negative battery terminal before carrying out maintenance work.



Performance of maintenance work

The entire machine is designed to be maintenance friendly. Parts that require maintenance are easily accessible.

- Perform maintenance work faithfully at the specified intervals to prevent premature wear of the machine.
- Follow the notice and warning labels on the machine.
- Always retighten screw connections loosened during maintenance work.
- After the necessary maintenance and repair work is completed, perform a function test (test run).
- For maintenance work that is not listed and described in the maintenance documentation, please contact your nearest **HATZ service station**.

8.2 Maintenance work

Safety note

 CAUTION	
	<p>Danger of injury if maintenance instructions are not followed.</p> <ul style="list-style-type: none"> ▪ Only perform maintenance when the engine is switched off. ▪ Protect start-up devices (crank handle, recoil start or starting key) from unauthorized access. ▪ For engines with a starter: Disconnect the negative battery terminal. ▪ When the maintenance work has been completed, ensure that all tools are removed from the machine.

8.2.1 Maintenance notice label

NOTICE	
	<p>Depending on the engine type, one of the maintenance plans shown below is supplied with the engine.</p> <ul style="list-style-type: none"> ▪ It should be mounted on the engine or machine in a clearly visible location. ▪ The maintenance intervals specified on the maintenance plan must be adhered to (see chapter 8.2.2 <i>Maintenance plan</i>, page 61)

2M41. Without oil sump

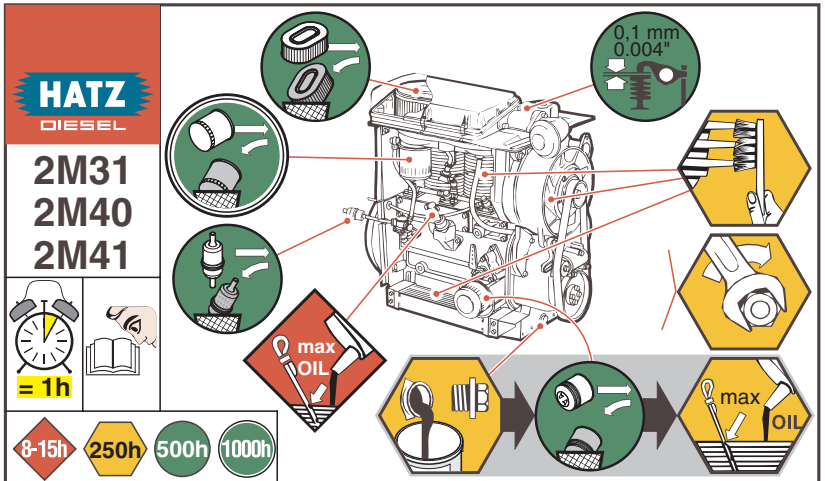

2M41. With oil sump; 3-4M41. and 4M42 in general

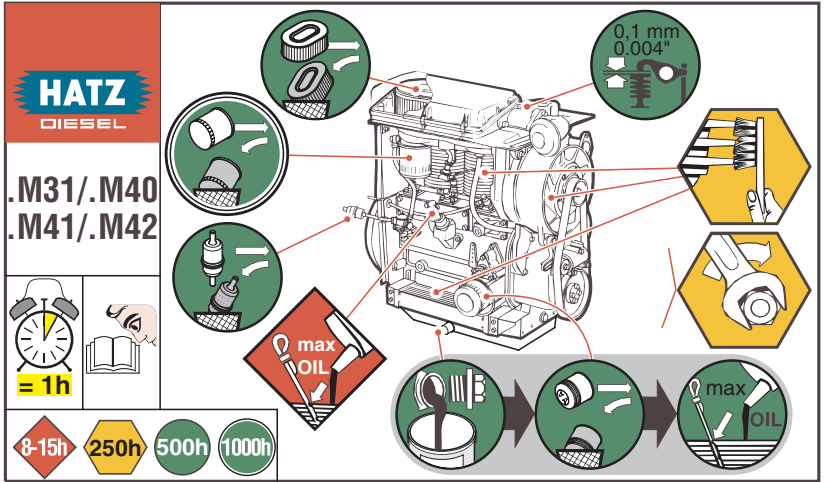

2-4L41C; 4L42C

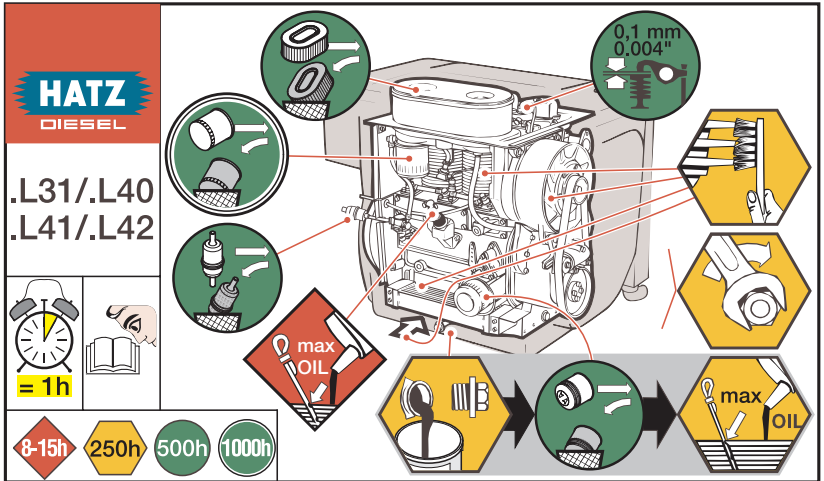

8.2.2 Maintenance plan

In new and generally overhauled engines, after **25 operating hours**:

- Change the engine oil
- Check the tappet clearance and adjust if necessary
- Check the screw connections (do not retighten the screws for attaching the cylinder head)

In case of a low number of operating hours, change the engine oil no later than every 12 months, regardless of the actual number of operating hours.

The degree of contamination of the fuel, the care with which refueling is performed and the soiling on the inside of the fuel tank are decisive in determining the change interval of the fuel **pre**filter and the main fuel filter.





Symbol	Maintenance interval	Maintenance step/check	Chapter
	Every 8–15 operating hours or every day before starting	Check the oil level.	<i>7.9 Checking the oil level and adding oil if necessary, page 55</i>
		Check the intake area of the combustion air.	<i>8.2.3 Checking the intake area of the combustion air, page 64</i>
		Check the cooling air area.	<i>8.2.4 Checking the cooling air area, page 66</i>
		Visual check of the condition of the crank handle (handle bar, crank arm, drive dog) If necessary, lightly grease gliding area between crank handle and guide sleeve.	–
	Weekly	Check the water separator.	<i>7.8 Checking the water separator, page 54</i>

Symbol	Maintenance interval	Maintenance step/check	Chapter
 250h	Every 250 operating hours	Change the engine oil (2M41. without oil sump, 2-4L41C and 4L42C in general).	8.2.5 <i>Change the engine oil, page 67</i>
		Check the poly v belt.	8.2.6 <i>Checking the poly v belt, page 69</i>
		Clean the cooling fan, cooling fins and oil cooler.	8.2.7 <i>Cleaning the cooling fan, cooling fins and oil cooler, page 71</i>
		Check the screw connections.	8.2.8 <i>Checking the screw connections, page 74</i>
		Clean the screen insert in the exhaust pipe.	8.2.9 <i>Cleaning the screen insert in the exhaust pipe (additional equipment), page 74</i>
		Check the water separator.	7.8 <i>Checking the water separator, page 54</i>
		Check the fuel pre filter for contamination and change it if necessary.	8.2.10 <i>Changing the fuel prefilter, page 76</i>
		Check the air filter maintenance indicator.	8.2.16 <i>Checking that the air filter maintenance indicator is working properly, page 91</i>

Symbol	Maintenance interval	Maintenance step/check	Chapter
500h	Every 500 operating hours	Change the fuel pre filter.	<i>8.2.10 Changing the fuel prefilter, page 76</i>
		Maintain the dry air filter. Change the filter cartridge.	<i>8.2.11 Maintaining the dry air filter, page 78</i>
		Check and set the tappet clearance.	<i>8.2.13 Check and set the tappet clearance, page 82</i>
		Change the engine oil (2M41. with oil sump, 3-4M41. and 4M42 in general).	<i>8.2.5 Change the engine oil, page 67</i>
		Change the oil filter.	<i>8.2.14 Changing the oil filter, page 86</i>
1000h	Every 1000 operating hours	Change the main fuel filter	<i>8.2.15 Change the main fuel filter, page 87</i>
---	Every 2000 operating hours	Renew the gaskets in the belt tensioner or the complete belt tensioner. (To be carried out by a trained specialist)	
		Renew the poly v belt.	<i>8.2.17 Renewing the poly v belt and checking the function of the switch-off unit, page 93</i>
---	Every 3000 operating hours (4L42C and 4M42 only)	Clean the EGR valve, EGR housing, and intake area. (To be carried out by a trained specialist)	---

8.2.3 Checking the intake area of the combustion air

Safety notes

 CAUTION	
 	<p>Danger of burns.</p> <p>There is a danger of burns when working on a hot engine.</p> <ul style="list-style-type: none"> ▪ Let the engine cool. ▪ Wear safety gloves.
NOTICE	
	<p>In case of heavy contamination, shorten the maintenance intervals accordingly (see chapter 8.2.2 <i>Maintenance plan</i>, page 61).</p>

Overview

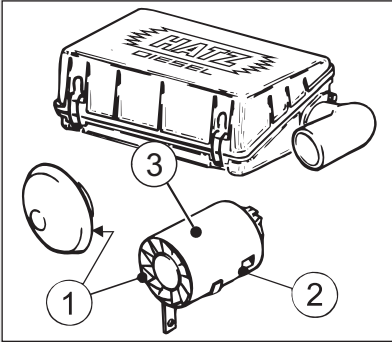
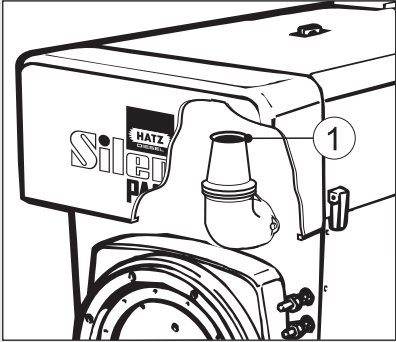
2-4M41 and 4M42	2-4L41C and 4L42C
	
Pos.	Designation
1	Intake opening for combustion air
2	Dust outlet opening
3	Cyclone (option)

Procedure

Step	Activity
1	Check the intake opening (1) for coarse contamination such as leaves, heavy dust deposits, etc., and clean if necessary.
2	Check that the dust outlet opening (2) at the bottom of the cyclone precleaner is clear.
3	If the dirt contamination is oily, remove the cyclone (3) and clean it.

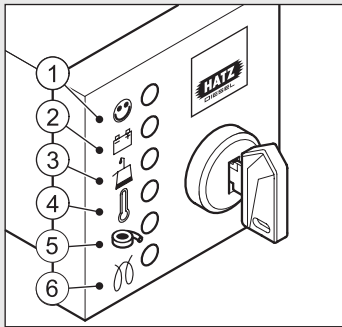
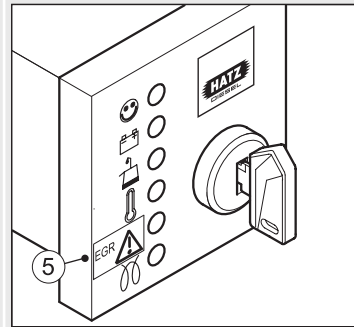
Electrical air filter maintenance display**2-4L41C and 2-4M41****4L42C and 4M42**

Pos.	Designation
5	Air filter maintenance display

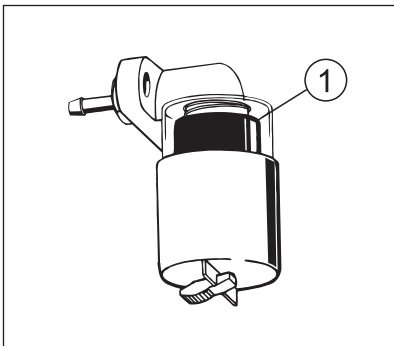
Mechanical air filter maintenance display





Pos.	Designation
1	Red field

Procedure

Step	Activity
For the electrical air filter maintenance display:	
1	<p>Briefly let the engine run at maximum speed and watch for the indicator (5) to light up for a short period – depending on the version.</p> <p>In the engines 4L42C and 4M42, the following flash code indicates that maintenance work is required on the air filter</p> <ul style="list-style-type: none"> ▪ 7 short flashes (approx. 0.5 seconds) and ▪ 1 long flash (approx. 1.5 seconds) <p>(see the chapter <i>8.2.11 Maintaining the dry air filter, page 78</i>).</p>
With mechanical air filter maintenance display:	
1	<p>Briefly let the engine run at maximum speed and watch for the visible red field (1) in the mechanical air filter maintenance display.</p> <p>The visible red field (1) indicates that maintenance work is required on the air filter (see the chapter <i>8.2.11 Maintaining the dry air filter, page 78</i>).</p>

8.2.4 Checking the cooling air area

Safety notes

 CAUTION	
	<p>Danger of burns.</p> <p>There is a danger of burns when working on a hot engine.</p> <ul style="list-style-type: none"> ▪ Let the engine cool before maintenance.
 CAUTION	
 	<p>Danger of injury.</p> <p>When working with compressed air, foreign bodies may fly into your eyes.</p> <ul style="list-style-type: none"> ▪ Wear safety goggles. ▪ Never direct the compressed air jet toward people or toward yourself.

CAUTION**Danger of engine damage from overheating.**

The engine temperature display (option) lights up as soon as the engine becomes impermissibly hot.

- Switch off the engine immediately and eliminate the cause.

NOTICE

In case of heavy contamination, shorten the maintenance intervals accordingly (see chapter 8.2.2 *Maintenance plan*, page 61).

Procedure

Step	Activity
1	Check the supply and exhaust air areas for coarse contamination such as leaves, heavy dust deposits, etc., and clean if necessary (see chapter 8.2.7 <i>Cleaning the cooling fan, cooling fins and oil cooler</i> , page 71).

8.2.5 Change the engine oil**Safety notes****CAUTION****Danger of burns.**

When working on the engine there is a danger of burns from hot oil.



- Wear personal protective equipment (gloves).
- Collect the used oil and dispose of it according to local environmental regulations.

NOTICE

- The engine must be level.
- The engine must be switched off.
- Only drain engine oil while it is warm.

Overview

M41

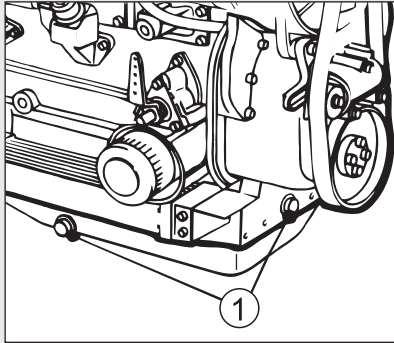

L41

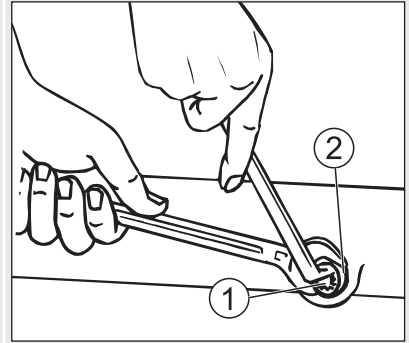

Pos.	Designation
1	Oil drain screw
2	Drain pipe

Draining the oil

Step	Activity
1	<p>Unscrew the oil drain screw (1) and drain the oil entirely.</p> <p>When unscrewing the oil drain screw (1) on engines of type 2-4L41C and 4L42C, ensure that the drain pipe (2) is not loosened. Hold it with an open-end wrench.</p>
2	Screw in the cleaned oil drain screw (1) with the new gasket and tighten.

Overview

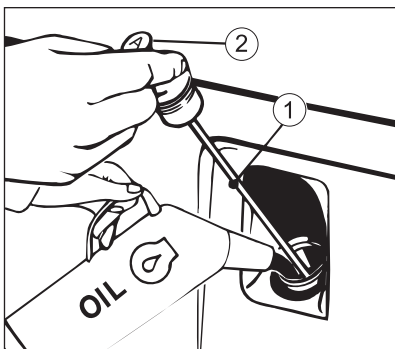





Pos.	Designation
1	Dipstick
2	Code letter on the dipstick

Procedure — Adding oil

Step	Activity
1	<p>Add engine oil to the max. mark on the dipstick (1).</p> <ul style="list-style-type: none"> ▪ For the specification and viscosity, see chapter 4.3 <i>Engine oil, page 25</i>. ▪ The code letter on the dipstick (2) indicates whether the engine is equipped with an oil sump or not (see chapter 4 <i>Technical data, page 22</i>).
2	Reinsert the dipstick (1).
3	After a short test run, check the oil level and correct it if necessary (see the chapter 7.9 <i>Checking the oil level and adding oil if necessary, page 55</i>).

8.2.6 Checking the poly v belt

Safety notes

 CAUTION	
	<p>Danger of burns.</p> <p>There is a danger of burns when working on a hot engine.</p> <ul style="list-style-type: none"> ▪ Let the engine cool before maintenance.
 CAUTION	
	<p>Damage from inadequate engine cooling.</p> <p>Only operate the engine when all covers are installed.</p>

Preparation

Step	Activity
1	On encapsulated engines , unscrew the cover of the air guide housing (see chapter 5 <i>Engine design, page 26</i>).
1	On engines without a capsule , unscrew the belt guard (see chapter 5 <i>Engine design, page 26</i>).

Overview

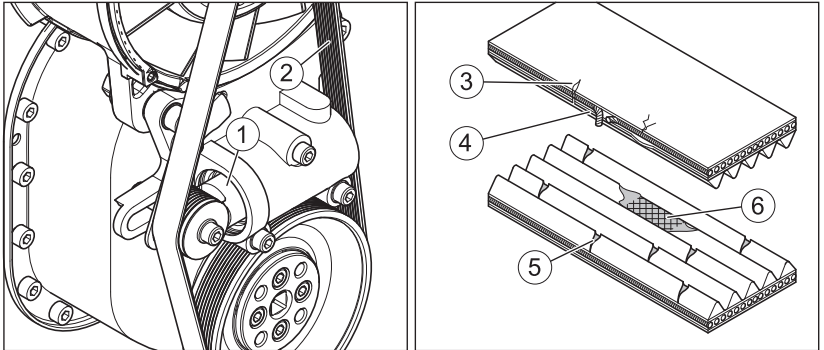

1	Belt tensioner
---	----------------

2	Poly v belt
---	-------------

Damage on the poly v belt

3	Transverse cracks on the rear
---	-------------------------------

4	Fraying on the edges
---	----------------------

5	Transverse cracks in multiple ribs
---	------------------------------------







6	Broken ribs
---	-------------

Procedure

Step	Activity
1	Check the belt tensioner (1) for leaks. If the belt tensioner is oily, contact HATZ service .
2	<p>Check the poly v belt (2) for the following damage:</p> <ul style="list-style-type: none"> ▪ Transverse cracks on the rear of the belt. ▪ Fraying on the side. ▪ Accumulation of dirt between the ribs. ▪ Oily dirt contamination. ▪ Transverse cracks in multiple ribs. ▪ Broken ribs. <p>If one or more of these instances of damage are present, replace the poly v belt (see chapter 8.2.17 <i>Renewing the poly v belt and checking the function of the switch-off unit</i>, page 93).</p>
3	Refit the air guide housing cover and belt guard.

8.2.7 Cleaning the cooling fan, cooling fins and oil cooler

Safety notes

 DANGER	
	<p>Danger of explosion from flammable cleaning agents.</p> <p>Cleaning with benzene is an explosion hazard. It is highly flammable, can become electrostatically charged, and can generate an explosive gas/air mixture.</p> <ul style="list-style-type: none"> ▪ Use halogen-free, cold cleaners with a high flashpoint for cleaning. ▪ Comply with manufacturer's instructions.
 CAUTION	
	<p>Danger of burns.</p> <p>There is a danger of burns when working on a hot engine.</p> <ul style="list-style-type: none"> ▪ Let the engine cool before maintenance.
 CAUTION	
 	<p>Danger of injury.</p> <p>When working with compressed air, foreign bodies may fly into your eyes.</p> <ul style="list-style-type: none"> ▪ Wear safety goggles. ▪ Never direct the compressed air jet toward people or toward yourself.
CAUTION	
	<p>Danger of engine damage from overheating.</p> <p>The engine temperature display (option) lights up as soon as the engine becomes impermissibly hot.</p> <ul style="list-style-type: none"> ▪ Switch off the engine immediately and eliminate the cause.
CAUTION	
	<p>Danger of damage to the machine from incorrect engine cleaning.</p> <ul style="list-style-type: none"> ▪ Let the engine fully cool down before cleaning. ▪ Do not spray components of the electrical equipment with a water jet or high pressure jet during cleaning. ▪ Do not use gasoline or acid-based cleaning agents.

**CAUTION****Damage from inadequate engine cooling.**

Only operate the engine when all covers are installed.

NOTICE

In case of heavy contamination, shorten the maintenance intervals accordingly (see chapter 8.2.2 *Maintenance plan, page 61*).

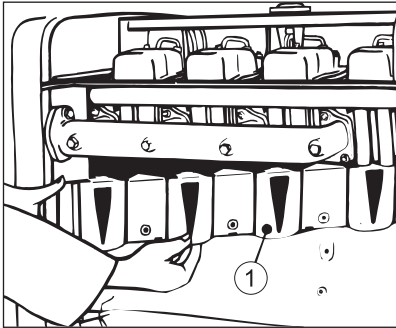
Overview — Preparatory activities

Pos.	Designation
1	Baffle plate

Preparation — Cleaning

Step	Activity
1	<p>On encapsulated engines unscrew the following: (see chapter 5 <i>Engine design, page 26</i>)</p> <ul style="list-style-type: none"> ▪ Hood ▪ Side panel ▪ Cover plate on operating side ▪ Air outlet duct for cooling air ▪ Cover plate on air outlet side
1	<p>Remove the following on engines without a capsule:</p> <ul style="list-style-type: none"> ▪ Side trim panel ▪ Cooling air guide for lubrication oil cooler

Step	Activity
2	Unscrew the baffle plate (1)

Overview — Cleaning

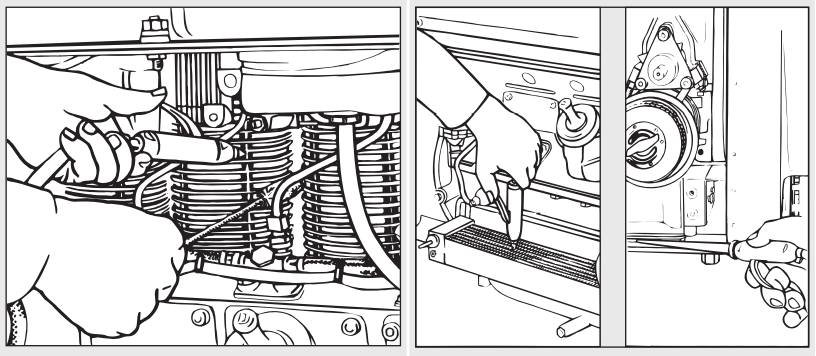

Procedure — Cleaning

Step	Activity
Cleaning in case of dry dirt contamination	
1	Clean the cooling fan, cylinder head and cylinder with a suitable brush.
2	Blow out the entire cooling air area with compressed air.
3	Blow out the oil cooler with compressed air only. <i>NOTE:</i> ▪ Do not place the compressed air gun against the sensitive radiator fins.
4	On encapsulated engines, also clean the area between the floor plate and crankcase.
5	Mount the capsule and air guide parts again.
Cleaning of wet or oily dirt contamination	
1	Disconnect the negative battery terminal.
2	Manually clean the alternator and regulator.
3	Cover the alternator with the installed regulator and do not spray directly.

Step	Activity
4	Spray the entire area with a suitable cleaning solution according to manufacturer instructions and then clean off with a jet of water. Do not spray components of the electrical equipment with a water jet or high pressure jet during cleaning.
5	Blow dry the engine with compressed air.
6	Determine the cause of the oil contamination and have leaks corrected by the HATZ service station .
7	Mount the capsule and air guide parts again.
8	Let the engine run warm to prevent rust formation.

8.2.8 Checking the screw connections

Safety note



NOTICE	
	<ul style="list-style-type: none"> Do not retighten the screws for attaching the cylinder head. The adjustment screws on the speed governor and the injection system are secured with locking varnish and are not permitted to be tightened or adjusted. Only retighten loose screw connections. Screw connections can be secured with thread locking adhesive or tightened to a defined torque. Retightening tight screw connections can cause damage.





Procedure

Step	Activity
1	Check the condition of all screw connections and ensure that they are tight (for exceptions, see note).
2	Tighten any loose screw connections.

8.2.9 Cleaning the screen insert in the exhaust pipe (additional equipment)

Safety notes

 CAUTION	
	<p>Danger of burns.</p> <p>There is a danger of burns when working on a hot engine.</p> <ul style="list-style-type: none"> Let the engine cool before maintenance.

 CAUTION	
 	<p>Danger of injury</p> <p>There is a danger of injury when performing cleaning work at the exhaust screen.</p> <ul style="list-style-type: none"> ▪ Wear safety gloves.
NOTICE	
	<p>Operation of the engine for a lengthy period without a load or with only a small load can result in premature deposits on the screen insert.</p> <p>Shorten the maintenance interval accordingly.</p>

Overview

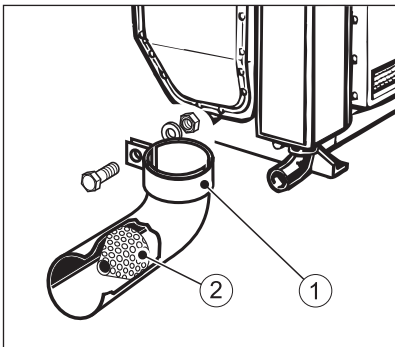









Pos.	Designation
1	Pipe clamp
2	Screen insert

Procedure

Step	Activity
1	Release the pipe clamp (1) and remove it with the exhaust pipe.
2	Remove deposits on the screen insert (2).
3	Check the screen insert for cracks or breakage, and replace if necessary.

8.2.10 Changing the fuel prefilter

Safety notes

 DANGER	
 	<p>Fire hazard from fuel.</p> <p>Leaked or spilled fuel can ignite on hot engine parts and cause serious burn injuries.</p> <ul style="list-style-type: none"> ▪ Never refuel in the vicinity of open flames or sparks that can cause ignition. ▪ Do not smoke. ▪ Do not spill fuel.
 CAUTION	
 	<p>Danger of injury</p> <p>Repeated contact with diesel fuel can cause chapped and cracked skin.</p> <ul style="list-style-type: none"> ▪ Wear safety gloves.
 CAUTION	
	<p>Danger of environmental damage from spilled fuel.</p> <p>When the filter is removed, a small amount of fuel is drained as well.</p> <ul style="list-style-type: none"> ▪ Collect any escaping fuel and dispose of it according to local environmental regulations.
CAUTION	
	<p>Dirt particles can damage the injection system.</p> <ul style="list-style-type: none"> ▪ Maintain clean conditions to ensure dirt does not enter the fuel line.

Overview

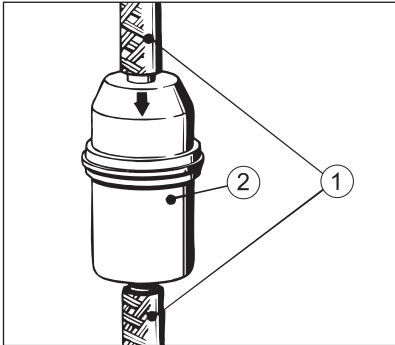

Pos.	Designation
1	Fuel lines
2	Fuel prefilter

Procedure

Step	Activity
1	Place a suitable container under the filter to collect emerging fuel.
2	Close the fuel feed line.
3	Pull the fuel lines (1) off of the fuel prefilter (2) on both sides.
4	Dispose of the old filter in accordance with local environmental regulations.
5	Insert a new fuel prefilter. Note the following: <ul style="list-style-type: none"> ▪ Arrow for flow direction ▪ Position of the fuel tank: HIGH or LOW ▪ Installation position/flow-through direction should be as vertical as possible
6	Open the fuel feed line.
2-4L41C and 2-4M41	
7	To simplify the starting procedure, it is recommended that you pre-pump the fuel using the manual lever at the fuel feed pump until you hear fuel flow back through the return line into the fuel tank (see the chapter 7.3.1 <i>Pumping fuel with the manual lever</i> , page 37).
8	Perform a leak tightness test by activating the manual lever.

Step	Activity
9	After completion, insert the access cover to the fuel feed pump back in the side wall.
4L42C and 4M42	
7	If you have difficulties starting the engine, bleed the injection system with the aid of the manual fuel pump (see the chapter 7.3.2 <i>Pumping fuel with the manual fuel pump, page 38</i>).

8.2.11 Maintaining the dry air filter

NOTICE



- Clean the filter cartridge immediately if, at maximum speed, the combined indicator on the instrument box flashes 14 times.
- The air filter cartridge either needs to be replaced, or cleaned or checked depending on the degree of contamination.
- Renew the filter cartridge after a use period of 500 operating hours.
- Four cylinder engines have two filter cartridges.

Overview of engines 2-4 L41C and 4L42C

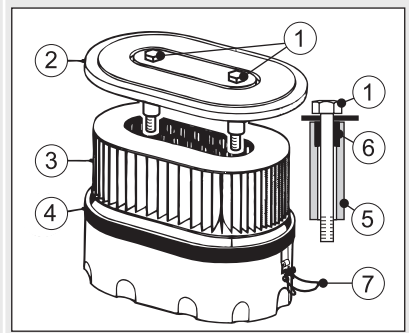
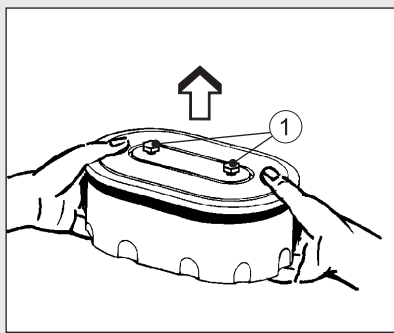

Pos.	Designation
1	Screw
2	Cover
3	Filter cartridge
4	Air filter housing
5	Spacer
6	Bushing

Pos.	Designation
7	Clamp

Removing the air filter cartridge - engines 2-4L41C and 4L42C

Step	Activity
1	Remove the capsule hood.
2	Remove adherent dirt in the area of the air filter housing (4).
3	Only loosen the screws (1) to the point where you can lift off the complete air filter housing (4).
4	Cover the opening in the intake pipe to prevent ingress of dirt and other foreign bodies.
5	On three cylinder engines, open the clamp (7). <ul style="list-style-type: none"> On three cylinder engines, the cover (2) is additionally held by a clamp (7).
6	Open the air filter housing (4).
7	Take out the filter cartridge (3).
8	Clean the air filter housing (4) and cover (2).
9	Renew the bushing (6) if the spacer (5) is loose. <ul style="list-style-type: none"> The spacer (5) is connected with the screw (1) by the elastic bushing (6) to ensure that it cannot fall into the intake pipe during disassembly and assembly.

Overview of the engines 2-4M41. and 4M42

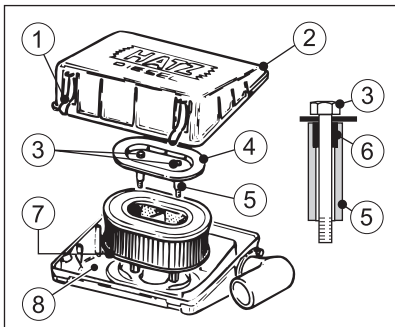

Pos.	Designation
1	Clamp
2	Air filter housing cover
3	Screw



Pos.	Designation
4	Filter cover
5	Spacer
6	Bushing
7	Filter cartridge
8	Air filter housing

Removing the air filter cartridge - engines 2-4M41. and 4M42

Step	Activity
1	Release the clamps (1) and remove the cover of the air filter housing (2).
2	Remove adherent dirt in the air filter area.
3	Only loosen the screws (3) to the point where the filter cover (4) can be removed with the filter cartridge (7).
4	Cover the opening in the intake pipe to prevent ingress of dirt and other foreign bodies.
5	Clean the air filter housing cover (2), filter cover (4) and air filter housing (8).
6	<p>Renew the bushing (6) if the spacer (5) is loose.</p> <ul style="list-style-type: none"> The spacer (5) is connected with the screw (3) by the elastic bushing (6) to ensure that it cannot fall into the intake pipe during disassembly and assembly.

8.2.12 Checking and cleaning the air filter cartridge

Safety notes

 CAUTION	
 	<p>Danger of injury.</p> <p>When working with compressed air, foreign bodies may fly into your eyes.</p> <ul style="list-style-type: none"> Wear safety goggles. Never direct the compressed air jet toward people or toward yourself.

NOTICE

- The pressure must not exceed 5 bar.
- A distance of approx. 150 mm must be maintained between the filter cartridge and the compressed air gun.
- The filter cartridge may not be washed out or beaten out.
- Even minor damage in the areas of the sealing surface, filter paper or filter cartridge makes it impossible to reuse the filter cartridge.

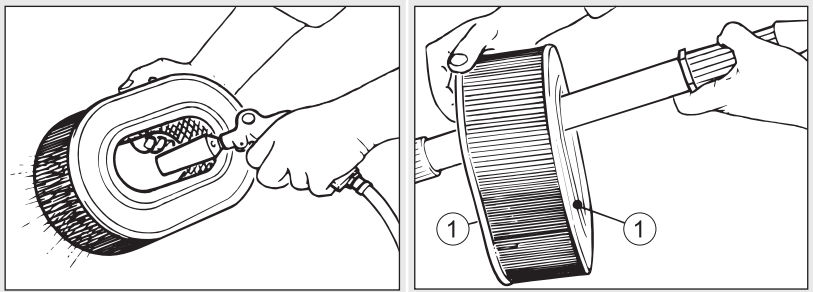
Overview — Checking/cleaning the air filter cartridge

Pos.	Designation
1	Sealing surface

Step	Activity
------	----------

Dry contamination

1	Blow out the filter cartridge with dry compressed air from the inside to the outside until dust no longer emerges.
2	Check the sealing surfaces (2) of the filter cartridge for damage.
3	Check the filter cartridge for cracks in the filter paper and other damage by holding it against the light at a slant or letting light from a lamp shine through it.
4	Replace the filter cartridge if necessary (see note).

Moist or oily contamination

1	Renew the filter cartridge.
---	-----------------------------

Mechanical air filter maintenance display

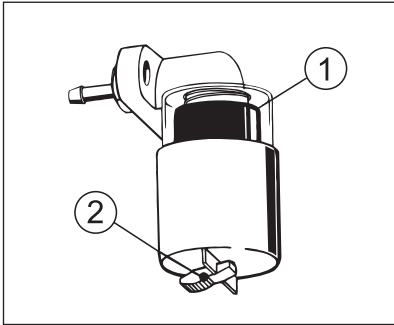





Pos.	Designation
1	Red field
2	Reset button

Procedure — Mounting the air filter cartridge

Step	Activity
1	When assembling, mount the parts individually one after the other to make sure they are correctly seated and to ensure leak tightness.
2	After the filter is mounted, unlock the visible red field (1) in the maintenance display by pressing the reset button (2).

8.2.13 Check and set the tappet clearance

Safety notes

 CAUTION	
	<p>Danger of burns.</p> <p>There is a danger of burns when working on a hot engine. Only perform the settings while the engine is cold (10-30°C).</p> <ul style="list-style-type: none"> Let the engine cool.
 CAUTION	
	<p>Damage from inadequate engine cooling.</p> <p>Only operate the engine when all covers are installed.</p>

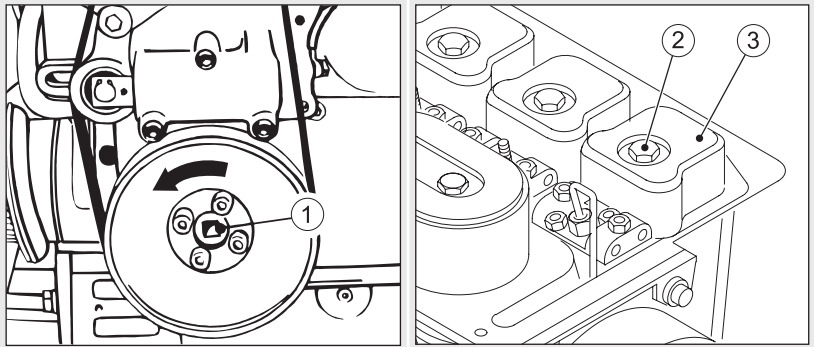
Overview — Preparatory activities

Pos.	Designation
1	Square opening
2	Hex nut
3	Cylinder head cover

Preparation — Adjusting the tappet clearance

Step	Activity
1	On encapsulated engines, remove the hood of the capsule (see chapter 5 <i>Engine design</i> , page 26).
2	Remove the hex nut (2) and remove the cylinder head cover (3).
3	Remove the air guide housing cover (see chapter 5 <i>Engine design</i> , page 26) and belt guard.
4	Insert the ratchet or T-piece 1/2" with the required extension (1) into the square opening.

NOTICE**Turn the engine in the sense of rotation.**

Anti-clockwise in both cases - flywheel side or timing cover side.

Numbering of the valves and cylinders from the fan side

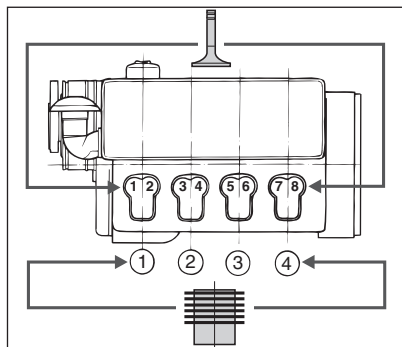

Setting method for two cylinder engine

Step	Activity
1	Set the valve of the 1st cylinder – fan side – to overlap (outlet valve not yet closed, intake valve begins to open).
2	Turn the crankshaft by 180° in the sense of rotation and check the valves of the 2nd cylinder.
3	Continue turning the crankshaft by 180° in the sense of rotation and check the valves of the first cylinder.

Setting method for three and four cylinder engines

Type	Valve no. ... fully opened	Check the valves of the ... cylinder
3-cylinder	1	3rd cylinder
	5	2nd cylinder
	3	1st cylinder
4-cylinder	1	3rd cylinder
	5	4th cylinder
	7	2nd cylinder
	3	1st cylinder

Overview — Adjusting the tappet clearance

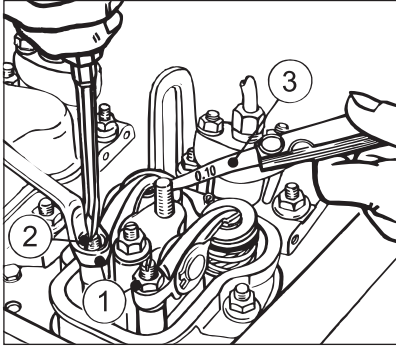

Pos.	Designation
1	Hex nut
2	Adjusting screw
3	Feeler gauge



Procedure — Adjusting the tappet clearance

Step	Activity
1	Check the tappet clearance with the feeler gauge (3). For the setting, see the chapter 4 <i>Technical data</i> , page 22
2	If the tappet clearance needs to be corrected: <ul style="list-style-type: none"> ▪ Release the hex nut (1). ▪ Turn the adjustment screw (2) so the feeler gauge (3) can be pulled through with a barely perceptible resistance after the hex nut (1) is tightened again.
3	Repeat the above procedure for the entire valve area, taking special care to use the described adjustment method.
4	Mount the cylinder head cover again: <ul style="list-style-type: none"> ▪ Always renew the gaskets. ▪ Use the fixing nuts for the cylinder head cover no more than twice before renewing them. ▪ Tightening torque: 10 Nm.
5	Mount all covers. <i>NOTE:</i> <ul style="list-style-type: none"> ▪ Under no circumstances is the engine permitted to be operated if not all covers are mounted.

Step	Activity
6	After a brief trial run, check the cylinder head cover for tightness.

8.2.14 Changing the oil filter

Safety note

 CAUTION	
 	<p>Danger of burns.</p> <p>When working on the engine there is a danger of burns from hot oil.</p> <ul style="list-style-type: none"> ▪ Wear personal protective equipment (gloves). ▪ Collect the used oil and dispose of it according to local environmental regulations.

Overview

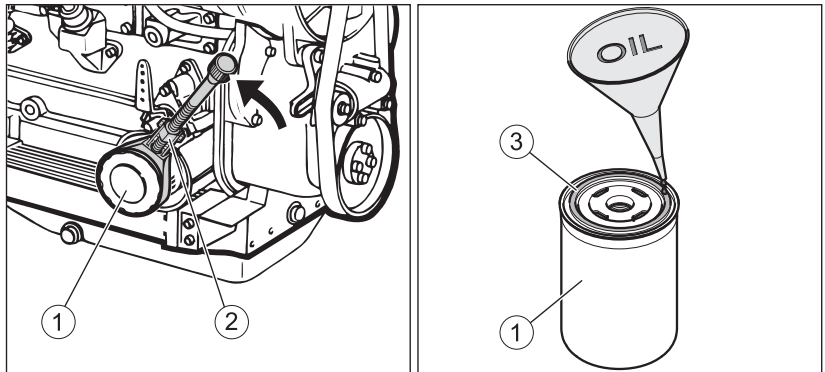

1	Oil filter
2	Strap wrench
3	Gasket







Procedure

Step	Activity
1	Release the oil filter (1) with a strap wrench (2) and quickly unscrew it or pull it out. <ul style="list-style-type: none"> ▪ HATZ order no. for strap wrench: 620 307 01.
2	Dispose of the old filter in accordance with local environmental regulations.

Step	Activity
3	Wipe spilled engine oil out of the oil baffle.
4	Lightly oil the gasket (3) of the new oil filter.
5	Screw in the oil filter and tighten it by hand.
6	Add engine oil to the max. mark on the dipstick. <ul style="list-style-type: none"> ▪ For the specification and viscosity, see chapter 4.3 <i>Engine oil</i>, page 25. ▪ The mark on the dipstick indicates whether the engine is equipped with an oil sump or not (see chapter 4.1 <i>Engine</i>, page 23).
7	Reinsert the dipstick.
8	Check the oil level after a short test run and correct if necessary.
9	Check the oil filter for tightness and retighten by hand if necessary.

8.2.15 Change the main fuel filter

Safety notes

 DANGER	
 	<p>Fire hazard from fuel</p> <p>Leaked or spilled fuel can ignite on hot engine parts and cause serious burn injuries.</p> <ul style="list-style-type: none"> ▪ Do not spill fuel. ▪ No open flames when working on the fuel system. ▪ Do not smoke.
 CAUTION	
 	<p>Danger of injury</p> <p>Repeated contact with diesel fuel can cause chapped and cracked skin.</p> <ul style="list-style-type: none"> ▪ Wear safety gloves.

**CAUTION****Danger of environmental damage from spilled fuel.**

When the filter is removed, a small amount of fuel is drained as well.

- Collect any escaping fuel and dispose of it according to local environmental regulations.

CAUTION**Dirt particles can damage the injection system.**

- Maintain clean conditions to ensure dirt does not enter the fuel line.

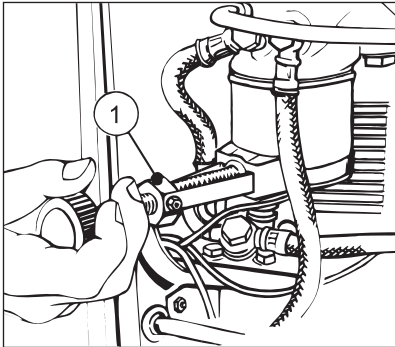
Overview 2-4L41C and 2-4M41.

Pos.	Designation
1	Strap wrench (HATZ order no.: 620 307 01)

Step	Activity
1	On encapsulated engines: <ul style="list-style-type: none"> ▪ Lift off the capsule hood (see the chapter <i>5 Engine design, page 26</i>).
	On engines without a capsule: <ul style="list-style-type: none"> ▪ Remove the side trim panel (see the chapter <i>5 Engine design, page 26</i>).
2	Place a suitable container under the filter to collect emerging fuel.
3	Close the fuel feed line.

Step	Activity
4	Slide on the strap wrench (1) and unscrew the fuel filter counter-clockwise.
5	Dispose of the old filter in accordance with local environmental regulations.
6	Lightly oil the gasket of the new fuel filter.
7	Mount the fuel filter and tighten it by hand .
8	Open the fuel feed line.
9	To simplify the starting procedure, it is recommended that you pre-pump the fuel using the manual lever at the fuel feed pump until you hear fuel flow back through the return line into the fuel tank (see the chapter 7.3.1 <i>Pumping fuel with the manual lever</i> , page 37).
10	Perform a leak tightness test by activating the manual lever.
11	After completion, insert the access cover to the fuel feed pump back in the side wall.
12	Mount the capsule and air guide parts again.

Overview 4L42C and 4M42

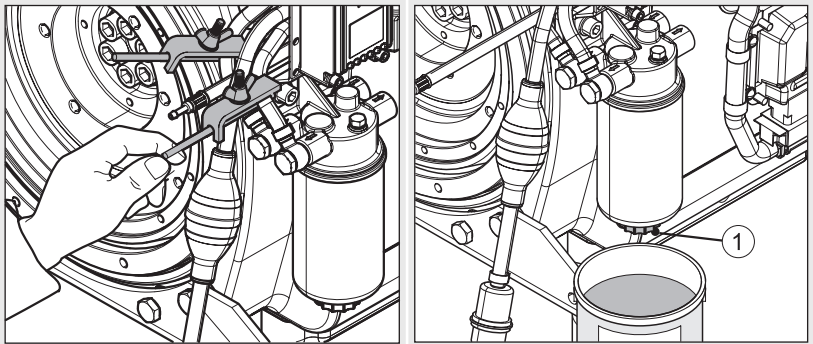

Pos.	Designation
1	Drain plug

Preparation 4L42C and 4M42

Step	Activity
1	Close the fuel lines on the filter housing.
2	Place a suitable container under the filter to collect emerging fuel.

Step	Activity
3	Release the drain screw (1) and drain the fuel.

Overview 4L42C and 4M42

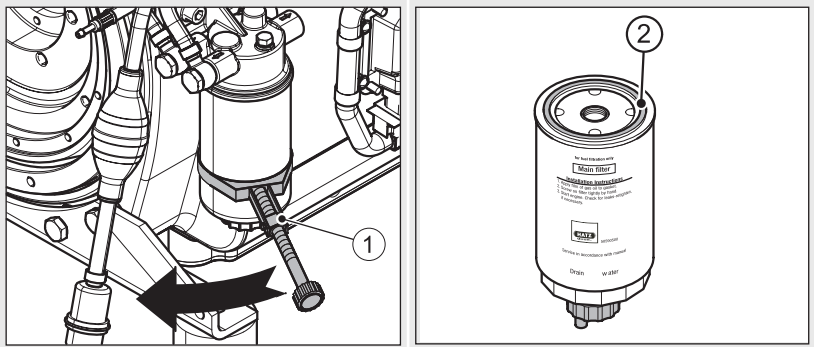

Pos.	Designation
1	Strap wrench (HATZ order no.: 620 307 01)
2	Gasket

Procedure 4L42 C and 4M42

Step	Activity
1	Slide on the strap wrench (1) and unscrew the fuel filter counter-clockwise.
2	Dispose of the old filter in accordance with local environmental regulations.
3	Lightly oil the gasket (2) of the new fuel filter.
4	Mount the fuel filter and tighten it by hand .
5	Open the fuel feed line.
6	Bleed the injection system with the aid of the manual fuel pump (see the chapter 7.3.2 <i>Pumping fuel with the manual fuel pump</i> , page 38).
7	After a brief trial run, check the fuel filter for leak tightness and retighten by hand.

8.2.16 Checking that the air filter maintenance indicator is working properly

Overview

Electrical
air filter maintenance display

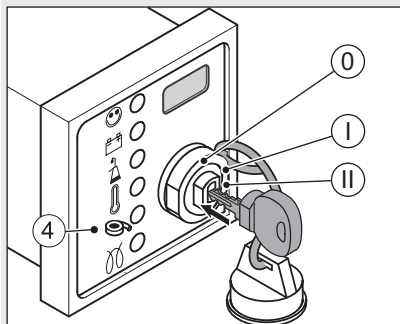

Mechanical
air filter maintenance display

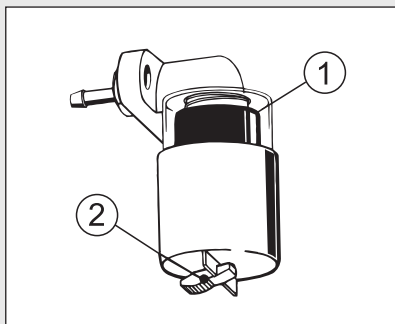

Hose of air intake pipe

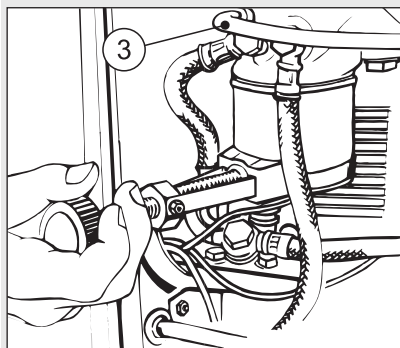

Pos.	Designation
1	Red field
2	Reset button
3	Hose
4	Air filter maintenance display

Ignition lock

0	Off
I	Operation
II	Start

Procedure

Step	Activity
1	Remove the capsule hood or side trim panel (see chapter 5 <i>Engine design, page 26</i>).
2	Turn the starting key to position I.
3	Pull the hose (3) off of the exhaust manifold.
Electrical air filter maintenance display	
	<i>NOTE:</i> On engine types 4L42 and 4M42 , this function test cannot be performed.
4	Generate a vacuum by sucking forcefully at the hose end. The indicator (4) lights up.
5	If there is no reaction, check the following: <ul style="list-style-type: none"> ▪ Electrical part; cable connections, etc. ▪ Indicator ▪ Function of the maintenance switch.
Mechanical air filter maintenance display	
4	Generate a vacuum by sucking forcefully at the hose end. The red field (1) engages.
5	After the function test, unlock the red field (1) by pressing the re-set button (2).
After the function test	
6	Replace the faulty parts.
7	Reattach the hose (3) of the exhaust manifold.
8	Mount the capsule and air guide parts again.

8.2.17 Renewing the poly v belt and checking the function of the switch-off unit

NOTICE



When changing the belt:

- Always check the function of the switch-off unit. The switch-off pin must emerge by spring force, or else the machine will not switch off automatically if the belt tears.
- If the grooves are broken off or bent, renew the damaged pulley.
- To be absolutely sure that you order the right poly v belt – in terms of the length – it is recommended that you measure the diameter of the fan-side pulley and use this as the basis for your selection.

Belt types

Because of the different diameters of the fan-side pulleys, in combination with different engine types and versions, various lengths of poly v belts are used.

Type and engine version	ID number	Belt length mm	Fan pulley Ø mm
2L41C	502 031 00	920	72
All remaining types and versions	501 415 00	910	64

Overview — Removing the poly v belt

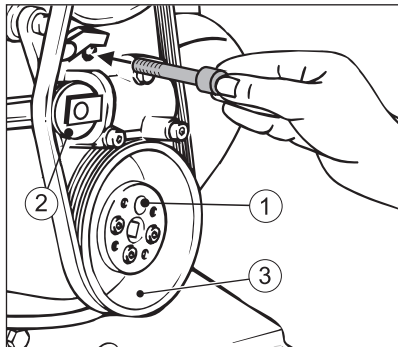

Pos.	Designation
1	Cylinder screw
2	Tension pulley
3	Pulley

Procedure — Removing the poly v belt

Step	Activity
1	Unscrew one cylinder screw (1) from the pulley (3).
2	Push back the tension pulley (2) and lock it using the cylinder screw (1).
3	Unscrew the pulley (3).
4	Check the pulley (3) for broken or bent grooves.
5	Remove the poly v belt.

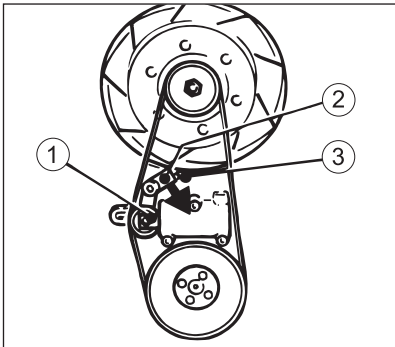
Overview — Checking the function of the switch-off unit of the belt monitoring system

Pos.	Designation
1	Tension pulley
2	Angle lever
3	Switch-off pin

Procedure — Checking the function of the switch-off unit of the belt monitoring system

Step	Activity
1	<p>Release the piston with the tension pulley (1) by removing the cylinder screw.</p> <ul style="list-style-type: none"> ▪ The piston with the tension pulley is pushed out of the housing by spring pressure. ▪ The angle lever (2) turns downward and releases the switch-off pin (3). ▪ The switch-off pin (3) must emerge by spring force, or else the machine will not switch off automatically if the belt tears.

Step	Activity
2	If there is no reaction, please contact the nearest HATZ service station .

Overview — Mounting the poly v belt

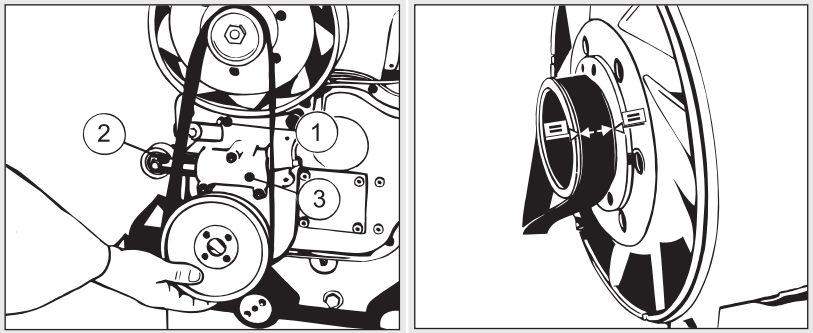

Pos.	Designation
1	Switch-off pin
2	Tension pulley
3	Housing

Procedure — Mounting the poly v belt

Step	Activity
1	Slide in the switch-off pin (1).
2	Slide the piston with the tension pulley (2) into the housing (3) and lock it using the cylinder screw.
3	Position the poly v belt centrally on the pulley of the fan wheel, the tension pulley (2) and the pulley at the bottom.

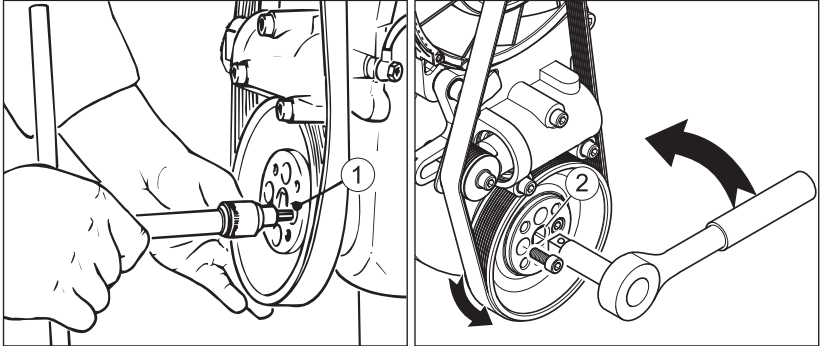
Overview — Centering the pulley

Pos.	Designation
1	Cylinder screw
2	Square opening

Procedure — Centering the pulley

Step	Activity
1	Lightly secure the pulley with a cylinder screw (1) without placing the pulley fully on the centering.
2	Insert the ratchet or T-piece 1/2" with the required extension into the square opening (2).
3	Turn the pulley until a further cylinder screw can be fitted.
4	Insert the remaining cylinder screws and tighten all screws.