

BA367E-SS Rugged one input Intrinsically safe Counter

Issue 3

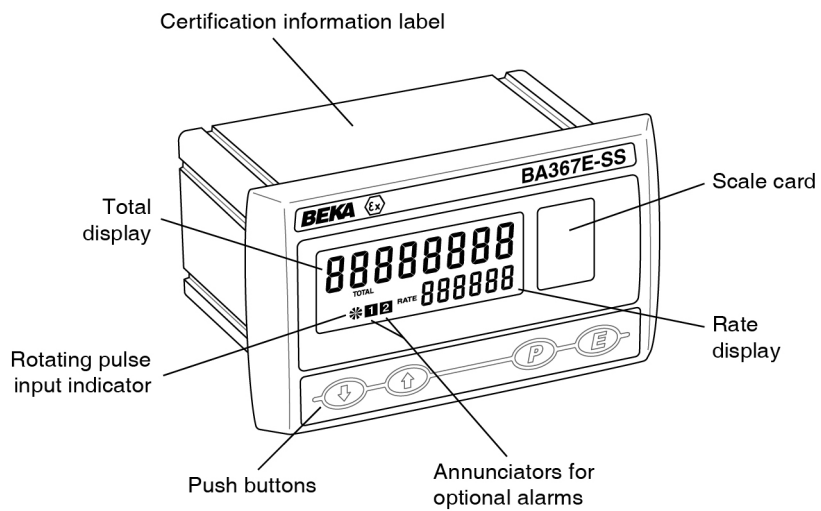

CONTENTS

1. Description

2. Operation

- 2.1 Initialisation
- 2.2 Controls
- 2.3 Displays

3. Intrinsic Safety Certification

- 3.1 ATEX gas certification
- 3.2 Zones, gas groups & T rating
- 3.3 Special conditions for safe use
- 3.4 Power supply
- 3.5 Pulse input terminals
 - 3.5.1 sensors that do not require energising.
 - 3.5.2 sensors that do require energising.
- 3.6 Remote reset terminals
- 3.7 Certification label information

4. System Design for Hazardous Areas

- 4.1 Use with Zener barriers
 - 4.1.1 Power supply
 - 4.1.2 Pulse input
 - 4.1.3 Switch contact input
 - 4.1.4 2-wire proximity detector input
 - 4.1.5 Open collector input
 - 4.1.6 Magnetic pick-off input
 - 4.1.7 Voltage pulse input
 - 4.1.8 Remote reset
- 4.2 Use with galvanic isolators
 - 4.2.1 Power supply
 - 4.2.2 Pulse input
 - 4.2.3 Switch contact input
 - 4.2.4 2-wire proximity detector input
 - 4.2.5 Open collector input
 - 4.2.6 Magnetic pick-off input
 - 4.2.7 Voltage pulse input
 - 4.2.8 Remote reset
- 4.3 Use in Ex e or Ex p panel enclosure located in Zones 1 or 2.
 - 4.3.1 Installation in Ex e panel enclosure
 - 4.3.2 Installation in Ex p panel enclosure

5. Installation

- 5.1 Location
- 5.2 Installation procedure
- 5.3 EMC
- 5.4 Counter earthing
- 5.5 Scale card

6. Configuration and Calibration

- 6.1 Configuration structure
- 6.2 Accessing the configuration functions
- 6.3 Summary of configuration functions
- 6.4 Input: i_{nPE}
- 6.5 Input type: i_{nPEYPE}
- 6.6 Input debounce: $dEBouNCE$
- 6.7 Input pulse counting edge: $ENt EdGE$
- 6.8 Display update interval: $uPdREtE$
- 6.9 Upper display: $d1 SP-1$
- 6.10 Lower display: $d1 SP-2$
- 6.11 Position of the decimal points: dP
- 6.12 Total scale factor: $SCALEt$
- 6.13 Rate scale factor: $SCALE.r$
- 6.14 Timebase: $t-bASE$
- 6.15 Display filter: $F1 LLEr$
- 6.16 Direction of count: $uP or dn$
- 6.17 Reset value: $CLR URL$
- 6.18 Local reset: $LoC CLR$
- 6.19 Local total reset: $CLR tOt$
- 6.20 Local grand total reset: $CLR GtOt$
- 6.21 Reset grand total from configuration menu: $CLR GtOt$
- 6.22 Security code: $CoDE$
- 6.23 Reset configuration to factory defaults: $rSEt dEF$
- 6.24 Display overflow

7. Configuration example

8. Maintenance

- 8.1 Fault finding during commissioning
- 8.2 Fault finding after commissioning
- 8.3 Servicing
- 8.4 Routine maintenance
- 8.5 Guarantee
- 8.6 Customer comments

CONTENTS CONTINUED

9. Accessories

9.1 Scale card

9.2 Tag information

9.3 Alarms

- 9.3.1 Solid state output
- 9.3.2 Intrinsic safety
- 9.3.3 Configuration summary
- 9.3.4 Alarm enable: *EnbL*
- 9.3.5 Type of alarm: *tYPPE*
- 9.3.6 Setpoint adjustment:
SPix & SP2x
- 9.3.7 Alarm function: *HiLo*
- 9.3.8 Alarm output status: *no.nL*
- 9.3.9 Hysteresis: *H5Er*
- 9.3.10 Alarm delay: *dELR*
- 9.3.11 Alarm silence time: *SiL*
- 9.3.12 Flash display when alarm occurs:
FL5H
- 9.3.13 Access Setpoint: *RE5P*
- 9.3.14 Adjusting alarm setpoints from
display mode.

9.4 Pulse Output

- 9.4.1 Intrinsic safety
- 9.4.2 System design
- 9.4.3 Configuration
- 9.4.4 Access Pulse output sub-menu:
PuL5E oP
- 9.4.5 Enable pulse output: *EnbL*
- 9.4.6 Source of pulse output: *SourceEE*
- 9.4.7 Divide output pulse frequency:
diU, dE
- 9.4.8 Output pulse width: *durRt, on*

9.5 4/20mA output

- 9.5.1 Intrinsic safety
- 9.5.2 System design
- 9.5.3 Configuration
- 9.5.4 Access 4/20mA output
sub-menu: *4-20 oP*
- 9.5.5 Enable 4/20mA output: *EnbL*
- 9.5.6 Select rate or total source:
4-20tYPE
- 9.5.7 Display corresponding to
4mA output: *4.000*
- 9.5.8 Display corresponding to
20mA output: *20.000*

9.6 Display backlight

- Appendix 1** Dust certification
- Appendix 2** IECEx certification
- Appendix 3** ETL and cETL certification

1. DESCRIPTION

This rugged intrinsically safe, one input Counter may be configured to count input pulses from a wide variety of sensors and to display the total number in engineering units. A smaller five digit display may be activated to show the input pulse rate in engineering units per second, minute or per hour.

This instruction manual supplements the abbreviated instruction sheet supplied with each instrument.

The BA367E-SS has been certified intrinsically safe for use in gas and dust hazardous areas by Notified Body Intertek Testing and Certification Ltd and complies with the European ATEX Directive 2014/34/EU. It has a rugged stainless steel enclosure and an impact resistant glass window. In addition to normal intrinsically safe applications, the certification allows it to be installed in an Ex e, Ex n, Ex p or Ex t panel enclosure without invalidating the enclosure's certification.

For international applications the BA367E-SS also has IECEx certification which is described in Appendix 2.

For US and Canadian applications the BA367E-SS has ETL and cETL, see Appendix 3.

2. OPERATION

Fig 1 shows a simplified block diagram of the BA367E-SS Counter. The instrument can be supplied with a factory fitted internally powered display backlight, plus one of the following three factory fitted accessories:

- Dual isolated alarms
- or** Isolated pulse output
- or** Isolated 4/20mA output

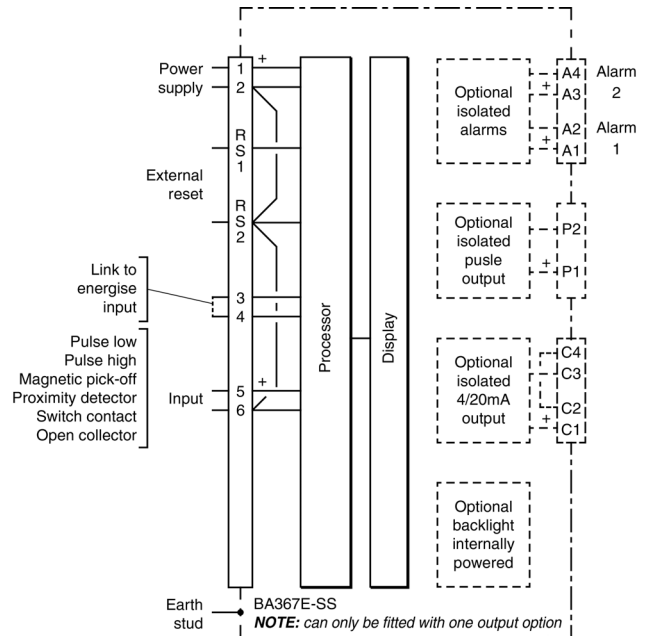

Fig 1 BA367E-SS block diagram

2.1 Initialisation

Each time power is applied to a BA367E-SS Counter initialisation is performed. After a short delay the following display sequence occurs:

All segments of the display are activated

Counter starts functioning, using the configuration information stored in the instrument's permanent memory. Unless total and grand total displays have been reset to zero, new pulses will be added to the existing totals.

2.2 Controls

The BA367E-SS Counter is controlled and configured via four front panel push buttons. In the display mode i.e. when the instrument is counting, the push button functions are:

Push Button Functions

- [P] + [E]** Access to configuration menu
- [▼] + [▲]** If Local Total Reset [Lr Tot] in the instrument configuration menu has been activated, operating the [▼] and [▲] buttons simultaneously for three seconds will reset the total display to zero and clear any pulses stored in the optional pulse output.
See 6.19
- [E] + [▼]** Grand total - shows L₀ followed by least significant 8 digits of the 16 digit grand total.
- [E] + [▲]** Grand total - shows H₁ followed by the most significant 8 digits of the 16 digit grand total.
If Local Grand Total Reset [Lr Gtot] in the instrument configuration menu has been activated, operating the [E] and [▲] buttons simultaneously for ten seconds will result in [Lr.n₀] being displayed with the n₀ flashing. Operating the [▲] or [▼] button will change the display to [Lr.4E5], the [E] button will then reset the grand total to zero which will be confirmed by a brief display of [Lr d]. See 6.20
- [P] + [▼]** Shows firmware version

Note: When optional alarms are fitted, the BA367E-SS Counter may be configured to provide direct access to the alarm setpoints from the display mode when the [P] and [▲] buttons are operated simultaneously. See 9.3.13 and 9.3.14

2.3 Displays

The BA367E-SS Counter has two digital displays and associated annunciators, plus a pulse input indicator as shown on the front page of this manual.

Total display Shows the total pulse count on the upper eight digit display. May be reset to zero via front panel push buttons or by a remote reset switch.

Rate Display Shows the pulse rate on the lower six digit display. Total and rate displays may be reversed.

Pulse input indicator This disc in the lower left hand corner of the display 'rotates' for two seconds each time an input pulse is received on either input. Appears to rotate continuously when combined input frequency on both inputs exceeds 0.5Hz.

Reset annunciator Activated while the total display is being reset via the front panel push buttons, or the external reset terminals.

Rate annunciator Identifies rate display

Total annunciator Identifies total display

3. INTRINSIC SAFETY CERTIFICATION

The BA367E-SS Counter has ATEX and IECEx gas and dust certification. This section of the instruction manual describes ATEX gas certification, dust, IECEx and other approvals are each described in separate appendixes to this manual.

3.1 ATEX gas certification

Notified Body Intertek Testing and Certification Ltd have issued the BA367E-SS with an EC-Type Examination Certificate number ITS16ATEX28408X. This confirms compliance with harmonised European standards and it has been used to confirm compliance with the European ATEX Directive for Group II, Category 1G equipment. The Counter carries the community mark and subject to local codes of practice may be installed in any of the European Economic Area (EEA) member countries. ATEX certificates are also acceptable for installations in Switzerland.

This section of the instruction manual describes ATEX installations in explosive gas atmospheres conforming with EN60079-14 Electrical installations design, selection and erection. When designing systems for installation outside the UK the local Code of Practice should be consulted.

3.2 Zones, gas groups and T rating

The BA367E-SS Counter has been certified Ex ia IIC T5 Ga. When connected to a suitable system it may be installed in:

- Zone 0 explosive gas air mixture continuously present.
- Zone 1 explosive gas air mixture likely to occur in normal operation.
- Zone 2 explosive gas air mixture not likely to occur, and if it does will only exist for a short time.

Be used with gases in groups:

- Group A propane
- Group B ethylene
- Group C hydrogen

Having a temperature classification of:

- T1 450°C
- T2 300°C
- T3 200°C
- T4 135°C
- T5 100°C

At ambient temperatures between:

- 40 to +60°C When installed as an intrinsically safe Ex i instrument in an Ex e, Ex n, Ex p or Ex t enclosure.
- 40 to +70°C When used as an intrinsically safe Ex i instrument not in an Ex e, Ex n, Ex p or Ex t enclosure.

3.3 Special conditions for safe use

The ATEX intrinsic safety certificate number has an 'X' suffix indicating that for some applications special conditions apply for safe use.

When installed in an Ex e, Ex n, Ex p or Ex t panel enclosure all connections to the BA367E-SS must be made by appropriately rated Zener barriers or galvanic isolators.

This means that when installed in an Ex e, Ex n, Ex p or Ex t panel enclosure the BA367E-SS remains an intrinsically safe instrument and must comply with the installation requirements shown in this manual.

The certificate also states:

The front of the stainless steel enclosure complies with the requirements for Ex e, Ex n Ex p & Ex t type of protection.

Therefore when correctly installed the BA367E-SS Counter will not invalidate the Ex e, Ex n, Ex p or Ex t panel enclosure certification.

Note: At temperatures below -20°C the instrument will continue to function, but the display response will become slower and the contrast will be reduced.

3.4 Power supply

When installed in a hazardous area the BA367E-SS Counter should be powered via a certified Zener barrier or galvanic isolator from a dc supply located in the safe area or from associated apparatus with an intrinsically safe output.

The input safety parameters of terminals 1 and 2 are:

$$\begin{aligned} U_i &= 28\text{V dc} \\ I_i &= 200\text{mA dc} \\ P_i &= 0.84\text{W} \end{aligned}$$

Any certified Zener barrier or galvanic isolator with output safety parameters equal to or less than these limits may be used.

The maximum equivalent capacitance and inductance between terminals 1 and 2 is:

$$\begin{aligned} C_i &= 2\text{nF} \\ L_i &= 4\mu\text{H} \end{aligned}$$

To determine the maximum permissible cable parameters the above figures, which are small and may be ignored in many applications, should be subtracted from the maximum permitted cable parameters specified for the Zener barrier or galvanic isolator powering the BA367E-SS Counter.

3.5 Pulse input terminals

The BA367E-SS pulse input is a separate intrinsically safe circuit with the negative terminal internally connected to the negative side of the power supply terminal 2 and to the reset terminal RS2. See Fig 1.

Some types of sensor that may be connected to the BA367E-SS input, such as a switch contact or a 2-wire proximity detector, require energising to determine their state. For sensors requiring energising fitting an external link between terminals 3 & 4 of the BA367E-SS connects an internal 7V, 6mA supply to the input. Energising is not required when the BA367E-SS input is connected to a voltage source.

Fitting a link changes the output safety parameters of the BA367E-SS Counter pulse input as shown in the following table which also shows which types of sensor require energising (link fitting).

Type of input	Link 3 & 4	Safety parameters		
		U _o	I _o	P _o
Switch contact	Yes	10.5V	8.2mA	25mW
Proximity detector	Yes	10.5V	8.2mA	25mW
Open collector	Yes	10.5V	8.2mA	25mW
Magnetic pick-off	No	1V	11µA	3µW
Voltage input (low)	No	1V	11µA	3µW
Voltage input (high)	No	1V	11µA	3µW

3.5.1 Sensors that do not require energising

Magnetic pick-offs and voltage pulse inputs do not require energising, see section 3.5. For intrinsic safety purposes, sources of energy with output parameters less than 1.5V; 100mA and 25mW are considered to be *simple apparatus* (Clause 5.7 of EN60079-11), which allows them to be ignored and not documented when assessing an intrinsic safe system.

When terminals 3 & 4 are not linked, the BA367E-SS Counter input terminals comply with the requirements for *simple apparatus*, thus allowing the output parameters to be ignored when assessing the safety of the sensor connected to the input.

This allows almost any certified intrinsically safe voltage pulse circuit or certified magnetic pick-off to be directly connected to the BA367E-SS Counter input providing that:

- a. The output parameters of the sensor or circuit are equal to or less than:

$$\begin{aligned} U_o &\leq 28\text{V dc} \\ I_o &\leq 200\text{mA dc} \\ P_o &\leq 0.84\text{W} \end{aligned}$$

- b. The sensor and associated wiring can withstand a 500V rms insulation test to earth. The BA367E-SS EC-Type Examination Certificate specifies that the equivalent capacitance and inductance of the BA367E-SS Counter input is:

$$\begin{aligned} C_i &= 2\text{nF} \\ L_i &= 4\mu\text{H} \end{aligned}$$

To determine the maximum permissible cable parameters these figures should be subtracted from the maximum permitted cable parameters specified for the sensor or circuit connected to the input terminals of the Counter. These input parameters are very small and are therefore unlikely to make any significant difference to the allowable cable parameters.

- c. The sensor is located in the same hazardous area as the BA367E-SS.

3.5.2 sensors that require energising

Switch contacts, proximity detector or open collector inputs require energising which is achieved by linking Counter terminals 3 and 4 together as described in section 3.5. When energised, the output parameters of the pulse input terminals 5 and 6 are:

$$\begin{aligned}U_o &= 10.5V \text{ dc} \\I_o &= 9.2mA \text{ dc} \\P_o &= 24mW\end{aligned}$$

These output parameters do not comply with the requirements for *simple apparatus* and should be considered when assessing the safety of the sensor connected to the totaliser pulse input.

Any certified intrinsically safe sensor may be connected to a BA367E-SS energised input providing that:

- a. The sensor is a certified intrinsically safe device having input parameters equal to or greater than:

$$\begin{aligned}U_i &\geq 10.5V \text{ dc} \\I_i &\geq 9.2mA \text{ dc} \\P_i &\geq 24mW\end{aligned}$$

or complies with the requirements for *simple apparatus*.

- b. The sensor and associated wiring can withstand a 500V rms insulation test to earth.
- c. The sensor is located in the same hazardous area as the BA367E-SS.
- d. Minimum operating voltage of a sensor incorporating a NAMUR compliant proximity detector is less than 7.5V.

3.6 Remote reset terminals

The BA367E-SS Counter may be reset to zero or to the reset value by connecting the reset terminals RS1 and RS2 together for more than one second. These two terminals have the following input and output safety parameters:

$$\begin{aligned}U_o &= 3.8V \text{ dc} \\I_o &= 1.6mA \text{ dc} \\P_o &= 2.0mW\end{aligned}$$

$$\begin{aligned}U_i &= 28V \text{ dc} \\I_i &= 200mA \text{ dc} \\P_i &= 0.84W\end{aligned}$$



The equivalent capacitance and inductance between them is:

$$\begin{aligned}C_i &= 0nF \\L_i &= 0\mu H\end{aligned}$$

The maximum capacitance and inductance that may be safely connected between the reset terminals RS1 and RS2 is:

$$\begin{aligned}C_o &= 40\mu F \\L_o &= 1H\end{aligned}$$

The Counter's total display may be reset from within the hazardous area by any mechanically operated switch connected directly to terminals RS1 and RS2. To reset the total display from the safe area a Zener barrier or intrinsically safe relay is required to transfer the contact closure into the hazardous area. Almost any intrinsically safe relay with certification permitting the contacts to be connected to equipment in the hazardous area may be used. A diode return Zener barrier is not suitable for this application.

Alternatively, the BA367E-SS Counter may be configured so that the total display is reset to zero when the  and  push buttons are operated simultaneously for more than two seconds. See 6.19.

3.7 Certification label information

The certification information label is fitted in a recess on the top outer surface of the enclosure. It shows the ATEX and IECEx certification information plus BEKA associates name and location and the instrument serial number. Non European certification information may also be included.



BA367E-SS Certification information label

4. SYSTEM DESIGN FOR HAZARDOUS AREAS

4.1 Use with Zener barriers

Zener barriers are the least expensive intrinsically safe interface between a safe and hazardous area. However they require a high integrity earth connection that may be expensive to install and they do not provide isolation. When a high integrity earth connection is not already available, it may be less expensive and complicated to use galvanic isolators for the installation of a single BA367E-SS Counter.

Terminals 2, 6 and RS2 of the BA367E-SS Counter are internally connected together. If any of these terminals are earthed, as shown in Figs 2 & 3, the other common terminals should only be connected to the same earth, i.e. the barrier busbar, or to circuits that have 500V insulation to earth.

Any certified Zener barrier may be used with the BA367E-SS Counter providing it's output parameters do not exceed the input parameters of the terminals to which it is connected. Only one polarity of Zener barrier i.e. positive or negative, may be used in a Counter system.

Fig 2 illustrates the basic circuit that is used for all BA367E-SS Counter installations protected by Zener barriers. For simplicity, connections for the optional alarms, pulse output and 4/20mA output are shown separately in section 9 this manual.

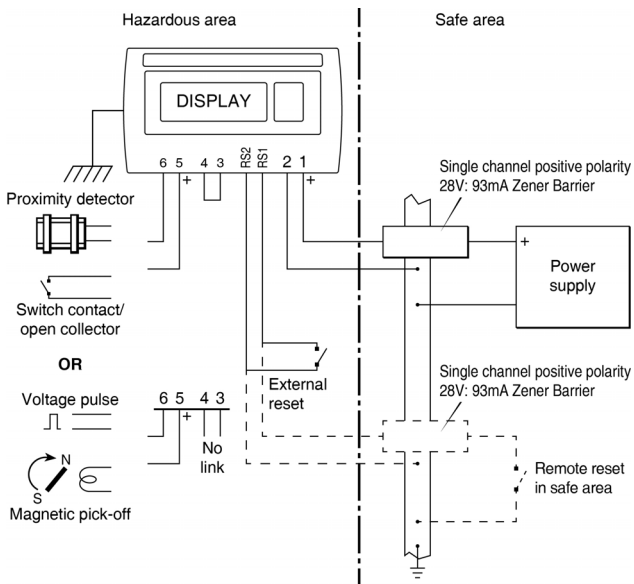

Fig 2 BA367E-SS used with Zener barriers

Alternatively the pulse input source may be located in the safe area. Fig 3 shows how an additional Zener barrier is used to transfer the signal to the Counter in the hazardous area. When more than one Zener barrier is used in a system all must have the same polarity. i.e. all positive or all negative barriers.

When designing a system it is important to remember that terminals 2, 6 and RS2 are interconnected within the BA367E-SS see Fig 1.

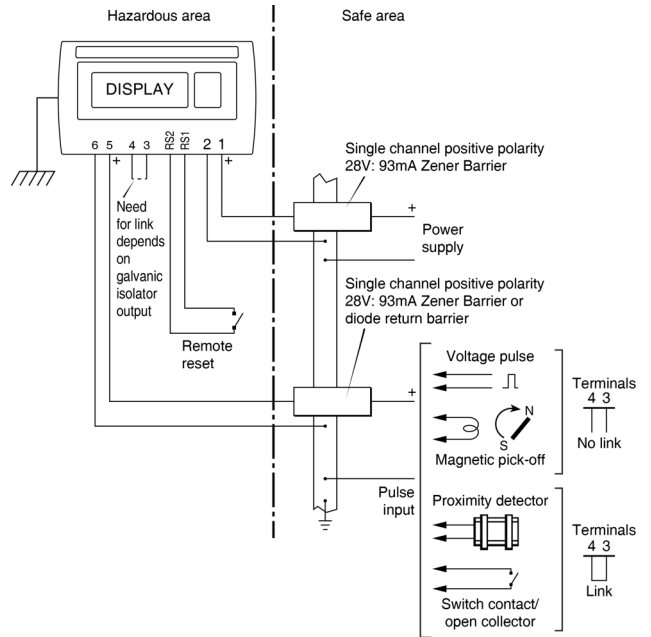

Fig 3 BA367E-SS used with Zener barriers pulse source in safe area.

4.1.1 Power supply

The BA367E-SS Counter requires a minimum of 10V between terminal 1 & 2 and consumes:

	10mA	without optional backlight
plus	22mA	for optional backlight
plus	6mA	when terminals 3 & 4 are linked

Any certified Zener barrier may be used to power a BA367E-SS Counter providing the output safety parameters of the barrier are equal to or less than the input safety parameters of terminals 1 & 2 of the BA367E-SS Counter.

Although this allows a wide variety of barriers to be used, a positive polarity 28V; 93mA; 300Ω Zener barrier, which has an end-to-end resistance of about 340Ω, is an industry standard device which is frequently used. With this barrier the supply voltage in the safe area, with the counter input energised, must be between 15.5V and the maximum working voltage of the Zener barrier which, depending upon manufacturer, will be approximately 26V. The minimum voltage increases to 23V if a display backlight is fitted.

4.1.2 Pulse input

As shown in Fig 2 the BA367E-SS can count pulses from a wide variety of sensors in the hazardous area, or from the safe area as shown in Fig 3.

No Zener barrier is required in series with the input if the intrinsically safe pulse source is located within the same hazardous area as the BA367E-SS Counter. The following table shows the switching thresholds for the various types of sensor. For reliable counting the pulse input must fall below the lower threshold and rise above the upper threshold.

Input sensor	Switching thresholds	
	Lower	Upper
Switch	100Ω	1000Ω
Proximity detector	1.2mA	2.1mA
Open collector	2kΩ	10kΩ
Magnetic pick-off	0mV	40mV peak
Voltage pulse low	1.0V	3.0V
Voltage pulse high	3.0V	10.0V

4.1.3 Switch contact input

Any mechanically activated switch contact located in the same hazardous area as the BA367E-SS Counter may be directly connected to pulse input terminals 5 & 6 providing the switch and associated wiring can withstand a 500V rms insulation test to earth. Most magnetically activated reed relays comply with these requirements. The BA367E-SS contains a configurable debounce circuit to prevent contact bounce being counted.

See section 6.6 for details of the maximum counting frequency.

4.1.4 2-wire proximity detector input

Most certified intrinsically safe 2-wire proximity detectors complying with NAMUR switching thresholds may be connected to the BA367E-SS Counter input, providing the input safety parameters of the proximity detector are equal to or greater than the output safety parameters of the Counter inputs i.e.

$$\begin{aligned} U_i &\geq 10.5V \text{ dc} \\ I_i &\geq 8.2mA \text{ dc} \\ P_i &\geq 25mW \end{aligned}$$

and the minimum operating voltage of the proximity detector is less than 7.5V.

See section 6.6 for details of the maximum counting frequency.

4.1.5 Open collector input

Most open collector sensors located in the same hazardous area as the BA367E-SS Counter may be directly connected to pulse input terminals 5 & 6 providing the sensor and associated wiring can withstand a 500V rms insulation test to earth.

See section 6.6 for details of the maximum counting frequency.

4.1.6 Magnetic pick-off input

$\lceil_{0, L}$ in the input configuration menu is a low level voltage pulse input intended for use with magnetic pick-off sensors producing an ac output. For a $\lceil_{0, L}$ input with no link between terminals 3 and 4, the BA367E-SS pulse input terminals 5 & 6 comply with the requirements of *simple apparatus*. This allows connection to any certified intrinsically safe magnetic pick-off within the hazardous area having output parameters equal to or less than:

$$\begin{aligned} U_o &\leq 28V \text{ dc} \\ I_o &\leq 200mA \text{ dc} \\ P_o &\leq 0.84W \end{aligned}$$

The maximum permitted cable parameters will be defined by the magnetic pick-off's intrinsic safety certificate less the Counter's input parameters C_i & L_i which are small and can often be ignored.

See section 6.6 for details of the maximum counting frequency.

4.1.7 Voltage pulse input

Two voltage pulse input ranges are selectable in the configuration menu, $U_{0, L, 5, L}$ and $U_{0, L, 5, H}$. When configured for either of the voltage pulse ranges, with no link between terminals 3 and 4, the BA367E-SS pulse input terminals 5 & 6 comply with the requirements of *simple apparatus*. This allows connection to any intrinsically safe voltage source within the hazardous area having output parameters equal to or less than:

$$\begin{aligned} U_o &\leq 28V \text{ dc} \\ I_o &\leq 200mA \text{ dc} \\ P_o &\leq 0.84W \end{aligned}$$



The maximum permitted cable parameters will be determined by C_o and L_o of the intrinsic safe voltage source less C_i and L_i of the BA367E-SS Counter.

See section 6.6 for details of the maximum counting frequency.

4.1.8 Remote reset

The BA367E-SS Counter's total display may be remotely reset to zero by connecting terminals RS1 & RS2 together for more than one second. Permanent interconnection inhibits counting. Remote resetting may be accomplished by any mechanically operated switch located in the same hazardous area as the Counter providing it and the associated wiring can withstand a 500V rms insulation test to earth. No Zener barrier is required.

A BA367E-SS may also be remotely reset from the safe area. Any switch may be used but a Zener barrier is required to transfer the contact closure into the hazardous area which may be combined with the supply barrier so that only one package is required. A diode return barrier is not suitable for this application. Fig 2 illustrates how the BA367E-SS may be reset from both the safe and the hazardous area.

Note: The BA367E-SS can be configured to reset the total display when the  and  push buttons are operated simultaneously for more than two seconds - see 6.19.

4.2 Use with Galvanic Isolators

Galvanic isolators are probably the simplest intrinsically safe interface to install as they provide isolation and do not require a high integrity earth connection.

Any certified galvanic isolator with output parameters less than the input parameters of the BA367E-SS having the correct function may be used.

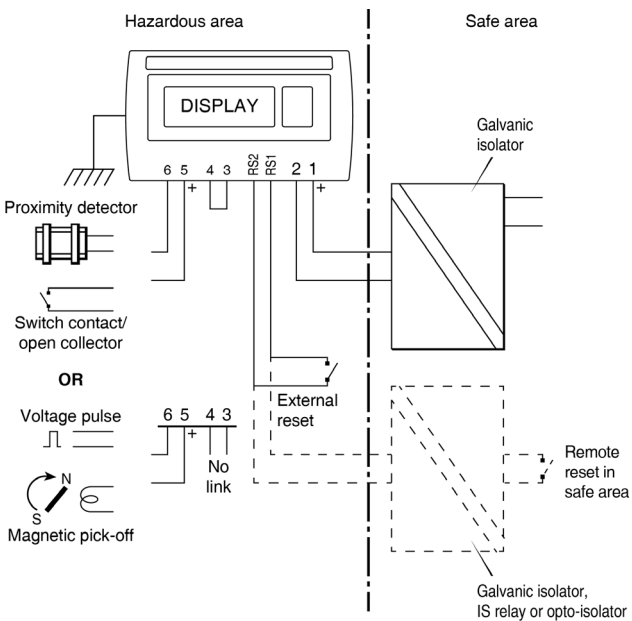

Fig 4 BA367E-SS protected by galvanic isolators.

Fig 4 illustrates the basic circuit that is used for all BA367E-SS Counter installations protected by galvanic isolators. For simplicity, connections for the optional alarms, pulse output and 4/20mA output are shown separately in section 9 of this manual.

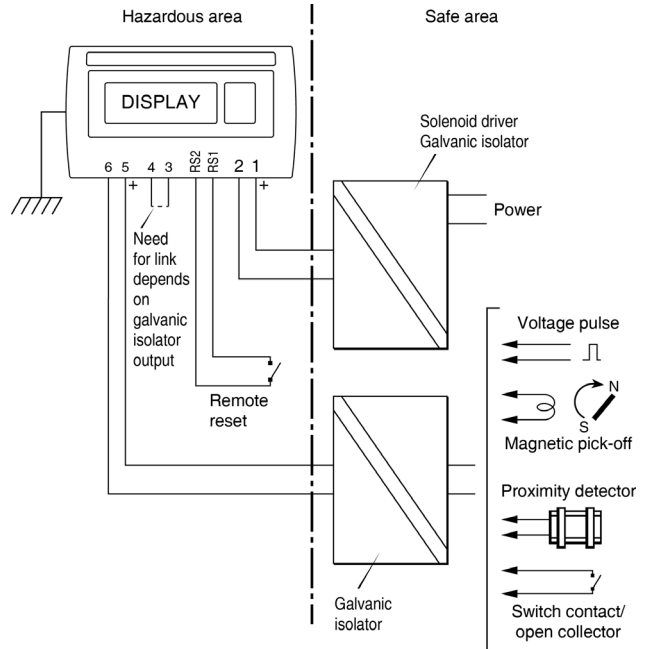

Fig 5 BA367E-SS protected by galvanic isolators. pulse source in safe area.

Alternatively the pulse source may be located in the safe area. Fig 5 shows how an additional galvanic isolator is used to transfer the signal to the BA367E-SS Counter in the hazardous area, although it may be difficult to find isolators for some sensors.

4.2.1 Power supply

The BA367E-SS Counter requires a minimum of 10V between terminal 1 & 2 and consumes:

- 10mA without optional backlight
- plus 22mA for optional backlight
- plus 6mA when terminals 3 & 4 are linked

Any certified galvanic isolator may be used to power a BA367E-SS Counter providing the output safety parameters of the isolator are equal to or less than the input safety parameters of terminals 1 & 2. These requirements are not restrictive and allow a wide range of galvanic isolators, such as solenoid drivers, to be used.

4.2.2 Pulse input

As shown in Fig 4 the BA367E-SS can count pulses from a wide variety of sensors in the hazardous area, or from the safe area as shown in Fig 5.

No galvanic isolator is required in series with the input if the intrinsically safe pulse source is located within the same hazardous area as the BA367E-SS Counter.

The following table shows the switching thresholds for the various types of sensor. For reliable counting the pulse input must fall below the lower threshold and rise above the upper threshold.

Input sensor	Switching thresholds	
	Lower	Upper
Switch	100Ω	1000Ω
Proximity detector	1.2mA	2.1mA
Open collector	2kΩ	10kΩ
Magnetic pick-off	0mV	40mV peak
Voltage pulse low	1.0V	3.0V
Voltage pulse high	3.0V	10.0V

4.2.3 Switch contact input

Any mechanically activated switch contact located in the same hazardous area as the BA367E-SS Counter may be directly connected to pulse input terminals 5 & 6 providing the switch and associated wiring can withstand a 500V rms insulation test to earth. Most magnetically activated reed relays comply with these requirements. The BA367E-SS contains a configurable debounce circuit to prevent contact bounce being counted.

See section 6.6 for details of the maximum counting frequency.

4.2.4 2-wire proximity detector input

Most certified intrinsically safe 2-wire proximity detectors complying with NAMUR switching thresholds may be connected to the BA367E-SS Counter input, providing the input safety parameters of the proximity detector are equal to or greater than the output safety parameters of the Counter inputs i.e.

$$\begin{aligned} U_i &\geq 10.5V \text{ dc} \\ I_i &\geq 8.2mA \text{ dc} \\ P_i &\geq 25mW \end{aligned}$$

and the minimum operating voltage of the proximity detector is less than 7.5V.

See section 6.6 for details of the maximum counting frequency.

4.2.5 Open collector input

Most open collector sensors located in the same hazardous area as the BA367E-SS Counter may be directly connected to the pulse input terminals 5 & 6 providing the sensor and associated wiring can withstand a 500V rms insulation test to earth. This includes most sensor optoisolators.

See section 6.6 for details of the maximum counting frequency.

4.2.6 Magnetic pick-off input

U_{OL} in the input configuration menu is a low level voltage pulse input intended for use with magnetic pick-off sensors producing an ac output. For a U_{OL} input the pulse input terminals 5 & 6 of the BA367E-SS Counter comply with the requirements of *simple apparatus* allowing connection to any certified intrinsically safe magnetic pick-off within the hazardous area having output parameters equal to or less than:

$$\begin{aligned} U_o &\leq 28V \text{ dc} \\ I_o &\leq 200mA \text{ dc} \\ P_o &\leq 0.84W \end{aligned}$$

The maximum permitted cable parameters will be defined by the magnetic pick-off's intrinsic safety certificate less the Counter's input parameters C_i & L_i which are small and can usually be ignored.

See section 6.6 for details of the maximum counting frequency.

4.2.7 Voltage pulse input

Two voltage pulse input ranges are selectable in the configuration menu, $U_{OL}L5 L$ and $U_{OL}L5 H$. When configured for either of the voltage pulse ranges, the pulse input terminals 5 & 6 of the BA367E-SS Counter comply with the requirements of *simple apparatus* allowing connection to any intrinsically safe voltage source within the hazardous area having output parameters equal to or less than:



$$\begin{aligned} U_o &\leq 28V \text{ dc} \\ I_o &\leq 200mA \text{ dc} \\ P_o &\leq 0.84W \end{aligned}$$

The maximum permitted cable parameters will be defined by the voltage source intrinsic safety certificate less the BA367E-SS Counter input parameters which are small and can usually be ignored. See section 6.6 for details of the maximum counting frequency.

4.2.8 Remote reset

The BA367E-SS Counter may be remotely reset by connecting terminals RS1 & RS2 together for more than one second. Permanent interconnection inhibits counting. Remote resetting may be accomplished by any mechanically operated switch located in the same hazardous area as the Counter providing it and the associated wiring can withstand a 500V rms insulation test to earth. No galvanic isolator is required.

A BA367E-SS Counter may also be remotely reset from the safe area. Any switch may be used but a galvanic isolator or IS relay is required to transfer the contact closure into the hazardous area. Almost any device with a contact that may be connected to equipment in the hazardous area may be used for this application. Fig 4 illustrates how a BA367E-SS Counter may be reset from both the safe and the hazardous area.

Note: The BA367E-SS can be configured to reset the total display when the  and  push buttons are operated simultaneously for more than two seconds - see 6.19.

4.3 Use in an Ex e or Ex p panel enclosure located in Zone 1 or Zone 2.

The BA367E-SS ATEX EC-Type Examination Certificate allows the Counter to be installed in an Ex e IIC Gb increased safety panel enclosure located in Zone 1 or 2, or in an Ex p IIC Gb pressurised panel enclosure located in a Zone 1 or 2 hazardous area. The BA367E-SS may also be installed in an Ex n enclosure located in Zone 2. When installed in a certified panel enclosure the BA367E-SS Counter remains intrinsically safe and must be protected by a Zener barrier or galvanic isolator as described in sections 4.1 and 4.2. However when correctly installed, the Counter does not invalidate the certification of the Ex e, Ex n or Ex p panel enclosure allowing installation with higher power control equipment.

4.3.1 Installation in an Ex e panel enclosure

Installation of a BA367E-SS Counter in an Ex e IIC Gb increased safety panel enclosure does not invalidate the Ex e panel's ingress and impact protection as the front of the BA367E-SS complies with Ex e impact and ingress requirements. Although mounted in an Ex e panel enclosure, the BA367E-SS remains Group II Category 1G Ex ia IIC T5 Ga intrinsically safe apparatus and must therefore be powered via a Zener barrier or galvanic isolator as described in section 4.1 and 4.2 of this manual.

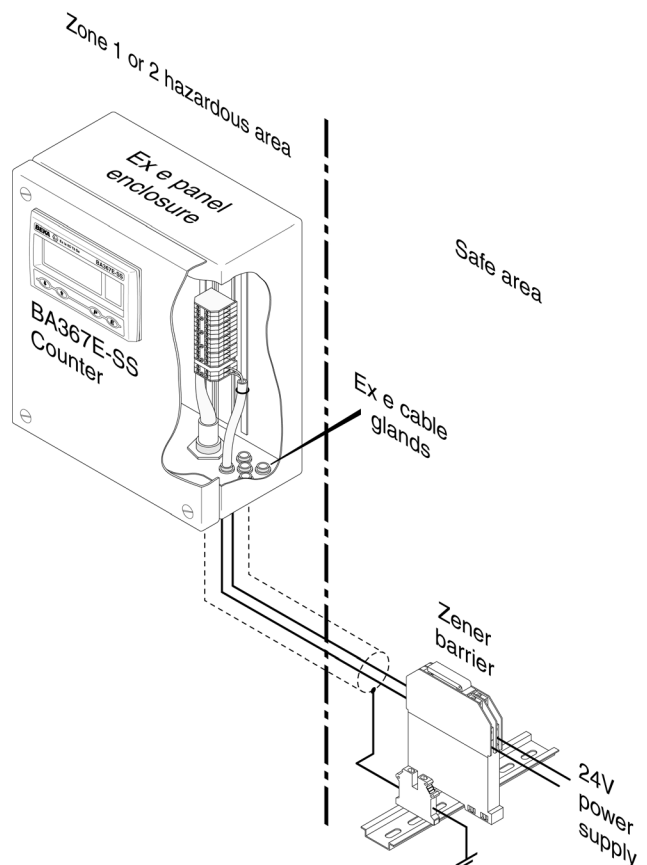

Fig 6 Typical installation in Ex e panel enclosure

Some Zener barriers and galvanic isolators are certified for mounting within a protective enclosure located in Zone 2 which may permit them to be mounted in the same Ex e enclosure as the BA367E-SS Counter. Zener barriers and galvanic isolators are not permitted in Ex e enclosures located in Zone 1.

The Counter terminals, the wiring to the Counter and the intrinsically safe interface, if mounted within the enclosure, should be segregated from all other non-intrinsically safe wiring and equipment within the panel enclosure as required by EN 60079-11 *Equipment protected by intrinsic safety* and EN 60079-14 *Electrical installations design, selection and erection*.

The Ex e panel enclosure should be fitted with a warning label saying 'Do not open when non-intrinsically safe circuits are energised', alternatively all bare live non-intrinsically safe parts within the panel enclosure should have an IP30 cover carrying a warning label 'Do not open when energised'.

The power dissipation within an BA367E-SS fitted with operational alarms and a backlight is normally about 350mW. In the very unlikely event that all three circuits fail to the worst case condition at the same time, the total power dissipation rises to 2.5W which could raise the internal temperature of a small thermally well insulated panel enclosure.

4.3.2 Installation in Ex p panel enclosure within

Installation of a BA367E-SS Counter in an Ex p IIC Gb or Ex p IIC Gc pressurised panel enclosure does not invalidate the Ex p panel's impact and ingress protection as the front of the Counter complies with Ex p impact and ingress requirements. Although mounted in an Ex p panel enclosure, the BA367E-SS remains Group II Category 1G Ex ia IIC T5 Ga intrinsically safe apparatus and must therefore be powered via a Zener barrier or galvanic isolator as described in section 4.1 and 4.2 of this manual to ensure that the instrument's front panel push button switches are nonincendive.

When installed in an Ex p panel enclosure the four vents at the rear of the Counter which are shown in Fig 8 should not be obstructed.

Zener barriers and galvanic isolators may be installed in the same Ex p enclosure as the BA367E-SS. All may be mounted in an Ex px enclosure installed in Zones 1 or 2, or in an Ex pz enclosure installed in Zone 2, both of which have a non-hazardous interior. Some Zener barriers and galvanic isolators may have certification permitting installation within an Ex py enclosure which has a Zone 2 interior.

The Counter's terminals, the wiring to the Counter and the intrinsically safe interface, if mounted within

the enclosure, should be segregated from all other non-intrinsically safe wiring and equipment within the panel enclosure as required by EN 60079-11 *Equipment protected by intrinsic safety* and EN 60079-14 *Electrical installations design, selection and erection*.

If live maintenance is anticipated, it is recommended that the Ex p panel enclosure should be fitted with a warning label saying 'Do not open when non-intrinsically safe circuits are energised', alternatively all bare live non-intrinsically safe parts within the panel enclosure should have an IP30 cover carrying a warning label 'Do not open when energised'.

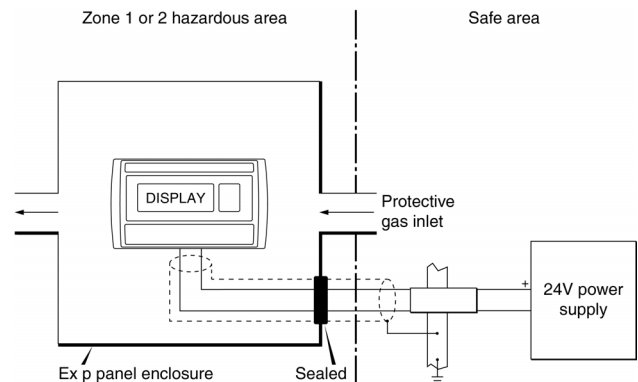

Fig 7 Typical installation in Ex p panel enclosure

5. INSTALLATION

5.1 Location

The BA367E-SS has a stainless steel case with a 10mm thick toughened glass window. The case provides 7J and the window 4J front of panel impact protection. The captive silicone gasket, which seals the joint between the instrument and the panel enclosure, ensures IP66 front of panel ingress protection. The rear of the Counter has IP20 protection.

Although the front of the BA367E-SS has IP66 protection, it should be shielded from continuous direct sunlight and severe weather conditions.

The BA367E-SS may be located in Zone 0, 1 or 2 providing that the operating temperature is between -40°C and $+60^{\circ}\text{C}$ and the installation complies with the certification requirements.

Installation in Ex e and Ex p panel enclosures are described in sections 4.3.1 and 4.3.2.

Fig 8 show the overall dimensions of the BA367E-SS together with the recommended panel enclosure cut-out dimensions and terminal locations.

5.2 Installation Procedure

- Cut the aperture specified in Fig 8 in the panel enclosure. Ensure that the edges of aperture are de-burred.
- Inspect the Counter's captive gasket and ensure that it is not damaged before inserting the Counter into the panel enclosure aperture.
- If the enclosure panel is less than 1.0mm thick, or is non-metallic, an optional BEKA stainless steel support plate should be slid over the rear of the Counter before the panel clamps are fitted to evenly distribute the clamping force and prevent the enclosure panel being distorted or creeping.
- Slide a panel clamp into the two grooves at each corner of the indicator housing with the M3 stud protruding through the hole at the rear of the clamp. Fit the stainless steel spring washer over the stud and secure with the stainless steel wing nut.
- Evenly tighten the four clamps to secure the instrument. The recommended minimum tightening torque for each wing nut is 22cNm (1.95 lbf in).
- Connect the panel enclosure wiring to the rear terminal blocks. To simplify installation, the terminals are removable so that wiring can be completed before the instrument is installed. Cables should be mechanically secured to ensure terminals are not damaged by vibration.

- Finally, fit a silicone rubber push-on cap to the end of each M3 threaded rod.

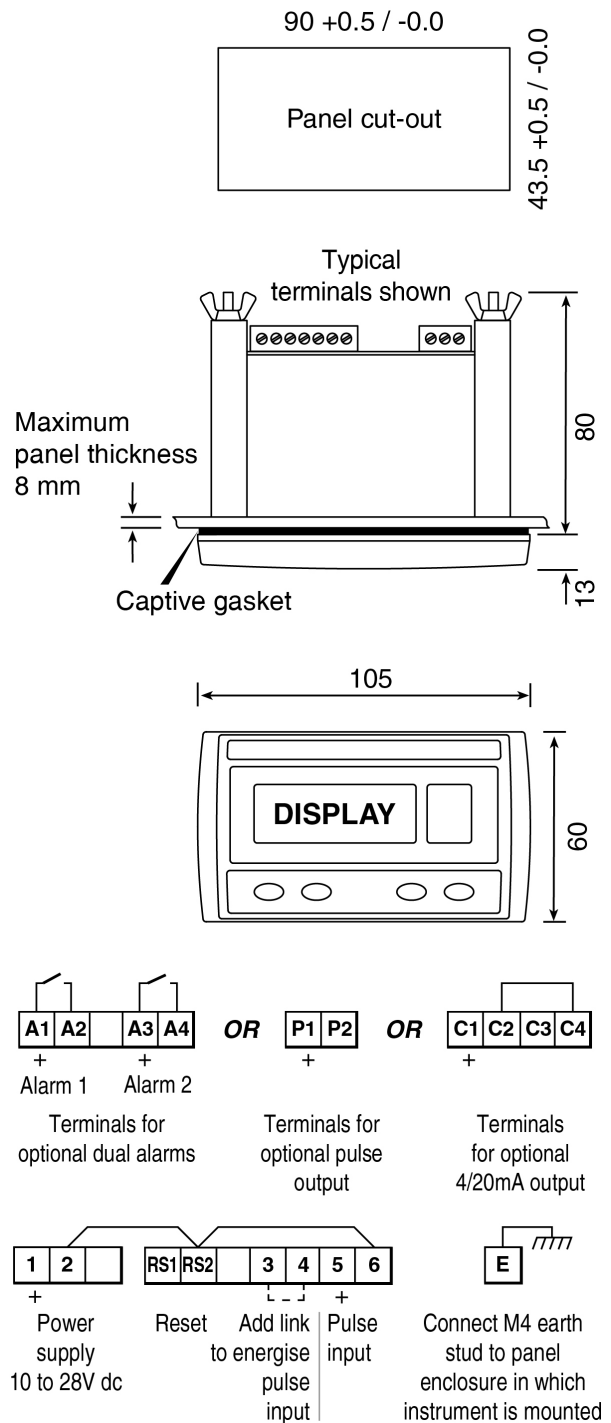

Support panel wiring to prevent vibration damage

Note: Optional backlight is internally powered

Fig 8 Dimensions and terminals

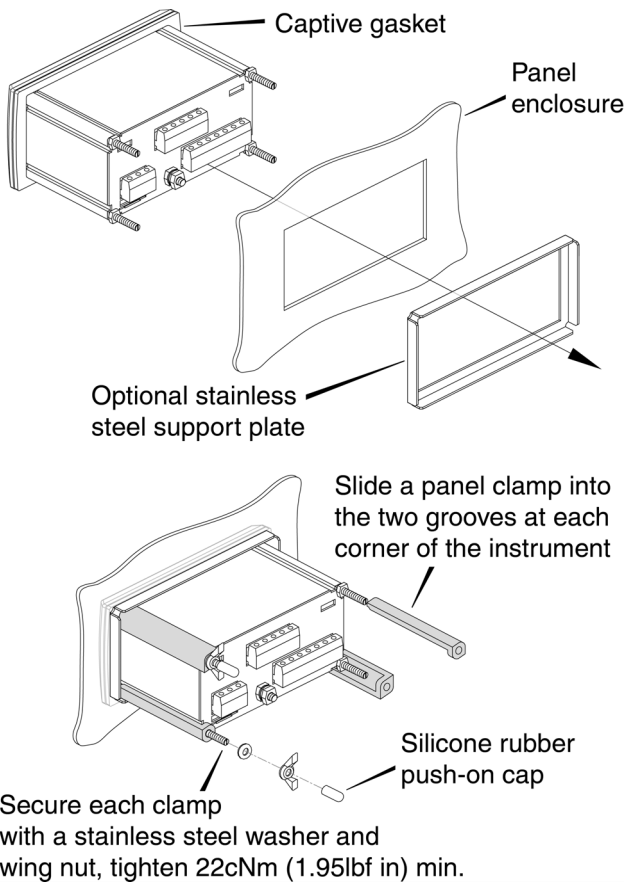

Fig 9 Installation procedure

5.3 EMC

The BA367E-SS complies with the requirements of the European EMC Directive 2014/30/EU. For specified immunity all wiring should be in screened twisted pairs, with the screens earthed at one point within the safe area.

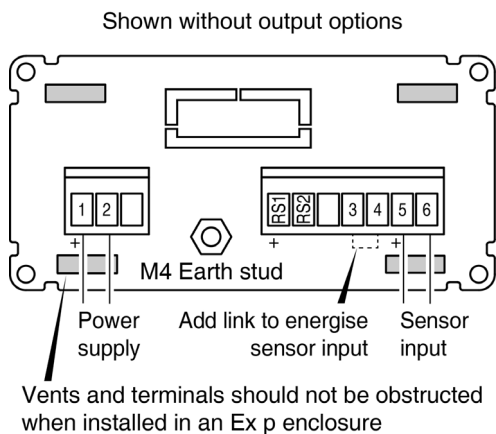

Fig 10 Terminals for field wiring

5.4 Counter earthing

The BA367E-SS has an M4 earth stud on the rear panel which should be electrically connected to the panel enclosure in which the instrument is mounted, or to the plant equipotential conductor.

5.5 Scale card

The Counter's units of measurement are shown on a printed scale card in a window at the right hand side of the display. The scale card is mounted on a flexible strip that is inserted into a slot at the rear of the instrument as shown in Fig 11. Thus the scale card can easily be changed without removing the Counter from the panel or opening the instrument enclosure.

New Counters are supplied with a printed scale card showing the requested units of measurement, if this information is not supplied when the instrument is ordered a blank card will be fitted.

A pack of self-adhesive scale cards printed with common units of flow measurement is available as an accessory from BEKA associates. Custom printed scale cards can also be supplied.

To change a scale card, unclip the tapered end of the flexible strip at the rear of the instrument by gently pushing it upwards and pulling it out of the enclosure. Peel the existing scale card from the flexible strip and replace it with a new printed card, which should be aligned as shown below. Do not fit a new scale card on top of an existing card.

Install the new scale card by gently pushing the flexible strip into the slot at the rear of the Counter, when it reaches the internal end-stop secure it by pushing the end of the flexible strip downwards so that the tapered section is held by the rear panel.

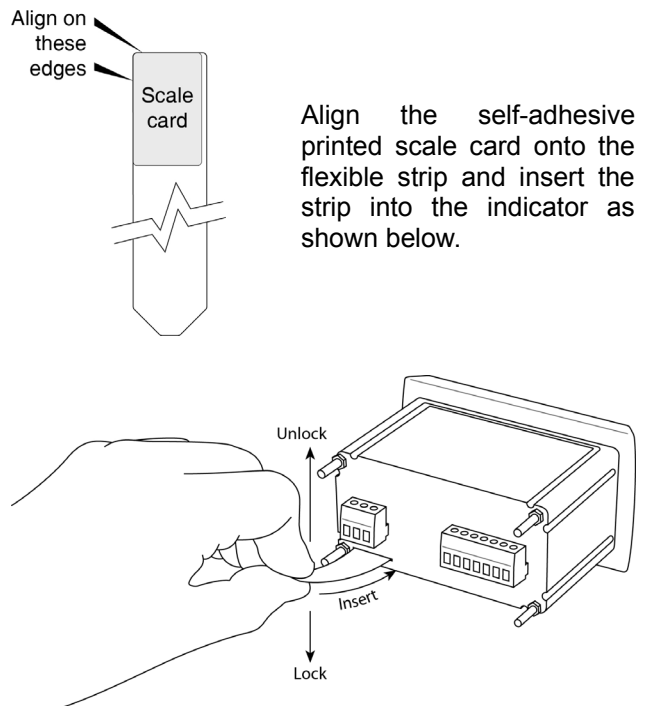

Fig 11 Inserting flexible strip carrying scale card into slot at the rear of the Tachometer.

6.0 CONFIGURATION & CALIBRATION

The BA367E-SS Counter is configured and calibrated via four front panel push buttons. All the configuration functions are contained in an easy to use intuitive menu that is shown diagrammatically in Fig 13.

Each menu function is summarised in section 6.3 of this manual and each summary includes a reference to more detailed information.

When factory fitted optional dual alarms, pulse output or a 4/20mA output are included, additional functions appear in the configuration menu which are described separately in section 9.

All new BA367E-SS Counters are supplied calibrated as requested at the time of ordering. If calibration is not requested, Counters will have default configuration as shown in the following table, but can easily be re-configured on-site.

Function	Display	Default
Input		
Input type	INP.TYPE	OP.COUNT
Debounce	DEBOUNCE	DEFRAUL
Counting edge	CNT EDGE	EDGE 1
Update	UPDATE	05
Upper display	DISP-1	total
Lower display	DISP-2	on
Decimal point	DP	Rate 00000.0 Total 00000000
Total scale factor	SCALE.t	00 1.00
Rate scale factor	SCALE.r	00 1.00
Timebase	T-BASE	t-b-0 1
Filter	FILT	24
Counter direction	UP OR DN	UP
Clear value	CLR VAL	00000000
Local clear		
Local total reset	CLR tot	OFF
Local grand total reset	CLR Gtot	OFF
Security code	CODE	0000

SCALE.r is a dividing factor that converts the input pulses into a rate display with the required engineering units. e.g. if the input is two pulses per pump stroke and it is required to display the pump stroke rate, SCALE.r should be set to 2.0.

The timebase T-BASE is a multiplying factor that determines if the instrument displays pulse rate per second, per minute or per hour.

The BA367E-SS uses 'real' decimal points. Moving the position of a decimal point in a scale factor will affect the instrument calibration.

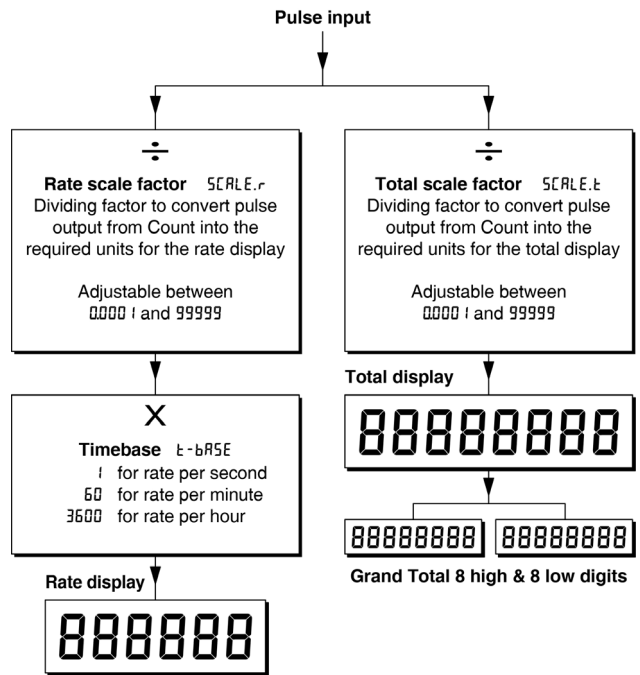

Fig 12 Calibration structure





Note: While the instrument is being configured counting continues so that any input pulses occurring during this time are recorded.







6.1 Configuration structure

Fig 12 shows the configuration structure of the BA367E-SS Counter. The pulse input is passed to the SCALE.r and SCALE.t functions allowing the independent rate and total displays to have different engineering units.



SCALE.t is a dividing factor that converts the input pulses into the required total display in engineering units. e.g. if the input is two pulses per pump stroke and it is required to display the total number of pump strokes in thousands of strokes, SCALE.t should be set to 2000.

6.2 Accessing configuration functions

Throughout this manual the instrument front panel push buttons are shown as , ,  and  and legends displayed by the instrument are shown in a seven segment font as displayed by the Counter e.g. *F, LkEr* and *ScRLr*.

Access to the configuration menu is obtained by operating the  and  push buttons simultaneously. If the instrument is not protected by a security code the first parameter *iPUL* will be displayed. If a security code other than the default code *0000* has already been entered, the instrument will display *codE*. Press  to clear this prompt and enter the security code for the instrument using the  or  push button to adjust the flashing digit, and the  push button to transfer control to the next digit. If the correct code has been entered pressing  will cause the first parameter *iPUL* to be displayed. If an incorrect code is entered, or a push button is not operated within ten seconds, the instrument will automatically return to the display mode.

All configuration functions and prompts are shown on the upper eight digit display.

Once within the configuration menu the required function can be selected by scrolling through the menu using the  and  push buttons. The configuration menu is shown diagrammatically in Fig 13.

When returning to the display mode following reconfiguration, the BA367E-SS Counter will display *dRr* followed by *SRUE* while the new information is stored in permanent memory.

If after accessing the configuration menu the interval between operating any front panel push button exceeds one minute, the BA367E-SS will automatically return to the display mode and any configuration changes will not be stored in permanent memory. When making changes to multiple configuration functions, it is therefore sensible to occasionally return to the display mode to save the changes that have already been made.

6.3 Summary of configuration functions

This section summarises all the configuration functions. When read in conjunction with Fig 13 it provides a quick aid for configuring the Counter. If more detail is required, each section contains a reference to a full description of the function.

Display	Summary of function
<i>iPUL</i>	Contains sub-menu with two functions: <i>iP. TYPE</i> Select Input type <i>dEbounCE</i> Set debounce See section 6.4
<i>iP. TYPE</i>	Configures input to accept one of six types of input: <i>oP. CoL</i> Open collector * <i>UoLk5 L</i> Voltage pulse <1 >3V <i>UoLk5 H</i> Voltage pulse <3 >10V <i>Co, L</i> Magnetic pick-off <i>P.r.dEt</i> Proximity detector * <i>CoNtREt</i> Switch contact *
	* Link terminals 3 & 4 See section 6.5
<i>dEbounCE</i>	Defines level of input debounce applied to the pulse input to prevent false counting: <i>dEFAULt</i> <i>HEruY</i> <i>L, GHt</i> See section 6.6
<i>CoNt EdGE</i>	Input pulse counting edge Defines whether the Counter is incremented/decremented on the leading or trailing edge of an input pulse. See section 6.7
<i>uPdRrE</i>	Display update interval Defines the interval between display updates between 0.5 and 5 seconds. See section 6.8



Display	Summary of function	Display	Summary of function
$d, 5P-1$	<p>Upper display Defines whether $rATE$ or $totRL$ are shown on the upper display. The other variable will be shown on the lower display, providing the lower display is on in function $d, 5P-2$. See section 6.9</p>	$t-bASE$	<p>Timebase Selectable multiplier allowing rate to be displayed in units per second, per minute or per hour. Select: $tB-01$ for rate / second $tB-60$ for rate / minute $tB-3600$ for rate / hour See section 6.14</p>
$d, 5P-2$	<p>Lower display Turns the lower display, which normally shows rate, on or off. See section 6.10</p>	$F, LLEr$	<p>Display filter Is an adjustable digital filter to reduce the noise on the rate display. The filter has two parameters each represented by a digit adjustable between 0 and 9. The first digit defines the amount of filtering applied to the display, the second digit the deviation from the displayed rate at which the filter will be overridden and the rate display will move rapidly to the new value. See section 6.15</p>
dP	<p>Position of decimal points Defines the position of the decimal point in both the total and rate displays. See section 6.11</p>	uP or dn	<p>Direction of count Determines whether input pulses increment or decrement the total display. See section 6.16</p>
$SCALE.t$	<p>Total Scale Factor $SCALE.t$ is a dividing factor that converts the number of input pulses into the required total display in engineering units. $SCALE.t$ may be adjusted between 0.0001 & 99999. e.g. if one input pulse represents 1 centimetre of dispensed cable and the total display is required in metres, $SCALE.t$ should be set to 100.0 which is the number of centimetres in a metre. The total display is independent of the rate display. See section 6.12</p>	$CLR UAL$	<p>Reset value Defines a preset number to which the total display will be set when the BA367E-SS Counter is locally or remotely reset. Enables the instrument to count down from a preset number. See section 6.17</p>
$SCALE.r$	<p>Rate scale factor $SCALE.r$ is a dividing factor that converts the input pulse rate into the required rate display in engineering units. $SCALE.r$ may be adjusted between 0.0001 and 99999. e.g. if one pulse represents 2 pump strokes and the rate display is required in pump strokes, $SCALE.r$ should be set to 2.0. The rate display is independent of the total display. See section 6.13</p>		

Display	Summary of function
---------	---------------------

LoC CLR	<p>Local clear Contains sub-menu with two functions enabling the total and the grand total to be reset via the front panel push buttons while the Counter is in the display mode.</p>
---------	--



See section 6.18

CLR tot

When tot is selected total display is reset when  and  buttons are operated simultaneously for more than three seconds in the display mode.

See section 6.19

CLR Gtot

When tot is selected the grand total may be reset when  and  buttons are operated simultaneously for more than 10 seconds in the display mode - see section 2.2 for details.

Note: Once reset, the grand total can not be restored.

See section 6.20

CLR Gtot	<p>Resets grand total to zero from within configuration menu.</p>
----------	--

This function resets the grand total to zero from within the configuration menu when CLR 5E5 is selected.

Note: Once reset, the grand total can not be recovered.

See section 6.21

Display	Summary of function
---------	---------------------

Code	<p>Access code Defines a four digit alphanumeric code that must be entered to gain access to the configuration menu. Default code 0000 disables the security function and allows unrestricted access to all configuration functions.</p>
------	---

See section 6.22

r5Et dEF	<p>Reset to factory defaults</p>
----------	---

Returns the BA367E-SS Counter to the factory defaults shown in section 6.0 To prevent accidental use the request must be confirmed by entering 5urE before the reset will be executed.

See section 6.23

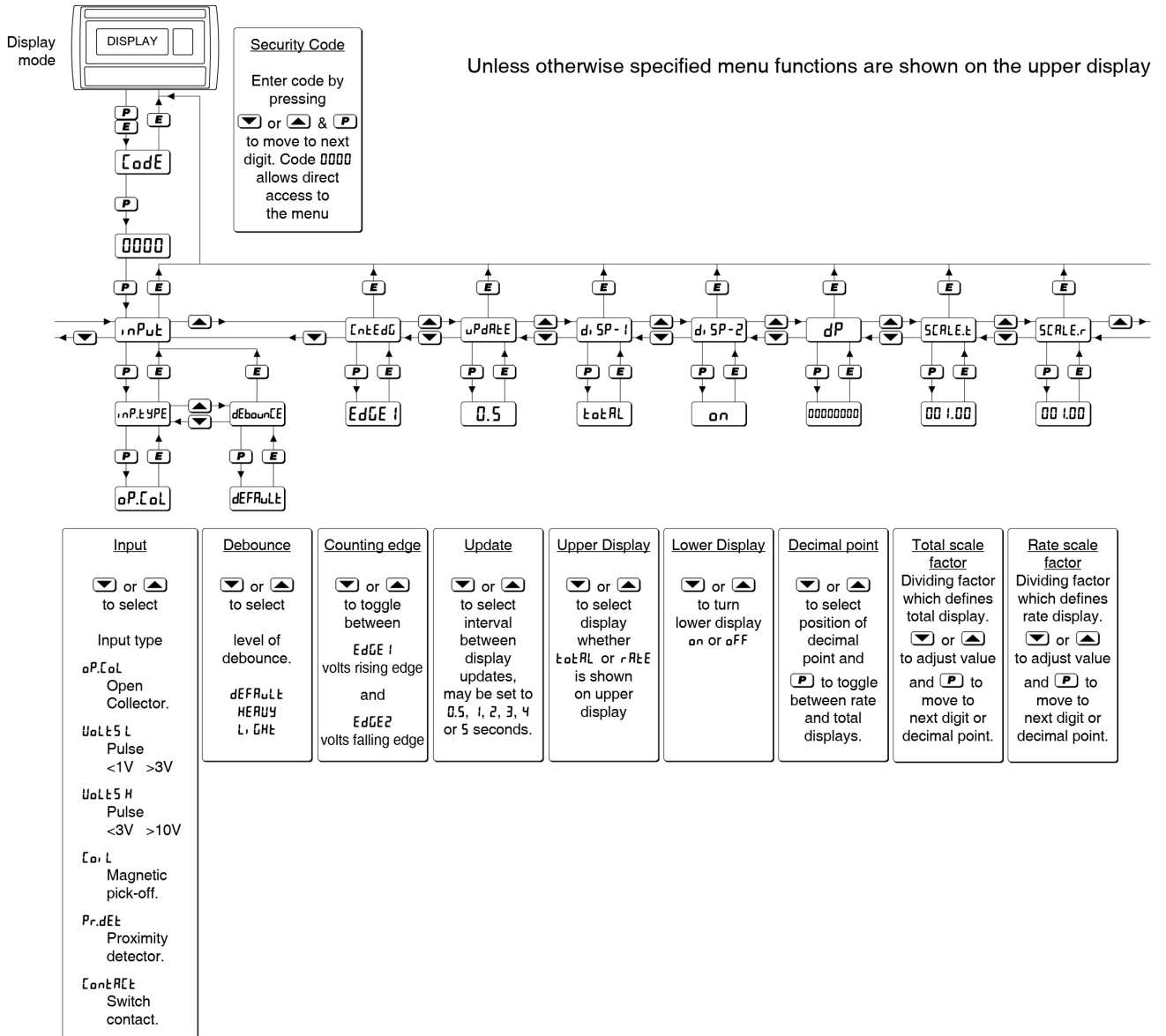
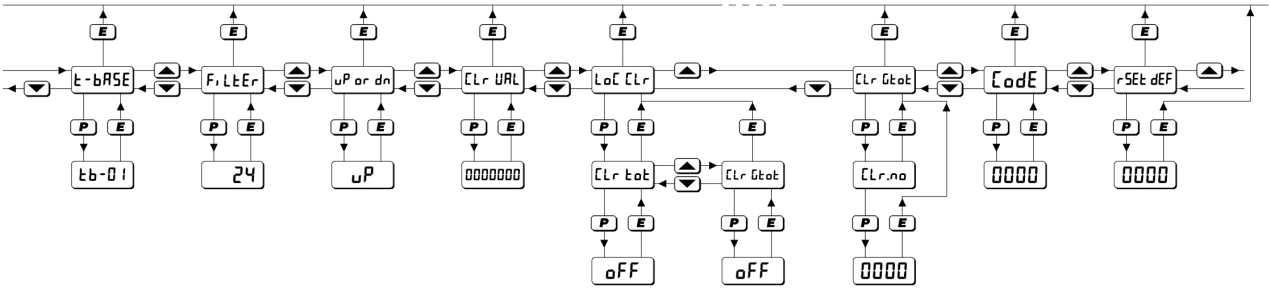

Fig 13 Configuration menu

Optional pulse output, alarms
or 4/20mA output appear here



<p>Timebase</p> <p>▼ or ▲ to select rate display timebase.</p> <p>t-b-01 for pulses/sec</p> <p>t-b-60 for pulses/min</p> <p>t-b-3600 for pulses/hour</p>	<p>Filter input</p> <p>▼ or ▲ to adjust value of each digit and P to transfer control to the next digit.</p> <p>First digit: filter magnitude</p> <p>Second digit: step response</p> <p>Note: While making adjustments the filtered rate display is shown on lower display so stability can be assessed</p>	<p>Direction of count</p> <p>▼ or ▲ to toggle between uP and dn</p>	<p>Reset value</p> <p>▼ or ▲ to adjust value of each digit and P to transfer control to the next digit.</p>	<p>Local total reset</p> <p>▼ or ▲ to turn the local total reset function on or off. When on is selected, Total may be reset when ▼ and ▲ are pressed simultaneously for more than 3 seconds in the display mode.</p>	<p>Local grand total reset</p> <p>▼ or ▲ to turn the local grand total reset function on or off. When on, grand total display may be reset when E and ▲ are pressed simultaneously for more than 10 seconds in the display mode.</p>	<p>Grand total reset</p> <p>Press ▼ or ▲ to select CLr.YE5 to reset grand total to zero</p> <p>Confirm instruction by entering 5urE. Press ▼ or ▲ to adjust each digit and P to move to next digit</p>	<p>Define Security Code</p> <p>Enter by pressing ▼ or ▲ and P to move to next digit.</p> <p>Default code 0000 allows direct access to configuration menu</p>	<p>Reset configuration to factory defaults</p> <p>Confirm instruction by entering 5urE. Press ▼ or ▲ to adjust each digit and P to move to next digit</p>
---	--	--	---	--	--	--	--	---

6.4 Input: , nPUL

The Input function contains two sub-functions , nP.ŁYPE and dEBouNŁŁE that define the type of input and the amount of input noise rejection.

6.5 Input type: , nP.ŁYPE

, nP.ŁYPE is a sub-menu in the , nPUL function which defines the type of input sensor or input pulse that the instrument will count. To check or change the type of input, select , nPUL in the configuration menu and press [P] which will reveal the , nP.ŁYPE prompt, pressing [P] again will show the existing Input setting. If set as required press [E] twice to return to the configuration menu, or repeatedly press the [V] or [A] button until the required type of input is displayed and then press [E] twice to return to the configuration menu.

One of following six types of input may be selected:

		Switching thresholds	
		Low	High
oP.ŁoL	Open collector ²	2	10kΩ
UoŁŁŁL	Voltage pulse low ¹	1	3V
UoŁŁŁH	Voltage pulse high ¹	3	10V
Ło, L	Magnetic pick-off	0	40mV
Pr.dŁŁ	Proximity detector ²	1.2	2.1mA
ŁoNŁRŁŁ	Switch contact ²	100	1000Ω

Notes:

1. Maximum voltage input +28V.
2. For sensors connected to the input that require energising i.e. proximity detectors, switch contacts or open collector sensors, terminals 3 & 4 of the BA367E-SS should be linked together.
3. To count correctly, the input pulse must fall below the lower switching threshold and rise above the higher switching threshold.
4. See section 6.6 for maximum counting frequency.

6.6 Input debounce: dEBouNŁŁE

dEBouNŁŁE is an adjustable sub-menu in the , nPUL function which prevents the input miscounting when the input pulse has noisy edges, such as those resulting from a mechanical contact closing and bouncing.

Three levels of protection may be selected. The amount of debounce applied depends upon the type of Counter input that has been selected in the , nP.ŁYPE function.

Select , nPUL in the configuration menu and press [P] which will reveal the , nP.ŁYPE prompt, press the [V] or [A] button to select dEBouNŁŁE followed by [P] to reveal the existing setting. Pressing the [V] or [A] button will scroll through the three levels. When the required level has been selected, pressing [E] twice will enter the selection and return the display to the configuration menu.

The following table shows the minimum time that the input pulse must be continuously above the upper input switching threshold and continuously below the lower switching threshold to ensure that the Counter processes the input pulse. Input switching thresholds are shown in section 4.1.2.

debounce level	Min input pulse width	
	Type of Input	
	Contact	All others
Default	1600µs	40µs
Heavy	3200µs	350µs
Light	400µs	5µs

The maximum counting frequency of the BA367E-SS depends upon the debounce level selected, the shape of the input pulse and its amplitude. The following table assumes a square wave input and is included for guidance. The maximum counting frequency will be lower if the input pulses have sloping edges and the pulse amplitude only slightly exceeds the input switching thresholds.

ONLY FOR GUIDANCE		
debounce level	Max counting frequency	
	Type of input	
	Contact	All others
Default	250Hz	12kHz
Heavy	120Hz	2kHz
Light	1000Hz	100kHz

6.7 Input pulse counting edge: Cnt EdGE

This function defines whether the BA367E-SS Counter is incremented/decremented on the leading or trailing edge of an input pulse.

To check or change the input pulse edge on which the count occurs select Cnt EdGE from the configuration menu and press P which will reveal EdGE 1 or EdGE 2 . If required press the V or A button to change the setting, followed by the E button to return to the configuration menu.

EdGE 1

Type of input	Counting edge
Voltage	Low to high
Switch contact	Closed to open
Open collector	Closed to open
Proximity detector	High to low current

EdGE 2

Type of input	Counting edge
Voltage	High to low
Switch contact	Open to closed
Open collector	Open to closed
Proximity detector	Low to high current

6.8 Display update interval: uPdRtE

If either the rate or the total display is likely to change rapidly, a longer interval between display updates may simplify reading. This function allows one of six different display intervals between 0.5 and 5 seconds to be selected. The selected display update interval does not affect the update time of any other instrument function.

To adjust the update interval select uPdRtE from the configuration menu and press P to reveal the current update interval. Pressing the V or A button will scroll through the six times. When the required interval has been selected press E to enter the selection and return to the configuration menu.

6.9 Upper display: d, 5P- 1

Usually the total count is shown on the larger upper eight digit display, but this function reverses the display locations allowing rate to be shown on the larger upper display and total on the smaller lower display.

To check the setting for the display, select d, 5P- 1 from the configuration menu and press P which will reveal if the display is showing rRtE or tOtRL . The setting can be changed by pressing the V or A button followed by the E button to enter the selection and return to the configuration menu.

6.10 Lower display: d, 5P- 2

This function turns the lower display on or off . When turned off , the BA368E will only have one eight digit display which may be configured in the d, 5P- 1 function to show the total count or rate.

To check the setting for the lower display, select d, 5P- 2 from the configuration menu and press P that will reveal if the lower display is on or off . The setting may be changed by pressing the V or A button followed by the E button to enter the selection and return to the configuration menu.

6.11 Position of the decimal points: dP

The upper and lower displays have eight and six digits respectively. This function enables the position of the decimal point in both displays to be independently positioned as shown below.

Upper display		
Total	0000.0000	1 of 5 positions or absent
Rate	000.0000	1 of 4 positions or absent
Lower display		
Total	0.000000	1 of 5 positions or absent
Rate	00.00000	1 of 4 positions or absent

To adjust the position of the decimal points select dP from the configuration menu and press P . The upper display defined as the rate or total display by function d, 5P- 1 (section 6.9) will be activated and identified by the display annunciator as Rate or Total. The decimal point, which may be positioned as shown in the table above, is moved by operating the V or A push button. The V button moves the position of the decimal point to the left and the A button moves the decimal point position to the right.

When the decimal point in the upper display has been positioned pressing the P button will transfer control to the lower display variable, but it will be shown and annunciated on the larger upper display. The position of the decimal point may be positioned in the same way by operating the V and A push buttons. When both decimal points are positioned as required, enter the settings and return to the configuration menu by operating the E button.

Note:

Adjustment of a decimal point position will disable the following outputs which must be re-enabled after the adjustment is complete:

- Pulse output
- Optional Alarm outputs.
- Optional 4/20mA output.

6.12 Total scale factor: $SCALE.t$

$SCALE.t$ is a dividing factor adjustable between 0.0001 and 99999 that enables the total to be displayed in engineering units. e.g. if one input pulse represents 1 centimetre of dispensed cable and the total display is required in metres, $SCALE.t$ should be set to 100.0 which is the number of centimetres in a metre. If a display of the total number of input pulses is required, $SCALE.t$ should be set to 1.0. The total display is independent of the rate display.

To check or change the total scale factor select $SCALE.t$ from the configuration menu and press P which will reveal the existing value with one digit flashing. The value of the flashing digit may be changed by pressing the \blacktriangledown or \blacktriangle button. When this digit has been adjusted as required, pressing P will transfer control to the next digit. When all the digits have been adjusted pressing P will transfer control to the decimal point that may be positioned between any of the digits, or may be omitted by moving it to the right of the least significant digit. When the total scale factor has been entered, press P to return to the $SCALE.t$ prompt in the configuration menu.

Note:

Adjustment of $SCALE.t$ will disable the following outputs which must be re-enabled after the adjustment is complete:

Optional Pulse output

Optional Alarm outputs.

Optional 4/20mA output.

6.13 Rate scale factor: $SCALE.r$

$SCALE.r$ is a dividing factor adjustable between 0.0001 and 99999 that enables the rate display to be in engineering units. e.g. if one input pulse represents 2 pump strokes and the rate display is required in pump strokes, $SCALE.r$ should be set to 2.0. If just the rate of input pulses is required, $SCALE.r$ should be set to 1.0. The rate display is independent of the total display.

The units of the rate display are counts per unit of time. The unit of time is the timebase of the instrument which is determined by $t-bRSE$ described in section 6.14.

To check or change the rate scale factor select $SCALE.r$ from the configuration menu and press P which will reveal the existing value with one digit flashing. The value of the flashing digit may be adjusted by pressing the \blacktriangledown or \blacktriangle button.

When this digit has been adjusted as required, pressing P will transfer control to the next digit. When all the digits have been adjusted pressing P will transfer control to the decimal point that may be positioned between any of the digits, or may be omitted by moving it to the right of the least significant digit. When the required rate scale factor has been entered, press E to return to the $SCALE.r$ prompt in the configuration menu.

Note:

Adjustment of $SCALE.r$ will disable the following outputs which must be re-enabled after the adjustment is complete:

Optional Pulse output

Optional Alarm outputs.

Optional 4/20mA output.

6.14 Timebase: $t-bRSE$

The timebase multiplies the rate display by 1, 60 or 3,600 depending upon whether the BA367E-SS Counter is required to display rate per second, per minute or per hour. See Fig 12.

To check or change the timebase, select $t-bRSE$ from the configuration menu and press P which will reveal the current setting. Pressing the \blacktriangledown or \blacktriangle button will scroll through the three options:

$t-b-1$	for pulses / second
$t-b-60$	for pulses / minute
$t-b-3600$	for pulses / hour

When the required multiplier is displayed press E to return to the $t-bRSE$ prompt in the configuration menu.

6.15 Display filter: $F, LLEr$

The digital display filter has two independent adjustable parameters enabling the rate display response to be tailored for optimum performance. The filter parameters are controlled by a two digit number. The first digit defines the amount of filtering applied to the display as shown below.

First digit	Filter time constant Seconds
0X	0
1X	1.3
2X	4.3
3X	6.5
4X	8.7
5X	11.3
6X	15.7
7X	20.9
8X	25.2
9X	31.5

The second digit defines the deviation from the displayed rate at which the filter will be overridden and the rate display will move rapidly to the new value.

Second digit	Magnitude of step change which will produce a rapid response
X0	Off
X1	1%
X2	2%
X3	4%
X4	8%
X5	12%
X6	16%
X7	24%
X8	32%
X9	64%

By careful adjustment of the two parameters a stable display with an acceptable input step response can be obtained for most applications.

During commissioning it is recommended that initially the second digit is set to 0 (off) and the first digit is adjusted to provide acceptable rate display stability. The second digit should then be increased until the selected step size is greater than the noise on the display signal, at which setting the rate display will become stable. These will be the optimum filter parameters for acceptable rate display stability and a fast response to a large rate signal change.

To check or change the filter select $F, L \& E r$ in the configuration menu and press P which will reveal the current settings with the first digit flashing. Pressing the \blacktriangledown or \blacktriangle button will adjust the flashing digit and P will transfer control to the second digit. While making adjustments the filtered rate display is shown on the lower display so that stability can be assessed while adjustments are being made. When set as required, press the E button to enter the revised parameters and return to the $F, L \& E r$ prompt in the configuration menu.

6.16 Direction of count: uP or dN

This function defines whether input pulses increment or decrement the total display. i.e. whether the BA367E-SS is an up-counter or a down-counter.

When configured as a down-counter with a non-zero number entered for the reset value $[Lr URl]$, the BA367E-SS will count down from the reset value to zero.

To check or change the count direction select uP or dN from the configuration menu and press P which will reveal the present setting. uP indicates that the instrument is an up-counter and dN that it is a down counter. Pressing the \blacktriangledown or \blacktriangle buttons will toggle the instrument between the two settings. When set as required, press the E button to enter the setting and return to the configuration menu.

6.17 Reset value: $[Lr URl]$

This function defines the value to which the total display is reset when the local or remote reset are operated. This allows the BA367E-SS to be used as a preset down-counter.

When the instrument is used as an up-counter, $[Lr URl]$ is normally set to zero.



To check or change the reset value select $[Lr URl]$ from the configuration menu and press P which will reveal the current setting with one digit flashing. The flashing digit may be adjusted by pressing the \blacktriangledown or \blacktriangle button. When this digit is correct, pressing P will transfer control to the next digit.







When all the digits have been adjusted press the E button to enter the revised number and return to the configuration menu.

6.18 Local reset: $Lo[LR]$

The Local reset function contains two sub-functions $[Lr Tot]$ and $[Lr Gtot]$ which when enabled allow the total display and grand total to be reset via the instrument front panel push buttons while the BA367E-SS Counter is in the display mode.

6.19 Local total reset: [Lr Tot

[Lr Tot is a sub-menu in the Loc [Lr function. When activated it allows an operator to reset the total display to the reset value [see section 6.17] while the BA367E-SS Counter is in the display mode by operating the  and  push buttons simultaneously for more than three seconds.



To check or change the setting select Loc [Lr in the configuration menu and press  which will reveal the [Lr Tot prompt, operating  again will show if the local total reset is on or off. If set as required operate the  button twice to return to the configuration menu, or the  or  button to change the setting followed by the  button twice to enter the change and return to the Loc [Lr prompt in the configuration menu.









Note:

The total display may also be remotely reset to the reset value by connecting terminals RS1 and RS2 together for more than one second. See sections 3.6; 4.1.8 and 4.2.8 of this manual.

6.20 Local grand total reset: [Lr Gtot

The grand total is a separate sixteen digit counter which is incremented or decremented in parallel with the total display, but is not reset when the total display is reset. The grand total may be viewed in the display mode in two eight digit sections as described in section 2.2 of this manual.

[Lr Gtot is a sub-menu in the Loc [Lr function which when activated allows the operator to reset the grand total display to zero from the display mode by operating the  and  push buttons simultaneously for more than ten seconds.









To check or change setting select Loc [Lr in the configuration menu and press  which will reveal [Lr Tot. Using the  or  button select [Lr Gtot and press  which will show if local grand total reset is on or off. If set as required operate the  button twice to return to the configuration menu, or the  or  button to change the setting followed by the  button twice to enter the change and return to the Loc [Lr prompt in the configuration menu.

Note:

Once reset, the grand total can not be recovered.

6.21 Reset grand total from configuration menu: [Lr Gtot

The grand total is a separate sixteen digit counter which is incremented or decremented in parallel with the total display, but is not reset when the total display is reset. The grand total may be viewed in the display mode in two eight digit sections as described in section 2.2 of this manual.





To zero the grand total from within the configuration menu select [Lr Gtot and press  which will cause the instrument to display [Lr .no with no flashing. Using the  or  push button change [Lr no to [Lr 5E5 pressing  will result in the instrument displaying 0000 with the first digit flashing. This is a request to confirm the reset instruction by entering 5urE. Using the  or  button set the first flashing digit to 5 and press  to transfer control to the second digit which should be set to u. When 5urE has been entered pressing the  button will reset the grand total which will be confirmed by a brief display of Gt [Lrd, the instrument will automatically return to the [Lr Gt prompt in the configuration menu.

Note:

Once reset, the grand total can not be recovered.

6.22 Security code: [odE

Access to the instrument configuration menu may be protected by a four digit security code which must be entered to gain access. New instruments are configured with the default security code 0000 which allows unrestricted access to all configuration functions.

To enter a new security code select [odE from the configuration menu and press  which will cause the BA367E-SS Counter to display 0000 with one digit flashing. The flashing digit may be adjusted using the  and  push buttons, when set as required operating the  button will transfer control to the next digit. When all the digits have been adjusted press  to return to the [odE prompt. The revised security code will be activated when the BA368E Counter is returned to the display mode.

Please contact BEKA associates sales department if the security code is lost.

6.23 Reset configuration to factory defaults:

r5Et dEF

This function returns the BA367E-SS Counter to the factory defaults shown in section 6.0. To prevent accidental use the request must be confirmed by entering 5urE before the configuration change will be executed.

Select r5Et dEF from the configuration menu and press **P** the instrument will display 0000 with the first digit flashing. To confirm the instruction to reset all the configuration functions to factory defaults 5urE must be entered. Using the **▼** or **▲** button set the first flashing digit to 5 and press **P** to transfer control to the second digit which should be set to u. When 5urE has been entered pressing the **E** button will reset all the configuration functions to the factory default settings and zero both the total display and the grand total. While resetting the BA367E-SS Counter will display - - - - - before automatically returning to the display mode when the operation is complete.

6.24 Display overflow

The BA367E-SS Counter total has a maximum display range of -9999999 to 99999999 when shown on the eight digit upper display. If this range is exceeded the display will be as shown below with all of the decimal points flashing:

Underrange	-9.9.9.9.9.9
Overrange	9.9.9.9.9.9.9

When the total is shown on the lower six digit display the maximum display range is -99999 to 999999.

When a total overflow occurs the actual total may be obtained from the instrument's grand total display which has sixteen digit - see 2.3.

To prevent future total display overflows occurring the total scale factor 5rLE.t and the position of the decimal point in the total display dP should be reviewed.

7. CONFIGURATION EXAMPLE

A BA367E-SS Counter is required to display the total number of strokes that a reciprocating pump makes in thousands of strokes on the larger upper display and to show the speed of pumping in strokes per hour on the lower display. The stroke sensor is a proximity detector which produces four pulses per stroke. The total display is only to be resettable by an external contact, not from the BA367E-SS Counter front panel. Similarly the grand total is not to be resettable from the BA367E-SS Counter front panel. To simplify reading the BA367E-SS display is to be updated every 3 seconds and to prevent tampering the instrument configuration menu is to be protected by security code 1209.

The BA367E-SS may be configured on-site without disconnection from the power supply or from the proximity detector. This example assumes that the BA367E-SS initially has default factory configuration.

If after accessing the configuration menu the interval between operating any front panel push button exceeds one minute the BA367E-SS will automatically return to the display mode and any configuration changes will not be stored in permanent memory. When making multiple changes it is therefore sensible to occasionally return to the display mode to save the changes that have already been made.

Step 1 Enter the configuration menu

Put the BA367E-SS Counter in the configuration mode by simultaneously pressing the **P** and **E** push buttons. Assuming a security code has not already been entered the instrument will respond by displaying ,nPvt which is the first parameter in the configuration menu. See Fig 13.

Step 2 Select the type of inputs

With ,nPvt displayed; press **P** to reveal the ,nPvt.tYPE submenu and press **P** again to enter the function. Using the **▼** or **▲** button select PrdEt, the input for a 2-wire proximity detector and then return to the ,nPvt prompt in the configuration menu by pressing **E** twice. A proximity detector requires energising therefore terminals 3 and 4 of the BA367E-SS should be linked together.

Step 3 Select display update

To aid reading the display the BA367E-SS is only to be updated every 3 seconds.

Select `uPdRE` from the configuration menu and press `[P]`. Using the `[▼]` or `[▲]` button select `3` and press `[E]` to return to the `uPdRE` prompt in the configuration menu.

Step 4 Define function of upper display

In the example the total number of strokes is required on the larger eight digit upper display.

Select `d, 5P-1` from the configuration menu and press `[P]` which will reveal if the upper display is showing `rRE` or `taRL`. Using the `[▼]` or `[▲]` button select `taRL` followed by the `[E]` button to enter the selection and return to the configuration menu.

Step 5 Activate lower rate display

A rate display is required so the lower display must be activated.

Select `d, 5PLRY.2` from the main menu and press `[P]` to show the existing setting. Using the `[▼]` or `[▲]` button select `on` followed by `[E]` to enter the selection and return to the configuration menu.

Step 6 Position of decimal point

In this example the BA367E-SS is required to display total and rate with no decimal points.

Select `dP.` from the configuration menu and press `[P]`. The BA367E-SS will show and identify the total display with all the digits activated. Using the `[▼]` or `[▲]` button position the decimal point to the right of the least significant digit i.e. not visible.

Operating the `[P]` button will show and identify the rate display with all the digits activated. Again using the `[▼]` or `[▲]` button position the decimal point to the right of the least significant digit i.e. not visible.

Finally press `[E]` to return to the configuration menu.

Step 7 Enter the total scale factor

In this example the proximity detector produce four pulses per pump stroke. The BA367E-SS is required to display thousands of pump strokes therefore the total scale factor `5[RE]` should be set to $(4 \times 1000) = 4000$.

Select `5[RE]` from the configuration menu and press `[P]` to view the current value with one digit flashing. Use the `[▼]` or `[▲]` button to adjust the flashing digit and the `[P]` button to transfer control to the next digit and to the decimal point. Enter `40000` and return to the `5[RE]` prompt in the configuration menu by pressing `[E]`.

Step 8 Enter the rate scale factor

The proximity detector produces four pulses per pump stroke and the rate display is required in strokes per hour, therefore the rate scale factor `5[REr]` should be set to 4.0.

Select `5[REr]` from the configuration menu and press `[P]` to view the current value with one digit flashing. Use the `[▼]` or `[▲]` button to adjust the flashing digit and the `[P]` button to transfer control to the next digit and to the decimal point. Enter `40` and return to the `5[REr]` prompt in the configuration menu by pressing `[E]`.

Step 9 Set the display timebase

In this example the rate display is required in pump strokes per hour.

Select `t-brSE` from the configuration menu and press `[P]` to reveal the current setting. Using the `[▼]` or `[▲]` button scroll through the three options and select `tB-3600`. Return to the `t-brSE` prompt in the configuration menu by pressing `[E]`.

Step 10 Adjust the rate display filter

The rate display filter parameters should be adjusted experimentally after installation to provide a stable rate display with an acceptable step response.

During commissioning it is recommend that initially the second digit of the rate parameters is set to 0 (step response off) and the first digit (amount of filtering) is adjusted to provide acceptable rate display stability.

The second digit should then be increased until acceptable rate display stability is once again achieved.

To adjust the filter parameters select `F,LTtEr` from the main menu and press `[P]` to reveal the current setting. The first digit will be flashing and may be adjusted using the `[▼]` or `[▲]` button. The `[P]` button will transfer control to the second digit. When both are set as required, return to the `F,LTtEr` prompt in the configuration menu by pressing `[E]`.

Note: While adjusting the filter, the rate is shown on the lower display so that stability can be assessed.

Step 11 Define the security code

Defining an access security code prevents unauthorised access to the configuration menu. Select `[odE]` in the configuration menu and press `[P]` which will reveal the existing security code with the first digit flashing. Enter the new code 1209 using the `[▼]` or `[▲]` button to adjust the flashing digit and the `[P]` button to transfer control to the next digit. When the new code has been entered, press `[E]` to return to the configuration menu.

Step 12 Return to the display mode

Following completion of configuration, return the BA367E-SS to the display mode by pressing `[E]`. The instrument will display `dRtR` followed by `SRUE` while the configuration changes are stored in permanent memory.

The BA367E-SS was assumed to initially have factory default configuration, therefore the counting edge, counting direction, local total and local grand total resets were not reconfigured as they already complied with the requirements for this example.

During commissioning the debounce and filter functions may need adjustment to obtain a stable display.

8. MAINTENANCE

8.1 Fault finding during commissioning

If a BA367E-SS Counter fails to function during commissioning the following procedure should be followed:

Symptom	Cause	Check:
No display	No power supply, or incorrect wiring. Note: Terminals 2, 6 & RS2 are interconnected within the instrument.	That there is between 10 and 28V on terminals 1 & 2 with terminal 1 positive.
Counter is receiving power but pulse input indicator not rotating.	No input pulses, incorrect input configuration, incorrect linking of terminals 3 & 4.	Input configuration. Linking of terminals 3 & 4. That input signal polarity is correct.
Pulse input indicator rotating but incorrect rate display.	Incorrect rate display calibration	SCALE - bR5E
Pulse indicator rotating but incorrect total display.	Incorrect total display calibration. Remote reset switch contacts closed.	SCALE That RESET annunciator is not activated. If it is, check reset wiring and switch.
Unstable rate display	Noisy pulse input signal	Eliminate source of electrical noise. Increase debounce and/or display filter.
Unable to enter configuration menu.	Incorrect security code	That the correct security code is being used. Contact BEKA if code is lost.
Optional 4/20mA or pulse output do not function	Output has been disabled following configuration change	Re-enable output
Optional alarms do not function	Alarms have been disabled following configuration change.	Re-enable both alarms.

8.2 Fault finding after commissioning

ENSURE PLANT SAFETY BEFORE STARTING MAINTENANCE

Live maintenance is permitted on intrinsically safe equipment installed in a hazardous area, but only certified test equipment should be used unless a gas clearance certificate is available.

If a BA367E-SS Counter fails after it has been functioning correctly, the following table may help to identify the cause of the failure.

Symptom	Cause	Check:
No display	No power supply.	That there is between 10 and 28V on terminals 1 & 2 with terminal 1 positive
Pulse input indicator not rotating.	No input pulses	Output from sensor. Wiring between sensor and BA367E-SS Counter.
Unstable rate display	Noisy pulse input signal	Locate source of electrical noise, or increase debounce and rate display filter.

If this procedure does not reveal the cause of the fault, it is recommended that the instrument is replaced.

8.3 Servicing

We recommend that faulty BA367E-SS Counters are returned to BEKA associates or to our local agent for repair.

8.4 Routine maintenance

The mechanical and electrical condition of the instrument should be regularly checked. Inspection frequency should be adjusted to suit the environmental conditions.

8.5 Guarantee

Instruments which fail within the guarantee period should be returned to BEKA associates or our local agent. It is helpful if a brief description of the fault symptoms is provided.

8.6 Customer comments

BEKA associates is always pleased to receive comments from customers about our products and services. All communications are acknowledged and whenever possible, suggestions are implemented.

9. ACCESSORIES

Accessories for the BA367E-SS Counter are shown below, all except the scale card are factory fitted and should be specified when the instrument is ordered:

- Scale card
- Tag number
- Backlight ¹
- Isolated pulse output ²
- or
- Isolated 4/20mA output ²
- or
- Isolated dual alarms ²

Notes:

1. Internally powered
2. Only one of the three output options can be fitted to a BA367E-SS.

9.1 Scale card

The BA367E-SS has a window on the right hand side of the display through which to view a scale card showing the units of measurement such as Strokes or Metres. New Counters are fitted with a scale card showing the units of measurement specified when the instrument was ordered, if the units are not specified a blank scale card will be fitted. A pack of scale cards pre-printed with common units of measurement is available as an accessory. These can easily be fitted on-site to the Counter without opening the instrument enclosure or removing it from the panel, See section 5.5 of this instruction manual.

Custom scale cards for applications requiring less common units of measurement are also available.

9.2 Tag information

A tag number or application information can the laser etched onto the rear panel adjacent to the terminals. This information is not visible from the front of the instrument after installation.

9.3 Alarms

Only one of the following accessories may be fitted: dual alarms, pulse output or 4/20mA output.

The BA367E-SS Counter can be supplied with factory fitted dual solid state single pole alarm outputs that may be independently configured as high or low, rate or total alarms with normally open or normally closed outputs.

Configurable functions for each alarm include adjustable setpoint, alarm delay time and alarm silence time. Hysteresis may be applied to rate alarms.

WARNING

Alarm outputs should not be used for critical safety applications such as a shut down system.

When the BA367E-SS power supply is turned off or disconnected, alarm outputs will open irrespective of whether normally open or normally closed outputs have been selected. When designing a system an open output should therefore be chosen for the alarm condition.

Alarm annunciators on the instrument display indicate the status of each alarm. If an alarm delay or silence time has been selected the annunciator will flash during the delay or silence period.

The BA367E-SS internal counters are up-dated and compared with the alarm setpoint twice per second, irrespective of the display update time selected. This may result in an alarm being delayed for up to half a second after the rate or total has exceeded the setpoint.

9.3.1 Solid state output

Each alarm has a galvanically isolated single pole solid state switch output as shown in Fig 14. The outputs are polarised and current will only flow in one direction. Terminals A1 and A3 should be connected to the positive side of the supply.

$$\begin{aligned} R_{on} &= \text{less than } 5\Omega + 0.7V \\ R_{off} &= \text{greater than } 1M\Omega \end{aligned}$$

Note: Because of the series protection diode some test meters may not detect a closed alarm output

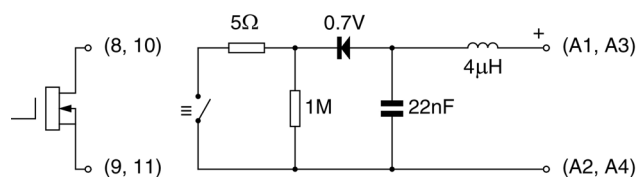

Fig 14 Equivalent circuit of each alarm output

9.3.2 Intrinsic safety

Each alarm output is a separate galvanically isolated intrinsically safe circuit with output safety parameters complying with the requirements for *simple apparatus*. This allows the alarm output terminals A1 & A2 and A3 & A4 to be connected to almost any intrinsically safe circuit protected by a Zener barrier or galvanic isolator providing the output parameters of the circuit do not exceed:

$$\begin{aligned} U_o &= 28V \text{ dc} \\ I_o &= 200mA \\ P_o &= 0.84W \end{aligned}$$

The maximum equivalent capacitance and inductance between each set of alarm terminals is:

$$C_i = 22\text{nF}$$

$$L_i = 8\mu\text{H (Effectively 0)}$$

To determine the maximum permissible cable capacitance C_i should be subtracted from the maximum permitted external capacitance C_o specified by the certificate for the intrinsically safe interface powering the alarm circuit, such as the solenoid driver and switch transfer galvanic isolators shown in Fig 15.

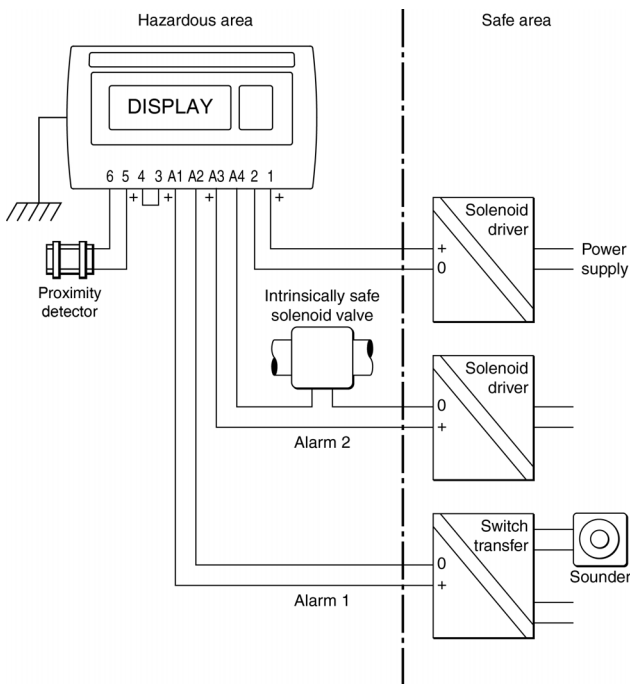

Fig 15 Typical alarm application

9.3.3 Configuration summary

When a BA367E-SS Counter is supplied with alarms the configuration menu is extended as shown in Fig 16. Each alarm may be configured to operate on the rate or total display.

For simplicity Fig 16 only shows the configurable functions on the rate option of alarm AL1, the total options is identical except that the total alarms can not have hysteresis. Configuration of alarm AL2 is identical to alarm AL1.

The following table summarises each of the alarm configuration functions and includes a cross reference to more detailed information. Again only the functions on alarm AL1 are listed.

Display	Summary of function
EnbL	Alarm enable Enables or disables the alarm without changing the alarm parameters. See section 9.3.4
tYPE	Type of alarm Defines whether the alarm operates on the rate or total display. See section 9.3.5
5P Ir or 5P It	Alarm setpoint 1 Adjusts the alarm setpoint. The alarm is activated when the rate or total display equals the setpoint. Note: 5P Ir is displayed for a rate alarm and 5P It for a total alarm. See section 9.3.6
Hi.Lo	Alarm function Defines whether the alarm has a high or low function. See section 9.3.7
no.nC	Normally open or normally closed output. Determines whether the single pole alarm output is open or closed in the non-alarm condition. See section 9.3.8
H5Er	Hysteresis Adjusts the alarm hysteresis. Only available on a rate alarm. See section 9.3.9
dELA	Alarm delay time Adjusts the delay between the display equalling the alarm setpoint and the alarm output being activated. See section 9.3.10
5r.L	Alarm silence time Defines the time that the alarm output remains in the non-alarm condition following acceptance of an alarm. See section 9.3.11
FL5H	Flash display when alarm occurs When enabled, alternates the rate or total display between process value and alarm reference $RL1$ or $RL2$ when an alarm output is activated. See section 9.3.12
RC5P	Access setpoint Sub-menu that enables direct access to the alarm setpoints from the display mode and defines a separate security code. See section 9.3.13

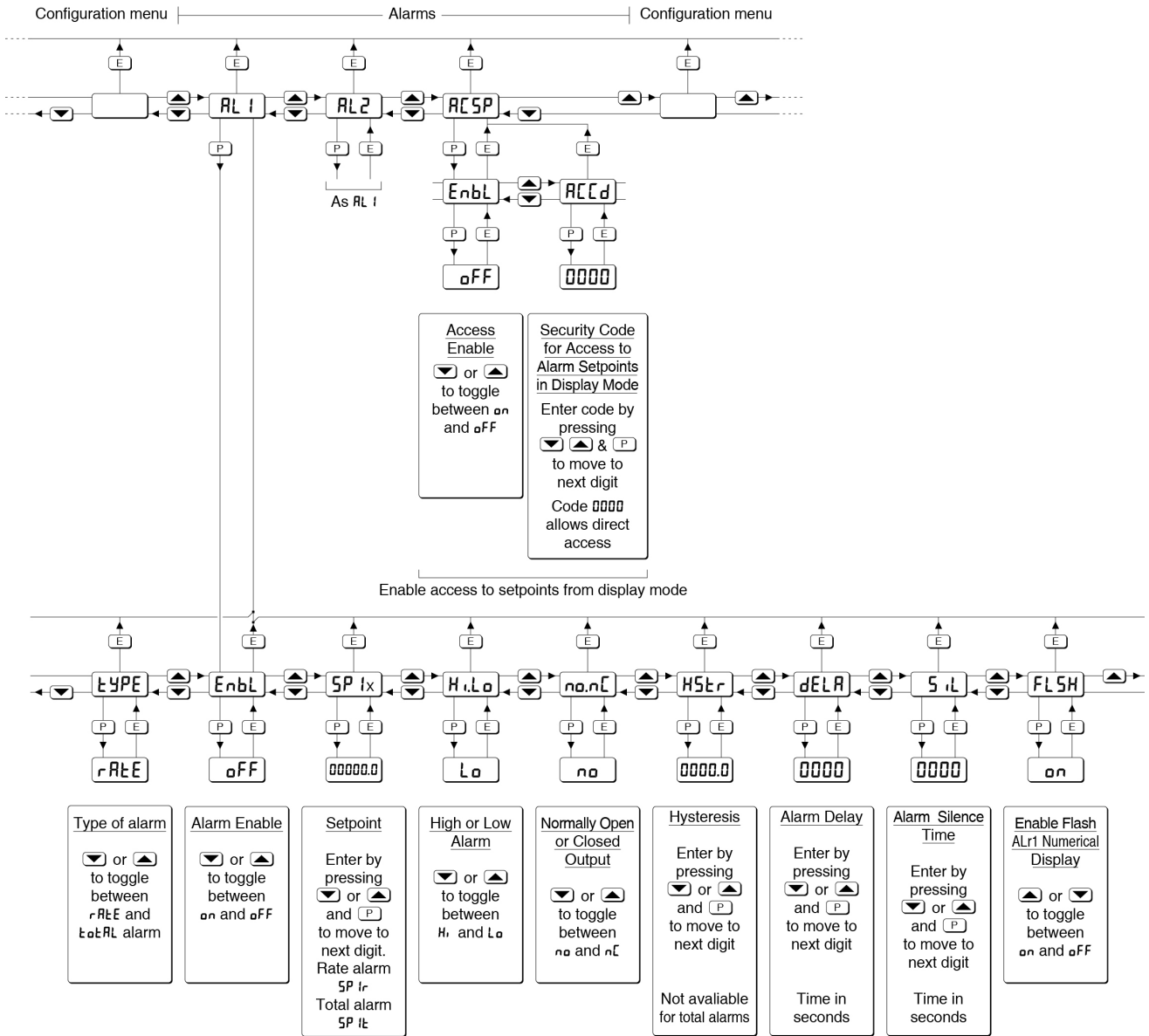

Fig 16 Alarm Configuration Functions in Configuration Menu

9.3.4 Alarm enable: EnbL

This function allows the alarm to be enabled or disabled without altering any of the alarm parameters. Using the ▼ or ▲ push button select AL 1 or AL 2 from the configuration menu and press P to reach EnbL in the alarm sub-menu. Pressing P will then reveal the existing setting. The function can be changed by pressing the ▼ or ▲ push button followed by the E button to return to the alarm sub-menu.

9.3.5 Type of alarm: TYPE

Alarm 1 and Alarm 2 are totally independent, both may be rate or total alarms, or one may be conditioned for rate and the other for total. Using the ▼ or ▲ push button select TYPE from the selected alarm sub-menu and press P to check or change the function. The ▼ or ▲ push button will toggle the selection between rALtE and tALtRL, when set as required press the E button to return to the alarm sub-menu.

Note: When TYPE is changed, the alarm configuration is automatically reset to the default values and the alarm is disabled. It must therefore be reconfigured before use.

9.3.6 Setpoint adjustment: 5P1r & 5P2r

The rate alarm setpoints 5P1r and 5P2r may be positioned anywhere between -99999 and 999999, and the total alarm setpoint 5P1t and 5P2t anywhere between -9999999 and 99999999.

All the setpoints are adjusted in the same way, for example, to adjust the setpoint of Alarm 1 which has been configured to operate on the rate display. Using the \blacktriangledown or \blacktriangle push button select 5P1r in the RL1 sub-menu and press P which will reveal the existing setpoint with one digit flashing. The required setpoint can be entered using the \blacktriangledown or \blacktriangle push button to adjust the flashing digit and the P button to transfer control to the next digit. When set as required press E to enter the value and return to the 5P1r prompt in the alarm 1 sub-menu.

9.3.7 Alarm function: Hi.Lo

Alarm 1 and Alarm 2 are totally independent, both may be Hi or Lo, or one may be conditioned as a Hi alarm and the other as a Lo alarm.

Using the \blacktriangledown or \blacktriangle push button select Hi.Lo from the selected alarm sub-menu and press P to check or change the function. The \blacktriangledown or \blacktriangle push button will toggle the alarm function between Hi and Lo, when set as required, press the E button to return to the Hi.Lo prompt in the alarm sub-menu.

9.3.8 Alarm output status: no.nc

Each single pole alarm output may be open or closed in the non-alarm condition. When the BA367E-SS power supply is turned off or disconnected, the alarm output(s) will open irrespective of whether normally open or normally closed outputs have been selected. Therefore, when designing an alarm system normally closed nc should be selected so that the output opens when an alarm occurs or if the power supply fails.

Using the \blacktriangledown or \blacktriangle push button select no.nc from the selected alarm sub-menu and press P to check or change the function. The \blacktriangledown or \blacktriangle push button will toggle the contact status between no and nc, when set as required, press the E button to return to the no.nc prompt in the alarm sub-menu

9.3.9 Hysteresis: H5tr

Hysteresis is only available on rate alarms so the H5tr function only appears in the configuration sub-menu when alarm TYPE has been set to RATE. During configuration hysteresis is shown in the units of rate previously configured for the rate display.

Using the \blacktriangledown or \blacktriangle push button select H5tr in the selected alarm sub-menu and press P which will reveal the existing hysteresis with one digit flashing.

The required hysteresis can be entered using the \blacktriangledown or \blacktriangle push button to adjust the flashing digit and the P button to transfer control to the next digit. When set as required press E to enter the value and return to the H5tr prompt in the alarm sub-menu.

e.g. A BA367E-SS Counter configured to display a rate of 0 to 5000, with a high alarm set at 4000 and hysteresis of 100 will perform as follows:

High alarm will be activated when rate equals or exceeds 4000, but will not reset until the rate falls below 3900.

9.3.10 Alarm delay: dELR

This function enables activation of the alarm output to be delayed for a fixed time following the alarm condition occurring. The delay can be set in 1 second increments up to 3600 seconds. If a delay is not required zero should be entered.

To adjust the delay select dELR using the \blacktriangledown or \blacktriangle push button in the selected alarm sub-menu and press P which will reveal the existing delay time in seconds with one digit flashing. The required delay time can be entered using the \blacktriangledown or \blacktriangle push button to adjust the flashing digit and the P button to transfer control to the next digit. When set as required press E to enter the value and return to the dELR prompt in the alarm sub-menu.

The alarm annunciator will start flashing immediately an alarm occurs and will continue for the delay time, after which the alarm output will be activated and the alarm annunciator will be permanently activated.

9.3.11 Alarm silence time: S, L

The alarm silence function is primarily intended for use in small installations where the alarm output directly operates an annunciator such as a sounder. When the alarm silence time is set to any figure other than zero, the P push-button becomes an alarm accept button.

After an alarm has occurred, operating the P button will cause the alarm output to revert to the non-alarm condition for the alarm silence time. When an alarm is silenced the alarm annunciator will flash until the silence time expires.

To adjust the alarm silence time select S, L using the \blacktriangledown or \blacktriangle push button in the selected alarm sub-menu and press P which will reveal the existing alarm silence time in seconds with one digit flashing. The required silence time can be entered using the \blacktriangledown or \blacktriangle push button to adjust the flashing digit and the P button to transfer control to the next digit. When set as required press E to enter the value and return to the S, L prompt in the alarm sub-menu.

9.3.12 Flash display when alarm occurs: FL5H

In addition to the two alarm annunciators on the left hand side of the BA367E-SS Counter display which show the status of both alarms, this function provides an even more conspicuous indication that an alarm condition has occurred.

When enabled, this function alternates the rate or total display between the numerical value and the alarm identification $RL1$ or $RL2$ when an alarm occurs.

Using the \blacktriangledown or \blacktriangle push button select FL5H from the selected alarm sub-menu and press P to check or change the function. The \blacktriangledown or \blacktriangle push button will toggle the function between OFF and ON , when set as required, press the E button to return to the FL5H prompt in the alarm sub-menu.

9.3.13 Access Setpoint: RLS5P

This function activates a separate menu that provides direct access to the alarm setpoints from the display mode by simultaneously operating the P and \blacktriangle buttons. An operator can therefore adjust the alarm setpoints without having access to the configuration and alarm sub-menus. Protection against unauthorised or accidental adjustment is provided by a separate security access code.

Using the \blacktriangledown or \blacktriangle push button select RLS5P from the configuration menu and press P to reach the enable function ENBL . Pressing P will reveal the existing setting which can be toggled between ON and OFF by pressing the \blacktriangledown or \blacktriangle push button. When set as required, press the E button to return to the ENBL prompt from which a separate security access code can be entered using the RLCD function which can be selected using the \blacktriangledown or \blacktriangle push button.

To enter a new security code select RLCD from the sub-menu and press P which will cause the BA367E-SS Counter to display 0000 with one digit flashing. The flashing digit may be adjusted using the \blacktriangledown and \blacktriangle push buttons, when set as required operating the P button will transfer control to the next digit. When all the digits have been adjusted press E to return to the RLCD prompt. The revised security code will be activated when the BA367E-SS Counter is returned to the display mode. Default security access code 0000 will disable the security code allowing direct access to the setpoints in the display mode by pressing the P and \blacktriangle buttons simultaneously.

Please contact BEKA associates sales department if the security code is lost.

9.3.14 Adjusting alarm setpoints from the display mode

Access to the two alarm setpoints from the BA367E-SS Counter's display mode is obtained by operating the P and \blacktriangle push buttons simultaneously as shown in Fig 17. If the setpoints are not protected by a security code the alarm setpoint prompt $SP1r$ or $SP1t$ will be displayed depending upon whether a rate or total alarm has been configured. If the setpoints are protected by a security code, CodE will be displayed first. Pressing P again will allow the alarm setpoint security code to be entered digit by digit using the \blacktriangledown or \blacktriangle button to adjust the flashing digit and the P push button to move control to the next digit. If the correct code is entered pressing E will then cause alarm setpoint prompt $SP1x$ to be displayed. If an incorrect security code is entered, or a button is not pressed within ten seconds, the instrument will automatically return to the display mode.

Once within the menu pressing the \blacktriangledown or \blacktriangle buttons will toggle the display between the two alarm setpoint prompts $SP1x$ and $SP2x$.

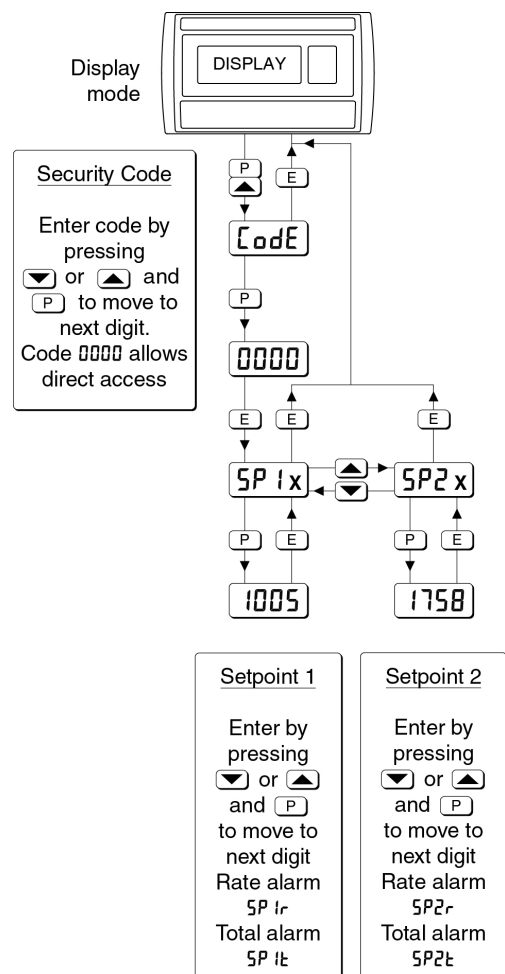

Fig 17 Setpoint adjustment from the display mode

To adjust an alarm setpoint select $5P\ 1x$ or $5P\ 2x$ and press P which will reveal the current setting. The flashing digit of the setpoint may be adjusted using the \blacktriangledown and \blacktriangle push buttons and the P button to move control to the next digit. When the required setpoint has been entered, pressing E will return the display to the $5P\ 1x$ or $5P\ 2x$ prompt from which the other setpoint may be selected, or the instrument may be returned to the display mode by pressing E again.

Note: Direct access to the alarm setpoints from the display mode is only available when the $AL5P$ menu is enabled - see section 9.3.13

9.4 Pulse output

Only one of the following accessories may be fitted: dual alarms, pulse output or 4/20mA output.

The BA367E-SS Counter can be supplied with a factory fitted opto-isolated solid state pulse output. The output is an open collector having the following electrical parameters:

R_{on}	=	$60\Omega + 3V$
R_{off}	=	1M
I_{max}	=	10mA

The output pulse may be a duplicate of the input pulse for re-transmission applications, or it may be derived from the total display. When derived from the total display the output pulse frequency may be divided and the output pulse width defined.

9.4.1 Intrinsic safety

The pulse output is an optically isolated separate intrinsically safe circuit that has zero output safety parameters. The output therefore complies with the requirements *for simple apparatus*. This allows pulse output terminals P1 and P2 to be directly connected to any intrinsically safe circuit protected by a certified Zener barrier or galvanic isolator providing the output parameters do not exceed:

U_o	\leq	28V dc
I_o	\leq	200mA dc
P_o	\leq	0.84W

The equivalent capacitance and inductance of the pulse output are both zero which allows the maximum permissible cable parameters specified by the certificate for the Zener barrier or galvanic isolator powering the pulse output circuit to be used.

9.4.2 System design

The BA367E-SS Counter pulse output is a passive circuit i.e. not powered, but it is totally isolated from all other Counter circuits. Subject to complying with intrinsic safety interconnection requirements, the terminals P1 and P2 may be connected to another instrument with a open collector input. The pulse output may also be transferred to the safe area via a galvanic isolator or a Zener barrier.

Fig 18 shows how Zener barriers may be used to produce a voltage pulse in the safe area that could be used to drive a safe area counter. The positive terminal of the pulse output circuit P1 is connected to the BA367E-SS Counter's positive supply terminal 1 at the instrument. When an output pulse occurs and the open collector output 'closes', P2 is connected to P1 and a pulse current flows through the diode return barrier and R1 in the safe area. The current flowing in the circuit is determined by resistor

R1 which should be chosen to limit the pulse output current to less than 10mA. For a 24V supply R1 should be greater than 2,200Ω.

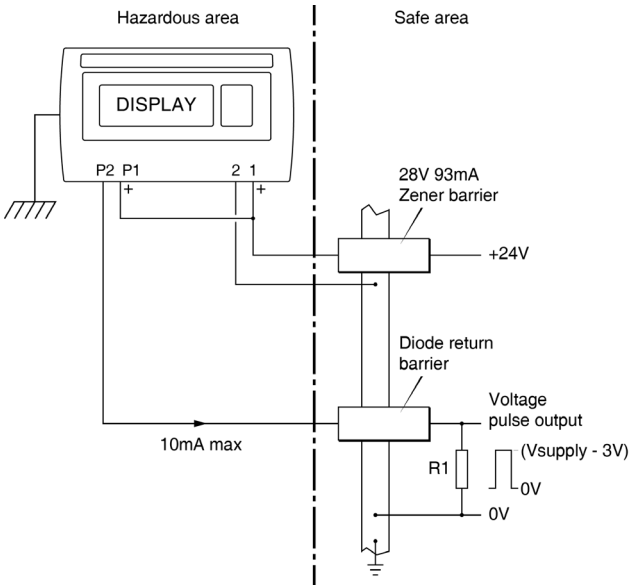

Fig 18 Transferring pulse output to safe area using Zener barriers

9.4.3 Configuration

When a BA367E-SS Counter is supplied with an optional pulse output the configuration menu is extended as shown in Fig 19.

The pulse output sub-menu allows the source of the output pulse to be selected in the *Source* sub-function. For re-transmission applications the output pulse may be a synchronous duplicate of the input pulse by selecting *direct* in the *Source* sub-function.

Selecting *Scaled* derives the output pulse from the total display and introduces two additional functions, *divide* and *duration*, to the sub-menu allowing the output pulse frequency to be divided and the output pulse width (duration) to be defined. The total display is read every half second and any increase since the last reading copied into the pulse output counter. After dividing by the *divide* function, pulses of width defined by the *duration* function are asynchronously output from this counter as quickly as possible.

If the *divide* and *duration* functions are configured such that the output pulse frequency with the specified pulse width can not be output in real time, the number of pulses will be stored and transmitted at the maximum possible speed.

When the total display is reset to zero or the power supply to the BA367E-SS Counter is disconnected or turned off, any stored pulses will not be retained

9.4.4 Access Pulse output sub-menu: *PULSE oP*

Access to the BA367E-SS Counter configuration menu as described in section 6.2. Using the \blacktriangledown and \blacktriangle push buttons scroll through the menu until *PULSE oP* is displayed, pressing P will then access the pulse output sub-menu which is shown in Fig 19.

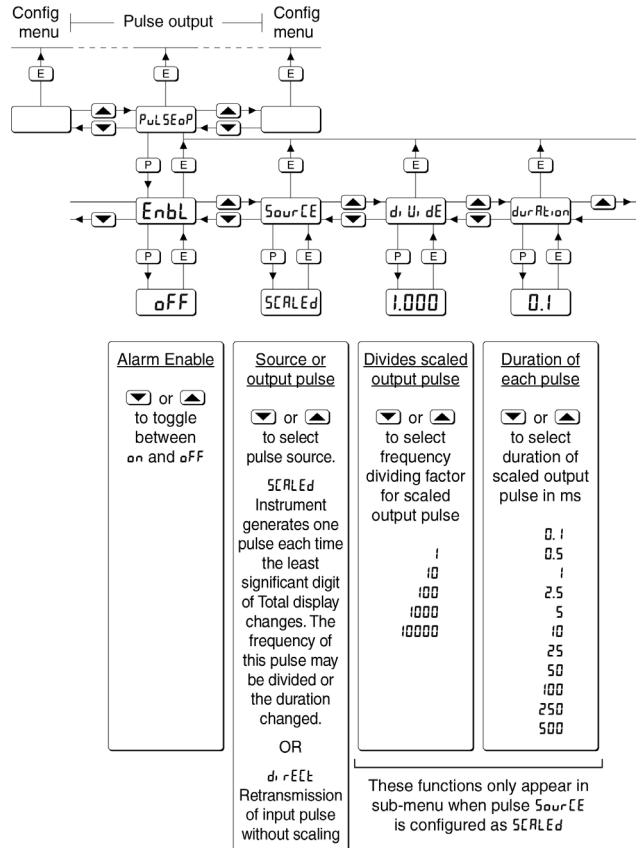

Fig 19 Pulse output configuration sub-menu

9.4.5 Enable pulse output: *EnbL*

This function allows the pulse output to be disabled or enabled without altering any of the pulse output parameters. Using the \blacktriangledown or \blacktriangle push button select *EnbL* in the pulse output sub-menu and press P . to reveal the existing setting on or off. The function can be changed by pressing the \blacktriangledown or \blacktriangle push button followed by the E button to return to *EnbL* prompt.

9.4.6 Source of pulse output: *SOURCE*

The output pulse may be derived from:

<i>direct</i>	Output is a duplicate of the input pulse.
<i>SCALEd</i>	Output is derived from the total display. When <i>SCALEd</i> is selected two additional functions, <i>diviDE</i> and <i>duration</i> , appear in the pulse output sub-menu.

Using the \blacktriangledown or \blacktriangleleft push button select *SOURCE* in the pulse output sub-menu and press P to reveal the existing pulse source. The function can be changed by pressing the \blacktriangledown or \blacktriangleleft push button followed by the E button to return to *SOURCE* prompt.

9.4.7 Divide output pulse frequency: *diviDE*

When the output pulse is derived from the total display the output pulse frequency may be divided by:

1
10
100
1000
10000

Using the \blacktriangledown or \blacktriangleleft push button select *diviDE* in the pulse output sub-menu and press P to reveal the existing divisor. The value can be changed by pressing the \blacktriangledown or \blacktriangleleft push button to select the required value followed by the E button to return to *diviDE* prompt.

Note: This function only appears in the sub-menu when the output pulse is derived from the total display.

9.4.8 Output pulse width: *duration*

When the output pulse is derived from the total display, the pulse width is defined by this function. One of 11 pulse widths may be selected in milliseconds:

0.1
0.5
1
2.5
5
10
25
50
100
250
500

Using the \blacktriangledown or \blacktriangleleft push button select *duration* in the pulse output sub-menu and press P to reveal the existing pulse duration. The value can be changed by pressing the \blacktriangledown or \blacktriangleleft push button to select the required value followed by the E button to return to *duration* prompt.

Note: This function only appears in the pulse output sub-menu when the output pulse is derived from the total display.

9.5 4/20mA output

Only one of the following accessories may be fitted: dual alarms, pulse output or 4/20mA output.

The BA367E-SS Counter can be supplied with a factory fitted galvanically isolated 4/20mA current sink which may be configured to represent the rate or total display.

9.5.1 Intrinsic safety

The 4/20mA output has been certified as a separate galvanically isolated intrinsically safe circuit complying with the requirements for *simple apparatus*. This allows terminals C1 and C3 to be connected to any intrinsically safe circuit protected by a certified Zener barrier or galvanic isolator providing the output parameters do not exceed:

- $U_o \leq 28V$ dc
- $I_o \leq 200mA$ dc
- $P_o \leq 0.84W$

The maximum equivalent capacitance and inductance of the 4/20mA output is:

- $C_i = 13nF$
- $L_i = 4\mu H$

To determine the maximum permissible cable parameters, these figures should be subtracted from the maximum cable capacitance and inductance specified by the certificate for the Zener barrier or galvanic isolator powering the 4/20mA output circuit.

9.5.2 System design

The optional 4/20mA output is a passive current sink i.e. not powered, but it is totally isolated from all other Counter circuits. It is effectively a 2-wire 4/20mA transmitter requiring a minimum supply of 10V with the current being controlled by the BA367E-SS rate or total display. Subject to complying with intrinsic safety interconnection requirements, terminals C1 and C3 may be directly connected to another instrument located in the same hazardous area which will accept a 4/20mA loop powered transmitter input. The 4/20mA current may be transferred to the safe area via a galvanic isolator or Zener barriers.

Fig 20 shows how a 2-channel Zener barrier may be used to power the 4/20mA current output from the safe area, alternatively a galvanic isolator may be used.

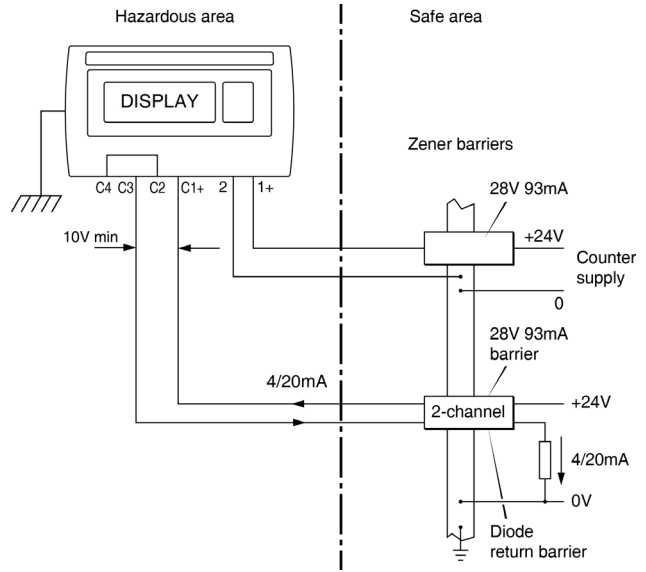

Fig 20 Application of 4/20mA output

9.5.3 Configuration

When a BA367E-SS Counter is supplied with an optional 4/20mA output the configuration menu is extended as shown in Fig 20. The 4/20mA output sub-menu is accessed via the 4-20 mA function.

The 4/20mA output sub-menu allows the 4/20mA output to be controlled by the rate or the total display.

9.5.4 Access 4/20mA output sub-menu: 4-20 mA

Access the BA367E-SS Counter configuration menu as described in section 6.2. Using the \blacktriangledown and \blacktriangle push buttons scroll through the menu until 4-20 mA is displayed, pressing P will then access the 4/20mA output sub-menu which is shown in Fig 21.

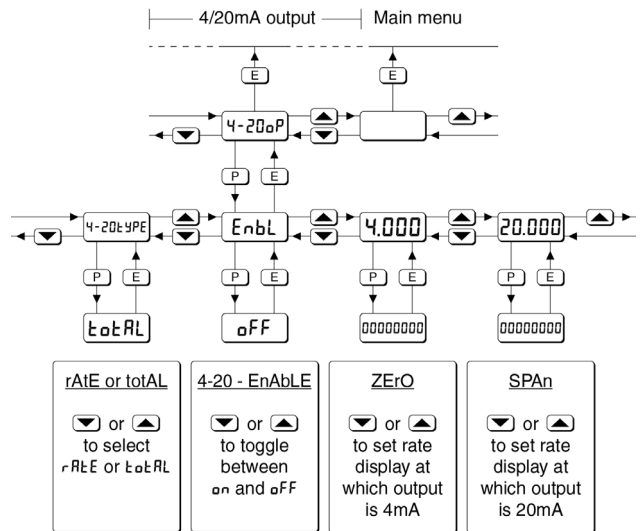

Fig 21 4/20mA output configuration sub-menu

9.5.5 Enable 4/20mA output: EnbL

This function allows the 4/20mA output to be disabled or enabled without altering any of the 4/20mA output parameters. Using the \blacktriangledown or \blacktriangle push button select EnbL in the 4-20 oP sub-menu and press P to reveal the existing setting on or oFF. The function can be changed by pressing the \blacktriangledown or \blacktriangle push button followed by the E button to return to EnbL prompt.

Note 1: When the 4/20mA output is disabled by selecting oFF, the output is a constant 3.5mA irrespective of the instrument display.

9.5.6 Select rate or total source: 4-20tYPE

The 4/20mA output current can represent the BA367E-SS Counter's rate or total display and this should be defined before any other 4/20mA current output functions are configured.

Using the \blacktriangledown or \blacktriangle push button select 4-20tYPE in the 4/20mA output sub-menu and press P to reveal the existing setting tRate or rRate. The function can be changed by pressing the \blacktriangledown or \blacktriangle push button followed by the E button to return to 4-20tYPE prompt.

Note : If the controlling source of the 4/20mA output is changed i.e. from rate to total, the 4/20mA output will be disabled and the output will be a constant 3.5mA irrespective of the instrument display. The 4/20mA output must always be re-enabled and reconfigured following the controlling source being changed.

9.5.7 Display which corresponds to 4mA output: 4.000

The BA367E-SS Counter display which corresponds to a 4.000mA output current is defined by this function. Using the \blacktriangledown or \blacktriangle push button select 4.000 in the 4/20mA output sub-menu and press P to reveal the existing rate or total display with one digit flashing. The required display can be entered using the \blacktriangledown or \blacktriangle push button to adjust the flashing digit and the P button to transfer control to the next digit. When set as required press E to enter the value and return to the 4.000 prompt in the 4/20mA output sub-menu.

9.5.8 Display which corresponds to 20mA output: 20000

The BA367E-SS Counter display which corresponds to a 20.000mA output current is defined by this function. Using the \blacktriangledown or \blacktriangle push button select 20.000 in the 4/20mA output sub-menu and press P to reveal the existing rate or total display with one digit flashing. The required display can be entered using the \blacktriangledown or \blacktriangle push button to adjust the flashing digit and the P button to transfer control to the next digit. When set as required press E to enter the value and return to the 20.000 prompt in the 4/20mA output sub-menu.

Note : If the BA367E-SS Counter and the 4/20mA current sink output are powered from separate supplies, the 4/20mA output current will continue to flow when the BA367E-SS Counter supply fails or is turned off. Powering both from a common supply eliminates this effect.

9.6 Display backlight

The BA367E-SS Counter can be supplied with a factory fitted backlight that produce green illumination enhancing display contrast and enabling it to be read at night or in poor lighting conditions. The backlight is internally powered from the instrument therefore no additional wiring or intrinsically safe interface are required, but the BA367E-SS supply current increases as shown below.

	BA367E-SS Maximum current consumption
Without backlight	10.0mA
Addition for backlight	22.5mA
Addition with terminals 3 & 4 linked	6.0mA

Total current	38.5mA max

Appendix 1 Dust certification

A1.0 ATEX dust certification

In addition to ATEX certification permitting installation in explosive gas atmospheres which is described in the main section of this instruction manual, the BA367E-SS Counter has ATEX certification permitting installation in combustible dust atmospheres.

This appendix describes ATEX installations in explosive dust atmospheres conforming with EN 60079-14 *Electrical installations design, selection and erection*. When designing systems for installation outside the UK the local Code of Practice should be consulted.

The Counter's dust input and output safety parameters are identical to its gas parameters, therefore all the electrical circuits shown in the main section of this manual may also be used for dust applications. Intrinsically safe systems in dust atmospheres only have to comply with IIB requirements. Apparatus certificates for intrinsically safe interfaces usually specify Co and Lo for IIC gases, but for use with apparatus in dust atmospheres these may be increased to the IIB figures. For a IIC interface with a Uo of 28V and an Io of 93mA, Co increases from 83nF to 650nF and Lo increases by a factor of 4 for IIB.

A1.1 Zones, and Maximum Surface Temperature

The BA367E-SS has been ATEX certified as Group II, Category 1D Ex ia IIIC T80°C Da apparatus, Ta -40 to 60°C.

When connected to a suitable system the Counter may be installed in:

- Zone 20 explosive atmosphere in the form of a cloud of combustible dust in air is continuously present, or for long periods or frequently.
- Zone 21 explosive atmosphere in the form of a cloud of combustible dust in air is likely to occur occasionally in normal operation.
- Zone 22 explosive atmosphere in the form of a cloud of combustible dust in air is not likely to occur in normal operation, but if it does occur, will only persist for a short period.

Be used with dust in subdivisions:

- IIIA combustible flyings
- IIIB non-conductive dust
- IIIC conductive dust
(For use with IIIC conductive dusts special conditions for safe use apply – see section A1.4)

Having a Minimum Ignition Temperature of:

- Dust cloud 120°C
- Dust layer on indicator up to 5mm thick 155°C
- Dust layer on indicator over 5mm thick. Refer to EN 60079-14

At an ambient temperature between -40 and +60°C

A1.3 Maintenance

ENSURE PLANT SAFETY BEFORE STARTING MAINTENANCE

Live maintenance is permitted on intrinsically safe equipment installed in a hazardous area, but only certified test equipment should be used.

The BA367E-SS has IP66 front of panel protection and a gasket is provided to seal the joint between the instrument and the mounting panel thus preventing dust ingress from the outside. The rear of the instrument has IP20 protection therefore when used in any dust application the panel enclosure in which the instrument is mounted should provide at least IP54 ingress protection. For applications in IIIC conductive dusts, IP6X protection is required.

A1.4 Special conditions for safe use

The ATEX certificate has an 'X' suffix indicating that special conditions for safe use are required for installation dust atmospheres, the certificate states:

- For use in group III explosive dust atmospheres the BA367E-SS shall be mounted such that the rear of the instrument has at least IP54 protection.
- For use in group IIIC conductive explosive dust atmospheres the BA367E-SS shall be mounted such that the rear terminals have at least IP6X protection.

A1.5 Installation in an Ex t panel enclosure within Zone 21 or Zone 22.

Installation of a BA367E-SS Counter in an Ex t IIIC panel enclosure does not invalidate the Ex t panel's certification as the front of BA367E-SS complies with Ex t impact and ingress requirements. Although mounted in an Ex t panel enclosure, the BA367E-SS remains Group II, Category 1D Ex ia IIIC T80°C Da intrinsically safe apparatus and therefore should be powered via a Zener barrier or galvanic isolator as described in section 4.1 and 4.2 of this manual.

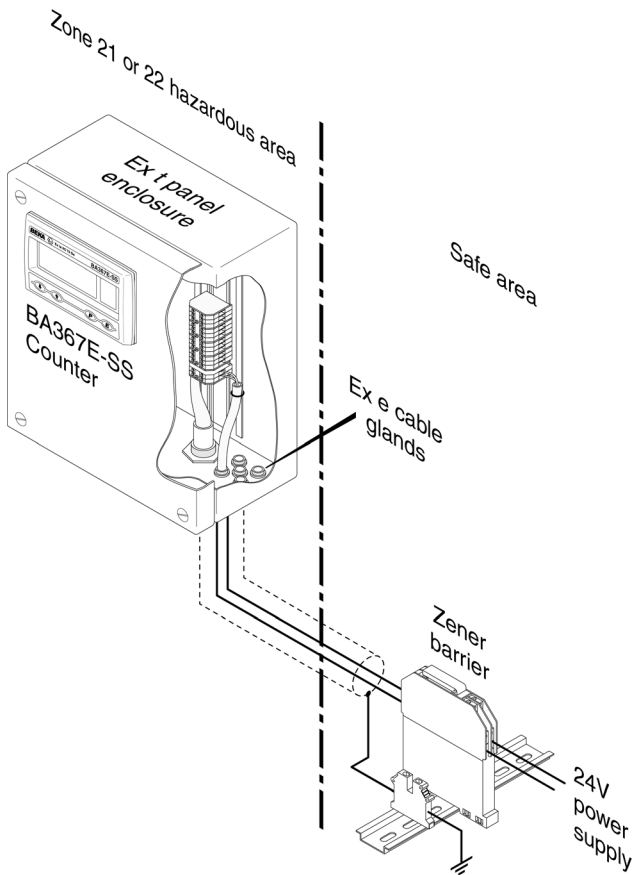

Fig 22 Typical installation in Ex t panel enclosure

The Zener barrier, galvanic isolator or associated apparatus is usually installed in the safe area, but if suitably certified may be mounted in the same Ex tc panel enclosure as the Counter for Zone 22 applications providing the surface temperature of the enclosure is not exceeded.

The Counter terminals, the wiring to the Counter and the intrinsically safe interface, if mounted within the enclosure, should be segregated from all other non-intrinsically safe wiring and equipment within the panel enclosure as required by EN 60079-11 *Equipment protected by intrinsic safety* and EN 60079-14 *Electrical installations design, selection and erection*.

If live maintenance is anticipated, it is recommended that the Ex t panel enclosure should be fitted with a warning label saying 'Do not open when non-intrinsically safe circuits are energised', alternatively all bare live non-intrinsically safe parts within the panel enclosure should have an IP30 cover carrying a warning label 'Do not open when energised'.

Appendix 2 IECEx certification

A2.0 The IECEx Certification Scheme

IECEx is a global certification scheme for explosion protected products which aims to harmonise international certification standards. For additional information about the IECEx certification scheme and to view the BEKA associate certificates, please visit www.iecex.com

A2.1 IECEx Certificate of Conformity

The BA367E-SS Counter has been issued with an IECEx Certificate of Conformity number IECEx ITS 16.0004X which specifies the following certification code:

Ex ia IIC T5 Ga
Ex ia IIIC T 80°C Da
-40°C ≤ Ta ≤ +60°C

When installed as purely intrinsically safe apparatus i.e. when not relying upon the ingress and impact resistance of the Counter front in an Ex e, Ex p, Ex n or Ex t panel enclosure the ambient temperature range is increased to $-40^{\circ}\text{C} \leq T_a \leq +70^{\circ}\text{C}$

The IECEx certificate may be downloaded from www.beka.co.uk, www.iecex.com or requested from the BEKA sales office.

A2.2 Installation

The IECEx intrinsic safety parameters are identical to the ATEX safety parameters described in the main section of this manual and both refer to the same standards. Therefore the ATEX installation requirements specified in section 5 and Appendix 1 of this manual may be used for IECEx installations, but the local code of practice should also be consulted.

A2.3 Special conditions for safe use

The IECEx intrinsic safety certificate number has an 'X' suffix indicating that for some applications special conditions apply for safe use.

- For use in group III explosive dust atmospheres the BA367E-SS shall be mounted such that the rear of the instrument has at least IP54 protection.
- For use in group IIIC conductive explosive dust atmospheres the BA367E-SS shall be mounted such that the rear terminals have at least IP6X protection.

This means that when installed in an Ex e, Ex n, Ex p or Ex t panel enclosure the BA367E-SS remains an intrinsically safe instrument and must comply with the installation requirements shown in this manual.

The certificate also states:

The front of the stainless steel enclosure complies with the requirements for Ex e, Ex n Ex p & Ex t type of protection.

Therefore when correctly installed in a certified panel enclosure the BA367E-SS Counter will not invalidate the Ex e, Ex n, Ex p or Ex t panel enclosure certification.

Appendix 3 ETL & cETL certification for installations in USA and Canada

A3.0 cETL Mark

For installations in the USA and Canada, the BA367E-SS rugged Counter has ETL and cETL intrinsic safety and nonincendive approval, Control Number 4008610. Copies of the Authorisation to Mark are available from the BEKA associates sales office and www.beka.co.uk

A3.1 Intrinsic safety approval

The US and Canadian standards used for assessment and certification of the BA367E-SS are listed on the cETL Authorisation to Mark.

Installations must comply with BEKA associates Control Drawing CI330-52, which is attached to this appendix.

The ETL and cETL safety parameters are the same as the ATEX and IECEx parameters, the systems shown in sections 3 and 4 of this manual may therefore also be used for US and Canadian installations subject to compliance with local codes of practice.

ETL and cETL intrinsic safety codes

CL I Div 1 Groups A, B, C, D T5 (US IS gas, Div cert)
CL II Div 1 Groups E, F, G. CL III (US IS dust, Div cert)

Class I Zone 0 AEx ia IIC T5 Ga (US IS gas, Zone cert)
Zone 20 AEx ia IIIC T80°C Da (US IS dust, Zone cert)

Ex ia IIC T5 Ga (Canadian IS gas, Zone cert)
Ex ia IIIC T80°C Da (Canadian IS dust, Zone cert)

$-40^{\circ}\text{C} \leq T_a \leq 60^{\circ}\text{C}$

A3.2 Nonincendive approval

The BA367E-SS rugged Counter also has ETL and cETL nonincendive approval allowing installation in Division 2 hazardous (classified) locations without the need for Zener barriers or galvanic isolators.

Installations must comply with BEKA associates Control Drawing CI330-53, which is attached to this appendix and the local codes of practice.

ETL and cETL nonincendive codes US & Canada

CL I Div 2 Groups A, B, C, D T5
CL II Div 2 Groups F, G CL III Div 2
 $-40^{\circ}\text{C} \leq T_a \leq 70^{\circ}\text{C}$

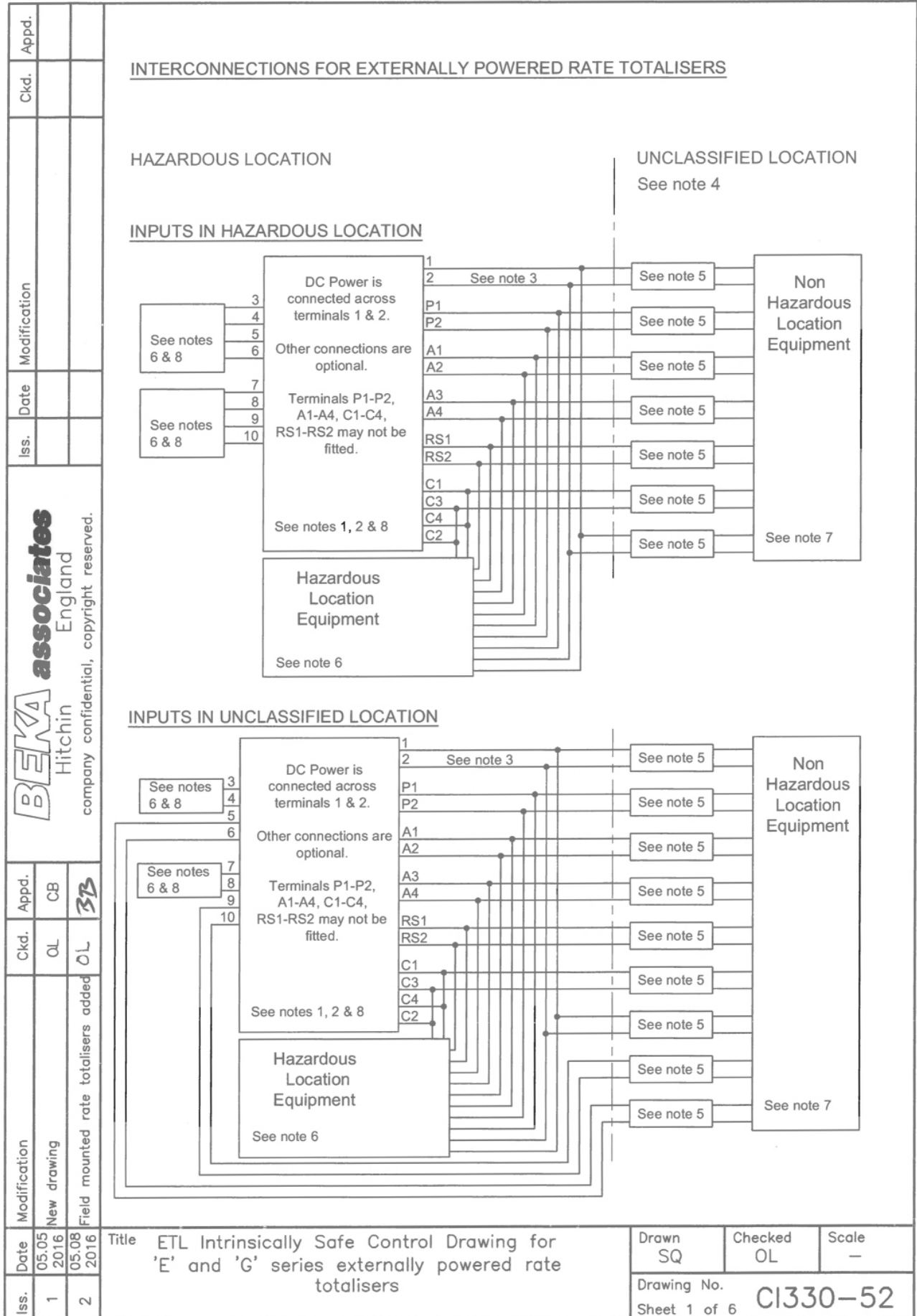

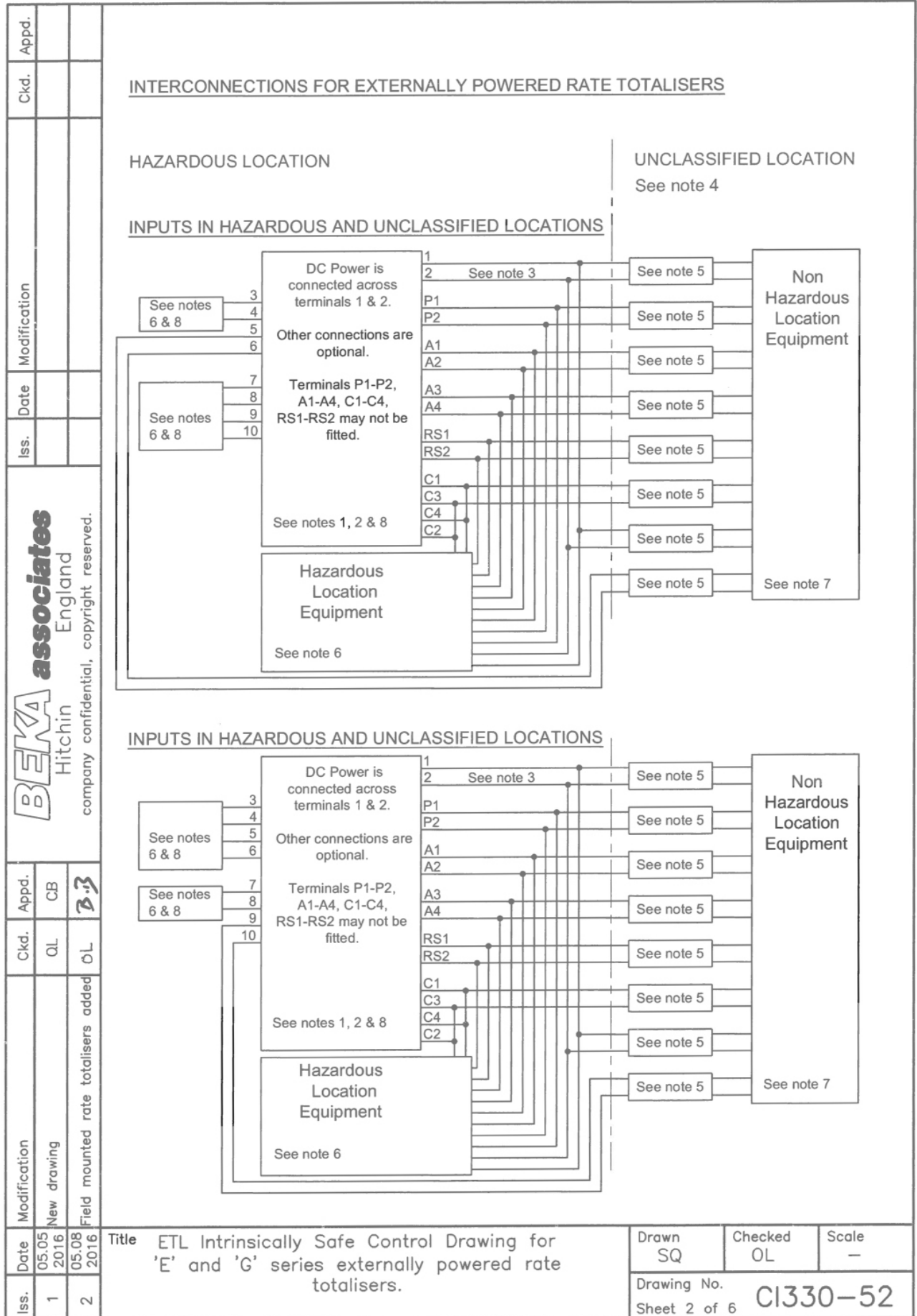

Title ETL Intrinsically Safe Control Drawing for 'E' and 'G' series externally powered rate totalisers.

Drawn
SQ

Checked
OL

Scale
-

Drawing No.
Sheet 2 of 6

CI330-52

Iss.		Date		Modification		Ckd.		Appd.		<p>3. Installations shall be in accordance with ANSI/ISA RP 12.06.01 'Installation of Intrinsically Safe Systems for Hazardous (Classified) Locations' and the National Electrical Code ANSI/NFPA 70. Installations in Canada shall be in accordance with the Canadian Electrical Code C22.2.</p> <p>4. The associated protective barriers and galvanic isolators shall be NRTL approved and the manufacturers instructions shall be followed when installing this equipment. For installations in Canada the associated protective barriers and galvanic isolators shall be NRTL or CSA approved and the manufacturers installation drawings shall be followed when installing this equipment.</p> <p>5. One single channel or one two channel associated protective barrier or galvanic isolator with entity parameters complying with the following requirements:</p> <p>Uo equal or less than the lowest Ui of the NRTL or CSA approved apparatus installed in the loop.</p> <p>Io equal or less than the lowest li of the NRTL or CSA approved apparatus installed in the loop.</p> <p>Po equal or less than the lowest Pi of the NRTL or CSA approved apparatus installed in the loop.</p> <p>Lo equal or greater than the sum of the cable inductances and the internal inductances Li of each NRTL or CSA approved apparatus in the loop.</p> <p>Co equal or greater than the sum of the cable capacitance and the internal capacitance Ci of each NRTL or CSA approved apparatus in the loop.</p> <p>6. Simple Apparatus as defined in the National Electrical Code ANSI/NFPA 70, or for installations in Canada by the Canadian Electrical Code C22.2 OR:</p> <p>Ui equal or greater than the highest Uo of the NRTL or CSA approved apparatus powering the loop.</p> <p>li equal or greater than the highest lo of the NRTL or CSA approved apparatus powering the loop.</p> <p>Pi equal or greater than the highest Po of the NRTL or CSA approved apparatus powering the loop.</p> <p>Lo of the NRTL or CSA approved apparatus powering the loop equal or greater than the sum of the cable inductances and the internal inductances Li of each NRTL or CSA approved apparatus in the loop.</p> <p>Co of the NRTL or CSA approved apparatus powering the loop equal or greater than the sum of the cable capacitances and the internal capacitances Ci of each NRTL or CSA approved apparatus in the loop.</p>	
Iss.		Date		Modification		Ckd.		Appd.			
1		05.05 2016		New drawing		OL		CB			
2		05.08 2016		Field mounted rate totalisers added		OL		BB			
Title		ETL Intrinsically Safe Control Drawing for 'E' and 'G' series externally powered rate totalisers.				Drawn SQ		Checked OL		Scale -	
						Drawing No.		CI330-52			
						Sheet 4 of 6					

Iss.		Date		Modification		Ckd.		Appd.											
1		05.05.2016		New drawing															
2		05.08.2016		Field mounted rate totalisers added		OL		DL											
<div style="display: flex; justify-content: space-between;"> <div style="width: 20%;"> <p>BEKA associates Hitchin England company confidential, copyright reserved.</p> </div> <div style="width: 80%; text-align: center;"> <p>3.3</p> </div> </div>																			
										Iss.		Date		Modification		Ckd.		Appd.	
<p>7. The unclassified location equipment shall not use or generate more than 250V rms or 250V dc.</p>																			
<p>8. Safety parameters</p> <table border="0" style="width: 100%;"> <tr> <td style="width: 50%; vertical-align: top;"> <p>DC Power terminals 1 & 2</p> <p> $U_i = 28V$ $U_o = 0$ $I_i = 200mA$ $I_o = 0$ $P_i = 0.84W$ $C_i = 2nF$ $L_i = 4\mu H$ </p> <p>Terminals 4,5,6 (input A for models in notes 6 and 7), terminals 8,9,10 (input b for models in note 7).</p> <p> $U_i = 28V$ $U_o = 1.1V$ $I_i = 200mA$ $I_o = 0.5mA$ $P_i = 0.84W$ $P_o = 0.2mW$ $C_i = 2nF$ $L_i = 4\mu H$ </p> <p>Optional pulse output terminals P1 & P2</p> <p> $U_i = 28V$ $U_o = 0$ $I_i = 200mA$ $I_o = 0$ $P_i = 0.84W$ $C_i = 0$ $L_i = 0$ </p> <p>Optional alarm output terminals A1, A2, A3 and A4</p> <p> $U_i = 28V$ $U_o = 1.47V$ $I_i = 200mA$ $I_o = 1\mu A$ $P_i = 0.84W$ $P_o = 2\mu W$ $C_i = 22nF$ $L_i = 4\mu H$ </p> </td> <td style="width: 50%; vertical-align: top;"> <p>Terminals RS1-RS2, (optional reset input)</p> <p> $U_i = 28V$ $U_o = 3.8V$ $I_i = 200mA$ $I_o = 1mA$ $P_i = 0.84W$ $P_o = 1mW$ $C_i = 0$ $L_i = 0$ </p> <p>Terminal 3,4,5,6 (input A for models in notes 6 and 7), terminals 7,8,9,10 (input b for models in note 7).</p> <p> $U_i = 14V$ $U_o = 10.5V$ $I_i = 200mA$ $I_o = 9.2mA$ $P_i = 0.7W$ $P_o = 24mW$ $C_i = 2nF$ $L_i = 4\mu H$ </p> <p>Optional 4-20mA output terminals C1, C2, C3 and C4</p> <p> $U_i = 28V$ $U_o = 0$ $I_i = 200mA$ $I_o = 0$ $P_i = 0.84W$ $C_i = 2.2nF$ $L_i = 4\mu H$ </p> </td> </tr> </table>										<p>DC Power terminals 1 & 2</p> <p> $U_i = 28V$ $U_o = 0$ $I_i = 200mA$ $I_o = 0$ $P_i = 0.84W$ $C_i = 2nF$ $L_i = 4\mu H$ </p> <p>Terminals 4,5,6 (input A for models in notes 6 and 7), terminals 8,9,10 (input b for models in note 7).</p> <p> $U_i = 28V$ $U_o = 1.1V$ $I_i = 200mA$ $I_o = 0.5mA$ $P_i = 0.84W$ $P_o = 0.2mW$ $C_i = 2nF$ $L_i = 4\mu H$ </p> <p>Optional pulse output terminals P1 & P2</p> <p> $U_i = 28V$ $U_o = 0$ $I_i = 200mA$ $I_o = 0$ $P_i = 0.84W$ $C_i = 0$ $L_i = 0$ </p> <p>Optional alarm output terminals A1, A2, A3 and A4</p> <p> $U_i = 28V$ $U_o = 1.47V$ $I_i = 200mA$ $I_o = 1\mu A$ $P_i = 0.84W$ $P_o = 2\mu W$ $C_i = 22nF$ $L_i = 4\mu H$ </p>	<p>Terminals RS1-RS2, (optional reset input)</p> <p> $U_i = 28V$ $U_o = 3.8V$ $I_i = 200mA$ $I_o = 1mA$ $P_i = 0.84W$ $P_o = 1mW$ $C_i = 0$ $L_i = 0$ </p> <p>Terminal 3,4,5,6 (input A for models in notes 6 and 7), terminals 7,8,9,10 (input b for models in note 7).</p> <p> $U_i = 14V$ $U_o = 10.5V$ $I_i = 200mA$ $I_o = 9.2mA$ $P_i = 0.7W$ $P_o = 24mW$ $C_i = 2nF$ $L_i = 4\mu H$ </p> <p>Optional 4-20mA output terminals C1, C2, C3 and C4</p> <p> $U_i = 28V$ $U_o = 0$ $I_i = 200mA$ $I_o = 0$ $P_i = 0.84W$ $C_i = 2.2nF$ $L_i = 4\mu H$ </p>								
<p>DC Power terminals 1 & 2</p> <p> $U_i = 28V$ $U_o = 0$ $I_i = 200mA$ $I_o = 0$ $P_i = 0.84W$ $C_i = 2nF$ $L_i = 4\mu H$ </p> <p>Terminals 4,5,6 (input A for models in notes 6 and 7), terminals 8,9,10 (input b for models in note 7).</p> <p> $U_i = 28V$ $U_o = 1.1V$ $I_i = 200mA$ $I_o = 0.5mA$ $P_i = 0.84W$ $P_o = 0.2mW$ $C_i = 2nF$ $L_i = 4\mu H$ </p> <p>Optional pulse output terminals P1 & P2</p> <p> $U_i = 28V$ $U_o = 0$ $I_i = 200mA$ $I_o = 0$ $P_i = 0.84W$ $C_i = 0$ $L_i = 0$ </p> <p>Optional alarm output terminals A1, A2, A3 and A4</p> <p> $U_i = 28V$ $U_o = 1.47V$ $I_i = 200mA$ $I_o = 1\mu A$ $P_i = 0.84W$ $P_o = 2\mu W$ $C_i = 22nF$ $L_i = 4\mu H$ </p>	<p>Terminals RS1-RS2, (optional reset input)</p> <p> $U_i = 28V$ $U_o = 3.8V$ $I_i = 200mA$ $I_o = 1mA$ $P_i = 0.84W$ $P_o = 1mW$ $C_i = 0$ $L_i = 0$ </p> <p>Terminal 3,4,5,6 (input A for models in notes 6 and 7), terminals 7,8,9,10 (input b for models in note 7).</p> <p> $U_i = 14V$ $U_o = 10.5V$ $I_i = 200mA$ $I_o = 9.2mA$ $P_i = 0.7W$ $P_o = 24mW$ $C_i = 2nF$ $L_i = 4\mu H$ </p> <p>Optional 4-20mA output terminals C1, C2, C3 and C4</p> <p> $U_i = 28V$ $U_o = 0$ $I_i = 200mA$ $I_o = 0$ $P_i = 0.84W$ $C_i = 2.2nF$ $L_i = 4\mu H$ </p>																		
<p>9. When installed purely as intrinsically safe equipment in division 1, division 2, zone 0, zone 1 or zone 2, the ambient temperature range of the BA317E-SS, BA337E-SS, BA367E-SS, BA377E-SS, BA314G, BA334G, BA364G, BA374G and BA384G is: $-40^{\circ}C \leq T_a \leq +70^{\circ}C$.</p>																			
Title						Drawn		Checked		Scale									
ETL Intrinsically Safe Control Drawing for 'E' and 'G' series externally powered rate totalisers.						SQ		OL		-									
						Drawing No. CI330-52													
						Sheet 5 of 6													

Iss.	Date	Modification	Ckd.	Appd.	Iss.	Date	Modification	Ckd.	Appd.	<p>10. CAUTION Aluminium and stainless steel certification labels that are mounted on the BA317E, BA318E, BA337E, BA338E, BA367E, BA368E, BA377E, BA378E and BA388E externally powered rate totaliser enclosures may be marked with their maximum capacitance (8pF). The BA317E, BA318E, BA337E, BA338E, BA367E, BA368E, BA377E, BA378E and BA388E enclosures may also carry the following potential electrostatic warning:</p> <p style="text-align: center;">WARNING</p> <p style="text-align: center;">Potential electrostatic charging hazard clean only with a damp cloth</p> <p style="text-align: center;">AVERTISSEMENT</p> <p style="text-align: center;">Risque potentiel de charge électrostatique Nettoyer uniquement avec un chiffon humide</p> <p>Alternatively, the enclosures may be manufactured from a conducting plastic per Article 250 of the National Electrical Code.</p>
1	05.05 2016	New drawing	QL	CB	1					<p>12. When mounting the BA317E-SS, BA337E-SS, BA367E-SS, and BA377E-SS panel mounting externally powered rate totalisers in an AEx e, AEx n, AEx p or AEx t certified enclosure, or an enclosure to maintain IP66 front panel rating, the panel cut-out shall be:</p> <p style="margin-left: 40px;">92.0 +0.8/-0.0 x 45.0 +0.6/-0.0mm (3.62 +0.03/-0.0 x 1.77 +0.02/-0.0 inches)</p> <p style="margin-left: 40px;">4 panel mounting clamps are required and each shall be tightened to a minimum of 22cNm (1.95inLb).</p> <p style="margin-left: 40px;">When correctly installed, the BA317E-SS, BA337E-SS, BA367E-SS and BA377E-SS will not invalidate the certification of an AEx e, AEx n, AEx p or AEx t panel enclosure.</p>
2	05.08 2016	Field mounted rate totalisers added	OL	3.3						
Title					ETL Intrinsically Safe Control Drawing for 'E' and 'G' series externally powered rate totalisers.			Drawn	Checked	Scale
								SQ	OL	-
								Drawing No. C1330-52		
								Sheet 6 of 6		

Iss.	1	Date	15.06.2016	Appd.	CB	Modification	New drawing	Ckd.	QL
Iss.	2	Date	05.08.2016	Appd.	33	Modification	Field mounted rate totalisers added	Ckd.	OL

BEKA associates
Hitchin
England
company confidential, copyright reserved.

INTERCONNECTIONS FOR EXTERNALLY POWERED RATE TOTALISERS

HAZARDOUS LOCATION

UNCLASSIFIED LOCATION
See note 4

INPUTS IN HAZARDOUS LOCATION

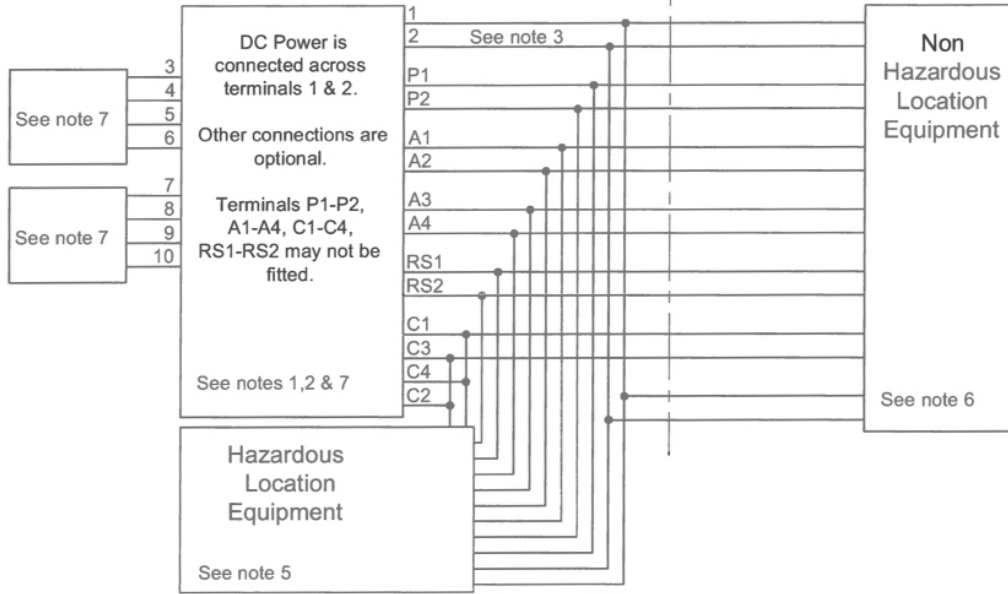

INPUTS IN UNCLASSIFIED LOCATION

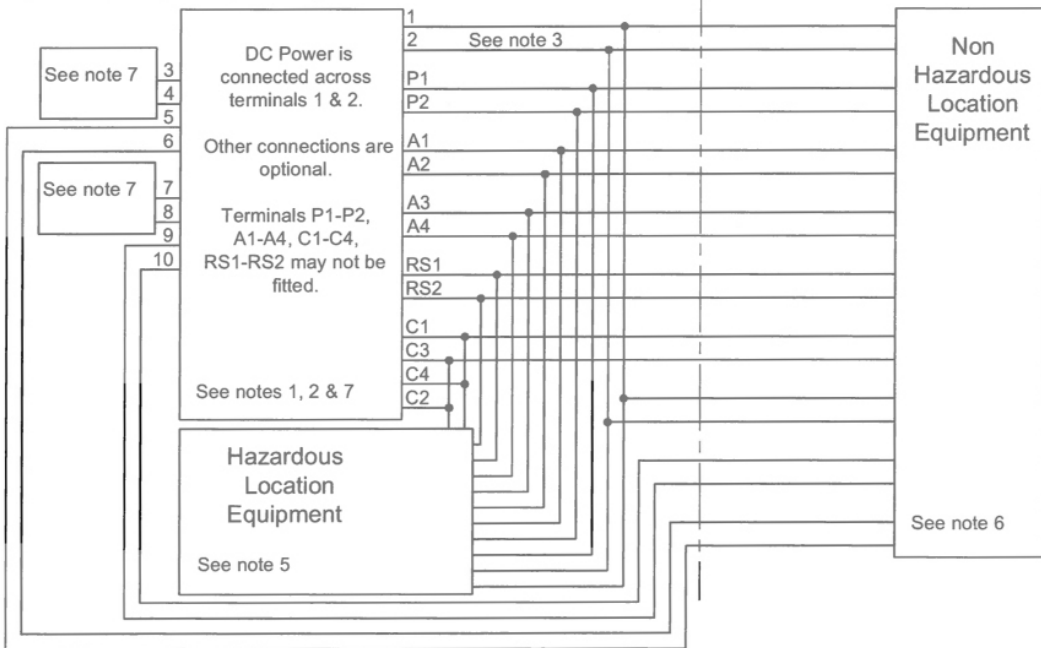

Title
ETL Nonincendive
Control Drawing for 'E' and 'G' series
externally powered rate totalisers.

Drawn SQ
Checked OL
Scale -

Drawing No. **CI330-53**
Sheet 1 of 6

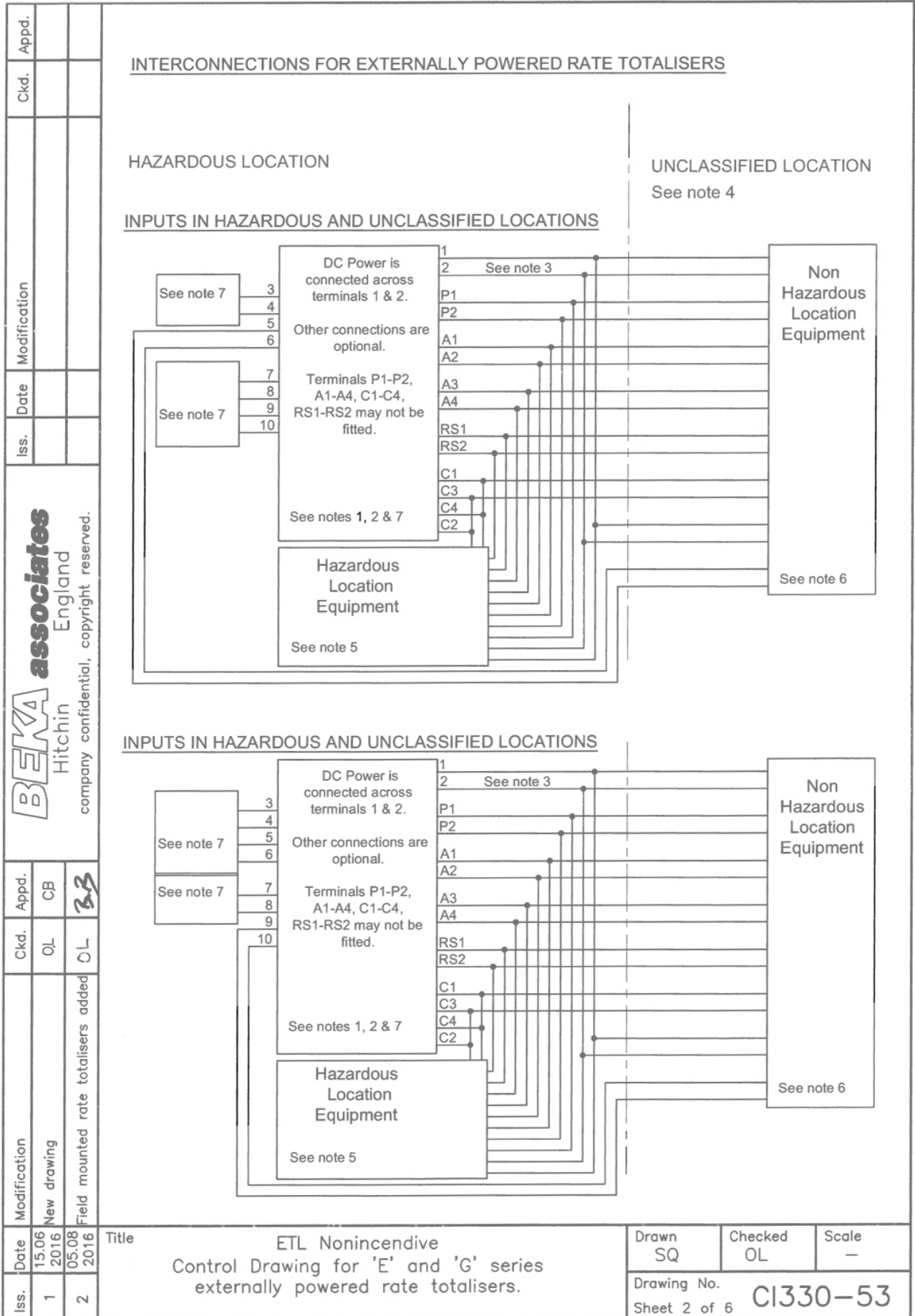



Iss.		Date		Modification		Ckd.		Appd.	
1		15.06.2016		New drawing		OL		CB	
2		05.08.2016		Field mounted rate totalisers added		OL		B3	

BEKA associates
Hitchin
England
company confidential, copyright reserved.

Title
ETL Nonincendive Control Drawing for 'E' and 'G' series externally powered rate totalisers.

Drawn SQ	Checked OL	Scale -
Drawing No. CI330-53		
Sheet 2 of 6		

Iss.	1	Date	05.05 2016	Modification	New drawing	Ckd.	QL	Appd.	CB																																																												
	2		05.08 2016		Field mounted rate totalisers added		OL		3.3																																																												
																																																																					
<p>Notes</p> <p>1. 1 and 2 input externally powered rate totalisers with model numbers and coding as shown in the following tables.</p> <p style="text-align: center;">NE PANEL MOUNTING INSTRUMENTS</p> <table border="1" style="width: 100%; border-collapse: collapse;"> <thead> <tr> <th style="width: 15%;">Type</th> <th style="width: 15%;">Model Nos.</th> <th style="width: 30%;">Division Marking</th> <th style="width: 15%;">Zonal Marking (see note B)</th> <th style="width: 25%;">Ambient Temp. (see note 9)</th> </tr> </thead> <tbody> <tr> <td>1 input tachometer 1 input rate totaliser 1 input counter 1 input timer</td> <td>BA317NE BA337NE BA367NE BA377NE</td> <td>Class I Division 2 Groups A, B, C & D T5 Class II Division 2 Groups F & G Class III Division 2</td> <td>Zone 2 AEx nA ic IIC T5 Gc Zone 22 AEx ic tc IIIC T80°C Dc</td> <td>-40°C to +60°C</td> </tr> </tbody> </table> <p style="text-align: center;">E PANEL MOUNTING INSTRUMENTS</p> <table border="1" style="width: 100%; border-collapse: collapse;"> <thead> <tr> <th style="width: 15%;">Type</th> <th style="width: 15%;">Model Nos.</th> <th style="width: 30%;">Division Marking</th> <th style="width: 15%;">Zonal Marking</th> <th style="width: 25%;">Ambient Temp.</th> </tr> </thead> <tbody> <tr> <td>1 input tachometer 1 input rate totaliser 2 input rate totaliser 1 input counter 2 input counter 1 input timer 2 input timer</td> <td>BA317E BA318E BA337E BA338E BA388E BA367E BA368E BA377E BA378E</td> <td>Class I Division 2 Groups A, B, C & D T5 Class II Division 2 Groups F & G Class III Division 2</td> <td>None</td> <td>-40°C to +70°C</td> </tr> </tbody> </table> <p style="text-align: center;">E-SS PANEL MOUNTING INSTRUMENTS</p> <table border="1" style="width: 100%; border-collapse: collapse;"> <thead> <tr> <th style="width: 15%;">Type</th> <th style="width: 15%;">Model Nos.</th> <th style="width: 30%;">Division Marking</th> <th style="width: 15%;">Zonal Marking</th> <th style="width: 25%;">Ambient Temp.</th> </tr> </thead> <tbody> <tr> <td>1 input tachometer 1 input rate totaliser 1 input counter 1 input timer</td> <td>BA317E-SS BA337E-SS BA367E-SS BA377E-SS</td> <td>Class I Division 2 Groups A, B, C & D T5 Class II Division 2 Groups F & G Class III Division 2</td> <td>None</td> <td>-40°C to +70°C</td> </tr> </tbody> </table> <p style="text-align: center;">NG FIELD MOUNTING INSTRUMENTS</p> <table border="1" style="width: 100%; border-collapse: collapse;"> <thead> <tr> <th style="width: 15%;">Type</th> <th style="width: 15%;">Model Nos.</th> <th style="width: 30%;">Division Marking</th> <th style="width: 15%;">Zonal Marking (see note B)</th> <th style="width: 25%;">Ambient Temp. (see note 9)</th> </tr> </thead> <tbody> <tr> <td>1 input tachometer 1 input rate totaliser 2 input rate totaliser 2 input counter 2 input timer</td> <td>BA314NG BA334NG BA384NG BA364NG BA374NG</td> <td>Class I Division 2 Groups A, B, C & D T5 Class II Division 2 Groups F & G Class III Division 2</td> <td>Zone 2 AEx nA ic IIC T5 Gc Zone 22 AEx ic tc IIIC T80°C Dc</td> <td>-40°C to +60°C</td> </tr> </tbody> </table> <p style="text-align: center;">G FIELD MOUNTING INSTRUMENTS</p> <table border="1" style="width: 100%; border-collapse: collapse;"> <thead> <tr> <th style="width: 15%;">Type</th> <th style="width: 15%;">Model Nos.</th> <th style="width: 30%;">Division Marking</th> <th style="width: 15%;">Zonal Marking</th> <th style="width: 25%;">Ambient Temp.</th> </tr> </thead> <tbody> <tr> <td>1 input tachometer 1 input rate totaliser 2 input rate totaliser 2 input counter 2 input timer</td> <td>BA314G BA334G BA384G BA364G BA374G</td> <td>Class I Division 2 Groups A, B, C & D T5 Class II Division 2 Groups F & G Class III Division 2</td> <td>None</td> <td>-40°C to +70°C</td> </tr> </tbody> </table> <p style="text-align: center;">E FIELD MOUNTING INSTRUMENTS</p> <table border="1" style="width: 100%; border-collapse: collapse;"> <thead> <tr> <th style="width: 15%;">Type</th> <th style="width: 15%;">Model Nos.</th> <th style="width: 30%;">Division Marking</th> <th style="width: 15%;">Zonal Marking</th> <th style="width: 25%;">Ambient Temp.</th> </tr> </thead> <tbody> <tr> <td>1 input tachometer 1 input rate totaliser 2 input rate totaliser 2 input counter 2 input timer</td> <td>BA314E BA334E BA384E BA364E BA374E</td> <td>Class I Division 2 Groups A, B, C & D T5 Class II Division 2 Groups F & G Class III Division 2</td> <td>None</td> <td>-40°C to +70°C</td> </tr> </tbody> </table>										Type	Model Nos.	Division Marking	Zonal Marking (see note B)	Ambient Temp. (see note 9)	1 input tachometer 1 input rate totaliser 1 input counter 1 input timer	BA317NE BA337NE BA367NE BA377NE	Class I Division 2 Groups A, B, C & D T5 Class II Division 2 Groups F & G Class III Division 2	Zone 2 AEx nA ic IIC T5 Gc Zone 22 AEx ic tc IIIC T80°C Dc	-40°C to +60°C	Type	Model Nos.	Division Marking	Zonal Marking	Ambient Temp.	1 input tachometer 1 input rate totaliser 2 input rate totaliser 1 input counter 2 input counter 1 input timer 2 input timer	BA317E BA318E BA337E BA338E BA388E BA367E BA368E BA377E BA378E	Class I Division 2 Groups A, B, C & D T5 Class II Division 2 Groups F & G Class III Division 2	None	-40°C to +70°C	Type	Model Nos.	Division Marking	Zonal Marking	Ambient Temp.	1 input tachometer 1 input rate totaliser 1 input counter 1 input timer	BA317E-SS BA337E-SS BA367E-SS BA377E-SS	Class I Division 2 Groups A, B, C & D T5 Class II Division 2 Groups F & G Class III Division 2	None	-40°C to +70°C	Type	Model Nos.	Division Marking	Zonal Marking (see note B)	Ambient Temp. (see note 9)	1 input tachometer 1 input rate totaliser 2 input rate totaliser 2 input counter 2 input timer	BA314NG BA334NG BA384NG BA364NG BA374NG	Class I Division 2 Groups A, B, C & D T5 Class II Division 2 Groups F & G Class III Division 2	Zone 2 AEx nA ic IIC T5 Gc Zone 22 AEx ic tc IIIC T80°C Dc	-40°C to +60°C	Type	Model Nos.	Division Marking	Zonal Marking	Ambient Temp.	1 input tachometer 1 input rate totaliser 2 input rate totaliser 2 input counter 2 input timer	BA314G BA334G BA384G BA364G BA374G	Class I Division 2 Groups A, B, C & D T5 Class II Division 2 Groups F & G Class III Division 2	None	-40°C to +70°C	Type	Model Nos.	Division Marking	Zonal Marking	Ambient Temp.	1 input tachometer 1 input rate totaliser 2 input rate totaliser 2 input counter 2 input timer	BA314E BA334E BA384E BA364E BA374E	Class I Division 2 Groups A, B, C & D T5 Class II Division 2 Groups F & G Class III Division 2	None	-40°C to +70°C
Type	Model Nos.	Division Marking	Zonal Marking (see note B)	Ambient Temp. (see note 9)																																																																	
1 input tachometer 1 input rate totaliser 1 input counter 1 input timer	BA317NE BA337NE BA367NE BA377NE	Class I Division 2 Groups A, B, C & D T5 Class II Division 2 Groups F & G Class III Division 2	Zone 2 AEx nA ic IIC T5 Gc Zone 22 AEx ic tc IIIC T80°C Dc	-40°C to +60°C																																																																	
Type	Model Nos.	Division Marking	Zonal Marking	Ambient Temp.																																																																	
1 input tachometer 1 input rate totaliser 2 input rate totaliser 1 input counter 2 input counter 1 input timer 2 input timer	BA317E BA318E BA337E BA338E BA388E BA367E BA368E BA377E BA378E	Class I Division 2 Groups A, B, C & D T5 Class II Division 2 Groups F & G Class III Division 2	None	-40°C to +70°C																																																																	
Type	Model Nos.	Division Marking	Zonal Marking	Ambient Temp.																																																																	
1 input tachometer 1 input rate totaliser 1 input counter 1 input timer	BA317E-SS BA337E-SS BA367E-SS BA377E-SS	Class I Division 2 Groups A, B, C & D T5 Class II Division 2 Groups F & G Class III Division 2	None	-40°C to +70°C																																																																	
Type	Model Nos.	Division Marking	Zonal Marking (see note B)	Ambient Temp. (see note 9)																																																																	
1 input tachometer 1 input rate totaliser 2 input rate totaliser 2 input counter 2 input timer	BA314NG BA334NG BA384NG BA364NG BA374NG	Class I Division 2 Groups A, B, C & D T5 Class II Division 2 Groups F & G Class III Division 2	Zone 2 AEx nA ic IIC T5 Gc Zone 22 AEx ic tc IIIC T80°C Dc	-40°C to +60°C																																																																	
Type	Model Nos.	Division Marking	Zonal Marking	Ambient Temp.																																																																	
1 input tachometer 1 input rate totaliser 2 input rate totaliser 2 input counter 2 input timer	BA314G BA334G BA384G BA364G BA374G	Class I Division 2 Groups A, B, C & D T5 Class II Division 2 Groups F & G Class III Division 2	None	-40°C to +70°C																																																																	
Type	Model Nos.	Division Marking	Zonal Marking	Ambient Temp.																																																																	
1 input tachometer 1 input rate totaliser 2 input rate totaliser 2 input counter 2 input timer	BA314E BA334E BA384E BA364E BA374E	Class I Division 2 Groups A, B, C & D T5 Class II Division 2 Groups F & G Class III Division 2	None	-40°C to +70°C																																																																	
<p>Title</p> <p>ETL Nonincendive Control Drawing for 'E' and 'G' series externally powered rate totalisers.</p>						<p>Drawn SQ</p>	<p>Checked OL</p>	<p>Scale -</p>																																																													
<p>Drawing No.</p> <p>Sheet 3 of 6</p>						<p>C1330-53</p>																																																															

Iss.		Date		Modification		Ckd.		Appd.		
1		15.06 2016		New drawing		QL		CB		
2		05.08 2016		Field mounted rate totalisers added		OL		Z.B		
										
<p>2. Terminals 7, 8, 9 and 10 only exist on 2 input instruments.</p> <p>3. Nonincendive field wiring installations shall be in accordance with the National Electrical Code ANSI/NFPA 70. The Nonincendive Field Wiring concept allows interconnection of Nonincendive Field Apparatus with Associated Nonincendive Field Wiring Apparatus using any of the wiring methods permitted for unclassified locations. Installations in Canada shall be in accordance with the Canadian Electrical Code C22.2.</p> <p>4. Classified location equipment shall be NRTL Approved Nonincendive Field Wiring Apparatus or simple apparatus as defined in ANSI/NFPA70. For Canadian installations classified location equipment shall be NRTL or CSA Approved Nonincendive Field Wiring Apparatus.</p> <p>5. Simple Apparatus as defined in the National Electrical Code ANSI/NFPA 70, 3r for installations in Canada by the Canadian Electrical Code C22.2 or as defined in note 2.</p> <p>6. The unclassified location equipment shall not use or generate more than 250V rms or 250V dc.</p>										
Title				ETL Nonincendive Control Drawing for 'E' and 'G' series externally powered rate totalisers.			Drawn SQ		Checked OL	
							Scale -			
							Drawing No. Sheet 4 of 6		C1330-53	

Iss.	Date	Modification	Ckd.	Appd.	<p>BEKA associates Hitchin England company confidential, copyright reserved.</p>	<p>7. Safety parameters</p> <p>DC Power terminals 1 & 2</p> <p>$U_i = 30V$ $I_i = 100mA$</p> <p>Terminals 4,5,6 (input A for models in notes 5 and 6), terminals 8,9,10 (input b for models in note 6).</p> <p>$U_i = 30V$ $U_o = 1.1V$ $I_o = 0.5mA$</p> <p>Optional pulse output terminals P1 & P2</p> <p>$U_i = 30V$ $I_i = 100mA$ $U_o = 0$ $I_o = 0$</p> <p>Optional alarm output terminals A1, A2, A3 and A4</p> <p>$U_i = 30V$ $I_i = 200mA$ $U_o = 1.47V$ $I_o = 1\mu A$</p> <p>8. The 'AEx ic' in codes refers to instrument push button contacts which are nonincendive.</p> <p>9. When installed purely as non-incendive equipment, the ambient temperature range of the BA317NE, BA337NE, BA367NE, BA377NE, BA314NG, BA334NG, BA364NG, BA374NG, and BA384NG is: $-40^{\circ}C \leq T_a \leq +70^{\circ}C$.</p>		
1	15.06.2016	New drawing	OL	CB				
2	05.08.2016	Field mounted rate totalisers added	OL	AB				
Iss.	1	2	Title		<p>ETL Nonincendive Control Drawing for 'E' and 'G' series externally powered rate totalisers.</p>			
Date		15.06.2016	Drawn	SQ	Checked	OL	Scale	-
Iss.		1	Drawing No.		C1330-53		Sheet 5 of 6	

Iss.	Date	Modification	Ckd.	Appd.	Iss.	Date	Modification	Ckd.	Appd.	<p>10. CAUTION The BA317E, BA318E, BA337E, BA338E, BA367E, BA368E, BA377E, BA378E and the BA388E Externally Powered rate totaliser enclosures may carry the following potential electrostatic warning:</p> <p style="text-align: center;">WARNING</p> <p style="text-align: center;">Potential electrostatic charging hazard clean only with a damp cloth</p> <p style="text-align: center;">AVERTISSEMENT</p> <p style="text-align: center;">Risque potentiel de charge électrostatique Nettoyer uniquement avec un chiffon humide</p> <p>Alternatively, the enclosures may be manufactured from a conducting plastic per Article 250 of the National Electrical Code.</p>
1	15.06 2016	New drawing	OL	CB	1					
2	05.08 2016	Field mounted rate totalisers added	OL	B.B						
Title					<p style="text-align: center;">ETL Nonincendive Control Drawing for 'E' and 'G' series externally powered rate totalisers.</p>					
Date					Drawn	Checked	Scale			
15.06 2016					SQ	OL	-			
Iss.					Drawing No.					
1					Sheet 6 of 6			CI330-53		