

# Ball Brothers Glass Mfg. Co.

Bill Lockhart, Beau Schriever, Carol Serr, and Bill Lindsey

with contributions by Jim Sears

It was only by chance that two brothers named Ball, manufacturers of cans at Buffalo, New York, happened into the glass business. They soon brought their other three brothers into the business, moved to Muncie, Indiana, and became one of the largest producers of fruit jars in the U.S. They expanded their business, adopting semiautomatic and fully automatic machinery, engulfed competitor after competitor, and saw the term “Ball jar” become synonymous with “fruit jar.”

## History

### Ball Brothers, Buffalo, New York (1884-1888)

Frank Clayton Ball and Edmund Burke Ball borrowed \$200 from their uncle, the Rev. George H. Ball, a Baptist preacher. Under the firm name of the Wood Jacket Can Co., they began manufacturing wood-jacketed cans at Buffalo, New York, in 1880. According to Frank Ball, these were tin cans with wooden jackets, from one to ten gallons in size (Figure 1). These were sold for shipping paints and oils. The firm eventually became the Ball Bros. (Ball 1937:52; Roller 1983:451-453).<sup>1</sup>

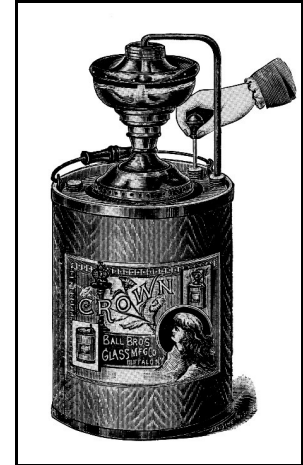

Figure 1 – Ball Brothers can (Bingham 1980:61)

The Balls began making glass inserts for the cans ca. 1884. As Toulouse (1969:358) told the story, “Chance brought some itinerant glass blowers to Buffalo. Ball hired them, built a small furnace in 1885, and went into the glass business.” Roller (2010:654) added that the Balls had been buying glass

---

<sup>1</sup> City directories for the period show the Ball Brothers making tin cans and general tinware. The brothers were not listed under glassware until 1886 (Roller 1997).

from the Poughkeepsie Glass Works, so making their own must have seemed like a good idea. The first Mason jars were apparently produced to use up surplus glass.

In slight contrast, Frank Ball told a different story: William Bryan and some other blowers moved from Poughkeepsie to Olean, New York, to start a cooperative plant, and the Balls purchased glass inserts from them and covered those with tin jackets. When a fire destroyed the Olean plant, Bryan “came to us and proposed to build a glass factory for us.” According to Ball, the glass plant opened in 1882 as a separate operation from the can factory (Ball 1937:59-60).<sup>2</sup>

In May 1885, production had reached the point where some workers began making “MASON IMPROVED” jars, Ball’s initial fruit jar production (Birmingham 1980:56; Roller 2011:654).<sup>3</sup> Since the patent was expired, the brothers were under no constraints. The plant suffered a disastrous fire in late 1885. The *American Glass Worker* (1885:2) stated that “E.B. & F.C. Ball’s glass works, Buffalo, was totally destroyed by fire on September 12th, together with a stock of glassware amounting to \$10,000.” Apparently, the Balls rebuilt the Buffalo plant.

The brothers incorporated as the Ball Brothers Glass Mfg. Co. on February 18, 1886,<sup>4</sup> with a capital of \$50,000. Frank Ball was president, with Edmund as vice president and George Alexander Ball as secretary and treasurer. The final two brothers, Lucius Lorenzo Ball and William Charles Ball, were not listed as officers, although they certainly became active in the firm later. The brothers used a seven-pot furnace for glass making but continued to manufacture cans and other tin products, although the plant also made some prescription bottles. Although no

---

<sup>2</sup> Frank Ball’s dates were not completely accurate. For example, he placed the incorporation at 1885, when it actually occurred on February 18, 1886.

<sup>3</sup> According to Roller (2011:654) these were probably the jars embossed with the BBGMCo monograms. Ball (1937:65-66) discussed the decision to make the Mason jars and threats of litigation that the brothers received from the Hero Fruit Jar Co. and the Consolidated Fruit Jar Co.; however, the patents really *were* expired, so nothing came of the threats.

<sup>4</sup> The *American Glass Worker* (1886:20) noted on February 26, 1886, that the Ball Bros. Glass Manufacturing Co. had filed a certificate of incorporation with the County Clerk at Buffalo, N.Y., on February 10 – not February 18. All secondary sources we have found noted the February 18 date. The *Glass Worker* date may have been a misprint, or the secondary sources may have all copied an error date.

documentation remains from the period, the so-called “Buffalo jars” – embossed with the BBGMCo monogram – continued to be made (Creswick 1987b:164; Okmulgee Historical Society 1985:454; Roller 1983:451-453; 2011:654).

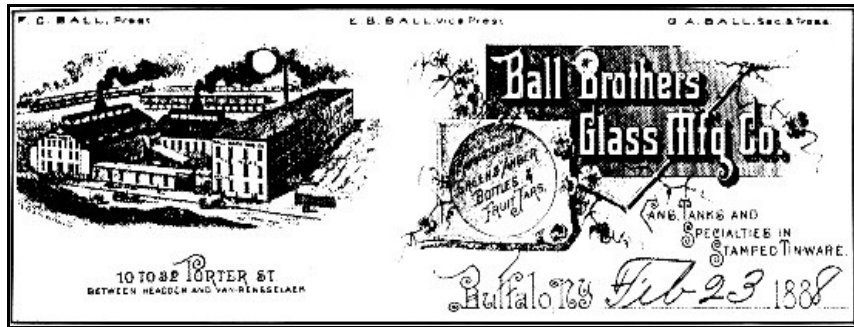

Figure 2 – Ball Brothers Buffalo letterhead (Bingham 1980:66)

Production at this time was limited to amber and green (aqua) glass, partly because emissions from the coal furnace permeated the glass pots – turning a normally colorless glass into amber (Figure 2). Along with the typical glass-blowing shops consisting of men and boys, the Balls also employed girls to wash and pack the jars. Listings for the brothers continued in the Buffalo directories until 1888, and Frank C. Ball stated that the brothers did not sever final ties with Buffalo until 1889<sup>5</sup> (Roller 1983:451-453; 1997; 2011:654).

### **Ball Brothers Glass Mfg. Co., Muncie, Indiana (1887-1922)**

The Ball Brothers became interested in moving the plant to a western location to take advantage of the newly opened gas wells. After a search by Frank Ball, the brothers selected Muncie, Indiana. In 1887, the Ball Brothers began construction on the Ball Glass Works at Muncie and made the first glass on March 1 of the following

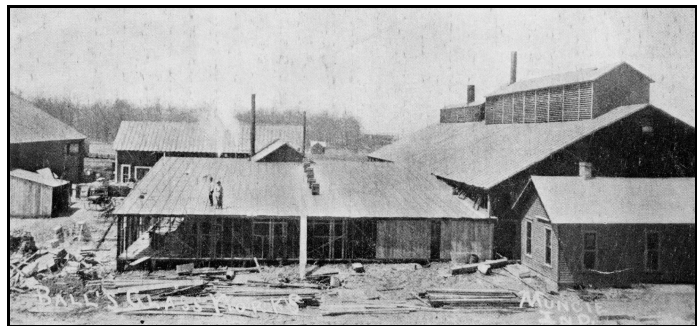

Figure 3 – Ball Brothers Muncie factory (Ball 1937:78)

---

<sup>5</sup> Roller (2011:656), however, stated that “Ball severed the last of its connections with Buffalo in December 1896 when they sold their sales office to R.G. Wright.”

year at one eight-pot furnace and a single day tank (Figure 3).<sup>6</sup> The following year, the brothers installed “a furnace with one open pot for making white liners” for the fruit jars. The furnace produced “600 dozen liners per press in 8 hours. The plant used two day tanks for making liners from 1889 to 1901, using 16 hand presses, producing 600 dozen each. The firm invented a power press in 1901 (Ball 1937:97).

A Pittsburgh company, H.L. Dixon & Co., built a continuous tank to replace the furnace in 1889. In a reorganization on August 19, 1890, the Ball Brothers purchased the entire stock of the earlier Ball firm (Roller 1999; 2011:655). Also in 1890, the brothers built a 16-pot furnace on 12<sup>th</sup> St. (known as Factory No. 2) to make flint bottles and packers’ ware. The plant was set to open at the end of February 1891, with a 14-pot furnace, an eight-pot furnace for green glass, and five “tank furnaces” (probably day tanks). The firm was still making jars, bottles, “jacket shipping cans,” and “grocers’ oil tanks” (Roller 1999). The Ball stamping department suffered ca. \$80,000 in damage from fire on October 28, 1891 (Birmingham 1980:80).

William F. Modes built a continuous tank for the brothers in 1892 and installed four more in the following few years. In 1893, the Balls bought the rights to the Arbogast patent. Arbogast had invented a press-and-blow machine to make wide-mouth bottles and jars and patented it on August 11, 1881. Daniel C. Ripley purchased the patent but was unable to use it due to union pressure. When Ripley’s firm, Ripley & Co., became part of the United States Glass Co. in 1891, the machine became the property of U.S. Glass and was transferred thence to the Ball Brothers (Lockhart & Bernas 2014:19-20).

The widow of John Arbogast brought suit against the Balls for patent infringement, and the court ordered the factories closed in May 1898 – pending the result of the suit. The decision, however, must have gone in the Balls’ favor. By 1899, Modes was installing Furnace No. 6 at Factory No. 1, and the firm shipped machine-made Mason jars to Norway and Sweden by June. One of the Ball workers noted that the Arbogast machine did not function well.<sup>7</sup> It is thus

---

<sup>6</sup> For a detailed discussion of the selection of Muncie, see Ball (1937:68-78).

<sup>7</sup> Although we have found no direct source for *why* the Arbogast/Ripley machines were problematic, no factory seems to have kept them in operation for long. As an example, the president of the Chesebrough Mfg. Co. testified that Vaseline jars made on the Arbogast/Ripley machine were of inferior quality (Scoville 1948:324).

questionable how many jars were actually machine made between 1893 and 1896 (Birmingham 1980:77; Creswick 1987b:164; Okmulgee Historical Society 1985:454; Roller 1983:451-453; 1999).

The Balls became involved with the Fruit Jar Sales Agency in 1896. The agency was formed by a combine of jar manufacturers to control prices, but it ceased its function by 1902. Meanwhile, Frank C. Ball and other engineers within the firm were developing Ball's own machines, with improvements into the 20<sup>th</sup> century (Birmingham 1980:77; Roller 1983:453-454; 2011:656). Modes built the fifth new tank for the Balls in the spring of 1897, and the brothers installed nine machines, patented by Jonathan Haley, at Factory No. 1. The machines were in operation by August 1899 (Roller 1999).

In 1897, the plant operated "five day tanks, 10 rings, and five continuous tanks, 47 rings, on fruit jars" (*National Glass Budget* 1897:5). About 1898, Ball introduced its first wire-bale closure and jar, but a disastrous fire destroyed Factory No. 2 in March. Six weeks later, a second fire caused \$250,000 to \$350,000 in damages to a new warehouse filled with fruit jars. This was also the year of a new Ball strategy – acquiring the competition. On June, 17, 1898, Ball purchased the Fort Wayne Glass Co. at Upland, Indiana – the first of many such takeovers<sup>8</sup> (Birmingham 1998:80; Roller 2011:656-657).

The brothers realized that the easiest way to deal with competition was to purchase the other firms. The Ball expansion continued during the early 20<sup>th</sup> century; the firm bought eight competitors between 1902 and 1909. See Table 1 for a list of acquisitions. At some point between 1902 and 1904, the brothers built Factory No. 3 to make flint bottles and packers' ware (Roller 1999).

---

<sup>8</sup> According to Roller (1999), the brothers incorporated as the Ball Bros. Glass Mfg. Co. of Muncie, Indiana, on March 24, 1899. Previously, the firm had operated as a partnership under New York law. Roller cited the *Crockery & Glass Journal* issue of April 6, 1899. This is contradicted by virtually all other sources, and we have found no way to resolve the discrepancy.

**Table 1 – Ball Brothers Buyouts**

Date Acquired	Former Name	Location
1898	Ft. Wayne Glass Works	Upland, IN
1901	Windfall Glass Co.	Windfall, IN
1904	Swayzee Glass Co.	Swayzee, IN
1904	Upland Glass Co.	Upland, IN
1904	Marion Fruit Jar & Bottle Co.	Marion, IN Converse, IN Fairmount, IN Coffeyville, KS
1904	Port Glass Works	Belleville, IL
1904	Loogootee Glass Works	Loogootee, IN
1909	Root Glass Co.	Terre Haute, IN
1909	Greenfield Fruit Jar & Bottle Co.	Greenfield, IN
1909	Mason Fruit Jar & Bottle Co.	Coffeyville, KS
1913	Texas Bottle Co.	Wichita Falls, TX
1925	Schram Glass Manufacturing Co.	St. Louis, MO Hillsboro, IL Huntington, WV Sapulpa, OK
1929	Pine Glass Corp.	Okmulgee, OK
1936	Three Rivers Glass Co.	Three Rivers, TX

The Ball Brothers negotiated with the Owens Bottle Machine Co. to obtain the licence for exclusive manufacture of fruit jars. E.D. Libby had informed the brothers on December 22, 1906, that their initial installment of the Owens Automatic Bottle Machines would be finished by February 1, 1907. Libby’s estimate for the building, tanks, power equipment, and four Owens machines was \$113,000 (Libby to Ball Bros. 1906). Probably because they were experimenting with their own machines, the brothers backed out of the deal, and the Owens company released the license to the Greenfield Fruit Jar & Bottle Co. Realizing their error, the Ball brothers bought the Greenfield firm on November 20, 1909.

It is clear that the Balls purchased the Greenfield factory to obtain the Owens license and the already-installed Owens machines. A Ball letter, dated March 12, 1910, stated: “We recently purchased the exclusive right for making Fruit Jars on the Owens Machines and purchased the out-put of the Greenfield Factory where these machines are now operated” (quoted in Roller 1994:40). The Ball Brothers ran the plant under the Greenfield name and installed Owens machines in other settings as soon as they could, leasing the Ball Factory No. 2 at Muncie, Indiana, to Greenfield and installing three Owens AD, nine-arm machines there in late 1910 (Roller 1994:40). For a discussion about Owens machines, see Lockhart et al. 2010.

Collectors have long suspected that jars with “BOYD” changed to “BALL” reflected the Greenfield factory (e.g., Brantley 1975:24, 27). A March 10, 1910, letter from Ball Brothers to a customer removes any possible doubt that the jars:

were made on the Owens machine in the Greenfield plant where all the Owens machine Made Jars have been made . . . When we purchased the out-put of the Factory and assumed the contracts we changed the lettering on the Jars and on the boxes from ‘Boyd’ to ‘Ball’ because the name ‘Ball’ is better known and generally preferred . . . the jars are all made on the same machines in the same Factory and if there is any difference, those that have been made last and bear the “Ball’ name are the better, for the workmen have learned something by experience. (quoted in Roller 1994:40)

Ball operated the plant until May 1915 and sold it to the Owens Bottle Machine Co. by November 14, 1916. Owens operated the factory until 1921 (Roller 1994:41; Toulouse 1971:396).

### **Ball Brothers Co., Inc. (1922-1987)**

Between 1913 and 1929, Ball acquired four more of its competitors and reorganized again on December 19, 1922, as the Ball Brothers Co., Inc. The firm replaced the now-outdated Owens machines with Ball-Bingham, Miller JPM, and English Moorshead machines in the 1930s. The firm purchased the Three Rivers Glass Co. in 1936 and closed it down after filling existing orders, a fate visited on many of the earlier acquisitions (Roller 1983:456-457; 2011:659; Smith 1989; 1996).

The Owens license expired in 1933, so Ball began negotiations with Hartford-Empire and acquired a license for those machines on March 25. On January 8, 1935, Ball executive Fred Petty announced that Ball would begin production of packers' ware in response to a major decline in fruit jar sales over the past three years (Birmingham 1980:115). Ball (1937:96) illustrated a birds-eye view drawing of the Muncie plant in 1936 (Figure 4).

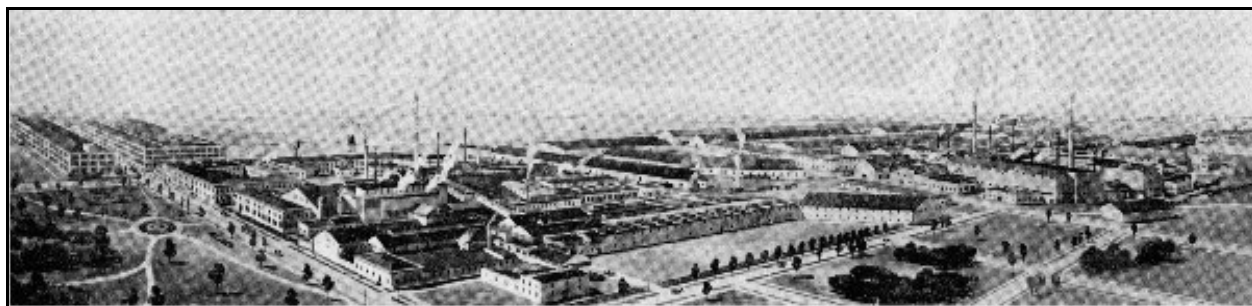

Figure 4 – Muncie plant – 1936 (Ball 1937:796)

By 1937, the Ball Brothers made “fruit jars, packers and preservers ware, bottles” by machine at 14 continuous tanks – reflecting the list of five factories at Muncie, Indiana; Wichita Falls, Texas; Huntington, West Virginia; Hillsboro, Illinois; and Okmulgee, Oklahoma (*American Glass Review* 1937:81). On December 11, 1939, the U.S. Government sued the Ball Brothers, the Hazel-Atlas Glass Co., and the Owens-Illinois Glass Co. under monopoly charges based on the Hartford-Empire and Owens licensing agreements. The plaintiff claimed that small producers were being frozen out of business or prohibited from entering manufacture by the nature of the licenses.

Almost a decade later, in 1947, the justices rendered a final verdict. The court prohibited the Ball Brothers from purchasing or otherwise controlling any other businesses engaged in the same manufacturing processes – in other words, the small jar producers. In addition, Ball had to divest itself of the Three Rivers Glass Co. (already closed for almost a decade) that Ball had acquired in 1936. Ball sold the property (Birmingham 1980:115-116).

Beginning in 1942, Ball shifted production to other glass containers, zinc shells for batteries, and various rubber products – in addition to fruit jars – to support the World War II effort (Birmingham 1980:116). Muncie Plant No. 1 burned in 1945. By 1952, fruit jar production made up less than 10% of sales (Birmingham 1980:153, 159).



The rest of the decade was mostly quiet, with no notable changes. The firm opened the Mundelein, Illinois, plant in 1961 and ended glass making at the Muncie plant the following year<sup>9</sup> (Roller 1999; Simpson 1962:63). The plant that saw the greatest fruit jar production in U.S. history was over – as was the need for most of the jars it had produced.

### **Ball Corp.**

Another reorganization in July 1969 caused a new name change to the Ball Corp. The Balls next bought the Metropak Container Corp. in 1980 (Roller 1983:457).

### **Later Ball Reorganizations (1987-1997)**

In May 1987, Ball merged with Indian Head Container Corp. to form the Ball-InCon Glass Packaging Corp. Ball-InCon announced in November 1991 its plans to buy assets of the Kerr Glass Mfg. Co., and the actual transfer occurred in mid-1992 (Owen-Illinois 2001; Roller 2011:660-661; Whitten 2013).

Another reorganization created the Ball Glass Container Corp. in 1994. Just a year later (1995), St. Gobain acquired 58% of the assets of the company and merged it with the Foster-Forbes Glass Co. to create the Ball-Foster Container Corp. St. Gobain purchased the remaining interest in late 1995 or early 1996, eliminating Ball from the ownership of the company entirely, although the Ball-Foster name continued to be used until 2000. The former Ball plants are now part of the St. Gobain Container Corp. (Owen-Illinois 2001; Roller 2011:661-663; Whitten 2013).

For more information about the Ball Brothers, see Ball (1960), Roller (1983:434-436; 2011:653-662), or Toulouse (1969:357-361). See Table 2 for a chronology of the Ball companies.

---

<sup>9</sup> Bingham (1980:159) stated that Ball closed the Muncie plant on December 13, 1959.

**Table 2 – Chronology of Changes in Company Names**

Firm Name	Location	Dates
Ball Brothers	Buffalo, NY	1884-1886
Ball Brothers Glass Mfg. Co.	Muncie, IN	1886-1922
Ball Brothers Co.	Muncie, IN	1922-1969
Ball Corp.	Muncie, IN	1969-1987
Ball-InCon Glass Packaging Corp.	Muncie, IN	1987-1994
Ball Glass Container Corp.	Muncie, IN	1994-1995
Ball-Foster Container Corp.	Muncie, IN*	1995-2001

\* Ball-Foster moved its headquarters to Denver, Colorado in 1998 (Roller 2010:663).

### Ball Brothers Machines

The Balls began machine use when they acquired the rights to the Arbogast machine in 1893, although most production probably continued by hand methods. The brothers installed nine machines, patented by Jonathan Haley, at Factory No. 1 in 1898, and those were in operation by August of the following year (Roller 1999). Because of difficulties with existing machines, the Ball Brothers began using their own in-house inventions.

Jonathan Haley patented a number of glass-related inventions between the 1870s and the early 1900s. The machines ordered by the Balls could only have been one of two patents, both for machines designed by Jonathan Haley and H.H. Bridgewater. The first and by far most likely was a machine filed by the pair on August 18, 1899. The invention, however, did not receive Patent No. 693,130 until February 11, 1902.

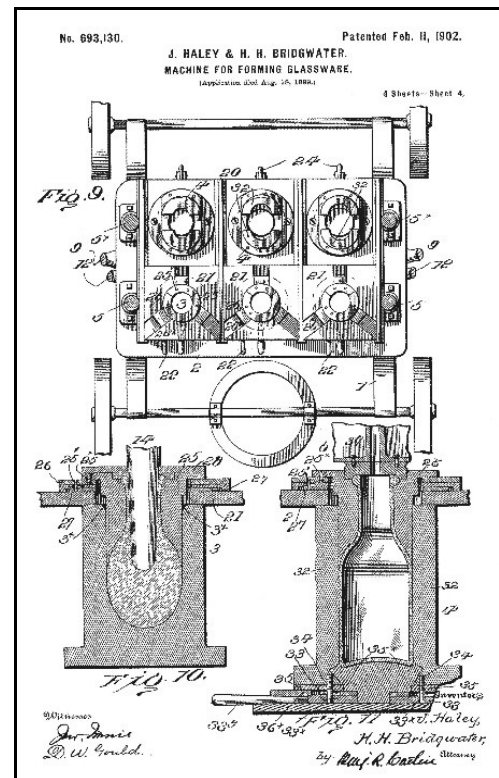

Figure 5 – Haley-Bridgewater 1902 patent

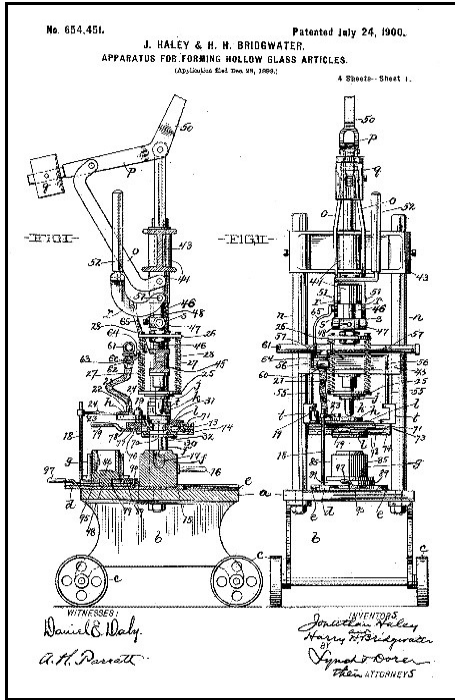

Figure 6 – Haley-Bridgewater 1900 patent

The machine used the press-and-blow process, but the actual molds operated a bit differently from those found on other press-and-blow machines. A typical machine formed the finish during the first (press or parison) stage, then transferred the parison (first stage) to the blow mold. The Haley-Bridgewater machine formed the finish, neck, and shoulder during the parison stage, then transferred it to the blow mold. This should leave a seam around the base of the shoulder or just below it (Figure 5).

The inventors applied for a patent for another machine on December 28, 1899, and received Patent No. 654,451 on July 24, 1900. Thus, the first machine received its patent 18 month *after* the one with the later application. This, too, was a press-and-blow machine, using similar technology to form the finish, neck, and shoulder in the parison stage. Jars made on this machine,

too, should have a seam around the shoulder (Figures 6 & 7).

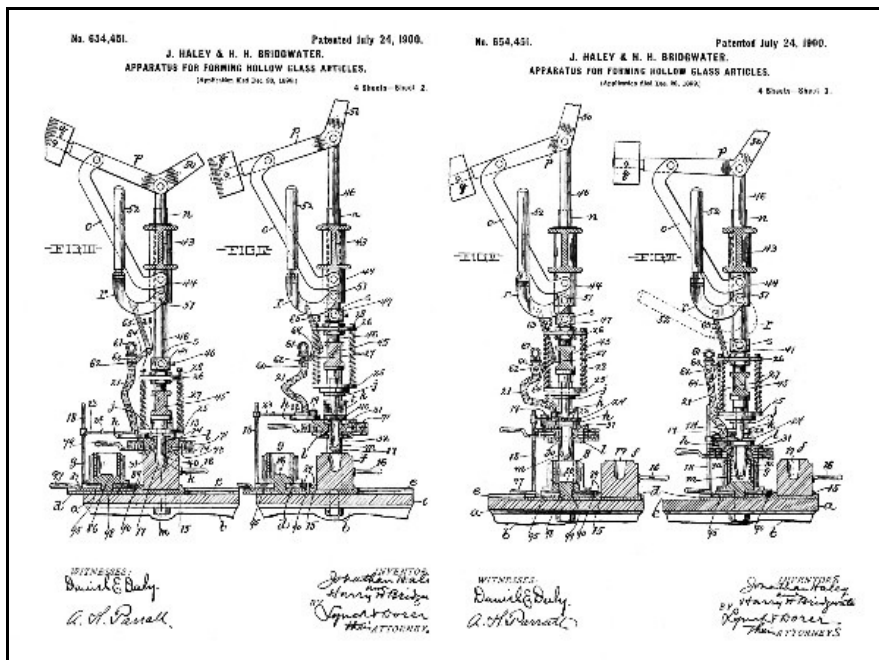

Figure 7 – Detail of Haley-Bridgewater 1900 patent

On August 26, 1897, Alvah L. Bingham applied for a patent for a “Glass-Blowing Machine.” He received Patent No. 608,022 on July 26, 1898. Bingham stated that “the object of my said invention is to produce a machine by means of which articles of glass, such as fruit jars and the like, may be rapidly and uniformly produced with but a

comparatively insignificant amount of manual labor.” Judging by the large number of handles shown in the drawing, the “amount of manual labor” was still pretty great compared to later machines (Figure 8). Bingham assigned this and his succeeding patents to the Ball Brothers.

Frank C. Ball followed with a machine that was specifically designed to improve on the Bingham patent. Ball applied on December 16, 1897, and received Patent No. 610,515 for a “Glass-Blowing Machine” on September 6, 1898 (Figure 9). Ball named the invention the “F.C. Ball machine” (Ball 1937:87). Frank Ball (1937:87-88) explained:

The operation of this machine required a gatherer, a presser, a take-out boy, and a carry-in boy. A gatherer gathered the glass from the furnace on the end of a punty (gathering iron) which he held over a press mold on the revolving machine table.

The presser cut the required amount of the glass from gather which dropped into the press mold; the presser then shifted a valve handle and a plunger was forced into the mold, pressing the glass in the form of a blank; the presser then lifted the blank from the press mold by means of a ring mold and placed it in the blow mold. Compressed air was admitted and the blank was blown into the shape of the blow mold.

The table was then revolved one stage, the mold opened and the jar removed by the take-out boy and carried to the Lehr.

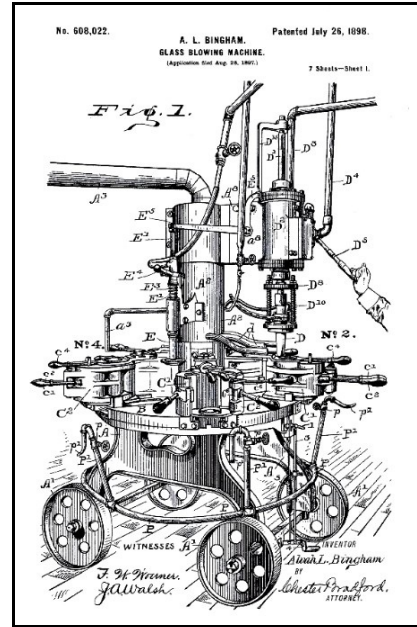

Figure 8 – Bingham’s 1898 patent

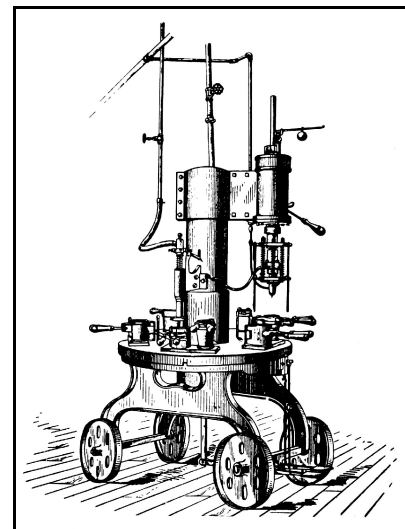

Figure 9 – F.C. Ball machine (Ball 1937:87)

The jars made on this pressing and blowing machine were finished complete, doing away with a blow-over, the work of chipping off the blow-over, and the work of grinding the jars, thus making a much smoother and better jar in every way, increasing the production and reducing the cost.

One or both of these machines was almost certainly in use by early 1898, if not late 1897. Edmund B. Ball added still more improvements to essentially the same machine, when he applied on October 31, 1898, for a patent for a “Glass Blowing and Pressing Machine.” It was not until February, 27, 1900, however, that he received Patent No. 644,395 for his invention.

On December 12, 1904, Bingham filed for a patent with an entirely new design. He received Patent No. 817,745 for his new machine on April 17, 1906 (Figure 10). Frank Ball (1937:88) noted that the “Ball-Bingham

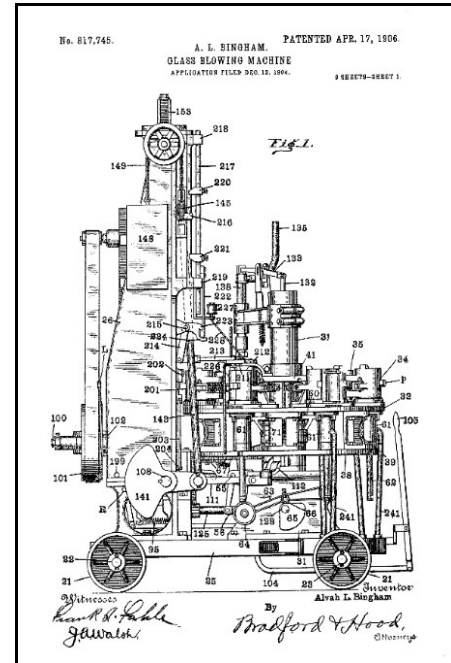

Figure 10 – Bingham’s 1906 patent

machine, requiring only one gatherer and one take-out boy, further increased the production and reduced the cost.” Bingham’s next improvement, filed January 14, 1910, received Patent No. 917,587 on October 4 of that year. These were all apparently intended for use with jars or wide-mouth bottles, and the final one was apparently known as the Ball-Bingham machine (Brantley 1975:16).

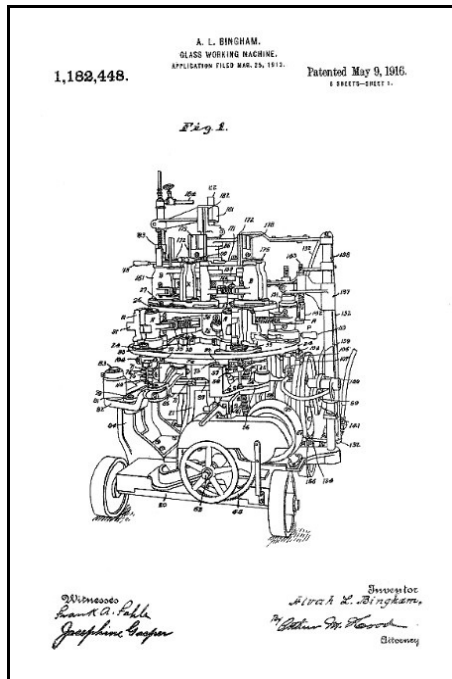

Figure 11 – Bingham’s 1916 patent

Bingham entered the world of small-mouth bottle production on March 25, 1913, when he applied for a patent for a “Glass-Working Machine” to make these more difficult containers. He received Patent No. 1,182,448 on May 9, 1916 (Figure 11). A further improvement received Patent No. 1,340,366 on May 18, 1920.

By the time of these later patents, the Ball Brothers had already acquired the rights to the Owens Automatic Bottle Machines when they bought the Greenfield Fruit Jar & Bottle Co. on November 20, 1909. Since the early Owens contracts were exclusive, Ball was the only glass house allowed to use the machines for fruit jar production. Most of the Owens machines had been phased out by the mid-1920s.

Frank Ball (1937:93) discussed an improvement in the Ball-Bingham machine that the plant made in 1923 but failed to patent. He noted that

in place of the combined telescopic press and blow molds we arranged the press molds to lower and raise to a connection with the ring molds independent of the blow molds, which was a great improvement and eliminated the trouble that we experienced in forming the sealing shoulder with the telescopic molds. This improved machine is known as our small Ball machine.

The firm further invented the “Jewett-Ball Air Gob Feed which is covered by Patent No. 1,812,534 dated June 30, 1931” (Ball 1937:93). Fred E. Jewett applied for a patent for a “Method and Apparatus for Feeding Molten Glass” on June 11, 1928, and received Patent No. 1,812,534 on June 30, 1931. Jewett assigned the patent to the Ball Brothers.

In addition to their own inventions and the Owens machines, the Balls also installed JPM Miller machines during the 1920s and purchased “the exclusive American patent rights of the “Moorshead” Continuous Revolving Press and Blow Machine” from the United Glass Bottle Manufacturers, Ltd., of London in 1934. Ball (1937:94) described the machine as “similar in its movement to the Owens machine with the exception of sucking the glass into the forming molds from a revolving pot. The glass is fed into the molds in gobs with the Ball gob feeder.” The Moorshead machine used the press-and-blow system and thus only made wide-mouth containers.

### **Containers and Marks**

Although Ball jars were made in a variety of colors, “Ball Blue” stands out as unique, although Brantley (1975:33) cited Edmund B. Ball that all of the early colors (mostly aquas, greens, and blues) as well as the Ball Blue “were variations occurring naturally according to origin of ingredients and were not ‘controlled’ colors.” Roller (1983:25; 2011:46) explained:

By about 1910, a new deep blue-aqua began to replace the old aqua shade. This blue-aqua is referred to by the hobby as “Ball blue.” At the beginning of the three decade period (1900-1930), most of the jars produced were in the “Ball Blue” color. By the middle of that period, clear jars became more common and by about 1937 the last of the production of “Ball blue” jars had been made.

The sand that created Ball blue came from the Hoosier Slide sand dune. Commercial sand mining of the dune commenced ca. 1890, and such glass houses as the Ball Brothers, Pittsburgh Plate Glass, and Hemingray Glass Co. used the sand to create products with the distinctive blue color. The dune had disappeared by 1920, although the Balls had enough of a supply to last most of the next decade (Kepshire 2012).

Roller (1983:25; 2011:46) discussed eight major changes in Ball logos, along with several other datable features. He noted that the Ball Brothers used no logo at all during the ca. 1888-1895 period. Among other categories, Ball jars may be segregated by manufacturing style (mouth-blown, machine-made, type of machine), round or square shape in cross-section, with or without “gripper bars” (a design patent purchased from the Brockway Glass Co. in 1933), and the presence or absence of embossed graduations.

Frank Ball (1937:118-119) described the method used by the Ball employees for blowing jars into a mold:

The workmen were divided into shops—two blowers, one gatherer, one mold boy, one boy to carry from molds to tempering ovens [the forerunners of lehrs], and one oven laying-up boy. The task of a shop was to work out a pot during the day. In the case of the jars the gatherer gathered the required amount of glass on the end of the blowpipe by revolving it in the molten glass; he then passed the blowpipe to the blower who formed the glass pear shaped on the end of the blowpipe and then, by blowing and swinging the glass through the air, produced an oblongated hollow form which was then lowered into the mold and blown to the shape of the mold. The surplus glass was blown over the top and formed what was called the blow-over. The jar was then taken from the mold, placed on a “buck” and carried to the tempering oven.

The tops of the jars were broken off with a file and then placed on a grinding machine and with sand and water the tops were ground smooth. The jars were then packed in six-dozen and eight-dozen cases.

Many of the Ball glass and lacquered metal inserts are also datable. Roller (1983:51-52; 2011:86) illustrated and dated three glass and nine metal lids.

## ABGA

Toulouse (1969:13-14) described an aqua machine-made jar with “ABGA” on the front. Roller (1983:1; 2011:11) noted three variations of the jar (a fourth in the updated edition):

1. ABGA (cursive) / MASON / PERFECT (all horizontal)
2. ABGA (cursive) / MASON / PERFECT / MADE IN U.S.A. (all horizontal)
3. Same as #2 but with PERFECT in a rectangular plate extending from seam to seam

At least one lid was embossed “MADE IN USA (arch) / ABGA / TRADE MARK (inverted arch).” The central motif was divided by a large plus sign (+) with “A” in the upper left quadrant, “B” in the upper right, “G” in the lower left, and “A” in the lower right. Roller (1983:1; 2011:11) noted that the Ball Brothers made all three variations, some of which had Owens scars.

Since only the Balls had the license to make fruit jars on Owens machines, the manufacturer of these was not in question. He further explained that the Hazel-Atlas

Glass Co. also made a version of the second variation that was 3/8" shorter than the Ball jars (Figure 12). The initials indicated the Anglo-Belge Glass Association of London, England.

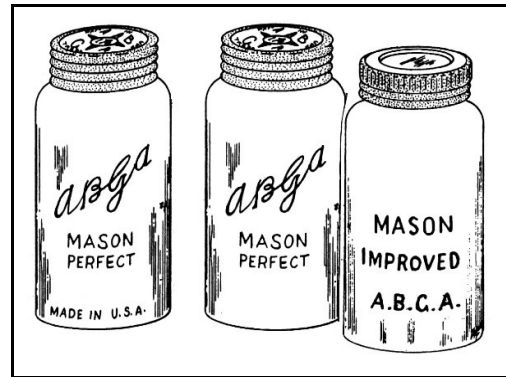

Figure 12 – Mason Improved jar with ABGA logo (Creswick 1987b:1)

## BALL BROS. GLASS MFG. CO. (1886-1888)

The Ball Brothers Buffalo plant made jars embossed “MASON’S (arch) / PATENT / NOV 30<sup>TH</sup> / 1858 (all horizontal)” on the front. These were sealed with metal bands and glass inserts. The inserts were embossed “BALL BROS. GLASS MFG. CO. (arch) / BUFFALO, N.Y.



(inverted arch)” – although at least one variation lacked the “N.Y.” initials. These were made after the 1886 incorporation but prior to closing the plant in 1888 (Figure 13).



Figure 13 – Glass inserts from Buffalo (eBay)

### BBGMCo monograms (1885-ca. 1887)

According to Toulouse (1969:358), the Ball Brothers produced “several so-called ‘Buffalo’ jars” embossed with “at least two versions of a rather crude monogram of BBGMCo on the sides.” The main two variations illustrated by Toulouse (1969:42-43) depended on the placement of the “o” in “Co” and the relative size and positions of the “C” in “Co” and the “G.” A sub-variation on one included serifs on the “M” and “C,” with an upper serif on the “G.” He noted that the jars were only made in 1886 and 1887. The containers were mouth blown with ground lips, in green and aqua colors.

Roller (1983:61-62; 2011:54, 97) dated the jars 1885-1886 and noted that they were “the earliest fruit jars Ball made.” He also discussed reproduction jars that were mouth-blown by Joe Miller and his helpers at the Indiana Glass Co. beginning January 6, 1976. These were embossed “AN HISTORIC REPRODUCTION MUNCIE, INDIANA – 1976 No. 1 THE AMBER BUFFALO JAR” around “Ball” in a square logo in the center.

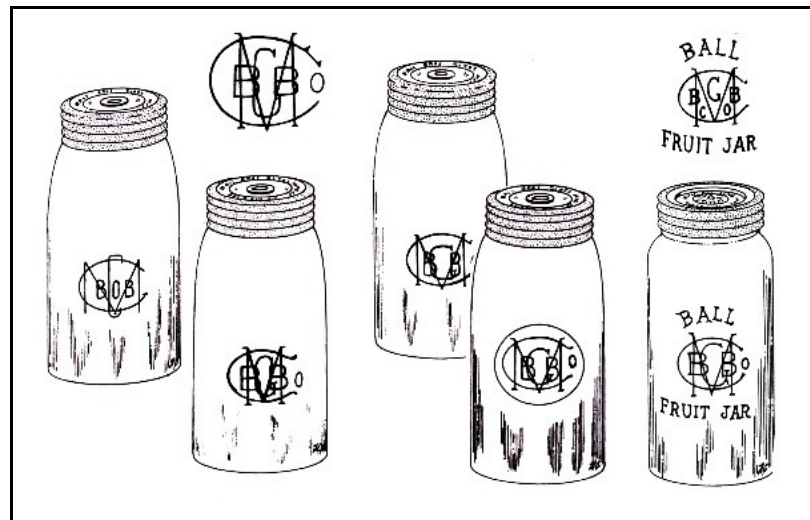

Figure 14 – Variations in BBGMCo monograms (Creswick 1987b:11)

Creswick (1987a:11) agreed with the Roller dates (including the reproduction) and illustrated seven variations of the monogram (Figure 14). Creswick (1987b:19) also described and illustrated another monogrammed jar, made to commemorate the Ball Guest House in 1982 (Figure 15). Brantley (1975:3), too, concurred.

**BALL or Ball (cursive) (1887-1987)**

After the monogram was discontinued – followed by the “unmarked” period (1888-1895) – the firm simply used the word “Ball” to identify its containers. The logo went through seven major changes as well as several minor ones. Initially, the name was embossed in two variations: block capital letters, and a horizontal, underlined script. The script signature became slanted ca. 1896 and remained at an angle throughout the succeeding changes. Roller (1983:25; 2101:46) provided a dating guide to the variations. Characteristics of the different Ball logos include the shape of the letter

“B”(including the curl where its curved line crosses the downstroke), the presence or absence of the “downstroke-a” or “dropped-a,” and the shape, presence, and/or absence of the underline (Figure 16).

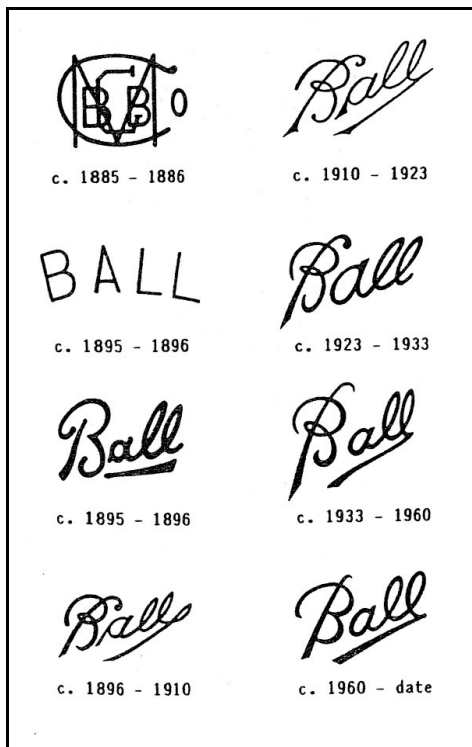

Figure 16 – Ball logo variations (Roller 1983:25)

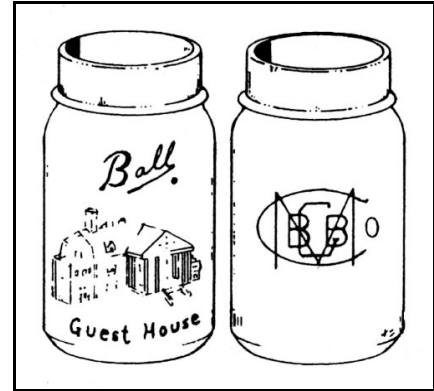

Figure 15 – Guest House commemorative jar (Creswick 1987b:19)

We will not attempt to cover the myriad types, styles, and variations of jars produced by the Ball Brothers. The two best references for finding, identifying, and dating Ball jars are (Creswick 1987a:11-13; 1987b:11-27) and Roller (2011). The Roller volume has 53 pages (pp. 46-97) devoted to the variations of the Ball name on jars. For examples of the main variations, see Figures 17-24.

Of special interest, however, are the altered labels. Some of the factories acquired by Ball were already producing jars by machine and had a considerable inventory of molds in use. Where Ball was able, the firm

converted the molds from the original embossed labels to an altered Ball logo. Some of the changes were comical. Vivian “Granny” Kath (1997:48-49) created her own dating guide for the Ball signature that included some of the conversions (e.g., No. 7, No. 9, and No. 13 in Figure 17). See Table 3 for a list of altered Ball jars. The firm produced some error jars, such as one triple-L Ball example with an upside-down embossed label (Figure 18).

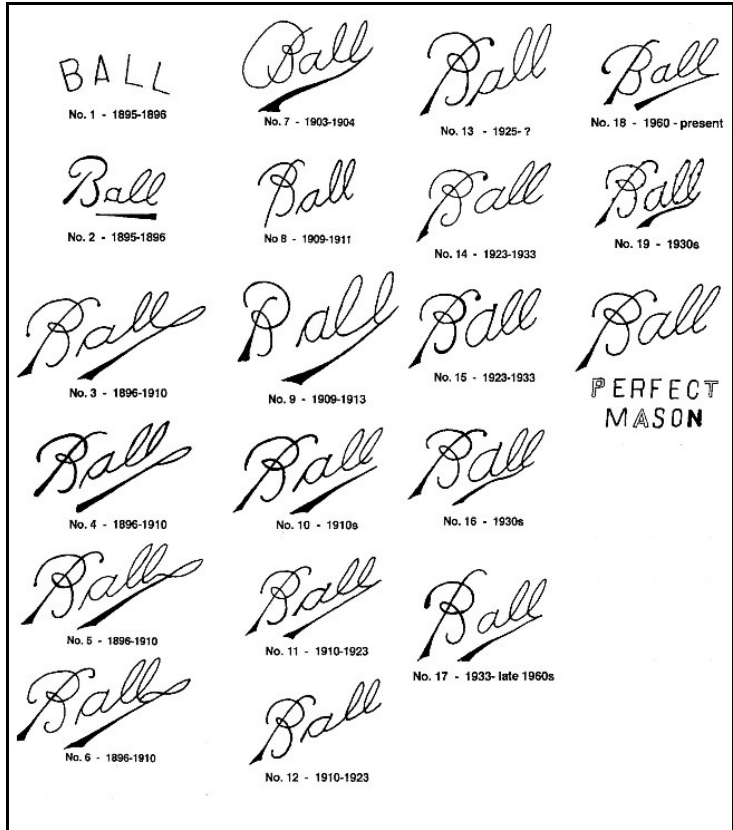

Figure 17 – Ball logo variations including conversions (Kath 1997:48-49)



Figure 18 – Upside-down label (North American Glass)

**Table 3 – Ball Conversions from Other Manufacturer’s Marks**

From	To	Company	Dates
Port	Ball script	Port Glass Co.	1904-?
Root	Ball script	Root Glass Co.	1909-?
BOYD	BALL	Greenfield Fruit Jar & Bottle Co.*	1909-?
<i>BOYD</i>	<i>BALL</i>	Greenfield Fruit Jar & Bottle Co.*	1909-?
Drey	Ball script	Schram Glass Mfg. Co.	1925-?
PINE	BALL	Pine Glass Co.	1929-1930

\* According to Brantley (1975:24), jars with this change were “remakes of Boyd mold[s] which were acquired with the purchase of the Greenfield Fruit Jar & Bottle Co., which has some type of arrangement Illinois Glass Works, the maker of the Boyd.”



Figure 19 – Ball Standard

One other unusual jar type deserves a brief mention. The grooved-ring wax-sealer fruit jars were some of the earliest ones, and they were generally phased out during the few years of the 20<sup>th</sup> century. Virtually all of them – prior to those made by Ball – were mouth blown and finished with a special tool. The Ball Standard, however, was one of the few machine-made wax



Figure 20 – Machine seams on wax-sealer finish



Figure 21 – Machine scars on wax sealer bases

sealers. These were made by both Ball-Bingham and Owens automatic machines during the first decade of the 20<sup>th</sup> century (Figures 19-21). The jars were discontinued in 1912 (Roller 2011:89-90). Creswick (1987a:13) illustrated and discussed five variations, all machine made between ca. 1895 and 1912. These included two different Ball cursive logos (Figure 22).

## Reasons for Logo Changes

Although past manufacturer’s logo researchers seem to have rarely taken this approach, the Bottle Research Group attempts to find logical reasons for the selection of such marks. Changes in logos generally

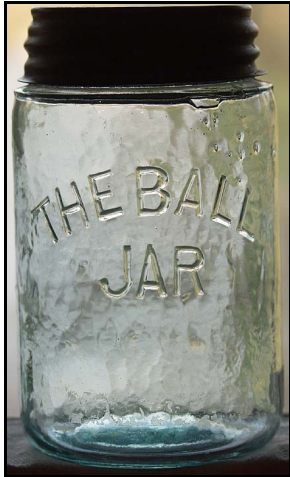

Figure 23 – Early Ball – 1895-1896 (North American Glass)

result from a reorganization or sale of a company, but they also commemorate the adoption of new products or a shift to machine manufacture.

Occasionally, the reason is so obscure or counterintuitive that we never discover it, but the change is usually logical and rational.

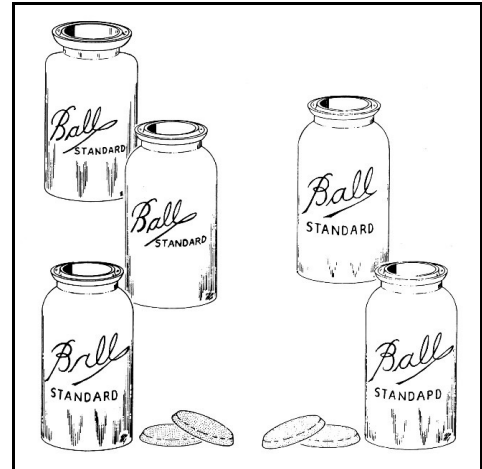

Figure 22 – Ball Standard variations (Creswick 1987a:13)

As noted above, Roller (1983:25) illustrated a chart with seven changes in the “Ball” logo. We have attempted to explain a reason for each logo adoption as a method of testing Roller’s dates. He dated the first two marks – Ball in block letters and the first cursive Ball – ca. 1895-1896. According to Creswick (1987a:11), all of the jars with both of these logos were mouth-blown (ground lips).

Why the Ball Brothers began using both the block and first cursive logos (Figures 23-25) is not known to us. There seems to be nothing noteworthy in Ball history during the early to mid-1890s. Although the Balls joined the Fruit Jar Sales Agency in 1896, that was hardly a likely motivator to discontinue these two early logos.



Figure 24 – First cursive – 1895-1896 (North American Glass)

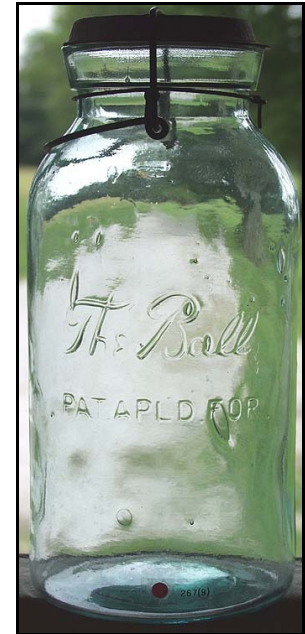

Figure 25 – Variation of first cursive (North American Glass)

The so-called triple-L Ball logo had cursive letters slanted forward, a decorative curl at the top of the “B,” a “downstroke-a” or “dropped-a,” and a distinctive curl at the beginning of the underline – the third “l” (Figure 26). This mark – used from ca. 1896 to 1910, according to Roller’s timetable – was probably machine related. In 1897, Bingham applied for his first machine patent, and the brothers may have installed the initial machine that year. Bingham received the patent the following year. Creswick (1987b:11-22) shows 12 pages of jars with triple-L Ball logos each with a “smooth lip” – i.e., machine made. Although we consider the serious entry into machine production as the likely impetus for the adoption of the triple-L logo, this was also the time when the firm introduced the first wire-bale jar.



Figure 26 – Triple-L Ball – 1896-1910



Figure 27 – Dropped-a and underlined – 1910-1923 (North American Glass)

The third major change (ca. 1910-1923) altered the “third L” into a simple line but retained the “downstroke-a” or “dropped-a” – while adding embellished serifs to the feet of the “B,” “a.” and the underline (Figure 27). The timing again points to machines. In 1909, the Balls purchased the Greenfield Fruit Jar & Bottle Co. in order to obtain the Owens Automatic Bottle Machine license. The following year, the firm began installing the machines at Muncie.



Figure 28 – No dropped-a; no underline – 1923-1933 (eBay)

The next alteration dropped the dropped-a, eliminated the serifs, and removed the underline (Figure 28). Roller placed this set from ca. 1923 to 1933, and, this time, the reason is clear: the reorganization as Balls Bros. Co., Inc. in 1922. One of the most common reasons for logo changes is the celebration of a new organization.



Figure 29 – Underline but no dropped-a – 1933-1960 (North American Glass)

The underline was back in 1933 (Figure 29), the year that the Owens machine license expired, and the Ball Brothers signed a new contract with the Hartford-Empire Co. Once again, the Ball Brothers logo change seems to be connected to machines.

The final logo was adopted ca. 1960. The major change in this final mark consisted of the removal of the curl in the center of the “B” (Figure 30). The timing on this one is again pretty certain. In 1961, the firm opened a new headquarters plant at Mundelein, Illinois and closed Munsie plant a year later. The final days of the venerable factory were undoubtedly responsible for this last adoption. The logo remains in use. See Table 4 for a chronology of “Ball” label changes and reasons.



Figure 30 – No curl in B – 1960-present

**Table 4 – Roller’s Logo Dates and Related Events**

Logo	Roller Dates	Related Events
Ball (block)	1895-1896	Arbogast machine (1893); Bingham patent applied (1897)
Ball (first cursive)	1895-1896	same as above
3-L Ball	1896-1910	Bingham patent applied (1897); received (1899); 1 <sup>st</sup> wire-bale jar (ca. 1898)
Ball – dropped A	1910-1923	Greenfield Fruit Jar & Bottle Co. (1909); installed Owens machines (1910)
Ball – no underline	1923-1933	Balls Bros. Co., Inc. (1922)
Ball – underline & B curl	1933-1960	Owens license expired (1933); Hartford-Empire licence (1933); beginning of packers’ ware production (1935)
Ball – no curl in B	1960-present	Opened Mundelein plant (1961); closed Munsie plant (1962)

## BI (1987-1994)

During the 1987-1994 ownership by the Ball-InCon Corp., the firm used a “BI” logo – a stylized “B” with a small letter “I” inside lower loop of “B” (Emhart 1992:48; Whitten 2013 – Figure 31).

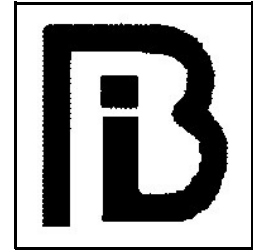
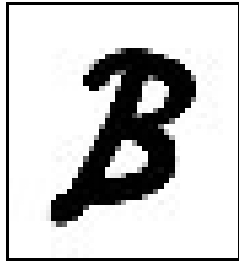

Figure 31 – Ball-Incon logo (Emhart 1992:48)



## B in cursive (1994-1995)

During the brief tenure of the Ball Glass Container Corp. (1994-1995), the plants used a cursive “B” to mark its bottles (Whitten 2013 – Figure 32).

Figure 32 – Cursive “B” (Whitten 2013)

## BF (1995-2001)

The change of ownership to St. Gobain and the merger with Foster-Forbes created Ball-Foster, which used the BF mark from 1995 to 2001 (Roller 2011:662; Whitten 2013).

## SG (2001-present)

Containers made by the former Ball plants have used the SG mark since 2001 (Whitten 2013 – Figure 33).



Figure 33 – SG on jar heel

## Lustre

These jars were made for the R.E. Tongue & Bros. Co., Inc. of Philadelphia. The jars were embossed “Lustre / R.E. TONGUE & BROS. CO. / INC. / PHILA.” in a round plate at the front body. According to Brantley (1975:46-47), the jars were made by the Ball Brothers ca. 1930. Roller (2011:300) included several variations and agreed that they were all made by the Ball Brothers. However, Roller dated the jars ca. “1910s-1920s.” The jars are definitely manufactured in the “Ideal” style (Figure 34).



## Liquor Number

In 1934, the federal government required that all glass houses making liquor containers emboss a warning that the bottle could not be re-used. In addition, every firm that met the requirements was assigned a permit number. Each liquor bottle from late 1934 to 1964 had to be embossed with the glass house liquor permit number, the glass house logo or initials, and a date code. Although we have not traced any possible earlier number, Ball used Permit No. 73 in 1953 but had changed to 161 by the late 1960s. Every time Ball acquired a glass plant (after 1934), the firm also received the liquor number for that company – if the glass house had made liquor bottles.



Figure 34 – Lustre  
(Creswick 1987a:84)

## Discussion and Conclusions

In researching most glass houses, the problem we face is a lack of information. With the Ball Brothers, the issue is the opposite – an overabundance of data, much of it conflicting. In the history section, we have attempted to weed through the sources and present the most relevant and most likely correct narrative about the Ball Brothers. Our emphasis, of course, is on glass production rather than the earlier can manufacture or the later delving into other fields.

The huge variation in Ball jars is far beyond the scope of this work. Tracking down individual jars requires either one of the Creswick volumes (1987a; 1987b) that were also reprinted in 1995 or one of the Roller books (1983; 2011), the most recent one of which remains in print as of this writing in 2013. The Creswick reprint appears to be identical with her earlier volumes, but the newer Roller book is a massive revision on the 1983 original, adding information from Dick Roller's immense collection of notes, plus research by the editors and Tom Caniff. Both Leybourne (2008) and McCann (2014) have data on variations, but they are both price guides with limited historical information.

We have concentrated on the manufacturer's marks used by the Ball Brothers and their successors. Roller (1983:25) and Kath (1997:48-49) have presented the best guides for dating the variations in the Ball trademark, and we have assessed Roller's dates to ascertain the reasons for the changes. Our conclusions support Roller's findings. We have also added later marks. At

this point, the series of glass concerns growing from the Ball Brothers is probably the most researched glass container manufacturing unit in the United States.

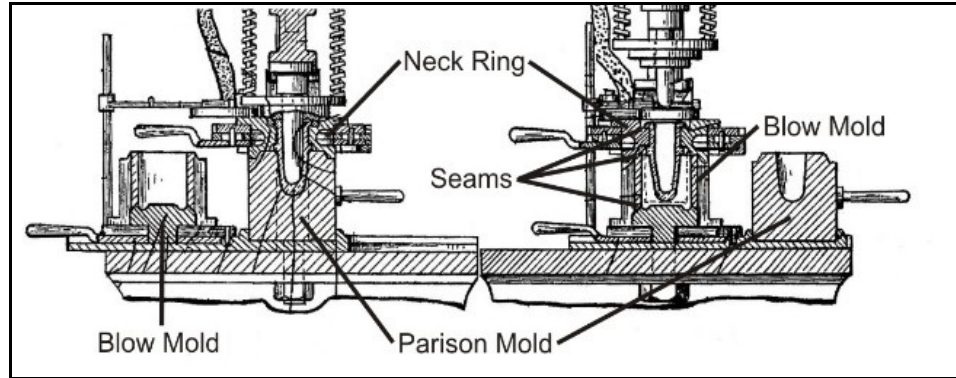

Figure 35 – Close view of molds from Haley-Bridgewater machine

A final interesting feature of this research is a ramification based on the drawings of the Haley-Bridgewater machines (Figure 35). Assuming that the mold joints illustrated in the drawings match those created by the actual machines, these should leave visible seams on the finished jars. Like many others, these jars should have a horizontal seam around the center or bottom of the finish, although this is not a diagnostic feature. The second horizontal seam, created where the neck-ring segment met the blow mold, should be visible as a distinctive seam around the jar body just below the shoulder. Very few semiautomatic (or fully automatic) container machines left a seam at this section of the body.

The base would have had a cup-bottom, with a horizontal seam around the heel – again a typical feature. However, these machines would have left *no* scars of any kind on the base – neither the off-center, feathered scar of the Owens machine nor the valve or ejection mark of the typical press-and-blow machine. Although a few of the early machines (e.g., the Blue machines used by the Hazel and Atlas plants) left no basal scars, those are exceptions. The combination of the shoulder seam and no basal scars would be a good indicator of the Haley-Bridgewater machines.

Seams typical of the Haley-Bridgewater machines may be visible on some Ball jars made after 1899. These should only include jars with the “triple-L” Ball mark (see Figure 26). This could add one more level of identification for Ball collectors and archaeologists.

## Acknowledgments

As always, our gratitude goes to Doug Leybourne for granting us permission to use the Alice Creswick drawings and to Greg Spurgeon for allowing us the use of North American Glass photos.

## Sources

### *American Glass Review*

1937 "Glass Factory Yearbook and Directory." *American Glass Review*, Pittsburgh, Pennsylvania.

### *American Glass Worker*

1885 "Trade Notes." *American Glass Worker* 1(9):2.

1886 "A New Bottle Factory." *American Glass Worker* 1(20):20.

### Ball, Frank Clayton

1937 *Memoirs of Frank Clayton Ball*. Privately printed, Muncie, Indiana.

### Birmingham, Frederic A.

1980 *Ball Corporation: The First Century*. Curtis Publishing, Indianapolis, Indiana.

### Brantley, William F.

1975 *A Collector's Guide to Ball Jars*. Martin, Muncie, Indiana.

### Creswick, Alice

1987a *The Fruit Jar Works, Vol. I, Listing Jars Made Circa 1820 to 1920's*. Douglas M. Leybourne, N. Muskegon, Michigan.

1987b *The Fruit Jar Works, Volume II, Listing Jars Made Circa 1900 to Modern*. Privately printed, Grand Rapids, Michigan.

Kath, Vivian

1997 "Granny Kath's Kitchen." *Antique Bottle & Glass Collector* 14(2):46-50.

Kepshire, Tom

2012 "Hoosier Slide." <http://www.monon.monon.org/bygone/hoosierslide.html>

Leybourne, Douglas M.

2008 *The Collector's Guide to Old Fruit Jars: Red Book 10*. Privately published, North Muskegon, Michigan.

Libby, E. D.

1906 E. D. Libby to Ball Bros. Glass Mfg. Co., December 22.

Lockhart, Bill and Barry Bernas

2014 "Turning Blue: Charles Blue and the Early Jar Machines." In *The Guide to Collecting Fruit Jars: Fruit Jar Annual 2014*, by Jerry McCann, pp. 19-47. Privately published.

Lockhart, Bill, Pete Schulz, Russell Hoenig, Phil Perry, Carol Serr, and Bill Lindsey

2010 "The Dating Game: The Owens Bottle Co." *Bottles and Extras* 21(1):50-62.

McCann, Jerry

2014 *The Guide to Collecting Fruit Jars: Fruit Jar Annual, Volume 18 – 2014*. Privately Published, Chicago.

*National Glass Budget*

1897 "Flint and Green Glass Review." *National Glass Budget* 13(26):4-6.

Okmulgee Historical Society and the Heritage Society of America

1985 *History of Okmulgee County, Oklahoma*. Historical Enterprises, Tulsa, Oklahoma.

Owens-Illinois Glass Co.

2001 "Consolidation of the United States Glass Container Industry." Spreadsheet, Owens-Illinois Glass Co.

Roller, Dick

1983 *Standard Fruit Jar Reference*. Acorn Press, Paris, Illinois.

1994 *Indiana Glass Factories Notes*. Acorn Press, Paris, Illinois.

1997 "Buffalo, N.Y. History Notes." Dick Roller files.

1999 "Muncie, IN History Notes." Dick Roller files.

2011 *Standard Fruit Jar Reference: 2011 Update*. Edited by Jerome McCann and Barry Bernas. Fruit Jar Annual/Phoenix Press, Chicago.

Scoville, Warren C.

1948 *Revolution in Glassmaking: Entrepreneurship and Technological Change in the American Industry, 1880-1920*. Harvard University Press, Cambridge, Massachusetts.

Smith, Michael David

1989 *Texas Glass: An Illustrated History of the Three Rivers Glass Company 1922-1937*. Atwood Printing, New Braunfels, Texas.

1996 "The Three Rivers Glass Company." *Bottles and Extras* 7(10):31-33.

Simpson, H.E.

1962 "The Glass Industry – 1961." *Glass Industry* 43(2):63-67.

Toulouse, Julian Harrison

1969 *Fruit Jars*. Thomas Nelson & Sons, Camden, New Jersey.

1971 *Bottle Makers and Their Marks*. Thomas Nelson, New York.

Wayne, Bruce

2010 "Ball Jars Collectors Website: Ball Corporation History."

[http://www.balljars.net/ball\\_corporation\\_history.htm](http://www.balljars.net/ball_corporation_history.htm)

Whitten, David

2013 “Glass Factory Marks on Bottles.”

<http://www.myinsulators.com/glass-factories/bottlemarks.html>