

AP Physics 1

Practice Test 1

SECTION I: MULTIPLE-CHOICE

Time: 90 minutes

50 questions

DIRECTIONS: Each of the questions or incomplete statements below is followed by four suggested answers or completions. Select the one (or two where indicated) that is best in each case. You have 90 minutes to complete this portion of the test. You may use a calculator and the information sheets provided in the appendix.

- Two objects are thrown vertically upward from the same initial height. One object has twice the initial velocity of the other. Neglecting any air resistance, the object with the greater initial velocity will rise to a maximum height that is
 - twice that of the other object, assuming they have the same mass
 - twice that of the other object, independent of their masses
 - four times that of the other object, assuming they have the same mass
 - four times that of the other object, independent of their masses
- A 2-kilogram cart has a velocity of 4 meters per second to the right. It collides with a 5-kilogram cart moving to the left at 1 meter per second. After the collision, the two carts stick together. Can the magnitude and the direction of the velocity of the two carts after the collision be determined from the given information?
 - No, since the collision is inelastic, we must know the energy lost.
 - Yes, the collision is elastic: 3/7 m/s left.
 - Yes, the collision is inelastic: 3/7 m/s right.
 - Yes, the speed is not 3/7 m/s.

3. Projectile X is launched at a 30-degree angle above the horizon with a speed of 100 m/s. Projectile Y is launched at a 60-degree angle with the same speed. Which of the following correctly compares the horizontal range and maximum altitude obtained by these two projectiles?

	Range	Altitude
(A)	X goes farther	X goes higher
(B)	Y goes farther	Y goes higher
(C)	X goes farther	Y goes higher
(D)	X and Y equal	Y goes higher

4. A 5 kg mass is sitting at rest on a horizontal surface. A horizontal force of 10 N will start the mass moving. What is the best statement about the coefficient and type of friction between the mass and the surface?
- (A) >0.20 static
 (B) <0.20 static
 (C) <0.20 kinetic
 (D) >0.20 kinetic
5. Which of the following graphs represents an object *moving* with no net force acting on it?

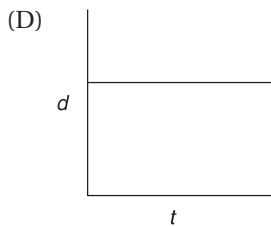
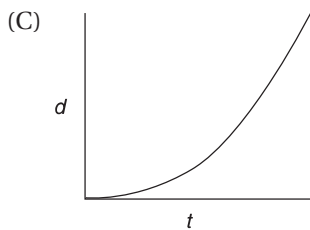
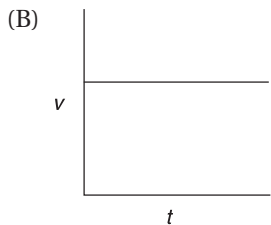
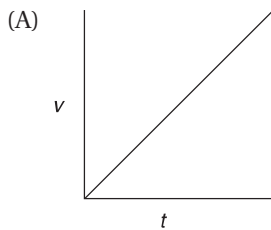

6. A projectile is launched horizontally with an initial velocity v_0 from a height h . If it is assumed that there is no air resistance, which of the following expressions represents the vertical position of the projectile? In other words, $y(x) = ?$
- (A) $h - gv_0^2/2x^2$
 - (B) $h - gv/2v_0^2$
 - (C) $h - gx^2/2v_0^2$
 - (D) $h - gx^2/v_0^2$

QUESTIONS 7 AND 8 ARE BASED ON THE INFORMATION AND DIAGRAM BELOW:

A 0.4-kilogram mass is oscillating on a spring that has a force constant of $k = 1,000$ newtons per meter.

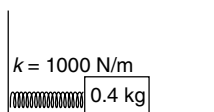

7. Which of the following measurements would allow you to determine the maximum velocity experienced by the mass?
- (A) No additional information is required.
 - (B) Minimum velocity
 - (C) Maximum acceleration
 - (D) None of these would allow you to determine maximum velocity.
8. Which of the following statements concerning the oscillatory motion described above is correct? (All statements refer to magnitudes.)
- (A) The maximum velocity and maximum acceleration occur at the same time.
 - (B) The maximum velocity occurs when the acceleration is a minimum.
 - (C) The velocity is always directly proportional to the displacement.
 - (D) The maximum velocity occurs when the displacement is a maximum.
9. A bullet of known mass (m_1) is fired vertically into an initially stationary wood block of known mass (m_2). The resulting wood + bullet combined system is then measured to rise to a maximum height of h . Can the initial speed of the bullet be calculated from this information?
- (A) Yes. Solve $(m_1 + m_2)gh = \frac{1}{2}(m_1)v^2$.
 - (B) Yes. Solve the momentum conservation of collision first and the energy conservation of the rising combination second.
 - (C) No. We don't know if momentum is conserved during this collision.
 - (D) No. We don't know enough details about the mechanical energy lost during the collision.
10. A 10 kg mass is being pulled horizontally by a constant force along a rough surface ($\mu_k = 0.1$) at constant velocity. Which of the following is the best statement regarding the constant force?
- (A) = 10 N
 - (B) > 10 N
 - (C) < 10 N
 - (D) > 1 N

11. A 10-newton force is applied to two masses, 4 kilograms and 1 kilogram, respectively, that are in contact as shown below. The horizontal motion is along a frictionless plane. What is the magnitude of the contact force, P , between the two masses?

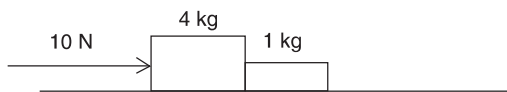

- (A) 10 N
 (B) 8 N
 (C) 6 N
 (D) 2 N
12. An object with mass m is dropped from height h above the ground. While neglecting air resistance, which formula best describes the power generated if the object takes time t to fall?
- (A) mgh
 (B) $mght$
 (C) $mg^2t/2$
 (D) mgh/t
13. A 1,500-kilogram car has a velocity of 25 meters per second. If it is brought to a stop by a nonconstant force in 10 to 15 seconds, can the magnitude of the impulse applied be determined?
- (A) Yes, it is 37,500 N · s.
 (B) No, you need to know the details about the nonconstant force.
 (C) No, you must know the exact duration of the impulse.
 (D) No, you must know the average force during and the duration of the impulse.
14. A block of mass M rests on a rough incline, as shown below. The angle of elevation of the incline is increased until an angle of θ is reached. At that angle, the mass begins to slide down the incline. Which of the following is an expression for the coefficient of static friction μ ?

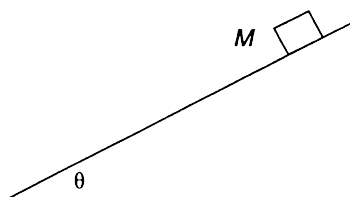

- (A) $\tan \theta$
 (B) $\sin \theta$
 (C) $\cos \theta$
 (D) $1/(\cos \theta)$

15. A pendulum of a given length swings back and forth a certain number of times per second. If the pendulum now swings back and forth the same number of times but in twice the time, the length of the pendulum should be
- (A) doubled
 - (B) quartered
 - (C) quadrupled
 - (D) halved
16. This graph of force versus time shows how the force acts on an object of mass m for a total time of T seconds. If the mass begins at rest, which is the correct method to find the final speed of the mass?

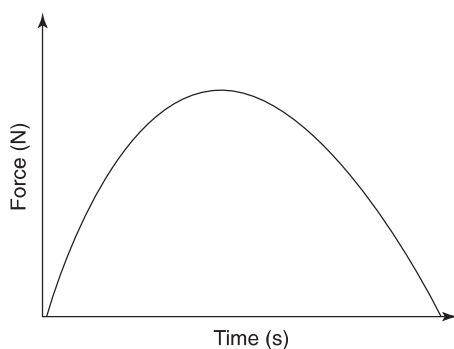

- (A) Average value of this graph times total time divided by mass
 - (B) Area under this graph divided by mass
 - (C) Since the final force is zero, the object is at rest after time T
 - (D) Average slope of this graph divided by mass
17. A child of unknown mass is on a swing of unknown length that varies in height from 75 cm at its lowest height above the ground to a maximum height of 225 cm above the ground. Is there enough information to find speed of the swing at its lowest point?
- (A) No, the child's mass must be known.
 - (B) No, the length of the swing must be known to determine the centripetal acceleration.
 - (C) Yes, it is 5.5 m/s.
 - (D) Yes, it is 4 m/s.
18. The gravitational force of attraction between two identical masses is 36 N when the masses are separated by a distance of 3 m. If the distance between them is reduced to 1 m, which of the following is true about the net gravitational field strength due to both masses being at the halfway point?
- (A) It is 9 times stronger total.
 - (B) Not enough information is given to determine net gravitational field strength.
 - (C) Each mass's gravitation is 9 times stronger, so the net gravitational field strength is 18 times stronger.
 - (D) It is zero.

19. A 200-kilogram cart rests on top of a frictionless hill as shown below. Can the impulse required to stop the cart when it is at the top of the 10-meter hill be calculated?

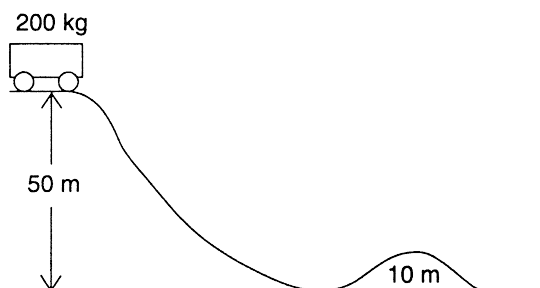

- (A) No, more information about friction is required.
 (B) No, more information about the impulse is required.
 (C) Yes, calculate the velocity from free-fall kinematics and use this velocity in the change in momentum equation.
 (D) Yes, calculate the speed from energy conservation and use this speed in the change in momentum equation.
20. An object of mass m starts at a height of H_1 with a speed of v_1 . A few minutes later, it is at a height of H_2 and a speed v_2 . Which of the following expressions best represents the work done to the mass by nongravitational forces to the object during this time?
- (A) $mg(H_2 - H_1) + \frac{1}{2}m(v_2^2 - v_1^2)$
 (B) $mg(H_2 - H_1) - \frac{1}{2}m(v_2^2 - v_1^2)$
 (C) $\frac{1}{2}m(v_2^2 - v_1^2)$
 (D) $\frac{1}{2}m(v_1^2 - v_2^2)$
21. An object with 0.2 kg mass is pushed down vertically onto an elastic spring ($k = 20 \text{ N/m}$). The spring is compressed by 20 cm and then released such that the object will fly off. Which of the following will have the largest effect on increasing the maximum height the object will fly? (Assume no air resistance.)
- (A) Halving the mass
 (B) Doubling the compression distance
 (C) Using a spring with a spring constant twice as big
 (D) Doing the same experiment on a different planet with half the gravitational field strength

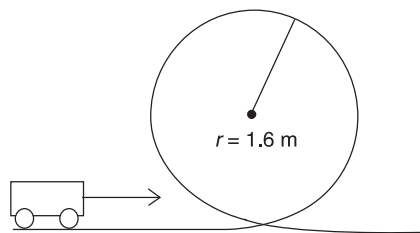

22. A cart with a mass of m needs to complete a loop-the-loop of radius r , as shown above. What is the approximate minimum velocity required to achieve this goal?

- (A) $(gr)^{1/2}$
- (B) $(5gr)^{1/2}$
- (C) $2(gr)^{1/2}$
- (D) $(2gr)^{1/2}$

QUESTIONS 23–25 ARE BASED ON THE FOLLOWING CIRCUIT:

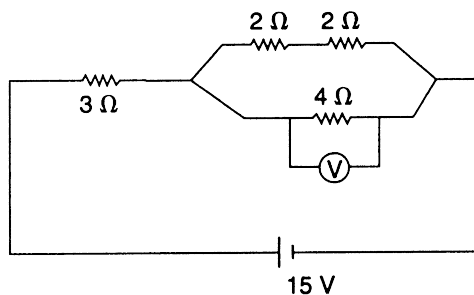

23. What is the equivalent resistance of the circuit?

- (A) 6Ω
- (B) 8Ω
- (C) 11Ω
- (D) 5Ω

24. What is the reading of the voltmeter across the 4-ohm resistor?

- (A) 3 V
- (B) 9 V
- (C) 12 V
- (D) 6 V

25. What is the current through the leftmost 2-ohm resistor?

- (A) 3 A
- (B) 1.5 A
- (C) 0.75 A
- (D) 1 A

26. A wire segment in a circuit with a cross-sectional area of A and length L is replaced by a wire segment made of the same material that has twice the area but half the length. The resistance of the new segment, compared to the original segment, will
- (A) be reduced by half
 - (B) be reduced to one-quarter
 - (C) quadruple
 - (D) remain the same
27. In the fixed standing wave shown below (imagine a string of fixed length), what will happen to the wavelength and frequency if the wave speed is raised while the standing wave pictured remains unchanged?

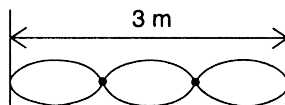

- (A) Wavelength increases while frequency remains the same.
 - (B) Wavelength remains the same while frequency increases.
 - (C) Both wavelength and frequency increase.
 - (D) Although we know the product of wavelength and frequency increases, we do not know what combination is producing this effect.
28. Bats can find objects in the dark by using echolocation (sending out a high-frequency sound and listening to the echo). They also listen for a change in the pitch of the echo to
- (A) confirm the estimated distance of the object
 - (B) determine the velocity of the object
 - (C) determine whether the object is moving toward or away from them
 - (D) estimate the approximate composition of the object

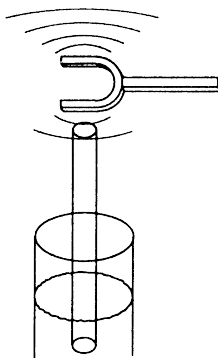

29. A 340-hertz tuning fork sets an air column vibrating in fundamental resonance, as shown above. A hollow tube is inserted into a column of water, and the height of the tube is adjusted until strong resonance is heard. At approximately what length of the air column will this happen?
- (A) 100 cm
 - (B) 75 cm
 - (C) 50 cm
 - (D) 25 cm

30. How many different directions can a two-dimensional vector have if its components are of equal magnitude?
- (A) One, at 45°
 - (B) Two
 - (C) Four
 - (D) Infinite
31. Two vectors, **A** and **B**, have components $A_x = -2$, $A_y = 3$, $B_x = 5$, and $B_y = 1$. What is the approximate magnitude of the vector **A + B**?
- (A) 3
 - (B) 4
 - (C) 5
 - (D) 7
32. As the angle between two vectors increases from 0° to 180° , the magnitude of their resultant
- (A) increases, only
 - (B) increases and then decreases
 - (C) decreases, only
 - (D) decreases and then increases
33. At what angle should a projectile be launched in order to achieve the maximum range for a given initial velocity under no air resistance?
- (A) 90°
 - (B) 30°
 - (C) 45°
 - (D) 60°
34. An object is dropped from a height of 45 m. Neglecting air resistance, what is the approximate velocity of the object as it hits the ground?
- (A) 10 m/s
 - (B) 15 m/s
 - (C) 20 m/s
 - (D) 30 m/s
35. A boat moving due north crosses a river 240 meters wide with a velocity of 8 meters per second relative to the water. The river flows east with a velocity of 6 meters per second. How far downstream will the boat be when it has crossed the river?
- (A) 240 m
 - (B) 180 m
 - (C) 420 m
 - (D) 300 m

QUESTIONS 36 AND 37 ARE BASED ON THE FOLLOWING INFORMATION:

A variable force acts on a 2-kilogram mass according to the graph below.

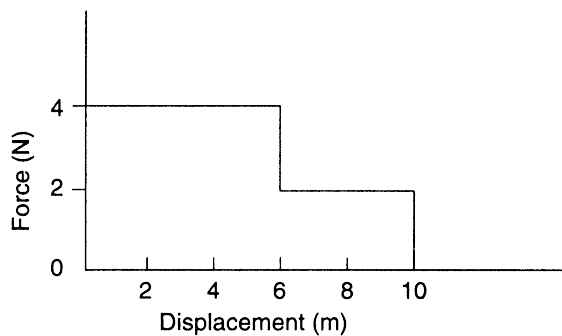

36. How much work was done while displacing the mass 10 meters?
- (A) 40 J
(B) 38 J
(C) 32 J
(D) 30 J
37. What was the average force supplied to the mass for the entire 10-meter displacement?
- (A) 3.2 N
(B) 1.2 N
(C) 4.4 N
(D) 4 N
38. A man weighing himself is standing on a bathroom scale in an elevator that is accelerating upward at a rate of 0.5 meter per second squared. By what percentage is the reading of the scale off from the person's true weight?
- (A) 0% (accurate)
(B) 5% too high
(C) 5% too low
(D) 0.5% too high
39. A 50-kilogram person is sitting on a seesaw 1.2 meters from the balance point. On the other side, a 70-kilogram person is balanced. How far from the balance point is the second person sitting?

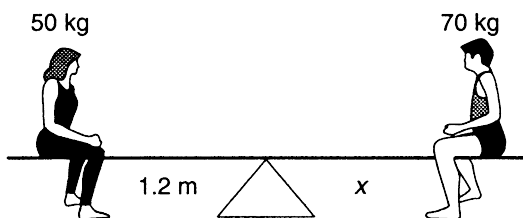

- (A) 0.57 m
(B) 0.75 m
(C) 0.63 m
(D) 0.86 m

40. An object rolls down a steep incline with very little friction. At the same time, an object of equal mass slides down the same incline. Which one takes less time to get to the bottom?
- (A) They take the same time.
 - (B) The rolling object takes less time.
 - (C) The sliding object takes less time.
 - (D) The answer depends on the rolling object's moment of inertia.
41. What is the value of g at a position above Earth's surface equal to Earth's radius?
- (A) 9.8 N/kg
 - (B) 4.9 N/kg
 - (C) 2.45 N/kg
 - (D) 1.6 N/kg
42. If it takes 5 N to move 2 C of charge in a constant electric field, how much energy is needed to move 3 C of charge 40 cm in the same field?
- (A) 2.5 J
 - (B) 7.5 J
 - (C) 2.0 J
 - (D) 3.0 J
43. If an object is spinning at 150 RPM (revolutions per minute) and comes to stop in 2 seconds, what is its average acceleration in radians/s²?
- (A) -2.5π
 - (B) -2π
 - (C) -5π
 - (D) -10π
44. What is the work done by a horizontal spring (spring constant k) expanding from a compression distance x to an extension distance x to an attached mass?
- (A) $2kx^2$
 - (B) $\frac{1}{2}kx^2$
 - (C) kx^2
 - (D) 0
45. If an isolated spinning object's moment of inertia is reduced by a factor of 3 by internal forces, how will its angular momentum change?
- (A) Angular momentum will be 3 times its previous value.
 - (B) Angular momentum will be reduced to 1/3 its previous value.
 - (C) Angular momentum will be reduced to 1/9 its previous value.
 - (D) Angular momentum will remain unchanged.
46. If the tension in a taut string is increased, which of the following will also be increased when the fundamental frequency is struck? Select two answers.
- (A) The velocity of propagation
 - (B) The frequency of the fundamental
 - (C) The wavelength of the fundamental
 - (D) The amplitude of the wave

47. A friend is balancing a fork on one finger. Which of the following are correct explanations of how he accomplishes this? Select two answers.
- (A) Total energy is conserved.
 - (B) The fork's moment of inertia is zero.
 - (C) The fork's center of mass is above his finger.
 - (D) The fork's clockwise torque is equal to its counterclockwise torque.
48. Two tuning forks are struck at the same time. A beat frequency of 12 beats per second is observed. If one tuning fork has a frequency of 384 Hz, what could be the frequency of the second tuning fork? Select two answers.
- (A) 260 Hz
 - (B) 372 Hz
 - (C) 396 Hz
 - (D) 408 Hz
49. A book rests on top of a table. Which of the following are an action-reaction pair described by Newton's third? Select two answers.
- (A) The weight of the book and the normal force of the table up on the book
 - (B) The weight of the book and the weight of the table
 - (C) The weight of the table and the upward pull of the table on Earth
 - (D) The normal force up on the book from the table and the downward force on the table due to the book
50. Consider the impulse received by the first car in each of the following cases. In each case, the cars are at rest after the collision. In which two of the following cases will the car receive the same impulse? Select two answers.
- (A) A 5,000 kg car traveling at 10 m/s has a head-on collision with an equal and oppositely directed second car.
 - (B) A 5,000 kg car traveling at 10 m/s has a head-on collision with a large building.
 - (C) A 2,500 kg car traveling at 10 m/s has a head-on collision with an equal and oppositely directed second car.
 - (D) A 2,500 kg car traveling at 5 m/s has a head-on collision with an equal and oppositely directed second car.

SECTION II: FREE-RESPONSE

Time: 90 minutes
5 questions

DIRECTIONS: You have 90 minutes to complete this portion of the test. You may use a calculator and the information sheets provided in the appendix.

1. A group of students are given the following supplies: a stopwatch, a long string, various metersticks and protractors, and a large supply of various styles of predetermined masses.
 - (a) Describe three short experimental procedures to determine the dependency of a simple pendulum’s period of oscillation on amplitude, mass, and length. You may include a labeled diagram of your setup to help in your description. Indicate what measurements you would take and how you would take them. Include enough detail so that another student could carry out your procedure.
 - (b) What are the expected results of each investigation? Sketch out what the data will look like in each of the three investigations (amplitude, mass, and length).
 - (c) What are the common sources of error or expected deviations from ideal results that might happen during this investigation? Which of the three investigations might you expect to deviate the most from the ideal results and why?
 - (d) Here are some raw data taken from the length vs. period investigation by a student who suspects there is a correlation between the two. Determine which variables to graph to produce a linear function. Graph this new data below, and interpret the slope of your best fit-line.

Length (cm)	Period (s)	?
10	0.62	
20	0.90	
30	1.09	
40	1.28	
55	1.48	
75	1.75	
85	1.85	

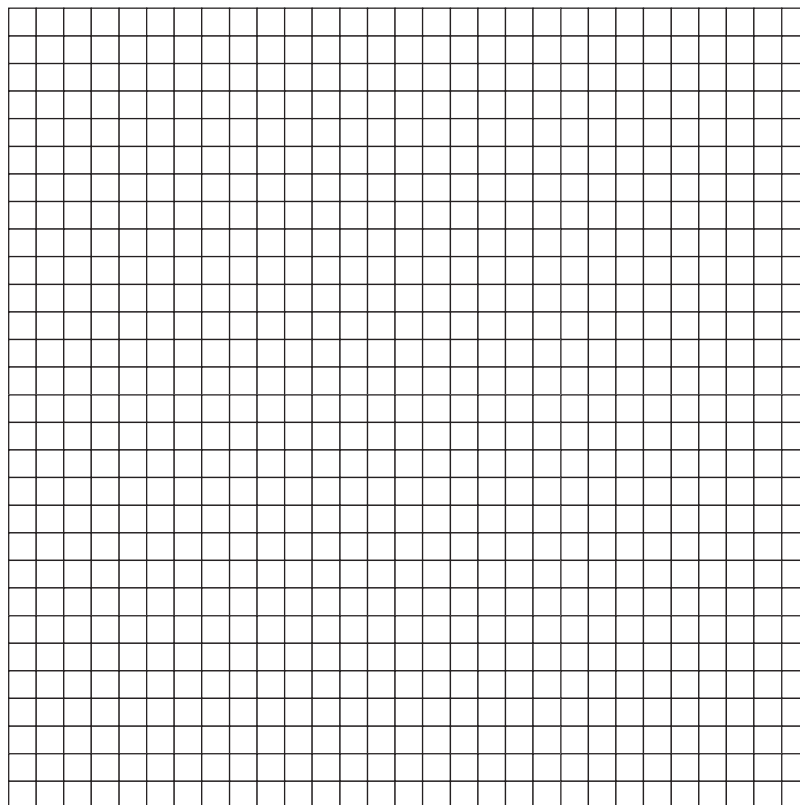

2. A mass m is resting at a height h above the ground. When released, the mass can slide down a frictionless track to a loop-the-loop of radius R as shown below.

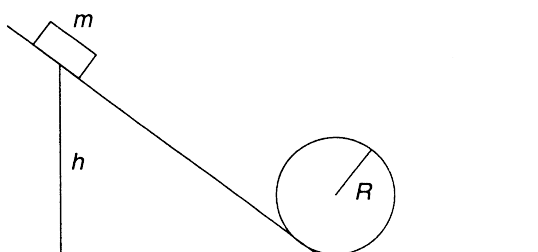

- (a) As the mass slides down the incline, it gains speed. However, the mass may or may not “make it” around the loop without falling out. Why and under what conditions will the mass travel around the loop without falling out? Why and under what conditions will it not complete the loop? Explain your reasoning qualitatively, making sure you address the normal force experienced by the mass.
- (b) Two fellow students are arguing about whether the maximum possible R of a loop that the mass can make it around will be linearly dependent on height h or if the relationship will be some power law. Without solving for the relationship explicitly, indicate a line of reasoning that would settle this argument.
- (c) Within the loop, the normal force is always acting in a centripetal direction. Explain why the normal force is not always equal to mv^2/R at each point. Are there any points along the loop where the normal force is equal to mv^2/R ? Support your argument with free-body diagrams.

(d) If the minimum height h has been found for a fixed loop of size R but a rolling ball of mass m is substituted for the sliding mass, the ball will (indicate your choice):

- _____ make it through the loop more easily
- _____ pass through the loop the same as before
- _____ fall out of the loop

Justify your answer qualitatively, with no equations or calculations.

3. Use the sketch to answer the following questions

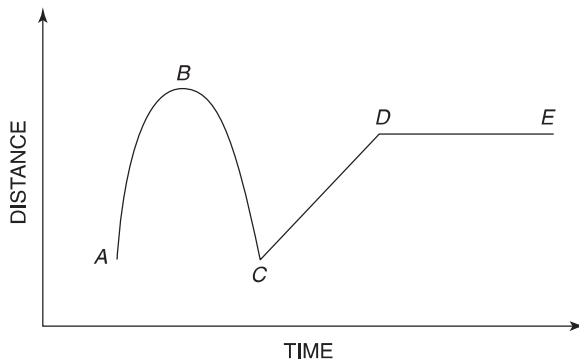

(a) Use the qualitative keywords below to fill in the chart beneath with a brief description of the motion:

List 1: constant, increasing, decreasing

List 2: negative, positive, zero

Time Interval	Velocity (One Word From List 2)	Speed (One Word From List 1)	Acceleration (One Word From List 2)
$A \rightarrow B$			
$B \rightarrow C$			
$C \rightarrow D$			
$D \rightarrow E$			

(b) Which is faster, the average velocity from C to D or the average velocity from C to E ? Explain your reasoning.

(c) What is the instantaneous velocity at point B ? Explain your reasoning.

(d) Pick a couple of points on this graph that are not a realistic representation of a real-world object's motion. Explain what is problematic about these two points.

(e) Sketch a velocity versus time graph from this data. Label points A , B , C , D , and E .

4. A 2-kilogram mass is twirled in a vertical circle as shown. It is attached to a 2-meter rope. As the mass just clears the ground (point A), its velocity is 10 m/s to the right. Neglect any air resistance. When the mass reaches point B , it makes a 30-degree angle to the horizontal as shown.

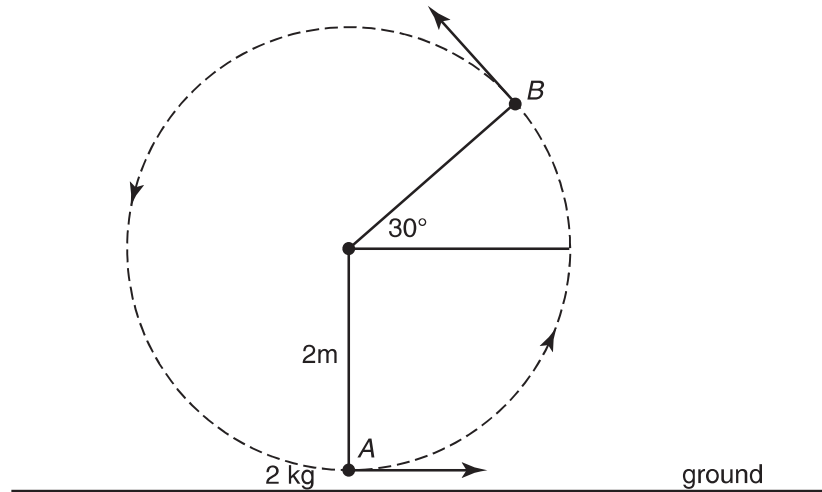

- (a) Describe qualitatively, using words and diagrams, the difference in the object's speed at point B if the twirling is done (i) at constant speed or (ii) at constant tension. Which would result in the greater speed at point B ? Include an analysis of how the tension must change in part (i).
- (b) At point B , the rope is released and the mass becomes a projectile. Assuming the rope has a uniform distribution of mass and remains attached to the flying object. Which of the following options best describe the projectile's range as compared with a launch without the rope?
- ___ addition of rope makes no difference to the range
- ___ addition of rope increases the range
- ___ addition of rope decreases the range
- Explain your reasoning.
- (c) When twirling the object at constant speed, explain in terms of work and energy, how the constant speed is maintained. Is the path truly circular when the object's speed is maintained? In your explanation, be explicit about which forces are doing positive work and which are doing negative work.

5. You are given three 2-ohm resistors, some wire, a variable DC voltage supply, a voltmeter, and an ammeter.
- (a) Draw a schematic diagram of a circuit that will produce an equivalent resistance of 3 ohms as well as measure the circuit current and source voltage.
 - (b) Which, if any, of these components are assumed to have zero internal resistance? Which, if any, of these components are assumed to have infinite resistance? Justify your choices.
 - (c) Trace out one complete loop in your circuit, and prove Kirchoff's loop rule. Once you set up your rule, assume a setting of 6 volts on the power supply. Verify your rule numerically.
 - (d) A student wishes to measure the voltage and current in a simple circuit using small lightbulbs instead of commercially manufactured resistors. She finds that after a short while, the current in the ammeter is decreasing. How might she account for this?