

**DAYANANDA SAGAR COLLEGE OF ENGINEERING**  
**DEPARTMENT OF ELECTRICAL & ELECTRONICS ENGINEERING,**  
**BENGALURU-78**

**Subject code:15ELE15**

**Subject: Basic Electrical Engineering**

**MODULE1(A)**

**D.C CIRCUITS**

**Introduction:**

- i. **Potential Difference (PD):** The ability of a charged particle to do the work is called electric potential. The difference b/w electric potentials at any two given points in a circuit is known as potential difference.

Electric Potential (V) = Workdone/charge

Unit is Volt.

- ii. **Current:** Is defined as rate of flow of charge in an electric circuit. Its unit is Ampere.

Current (I)= dq/dt

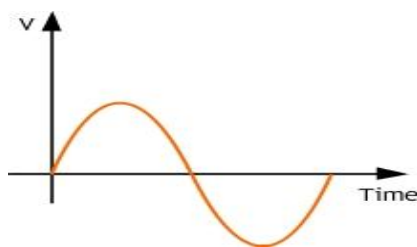

*Fig:1.1.1(a).AC supply*



*Fig:1.1.(b)DC supply*

*[Ref: DSI ppt]*

- iii. **Power:** Rate of doing the work is known as power. Its unit is Watt.

$$P = V \cdot I$$

iv. **Energy:** Work done in transferring a charge through an element is known as energy. Unit is Joule.

v. **Resistance:** The property of an electric current opposing the flow of current and causes electrical energy to be converted to heat is called resistance. Unit is ohm

$$R = V/I$$

### Ohm's Law:

When voltage is applied across a conductor, current flows through it. A definite relationship exists between current, applied voltage and resistance of the conductor.

If 'I' is the current flowing through a conductor of resistance R, across which a potential difference V is applied, then according to Ohm's Law.

$$I \propto V \text{ or } I = V/R \text{ or } V = IR$$

where V is in volts, R is in Ohms and I is in amperes.

Ohm's Law may be stated as follows

**The physical state** i.e. temperature remaining constant, the current flowing through a conductor is directly proportional to the potential difference applied across its ends.

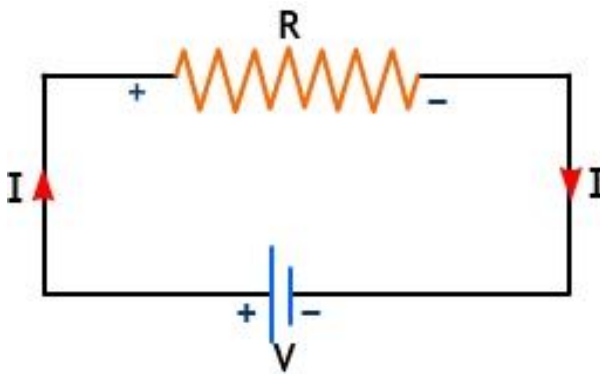

Fig:1.1.1. Ohm's Law[Ref:DSI ppt]

i) **Kirchoff's Current Law (KCL):** In any electrical network the algebraic sum of all currents meeting at a point is zero or the sum of incoming currents towards any point is equal to the sum

of outgoing currents away from that point. For example four conductors are meeting at a point O, carrying currents  $I_1$ ,  $I_2$ ,  $I_3$  and  $I_4$  as shown in figure.

Convention :-

Current flowing inward  $\rightarrow$  +ve

Current flowing away from O  $\rightarrow$  -ve

Sign convention:- +  $\rightarrow$  current towards point O

-  $\rightarrow$  current away point O

Applying KCL to point O, the algebraic sum of currents at that point, will be zero.

$$\text{i.e., } (I_1) + (I_2) + (-I_3) + (-I_4) = 0$$

$$\text{or } I_1 + I_2 = I_3 + I_4$$

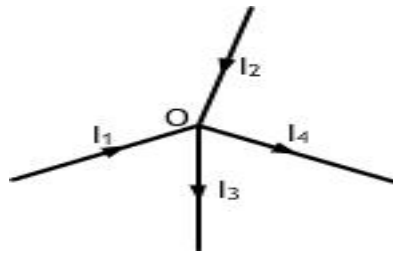

*Fig:1.1.2. Kirchoff's current law[Ref: DSIppt]*

**ii) Kirchoff's Voltage Law (KVL):** In any closed circuit or mesh, the algebraic sum of products of currents and resistances (voltage drops) plus the algebraic sum of all the emf's in that circuit is zero, i.e. algebraic sum of emf's + algebraic sum of voltage drops = 0

- a) **Signs of emf's:** A rise in potential should be taken as positive and a fall in potential should be taken as negative. Consider from the negative terminal of a battery or source towards the positive terminal, there is a rise in potential and it must be considered positive and from the positive terminal of a battery or voltage source to the negative terminal, there is a fall in potential which should be taken as negative.

- b) **Signs of voltage drops:** When current passes through a resistance there is a voltage drop in it. With the current, the voltage drop should be considered to be negative as the current flows from higher potential to lower potential (fall in potential). and against the current flow, the voltage drop should be considered as positive (rise in potential)

**Series Circuit:**

The circuit in which resistances are connected end-to-end, so that there is only one path for current flow, is called a series circuit.

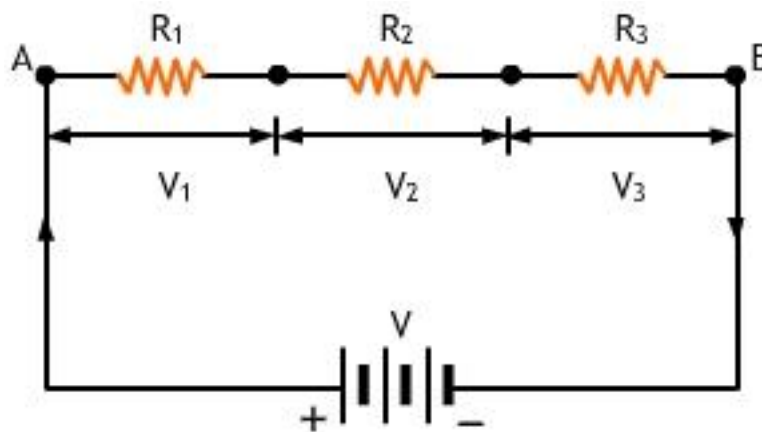

Fig: 1.1.3.Series circuit[Ref: DSI ppt]

Figure shows a circuit, where resistors,  $R_1$ ,  $R_2$  and  $R_3$  are connected in series, and a voltage of  $V$  volts is applied at the extreme ends  $A$  and  $B$ , to cause a current of  $I$  amperes to flow through all these resistors.

**Analysis of Series Circuit:**

- i. The same current flows through all the resistances.
- ii. There will be a voltage drop across each resistance. The sum of the voltage drops is equal to the applied voltage.
- iii. Total Power dissipated by the circuit is equal to the sum of the power dissipated by each resistor.

Let  $V_1$ ,  $V_2$  and  $V_3$  be the voltage drops across  $R_1$ ,  $R_2$  and  $R_3$  respectively.

Now,  $V = V_1 + V_2 + V_3$

$$= IR_1 + IR_2 + IR_3 = I (R_1 + R_2 + R_3) \dots\dots\dots(\text{using ohm's law})$$

$$V/I = R_1 + R_2 + R_3$$

According to ohm's law,  $V/I$  is the total circuit resistance  $R$ .

Therefore,

$$R = R_1 + R_2 + R_3$$

i.e., Total resistance = sum of individual resistances.

Thus, when a number of resistors are connected in series, the equivalent resistance (total circuit resistance) is given by the arithmetic sum of their individual resistances.

**Parallel Circuit:**

When a number of resistors are connected in such a way that one end of each of them is joined to a common point, and the other end of each of them is joined to another common point, then the resistors are said to be connected in parallel and such circuits are known as parallel circuits.

Let  $I_1$ ,  $I_2$  and  $I_3$  be the currents in resistors  $R_1$ ,  $R_2$  and  $R_3$  respectively.

Now,  $I = I_1 + I_2 + I_3$

$$= V/R_1 + V/R_2 + V/R_3 = V \{1/R_1 + 1/R_2 + 1/R_3\}$$

$$\therefore I/V = 1/R_1 + 1/R_2 + 1/R_3$$

By Ohm's Law,  $V/I = R$ ,

$$\therefore 1/R = 1/R_1 + 1/R_2 + 1/R_3$$

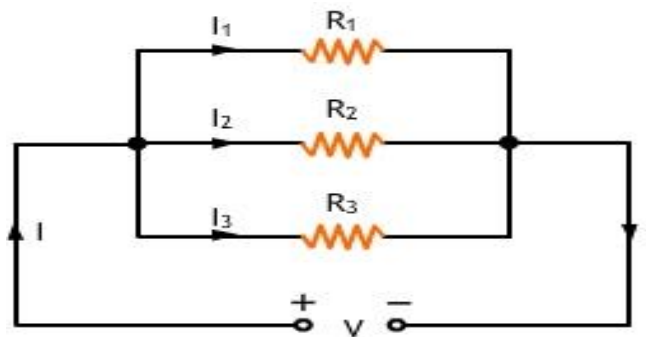

Fig:1.1.4. Parallel circuit [Ref: DSI ppt]

**Analysis of Parallel Circuit:**

- i. The same voltage appears across all the resistances.
- ii. The current is distributed in each resistance. The sum of the branch current is equal to the applied current.
- iii. Total Power dissipated by the circuit is equal to the sum of the power dissipated by each resistor.

**Problems:**

1. A resistor of  $12\ \Omega$  is connected in series with a combination of  $15\ \Omega$  and  $20\ \Omega$  resistors in parallel. A voltage of  $120\ \text{V}$  is applied across the whole circuit. Find (i) Current taken from the supply. (ii) Voltage across the  $12\ \Omega$  resistor.

**Solution:**

- i) Net resistance of the parallel branch AB is

$$R_{AB} = 15 \times 20 / (15 + 20) = 300 / 35 = 8.57\ \Omega$$

Series resistance  $R_{BC} = 12\ \Omega$

Therefore, total circuit resistance =  $12 + 8.57 = 20.57\ \Omega$

Current drawn from the supply

$$I = 120 / 20.57 = 5.83\ \text{A}$$

- ii) Voltage across  $12\ \Omega$  resistor,

$$V_{BC} = R_{BC} \times I = 12 \times 5.83 = 70\ \text{V}.$$

(2) If the total power dissipated in the network shown in figure is 16 watts, find the value of R and the total current?

**Solution:**

Given :  $V = 8\ \text{volts}$

Total power dissipated,  $P = 16$  watts

Power,  $P = V^2 / R_{eq}$

Where  $R_{eq}$  = combined or equivalent resistance of the circuit.

Therefore,  $16 = 8^2 / R_{eq}$  or  $R_{eq} = 4 \Omega$

Also  $R_{eq} = [4R / (4 + R)] + [(8 \times 2)/(8 + 2)]$

3. Find the current in all branches of the network shown in figure.

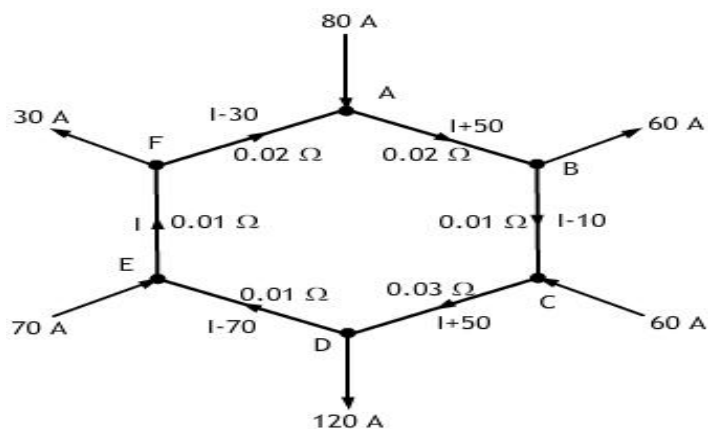

**Solution:**

The various branch currents are:

Branch AB:  $I + 50 = -11 + 50 = 39$  Amps from A to B

Branch BC:  $I - 10 = -11 - 10 = -21$  Amps or 21 Amp from C to B

Branch CD:  $I + 50 = -11 + 50 = 39$  Amps from C to D

Branch DE:  $I - 70 = -11 - 70 = -81$  Amps or 81 Amps from E to D

Branch EF:  $I = -11$  Amps or 11 Amps from F to E

Branch FA:  $I - 30 = -11 - 30 = -41$  Amps or 41 Amps from A to F

4. What is the difference of potential between the points X and Y in the network shown?

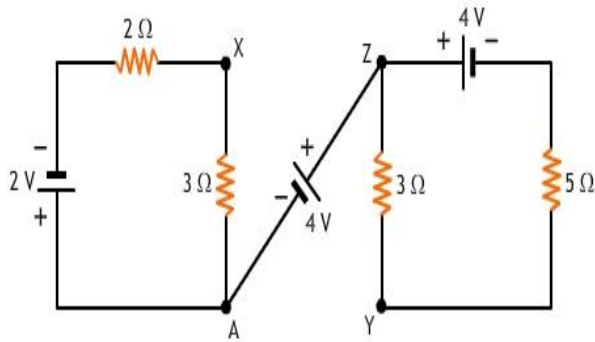

**Solution:** Consider the loop including AX

Total resistance =  $2 + 3 = 5$  ohms.

Current through AX =  $2/5 = 0.4$  A (from A to X)

Drop across 3 ohms resistor =  $0.4 \times 3 = 1.2$  V

Consider the other loop

Total resistance =  $5 + 3 = 8$  ohms.

Current through ZY =  $4/8 = 0.5$  A. (from Z to Y) .

Drop across 3 ohms resistor =  $0.5 \times 3 = 1.5$  V

Drop between X and Y is = drop across 3 ohms (XA) + drop across AZ + drop across 3 ohms (ZY)

$$1.2 + 4 - 1.5 = 3.7 \text{ V}$$

5. Find the current flowing through the galvanometer G in the Wheatstone bridge network shown below.



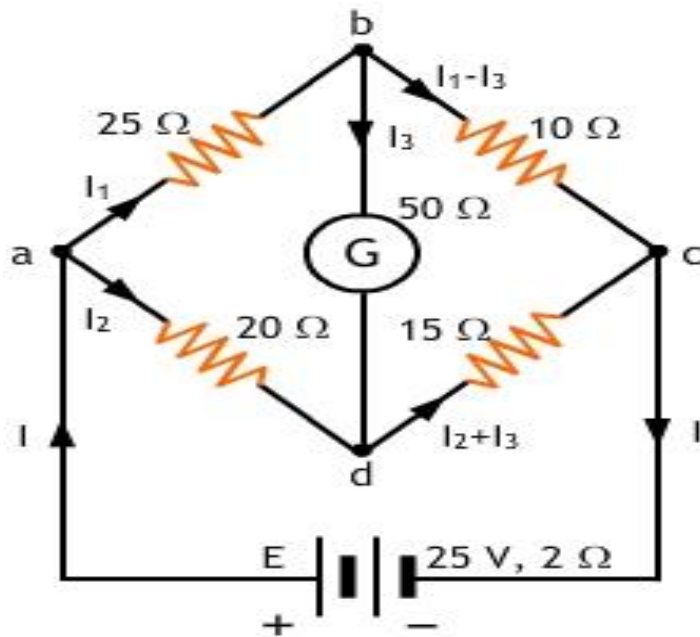

**Solution:**

Consider the loop abda

$$\begin{aligned}
 -25I_1 - 50I_3 + 20I_2 &= 0 \\
 -5I_1 - 10I_3 + 4I_2 &= 0 \quad \text{-----(i)}
 \end{aligned}$$

Consider the loop bcd

$$\begin{aligned}
 -10(I_1 - I_3) + 15(I_2 + I_3) + 50I_3 &= 0 \\
 -2I_1 + 3I_2 + 15I_3 &= 0 \quad \text{-----(ii) (divided by 5)}
 \end{aligned}$$

Consider the loop adcEa

$$-20I_2 - 15(I_2 + I_3) - 2I + 25 = 0$$

But  $I = I_1 + I_2$

Substituting this value in the above equation

$$\begin{aligned}
 -20I_2 - 15(I_2 + I_3) - 2(I_1 + I_2) + 25 &= 0 \\
 -2I_1 - 37I_2 - 15I_3 + 25 &= 0 \quad \text{-----(iii)}
 \end{aligned}$$

6. Two storage batteries A and B are connected in parallel to supply a load of 0.30 ohm. The open circuit e.m.f. of A is 11.7 V and that of B is 12.3 V. The internal resistance are 0.06 ohm and 0.05 ohm respectively. Find the current supplied to the load.

**Solution:**

Let the currents supplied by the batteries be  $I_1$  and  $I_2$  respectively.

Current through load,  $I = I_1 + I_2$

Applying Kirchoff's second law to loops ABCDA and FBCGF we have

$$0.06I_1 - 0.05I_2 + 11.7 - 12.3 = 0$$

$$\text{or } 0.06I_1 - 0.05I_2 = 11.7 - 12.3$$

$$\text{or } 0.06I_1 - 0.05I_2 = -0.6 \quad \text{-----(i)}$$

$$-0.06I_1 - 0.3(I_1 + I_2) + 11.7 = 0$$

$$\text{or } 0.36I_1 + 0.3I_2 = 11.7 \quad \text{-----(ii)}$$

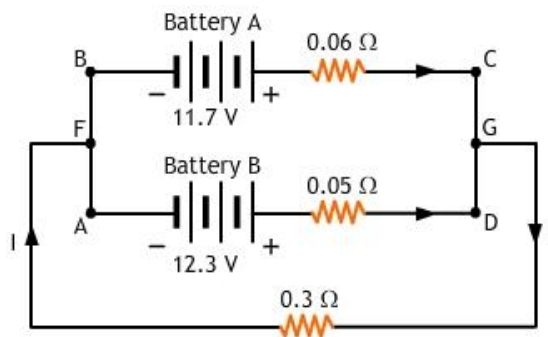

Multiplying expression (i) by 6, we get

$$0.36I_1 - 0.3I_2 = -3.6 \quad \text{-----(iii)}$$

Subtracting expression (iii) from expression (ii), we get

$$0.6I_2 = 15.3$$

or  $I_2 = 25.5$  Amps

Substituting the value of  $I_2$  in eqn (i), we get

$$0.06I_1 - (0.05 \times 25.5) = -0.6$$

$$\text{or } 0.06I_1 = 1.275 - 0.6 = 0.675$$

$$\therefore I_1 = 11.25 \text{ Amps}$$

Current through the load of 0.3 ohm

$$I = I_1 + I_2 = 11.25 + 25.50 = 36.75 \text{ Amps.}$$

MODULE(1B)

**MAGNETIC CIRCUIT**

**Magnetic Circuit**

The magnetic circuit is the closed path described by the magnetic flux.

Consider an iron ring in which magnetic flux is produced due to which current flowing through the coil and its circuit having length ' $l$ ' metres which is shown in figure 1 below.

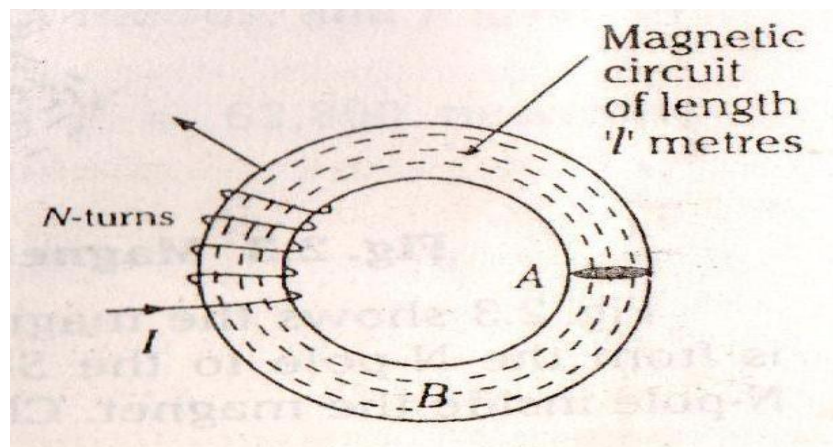

*Fig:1.2.1. Magnetic Circuit*

**Important Definitions:**

1. **Magnetic Field:** The space or surrounding region of a magnet in which magnetic effect is felt is called as magnetic field. Consider a bar magnet. The magnetic field of magnet is represented by imaginary lines around it and is known as magnetic lines of forces. And their direction always starts from north to south pole.

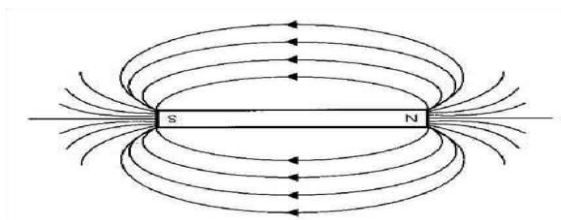

*Fig:1.2.2. Magnetic Field*

2. **Magnetic Flux:** The total number of magnetic lines of force in a magnetic field is called flux and its notation is represented by Greek Letter  $\phi$ (phi) and its unit is weber (Wb).

3. **Magnetic Flux Density:** It is defined as the number of lines per unit area. Its notation is B

$$\text{Flux density } B = \phi/A \text{ Wb/m}^2$$

where  $\phi$  is the flux and A is the area of cross section and its unit is weber per square meter or Tesla.

4. **Magnetomotive Force or M.M.F:** M.M.F is defined as the magnetic force, which creates magnetic flux in a magnetic material. The unit is ampere turns (AT).

$$\text{M.M.F} = N I$$

Where, N = Number of turns in the coil

I = Current through the coil

Or  $\text{M.M.F} = \text{Flux} \times \text{Reluctance} = \phi \times R$

5. **Reluctance:** Reluctance is the property of a magnetic material by virtue of which it opposes the creation of magnetic flux in it. Its unit is ampere turns per weber (AT/Wb).

It is directly proportional to the length of the magnetic material and inversely proportional to its area of cross section.

$$R = l / \mu a = l / \mu_0 \mu_r a$$

Where, l = length of the magnetic material

a = area of cross section

$\mu$  = a constant known as the absolute permeability of the magnetic material =  $\mu_0 \mu_r$

$\mu_0$  = permeability of the free space or air =  $4\pi \times 10^{-7}$  per metre ( H / m)

$\mu_r$  = relative permeability of the magnetic material.

6. **Permeability:** The ability of a material to conduct magnetic flux through it is called permeability of that material. Permeability of a material means its conductivity for magnetic flux. The greater the permeability of a material, the greater is its conductivity for magnetic flux and vice versa. It is represented by Greek letter  $\mu$ (mu).

7. **Absolute Permeability:** Absolute permeability of a magnetic material indicates the ability of that material to allow magnetic flux to be created in that material. Absolute permeability of air of vacuum is represented by  $\mu_0$  and its value is  $4\pi \times 10^{-7}$  H/m.

It can also be defined as the flux induced in the magnetic material per unit magnetizing force.

$$\mu = B/H, \text{ where, } H = \text{magnetizing force}$$

8. **Relative Permeability:** It is the ratio of the permeability of material ( $\mu$ ) to the permeability of air or vacuum ( $\mu_0$ ) is called Relative permeability of a that material .

$$\text{Relative permeability} = \text{permeability of material} / \text{permeability of air}$$

$$\mu_r = \mu / \mu_0$$

9. **Magnetic Field Strength Or Magnetic Field Intensity Of Magnetizing Force:** The Magnetic Field Intensity: at a point in a magnetic field in the force acting on a unit N- pole placed at that point. It is notated by the letter H. Its unit is Newton/ weber.

$$H = \text{Ampere turns/ Length} = NI/l \text{ AT/m}$$

10. **Magnetic Susceptibility:** The ratio between the intensity of magnetism produced in a substance to the magnetism force producers in it is called the magnetic susceptibility of the substance.

$$\text{Magnetic Susceptibility} = \text{Intensity of Magnetisation [I]} / \text{Magnetism Force [H]}$$

11. **Permeance:** It is the reciprocal of reluctance.

Permeance: It is also defined as the property of the magnetic circuit due to which it allows flow of the flux through it. Permeance = 1/Reluctance It is measured in weber per amperes (Wb/A).

### Analogy between electric and magnetic circuits

Electric Circuits	Magnetic Circuits
1. Path traced by the current is called as electric circuit	Path traced by the flux is called as magnetic circuit
2. E.M.F. drives current through an electric circuit .	M.M.F produces magnetic flux in a magnetic material.

E.M.F = current $\times$ resistance = $I \times R$	M.M.F = flux $\times$ reluctance = $\phi \times R$
3. Current density = $J = I/a$	Flux density = $B = \phi/a$
4. Resistance = $R = \rho l / a = l / \sigma a$	Reluctance = $R = l / \mu a$
5. Here KCL and KVL applicable to the electric circuit	Kirchoff's MMF, law and flux law is applicable to the magnetic circuit

**Magnetic field due to electric current**

When a current flows through a wire a magnetic field is produced. In figure 3(a) shows a straight conductor through which a steady current is flowing from left to right. The magnetic field lines will be in the form of concentric circles around the wire. The direction of this field is given by as we know from the Right hand thumb rule. “ Stretch the thumb of your right hand along the current, the curl(natural bend) of fingers gives the direction of the magnetic field”.

When the conductor is placed perpendicular to the paper. The conductor is represented by a small circle and the direction of current is then shown by putting a dot(.) or a cross (x) represents a current entering the paper (fig.1.2.3 c). In the fig1.2.3 b, the thumb is stretched upward and hence the magnetic field is anticlockwise. In fig.1.2.3 c, the thumb is stretched downward and the magnetic field is clockwise.

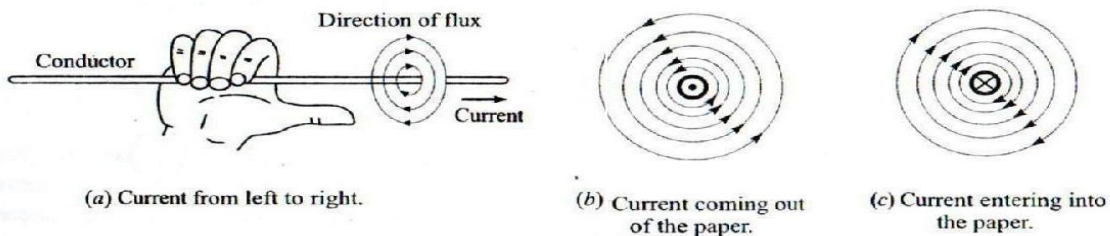

Fig:1.2.3. Magnetic field due to electric current in a conductor

### Magnetic field due to a Coil

The direction of magnetic field produced at the centre of a current carrying coil is also given by Right hand thumb rule. But here the role of current and magnetic field is exchanged: “ If you bend the fingers of the right hand pointing in the direction of current flow, the thumb points in the direction of magnetic field lines.”

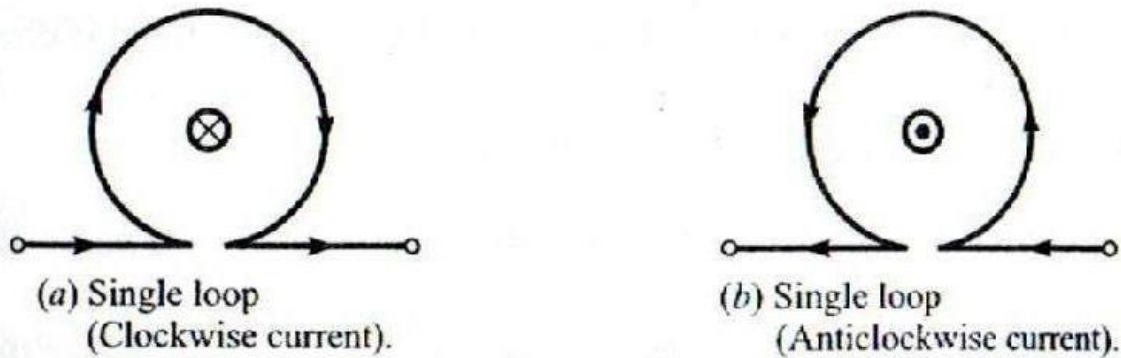

Fig:1.2.4. Direction of magnetic field due to current in a coil.

From the above fig.1.2.4(a) ,the current flow is clockwise, hence the magnetic field points downward. In even looking at fig.1.2.4 (b), the current flow in anticlockwise direction and the magnetic field points upwards. A coil thus acts like small flat magnet.

### Magnetic field due to a Solenoid

Solenoid is a wire which is wound closely in the form of a helix which is shown in fig.1.2.5. Here the wire is coated with an insulating material so that the adjacent turns are electrically insulated from each other. The length of the solenoid is large compared to its radius. The magnetic field flux produced by each turn tends to link up and the net field pattern is very similar to that of a bar magnet. By applying right hand thumb rule, we find that the left end of this solenoid is N-pole and right end is S-pole. The solenoids produce strong magnetic field for such applications as relays, transformers and circuit breakers.

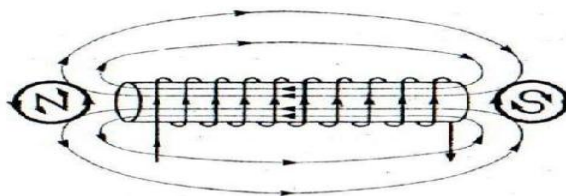

Fig:1.2.5. Magnetic field due to a coils of many turns.



**Force on a current carrying conductor placed in a magnetic field**

Consider a small conductor of length  $dl$  perpendicular to the magnetic field  $B$  which is shown in fig.1.2.6(a). If it carries a current  $I$ , it experiences a force given by

$$dF = I dl \times B \quad \dots\dots\dots 1$$

This is the magnetic analog of the electric force experienced by a charge  $q$  placed in an electric field  $E$ , given a  $F = q E$ . And hence we noticed that the force is proportional to  $I$ ,  $dl$  and  $B$  and is perpendicular to both  $dl$  and  $B$ .

From the fig.1.2.6(a) the angle between the length vector  $dl$  and the field  $B$  is 90 degree. Hence the expression of equation 1 reduces to  $dF = I dl B$ .

For a conductor of length  $l$ , carrying current  $I$  placed perpendicularly in the magnetic field of strength  $B$ , the force on the conductor is

$$F = I l B. \quad \dots\dots\dots 2$$

If the current carrying conductor placed at angle  $\theta$  to the magnetic field (fig1.2.6(c)), its effective length is

$l \sin\theta$ , and hence the force experienced by the conductor will be

$$F = I l B \sin\theta \quad \dots\dots\dots 3$$

and if the conductor is placed along the field  $B$ , the angle  $\theta = 0$ , and the force on the conductor reduces to zero.

And one of the best rule in finding the direction of force on a current carrying conductor placed in a magnetic field is Fleming's left hand rule. Statement of the rule is " Stretch the first finger and the thumb of your left hand in mutually perpendicular directions, the first finger points in the direction of magnetic field and the central finger to the direction of current, the thumb then points in the direction of force on the conductor.

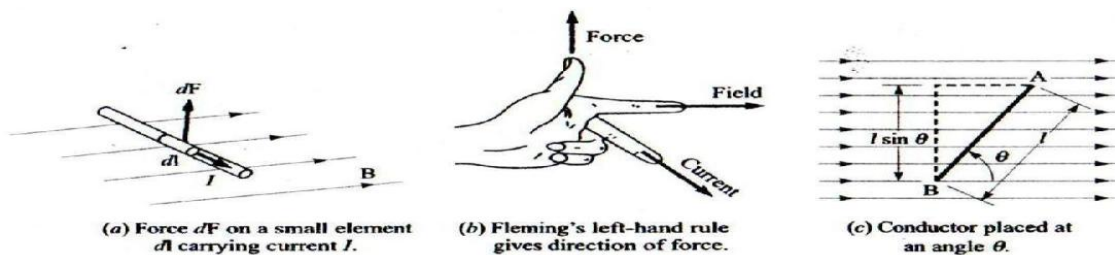

Fig:1.2.6. Force on a current carrying conductor

**Faraday’s Laws of Electromagnetic Induction:**

**Faraday’s First Law:**

Whenever the flux linking with a coil, a circuit changes an emf will be induced in the coil.

**Faraday’s Second Law:**

The magnitude of the induced emf in a coil is directly proportional to the rate of change of flux linking with the coil.

Consider a coil having  $N$  turns and the flux which is linking the coil changes from initial value i.e  $\phi_1$  Wb and changes to the final value to  $\phi_2$  Wb for the time  $t$  secs.

Therefore, E.M.F induced = Change in flux linkages/ Time Volts

$$e = N\phi_2 - N\phi_1 / t \text{ volts}$$

The above equation can be re-written as

$$e = N(\phi_2 - \phi_1) / t \text{ volts}$$

The equation or expression written in differential form ie

$$e = d(N\phi)/dt \text{ volts}$$

$$e = -N d\phi/dt \text{ volts}$$

and the notation for the above expression i.e.,  $e$  = emf induced in the circuit (volts)

$N$  = Number of turns of the coil

$d\phi$  = Change in flux

$dt$  = Change in time

and even in the above expression ‘-’ sign indicates that the induced emf sets current in such a direction that the magnetic effect produced by it opposes the very cause producing it.

**Lenz’s Law**

Statement: The direction of the induced emf is such that it opposes the very cause of it.

Mathematically it is expressed as  $e = -N d\phi/dt$ .

**Fleming’s Left Hand Rule:**

This rule is used to find out the direction of the force on the conductor. When the thumb, fore finger and the middle finger of the left hand are held perpendicular to each other in such a way that the fore finger is in the direction of the field, the middle finger in the direction of the current, then the thumb will point to the direction of motion (unknown). This rule is represented in fig:1.2.7 This rule is used in the D C Motors.

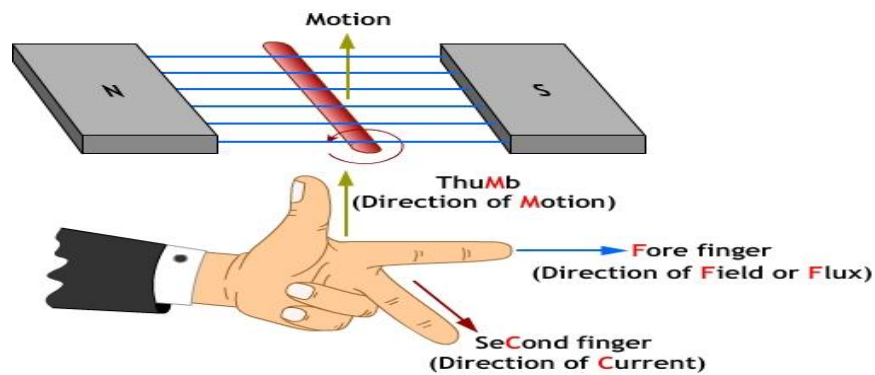
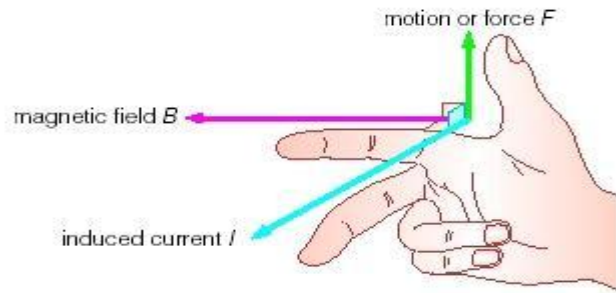

Fig:1.2.7(a). Fleming’s Left hand rule.[Ref: DSI ppt]

**Fleming’s Right Hand Rule:** When the thumb, forefinger and middle finger of the right hand are held mutually perpendicular to each other in such a way that, the thumb is in the direction of the motion of the conductor, the fore finger in the direction of magnetic field, then the middle finger shows the direction of the induced emf (unknown). This rule is represented in figure 7 b.

This rule is used in the D C Generators.



*Fig:1.2.7(b). Fleming' right rule. [Ref:DSI ppt]*

### Methods of producing induced emf:

There are two methods of producing induced emf

1. Dynamically induced emf
2. Statically induced emf

**Dynamically induced emf:** When a conductor is moved in a magnetic field or vice versa the flux linking the coil changes and an emf will be induced. This emf is called dynamically induced emf.

Consider the magnetic field with constant flux density  $B$  Tesla, represented by the magnetic lines of flux as shown in fig.1.2.8 (a) . Consider a conductor of length  $l$  and area of cross section  $a$  .

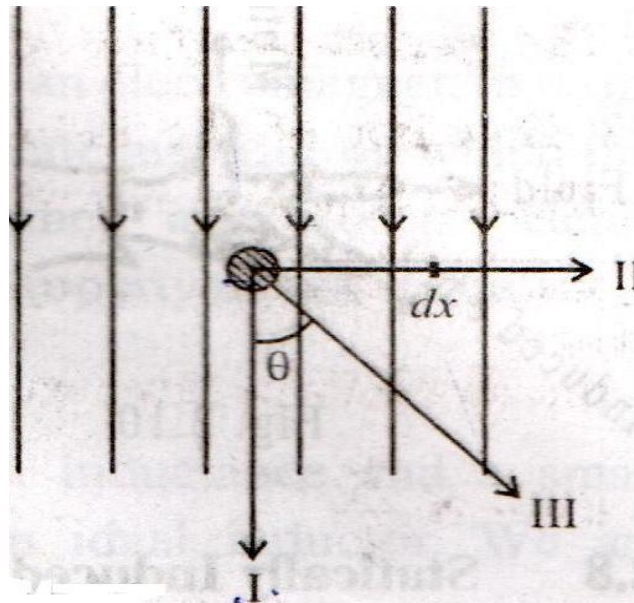

Fig:1.2.8(a) Dynamically induced emf.

The induced emf may be produced in the coil by the following three methods.

1. When the conductor is placed parallel to the direction of magnetic field
2. When the conductor is placed perpendicular to the direction of magnetic field
3. When the conductor moves in the direction of making an angle  $\theta$ , with the direction of magnetic lines of flux

1. When the conductor moves with the velocity  $v$  in the direction I, which is parallel to the lines of flux and hence it does not cut any flux. And hence no emf is induced.

2. When the conductor moves with the velocity  $v$  in the direction II, which is perpendicular to the lines of flux and hence it cuts the maximum flux. And hence emf is induced is also maximum. To find an expression for the maximum induced emf, let us consider the conductor moves through a small distance  $dx$  in  $dt$  seconds. Then the flux cut by the conductor is given by

$$d\phi = B \times l \, dx$$

The rate at which the flux is cut, is given by,

$$d\phi / dt = B \times l \, dx / dt = B l v$$

According to Faraday's laws of electromagnetic induction, the above equation is nothing but the emf induced in the conductor is maximum

$$\text{Therefore } e = B l v = E_m \text{ volts}$$

3. When the conductor moves in the direction III, of making an angle  $\theta$ , with the direction of magnetic lines of flux with the velocity  $v$ , the component of velocity perpendicular to the direction of flux is  $v \sin \theta$ , as shown in fig 1.2.8 (b). Hence, the emf induced in the conductor is  $B l v \sin \theta$

$$\text{Therefore } e = B l v \sin \theta = E_m \sin \theta \text{ volts}$$

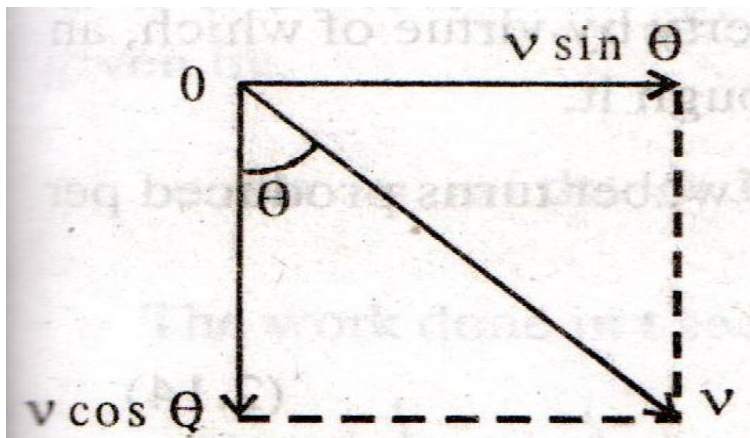

Fig:1.2.8(b) Changing angle  $\theta$

The component of velocity  $v \cos \theta$ , which is in the direction of the lines of flux, does not contribute anything for the emf induced. The direction of the dynamically induced emf is given by Fleming's Right Hand Rule.

**Statically induced emf:** When an ac voltage is applied to a coil, an alternating current flows through the coil, and the flux linking with the coil changes with respect to time. Hence an emf is induced in the coil. This emf is called statically induced emf.

Or

It can also be defined as when a conductor is stationary and the magnetic field is moving or changing, the emf induced is called statically induced emf.

Statically induced emf may be:

- a) Self-induced emf
- b) Mutually induced emf

**Self-induced emf:** When a current flowing through a coil changes, the flux linking with the coil also changes, which results in an emf and is called self-induced emf.

Mathematically,

$$e \propto di / dt \text{ or } e = L di / dt.$$

where L is called co-efficient of self-induction or self-inductance.

$$L = e / (di / dt).$$

**Co-efficient of Self Inductance(L) or Self Inductance:**

The self-inductance of a coil is its property by virtue of which, it always opposes any change in the value of the current flowing through it.

The self-inductance of a coil may also be defined as its property by virtue of which an emf is induced in it, whenever an alternating current flows through it.

The self-inductance of a coil may also be defined as the number of weber turns produced per ampere in the coil

$$L = N \phi / I = N N I / R = N^2 / l \mu_0 \mu_r a$$

$$L = \mu_0 \mu_r a N^2 / l \text{ Henry. } l \text{ is the length of the electromagnet.}$$

**Mutually Induced EMF:**

Consider two coils A and B placed close to each other and an alternating voltage is applied and the flux produced by one (A) coil is linked with the another (B) coil and due to change in this flux produced by first coil there is an induced emf in the second coil it is called mutually induced emf. and the emf induced in the first coil and the flux is produced is called self induced emf

Consider two coils of turns  $N_1$  and  $N_2$ , placed close to each other as shown in fig.1.2.9 (a)

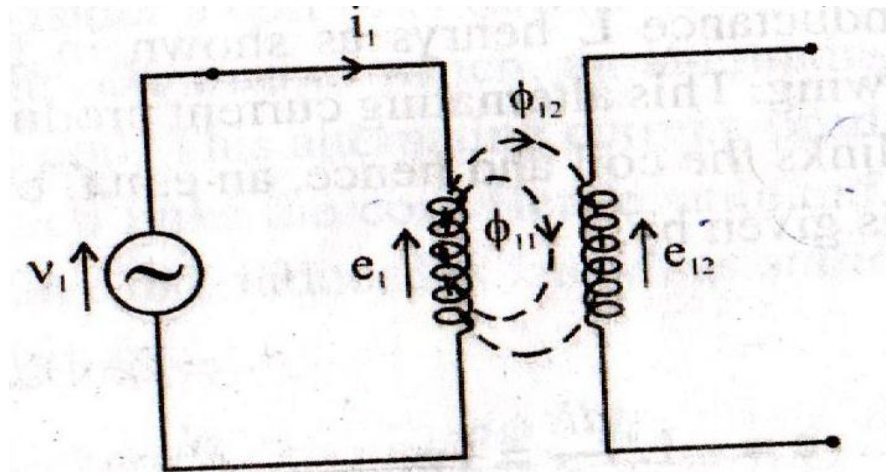

Fig:1.2.9( a) Mutually induced emf

$$e_1 = -N_1 \frac{d\phi_1}{dt} \text{ volts} \quad \dots\dots\dots 1$$

This is known as the self induced emf in the coil 1.

Due to flux of coil 1 also links the coil 2 . The flux  $\phi_{12}$  which links both the coil 1 and coil 2, which is called mutual flux between the two coils. The flux  $\phi_{11}$  links only coil1. Hence the flux  $\phi_1$  is the sum of the two fluxes

$$\phi_1 = \phi_{11} + \phi_{12} \quad \dots\dots\dots 2$$

The mutual flux  $\phi_{12}$  linking coil 2, induces an emf  $e_{12}$  in that coil. This emf is called as mutually induced emf and is given by

$$e_{12} = -N_2 \frac{d\phi_{12}}{dt} \quad \dots\dots\dots 3$$

The equation for  $e_{12}$  may also be written as

$$e_{12} = - M_{12} \frac{di_1}{dt} \quad \dots\dots\dots 4$$

= emf induced in coil 2, due to the current flowing in coil 1

$M_{12}$  is known as the mutual inductance between coil 1 and coil 2. The equation for the mutual inductance  $M_{12}$  may be written as

$$M_{12} = N_2 \frac{d\phi_{12}}{di_1} \quad \dots\dots\dots 5$$



Similarly, when coil 2 is supplied with alternating current  $i_2$ , producing a total flux  $\phi_2$  is shown in fig.1.2.9( b)

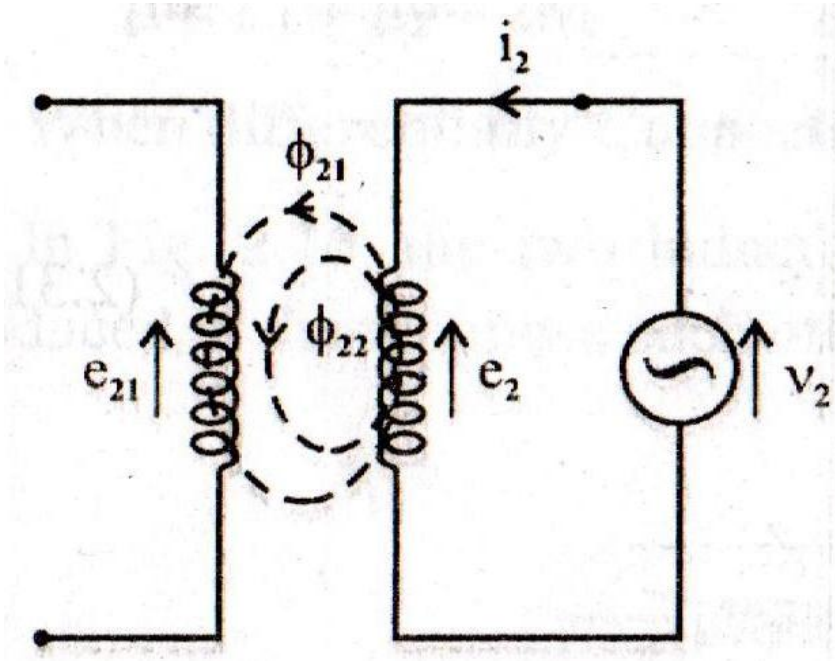

Fig:1.2.9( b) Mutually induced emf.

$$\phi_2 = \phi_{22} + \phi_{21} \dots\dots\dots 6$$

Where ,  $\phi_2$  = total flux produced in coil 2.

$\phi_{22}$  = flux that links only coil2

$\phi_{21}$  = flux that links both coil2 and coil1.

The self induced emf in coil 2 is given by

$$e_2 = -N_2 \frac{d\phi_2}{dt} \text{ volts} \dots\dots\dots 7$$

The mutually induced emf in coil1 is given by

$$e_{21} = -N_1 \frac{d\phi_{21}}{dt} = -M_{21} \frac{di_2}{dt} \dots\dots\dots 8$$

$$M_{21} = N_1 \frac{d\phi_{21}}{di_2}$$

$M_{21}$  is the mutual inductance between coil 2 and coil 1.

As the coupling between the two coils is bilateral, which means that, the coupled circuit has the same characteristics in both directions,

$$M_{12} = M_{21} = M \quad \dots\dots\dots 9$$

Hence, the mutual inductance between any two coils, placed close to each other, is defined as the ability of one coil to induce an emf in the other coil, when an alternating current flows through one of the coils.

$$M = N_2 d\phi_{12} / di_1 = N_1 d\phi_{21} / di_2 \quad \dots\dots\dots 10$$

**Co-Efficient of Coupling (K):**

The Co-Efficient of coupling is the ratio of the mutual flux to the total flux.

$$\therefore K_{12} = \phi_{12} / \phi_1 \quad \text{and} \quad K_{21} = \phi_{21} / \phi_2 \quad \dots\dots 11$$

As the coupling is bilateral  $K_{12} = K_{21} = K \quad \dots\dots 12$

$$\therefore \phi_{12} = K \phi_1 \quad \phi_{21} = K \phi_2 \quad \dots\dots\dots 13$$

From the equation 9 ie  $M_{12} = M_{21} = M$

$$M_2 = M_{12} \cdot M_{21} = N_2 d\phi_{12} / di_1 \times N_1 d\phi_{21} / di_2$$

$$\begin{aligned} N_1 N_2 d(K \phi_1) / di_1 \times d(K \phi_2) / di_2 &= K^2 N_1 d\phi_1 / di_1 \times N_2 d\phi_2 / di_2 \\ &= K^2 L_1 L_2 \end{aligned}$$

$$M = K \sqrt{L_1 L_2} \text{ or } K = M / \sqrt{L_1 L_2} \quad \dots\dots 14$$

**Energy Stored in a Magnetic Field**

Consider a pure inductive coil i.e an ideal inductor of having inductance L henry.

When the current flowing through a coil increases from zero to maximum value, the increase is opposed by the self-induced emf. and energy is needed to overcome this opposition is stored in the magnetic field of the coil.

Let i be the instantaneous value of the current

‘e’ be the induced emf due to current ‘i’ flowing in the coil

$$= L di/dt$$

Where  $L$  is the inductance of the coil in henry.

Work done in time  $dt$  to overcome this opposition is

$$\begin{aligned} dw &= ei \, dt \\ &= (Ldi/dt)idt \\ &= Lidi \end{aligned}$$

Total work done

$$\int dw = \int Li \, di$$

$$W = (1/2)LI^2 \text{ joules}$$

$$\text{Energy stored} = (1/2)LI^2 \text{ Joules}$$

And Inductance from Geometrical Viewpoint: Combining Faraday's law of electromagnetic induction equation

$$e = N \, d\phi/dt = L \, di/dt \text{ or } L = N \, d\phi/di \quad \dots\dots\dots 1$$

The rate of change of flux with current is constant and the above equation can be written as

$$L = N \, \phi/I \quad \dots\dots\dots 2$$

And also from the equation of flux and reluctance,

$$\Phi = NI/R \quad \dots\dots\dots \text{from definition of flux}$$

$$R = l/\mu A \quad \dots\dots\dots \text{from definition of reluctance}$$

And equation 2 becomes

$$L = N^2 \mu A/l \quad \dots\dots\dots 4$$

The above equation shows that the inductance depends on the physical dimensions of the coil and the magnetic properties of the core material.

**Problems:**

1. A wire of length 1m moves at right angles to its length at 60 meter per sec in a uniform magnetic field of density 1 Wb/m<sup>2</sup>. Calculate the emf induced in the conductor, when the

direction of motion is (a) Perpendicular to the field (b) Parallel to the field and (c) Inclined at 30 degree to the direction of the field.

Solution:

(a) When the conductor moves perpendicular to the direction of the field, emf induced is maximum.  $E = Blv$  volts =  $1 \times 1 \times 60 = 60$  volts

(b) When the conductor moves parallel to the lines of flux, emf induced is 0.

(c)  $e = Blv \sin \theta = 60 \times \sin 30 = 30$  volts

2. A coil consists of 600 turns and a current of 10A in the coil gives rise to a magnetic flux of 1 milliweber. Calculate i) Self inductance ii) The emf induced and iii) The energy stored when the current is reversed in 0.01 second.

Solution:

$$N = 600, I = 10A, \phi = 1 \text{ mWb}$$

I)  $L = N\phi/I = 600 \times 1 \times 10^{-3}/10 = 0.06$

II) Current is reversed in 0.01 sec i.e.  $I_2 = -10A, I_1 = 10A$

III)  $e = -LdI/dt = -L (I_2 - I_1)/\Delta t = -0.006[-10-10]/0.01 = 120\text{v}$

IV)  $E = \frac{1}{2} LI^2 = \frac{1}{2} \times 0.06 \times (10)^2 = 3\text{J}$

3. Two coils having 1,000 turns and 1,600 turns respectively are placed close to each other such that, 60% of the flux produced by one coil links the other. If a current of 10A, flowing in the first coil, produces a flux of 0.5 mWb, find the inductance of the second coil.

Solution:

$$L_1 = N_1 \phi_1 / I_1 = 1000 \times 0.5 \times 10^{-3} / 10 = 0.05\text{H}, k = 60\% = 0.6$$

$$M = N_2 \phi_{12} / I_1 = 1600 \times (0.5 \times 10^{-3} \times 0.6) / 10 = 0.048\text{H}$$

$$K = M / \sqrt{L_1 L_2} \text{ or } L_2 = M^2 / K^2 \times 1/L_1 = 0.048^2 / 0.6^2 \times 1/0.05 = 0.128$$

**MODULE-II(A)**

**SINGLE PHASE AC CIRCUITS.**

**Generation of Alternating Voltages and Currents:**

Alternating voltage may be generated:

1. By rotating coil in a magnetic field.
2. By rotating a magnetic field within a stationary coil.
3. In each case, the value of the alternating voltage generated depends upon the number of turns in the coil, the strength of the magnetic field and the speed at which the coil or magnetic field rotates.

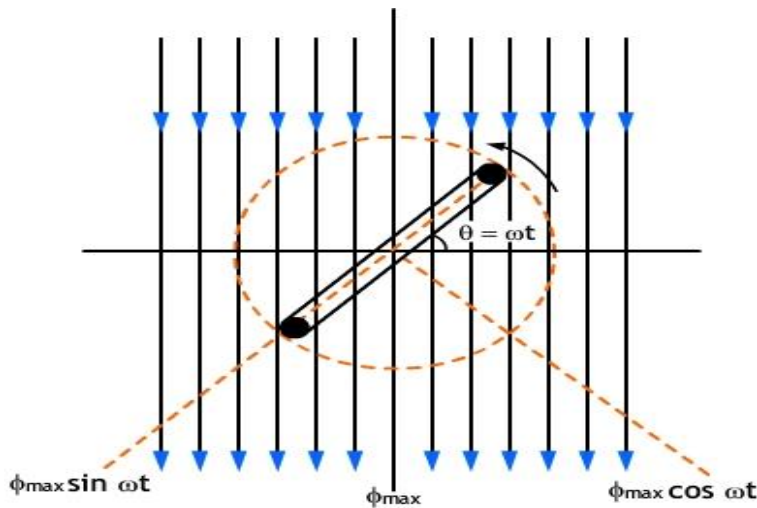

Fig:2.1.1. Generation of sinusoidal voltage.[Ref:DSI ppt]

Consider rectangular coil of  $N$  turns rotating in the anticlockwise direction, with an angular velocity of  $\omega$  radians per second in a uniform magnetic field as shown in figure. Time is measured from the instant of coincidence of the plane of the coil with the x-axis. At this instant maximum flux,  $\phi_{max}$ , links with the coil. As the coil rotates, the flux linking with it changes and hence e.m.f is induced in it. Let the coil turn through an angle  $\theta$  in time 't' seconds, and let it assume the position as shown in figure. Obviously  $\theta = \omega t$ .

When the coil is rotated, the maximum flux is acting vertically downwards. This flux can be resolved into two components, each perpendicular to the other, namely:

1. Component  $\phi_{\max} \sin\omega t$ , is parallel to the plane of the coil. This component does not induce e.m.f. as it is parallel to the plane of the coil.
2. Component  $\phi_{\max} \cos\omega t$ , is perpendicular to the plane of coil. This component induces e.m.f. in the coil.

$\therefore$  Flux linkages of coil at the instant (at  $\theta^0$ ) = No of turns \* flux =  $N\phi_{\max} \cos \omega t$

By Faraday's law of electromagnetic induction, instantaneous e.m.f. 'e' induced in a coil at the instant is given by

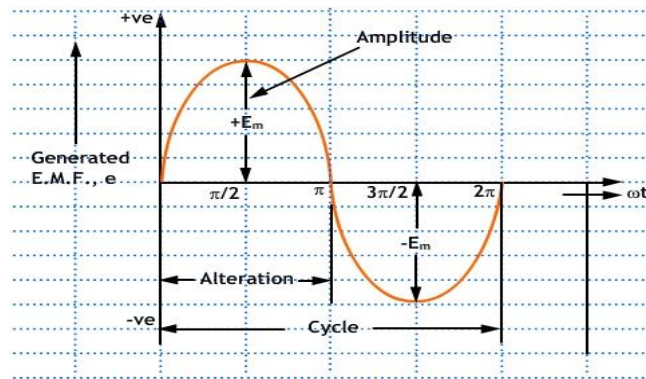

Fig:2.1.2. Generated sinusoidal waveform [Ref: DSI ppt]

$$= N \phi_{\max} \omega ( - \sin \omega t )$$

$$\therefore e = - N \omega \phi_{\max} \sin \omega t \text{ volts} \quad \text{----(i)}$$

From eqn. (i) e will be maximum ( $E_m$ ), when the coil has rotated through  $90^\circ$  (as  $\sin 90^\circ = 1$ ).

$$\text{Thus } E_m = N \omega \phi_{\max} \text{ volts} \quad \text{----(ii)}$$

Substituting the value of  $N\omega \phi_{\max}$  from equation (ii) in equation (i),

$$e = E_m \sin \omega t \quad \text{----(iii)}$$

We know that  $\theta = \omega t$

$$\therefore e = E_m \sin \theta$$

From the above expression the alternating e.m.f. induced in a coil is instantaneous and varies according to the sine of the angle ( $\theta$  or  $\omega t$ ).

As,  $\omega = 2\pi f$ , where 'f' is the frequency of rotation of the coil. Hence equation (iii) can be written as  $e = E_m \sin 2\pi ft$  -----(iv)

If T = time period of the alternating voltage =  $1/f$ , then eqn. (iv) becomes  $e = E_m \sin( (2\pi / T) t)$

The alternating quantity varies according to the sine function of the time angle  $\omega t$ , and if e.m.f. induced is plotted versus time, a curve is obtained which is called sinusoidal e.m.f.

### Important Definitions:

1. **Alternating quantity:** An alternating quantity is one which acts alternately in positive and negative directions, whose magnitude undergoes a definite series of changes in definite intervals of time and in which the sequence of changes while negative is identical with the sequence of changes while positive.
2. **Instantaneous value:** The value of an alternating quantity at any instant is called instantaneous value. 'e and i' represent the instantaneous values of alternating voltage and current respectively.
3. **Cycle:** A set of positive and negative half cycle (emf or current) is called one cycle.
4. **Time period and frequency:** The time taken in seconds by an alternating quantity to complete one cycle is known as time period and is denoted by T. The number of cycles completed per second by an alternating quantity is known as frequency and is denoted by 'f'. in hertz. The number of cycles per second = f.

$$\text{Time Period} = T = \text{Time taken for one cycle} = 1 / f \text{ or } f = 1 / T$$

In India, the standard frequency for power supply is 50 Hz and in USA it is 60Hz.

5. **Amplitude:** The maximum value of positive or negative alternating quantity during one complete cycle is called amplitude or peak value or maximum value.  $E_m$  and  $I_m$  represent the amplitude of alternating voltage and current respectively.
6. **Concept of leading and lagging:** If the two quantities (V and I) do not reach their peak at the same time then we can say that two quantities are having phase difference. The quantity which reaches its peak early is called leading. Quantity which reaches its peak later is called lagging. All the loads are either resistive or inductive in nature where current is in phase or lagging.

7. **Root-Mean-Square (R.M.S) Value:** The r.m.s. or effective value, of an alternating current is defined as that steady current which when flowing through a given resistance for a given time produces the same amount of heat as produced by the alternating current, when flowing through the same resistance for the same time.

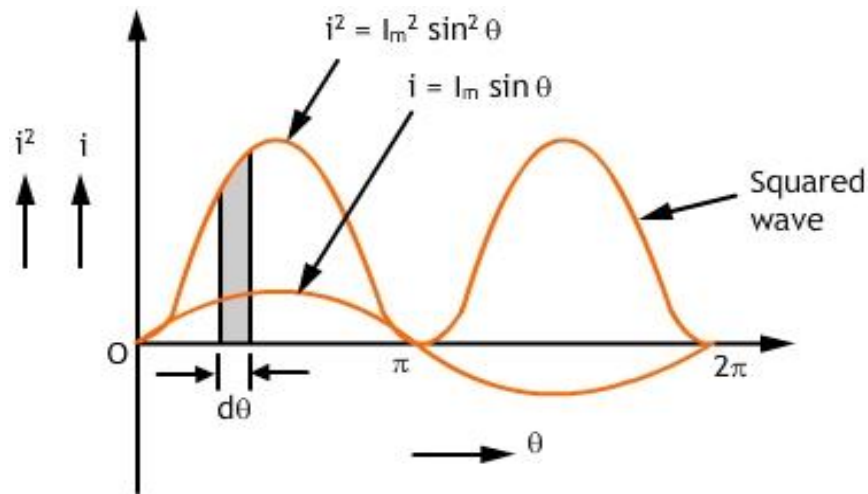

Fig:2.1.3. RMS value[Ref: DSI ppt]

This is an integral method and is very useful in finding the r.m.s. or effective value of sinusoidal waves. The equation of an alternating current varying sinusoidally is given by

$$i = I_m \sin \theta$$

Consider an elementary strip of thickness  $d\theta$  in the first half cycle of the squared wave, as shown in figure. Let  $i$  be the mid-ordinate of this strip.

$$\text{Area of the strip} = i d\theta$$

Area of first half-cycle of squared wave

$$\begin{aligned} &= \int_0^{\pi} i^2 d\theta \\ &= \int_0^{\pi} (I_m \sin \theta)^2 d\theta \quad (\because i = I_m \sin \theta) \\ &= \int_0^{\pi} I_m^2 \sin^2 \theta \cdot d\theta \\ &= I_m^2 \int_0^{\pi} \frac{1 - \cos 2\theta}{2} \cdot d\theta \quad (\because \sin^2 \theta = \frac{1 - \cos 2\theta}{2}) \end{aligned}$$



$$\begin{aligned}
 &= \frac{I_m^2}{2} \int_0^\pi (1 - \cos 2\theta) \cdot d\theta \\
 &= \frac{I_m^2}{2} \left[ \theta - \frac{\sin 2\theta}{2} \right]_0^\pi \\
 &= \frac{I_m^2}{2} [(\pi - 0) - (0 - 0)] \\
 &= \frac{\pi I_m^2}{2}
 \end{aligned}$$

$$\therefore I_{\text{rms}} = \sqrt{\frac{\text{Area of first half cycle of squared wave}}{\text{base}}}$$

$$I_{\text{rms}} = \sqrt{\frac{\pi I_m^2}{2} \times \frac{1}{\pi}}$$

$$I_{\text{rm}} = \sqrt{\frac{I_m^2}{2}}$$

$$I_{\text{rms}} = \frac{I_m}{\sqrt{2}} = 0.707 I_m$$

Hence, for a sinusoidal current,

R.M.S value of current,  $I = 0.707 \times$  maximum value of current.

Similarly,  $E = 0.707 E_m$

### Average Value:

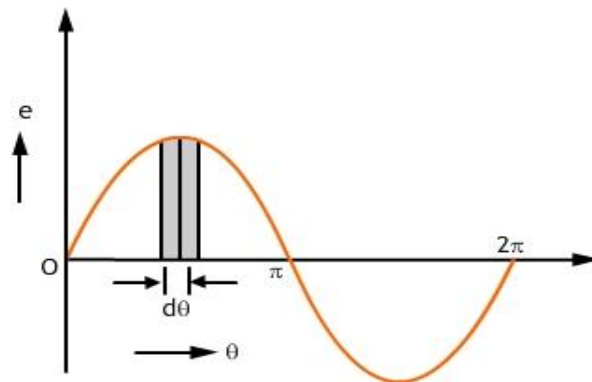

Fig:2.1.4. Average Value. [Ref:DSI ppt]

The equation of a sinusoidally varying alternating voltage is given by  $e = E_m \sin \theta$ .

Let us take an elementary strip of thickness  $d\theta$  in first half-cycle as shown in figure. Let the mid-ordinate of this strip be 'e'.

Area of the strip =  $e d\theta$

Area of first half- cycle =  $E_m \int \sin \theta d\theta = -E_m [-1 - 1] = 2E_m$

$\therefore$  Average value,  $E_{av} = \text{Area of half cycle} / \text{base} = 2E_m / \pi$

or  $E_{av} = 0.637 E_m$

Similarly, for alternating current varying sinusoidally,

$I_{av} = 0.637 I_m$

$\therefore$  **Average value of current = 0.637 \* maximum value.**

### Form Factor and Crest or Peak or Amplitude Factor ( $K_f$ ):

1. **Form factor:** The ratio of effective value (r.m.s value) to average value of an alternating quantity (voltage or current) is called form factor.

$$K_f = \text{RMS value} / \text{Average Value}$$

$$K_f = 0.707I_m / 0.637I_m$$

$$K_f = 1.11$$

2. **Crest or peak or amplitude factor ( $K_a$ ):** It is defined as the ratio of the maximum value to the r.m.s. value of an alternating quantity. **Crest factor** is important in the testing of dielectric strength of insulating materials, this is because the breakdown of insulating materials depends upon the maximum value of voltage.

$$K_p = I_m / 0.707I_m$$

$$K_p = 1.414$$

**(i)AC Circuit Containing Pure Resistance:** When an alternating voltage is applied to circuit containing pure resistance, alternating current will be flowing thro the circuit.

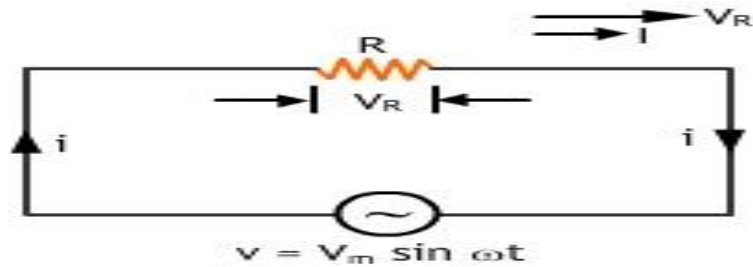

Fig:2.1.5. Pure Resistance circuit.[Ref: DSI ppt]

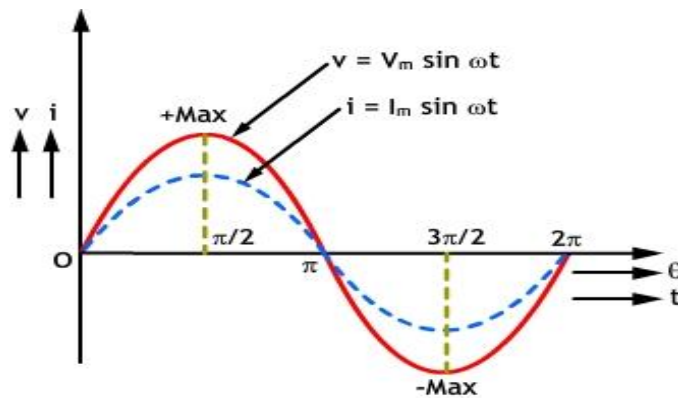

Fig:2.1.6. Current and voltage waveform[Ref: DSI ppt]

Consider an ac circuit with pure resistance ‘R’ as shown in figure.

Let the applied voltage  $v = V_m \sin \theta$  ----- (1)

Due to this applied voltage, current I will flow through the circuit. By ohm’s law  $V = IR$

Substituting the value of ‘v’ from equation (1) we get,

Current I is maximum when  $\sin\theta = 1$ , i.e.,

$\therefore i = I_m \sin \theta$  ----- (3)

**Power:**

Instantaneous power is given by  $P = V_m \sin \theta I_m \sin \theta$  i.e.,  $V_m I_m \sin^2 \theta$

Thus instantaneous power consists of a constant part and a fluctuating part of frequency double that of voltage.

The average value of over a complete cycle is zero.

or  $P = VI$  watts.

where,  $V$  = rms value of applied voltage and

$I$  = rms value of current.

**Power Curve:**

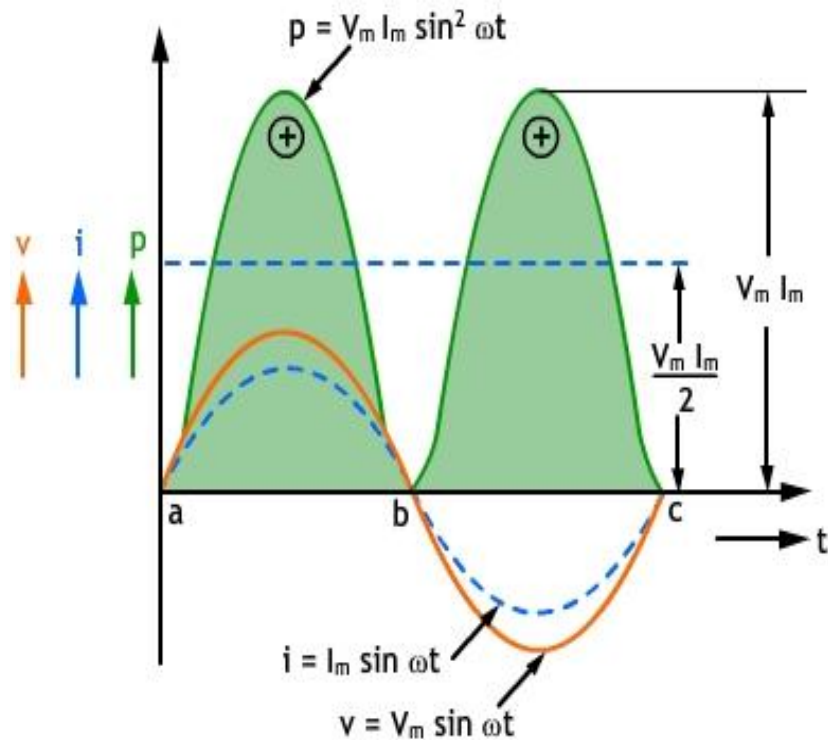

Fig:2.1.7. Power waveform of R circuit[Ref: DSI ppt]

ii) AC Circuit Containing Pure Inductance:

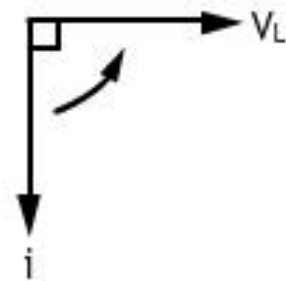
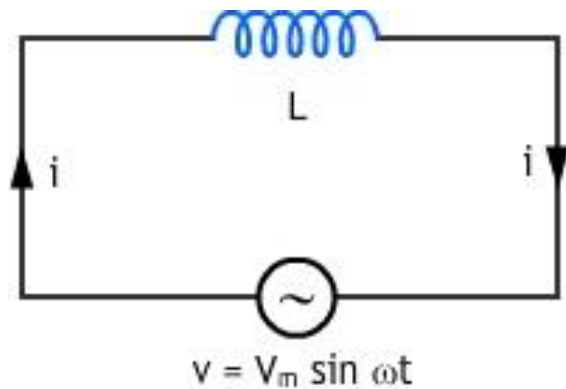

Fig:2.1.8(a) Pure inductance circuit

Fig:2.1.8(b) Phasor diagram

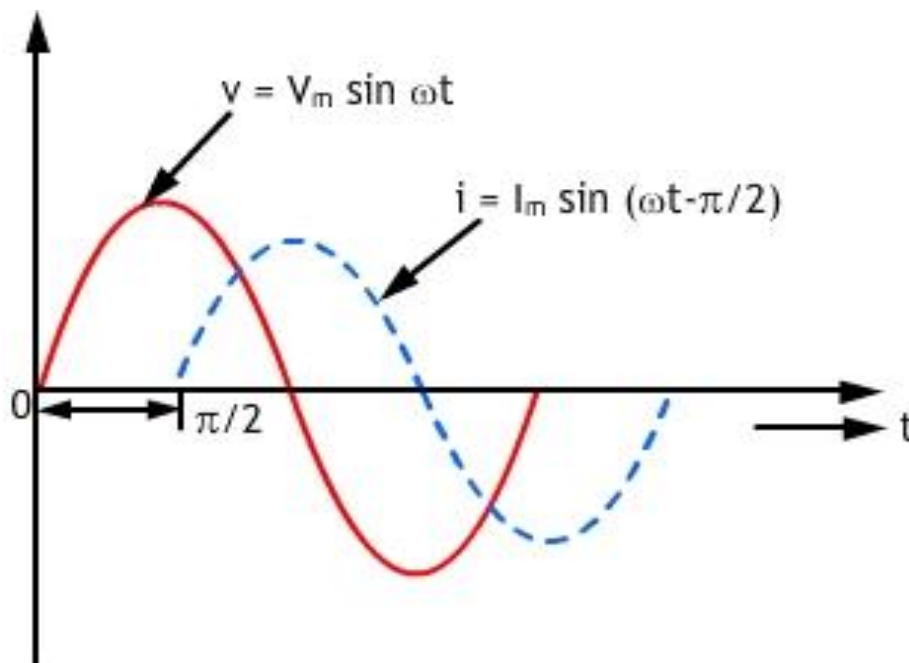

Fig:2.1.8(c) Current & voltage waveform [Ref:DSI ppt]

From the figure it is clear that current lags behind the applied voltage by  $\pi/2$

**Inductive Reactance:**  $\omega L = 2\pi fL$ , is known as inductive reactance in ohms and is denoted by  $X_L$  where  $L$  is in henry,  $f$  is in hertz.

Consider a purely inductive coil, back emf is produced due to the self-inductance of the coil. This back emf opposes the change in the current at every instant. Because of the absence of resistance, the applied voltage is equal to self-induced emf.

Let the applied voltage be  $v = V_m \sin \omega t$ , and the self-inductance of the coil =  $L$  Henry.

Self-induced e.m.f. in the coil,  $e_L = -L \frac{di}{dt}$

Since applied voltage at every instant is equal and opposite to the self-induced e.m.f., i.e.  $V = -e_L$

$$V_m \sin \omega t = - \left( -L \frac{di}{dt} \right)$$

$$\text{or } di = \frac{V_m}{L} \sin \omega t. dt$$

Integrating both sides, we get

$$i = \frac{V_m}{L} \int \sin \omega t. dt$$

or 
$$i = \frac{V_m}{\omega L} (-\cos \omega t) + A$$

Where  $A$  is a constant of integration which is found to be zero from initial conditions.

So, 
$$i = \frac{-V_m}{\omega L} \cos \omega t$$

Or 
$$i = \frac{V_m}{\omega L} \sin \left( \omega t - \frac{\pi}{2} \right)$$

Current ( $I$ ) will be maximum when  $\sin \left( \omega t - \frac{\pi}{2} \right) = 1$ , hence, the value of maximum current,  $I_m = \frac{V_m}{\omega L}$ , and instantaneous current may be expressed as  $i = I_m \sin \left( \omega t - \frac{\pi}{2} \right)$

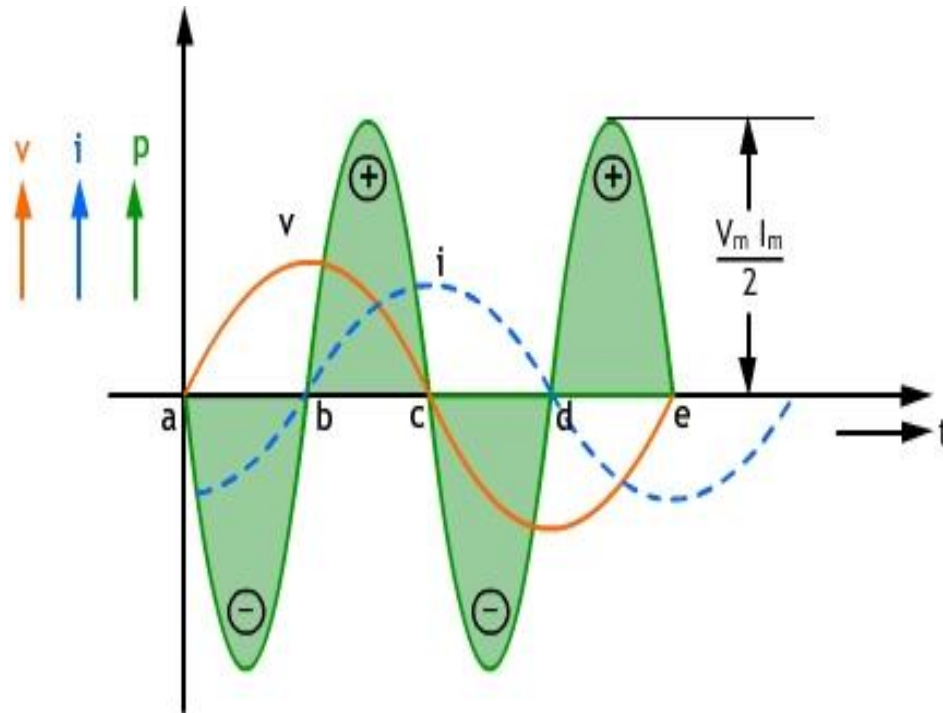

Fig:2.1.9 Power waveform[Ref:DSI ppt]

### Instantaneous power,

The average value of power for complete cycle is zero. Hence, power absorbed in a pure inductive circuit is zero.

**Power Curve:** The power curve for a pure inductive circuit is shown in figure. This indicates that power absorbed in the circuit is zero (positive power = negative power). Power is positive when both voltage and current are positive or negative if any one (v or i) is negative then power becomes negative.

**(iii) AC Circuit Containing Pure Capacitance:**

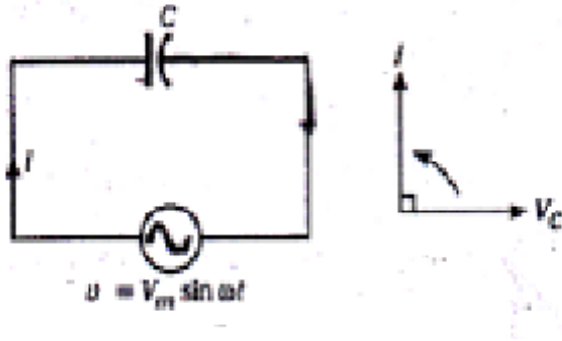

Fig:2.1.10 Pure capacitance circuit with phasor diagram [Ref: DSI ppt]

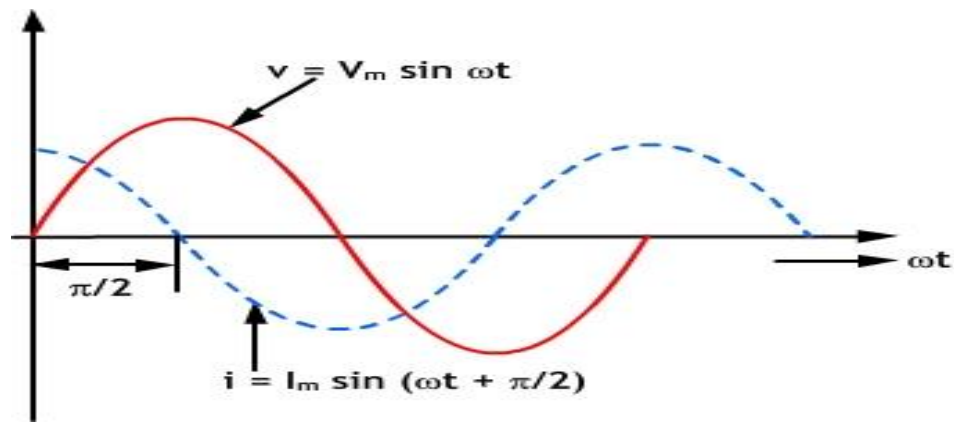

Fig:2.1.11. Pure capacitance circuit. [Ref:DSI ppt]

When an alternating voltage is applied across the plates of a capacitor, the capacitor is charged in one direction and then in the opposite direction as the voltage reverses.

Let alternating voltage represented by = 'V' volts be applied across a capacitor of capacitance C Farad.



Instantaneous charge,  $q = cv = CV_m \sin \omega t$

Capacitor current is equal to the rate of change of charge, or

$$i = \frac{dq}{dt} = \frac{d}{dt} (CV_m \sin \omega t) = \omega CV_m \cos \omega t$$

$$\text{or } i = \frac{V_m}{\frac{1}{\omega c}} \sin \left( \omega t + \frac{\pi}{2} \right)$$

The current is maximum when  $t = 0$ ,  $I_m = \frac{V_m}{\frac{1}{\omega c}}$

Substituting  $\frac{V_m}{\frac{1}{\omega c}} = I_m$  in the above expression for instantaneous current, we get

$$i = I_m \sin \left( \omega t + \frac{\pi}{2} \right)$$

**Capacitive Reactance:**  $\frac{1}{\omega c}$  in the expression  $I_m = \frac{V_m}{\frac{1}{\omega c}}$  is known as capacitive reactance and is denoted by  $X_c$ . i.e.,  $X_c = \frac{1}{\omega c}$

If  $C$  is farads and ' $\omega$ ' is in radians, then  $X_c$  will be in ohms.

If the applied voltage is given by  $v = V_m \sin \omega t$ , then the

current is given by  $i = I_m \sin \left( \omega t + \frac{\pi}{2} \right)$

This shows that the current in a pure capacitor leads its voltage by a quarter cycle as shown or phase difference between its voltage and current is  $\frac{\pi}{2}$  with the current leading

$1/\omega c$  is known as capacitive reactance and is denoted by  $X_c$

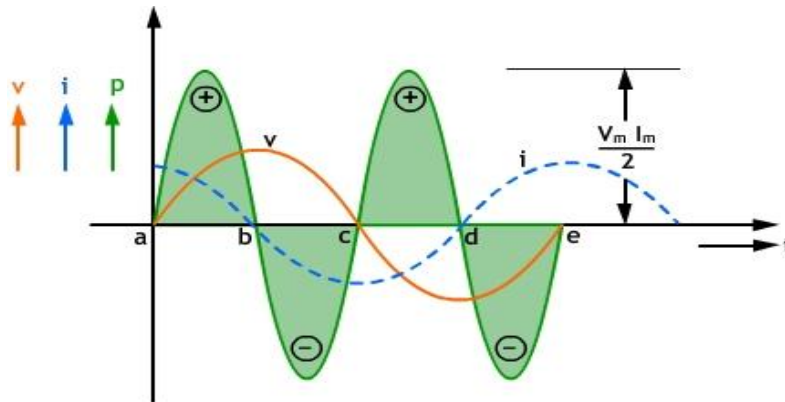

Fig:2.1.12. Power waveform[Ref: DSI ppt]

**Power Curve:** The power curve for a pure capacitive circuit is shown in figure. This indicates that power absorbed in the circuit is zero (positive power = negative power). Power is positive when both voltage and current are positive or negative. If any one ( $v$  or  $i$ ) is negative then power becomes negative.

**R-L Series Circuit:**

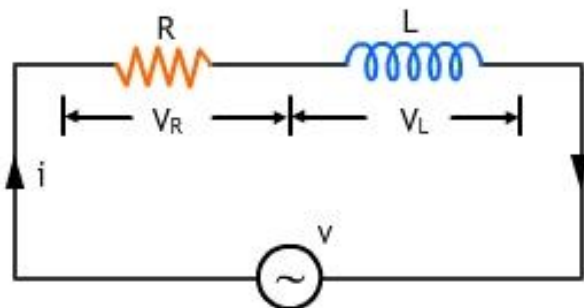

Fig:2.1.13(a). R-L series circuit

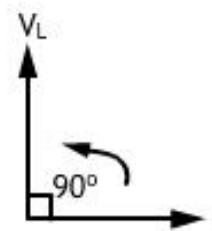

Fig:2.1.13(b) Phasor Diagram of 'L'

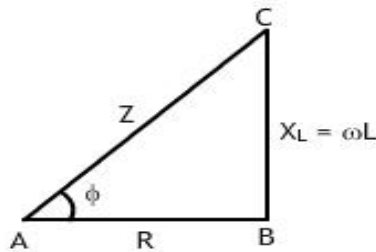

Fig:2.1.13(c) Impedance triangle [Ref:DSI ppt]

Let  $V$  = r.m.s. value of the applied voltage

$I$  = r.m.s. value of the current

Voltage drop across  $R$ ,  $V_R = IR$  (in phase with  $I$ )

Voltage drop across  $L$ ,  $V_L = IX_L$  (leading  $I$  by  $90^\circ$ )

The voltage drops across these two circuit components are shown, where vector  $AB$  indicates  $V_R$  and  $BC$  indicates  $V_L$ . The applied voltage  $V$  is the vector sum of the two  $AC$  ( $Z$ .)

$$V = \sqrt{V_R^2 + V_L^2} = \sqrt{(IR)^2 + (IX_L)^2}$$

$$= I \sqrt{R^2 + X_L^2}$$

$$\therefore I = \frac{V}{\sqrt{R^2 + X_L^2}}$$

The term  $\sqrt{R^2 + X_L^2}$  offers opposition to current flow and is called the impedance ( $Z$ ) of the circuit. It is measured in ohms.

$$I = \frac{V}{Z}$$

$$Z^2 = R^2 + X_L^2$$

$$\tan \phi = \frac{V_L}{V_R} = \frac{IX_L}{IR} = \frac{X_L}{R} = \frac{\omega L}{R} = \frac{\text{reactance}}{\text{resistance}}$$

$$\therefore \phi = \tan^{-1} \frac{X_L}{R}$$

The circuit current lags behind applied voltage by an angle  $\phi$ . So, if applied voltage is expressed as  $v = V_m \sin \omega t$ , the current is given by  $i = I_m (\sin \omega t - \phi)$ , where  $I_m = V_m / Z$

**Power:**

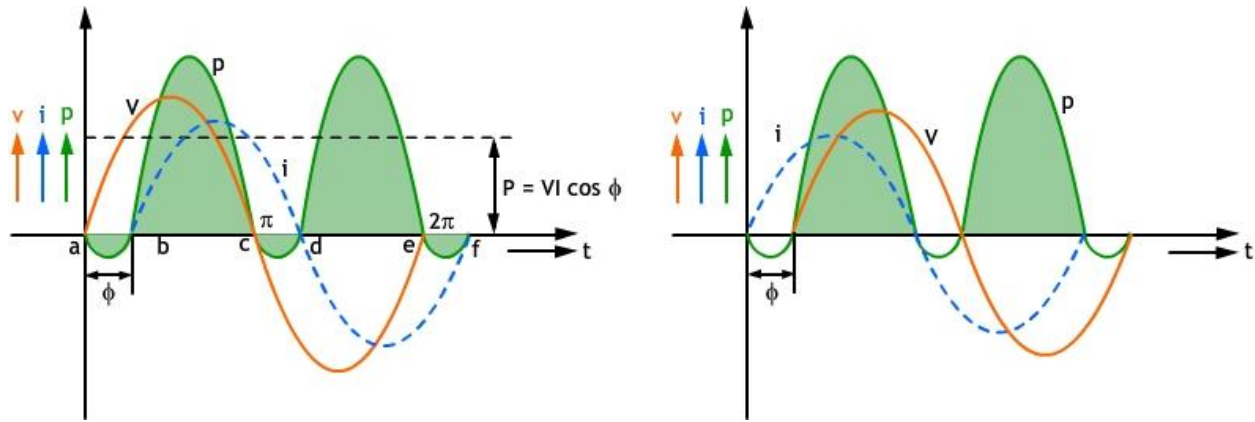

Fig:2.1.14(a) Power waveform[R-L series]

Fig:2.1.14(b) Power waveform[R-C series]

Ref:DSI ppt.

Instantaneous power,  $P = vi = V_m \sin \omega t \times I_m \sin(\omega t - \phi)$

$$= V_m I_m \sin \omega t \cdot \sin(\omega t - \phi)$$

$$= \frac{1}{2} V_m I_m [\cos \phi - \cos(2\omega t - \phi)]$$

Average power consumed,  $P = \frac{1}{2} V_m I_m \cos \phi$

$$P = \frac{V_m}{\sqrt{2}} \cdot \frac{I_m}{\sqrt{2}} \cos \phi$$

$$P = V I \cos \phi$$

Where V and I are r.m.s. values of voltage and current

**Apparent Power:** The product of rms. values of current and voltage, VI, is called the apparent power and is measured in volt-amperes (VA) or in kilo-volt amperes (KVA).

$$S=VI$$

**Real Power:** The product of the applied voltage and the active component of the current is known as real power. It is expressed in watts or kilo-watts (kW).

$$P= VI \cos\Phi$$

**Reactive Power:** It is defined as product of the applied voltage and the reactive component of the current. It is expressed in volt-ampere reactive (VAR) or kilo volt ampere (kVAR)

$$Q = VI \sin \Phi$$

**R-C Series Circuit:**

Consider an ac circuit containing resistance R ohms and capacitance C farads, as shown in the figure

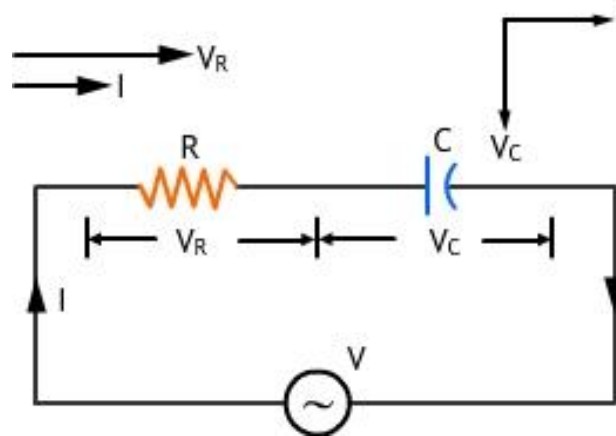
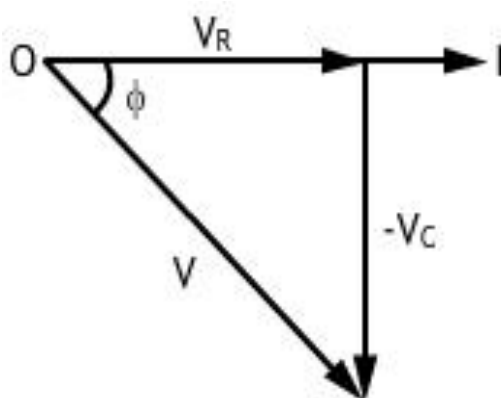

Fig:2.1.15. R-C series circuit[Ref:DSI ppt]



Z is impedance of the circuit

Fig:2.1.16(a) Voltage triangle

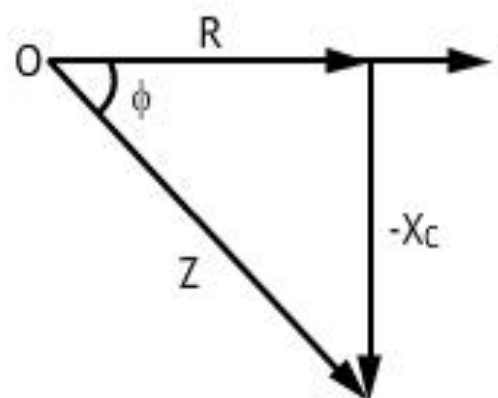

Fig:2.1.16(b) Impedance triangle.

Let  $V$  = r.m.s. value of voltage,  $I$  = r.m.s. value of current

Voltage drop across  $R$ ,  $V_R = IR$

Voltage drop across  $C$ ,  $V_C = IX_C$

The capacitive resistance is negative, so  $V_C$  is in the negative direction of  $Y$  axis, as shown

$$V = \sqrt{V_R^2 + (-V_C)^2} = \sqrt{(IR)^2 + (-IX_C)^2}$$

$$V = \sqrt{R^2 + X_C^2} I$$

Or 
$$I = \frac{V}{\sqrt{R^2 + X_C^2}} = \frac{V}{Z}$$

Power factor,  $\cos \phi = \frac{R}{Z}$ ,  $I$  leads  $V$  by an angle,  $\tan \phi = \frac{-X_C}{R}$

**Power:** Average power,  $P = v \times i = VI \cos \phi$

**Series R-L-C circuit:**

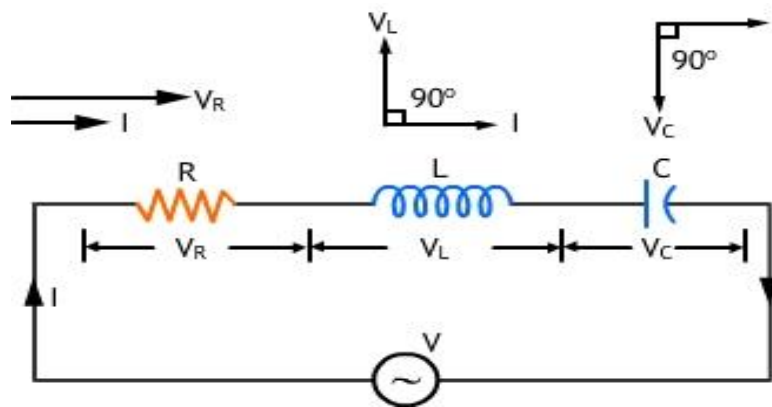

Fig:2.1.17. Series R-L-C circuit. [Ref:DSI ppt]

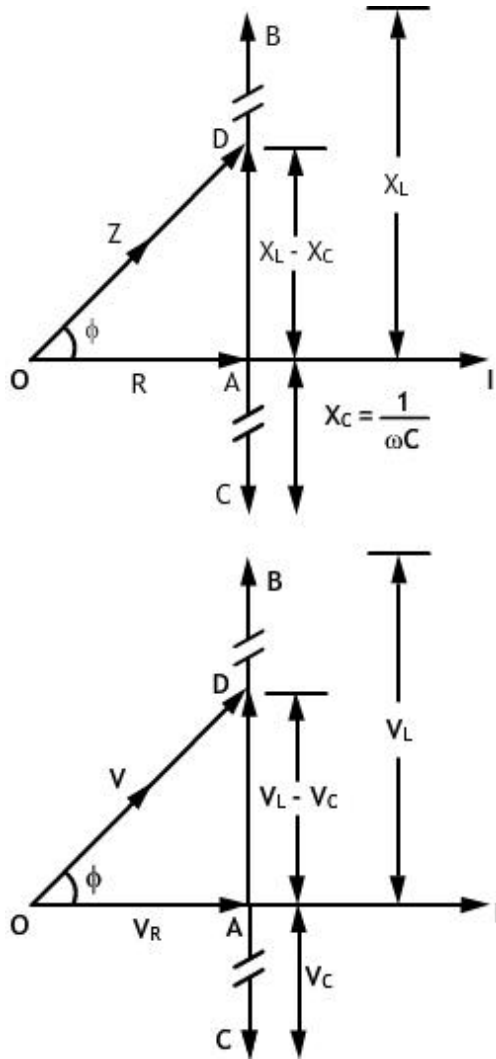

Fig:2..1.18 Phasor diagram of R-L-C series circuit

Consider an a.c. series circuit containing resistance 'R' ohms, Inductance 'L' henries and capacitance 'C' farads, as shown above.

Let  $V$  = r.m.s. value of applied voltage . $I$  = r.m.s. value of current

Voltage drop across R,  $V_R = IR$

Voltage drop across L,  $V_L = IX_L$

Voltage drop across C,  $V_C = IX_C$

$$AD = AB - AC$$

$$= AB - BD \quad (\text{because } BD = AC)$$

$$= V_L - V_C$$

$$= I(X_L - X_C)$$

OD, which represents the applied voltage V, is the vector sum of OA and AD.

$$\therefore OD = \sqrt{OA^2 + AD^2} \text{ or } V = \sqrt{(IR)^2 + (IX_L - IX_C)^2}$$

$$= I\sqrt{R^2 + (X_L - X_C)^2}$$

$$I = V/\sqrt{R^2 + (X_L - X_C)^2} = V/Z.$$

The denominator  $\sqrt{R^2 + (X_L - X_C)^2}$  is the impedance of the circuit.

$$Z^2 = R^2 + (X_L - X_C)^2 = R^2 + X^2$$

Phase angle  $\phi$  is given by

$$\tan \phi = \frac{(X_L - X_C)}{R} = \frac{X}{R}$$

Power factor,

$$\cos \phi = \frac{R}{Z} = \frac{R}{\sqrt{R^2 + (X_L - X_C)^2}} = \frac{R}{\sqrt{R^2 + X^2}}$$

$$\text{Power} = VI \cos \phi$$

If  $X_C > X_L$ , then the current leads and the +ve sign is used

If  $X_L > X_C$ , then the current lags and the -ve sign is used

$$Z = R + j(X_L - X_C)$$

The value of the impedance is

$$Z = \sqrt{R^2 + (X_L - X_C)^2}$$

$$\text{The phase angle } \phi = \tan^{-1} \frac{(X_L - X_C)}{R}$$

$$Z \angle \phi = Z \angle \tan^{-1} \left[ \frac{X_L - X_C}{R} \right]$$

$$Z \angle \phi = Z \angle \tan^{-1} \left[ \frac{X}{R} \right]$$



**Parallel Circuit:**

In a parallel ac. circuit, the voltage across each branch of the circuit is the same whereas current in each branch depends upon the branch impedance. Since alternating currents are vector quantities, total line current is the vector sum of branch currents. Three methods of solving parallel ac. circuits:

- Vector method.
- Admittance method.
- Symbolic or j- method.

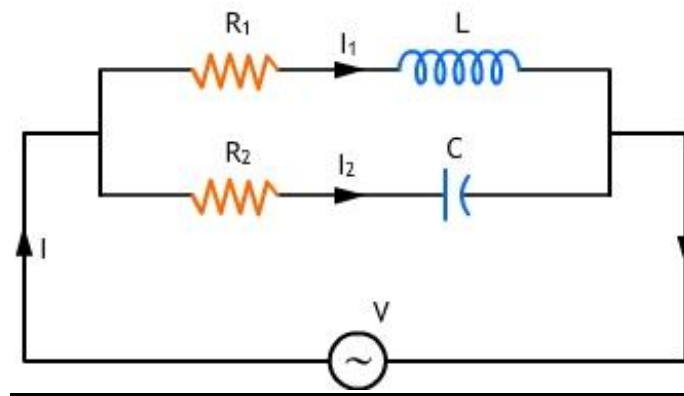

Fig: 2.1.19 Parallel circuit[Ref: DSI ppt]

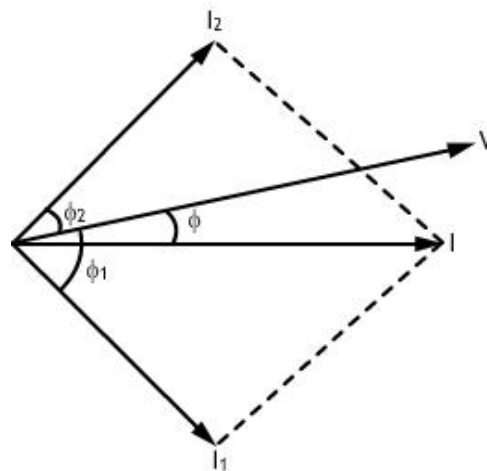

Fig: 2.1.20 Phasor diagram[Ref DSI ppt]

**Branch 1**

Current  $I_1$  lags behind the applied voltage by  $\phi_1$ .

**Branch 2**

Current  $I_2$  leads V by  $\phi_2$ .

**Resultant Current:**

$$I = \sqrt{(I \cos \phi)^2 + (I \sin \phi)^2}$$

$$\text{or } I \cos \phi = I_1 \cos \phi_1 + I_2 \cos \phi_2$$

$$\text{or } I \sin \phi = I_1 \sin \phi_1 - I_2 \sin \phi_2$$

$$I = \sqrt{(I_1 \cos \phi_1 + I_2 \cos \phi_2)^2 + (I_1 \sin \phi_1 - I_2 \sin \phi_2)^2}$$

If  $\tan \phi$  is positive, current leads and if  $\tan \phi$  is negative, then the current lags behind applied voltage V.

**Problems:**

1. A series R-L circuit takes 384 W at a power factor of 0.8 from a 120 V, 60 Hz supply. What are the values of R and L?

**Solution:**

Given:  $V = 120 \text{ V}$ ,  $f = 60 \text{ Hz}$ ,  $P = 384 \text{ W}$  and  $\cos \phi = 0.8$

$$P = VI \cos \phi = 384$$

$$120 I \times 0.8 = 384$$

$$I = 4 \text{ A}$$

$$\text{Impedance, } Z = V/I = 120/4 = 30 \Omega$$

$$\text{Resistance, } R = Z \cos \phi = 30 \times 0.6 = 18 \Omega$$

$$\text{Now, } X_L = 2\pi fL = 18 \Omega$$

$$\therefore L = 18 / 2\pi \times 60 = \mathbf{0.047 \text{ H}}$$

2. A voltage of 200 V is applied to a series circuit consisting of a resistor, an inductor and a capacitor. The respective voltages across these components are 170, 150 and 100 V and the current is 4 A. Find the power factor of the circuit.

**Solution:**

$$\text{Current} = 4\text{A}, \quad V_R = IR = 170, \quad 4R = 170$$

$$\therefore R = 42.5 \Omega$$

$$V_L = I X_L = 150$$

$$\therefore X_L = 150 / 4 = 37.5 \Omega$$

$$V_C = I X_C = 100$$

$$\therefore X_C = 25 \Omega$$

Impedance,

$$Z = \sqrt{R^2 + (X_L - X_C)^2}$$

$$= \sqrt{42.5^2 + 12.5^2} = 44.3 \Omega$$

Power Factor,

$$\cos \phi = R / Z$$

$$= 42.5 / 44.3 = \mathbf{0.96(\text{lagging})}$$

3. Find the reading of the ammeter when the voltmeter across the 3-ohm resistor in the circuit shown in figure below reads 45 V.

**Solution:**

$I_1 = 45 / 3 = 15 \text{ A.}$ ,  $I_1 = 15 \angle 0^\circ \text{ A}$  The applied voltage  $V = 15 \angle 0^\circ \times (3 - j3)$

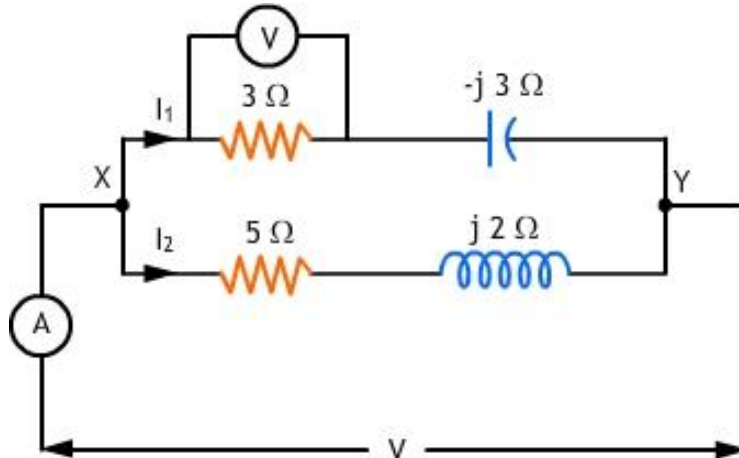

$$= 15 \angle 0^\circ \times 4.24 \angle -45^\circ$$

$$= 63.6 \angle -45^\circ \text{ V}$$

$$I_2 = V / Z_2 = 63.6 \angle -45^\circ / (5 + j2)$$

$$= 63.6 \angle -45^\circ / 5.4 \angle 21.8^\circ$$

$$= \mathbf{11.77 \angle -66.8^\circ \text{ A}}$$

$$I_2 = 11.77(\cos 66.80 - j \sin 66.80)$$

$$= 11.77(0.3939 - j0.9191)$$

$$= 4.64 - j10.8$$

$$I = I_1 + I_2 = (15 + j0) + (4.64 - j10.8)$$

$$I = 19.64 - j10.8$$

$$= \sqrt{(19.64)^2 + (-10.8)^2} \angle -\tan^{-1} 0.55$$

$$= \sqrt{385.7} + 116.6 \angle -28.8^\circ$$

$$= 22.4 \angle -28.8^\circ \text{ A}$$

Hence, ammeter reads **22.4A**

**MODULE-II(B)**

**THREE PHASE ALTERNATING CURRENT CIRCUITS**

There are two types of system available in electric AC circuit, single phase and three phase system. In single phase circuit, there will be only one phase, i.e the current will flow through only one wire and there will be one return path called neutral line to complete the circuit.

A poly phase system is a combination of several single-phase voltages having the same magnitude and frequency but displaced from one another by equal angle (electrical), which depends on the number of phases and determined from the following relation:

Electrical displacement =  $360^0$  electrical degree/ number of phases

There fore for three phase system =  $360/3 = 120^0$

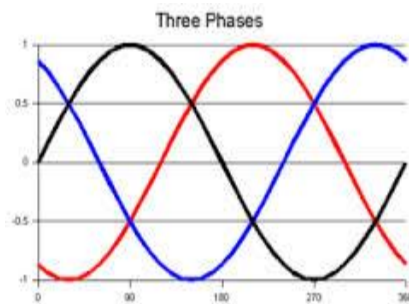

**Three phase circuit** is the polyphase system where three phases are send together from the generator to the load. Each phase are having a phase difference of  $120^{\circ}$ , i.e  $120^{\circ}$  angle electrically. So from the total of  $360^{\circ}$ , three phases are equally divided into  $120^{\circ}$  each. The power in **three phase system** is continuous as all the three phases are involved in generating

the total power. The sinusoidal waves for 3 phase system is shown below fig 1

*Fig :2.2.1. Wave forms of 3 phase voltages [Ref : Wikipedia.]*

The three phases can be used as single phase each. So if the load is single phase, then one phase can be taken from the three phase circuit and the neutral can be used as ground to complete the circuit.

**Advantages of Three-Phase Systems:**

- The output of a three-phase machine is always greater than that of a single-phase machine of the same size and less cost.

- For transmission and distribution of a power over a given distance, a three-phase transmission line requires less copper than a single-phase line.
- Three phase motors have uniform torque compared to 1-phase motors.
- Single-phase motors are not self-starting. Three phase motors are self-starting.
- Three phase generators work in parallel without difficulty.
- In the case of three-phase star system, two different voltages can be obtained whereas in the case of a single-phase system only one voltage can be obtained.
- Overall performance of 3- phase motors is better compared to 1-phase motor.

**Generation of three phase voltage:**

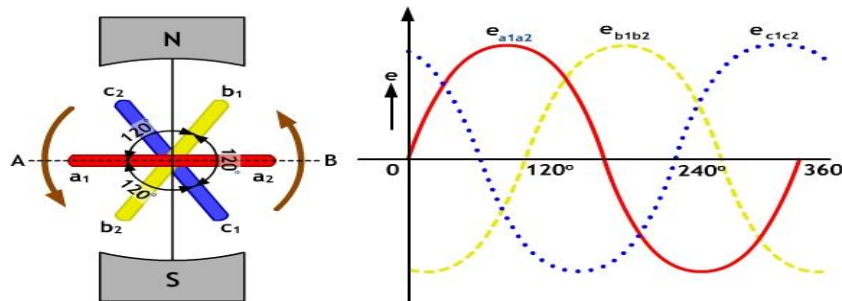

Fig: 2.2.2 Generation of 3 phase voltage [Ref : threephasepower.org]

Consider three electrical coils  $a_1 a_2$ ,  $b_1 b_2$  and  $c_1 c_2$  as shown in the fig 2 mounted on the same axis but displaced from each other by  $120^\circ$  electrical. Let the three coils be rotated in anticlockwise direction in a magnetic field with an angular velocity of  $\omega$  radians/sec, as shown.

When the coil  $a_1 a_2$  is moved with the position AB shown in figure, the magnitude and direction of the emf's induced in the various coils is as under;

- a) E.M.F induced in coil  $a_1 a_2$  is zero and is increasing in the positive direction. This is indicated by  $e_{a_1 a_2}$  wave in figure

$$\Rightarrow e_{a_1 a_2} = E_m \cdot \sin \omega t = e_r$$

- b) The coil  $b_1 b_2$  is  $120^\circ$  electrically behind coil  $a_1 a_2$ . The emf induced in this coil is negative and is approaching maximum negative value. This is shown by the  $e_{b_1 b_2}$  wave

$$\Rightarrow e_{b_1 b_2} = E_m \cdot \sin [\omega t - 2\pi / 3] = e_y$$

- c) The coil  $c_1 c_2$  is  $240^\circ$  electrically behind  $a_1 a_2$  or  $120^\circ$  electrically behind coil  $b_1 b_2$ . The emf induced in this coil is positive and is decreasing. This is indicated by  $e_{c_1 c_2}$  wave

$$\Rightarrow e_{c_1 c_2} = E_m \sin [\omega t - 4\pi / 3] = e_b$$

If the three voltages are added vectorially, it can be observed that the sum of the three voltages at any instant is zero.

$$\text{That is } e_r + e_y + e_b = 0.$$

### Important definitions related to three phase system.

- **Symmetrical system** : a three phase system in which the three voltages are of same magnitude and frequency and displaced from each other by 120 degree phase angle is called as symmetrical system.
- **Phase sequence** : The order in which the voltages in the phases reach their maximum positive values is called the phase sequence. Three phases are usually represented by R-Y-B and should be connected in this order called phase sequence. (Red, Yellow, Blue).

### Three phase supply connections:

- In single phase system, two wires are sufficient for transmitting voltage to the load that is phase and neutral. But in case of three phase, two ends of each phase are available to supply voltage to the load.
- Using these connections two different three phase connections can be obtained which are called as Star connection and Delta connection.

### Star connection:

- The star connection is formed by connecting starting ends of all the three windings together. The common point is known as Neutral point. The remaining three ends are brought out for connection to load. Star connected circuit is illustrated in the fig

### Delta connection:

- The delta is formed by connecting one end of winding to starting end of other which forms a closed loop.
- The supply terminals are taken out from three junction points.
- Delta connection always forms a closed loop. Delta connected circuit is illustrated in fig

### Concept of Line and Phase values of Voltages and Currents.

- The potential different between any two lines of supply is called line voltage and current passing through any line is called line current. Line voltages are denoted as  $E_L$
- Line current are denoted by  $I_L$  .
- The voltage across any branch of the three phase load is called phase voltage and the current passing through any branch of the three phase load is called phase current.

### Balanced Supply

A supply is said to be balanced if all three voltages are equal in magnitude and displaced by 120 degree. A three phase supply can be connected in two ways - Either in Delta connection or in Star connection as shown in the figure 3.

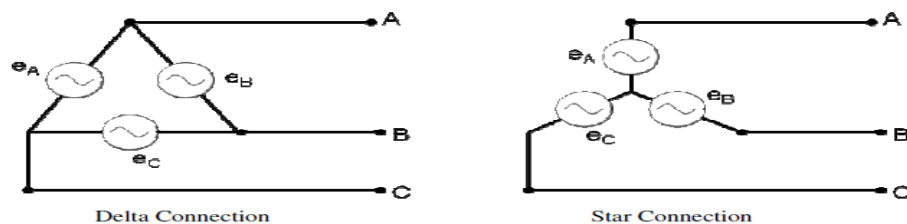

Fig:2.2.3 Balanced supply [Ref : Wikipedia.]

### Balanced Load

A load is said to be balanced if the impedances in all three phases are equal in magnitude and phase. A three phase load can be connected in two ways – Either in Delta connection or in Star connection as shown in the fig



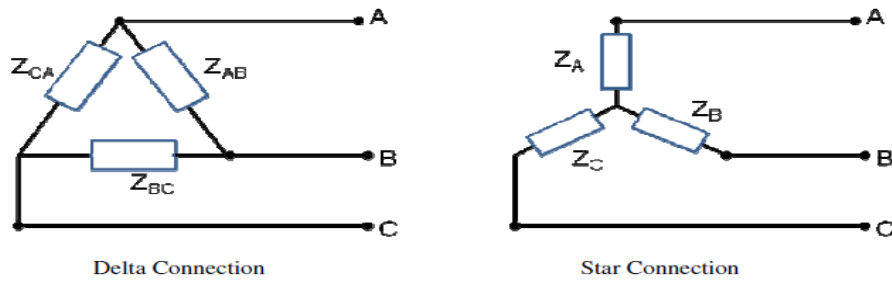

Fig:2.2.4 Balanced load [ Ref: Wikipedia].

**Star Connection: Relationship between line and phase values.**

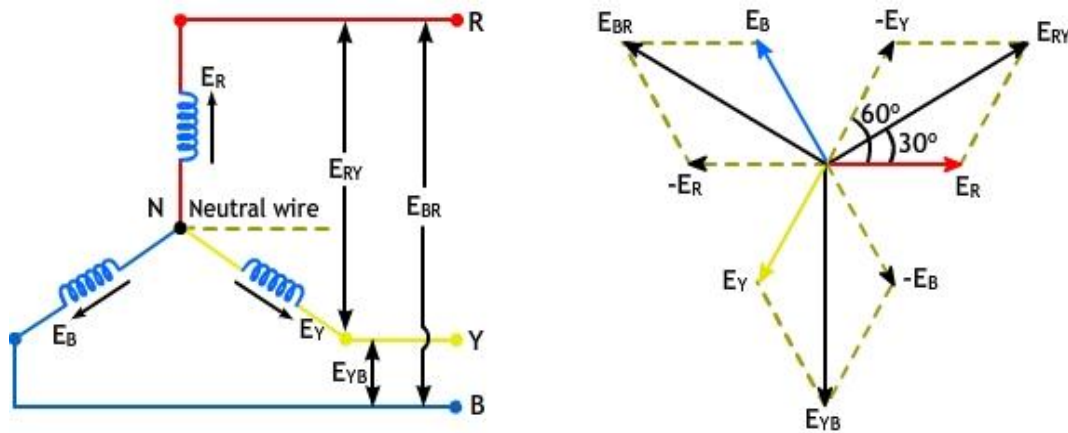

Fig:2.2.5 Star connected circuit [Ref: threephasepower.org]

The common point N at which similar ends are connected is called the **neutral point**.

The voltage between any line and the neutral point is called phase voltage; while the voltage between any two lines is called line voltage.

For example, the potential difference between outers R and Y or line voltage  $E_{RY}$ , is the vector difference of phase emf's  $E_R$  and  $E_Y$  or vector sum of phase emf's  $E_R$  and  $(-E_Y)$ .

$$\text{i.e., } E_{RY} = E_R - E_Y$$

As phase angle between vectors  $E_R$  and  $(-E_Y)$  is  $60^\circ$ ,

Therefore, from vector diagram shown in figure.

$$E_{RY} = \sqrt{E_R^2 + E_Y^2 + 2E_R E_Y \cos 60^\circ}$$

Let  $E_R = E_Y = E_B = E_P$  (phase voltage)

Then line voltage

$$\begin{aligned} E_{RY} &= \sqrt{E_P^2 + E_P^2 + (2 E_P E_P \times 0.5)} \\ &= \sqrt{3} E_P \end{aligned}$$

Similarly, potential difference between Y and B is

$$E_{YB} = E_Y - E_B = \sqrt{3} E_P$$

In a balanced star system,  $E_{RY}$ ,  $E_{YB}$  and  $E_{BR}$  are equal in magnitude and are called line voltages.

$$\therefore E_L = \sqrt{3} E_P$$

Since, in a star connected system, each line conductor is connected to a separate phase, the current flowing through the lines and phases are the same.

i.e., **Line current  $I_L$  = Phase current  $I_P$**

If the phase current has a phase difference of  $\phi$  with the phase voltage.

Power output per phase =  $E_P I_P \cos \phi$

Total power output,

$$\begin{aligned} P &= 3E_P I_P \cos \phi \\ &= 3(E_L/\sqrt{3}) I_P \cos \phi \\ &= \sqrt{3} E_L I_L \cos \phi \end{aligned}$$

**Mesh or Delta Connected System: Relationship between line and phase values.**

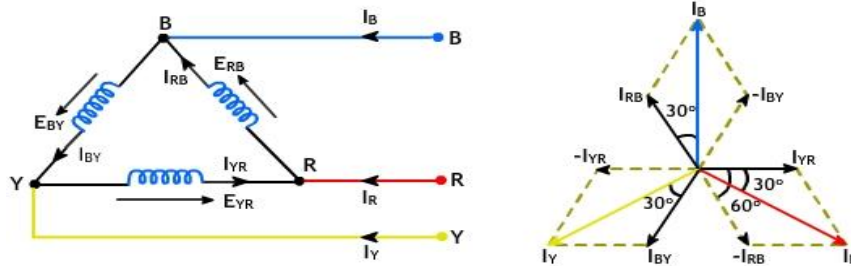

Fig:2.2.6 Delta connected circuit[Ref: threephasepower.org]

$I_R$ ,  $I_Y$  and  $I_B$  are line currents and  $I_{RB}$ ,  $I_{BY}$  and  $I_{YR}$  are phase currents .

Line current,  $I_R = I_{YR} - I_{RB}$

$$I_R = \sqrt{I_{YR}^2 + I_{RB}^2 + 2 I_{YR} I_{RB} \cos 60^\circ}$$

For a balanced load, the phase current in each winding is equal and let it be  $I_p$

$$\therefore \text{Line current, } I_R = \sqrt{I_p^2 + I_p^2 + 2 I_p I_p \times 0.5}$$

$$= \sqrt{3} I_p$$

Similarly, line current,  $I_Y = I_{BY} - I_{YR} = \sqrt{3} I_p$

and line current,  $I_B = I_{RB} - I_{BY} = \sqrt{3} I_p$

In a delta network, there is only one phase between any pair of lines, so the potential difference between the lines (line voltage) is equal to phase voltage.

$$E_L = E_p$$

Power output per phase =  $E_p I_p \cos \phi$ ,

Where  $\cos \phi$  is the power factor of the load.

Total power output,

$$\begin{aligned} P &= 3E_P I_P \cos \phi \\ &= 3 E_L(I_L/\sqrt{3}) \cos \phi \\ &= \sqrt{3} E_L I_L \cos \phi \end{aligned}$$

### The Power Triangle:

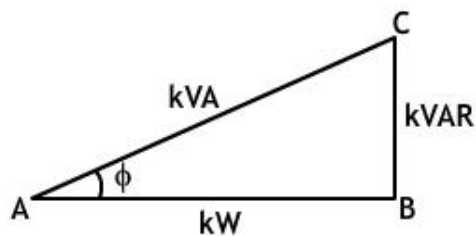

Fig:2.2.7 Power triangle [Ref: PMC]

In the figure,

$AB = \sqrt{3} E_L I_L \cos \phi$ , represents the real power in watts or kW.

$BC = \sqrt{3} E_L I_L \sin \phi$ , represents the reactive power in VAR or kVAR.

$AC = 3EI$ , represents the apparent power in VA or kVA.

$$i) (kVA)^2 = (kW)^2 + (kVAR)^2$$

ii) Circuit power factor,  $\cos \phi = \text{True power} / \text{Apparent power}$

$$iii) kVAR = kVA \sin \phi$$

$$= (kW / \cos \phi) \times \sin \phi$$

$$= kW \tan \phi$$

### Measurement of Power in 3-Phase Circuits:

In three circuits total three phase power is given by  $\sqrt{3} E_L I_L \cos \phi$ , in practice the problems in measuring three phase power occur as power factor for different type of load. And the power factor of induction motor and synchronous generators may vary with the load conditions, therefore it is difficult to calculate power. Hence it is necessary to use **wattmeter** which can sense the power factor and will give power in watts.

Wattmeter is a device which gives power reading, when connected in single phase or three phase system in watts.

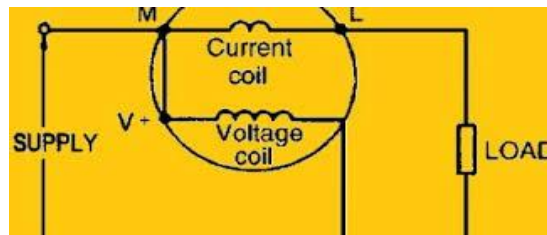

Fig:2.2.8 Single phase wattmeter[Ref: electrical basic projects.com]

It consists of two coils as shown in the circuit diagram fig 8.

- Current coil: Senses the current and always to be connected in series with the load.
- Potential coil: This is also called as pressure coil. This senses the voltage and always to be connected across the supply terminals.
- The terminologies used to denote current coil and pressure coil are ML – CV.
- M – From Mains for current coil
- L – To Load for current coil
- C – Common for voltage coil
- V- Voltage for voltage coil

Three phase power can be measured by using two single phase watt meter connected to any of the two phases, irrespective of the type (star or delta). Consider a balanced load of star type to which two watt meters are connected W1 and W2 as shown in the circuit diagram fig 10.

**Two Wattmeter Method – Balanced Load:**

In the case of balanced load, (where impedances of all the 3 phases are equal) we can find the power factor of the load from the two-wattmeter readings. Consider star-connected inductive load (figure 9) the vector diagram for which is given in figure10.

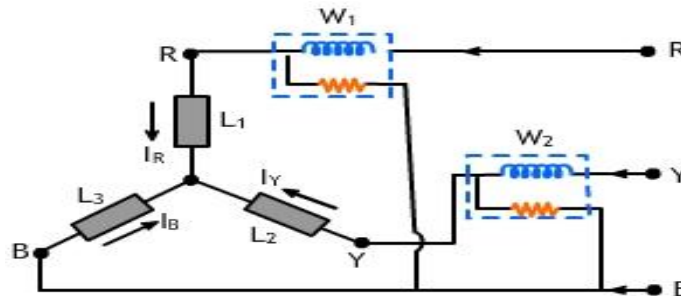

Fig:2.2.9 Two watt meter connected to star connected load.[Ref: threephasepower.org]

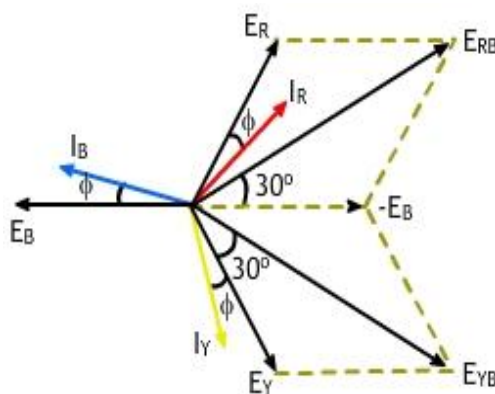

Fig:2.2.10 Vector diagram of line current and line voltage[Ref: threephasepower.org]

Current through wattmeter  $W_1$  is  $I_R$

The potential difference across the voltage coil of  $W_1$  is

$E_{RB} = E_R - E_B$  - vectorially

Reading of  $W_1 = I_R E_{RB} \cos(30^\circ - \phi)$

Similarly, current through  $W_2 = I_Y$  and potential difference across  $W_2 = E_{YB} = E_Y - E_B$

The angle between  $I_Y$  and  $E_{YB}$  is  $(30^\circ + \phi)$ .

Reading of  $W_2 = I_Y E_{YB} \cos (30^\circ + \phi)$

$E_{RB} = E_{YB} =$  Line voltage  $E_L$  and

$I_Y = I_R =$  Line current  $I_L$  (Since the load is balanced)

$W_1 = E_L I_L \cos (30^\circ - \phi)$  and  $W_2 = E_L I_L \cos (30^\circ + \phi)$

$$\begin{aligned} \therefore W_1 + W_2 &= \sqrt{3} E_L I_L \cos \phi \\ &= \text{Total power in the 3-phase load.} \end{aligned}$$

Thus, the total power absorbed in the 3-phase load is given by the sum of the two-wattmeter readings.

### Power Factor – Balanced 3-Phase Load:

**Case 1:** Lagging power factor

$$W_1 + W_2 = \sqrt{3} E_L I_L \cos \phi \quad \text{----- (i)}$$

Similarly,

$$W_1 - W_2 = E_L I_L \sin \phi \quad \text{----- (ii)}$$

Dividing equation (ii) by (i), we get

$$\tan \phi = \sqrt{3} (W_1 - W_2) / (W_1 + W_2) \quad \text{----- (iii)}$$

Once  $\tan \phi$  is known,  $\phi$  and hence power factor,  $\cos \phi$  can be found.

### Power Factor – Balanced 3-Phase Load:

**Case 2:** Leading power factor

$$W_1 = E_L I_L \cos (30^\circ + \phi) \text{ and}$$

$$W_2 = E_L I_L \cos (30^\circ - \phi)$$

$$\therefore W_1 + W_2 = \sqrt{3} E_L I_L \cos \phi$$

$$W_1 - W_2 = - E_L I_L \sin \phi$$

$$\therefore \tan \phi = - \sqrt{3} (W_1 - W_2) / (W_1 + W_2)$$

**Effect of power factor on wattmeter reading:**

**Case 1:** at  $\cos \phi = 0$

$$\phi = 90^\circ$$

$$W_1 = \frac{1}{2} E_L I_L$$

$$W_2 = -\frac{1}{2} E_L I_L$$

**Case 2 :** at  $\cos \phi = 0.5$

$$\phi = 60^\circ$$

$$W_1 = E_L I_L \cos 30^\circ$$

$$W_2 = 0$$

**Case 3 :** at  $\cos \phi = 1$

$$\phi = 0^\circ$$

$$W_1 = E_L I_L \cos 30^\circ$$

$$W_2 = E_L I_L \cos 30^\circ$$

**Numericals:**

1.The power in a three-phase system is measured by two watt meters. If the input power is 100kW and power factor is 0.66 (lag)

a) What will be the reading of each wattmeter?



b) For what power factor will one of the wattmeter read zero?

**Solution:**

$$a) P = 100 \text{ kW} = W_1 + W_2$$

$$\cos \phi = 0.66$$

$$\phi = 48.7^\circ$$

$$\tan \phi = \sqrt{3} \times (W_1 - W_2) / (W_1 + W_2)$$

Substituting the values in the above equation,

$$W_1 - W_2 = 65.7 \text{ kW}$$

$$W_1 + W_2 = 100 \text{ kW}$$

$$\therefore 2 W_1 = 165.7 \text{ kW}$$

$$\text{or } W_1 = 82.85 \text{ kW}$$

$$W_2 = \mathbf{17.15 \text{ kW}}$$

b) If  $W_2 = 0$ ,

$$\tan \phi = \sqrt{3}$$

$$\phi = 60^\circ$$

$$\cos \phi = \mathbf{0.5}$$

2. Two watt meters are connected to measure the input of a 15 HP, 50Hz, 3-phase induction motor at full load. The full load efficiency and power factor are 0.9 and 0.8 lag respectively. Find the readings of the watt meters.

**Solution:**

$$\text{Efficiency} = \text{Output} / \text{Input}$$

$$0.9 = (15 \times 735.5) / \text{Input}$$

$$\text{Input} = 12258.3 = W_1 + W_2 \quad \text{----- (1)}$$

$$\cos \phi = 0.8$$

$$\therefore \phi = 36.86$$

$$\tan \phi = \sqrt{3} \times (W_1 - W_2) / (W_1 + W_2)$$

$$0.75 = \sqrt{3} \times (W_1 - W_2) / 12258.3$$

$$W_1 - W_2 = 5308 \text{ W} \quad \text{----- (2)}$$

From (1) and (2)

$$W_1 = \mathbf{8783 \text{ W}}$$

$$W_2 = \mathbf{3476 \text{ W}}$$

3. Three identical impedances are connected in delta to a 3-phase supply of 400V. The line current is 35A, and the total power taken from the supply is 15kW. Calculate the resistance and inductance values of each impedances.

**Solution:**

Delta connection

$$V_L = 400 \text{ V} = V_{Ph}$$

$$P = 15 \text{ kW}$$

$$I_L = 35 \text{ A}$$

$$I_{Ph} = I_L / \sqrt{3}$$

$$= 35 / \sqrt{3} = 20.2 \text{ A}$$

$$Z_{Ph} = V_{Ph} / I_{Ph}$$

$$= 400 / 20.2$$

$$= \mathbf{19.8 \text{ ohms}}$$

We know that for 3-phase power

$$P = \sqrt{3} V_L I_L \cos \phi$$

$$15000 = \sqrt{3} \times 400 \times 35 \times \cos \phi$$

$$\cos \phi = 0.62$$

$$\phi = 51.68$$

$$\sin \phi = 0.78$$

$$R_{Ph} = Z \cos \phi = 19.8 \times 0.62 = \mathbf{12.3 \text{ ohms}}$$

$$X_{Ph} = Z \sin \phi = 19.8 \times 0.785 = \mathbf{15.54 \text{ ohms}}$$

4.A balanced star connected load of  $(3 + j4) \Omega$  impedance is connected to 400V, three phase supply. What is the real power consumed by the load?

**Solution:**

$$V_L = 400 \text{ V}$$

$$\text{impedance / phase} = Z = 3 + j4 = 5 \angle 53^\circ \Omega$$

In a star connected system,

Phase voltage

$$\therefore \text{Current in each phase} = \mathbf{46.02 \angle -53^\circ \text{ A}}$$

$$\therefore \text{Line current} = 46.02 \text{ A}$$

$$\therefore \text{Total power consumed in the load}$$

$$= \sqrt{3} V_L I_L \cos \phi$$

$$= \sqrt{3} \times 400 \times 46.02 \times \cos(-53^\circ)$$

$$= \mathbf{19188 \text{ W}}$$

**MODULE III(A)**  
**BASIC INSTRUMENTS**

**Basic Instruments:** The instruments which are designed to measure electrical quantities are called electrical measuring instruments.

**Classifications of measuring instruments:** The secondary measuring instruments are broadly classified into three types

1. Indicating instruments: it indicates the measuring value instantaneously by means of pointer moving over calibrated scale
2. Recording instruments: It records the measuring quantity by a pen moving over a paper for a period of time,
3. Integrating instruments: It not only measures and records the measuring quantity. But also register the measured quantity which can be access by any time.

Operating principles of measuring instruments: various operating principles by which an instrument can measures the electrical quantities are. Magnetic effect, thermal effects, electromagnetic effects, chemical effects, electrostatic effects etc.

**Essential features** of measuring instruments are high sensitivity, fast response, high flexibility, low weight, low power consumption and high degree of reliability.

**Permanent magnet moving coil instrument:** it is the most accurate type of D.C measuring instrument. Its working principle is same as that of d'Arsonval type of galvanometer.

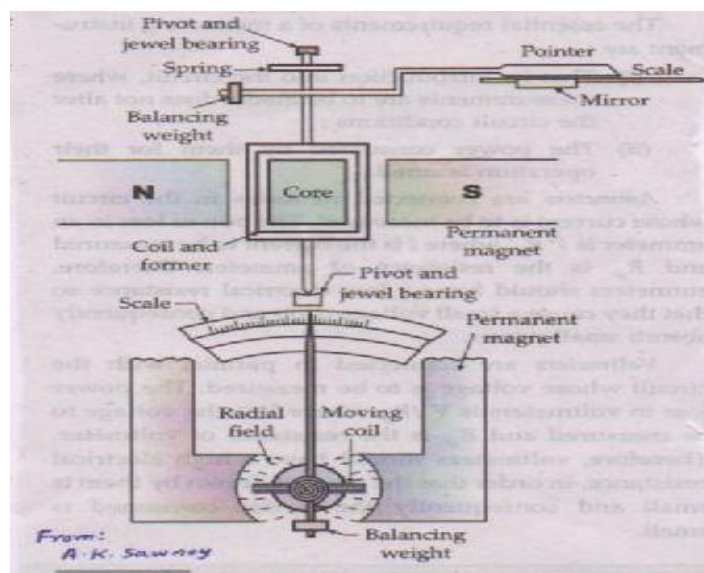

Fig:3.1.1. Permanent magnet moving coil instrument[Ref: A.K.Sawhney]

**Construction:** It mainly consist of moving coil, magnetic system, control system, damping system, pointer and scale as show in the above figure. A light rectangular coil of more turns is wound on a light aluminum former and is pivoted at the center of two powerful permanent magnetic polls such that its sides are in the air gap between the polls of permanent magnet and soft iron cylinder. The cylindrical iron core is mounted between the two poles of the magnet provides a narrow air gape in which rectangular coil is placed. The spring provides control torque. The system is provided by electromagnetic damping.

**Operation:** When a current is passed through the coil it produce magnetic flux which interact with the main flux there by deflecting torque is produce similar to the D C motor. The magnitude of deflecting I moving coil is proportional to the current flows in the coil. At study stage condition deflecting torque is equal and opposite to control torque where pointer takes position on the moving scale. From that position half pointer the magnitude of current can be measured.

**Basic Ammeter circuit:**

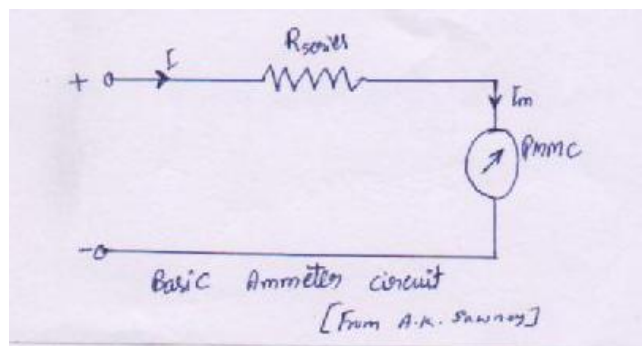

Fig: 3.1.2. Ammeter circuit.[Ref: A.K Sawhney]

Basic ammeter circuit consists of PMMC meter coil in series with high value resistor. When ammeter is used to measure the current. High voltage drop occurs at series resistor and small voltage is available across the ammeter. Now scale of the meter is calibrated to measure the main current in terms of current in the meter proportional to voltage.

**Basic voltmeter circuit:**

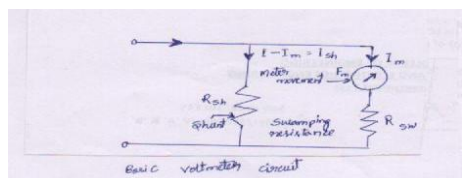

Fig:3.1.3. Voltmeter circuit[Ref: A.K Sawhney]

**Basic voltmeter circuit:** It consists of PMMC meter coil in parallel with low value resistor. When voltmeter is used to measure the voltage more current is diverted through the shunt resistor and small value of current pass through the meter. Now the voltmeter pointer deflects over the calibrated scale proportional to voltage drop across the meter.

**1. Dynamometer type wattmeter:**

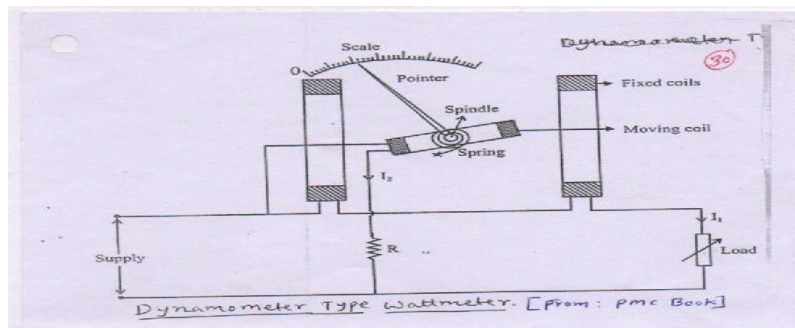

Fig:3.1.4. Dynamometer type wattmeter[Ref:PMC]

**Construction:** It consists of two identical fixed coils carries line current connected in series with supply and load. IN between the fixed coils a moving coil is placed which connected in parallel with the supply, so that it carries the current proportional to supply voltage. A high value resistor R is connected in series with moving coil to limit the current to safer value. Moving coil is provided with control torque by spring and air function damping is also provided.

**Operation:** when supply is connected to load through dynamo meter type watt meter then the fluxes produced by the fixed coils interact with the flux produced by the moving coil there by deflection torque is experienced by the moving coil. A pointer attached to moving coil taken its position on the power scale where deflecting torque is equal and opposite to control torque and measures the power.

**Induction type Energy meter:**

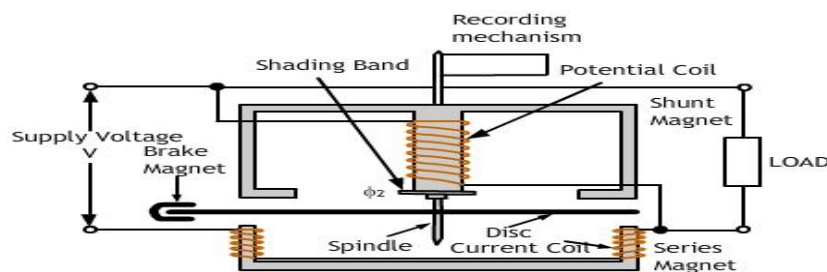

Fig:3.1.5. Induction type Energy meter[Ref: DSI ppt]

**Construction:**

It mainly consists of: 1. Driving system 2. Moving system 3. Braking system 4. Recording system.

1. Driving system: It has two electromagnets namely series magnet and shunt magnet. A coil of thick wire of few turns are wound on legs of series electromagnetic core connected in series with supply and load which carries line current.

A coil of this wire and large number of turns are wound on the central limb of shunt electromagnet. This coil carries the current proportional to supply voltage since it is connected parallel with supply. A copper shading band circuted copper rings are provided on control limb of shunt magnet to obtain the current in shunt coil lag behind the apply voltage by 90degree.

2. Moving system; It consist of light weight aluminum disc mounted on the spindle supported by Jewel bearings. The disc is set to rotate in the air gap between the series and shunt electromagnet. Since control torque is not provided to moving disc. Disc will rotate through an angle of 360degree.

3. Braking system: A adjustable brake magnet is placed near the edge of the aluminum disc which induce an emf in the disc which circulate the eddy current in the disc in such a direction to produce the torque opposite to rotation of disc. That means it provides eddy current damping force to moving system.

4. Recording mechanism: It records a number of revolutions made by the disc during the period of energy consumption by the load.

**Operation:** When the supply is connected to load through the energy meter. The flux produced by the series electromagnet and shunt electro magnet interacts over the disc which induced an emf and eddy current in the disc. According to Lenz's law the eddy current flows in such a direction which oppose cause producing it induced voltage in the disc. Disc is subjected to rotation power consumed by the load is number of disc rotation and Energy power time Total number of disc revolution in 't' seconds directly proportional to energy consumption by the load.

MODULE III(B)

**DOMESTIC WIRING**

**Service mains:** The conductors which bring electrical energy from the nearest pole carrying the secondary distribution system to the consumers premises are known as Service mains. For all domestic purposes only single phase supply is required. There are 2 types namely: Over head service mains and Underground service mains.

**Over head service mains:** In this, the conductors from the pole to the meter board run above the ground level at a reasonably good height providing clearance from the adjacent buildings. Aluminum core steel reinforced or hard drawn copper conductors are used as service mains. Their size depends on load of the consumer.

**Underground service mains:** This is provided if the load of the consumer is more than 25kW. In this overhead connections can not be given and this improves the beauty of the building.

**Meter board and Distribution board:**

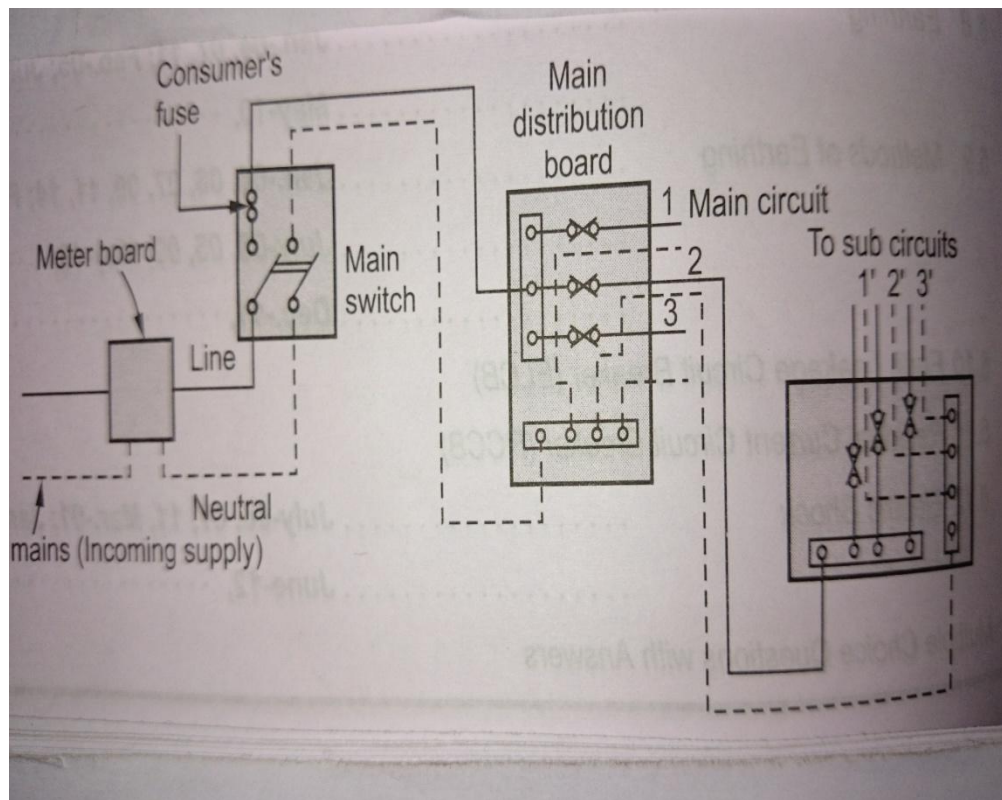

Fig: 3.2.1. Meter board & distribution board. [Ref: Basic Electrical Engineering text book, Bakshi]



Supply is taken through service mains and connected to the input terminals of the energy meter which is fixed in wooden box. The wooden box is known as meter board. This consists of a fuse which is a safety device during over loads or short circuits. The energy meter is provided by the electric supply company. The energy meter must be installed at a place which is easily accessible by meter readers. The main switch is used to switch on and off the supply to the building. This is provided next to the energy meter and output terminals of the energy meter are connected as input terminals to main switch. The output terminals of the energy meter are connected as input terminals of main switch and this is connected to distribution board. The main switch is usually an iron clad double pole [ICDP] switch. The main switch is fixed inside the distribution board itself. The distribution board is a rectangular box which consists of 2 bus bars fixed. One neutral bus bar and other phase bus bar. Domestic load is distributed to various sub circuits from distribution board.

## Systems of wiring:

### 1.Cleat wiring:

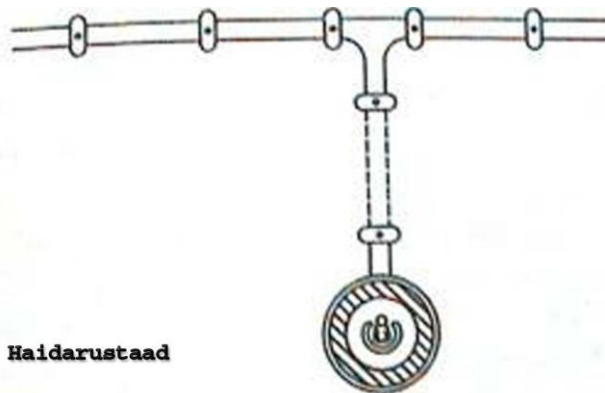

Fig: 3.2.2. Cleat wiring.[ Ref: [www.google.com](http://www.google.com)]

In this type of wiring wires run b/w porcelain cleats which are fixed by screwing. The wires are made of VIR or PVC. The porcelain cleats used are of two halves one base and other cap. Ax distance b/w the cleats should not exceed 60cm so that wires will not come into contact either with wall or each other.

Advantages: Low cost and easy maintenance, requires less labour and workmanship.

Disadvantages: Not suitable for wet and damp areas, does not provide good appearance.

Applications: Preferred for temporary installations where the place is dry.

## 2. Wooden casing and capping wiring:

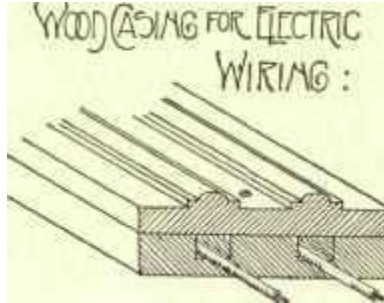

Fig: 3.2.3. Wooden casing and capping wiring [Ref: [www.google.com](http://www.google.com)]

When the wires/ cables used in wiring needs protection this system is used. These have wooden casing with grooves covered by capping. Cables are made of VIR or PVC. Length of casing and capping should be 2.5- 3 meters.

Advantages: Good appearance, low quality wires can be used, easy to install and rewire.

Disadvantages: Cannot be used in wet and damp places, requires better workman ship.

Applications: Preferred for low voltage.

## 3. Conduit wiring:

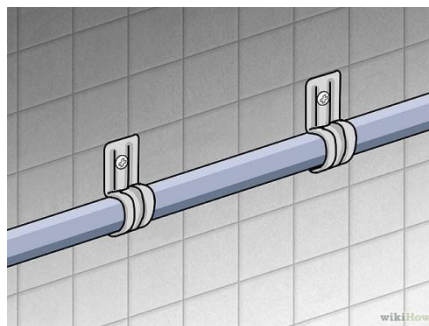

Fig: 3.2.4. Conduit wiring [Ref: [www.google.com](http://www.google.com)]

Conduit is buried under the wall or ceiling. PVC conduit is popularly is used as it requires less time to install and cheaper in cost. The conduit is fixed by means of J hooks, fully protected mechanical injury. Does not affect appearance. The channels are provided in the wall before plastering and then conduit is fixed in the channel by the hooks.

**Two Way and Three Way Control of Lamps:**

Two way control of the lamp. If we want to control a lamp from more than one point (stair case) say from two places then it is called two way control. Similarly we can control a lamp from three places under certain circumstances and is called as three way control.

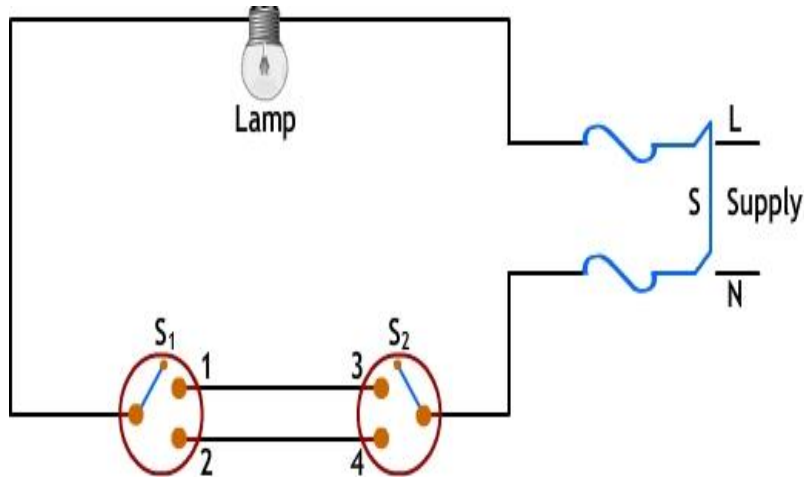
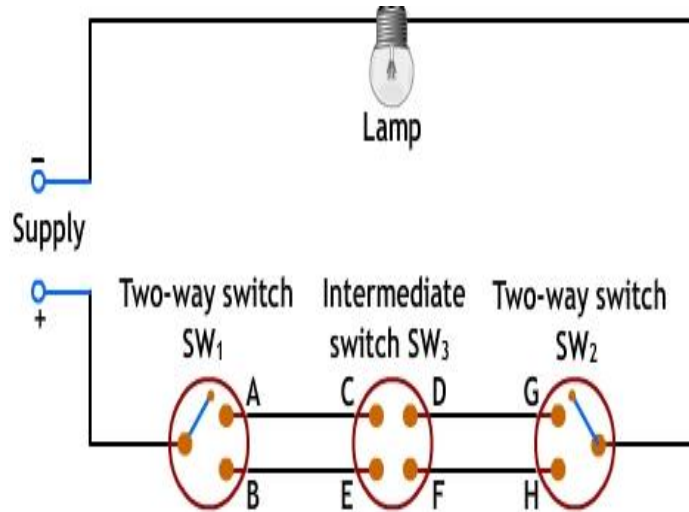

Fig: 3.2.5. Two way control of lamps [Ref: DSI ppt]

The operation of the circuit is explained in the following table

Position of $S_1$	Position of $S_2$	Condition of lamp
1	3	ON
1	4	OFF
2	3	OFF
2	4	ON

**The Wiring Diagram of Three Way Control of the Lamp with OC – Open:**



*Fig:3.2.6. Three Way Control of the Lamp[Ref: DSI ppt]*

**Three way control:** Figure shows the circuit to control a lamp at three different points.  $SW_1$  and  $SW_2$  are single pole double throw switches (SPDT).  $SW_3$  is a double pole double throw switch (DPDT). The operation of the circuit is given in table.

$SW_1$	$SW_2$	$SW_3$	State of Lamp
A	G	CD, EF	ON
A	H	CD, EF	OFF

B	G	CD, EF	OFF
B	H	CD, EF	ON
A	G	CF, ED	OFF
A	H	CF, ED	ON
B	G	CF, ED	ON
B	H	CF, ED	OFF

**Protective Devices:**

Protection for electrical installation must be provided in the event of faults such as short circuit, overload and earth faults. The protective circuit or device must be fast acting and must be able to isolate the faulty part of the circuit immediately. It also helps in isolating only required part of the circuit without affecting the remaining circuit during maintenance.

The following devices are usually used to provide the necessary protection:

- Fuses
- Relays
- Miniature circuit breakers (MCB)
- Earth leakage circuit breakers (ELCB)

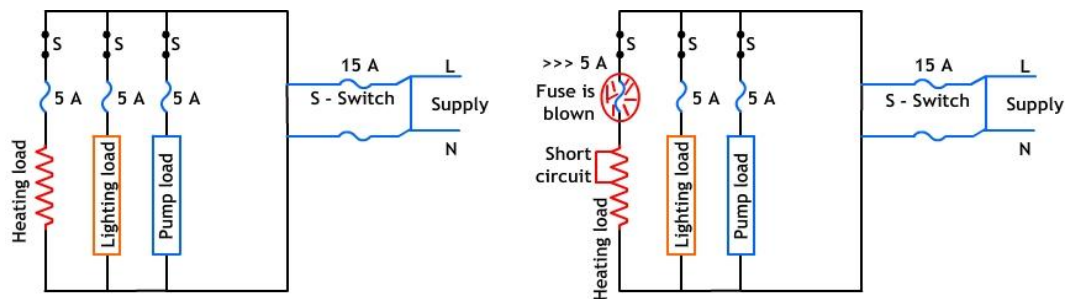

Fig:3.2.6.Connection of fuse[Ref DSI ppt]

In case of a short circuit or a fault the current increases beyond the rated current. This results in the melting of the conductor. This may cause a fire. Hence it is necessary to cut off the supply to the circuit. This is done by using a fuse. Fuse consists of a wire made of copper or lead tin alloy fixed to a porcelain base. The fuse wire is connected in series between the supply and the circuit. The thickness of the fuse wire depends upon the rated current of the circuit. When the circuit current exceeds the rated current, the fuse wire melts, resulting into the disconnection of the supply to the circuit. Thus any damage to the circuit is prevented. The material used for fuse wires must have the following characteristics : Low melting point, Low ohmic losses, High conductivity, Lower rate of deterioration.

### Terms Related with Fuses:

**1.Rated current:** It is the maximum current, which a fuse can carry without undue heating or melting. It depends on the following factors: Permissible temperature rise of the contacts of the fuse holder and the fuse material, Degree of deterioration due to oxidation

**2.Fusing current:** The minimum current at which the fuse melts is known as the fusing current. It depends on the material characteristics, length, diameter, cross-sectional area of the fuse element and the type of enclosure used.

**3.Fusing Factor:** It is the ratio of the minimum fusing current to the rated current. It is always greater than unity.

### Miniature circuit breakers[MCB's]:

These are electrical switching devices which are used to protect the electrical equipment and circuits under over load conditions. Circuit breakers used in residential , commercial installations at low voltages are referred as MCB's. These are single pole breakers and are installed in a cabinet. It is also use for Tripping during ground faults.

## **Features of MCB:**

Operation is very fast, No tripping circuit is necessary operation is automatic, Provides protection against over load and short circuit without noise, Can be reset very quickly after correcting the fault, Current rating is from 0.5A to 63A, Voltage rating 240V for single phase 415V for three phase, 220V for DC.

## **Electric shock:**

When a person comes in contact with the live wire supplying electricity, he receives a shock. The severity of the shock received depends on the voltage of the wire and the body resistance of the person. The max.current a human body can withstand is 30mA. If the body is totally wet, the body resistance is 1000 ohms, if it is dry, it is about 5000 ohms. Mild shocks produce nervousness. The damage caused due to an electric shock depends the voltage, the current, person's health etc.

## **Precautions:**

Insulation of the conductors used must be proper, Meggar tests should be conducted, insulation must be checked, earth connection should be always maintained in proper condition, use rubber soled shoes and gloves while working, never touch the two different terminals at the same time, sockets should be fixed at a height beyond reach of children.

## **Earthing:**

Earthing is connecting the exposed metal parts of the appliances to ground (or earth) by using a conductor of very low resistance. The earthing procedure is as follows;

- The earthing wire brought out from the equipment is joined to the earthing electrode through the earthing terminal of the 3 pin socket.
- The earthing electrode may be a galvanized iron (GI) pipe or a rod or a plate or may be a strip.
- A pit is dug (in the ground) of size 30 cm x 30 cm for at least 2 m depth below the ground level.
- This pit is half filled with a layer of common salt and charcoal as shown in figure.
- Above this the remaining depth is filled by soil till ground level.
- The earthing electrode is embedded in a pit.

The two types of earthing are: Plate earthing and Pipe earthing.

**Plate Earthing:**

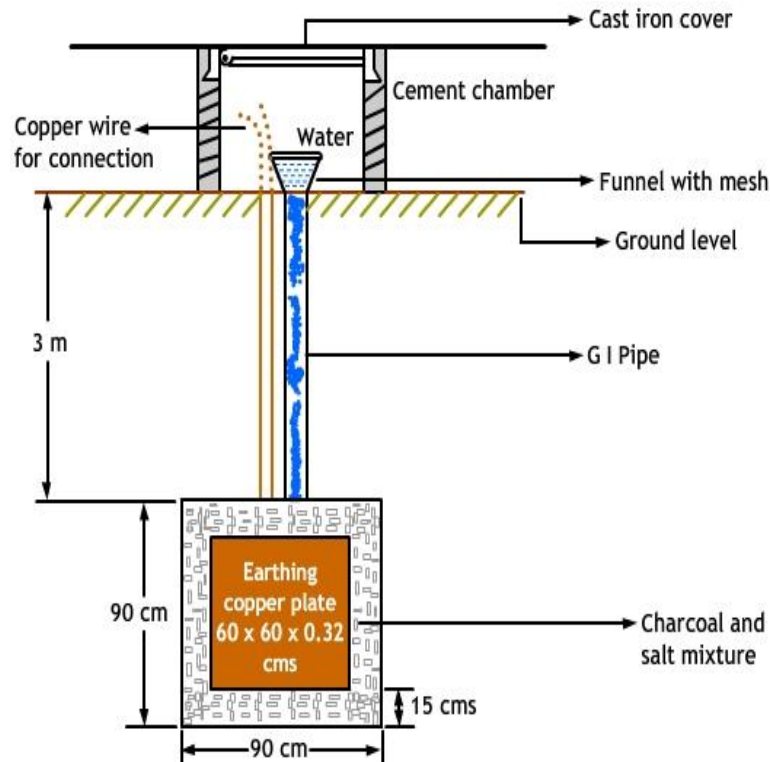

Fig:3.2.7. Plate earthing[Ref: DSI ppt]

- In this method a copper plate of 60 cm x 60 cm x 3.18 cm or a GI plate of the size 60 cm x 60 cm x 6.35 cm is used for earthing.
- The plate is placed vertically down inside the ground at a depth of 3 m and is embedded in alternate layers of coal and salt for a thickness of 15 cm.
- In addition, water is poured for keeping the earth electrode resistance value well below a maximum of 5 ohms.
- The earth wire is securely bolted to the earth plate.
- A cement masonry chamber is built with a cast iron cover for easy regular maintenance.

Earthing efficiency increases with increase of plate area and depth of embedding. The disadvantage is that discontinuity of earth plate can not be observed.



**Pipe Earthing:**

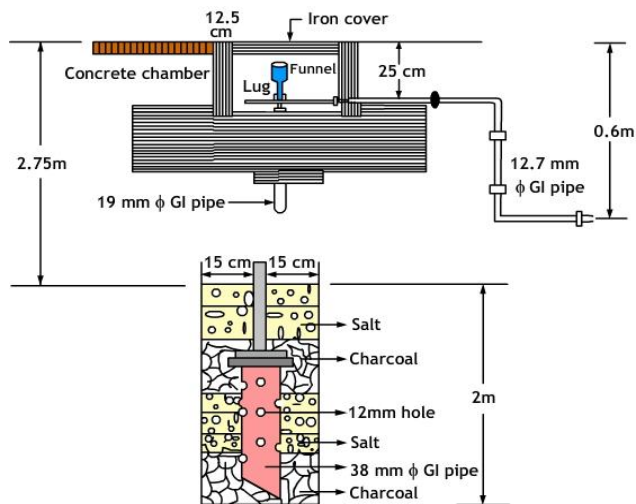

Fig: 3.2.8. Pipe earthing. [Ref DSI ppt]

- Earth electrode made of galvanized iron (GI) pipe of 38 mm in diameter and length of 2 m (depending on the current) with 12 mm holes on the surface, is placed upright at a depth of 4.75 m in a permanently wet ground.
- To keep the value of the earth resistance at the desired level, the area (15 cms) surrounding the GI pipe is filled with a mixture of salt and coal.
- The efficiency of the earthing system is improved by pouring water through the funnel periodically.
- The GI earth wires of sufficient cross-sectional area are run through a 12.7 mm diameter pipe at 60 cms below from the 19mm diameter pipe and secured tightly at the top as shown in the figure.

The disadvantage is embedded pipe length has to be increased sufficiently with high order specific resistivity.

**MODULE-IV(A)**

**DC MACHINES**

D C machines are electrical machines which deal with the conversion of one form of energy to another. The process of conversion is called as electromechanical energy conversion.

**D.C Generator:-**A D.C machine which converts mechanical energy into electrical energy is called a d.c generator.

**D.C Motor:-**A D.C machine which converts electrical energy into mechanical energy is known as a d.c motor.

**Basic principle of D.C machine:** - A D.C machine works on the principle of Faradays laws of electromagnetic induction.

When a conductor moves in a magnetic field, voltage is induced in the conductor. (Generator action)

When a current carrying conductor placed in a magnetic field, the conductor experiences a mechanical force (Motor action)

**Basic principle of D.C machine as a generator:** - Conductor is moved in a magnetic field such that it cuts across lines of flux, dynamically induced e.m.f is produced.

The magnitude of this induced e.m.f in the conductor is given by the equation

$$E=Blv\sin\theta$$

Where, l=length of the portion of the conductor in the magnetic field

v= velocity of the conductor

B=magnetic flux density

$\theta$  = Angle between direction of movement of the conductor in the magnetic field and the direction of magnetic flux

The e.m.f induced in the conductor causes a current to flow in the conductor if the circuit is closed. Thus, electrical power develops in the conductor. If the conductor does not move or if it is moved parallel to the lines of flux, no e.m.f induced in it, and hence no power is generated. Hence it is clear that, for generation of e.m.f there should be relative motion between the conductor and magnetic field.

For the generating action must have the following requirements

- i) The conductor or coil
- ii) The flux
- iii) The relative motion between the conductor and flux

The direction of the induced e.m.f is given by Fleming's right hand rule

**Fleming's right-hand rule (for generators):-** shows the direction of induced e.m.f(current) when a conductor moves in a magnetic field.

The right hand is held with the thumb, first finger and second finger mutually perpendicular to each other (at right angles)

- The Thumb represents the direction of Motion of the conductor
- First finger represents the direction of the Field or Flux. (north to south)
- The Second finger represents the direction of the induced or generated Current (the direction of the induced current or e.m.f will be the direction of conventional current; from positive to negative).

### **Classification of Generators:-**

Generators are usually classified according to the way in which their fields are excited. The field windings provide the excitation necessary to set up the magnetic fields in the machine. There are various types of field windings that can be used in the generator or motor circuit. In addition to

the following field winding types, permanent magnet fields are used on some smaller DC products. Generators may be divided in to

- (a) Separately-excited generators and
- (b) Self-excited generators

(a) **Separately-excited generators** are those whose field magnets are energized from an independent external source of DC current

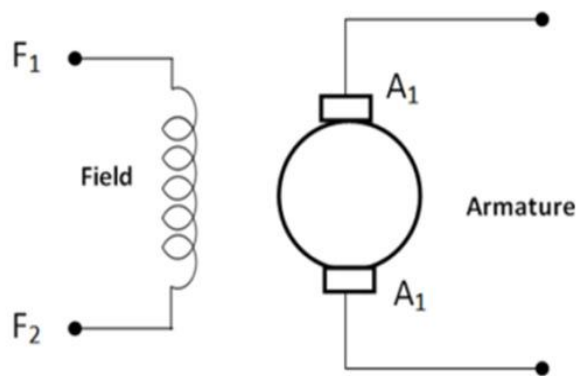

**Fig: Separately-excited generator**

Armature current  $I_a = I_L$

Terminal voltage  $V = E_g - I_a R_a$  volts

Power developed  $P = E_g I_a$  watts

Power delivered to the load  $= E_g I_a - I_a^2 R_a = I_a (E_g - I_a R_a) = V I_a$  watt

(b) **Self-excited generators** are those whose field magnets are energized by the current produced by the generators themselves. Due to residual magnetism, there is always present some flux in the poles. When the armature is rotated, some e.m.f and hence some induced current is produced which is partly or fully passed through the field coils thereby strengthening the residual pole flux.

Self-excited generators are classed according to the type of field connection they use.

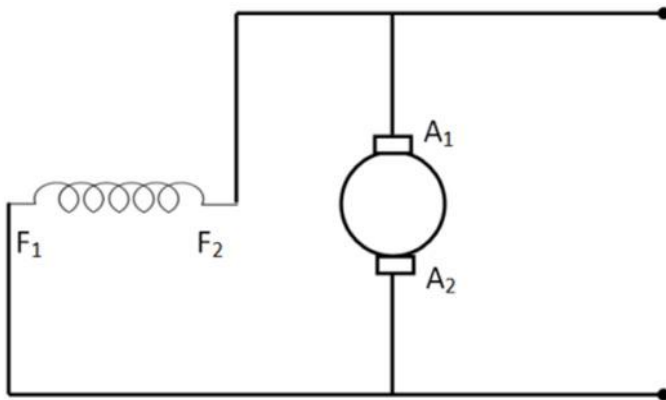

**Fig: Self-excited generators**

There are three general types of field connections.

(a) Series-Wound,

(b) Shunt- Wound (parallel),

(c) Compound- Wound

Compound-wound generators are further classified as cumulative-compound and differential-compound.

**Series-wound generator:** - In the series-wound generator, shown in figure, the field windings are connected in series with the armature. Current that flows in the armature flows through the external circuit and through the field windings. The external circuit connected to the generator is called load circuit.

A series-wound generator uses very low resistance field coils, which consist of a few turns of large diameter wire.

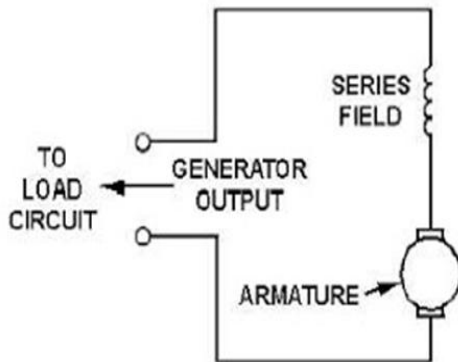

**Fig: Series-wound generator**

The voltage output increases as the load circuit starts drawing more current. Under low-load current conditions, the current that flows in the load and through the generator is small. Since small current means that a small magnetic field is set up by the field poles, only a small voltage is induced in the armature. If the resistance of the load decreases, the load current increases. Under this condition, more current flows through the field. This increases the magnetic field and increases the output voltage. A series-wound dc generator has the characteristic that the output voltage varies with load current. This is undesirable in most applications. For this reason, this type of generator is rarely used in everyday practice.

$$\text{Armature current } I_a = I_{se} = I_L = I$$

$$\text{Terminal voltage } V = E_g - I(R_a + R_{se})$$

$$\text{Power developed } P = E_g I_a$$

$$\text{Power delivered to the load} = E_g I_a - I^2(R_a + R_{se}) = I[E_g - I(R_a + R_{se})] = VI$$

**Shunt wound:** - In this field winding is connected in parallel with the armature conductors and have the full voltage of the generator applied across them. The field coils consist of many turns of small wire. They are connected in parallel with the load. In other words, they are connected across the output voltage of the armature.

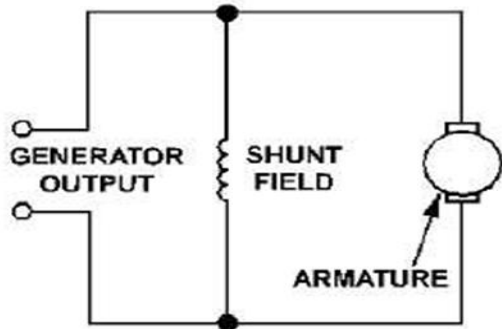

**Fig: Shunt wound**

Current in the field windings of a shunt-wound generator is independent of the load current (currents in parallel branches are independent of each other). Since field current, and therefore field strength, is not affected by load current, the output voltage remains more nearly constant than does the output voltage of the series-wound generator.

In actual use, the output voltage in a dc shunt-wound generator varies inversely as load current varies. The output voltage decreases as load current increases because the voltage drop across the armature resistance increases ( $E = IR$ ).

In a series-wound generator, output voltage varies directly with load current. In the shunt-wound generator, output voltage varies inversely with load current. A combination of the two types can overcome the disadvantages of both. This combination of windings is called the compound-wound dc generator.

$$\text{Armature current } I_a = I_L + I_{sh}$$

$$\text{Shunt field current } I_{sh} = (V/R_{sh})$$

$$\text{Terminal voltage } V = I_{sh} R_{sh}$$

$$\text{Power delivered } P = E_g I_a$$

$$\text{Power given to the load } = VI_L$$

**Compound-wound generator:-**

Compound-wound generators have a series-field winding in addition to a shunt-field winding, as shown in fig. The shunt and series windings are wound on the same pole pieces. They can be either short-shunt or long shunt as shown in figures. In a compound generator, the shunt field is stronger than the series field. When series field aids the shunt field, generator is said to be commutatively-compounded. On the other hand if series field opposes the shunt field, the generator is said to be differentially compounded.

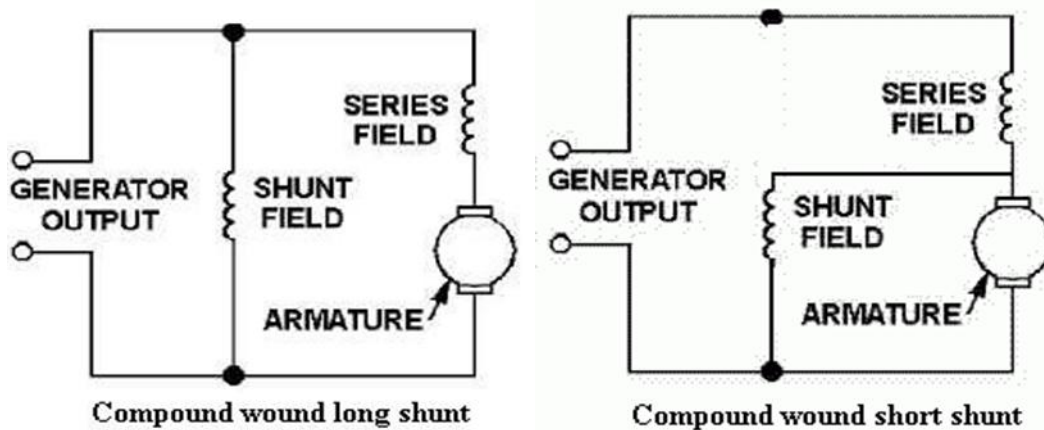

In the compound-wound generator when load current increases, the armature voltage decreases just as in the shunt-wound generator. This causes the voltage applied to the shunt-field winding to decrease, which results in a decrease in the magnetic field. This same increase in load current, since it flows through the series winding, causes an increase in the magnetic field produced by that winding.

By proportioning the two fields so that the decrease in the shunt field is just compensated by the increase in the series field, the output voltage remains constant. This is shown in figure, which shows the voltage characteristics of the series-, shunt-, and compound-wound generators. As you can see, by proportioning the effects of the two fields (series and shunt), a compound-wound generator provides a constant output voltage under varying load conditions. Actual curves are seldom, if ever, as perfect as shown.



**Short shunt compound wound generator:-**

Series field current  $I_{se}=I_L$

Shunt field current  $I_{sh}=(V+I_{se} R_{se})/R_{sh}$

Terminal voltage  $V=E_g-I_a R_a-I_{se} R_{se}$

Power delivered  $P=E_g I_g$

Power given to the load  $=VI_L$

**Long shunt compound wound generator:-**

Series field current  $I_{se}=I_L=I_a=I_{sh}+I_L$

Shunt field current  $I_{sh}=(V/R_{sh})$

Terminal voltage  $V=E_g-I_a(R_a+R_{se})$

Power delivered  $P=E_g I_g$

Power given to the load  $=VI_L$

**Construction**

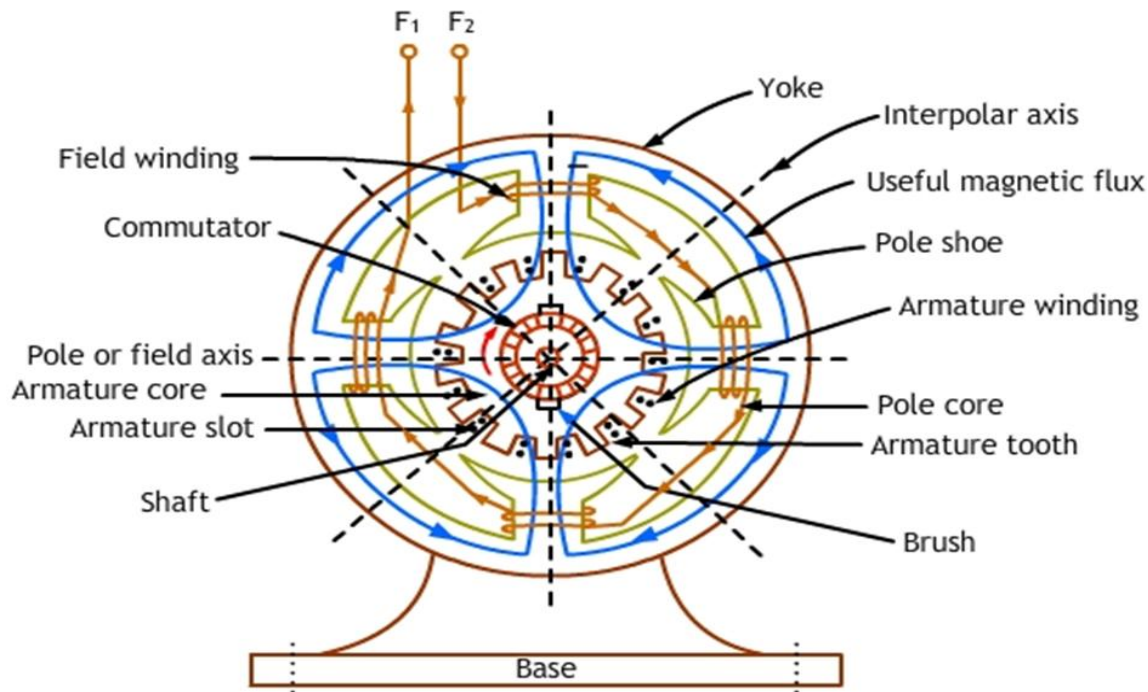

**Fig: DC Generator**

**Yoke:** The outer frame or yoke serves double purpose: (i) It provides mechanical support for the poles and acts as a protecting cover for the whole machine. (ii) It carries the magnetic flux produced by the poles. In small generators where cheapness rather than weight is the main consideration, yokes are made of cast iron. But for large machines usually cast steel or rolled steel is employed.

**Pole Cores and Pole Shoes:** The field magnets consist of pole cores and pole shoes. The pole shoes serve two purposes: (i) They spread out the flux in the air gap and also, being of larger cross-section, reduce the reluctance of the magnetic path. (ii) They support the exciting coils (or field coils) as shown below.

**Pole Coils:** The field coils or pole coils, which consist of copper wire or strip, are former-wound for the correct dimension. Then, the former is removed and wound coil is put into place over the core. When current is passed through these coils, they electro magnetize the poles which produce the necessary flux that is cut by revolving armature conductors.

**Armature Core:** It houses the armature conductors or coils and causes them to rotate and hence cut the magnetic flux of the field magnets. In addition to this, its most important function is to provide a path of very low reluctance to the flux through the armature from a N-pole to a S-pole. It is cylindrical or drum-shaped and is built up of usually circular sheet steel discs or laminations approximately 0.5 mm thick. The slots are either die-cut or punched on the outer periphery of the disc and the keyway is located on the inner diameter as shown. In small machines, the armature stampings are keyed directly to the shaft. Usually, these laminations are perforated for air ducts which permit axial flow of air through the armature for cooling purposes. The purpose of using laminations is to reduce the loss due to eddy currents. Thinner the laminations, greater is the resistance offered to the induced emf, smaller the current and hence lesser the  $I^2 R$  loss in the core.

**Armature Windings:** The armature windings are usually former-wound. These are first wound in the form of flat rectangular coils and are then pulled into their proper shape in a coil puller. Various conductors of the coils are insulated from each other. The conductors are placed in the armature slots which are lined with tough insulating material. This slot insulation is folded over above the armature conductors placed in the slot and is secured in place by special hard wooden or fiber wedges.

**Commutator:** The functions of the commutator are to facilitate collection of current from the armature conductors, and to convert the alternating current induced in the armature conductors into unidirectional current in the external load circuit. It is of cylindrical structure and is built up of wedge-shaped segments of high-conductivity hard-drawn or drop forged copper. These segments are insulated from each other by thin layers of mica. The number of segments is equal to the number of armature coils. Each commutator segment is connected to the armature conductor by means of a copper lug or riser. To prevent them from flying out under the action of centrifugal forces, the segments have V-grooves, these grooves being insulated by conical micanite rings.

**Brushes and Bearings:** The brushes, whose function is to collect current from commutator, are usually made of carbon or graphite and are in the shape of a rectangular block. These brushes are

housed in brush-holders, the brush-holder is mounted on a spindle and the brushes can slide in the rectangular box open at both ends. The brushes are made to bear down on the commutator by a spring. A flexible copper pigtail mounted at the top of the brush conveys current from the brushes to the holder. The number of brushes per spindle depends on the magnitude of the current to be collected from the commutator.

Because of their reliability, ball-bearings are frequently employed, though for heavy duties, roller bearings are preferable. The ball and rollers are generally packed in hard oil for quieter operation and for reduced bearing wear, sleeve bearings are used which are lubricated by ring oilers fed from oil reservoir in the bearing bracket.

### **E.M.F Equation of DC Generator:**

Let,  $\phi$  = Flux / pole in webers

Change in flux  $d\phi = P \phi$  webers

$Z$  = Total number armature conductors

= Number of slots x Number of conductors per slot

$P$  = Number of poles

$A$  = Number of parallel paths in the armature.

$N$  = Rotational speed of armature in revolutions per minute (r.p.m)

Time taken to complete one revolution =  $60/N$  sec.

$E$  = e.m.f induced / parallel path in armature.

By Faraday's law

$$\text{E.M.F generated per conductor} = \frac{d\phi}{dt} = \frac{\phi PN}{60 \text{ volts}}$$

Number of armature conductors per parallel path =  $\frac{Z}{A}$

$E_g$  = e. m. f generated per conductor  $\times$  Number of conductors in each parallel path

$$E_g = \left( \frac{\phi PN}{60} \right) \times \frac{Z}{A} \text{ volts} \quad \dots\dots\dots(i)$$

For a Simplex Wave-Wound Generator

Number of parallel paths  $A = 2$

$$E_g = \frac{\phi PN \cdot \left( \frac{Z}{2} \right)}{60} = \frac{\phi ZPN}{120} \text{ volts}$$

For Simplex Lap-Wound Generator:

Number of parallel paths,  $A = P$

Equation (i) becomes

$$E_g = \frac{\phi PN \cdot \left( \frac{Z}{P} \right)}{60} = \frac{\phi ZN}{60} \text{ volts}$$

**Armature Reaction**

The action of magnetic field set up by armature current on the distribution of flux under main poles of a DC machine is called the armature reaction.

When the armature of a DC machines carries current, the distributed armature winding produces its own mmf. The machine air gap is now acted upon by the resultant mmf distribution caused by the interaction of field ampere turns ( $AT_f$ ) and armature ampere turns ( $AT_a$ ). As a result the air gap flux density gets distorted.

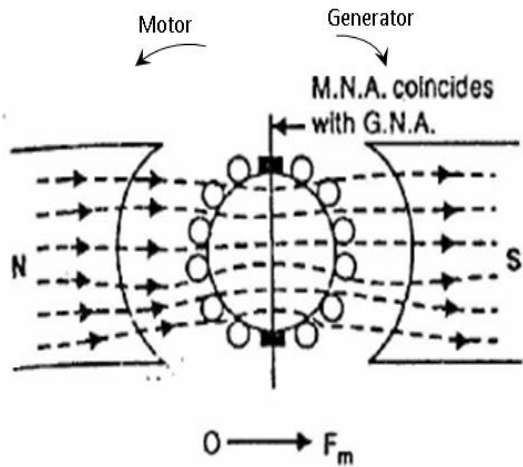

Figure (a)

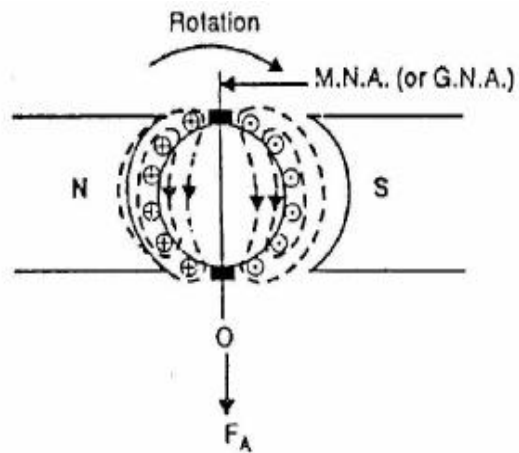

Figure (b)

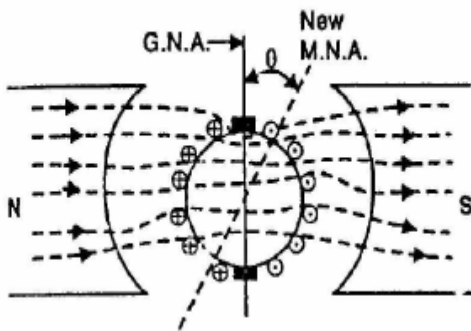

Figure (c)

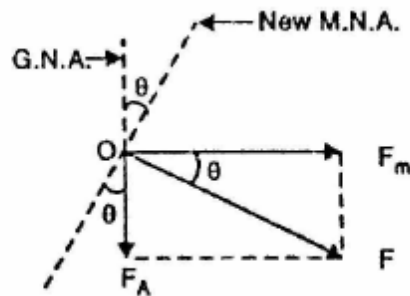

Figure (d)

Figure (a) shows a two pole machine with single equivalent conductor in each slot and the main field mmf ( $F_m$ ) acting alone. The axis of the main poles is called the direct axis (d-axis) and the inter polar axis is called quadrature axis (q-axis). It can be seen from the Figure (b) that  $AT_a$  is along the inter polar axis as shown.  $AT_a$  which is at  $90^\circ$  to the main field axis is known as cross magnetizing mmf. Figure (b) shows the armature mmf ( $F_A$ ) acting alone.

Figure (c) shows the practical condition in which a DC machine operates. Both the main flux i.e.,  $AT_f$  (Field mmf) and  $AT_a$  (armature mmf) are existing. Because of both mmf acting simultaneously, there is a shift in brush axis and crowding of flux lines at the trailing pole tip and flux lines are weakened or thinned at the leading pole tip. (The pole tip which is first met in the direction of rotation by the armature conductor is leading pole tip. (The pole tip which is first met in the direction of rotation by the armature conductor is leading pole tip and the other is trailing pole tip)

If the iron in the magnetic circuit is assumed unsaturated, the net flux/pole remains unaffected by the armature reaction though the air gap flux density distribution gets distorted. If the main pole excitation is such that the iron is in the saturated region of magnetization (practical case) the increase in flux density at one end of the poles caused by armature reaction is less than the decrease at the other end, so that there is a net reduction in the flux/pole. This is called the demagnetizing effect. Thus it can be summarized that the nature of armature reaction in a DC machine is

- (i) Cross magnetizing with its axis along the q-axis.
- (ii) It causes no change in flux/pole if the iron is unsaturated but causes reduction in flux/pole in the presence of iron saturation. This is termed as demagnetizing effect.

The resultant mmf 'F' is shown in figure (d)

The cross magnetizing effect of the armature reaction can be reduced by making the main field ampere-turns larger compared to the armature ampere-turns such that the main field mmf exerts predominant control over the air gap. This is achieved by

- (i) Introducing saturation in the teeth and pole shoe.
- (ii) By chamfering the pole shoes which increases the air gap at the pole tips. This increases the reluctance to the path of main flux but its influence on the cross-flux is much greater.
- (iii) The best and most expensive method is to compensate the armature reaction mmf by a compensating winding located in the pole-shoes and carrying a suitable current.

## Commutation

The process of reversal of current in the short circuited armature coil is called 'Commutation'. This process of reversal takes place when coil is passing through the interpolar axis (q-axis), the coil is short circuited through commutator segments. Commutation takes place simultaneously for 'P' coils in a lap-wound machine and two coil sets of  $P/2$  coils each in a wave-wound machine.

The process of commutation of coil 'B' is shown below. In figure (a) coil 'B' carries current from left to right and is about to be short circuited in figure (b) brush has moved by  $1/3$  rd of its width and the brush current supplied by the coil are as shown. In figure (c) coil 'B' carries no current as the brush is at the middle of the short circuit period and the brush current is supplied by coil C and coil A. In figure (d) the coil B which was carrying current from left to right carries current from right to left. In fig (e) spark is shown which is due to the reactance voltage. As the coil is embedded in the armature slots, which has high permeability, the coil possess appreciable amount of self-inductance. The current is changed from  $+I$  to  $-I$ . So due to self-inductance and variation in the current from  $+I$  to  $-I$ , a voltage is induced in the coil which is given by  $L \frac{dI}{dt}$ . Fig (f) shows the variation of current plotted on the time axis. Sparking can be avoided by the use of interpoles or commutating-poles.



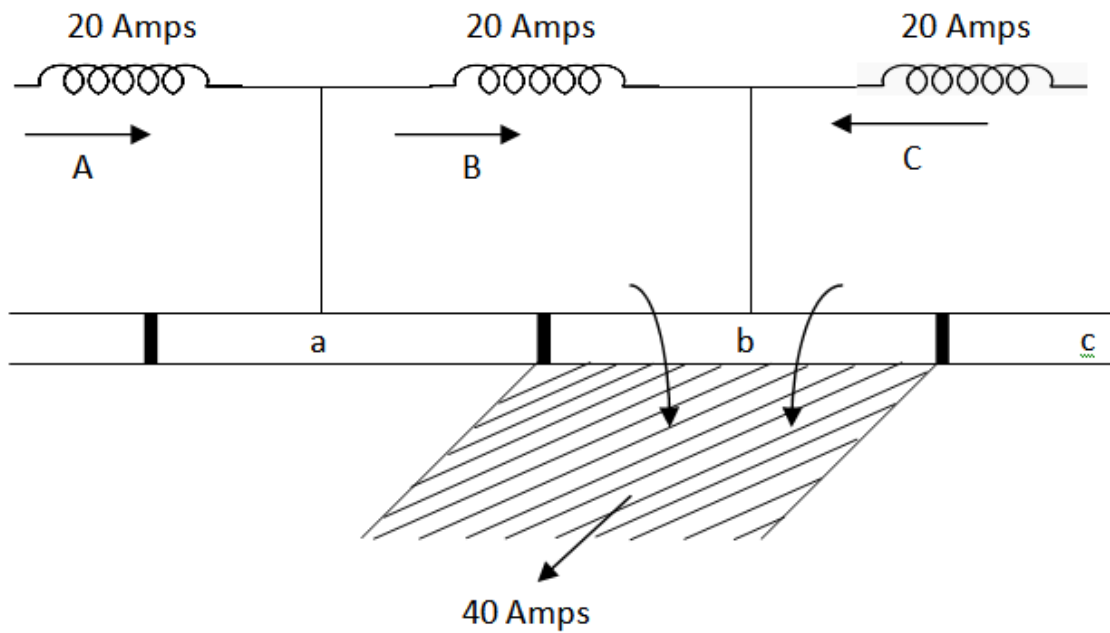

Fig (a)

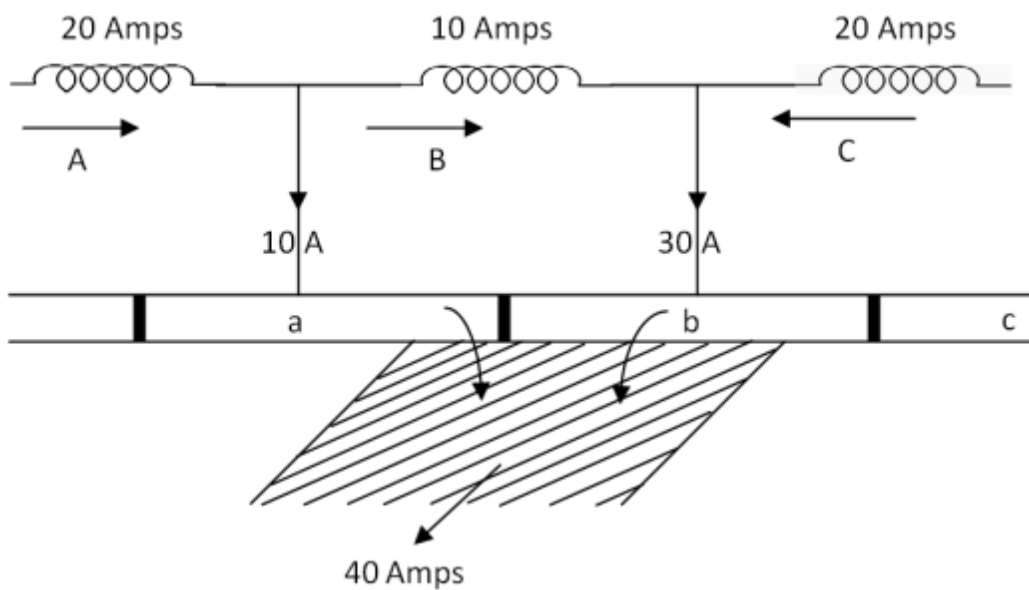
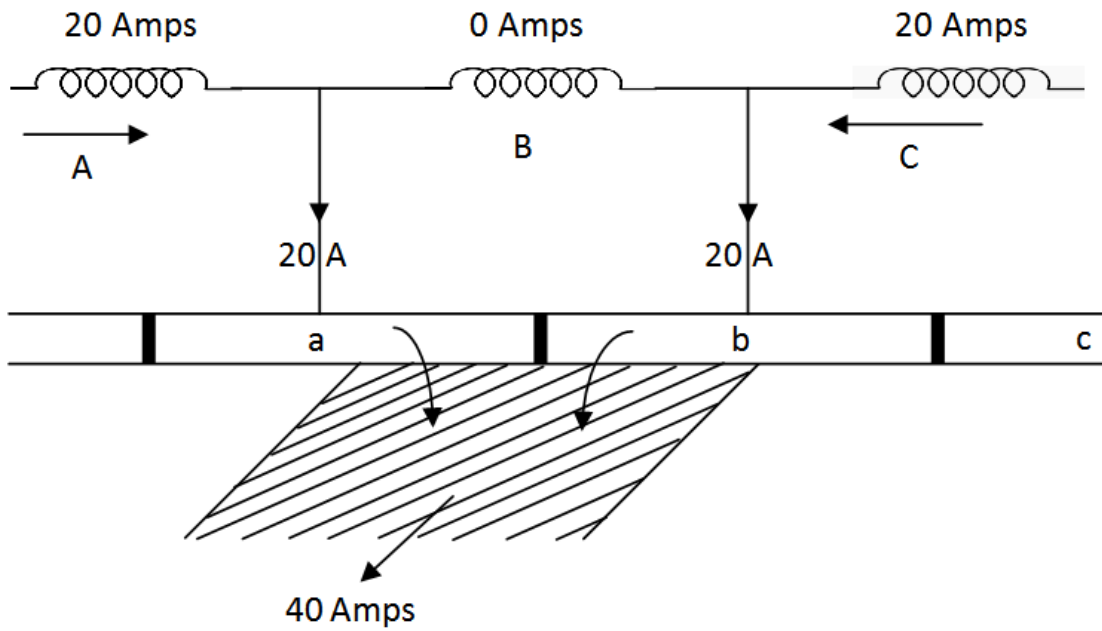

Fig (b)



Fig(c)

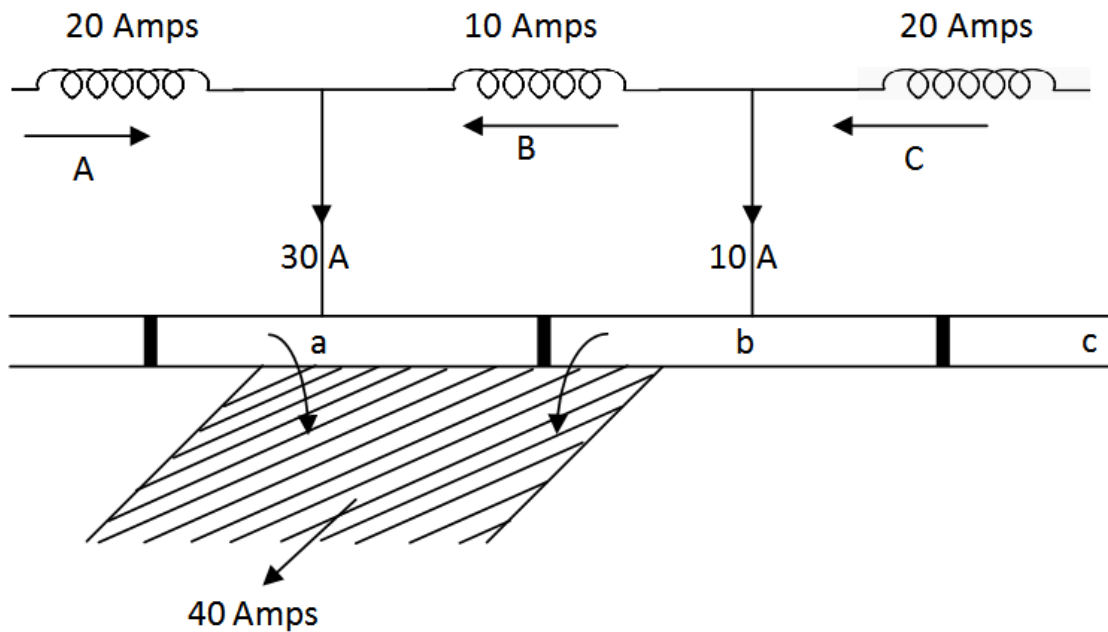

Fig (d)

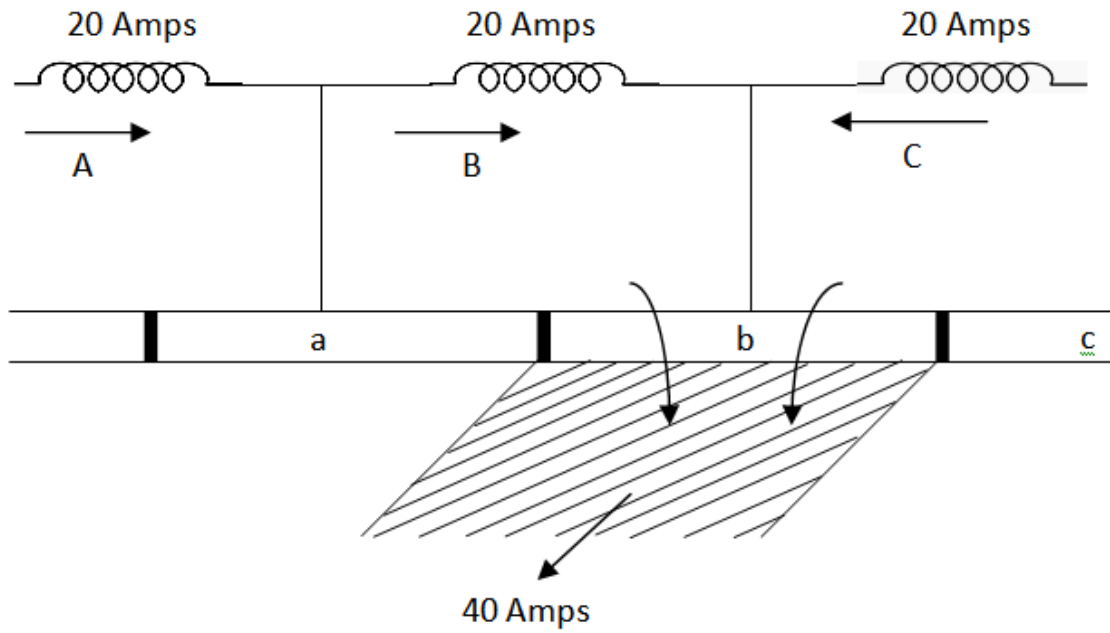

Fig (e)

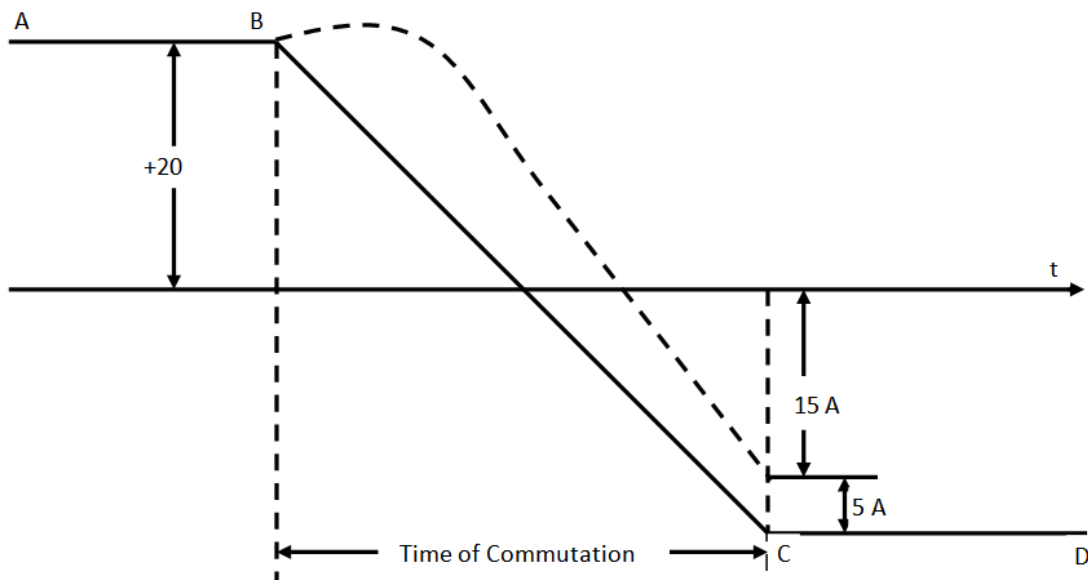
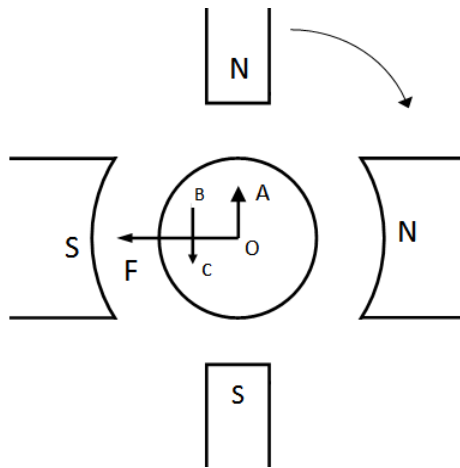

Fig (f)

**INTERPOLES OR COMPOLES**



These are small poles fixed to the yoke and placed in between the main poles as shown in figure, they are wound with few turns of heavy gauge copper wire and are connected in series with the armature so that they carry full armature current. Their polarity in case of generator is that of the main pole ahead in the direction of rotation. The function of interpoles is (i) to induce an emf which is equal and opposite to that of reactance emf thereby making commutation sparkles. (ii) Interpoles neutralize the cross magnetizing effect of armature reaction in fig. ‘OF’ represents mmf due to main poles and ‘OA’ represents the cross magnetizing mmf due to armature. ‘BC’ represents mmf due to Interpoles and is in opposite to that of ‘OA’ resulting in the cancellation of cross magnetization.

**Basic principle of D.C machine as a motor:-**For clear understanding the **principle of DC motor** we have to determine the magnitude of the force, by considering the diagram below.

We know that when an infinitely small charge  $dq$  is made to flow at a velocity ‘v’ under the influence of an electric field E, and a magnetic field B, then the Lorentz Force  $dF$  experienced by the charge is given by

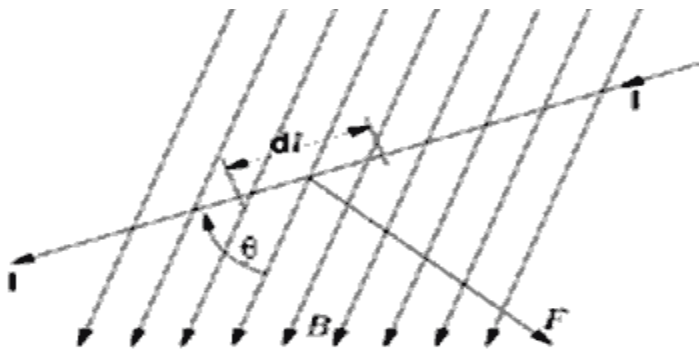

**Fig1**

$$dF=dq(E+vB)$$

For the **operation of dc motor**, considering  $E = 0$

$$dF=dq(v \times B)$$

Where  $dL$  is the length of the conductor carrying charge  $q$ .

$$dF=dq(v \times B)$$

$$F=IL \times B=ILB \sin \theta$$

$$F=BIL \sin \theta$$

From the 1<sup>st</sup> diagram we can see that the construction of a DC motor is such that the direction of current through the armature conductor at all instance is perpendicular to the field. Hence the force acts on the armature conductor in the direction perpendicular to the both uniform field and current is constant.

i.e.  $\theta=90^0$

So if we take the current in the left hand side of the armature conductor to be  $I$ , and current at right hand side of the armature conductor to be  $-I$ , because they are flowing in the opposite direction with respect to each other.

Then the force on the left hand side armature conductor,

$$F_i=BIL \sin 90^0=BIL$$

Similarly force on the right hand side conductor

$$F_T=B(-I)L \sin 90^0=-BIL$$

where,  $F$  = Force in Newtons

$B$  = Flux density in Weber/ meter<sup>2</sup>

$I$  = Current in amperes flowing through the conductor

$L$  = Length of the conductor in meters

**By Fleming's left hand rule:-**It states that “when the thumb, fore finger and middle finger are held mutually perpendicular to each other, with the fore finger in the direction of magnetic field, middle finger in the direction of the current, then the direction of thumb indicates the direction of force experienced by the conductor”.

**Types of DC Motors:** -Separately Excited DC Motor: - As the name suggests, in case of a separately excited DC motor the supply is given separately to the field and armature windings. The main distinguishing fact in these types of dc motor is that, the armature current does not flow through the field windings, the field winding is energized from a separate external source.

From the torque equation of dc motor we know  $T_g = K_a \phi I_a$  So the torque in this case can be varied by varying field flux  $\phi$ , independent of the armature current  $I_a$ .

**Self-Excited DC Motor:-**In case of self-excited dc motor, the field winding is connected either in series or in parallel or partly in series, partly in parallel to the armature winding, and on this basis its further classified as

- (1) DC Shunt Motor
- (2) DC Series Motor
- (3) DC Compound Motor

(i) Cumulative Compound Motor

- (a) Long shunt
- (b) Short shunt

(ii) Differential Compound Motor

- (a) Long shunt

(b) Short shunt

**DC Shunt Motor:** -In this type of motor, the field winding is connected in parallel with armature as shown in Figure (a). There are as many number of field coils as there are poles. When connected to supply, constant voltage appears across the field windings (as they are connected in parallel with armature). The field current is therefore constant and is independent of the load current.

Shunt field winding usually are designed to have large number of turns of fine wire. Its resistance, therefore, is high enough to limit the shunt field current to about 1 to 4 percent of the rated motor current

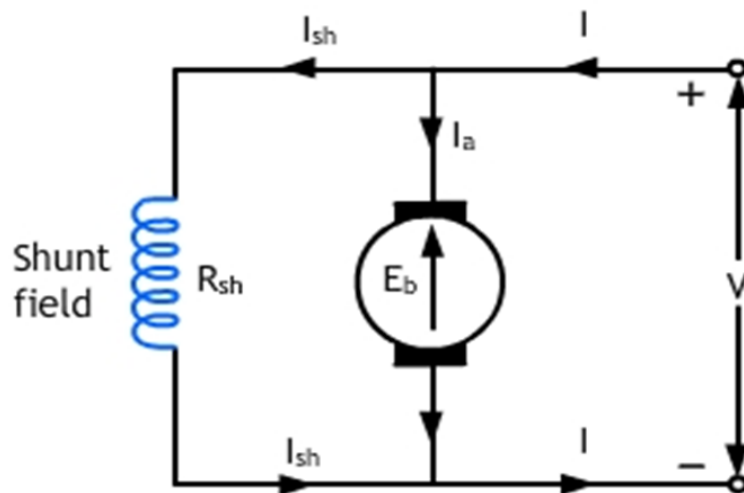

$$I_{sh} = V/R_{sh} \text{ and}$$

$$I_a = I - I_{sh}$$

where  $I$  is the line current

$$E_b = V - I_a R_a - B.C.D - A.R.D$$

where B.C.D is brush contact drop(1 V/brush), A.R.D is the armature reaction drop

**DC Series Motor:** -A series motor receives its excitation from a winding which is connected in series with the armature and carries load current. As the series field has to carry high load current, it is made of a thick wire and a few turns. As the resistance is low, the voltage drop across the series winding is small.

This motor has excellent starting and over-load torque characteristics. The disadvantages are that the motor attains dangerously high speed at no-load. Speed adjustment of the motor is somewhat difficult.

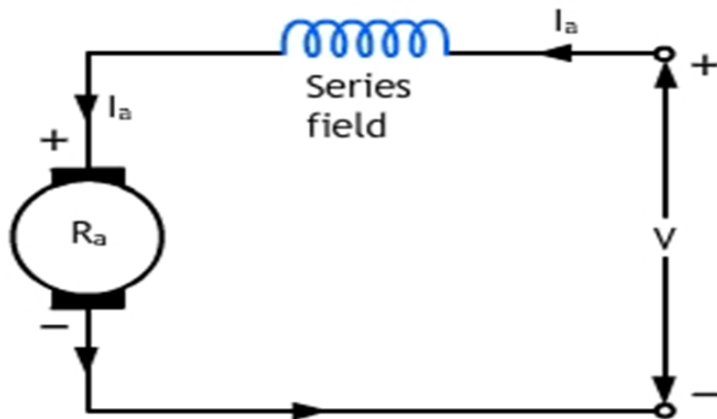

$$I_a = I = I_{se}$$

$$E_b = V - I_a (R_a + R_{se}) - B.C.D - A.R.D.$$

**DC Compound Motor:** -In compound motors excitation results from combined action of both shunt field winding and series field winding. In the short-shunt connection, which is sometimes used, the shunt field is directly connected in parallel with the armature, in which case, the series field current is the same as the line current. Excitation of a compound motor is a combination of series and shunt excitation. The motor, therefore, has mixed characteristic between that of a series motor and a shunt motor. These motors behaves somewhat better than a shunt motor from the point of view of starting and overload torque; and has definite stable no-load speed like a shunt motor. Speed of this motor is adjustable as easily as that of a shunt motor. It's speed,



however, tends to change as much as 25 percent between full-load and no-load due to the effect of series winding.

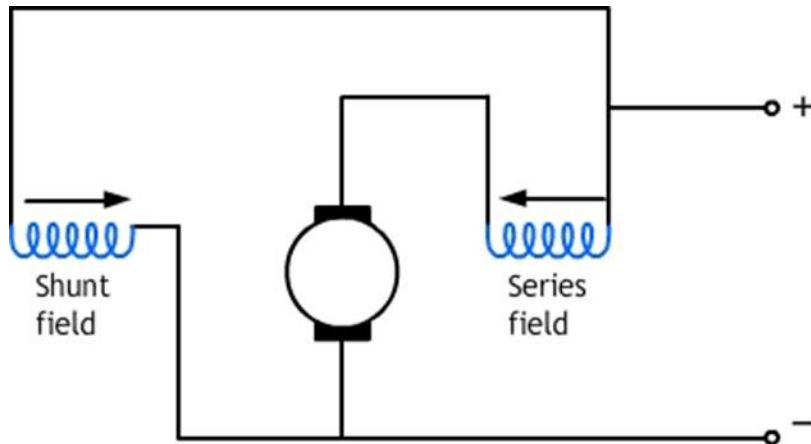

**Differential compound motor**

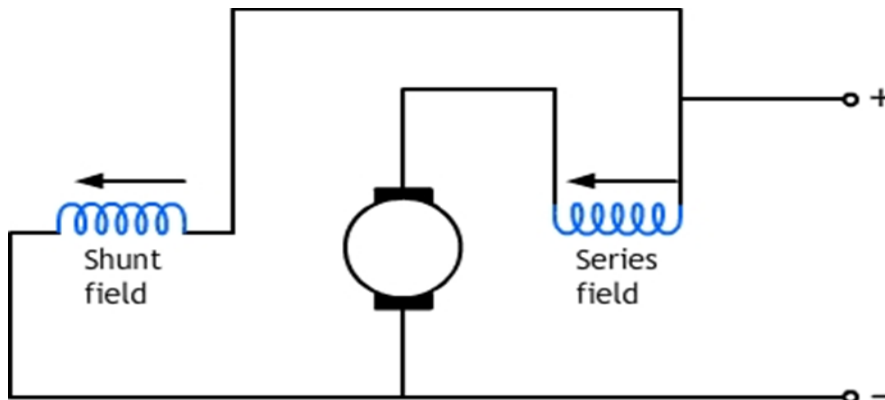

**Cumulative compound motor**

**Back EMF ( $E_b$ ):** When the voltage  $V$  is applied to the motor, current  $I_a$  will flow through the armature and  $I_{sh}$  will flow through the field of the motor which will set the flux causing EMF. The EMF developed in the armature opposes the applied voltage and hence it is called the back e.m.f ( $E_b$ ).

The applied voltage  $V$  has to drive current through the armature conductors against the opposition of the back E.M.F and hence work has to be done. It is in the form of mechanical power developed by the armature. The armature current  $I_a$  is given by eq(1)

$$I_a = \frac{V - E_b}{R_a} \text{-----(1)}$$

$$V = E_b + I_a R_a$$

$$\text{and } E_b = \frac{\phi ZN \cdot \left(\frac{P}{A}\right)}{60} \text{ volts}$$

**Torque Equation:-**

Torque is the turning moment about its axis. It is also equal to Force x Distance

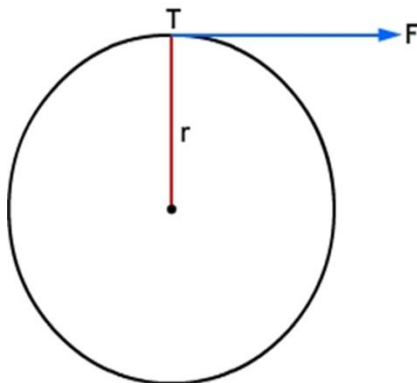

Consider the armature of the DC Motor of radius  $r$  and let  $F$  be the force acting tangential to its surface as shown in figure.

Therefore, Torque =  $T_a = F \times r$  in Newton meter ----- (1)

The work done by this force  $F$  in one revolution

$W = F \times \text{distance covered in revolution.}$

$$W = F \times 2\pi r \text{ watt second.}$$

The power developed by the armature = work done in one second.

$$= F \times r \times 2\pi N / 60 \quad \text{where } N = \text{No of revolutions / minute}$$

$$= (2\pi N / 60) \times T_a \text{ watts}$$

But power developed in the armature =  $E_b I_a$

**Therefore**  $E_b I_a = \left( \frac{2\pi N}{60} \right) \times T_a$

$$\left( \frac{\phi Z N}{60} \right) \left( \frac{P}{A} \right) \times I_a = \left( \frac{2\pi N}{60} \right) \times T_a \quad \left( \because E_b = \frac{\phi Z N P}{60 A} \right)$$

**Therefore,**  $T_a = \left( \frac{1}{2\pi} \right) \phi Z I_a \cdot \frac{P}{A} \text{ Newton meter}$

$$= 0.159 \phi Z I_a \cdot \frac{P}{A} \text{ Newton meter}$$

The actual torque or shaft torque (torque available at the shaft) or Useful torque =  $T_{sh} = T_a - T_L$

where  $T_{sh}$  = shaft torque

$T_a$  = armature torque

$T_L$  = lost torque due to iron losses and mechanical losses

$$\text{Output} = 2\pi N T_{sh} / 60$$

$$T_{sh} = \text{output} \times 60 / 2\pi N$$

If output is in Horse Power,

$$T_{sh} = \text{output in H.P} \times 735.5 / (2\pi N / 60) \text{ N-M}$$

**Characteristics of DC Shunt Motor:**

(a) **Ta/Ia characteristics (electrical characteristics):-** As assumed that flux  $\phi$  is constant in the shunt machine

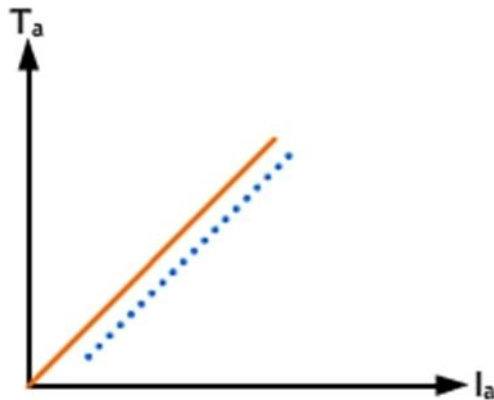

$$T_a \propto I_a$$

This implies that the characteristic is a straight line. Larger armature current is required to start a heavy load. Therefore a shunt motor should not be started on heavy load.

(b) **N/Ia characteristics:-**

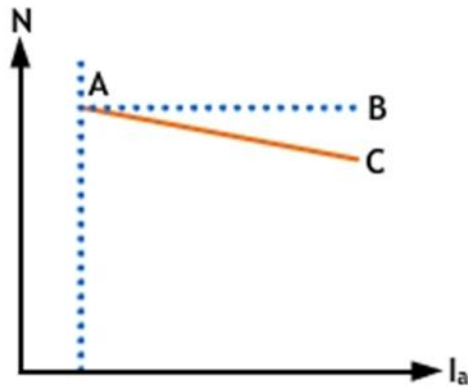

$N \propto (E_b/\phi)$ , As  $\phi$  is assumed to be constant,  $N \propto E_b$ . As  $E_b$  is also practically constant, the speed is constant.

However, to be accurate both  $E_b$  and  $\phi$  decrease with increasing load. But  $E_b$  decreases somewhat more than  $\phi$  so that there is some decrease in speed, the drop ranging from 5 to 15 % of full load, depending on certain other conditions. The actual speed curve will be somewhat dropping as shown by line AC.

The characteristic does not have a point of zero armature current, because a small current is necessary to maintain the rotation of motor at no-load.

As there is no change in the speed of shunt motor, during the transition from no load to full load, it may be connected to loads which can be suddenly disconnected without fear of excessive speeding.

**(c) N/T<sub>a</sub> characteristics or mechanical characteristics:-**

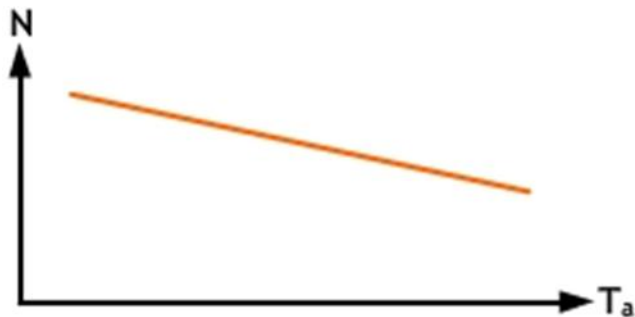

The values of  $N$  and  $T_a$  for various armature currents  $I_a$  is shown. The speed falls as the load torque increases.

The  $N/T_a$  characteristic is of great importance in determining which type of motor is best suited to drive a given load.

**Characteristics of series motor**

**(a) Torque vs. armature current characteristic**

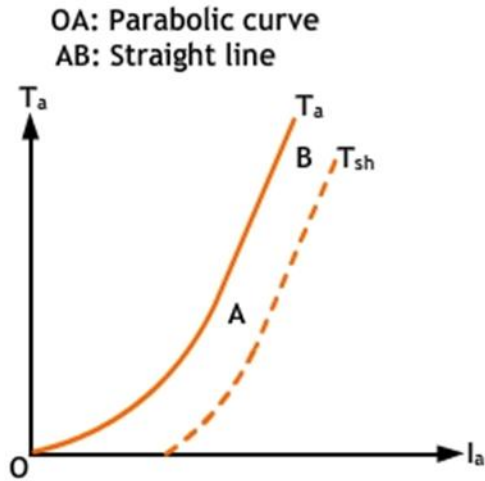

Since  $T \propto I_a^2$  in the linear zone and  $T \propto I_a$  in the saturation zone, the  $T$  vs.  $I_a$  characteristic is as shown in fig.

At light loads,  $I_a$  and hence  $\phi$  is small, but as  $I_a$  increases,  $T_a$  increases as the square of the current in a parabolic manner till the point of saturation A is reached.

After saturation  $\phi$  is practically independent of  $I_a$ , hence  $T_a \propto I_a$  and so that the characteristic becomes straight line.

**(b) Speed vs. armature current**

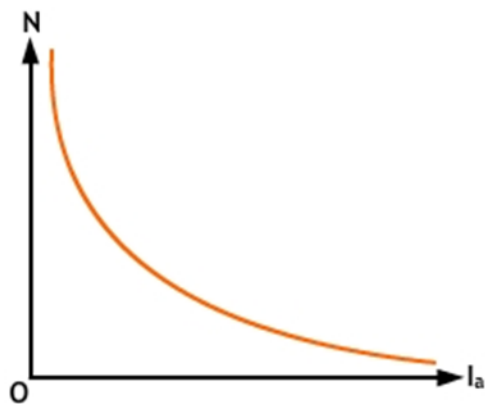

The changes in speed can be determined from the formula

$$N \propto (E_b / \phi)$$

variation of  $E_b$  for different load currents is negligible that  $E_b$  may be treated as a constant. If  $I_a$  is increased, flux  $\phi$  too increases. So speed is inversely proportional to the armature current.

When there is heavy load  $I_a$  is large. But when the load and consequently  $I_a$  decreases to a low value, the speed becomes dangerously high. Hence, a series motor should invariably be started with some mechanical load on it, to prevent excessive speed and damage due to heavy centrifugal forces produced.

**(c)Speed vs. Torque characteristic**

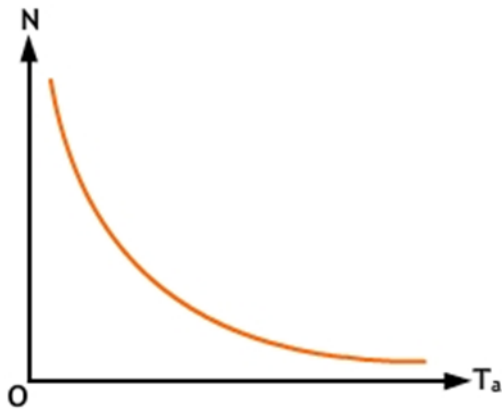

The speed vs torque characteristic of a series motor is shown. From the curve, it is apparent that the series motor develops a high torque at low speed and vice versa. This is because an increase in torque requires an increase in armature current, which is also the field current. The result is that the flux is strengthened and hence speed drops. Similarly, at low torque, the motor speed is high.

**Characteristics of DC Compound Motor:**

In the cumulative compound motor as  $I_a$  increases, flux  $\Phi_{se}$  increases but the shunt field current  $I_{sh}$  and  $\phi_{sh}$  remain constant and total flux increases.

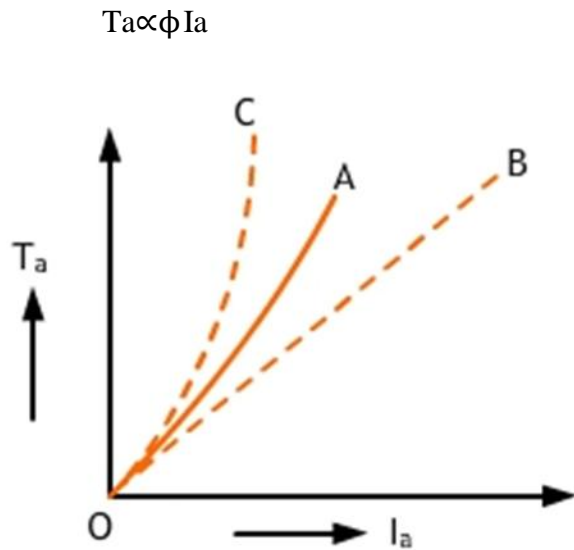

Fig(A)

As the armature current is increased, the series flux increases, thus increasing the total flux of the motor. As a result of this, the torque is increased. The increase of torque  $T_a$  with armature current is shown by a  $T_a/I_a$  characteristic curve OA. This increase of  $T_a$  with  $I_a$  is greater than what it is in the case of shunt motor (dotted curve OB) less than what it is in the case of series motor develops a high torque with sudden increase in load.

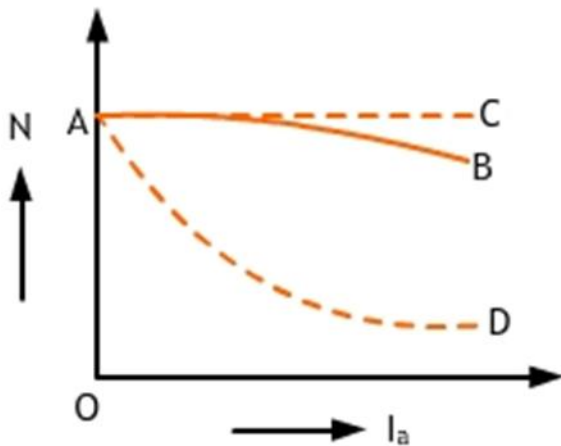

Fig (B)

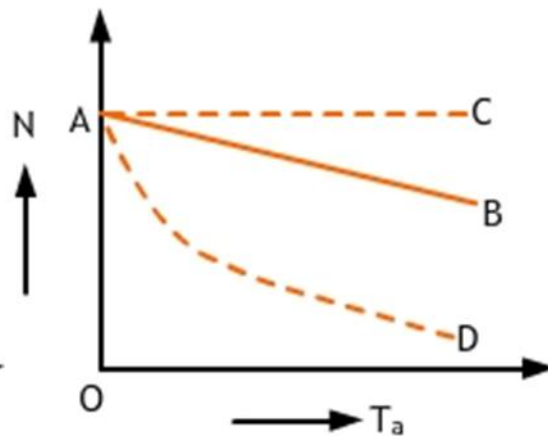

Fig (C)



We have just discussed that, with the increase of  $I_a$ , the series flux and hence total flux increases. This leads to decrease in motor speed, starting from a particular value given by the point A at no-load. The variation of  $N$  with  $I_a$  is given by the characteristic AB in fig (B). Again, the decrease in speed is greater than what it would be in the case of a shunt motor (given by the dotted curve AC), but less than what it would be in the case of a series motor.

As series excitation assists shunt excitation, the  $N/T_a$  characteristic curve AB will lie between that of a shunt motor(dotted line AC) and of a series motor(dotted line AD)

### Applications of DC Motors:

**(1)DC Shunt Motor:** When constant speed is required DC shunt motors are used.

Example: Lathes, Centrifugal pumps, fans, drilling machines. etc.

**(2)DC Series Motor:** For high starting torque we prefer DC series motor. Example: Electric traction, electric locomotive, cranes, hoists, conveyors etc.

**(3)DC Compound Motor:** When we require constant speed and high starting torque Cumulative compound motors are preferred. Example: shears, punches, coal cutting machine, elevators, conveyors, printing presses etc. Differential compound motors have no practical applications (being unstable).

### Necessity of Starter

We know armature current in a d.c motor is given by

$$I_a = (V - E_b) / R_a, \text{ at starting, } E_b = 0, \text{ therefore } I_a = V/R_a$$

At the instant of starting, rotor speed  $n = 0$ , hence starting armature current is  $(I_a)_{st} = (V/R_a)$  Since, armature resistance is quite small, starting current may be quite high (many times larger than the rated current). A large machine, characterized by large rotor inertia (J), will pick up speed rather slowly. Thus the level of high starting current may be maintained for quite some time so as to cause serious damage to the brush/commutator and to the armature winding. Also the source should be capable of supplying this burst of large current. The other loads already

connected to the same source, would experience a dip in the terminal voltage, every time a D.C motor is attempted to start with full voltage. This dip in supply voltage is caused due to sudden rise in voltage drop in the source's internal resistance. The duration for which this drop in voltage will persist once again depends on inertia (size) of the motor.

Hence, for small D.C motors extra precaution may not be necessary during starting as large starting current will very quickly die down because of fast rise in the back emf. However, for large motor, a starter is to be used during starting.

### 3-POINT STARTER

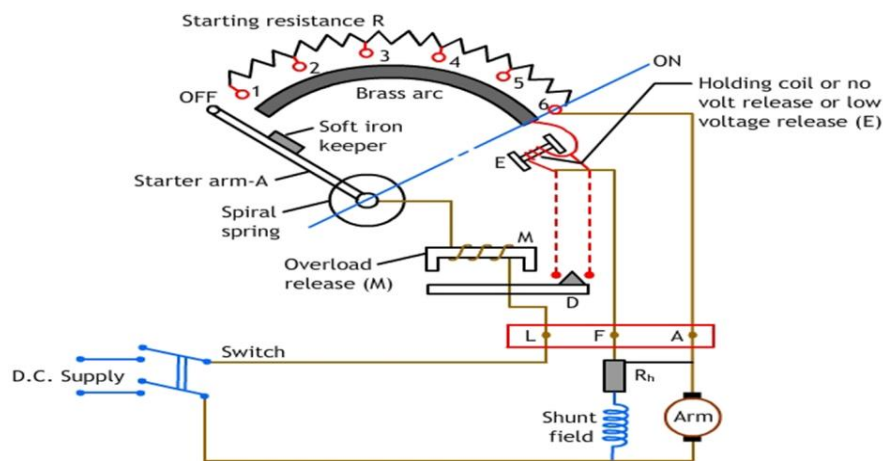

**Fig: 3 point starter**

- L, F, A are the three terminals of the starter, to which external connections are made.
- R is the starting resistance, which is divided into various studs.
- To start the motor, close the supply switch and the brass arm L is moved to the right to touch stud no.1 of R.
- It also touches the brass arc, thus current will flow through shunt field winding as well as the armature.
- The motor starts rotating, the starting arm is moved gradually and completely when the speed is above 50% of its rated speed.

- Speed can be increased by field rheostat  $R_h$  if required.
- As long as motor is running and the supply is on, the brass arm L is held in the ON position by the electromagnet E.

There are two protective devices in the starter; one is the electromagnet, (hold on coil).

- Under running condition when the power fails electromagnet E de-energizes and the spring S attached to the brass arm pulls back to OFF position.
- The electromagnet E also prevents the motor from reaching dangerously high speed, when the field circuit is opened under running condition. The second protective device is an electromagnet M which, is known as the “over load release” (Over load protection).
- When the current increases beyond the rated value, M attracts D; thereby short circuiting the electromagnet E. The electromagnet E gets de- energized and hence the arm L is pulled back to OFF position.
- This starter is normally used for starting D.C shunt motors.

## Problems

- 1) A 6 pole lap wound dc generator has 51 slots, each slot has 18 conductors. The useful flux per pole is 35 mwb. Find the generated emf in the armature, if it is driven at a speed of 750 rpm.

Given:  $P = 6$

$A = P$  (lap wound)

Number of slots = 51

Conductors/slot = 18

Total No. of conductors =  $51 * 18 = Z$

$\phi = 35\text{mwb}$ ;  $N = 750$  rpm,

emf generated

$$= \frac{\phi ZN}{60} \left( \frac{P}{A} \right) \text{ volts} = \frac{(35 \times 10^{-3}) \times (51 \times 18) \times 750 \times 6}{60 \times 6}$$

= 401.6 volts.

- 2) An 8 pole d.c. generator has 650 armature conductors. The flux per pole is 20 mWb. Find the value of emf generated when the armature is wave wound and is rotating at a speed of 1200 rpm. What must be speed at which the armature is to be driven to generate the same emf, if the armature is lap wound.

generate the same emf, if the armature is lap wound.

Given: P = 8;

A = 2 (wave wound)

No. of conductors = 650

$\phi$  = 20 mWb; N = 1200 rpm,

emf generated

$$= \frac{\phi ZNP}{60A} \text{ volts} = \frac{(20 \times 10^{-3}) \times (650) \times 1200 \times 8}{60 \times 2} = 1040 \text{ volts}$$

To find the speed of armature, when it is lap wound,

$$N = \frac{E_g \times 60A}{\phi ZP} = \frac{(1040) \times 60 \times 8}{(20 \times 10^{-3}) \times (650) \times 8} = 4800 \text{ rpm}$$

- 3) A d.c series motor is running with a speed 800 rpm while taking a current of 20 A from the supply. If the load is changed such that the current drawn by the motor is increased to 50A, calculate the speed of the motor on new load. The armature and series field winding resistances are 0.2 ohm and 0.3 ohm respectively. Assume that the flux produced is proportional to the current. Assume the supply voltage as 250 V.

For load 1,  $N_1 = 800 \text{ rpm}$ ,  $I_1 = I_{a1} = 20 \text{ A}$

For load 2,  $I_1 = I_{a2} = 50 \text{ A}$

$$E_{b1} = 240 \text{ V} \dots\dots\dots(E_{b1} = V - I_{a1} (R_a + R_{se}))$$

$$E_{b2} = 225 \text{ V} \dots\dots\dots(E_{b2} = V - I_{a2} (R_a + R_{se}))$$

$$\frac{N_2}{N_1} = \left( \frac{E_{b2}}{E_{b1}} \right) \times \left( \frac{I_{a1}}{I_{a2}} \right)$$

$$N_2 = 300 \text{ rpm.}$$

- 4) The armature current of a series motor is 60 A when on full load. If the load is adjusted so that this current decreases to 40 A, find the new torque expressed as a percentage of full load torque. The flux for a current of 40 A is 70% of that when the current is 60 A.

$$T \propto \phi I_a,$$

i) Full load torque =  $T_{fl} = \phi \times 60$

ii)  $T_{40} = 0.7 \phi \times 40$

$$T_{fl} / T_{40} = 60 \phi / (0.7 \phi \times 40)$$

$$T_{40} = 0.4667 T_{fl}$$

Torque at 40 A is 46.67% of full load torque

- 5) A 4 pole 250 V d.c. shunt motor has a back emf of 240.8 V and takes a current of 20 A. Calculate the power developed. Take the resistance of the field winding as 250 ohms.

$$P = 4$$

$$V = 250 \text{ V}$$

$$E_b = 240.8 \text{ V}$$

$$I_L = 20 \text{ A}$$

$$R_{sh} = 250 \text{ ohms}$$

$$\text{Power developed} = E_b I_a$$

$$I_a = I_L - I_{sh} \text{ and}$$

$$I_{sh} = V / R_{sh}$$

$$I_{sh} = 250 / 250 = 1 \text{ A}$$

$$I_a = 20 - 1 = 19 \text{ A.}$$

$$\text{Power developed} = 240.8 \times 19 = 4572.8 \text{ W.}$$

- 6) A 230 V dc series motor takes 12 A and runs at 800 rpm. At what speed will it run, when 10 ohm resistance is connected in series with the armature the motor taking the same current at the same supply voltage. Take  $R_a$  and  $R_{se}$  of the motor as 0.5 ohm each.

$$V = 230 \text{ V}$$

$$I_L = I_a = I_{se} = 12 \text{ A}$$

$$R_a = R_{se} = 0.5 \text{ ohms}$$

$$E_{b1} = V - I_{se}R_{se} - I_aR_a.$$

$$= 230 - 12 \times 0.5 - 12 \times 0.5 = 218.$$

When 10-ohm resistance is connected in series with the armature, then

$$E_{b2} = V - I_{se} (R_{se} + R_a + 10)$$

$$= 230 - 12(0.5 + 10 + 0.5) = 98 \text{ V}.$$

Let  $N_2$  be the corresponding speed then

$$E_{b2}/E_{b1} = (N_2/N_1) \times (f_1/f_2) \quad \text{Since } f_1 = f_2$$

$$N_2 = (E_{b2}/E_{b1}) \times N_1$$

$$N_2 = 98 \times 800/218 = 359.6 \text{ rpm}.$$

**Note:-**Figures are taken from Basic electrical science Dayananda Sagar College of Engineering and Different generators from internet.

**MODULE IV (B)**

**SYNCHRONOUS GENERATOR**

**Introduction:**

The machines generating ac emf are called as alternators. These work at specific constant speed called synchronous speed and hence in general called synchronous generators. The main difference b/w DC generators and alternators is that in alternators the field is rotating while armature is stationary and the commutator absent.

**Principle of Operation:**

- Alternator (A.C generator) operates on the basic principle of electromagnetic induction i.e., when a conductor moves across a magnetic field or vice versa, an emf is induced in the conductor (Dynamically induced emf).
- The magnetic poles are excited by D.C. supply with a source of 125 V or 250 V.
- The exciting current is obtained from small DC Generator which is mounted on the shaft of the synchronous machine.
- When the rotor is rotated by means of any prime mover the stator conductors are cut by magnetic field, hence an emf is induced in the stator conductor.
- The frequency of the induced emf is given by  $f = PN/120$  Hz where P is the number of poles and N is the speed in rpm.

**Advantages of Stationary Armature:**

1. It is simpler to insulate a stationary armature winding.
2. It is easier to brace armature winding against any deformation.
3. Only two slip rings are required for D.C supply for the rotor circuit.
4. Higher speed of the rotating field is possible.
5. It is easy to take power out from the stationary armature.

**Construction of Alternator:**

The alternator consists of two parts: Stator and Rotor. Most of the alternators has stator as armature and rotor as field.

**Stator:**

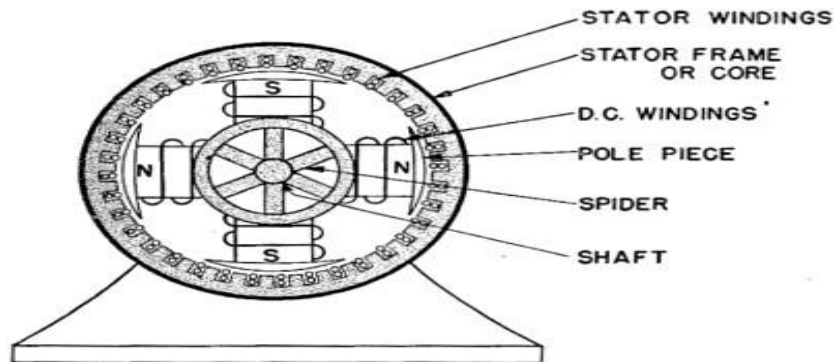

Fig: 4.2.1. Stator of alternator [Ref: [www.google.com](http://www.google.com)]

It is stationary part of an alternator and it is built up of sheet steel of thin laminations having slots on its inner periphery (shown in figure). A three phase star connected winding is placed in the slots. The neutral of the winding is grounded. Steel is chosen to reduce hysteresis loss and laminated to reduce eddy current loss.

**Rotor:** There are two types rotors namely: Salient pole rotor and. Smooth cylindrical rotor

**Salient pole rotor:**

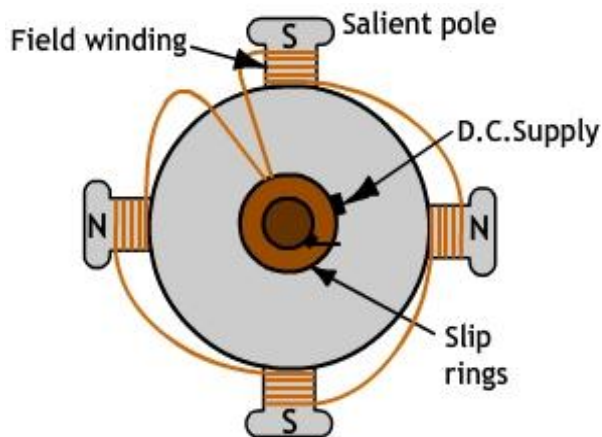

Fig:4.2.2(a) Salient pole Rotor

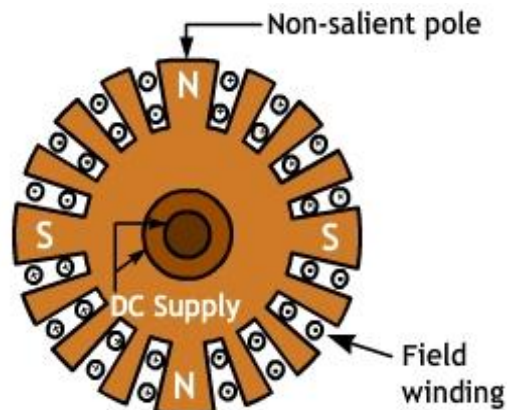

Fig:4.2.2(b) Smooth cylindrical Rotor

[Ref: DSI ppt]



**Salient pole Rotor:**

This is known as projected pole type as all the poles are projected out from the surface of the surface. Poles are made of thick steel laminations and bolted to rotor. These rotors have large diameter and small axial lengths. Mechanical strength is less, preferred for low speed alternators(125rpm-500rpm)

**Smooth cylindrical rotor:** This is known as non-salient type of rotor. The un slotted portions are the poles and surface is smooth which maintains uniform air gap b/w stator and rotor. These have small diameters and large axial lengths. Mechanically strong and can be used for high speed alternators (1500rpm-3000rpm)

**Frequency of generated EMF:**

If a conductor passes through a pair of poles, a complete cycle of emf will be induced.

Let  $f$  = frequency of generated emf,  $P$  = no of poles,  $N$  = speed in rpm.

Therefore, in one revolution,  $(P/2)$  pair of poles sweep past every armature conductor hence  $(P/2)$  emf cycles in one revolution. In one second there are  $N/60$  revolutions of rotor. Therefore, number of cycles of the induced emf /sec = number of cycles/revolution x No. of revolutions/sec.

$$(P/2) \times (N/60) = PN/120$$

i.e.,  $f = PN/120$  Hz.

**EMF Equation of Synchronous Generator:**

Let  $Z$  = number of conductors in series per phase

$P$  = number of poles

$\phi$  = Flux per pole in webers

$f$  = frequency of induced emf in Hertz.

$N$  = Speed of rotor in rpm

Average emf induced per conductor =  $d\phi / dt = P\phi / (60 / N) = P\phi N / 60$  volts. ----- (1)

Frequency  $f = NP / 120$  or  $N = 120f / P$

Average emf induced per conductor =  $(P\phi / 60) * (120f / P) = 2f\phi$  volts.

For  $Z$  conductors in series per phase we have,

Average emf induced per phase =  $2f\phi Z$  volts ----- (2)

If  $T$  = number of turns per phase, then  $Z = 2T$

Substituting  $Z$  in equation (2) we get,

Average emf induced per phase =  $4f\phi T$  volts

R.M.S value of emf induced =  $4.44f\phi T$  volts ... ( $K_f = \text{RMS Value} / \text{Average Value} = 1.11$ )

R.M.S value of actual emf induced per phase =  $4.44 * K_c * K_d * f\phi T$  volts.

**Winding Factor:**

The armature winding (conductor) of an alternator is distributed over the entire armature. Generally we use short pitched, distributed windings, due to which voltage induced in the armature will reduce. Short pitched windings are used to get better waveform and to reduce unwanted harmonics.

$$K_w = K_p \cdot K_d \approx 0.95$$

**Pitch Factor:**

**Pitch factor ( $K_p$ )** = (vector sum of emf / arithmetic sum of emf)

$$K_p = \cos(\alpha/2)$$

$K_p = 1$  for full pitched winding.

**Distribution factor ( $K_d$ )** = emf with distributed winding / emf with concentrated winding

$$K_d = \sin(m\beta/2) / (m \sin\beta/2)$$

$K_d = 1$  for concentrated winding.

where  $\alpha$  and  $\beta$  are short pitch angle, distribution angle respectively.

$m$  is no. of slots/pole/phase

$\beta = 180^\circ / \text{no. of slots per pole.}$

**Problems:**

1. The stator of an ac machine is wound for six poles, three phase. If the supply frequency is 25 Hz, what is the value of the synchronous speed?

Solution:  $N_s = 120f/P = 500 \text{ rpm}$

2. Calculate the phase emf induced in a 4 pole, 3 phase, 50 Hz, star connected alternator with 36 slots and 30 conductors per slot. The flux per pole is 0.05 Webers. Assume factor of 0.95.

**Solution:**

Total number of slots = 36, Frequency  $f = NP / 120 = 375 \times 16 / 120 = 50 \text{ Hz}$

No. of slots per phase =  $36 / 3 = 12$

No. of conductors per slot = 30

$\therefore$  No. of conductors per phase =  $12 \times 30 = 360$

$\therefore$  No. of turns per phase =  $T = 360 / 2 = 180$

Assuming full pitch winding, pitch factor  $K_c = 1$

$\therefore$  Phase emf =  $E_{ph} = 4K_f K_c K_d f \phi T$  volts

$$E_{ph} = 4 \times 1.11 \times 1 \times 0.95 \times 50 \times 0.05 \times 180 = 1898 \text{ V}$$

3. A 3-phase, 16 pole alternator has a star connected winding having 144 slots and 10 conductors per slot. The flux per pole is 0.03 Webers and speed is 375 rpm. Find the frequency and phase and line voltage. Winding Factor  $K_d = 0.96$ , Pitch factor  $K_c = 1$ .

**Solution:**

Flux per pole,  $\phi = 0.03 \text{ Webers}$

Frequency  $f = NP / 120 = 375 \times 16 / 120 = 50 \text{ Hz}$

No. of slots per phase =  $144 / 3 = 48$

No. of conductors per slot = 10

$\therefore$  No. of conductors per phase =  $48 \times 10 = 480$

$\therefore$  Turns per phase  $T = \text{conductors per phase} / 2 = 480 / 2 = 240$

Form factor =  $K_f = 1.11$

$\therefore$  E.M.F generated per phase =  $E_{ph} = 4K_f K_c K_d f \phi T$  volts

$$= 4 \times 1.11 \times 1 \times 0.96 \times 50 \times 0.03 \times 240$$

$$= 1534 \text{ volts.}$$

$$\therefore \text{Line emf} = \sqrt{3} \times 1534 = \mathbf{2657 \text{ volts.}}$$

4.A 3-phase star connected alternator with 12 poles generates 1100 volts on open circuit at a speed of 500 rpm. Assuming 180 turns per phase, a distribution factor of 0.96 and full pitched coils, find the useful flux per pole.

**Solution:**

Given line emf = 1100 volts

$$\therefore \text{E.M.F per phase, } E_{ph} = 1100 / \sqrt{3} = 635 \text{ volts}$$

$$f = NP / 120 = 500 \times 12 / 120 = 50 \text{ Hz}$$

$$E_{ph} = 4K_f K_c K_d f \phi T \text{ volts} \quad \text{----- (1)}$$

$$K_f = 1.11$$

For full-pitched winding,

$$\text{Pitch Factor} = K_c = 1$$

$$\text{Distribution factor} = K_d = 0.96$$

$$T = \text{No. of turns per phase} = 180$$

$\phi$  = Flux per pole (in Webers)

Substituting in expression (1) above,

$$E_{ph} = 4K_f K_c K_d f \phi T \text{ volts}$$

$$635 = 4 \times 1.11 \times 1 \times 0.96 \times 50 \times \phi \times 180$$

$$\therefore \text{Flux per pole} = \phi = 635 / 4.44 \times 0.96 \times 50 \times 180$$

$$\therefore \text{Flux per pole} = \phi = \mathbf{0.0165 \text{ Webers}}$$

MODULE-V(A)

**TRANSFORMERS**

Transformer is a static electrical device . It transfers electrical power from one circuit to other circuit , which are magnetically coupled and with no change in frequency and power. Basically transformers are employed to increase or to decrease the A.C. voltage in a Power Transmission System .

The Transformer used to increase the A.C. voltage is known as Step – Up Transformer , Transformer used to decrease the A.C. voltage is known as Step – Down Transformer and if the transformer voltage is not changed it is known One – to – One Transformer .

**PRINCIPLE OF OPERATION**

Transformer operates on the principal of mutual induction between two coils. The horizontal portion of steel core i.e, the top and bottom bars are called as Yoke. The vertical portion of the steel core is known as Limbs.

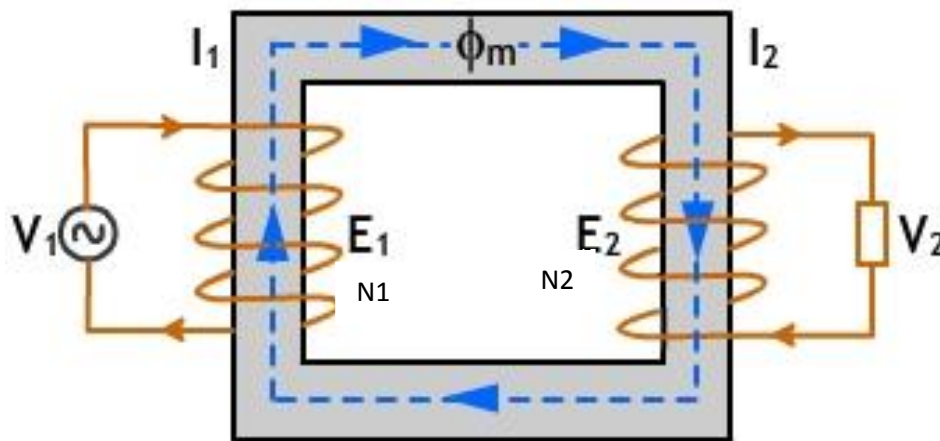

*Fig:5.1.1: Transformer [Referred from DSI ppt]*

The two coils of primary and secondary are termed as  $N_1$  and  $N_2$  as shown in the above figure , these coils are wound on the two limbs of the Transformer . They are magnetically coupled via magnetic flux in the core . The coil  $N_1$  connected to the Supply and the coil  $N_2$  connected to the load. The principles involved in the operation of transformer are , An electric current produces a magnetic field i.e., electro magnetism and changing magnetic field with in the coil induces an

EMF in the coil i.e. electromagnetic induction . Due to A.C. in the primary coil , it creates a changing magnetic field ,in turn this magnetic field induces a voltage in the secondary circuit . Thus , the electrical energy is transferred from one circuit to other circuit .

### SYMBOLIC REPRESENTATION OF TRANSFORMER

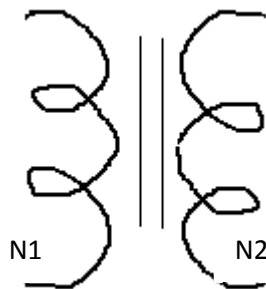

Fig 5.1.2(a): Laminated core

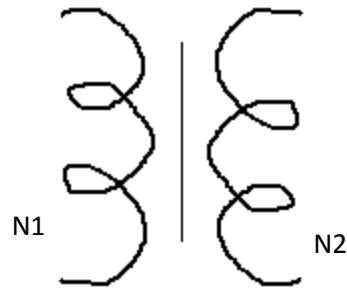

Fig 5.1.2(b): Non-laminated core.

Figure 5.1.2(a) & 5.1.2 (b) shows the transformer symbol ,the line in between the coils indicates the lamination of the core. By designing number of turns of  $N_1$  and  $N_2$  the electrical power at low or high voltage can be obtained .If the turns of the coil  $N_1$  is greater than the turns of the coil  $N_2$  then it is Step down transformer, if the turns of the coil  $N_1$  is less than the turns of the coil  $N_2$  then it is Step up transformer and if the turns of the coils  $N_1$  and  $N_2$  are equal then it is one to one transformer .

### CONSTRUCTION

In a single phase transformer shown in the figure above mentioned consists of mainly two parts , they are (a) Windings,(b) Core

The winding wound on the limbs of the transformer are insulated from each other and also from the limbs of the core . The windings are made of copper in order to posses low resistance . The windings connected to supply are termed as primary windings (with  $N_1$  number of turns) and the windings connected to load are termed as secondary windings (with  $N_2$  number of turns) .

The core is made up of silicon steel laminations to reduce eddy current losses with high relative permeability and low hysteresis co-efficient . Transformers of small size are made up of single piece of lamination and that of large size transformers are made of two or more sections of laminations like E,L,I or T .The joints of such sectioned laminations are staggered while forming the core in order to minimize the reluctance of the joints.

### WORKING PRINCIPLE

Transformer works on the principle of mutual inductance . when a primary coil is connected to an A.C. voltage  $V_1$  an alternating current ( $I_1$ ) flows through the coil and induces an A.C. flux ( $\phi$ ) in the core of the transformer . Due to magnetic coupling , the flux induced by primary coil links the secondary coil of the transformer . By the principle of electromagnetism a statically induced EMF  $e_1$  and  $e_2$  are induced in the primary and secondary windings respectively . From Faraday's Laws  $e_1$  and  $e_2$  are ,

$$E_1 = -N_1 \frac{d\phi}{dt} \quad \& \quad e_2 = -N_2 \frac{d\phi}{dt}$$

$$e_2/e_1 = N_2/N_1 = E_2/E_1 = K$$

where  $K$  = Transformation ratio of Transformer

When the secondary windings are connected to load due to  $E_2$  an A.C. ( $I_2$ ) flows through the winding and a voltage drop of  $V_2$  is obtained across the load terminal hence the voltage is termed terminal voltage. The power transferred from one circuit to another circuit is same for a transformer , hence

$$E_1 I_1 = E_2 I_2$$

$$E_2 / E_1 = I_1 / I_2 = N_2 / N_1 = K$$

( Note : The direction of  $E_1$  and  $E_2$  opposes the primary voltage  $V_1$  )

### TYPES OF TRANSFORMERS

Based on the type of winding transformers are classified as ,

- (a) Core Type Transformer
- (b) Shell Type Transformer

Core Type Transformer :

In this type of transformer the primary windings and the secondary windings are wound on the two limbs of the core and while making the symbolic representation the two windings are shown to be wound on the two different limbs of the core but in actual practice apart of primary winding and apart of secondary winding are wound on both the limbs of the core as shown in the figure below in order to reduce the leakage flux .

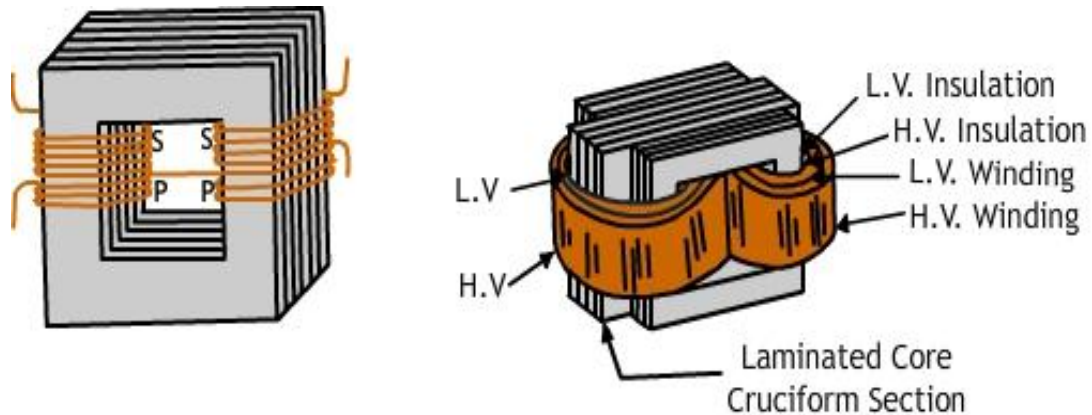

Fig: 5.1.3(a). Core type transformer [Referred from DSI ppt]

Transformer of small size is made of rectangular core and that of large sized transformers cruciform core is employed. The oval or cylindrical shaped coils are wound in helical layers with insulation from each other. The core is laminated to reduce eddy current loss. Core type transformers are employed for low and medium voltage transmission system.

Shell Type Transformer :

In this type of transformer the core has three limbs, the primary windings and the secondary windings are wound on the same middle limb of the core as shown in the figure below. Here the core surrounds the portion of the both high voltage (HV) and low voltage (LV) windings on the central limb. The windings are insulated from each other and the core. The rectangular core is used with lamination to reduce eddy current losses.

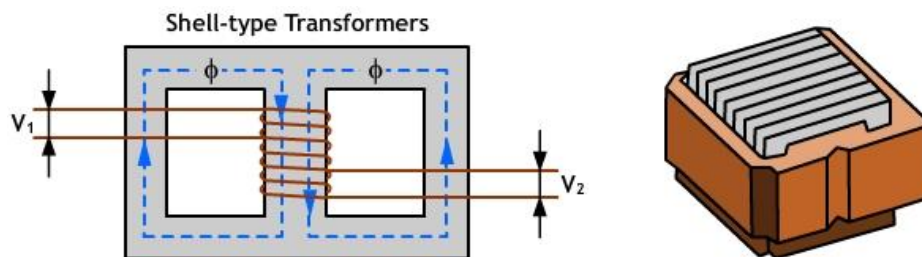

Fig 5.1.3(b) Shell type transformer [Referred from DSI ppt]

Unlike core type, in shell type transformer the total flux from primary side to secondary side divides half the times and returns through the outer limbs.



The selection made between core type and shell type is based on voltage rating , KVA rating , insulation stress , heat distribution and so on . As there is absence of space in shell type for insulation it is preferred for economical low voltage construction but in core type the availability of space is more for insulation hence preferred for high voltage application.

**EMF EQUATION OF TRANSFORMER**

Considering single phase core type transformer , by applying A.C. voltage to the primary winding with RMS value , A.C. flows through the winding ,inducing alternating flux in both primary and secondary windings . By Faraday’s Laws , an EMFs e1 and e2 are induced in the primary and secondary windings

$$V_1 = V_m \sin (\omega t)$$

$$e_1 = -N_1 d\phi / dt \text{ ----- (1)}$$

As the applied voltage is A.C. , the flux produced is also alternating in nature hence the equation for flux is given by ,

$$\Phi = \Phi_m \sin (\omega t) \text{ -----(2)}$$

Substituting equation 2 in 1 ,  $e_1 = -N_1 d(\Phi_m \sin(\omega t)) / dt$

$$= -N_1 \Phi_m \cos(\omega t)$$

$$= 2\pi f N_1 \Phi_m \sin(\omega t - 90^\circ)$$

(Note :  $\sin(90^\circ - \Theta) = \cos \Theta$  ,  $\sin(\Theta - 90^\circ) = -\cos \Theta$  , from the equation it is evident that the induced EMF lags the flux by 90°)

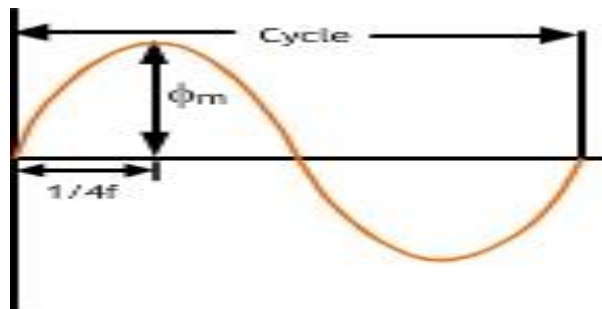

Fig 5.1.4 Sinusoidal waveform [Referred from DSI ppt]

The maximum value of the magnitude of the EMF in the primary coil is given by ,

$$E_{m1} = 2\pi f \Phi_m N_1$$

The Effective Value (RMS value ) of the EMF induced in the primary winding is given by ,

$$E_1 = E_{m1} / \sqrt{2} = 2\pi f \Phi_m N_1 / \sqrt{2} = 4.44f \Phi_m N_1$$

$$\underline{E_1 = 4.44f \Phi_m N_1}$$

The above is the equation for the effective value of the EMF of the primary winding, similarly the effective value of the EMF of the secondary winding is ,

$$\underline{E_2 = 4.44f \Phi_m N_2}$$

The EMF induced in each coils of both primary and secondary windings is of Same value .

### **CHARACERISTICS OF IDEAL TRANSFORMER**

The ideal transformer should posses the following properties ,

1. Ideal transformer has no losses .
2. Ideal transformer coils have resistance is zero .
3. The flux produced by primary completely links with the secondary windings without any leakage of flux.
4. Transformation ratio ,  $K = 1$  always .
5. The applied voltage  $V_1$  is equal to the EMF induced in the primary coil i.e.  $V_1 = E_1$  and similarly on secondary side  $V_2 = E_2$  .

### **CHARACERISTICS OF PRACTICAL TRANSFORMER**

The ideal transformer should posses the fowling properties ,

1. Practical transformer has losses .

2. Practical transformer coils have resistance value .
3. The flux produced by primary does not completely link with the secondary windings . It has leakage of flux.
4. Transformation ratio , K is always less than one .
5. The applied voltage  $V_1$  is not equal to the EMF induced in the primary coil and similarly on secondary side due to presence of losses

### EQUIVALENT RESISTANCE

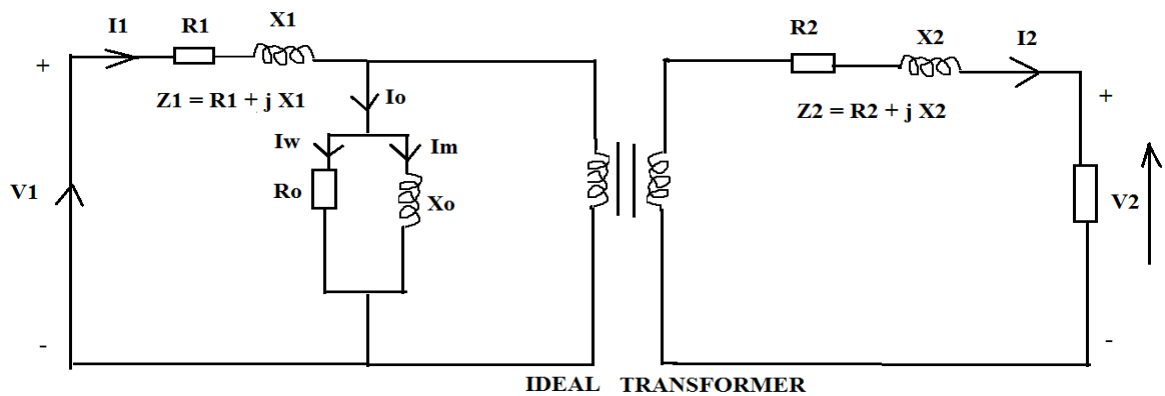

Fig: 5.1.5 Equivalent circuit of transformer

Transferring of impedances from primary and secondary side to vice versa can be done as shown in the above figure , we can even exclude ideal transformer and get the simplified circuits and equations as ,

$$\begin{aligned}
 R_{01} &= R_1 + R_2 / k^2 & X_{01} &= X_1 + X_2 / k^2 \\
 R_{02} &= R_2 + R_1 * k^2 & X_{02} &= X_2 + X_1 * k^2 \\
 Z_{01} &= Z_1 + Z_2 / k^2 & Z_{02} &= Z_2 + Z_1 * k^2
 \end{aligned}$$

### LOSSES IN A TRANSFORMER

Transformer is a static device hence it does not contain any moving parts , it has no frictional losses but has windage losses and core losses . The types of losses that occur in the transformer are , (1) Core losses, (2) Copper losses

Core losses [ $W_i$  or  $P_i$ ]: It occurs in the iron core of the transformer it is also called as Iron Losses it occurs due to presence of A.C. and frequency in the core . It is also known as Constant Loss

due the fact that the supply voltage and frequency are kept constant . It is of two types (a) Eddy current losses & (b) Hysteresis losses

Eddy current losses [ $W_e$  or  $P_e$ ]: It occurs in the transformer due to the the flow of A.C. Eddy Current in the laminated core of the transformer . It heats up the core and causes power losses in the core . It is given by Steinmetz empirical formula ,

$$\underline{W_e \text{ or } P_e = \beta * B_m^2 * f^2 * t^2 * v} \quad \text{Watts}$$

To minimize eddy current losses the core of transformer is made of thin insulated laminations from vanish or an oxide layer with high permeability magnetic material .

Hysteresis losses [ $W_h$  or  $P_h$ ] : It occurs in the core due to the fact that the it under goes number of cycles of magnetization . The Hysteresis losses of the transformer is given by ,

$$\underline{W_h \text{ or } P_h = \eta * B_m^{1.6} * f * v} \quad \text{Watts}$$

To minimize the hysteresis losses of transformer a proper magnetic material must be used for core material of the transformer .

Copper Losses [ $W_{cu}$  or  $P_{cu}$  ]: Copper losses in the transformer is due to the copper windings wound on the limbs of the transformer core . It occurs in the both primary ( $R_1$ ) and secondary ( $R_2$ ) turn resistances. It is known as variable losses as the secondary current  $I_2$  varies as per the load on transformer.

$W_{cu}$  or  $P_{cu}$  = copper losses in primary coil + copper losses in secondary coil

$$\underline{W_{cu} \text{ or } P_{cu} = I_1^2 * R_1 + I_2^2 * R_2} \quad \text{Watts}$$

In terms of equivalent resistance ,  $W_{cu} = I_1^2 * [R_1 + R'] = I_2^2 * [R_2 + R']$   
 $= I_1^2 * [R_{01}] = I_2^2 * [R_{02}]$

Where ,  $R_{01} = R_1 + R_2 / k^2$   
 $R_{02} = R_2 + R_1 * k^2$

Copper losses are minimized by designing coils with low resistance value .

Total Losses of the transformer = Iron losses + Copper losses

$$\text{Losses} = W_i + W_{cu} \quad \text{Watts}$$

### EFFICIENCY OF THE TRANSFORMER

Because of the losses in the transformer the output power [Pout] is not equal to the power input [Pin] of the transformer . Hence ,

$$\text{Power Output} = \text{Power Input} - \text{Power Losses}$$

$$\text{Power Input} = \text{Power Output} + \text{Power Losses} = P_{out} + P_i + P_{cu}$$

Efficiency of the transformer is give by ,

$$\eta = \text{Power output} / \text{Power input} = P_{out} / P_{in}$$

$$\eta = V_2 I_2 \cos \Phi_2 / V_2 I_2 \cos \Phi_2 + P_i + R_{02} I_2^2$$

where ,  $V_2 I_2 = \text{VA rating of transformer}$

$$\eta = ( \text{VA rating} ) * \cos \Phi / ( \text{VA rating} ) * \cos \Phi + P_i + [P_{cu}]_{F.L.}$$

$$\% \eta = \frac{( \text{VA rating} ) * \cos \Phi * 100}{( \text{VA rating} ) * \cos \Phi + P_i + [P_{cu}]_{F.L.}}$$

The above equation given the formula for FULL LOAD efficiency of the transformer . But on the transformer will not be a full load condition every time , so the equation for fractional loads on the transformer id given below . Accordingly the copper losses also will vary as the current  $I_2$  varies .

Let n or x = fraction load on the transformer

If the load is 50% of Full load then  $n = \text{Half load} / \text{Full load} = 50 / 100 = 0.5$

When the load varies on the transformer the load current or the secondary current  $I_2$  varies as per the fraction of the load ,  $I_2 \propto \text{Fraction Load}$

Therefore , new  $I_2 = n(I_2)_{F.L.}$  and hence , new  $P_{cu} = R_{02} (n I_2)^2$

$$\text{New } P_{cu} = n^2 [P_{cu}]_{F.L.}$$

Therefore , efficiency of the transformer for fractional load is given by ,

$$\% \eta = \frac{n * ( \text{VA rating} ) * \cos \Phi * 100}{n * ( \text{VA rating} ) * \cos \Phi + P_i + n^2 [P_{cu}]_{F.L.}}$$

Where , n or x = fractional load on the transformer

**CONDITION FOR MAXIMUM EFFICIENCY:**

(Referred from DSI ppt)

$$\text{Output power} = V_2 I_2 \cos \phi$$

If  $R_{02}$  = total resistance referred to secondary of the transformer, then

$$\text{Total copper loss at any load} = X^2 I_2^2 R_{02}$$

$$\text{Iron loss} = W_i \text{ (constant loss)}$$

$$\text{Total losses} = W_i + X^2 I_2^2 R_{02}$$

$$\eta = \frac{V_2 I_2 \cos \phi}{V_2 I_2 \cos \phi + X^2 I_2^2 R_{02} + W_i}$$

In the above equation, the load current  $I_2$  is the variable quantity. Hence, efficiency is differentiated w.r.t.  $I_2$  and equated to zero.

$$\frac{d\eta}{dI_2} = \frac{d}{dI_2} \left[ \frac{V_2 I_2 \cos \phi}{V_2 I_2 \cos \phi + W_i + X^2 I_2^2 R_{02}} \right] = 0$$

$$W_i = X^2 I_2^2 R_{02} \text{ or Iron loss} = \text{copper loss}$$

Hence efficiency of transformer is maximum when **Iron loss = copper loss**.

**OUTPUT KVA CORRESPONDING TO MAXIMUM EFFICIENCY:**

(Referred from DSI ppt)

At maximum efficiency

$$W_i = (X)^2 W_{cu}$$

$$X = \sqrt{(\text{Iron loss} / \text{full load copper loss})}$$

$$\therefore \text{Output kVA at maximum efficiency} = \text{full load kVA} \sqrt{(W_i / W_{cu})}$$

**PROBLEMS:**

(Referred from DSI ppt)

1. A 40 kVA transformer has a core loss of 450 watt, and full load copper loss of 850 watt. If the power factor of the load is 0.8, calculate (i) the full load efficiency (ii) maximum efficiency.

Solution:  $\eta$  = efficiency at 0.8 power factor and at full load.

$$\text{output} = 40 \times 0.8 \times 10^3 \text{ W}$$

$$\text{input} = 40 \times 0.8 \times 10^3 + (0.45 + 0.85) \times 10^3 \text{ W}$$

$$\eta = \text{Output/input}$$

$$= \mathbf{96.1 \%}$$

(ii) Let x be the x times full load

$$\text{Total losses} = (0.45 + 0.85 x^2) \text{ kW}$$

Iron loss = Full load copper loss (at maximum efficiency)

$$0.45 = 0.85 x^2$$

$$\therefore x = 0.7276$$

$$\text{Output at maximum efficiency} = \eta = 0.7276 \times 40 \times 0.8 = 23.28 \text{ kW}$$

$$\text{Input} = 24.18 \text{ kW}$$

$$\text{Maximum efficiency} = \frac{23.28}{24.18} \times 100 = \mathbf{96.3\%}$$

2.A 25 kVA, single-phase transformer has 500 turns on the primary and 40 turns on the secondary winding. The primary is connected to 3000 V, 50 Hz supply. Calculate (i) Primary and Secondary currents on full-load (ii) The secondary emf (iii) The maximum flux in the core.

Solution:

Given rating = 25 kVA

Primary applied voltage  $V_1 = 3000$  Volts

Number of primary turns,  $N_1 = 500$

Number of secondary turns,  $N_2 = 40$

i) Full load primary current  $I_1 = \text{kVA rating} \times 1000 / \text{Rated primary voltage, } V_1$

$$I_1 = 25 \times 1000 / 3000 = 8.33 \text{ A}$$

Turns ratio,  $K = N_2 / N_1 = 40 / 500 = 0.08$

We have,  $I_1 / I_2 = N_2 / N_1$

$$\text{Full load secondary current, } I_2 = 8.33 \{1/0.08\} = \mathbf{104.125 \text{ A}}$$

2.A 40 kVA single phase transformer has 500 turns on the primary and 100 turns on the secondary windings. The primary is connected to 3000 V, 50 Hz a.c. supply. Determine i) secondary voltage on open circuit (ii) Current flowing through the two windings on full load. (iii) Maximum value of flux.

Solution:

i) We know that

$$(V_2 / V_1) = (N_2 / N_1)$$

$$(V_2/3000) = (100/500)$$

$$V_2 = \mathbf{600 \text{ V}}$$

ii)  $V_2 I_2 = 40,000 \text{ V}$

$$\therefore I_2 = \mathbf{66.7 \text{ A}}$$

iii)  $E_1 = V_1 = 4.44 f N_1 \phi_m$

$$3000 = 4.44 \times 50 \times 500 \times \phi_m$$

$$\phi_m = \mathbf{0.027 \text{ Wb}}$$



MODULE V(B)

**THREE PHASE INDUCTION MOTOR**

**Introduction:**

A three phase induction motor is a three phase ac motor. These motors are widely used for many industrial applications. The advantages of induction motor are:

- (1) Construction is simple, rugged, unbreakable.
- (2) Low cost and highly reliable.
- (3) It has high efficiency.
- (4) It works with good power factor at rated load.
- (5) Less maintenance
- (6) Small IM are self starting and large motors starting arrangement is simple.

**Disadvantages:**

- 1. It's a constant speed motor, hence speed cannot be varied easily.
- 2. Its starting torque is less, compared to dc shunt motor.

**Construction:** A  $3\Phi$  IM has mainly two parts. Stator and Rotor.

**Stator:**

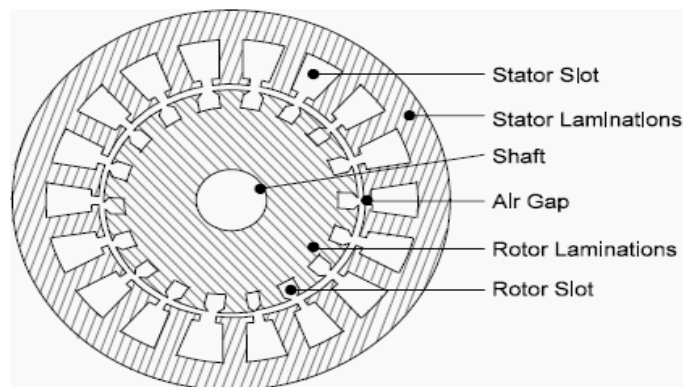

Fig. 5.2.1 Stator of three phase IM [Ref:DSI ppt]

1. The stator is enclosed in steel frame which has hollow cylindrical core made up of thin laminations of silicon steel to reduce eddy current loss and hysteresis loss.
2. The stator conductors are placed in the slots which are insulated from one another and from the slots.
3. Conductors are connected as a balanced three phase star or delta winding.
4. Windings are wound for a definite number of poles and speed.

$$N_s = 120f/P$$

$N_s$  = Synchronous speed

$f$  = frequency

$P$  = number of poles.

5. When 3 $\Phi$  supply is applied to stator winding a magnetic field of constant magnitude rotating at synchronous speed is produced.
6. Rotating magnetic field is responsible for producing torque in the rotor.

**Rotor:** It is the rotating part of IM, which is mounted on the shaft to which the mechanical load is connected. There are two types are rotor: Squirrel cage rotor and Phase wound rotor.

**Squirrel cage rotor:**

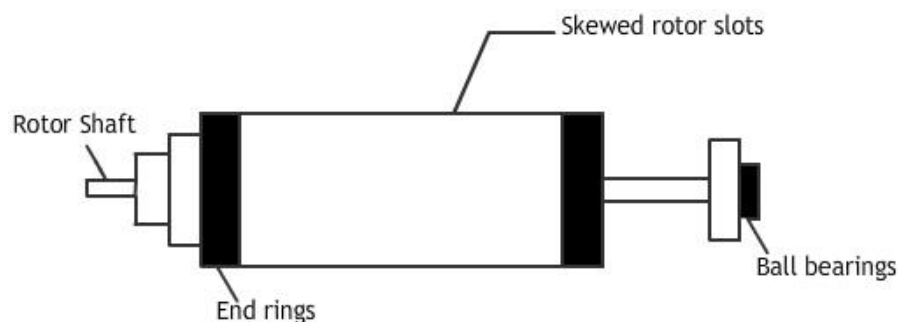

*Fig 5.2.2(a): Squirrel cage induction motor [Ref: DSI ppt]*

Almost 90% of IM are squirrel cage type, as their construction is simple and rugged. Its consists of cylindrical laminated core with slots for carrying rotor windings. The rotor windings are heavy bars of copper or aluminum. Each slot has one bar of copper placed in it. All the bars are

welded at both the ends of the end rings, thereby short circuiting both ends of the rotor. Slots are skewed to reduce the noise due to magnetic hum and to make the rotor run quietly. It also reduces the locking tendency between rotor and stator.

**Advantages:**

- 1.Simple and rugged construction and can withstand rough handling.
- 2.Low cost of maintenance and repair.
- 3.Good efficiency and power factor.
- 4.Simple star-delta starter is sufficient for starting.

**Disadvantages:**

1. Size of slip ring IM of same capacity is more than squirrel cage IM.
2. Costlier as the construction is complicated.
3. High maintenance cost and repair.

**Applications:**

Used for loads which require high starting torque such hoists, cranes, etc

**Phase wound rotor:**

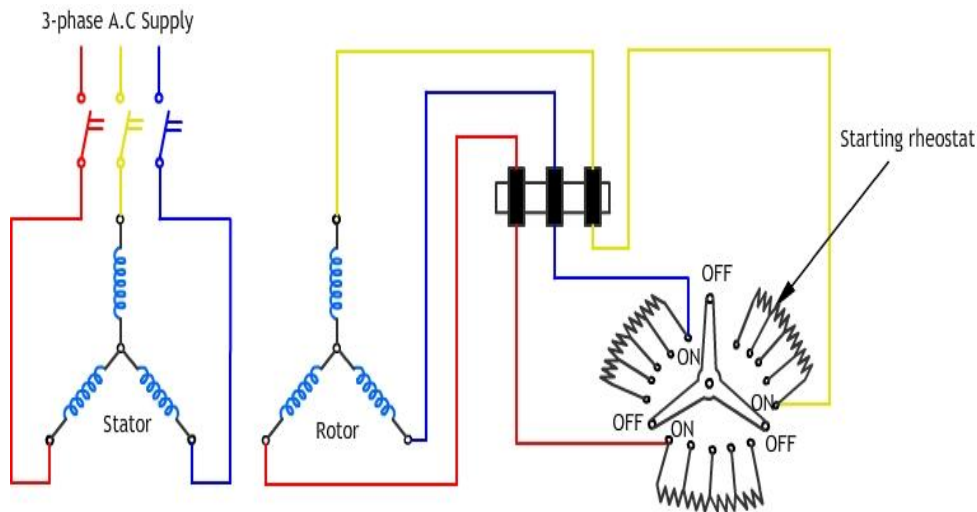

Fig 5.2.2(b): Phase wound rotor [Ref: DSI ppt]

The rotor is laminated, cylindrical having uniform slots on its outer periphery. A 3 phase which is star connected is placed in these slots. The open end of star winding is brought out and connected to 3 insulated slip rings, mounted on the shaft with carbon brushes resting on them. Three brushes are externally connected to 3 phase star connected rheostat which is used as starter. When running under normal conditions the slip rings are automatically short circuited by means of metal collar, which is pushed along the shaft that connects all the rings. Brushes are lifted from slip rings to reduce frictional losses and wear and tear.

**Advantages:**

- 1.Has external resistance in the rotor circuit which is used to start.
- 2.Has high starting torque and low starting current.
- 3.Smooth running motor
- 4.Slip ring IM of very high capacity can be built.
5. Explosion proof due to absence of slip ring and brush.

**Disadvantages:**

- 1.Low starting torque, hence pf is also low.

2.Starting current is high, no smooth running.

**Applications.**

Used for loads which require normal starting torque such as lathes,etc.

**Concept of rotating magnetic field:**

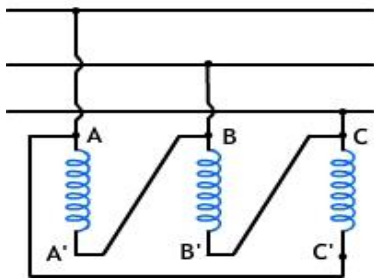

Fig: 5.2.3 (a) Stator

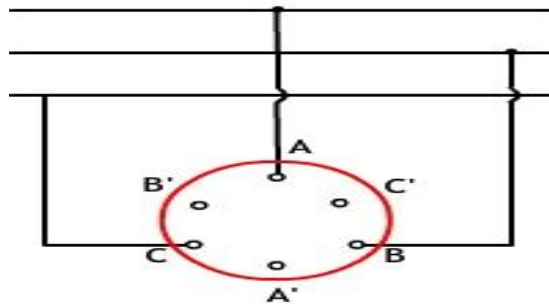

Fig: 5.2.3(b) Rotor.

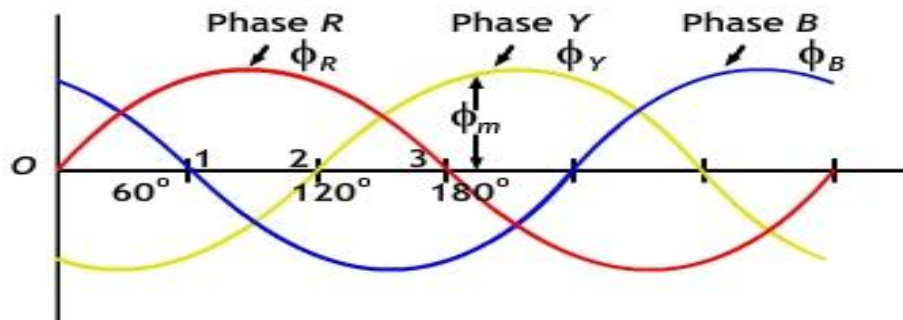

Fig: 5.2.3(c) Three phase waveform [Ref: DSI ppt]

a) At  $\theta = 0^\circ$

This corresponds to point O in the figure of waveforms of phases R, Y and B.

$$\phi_R = 0, \phi_Y = -\frac{\sqrt{3}}{2} \phi_m, \phi_B = \frac{\sqrt{3}}{2} \phi_m$$

$$\therefore \phi_T = 2 \times \frac{\sqrt{3}}{2} \phi_m \cos \frac{60^\circ}{2} = \sqrt{3} \times \frac{\sqrt{3}}{2} \phi_m = \frac{3}{2} \phi_m$$

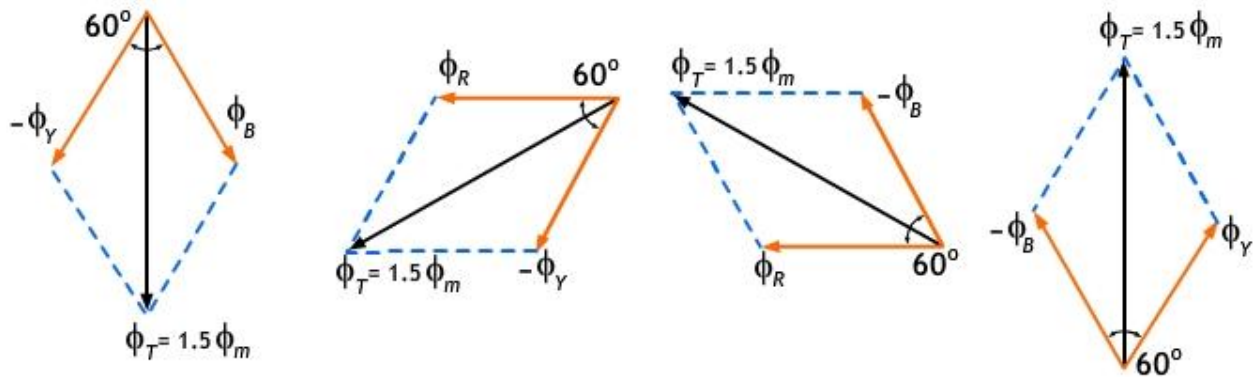

b) At  $\theta = 60^\circ$ , corresponding to point 1 in the figure of waveforms of phases R,Y and B.

$$\phi_R = \frac{\sqrt{3}}{2} \phi_m$$

$$\phi_Y = -\frac{\sqrt{3}}{2} \phi_m \quad \phi_B = 0$$

$$\therefore \phi_T = 2 \times \frac{\sqrt{3}}{2} \phi_m \cos 30^\circ = \frac{3}{2} \phi_m$$

The resultant flux is again  $3/2 \Phi_m$ , but has rotated clockwise through an angle of  $60^\circ$ .

c) At  $\theta = 120^\circ$  i.e. corresponds to point 2 in the figure of waveforms of phases R,Y and B.

$$\phi_R = \frac{\sqrt{3}}{2} \phi_m, \quad \phi_Y = 0, \quad \phi_B = -\frac{\sqrt{3}}{2} \phi_m$$

$$\phi_T = \frac{\sqrt{3}}{2} \phi_m$$

Thus, once again the resultant has the same value, but has further rotated clockwise through an angle of  $60^\circ$ .

d) At  $\theta = 180^\circ$ , i.e. relating to point 3 in the figure of waveforms of phases R, Y and B.

$$\phi_R = 0, \phi_Y = \frac{\sqrt{3}}{2} \phi_m, \phi_B = -\frac{\sqrt{3}}{2} \phi_m$$

The resultant is  $\frac{3}{2} \Phi_m$ , and has rotated clockwise through an additional angle of  $60^\circ$ , or through

an angle of  $180^\circ$  from the beginning. Thus, we come to the following conclusions:

1. The resultant flux is of constant value =  $\frac{3}{2} \Phi_m$ , i.e. 1.5 times the maximum value of the flux due to any phase.
2. The resultant flux rotates around the stator at synchronous speed =  $\frac{120f}{p}$  where P = number of stator poles and f = supply frequency in Hz.

**Working principle:**

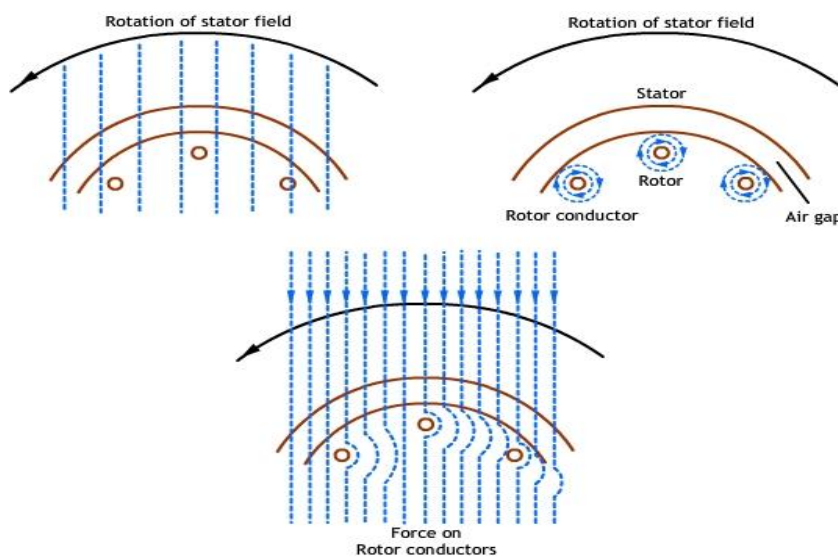

Fig: 5.2.4 Working principle of Induction motor [Ref: DSI ppt]

- When the stator of a 3-phase induction motor is connected to a 3-phase a.c supply, a rotating magnetic field is established which rotates at synchronous speed.
- The magnetic flux of constant amplitude, rotating at synchronous speed, passes through the air-gap and cuts the rotor conductors which are stationary.
- Due to the relative speed between the rotating flux and the stationary conductors an e.m.f is induced in the latter as per Faraday's Laws of Electromagnetic Induction.
- The frequency of the induced e.m.f is the same as the supply frequency. Its magnitude is proportional to the relative velocity between the flux and the conductors, and its direction is given by Fleming's Right-Hand Rule.
- Since the rotor conductors form a closed circuit, rotor current is produced, whose direction in terms of Lenz's Law is such as to oppose the very cause producing it.
- Here, the cause which produces the rotor current is the relative velocity between the rotating field and the stationary rotor.
- Hence, to reduce this relative speed, the rotor starts running in the same direction as the stator field in an effort to catch up with it.
- In figure, the stator field is shown as rotating in an anticlockwise direction.
- The relative motion of the rotor with respect to the stator is clockwise.
- By applying the Right-hand Rule, the direction of the induced e.m.f in the rotor is outwards.
- So, the direction of the flux because of the rotor current alone is as shown in figure.
- Considering the effect of both rotor and stator fields, the rotor conductors are subjected to a force tending to rotate them in the anticlockwise direction.
- Thus the rotor is made to rotate in the same direction as the stator field.
- As discussed earlier the rotor follows the stator field.
- In actual practice, the rotor can never reach the speed of the stator field.
- If it does so, there would be no relative movement between the stator field and rotor conductors, no induced rotor current, and therefore, no torque to drive the rotor.
- Hence, the rotor speed is always less than the speed of the stator field.



- The difference in the speed between stator field and rotor depends on the load.

**Slip:**

- The difference between the synchronous speed  $N_s$  and the actual speed  $N$  of the rotor is called slip speed. (The quantity  $N_s - N$  is sometimes called the slip-speed.)
- It is usually expressed as a percentage of synchronous speed.
- It is apparent that the rotor (or motor) speed is  $N = N_s (1 - S)$ .
- In an induction motor, the change in slip from no-load to full-load is hardly 3 - 6%, so that the induction motor is essentially a constant speed motor

**Frequency of Rotor Current:**

- When the rotor is at standstill, the frequency of rotor current is the same as the supply frequency.
- When there is relative speed between the rotor and the stator field, the frequency of the induced voltage, and hence the current, in the rotor varies with the rotor speed i.e., slip
- Let at any speed  $N$  of the rotor, the frequency of the rotor current be  $f'$ .
- Hence, the frequency of rotor current (or e.m.f) may be obtained by multiplying the supply frequency by fractional slip.

**Rotor Torque:**

The torque  $T$  on the rotor is directly proportional to

Rotor current at standstill,  $I_2$

Magnitude of the rotating flux per stator pole,  $\phi$

$\cos \phi_2$  (p.f. of the rotor circuit)

$\phi_2$  = angle between rotor e.m.f. and rotor current

$T \propto F I_2 \cos \phi_2$

or  $T \propto E_2 I_2 \cos \phi_2$

**Torque-Slip Characteristics:**

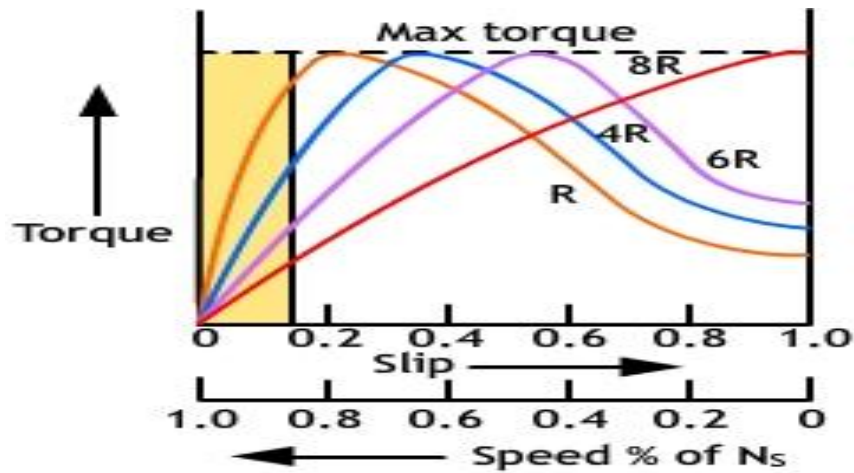

Fig: 5.2.5. Torque –slip characteristics. [Ref: DSI ppt]

- This maximum torque is known as pull-out or breakdown torque.
- When the slip increases beyond that corresponding to maximum torque, the term  $(sX_2)^2$  increases very rapidly  $R_2^2$  may be neglected as compared to  $(sX_2)^2$ .
- Thus, the torque is now inversely proportional to slip, and the torque-slip curve is a rectangular hyperbola.
- We see that any further increase in motor load beyond the point of maximum torque, results in decrease of torque developed by the motor.
- As a result, the motor slows down and ultimately stops.
- So, stable running of the motor lies between the values of  $s = 0$  and that corresponding to maximum torque.

**Starters for 3-Phase Induction Motors:**

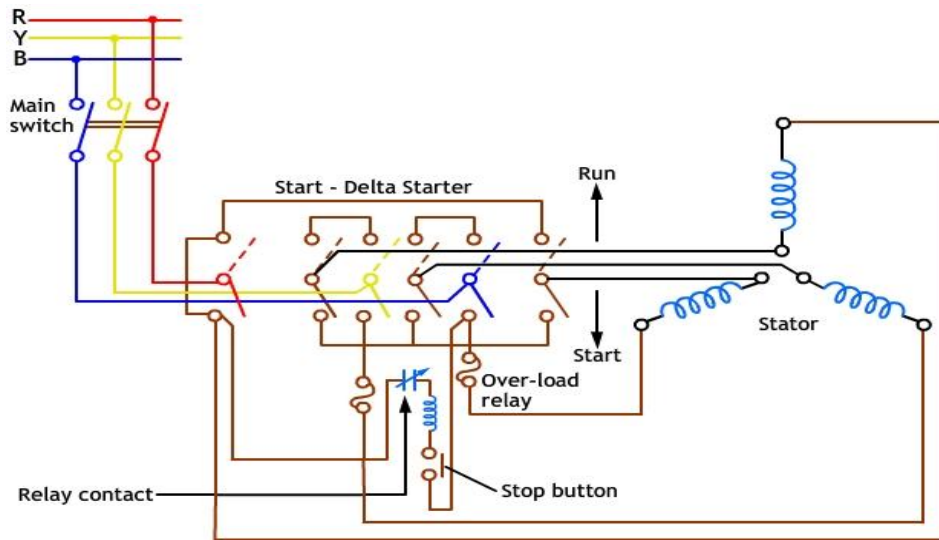

Fig: 5.2.6. Star –delta starter. [Ref: DSI ppt]

- During the normal operation of the motor, it has the full rated voltage applied across it.
- However, at the time of starting, it draws about 5 to 7 times the full load current and produces only 1.5 to 2.5 times the full load torque, when it is directly connected to the supply.
- This large initial surge of current is due to the absence of back emf during starting.
- This large starting current is objectionable, as it is sure to cause damage to the motor; besides it causes large line drop, adversely affecting the operation of other connected apparatus to the line.
- Hence, in the case of a squirrel cage induction motor, where the rotor of the motor is permanently short-circuited, a reduced voltage is applied at starting, and the voltage is increased to the rated value, when the motor has picked up speed. The reduced voltage is obtained by using a starter.
- In the case of slip-ring induction motors, resistance can be included in the rotor circuit during starting and can be removed when the motor picks up speed.
- Squirrel–cage motors are generally started by operating the changeover switch of a star-delta starter.
- The starter connects the three stator windings in star at the instant of starting and as the motor picks up the normal speed, the starter is switched over to the running position, to connect the stator windings in delta.

- The voltage of each phase at starting is reduced by factor of  $1/\sqrt{3}$ .
- The current in each phase is also reduced by the same factor. Thus, the line current during starting is of the current which the motor would have taken if it had been directly connected across the mains supply.
- As  $T \propto V^2$  the starting torque is reduced.
- The changeover switch is of the double-throw type, with interlocks to prevent the motor from starting when the switch is in the RUN position.
- An overload relay is provided, whose contact will open in the event of overload, stopping the motor as supply to one of the stator windings is disconnected.
- An under voltage coil is incorporated, so that if the supply voltage falls below a particular value, the stop button will be operated and supply to a stator phase will be disconnected, again bringing the motor to halt.
- The stop button can also be manually operated, in order to stop the machine.

### Problems:

1. A 3-phase, 4-pole, 400 V, 50 Hz induction motor runs with a speed of 1440 rpm. Calculate its slip.

### Solution:

$$\text{Synchronous speed, } N_s = \frac{120f}{P} = \frac{120 \times 50}{4} = 1500 \text{ rpm}$$

$$\text{Rotor speed } N = N_s (1 - s)$$

$$1440 = 1500 (1 - s) \quad \text{or} \quad \text{Slip 's'} = 0.04 \quad \text{or} \quad 4\%$$

2. The frequency of the emf in the stator of a 4-pole induction motor is 50 Hz and in the rotor is 1.5 Hz. What is the slip and at what speed is the motor running?

**Solution:**

Synchronous speed,  $f' = sf$  or  $1.5 = s \times 50$   
 $\therefore s = 0.03$  or  $3\%$

$$N_s = \frac{120f}{P} = \frac{120 \times 50}{4} = 1500 \text{ rpm}$$

Rotor speed,  $N = N_s (1 - s)$   
 $= 1500(1 - 0.03)$   
 $= 1455 \text{ RPM}$

