

Basic Wiring for Motor Control

Technical Data

New Information
April 2007

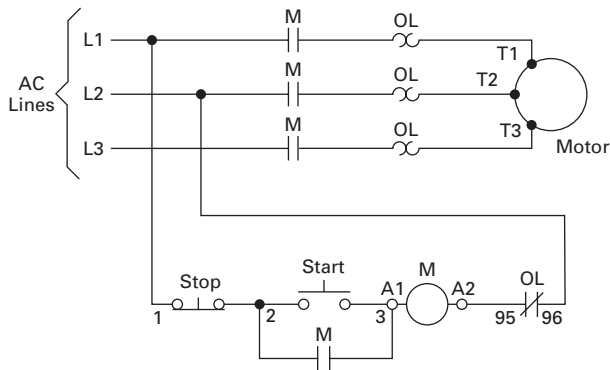

Table of Contents

<i>Description</i>	<i>Page</i>
Language of Control	2
Symbols	3
Circuitry of a Starter	4
Two-Wire Control	6
Three-Wire Control	6
Control Power Transformers	8
Control Circuit Wiring of CPTs	9
Reversing Starters	10
Cover Control Circuits	11
Start/Stop with Pilot	11
Hand/Off/Auto	11
Forward/Reverse with 2 Pilots	12
Glossary	13

Introduction

A Refresher Course for the Product Modifier

This text is designed as a refresher course for personnel who will have the responsibility of modifying Cutler-Hammer® products from Eaton's electrical business to meet their customer's needs.

The scope of the material has been necessarily limited. It covers the most commonly used products and wiring schematics. Despite its brevity, you are cautioned not to skim lightly over the content.

The Benefit of Satisfaction and Confidence

There is great satisfaction in being "good" at something. Individuals who attain knowledge in a particular field have confidence and the respect of their associates.

Studying this text will provide you with a fundamental and solid knowledge of control wiring and the products you will be working with.

When you are able to offer your customers tailor-made solutions to their product needs, you are sure to feel great satisfaction. And, when your endeavors help add to the profitability of your organization, you will very likely enjoy greater benefits.

We hope you agree after finishing this course of study.

Language of Control

Circuit diagrams communicate information quickly and efficiently.

Every trade and profession has its method of communicating ideas and information quickly and efficiently. In addition to the terminology shown in the glossary of this text, diagrams play a vital role of communication in electrical circuits. A knowledge of symbols, diagrams and terminology will aid in our understanding of electrical control.

The basic language of control is the circuit diagram. Consisting of a series of symbols interconnected by lines to indicate the flow of current to the various components, it tells in remarkably short time a series of events that would take many words to explain. Circuit diagrams are available in two formats.

Wiring diagrams show the connections to the controller.

Wiring diagrams, sometimes called "main" or "construction" diagrams, show the actual connection points for the wires to the components and terminals of the controller. They show the relative location of the components. They can be used as a guide when wiring the controller.

Figure 1 is a typical wiring diagram for a three-phase magnetic starter.

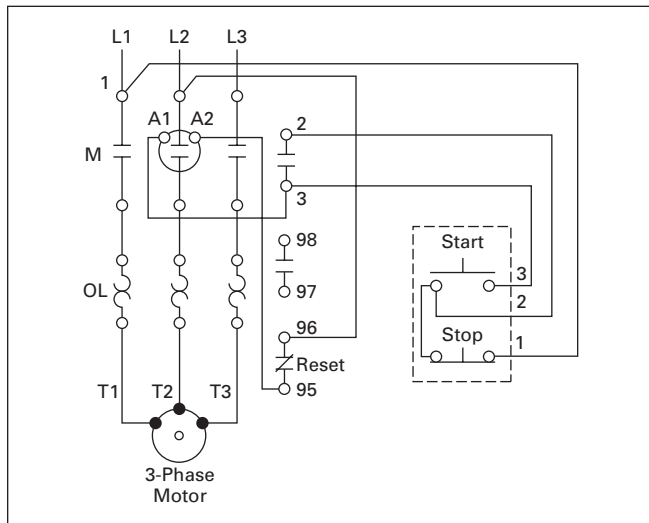

Figure 1. Typical Wiring Diagram

Line diagrams show circuits of the operation of the controller.

Line diagrams, also called "schematic" or "elementary" diagrams, show the circuits which form the basic operation of the controller. They do not indicate the physical relationships of the various components in the controller. They are an ideal means for troubleshooting a circuit.

Figure 2 shows a typical line or schematic diagram.

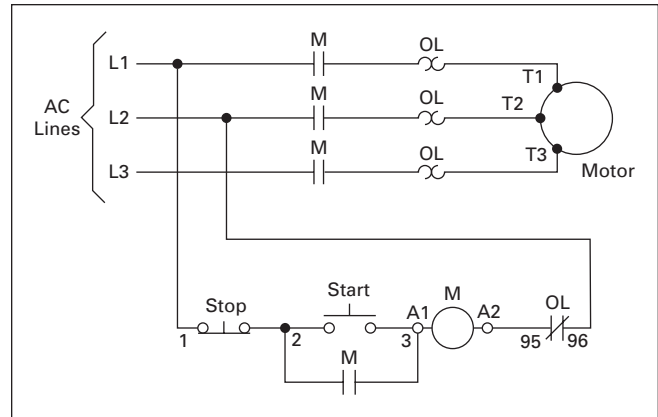

Figure 2. Typical Line or Schematic Diagram

Symbols

Standardized symbols make diagrams easier to read.

Both line and wiring diagrams are a language of pictures. It is not difficult to learn the basic symbols. Once you do, you are able to read diagrams quickly, and can often understand a circuit at a glance. The more you work with both line and wiring diagrams, the better you will become in analyzing them. The American Standards Association (ASA) and the National Electrical Manufacturers' Association (NEMA) are the agencies which are responsible for setting up and maintaining the symbol standards. Because of these standards, you will be able to read all diagrams that come across your workbench.

Figure 3 shows many of the most commonly used symbols on Control diagrams.

On Contacts and Switches or Pushbuttons, you will find a designation of NO or NC (Normally Open or Normally Closed). This refers to the state of the contacts when power is not applied to them. In tracing circuits on line diagrams, you will need to visualize the opening or closing of the contacts when the circuit is energized or de-energized.

The pushbutton symbols shown in **Figure 3** represent "Momentary" pushbuttons. The contacts will change state from their normal position only for as long as your finger is on the button.

Later in this text, we will be working with actual applications and line diagrams. So study these symbols carefully please.

Coils	Single Voltage Magnet Coils	
	Dual Voltage Magnet Coils	
Contacts	Normally Open	
	Normally Closed	
	Timed Open	 T.O.
	Timed Closed	 T.C.
Fuse	Standard	
Indicator Lights	Standard	 A-Amber R-Red G-Green B-Blue
Motors AC	Single-Phase	
	Three-Phase	
Relays	Thermal Overload	
	Time Delay	
Switches	Pushbutton	 Normally Closed
	Pushbutton	 Normally Open
	Limit Switch Normally Open	
	Limit Switch Held Open	
	Limit Switch Normally Closed	
	Limit Switch Held Closed	
	Selector Switch Two-Position	 Jog Run
Selector Switch Three-Position	 Hand Off Auto	
	Two-Wire Pilot Devices	
Transformers	Low Voltage Control Transformer	

Figure 3. Standard Diagram Symbols

Circuitry of a Starter

The two circuits of a motor starter are the power and control circuits.

There are two circuits to a starter — the **Power Circuit** and the **Control Circuit**.

The electricity that passes through the contacts of the starter, through the overload relay, and out to the motor, is called the power circuit. The thick lines of **Figure 4** represent this power circuit. It is the power circuit that passes electricity to the motor enabling it to run. For this reason, it is sometimes referred to as the motor circuit.

Common Control — power and control circuits at same voltage. **Separate Control** is at different voltages.

The thin lines in **Figure 4** represent the control circuit. The magnet coil of the starter is energized with this circuit, which creates the electro-magnetic field that pulls the power circuit contacts closed.

The control circuit is separate from the motor circuit. The control circuit may not be at the same voltage as the power circuit. When the voltage of the control and power circuits is the same, it is referred to as **Common Control**. If the voltages are different, it is called **Separate Control**.

Separate voltages supplied by Control Power Transformers.

Another method for supplying separate voltages for power and control circuits, is to use a Control Power Transformer. These are sometimes also referred to as Control Circuit Transformers. One voltage source is used to supply the motor. This same voltage is also supplied to the primary side of the transformer. The transformer's secondary supplies the voltage to operate the magnet coil in the control circuit. A more detailed explanation of transformers can be found on **Page 8**.

Common Control is when the power circuit and the control circuit are fed from the same voltage source.

Common control is when the control circuit is tied back to lines 1 and 2 of the starter. It is supplied with the same voltage as the power or motor circuit.

The understanding of Common Control and Separate Control becomes significant when changing magnet coils from one voltage to another.

Changing magnet coils from 120V or to 120V involves adding or removing wire "C".

If you stock starters or contactors with different rated magnet coils, and need to convert the device to a 120V magnet coil for separate control, you must remove the connection to the power circuit that is provided. **Figure 5** shows this connection. Wire "C" is connected to L2 and terminal 96 on the overload relay in all Cutler-Hammer starters supplied with magnet coils greater than 120V. You must remove the wire, and then connect the separate control voltage lines to the number 1 terminal on the remote pilot device and terminal 96 on the overload relay.

On the other hand, if you are converting a starter that was factory supplied for 120V Separate Control to a Common Control device, you must put in this jumper.

If you are swapping out a 480V magnet coil to supply one with 240V coil to meet a customer's needs, you do not need to worry about wire "C". Only when changing to 120V or less from any voltage greater than 120V or changing to any voltage greater than 120V from 120V or less, is this significant.

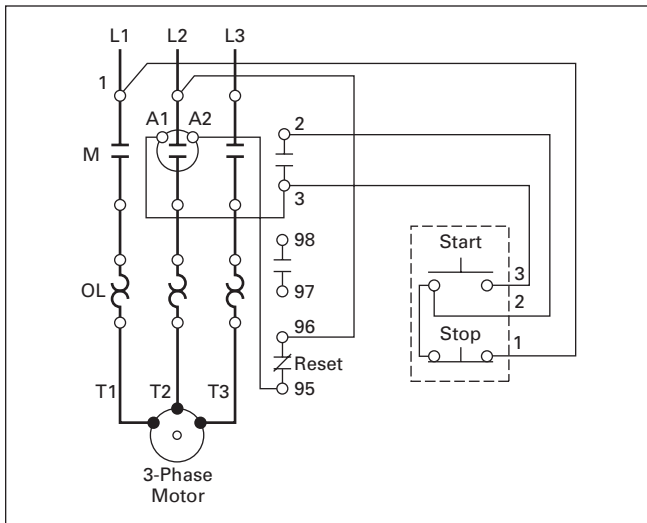

Figure 4. Typical Starter Wiring Diagram — Three-Phase

Separate voltages supplied by different voltage sources.

How can you have two different voltages going into the same starter? One method is to run different wires from different electrical voltage sources. You might have a 480V supply that is attached to the line side of the starter, and that runs through to the motor. Another set of wires, from a different voltage source would bring 120V to the magnet coil. The coil is energized by the 120V, and the pushbuttons or other control devices operate at this same voltage. The motor operates at the power circuit voltage, in this case, 480V. The coil rating must match the control source voltage, and the starter is sized to match the horsepower and voltage ratings of the power circuit.

Circuitry of a Starter

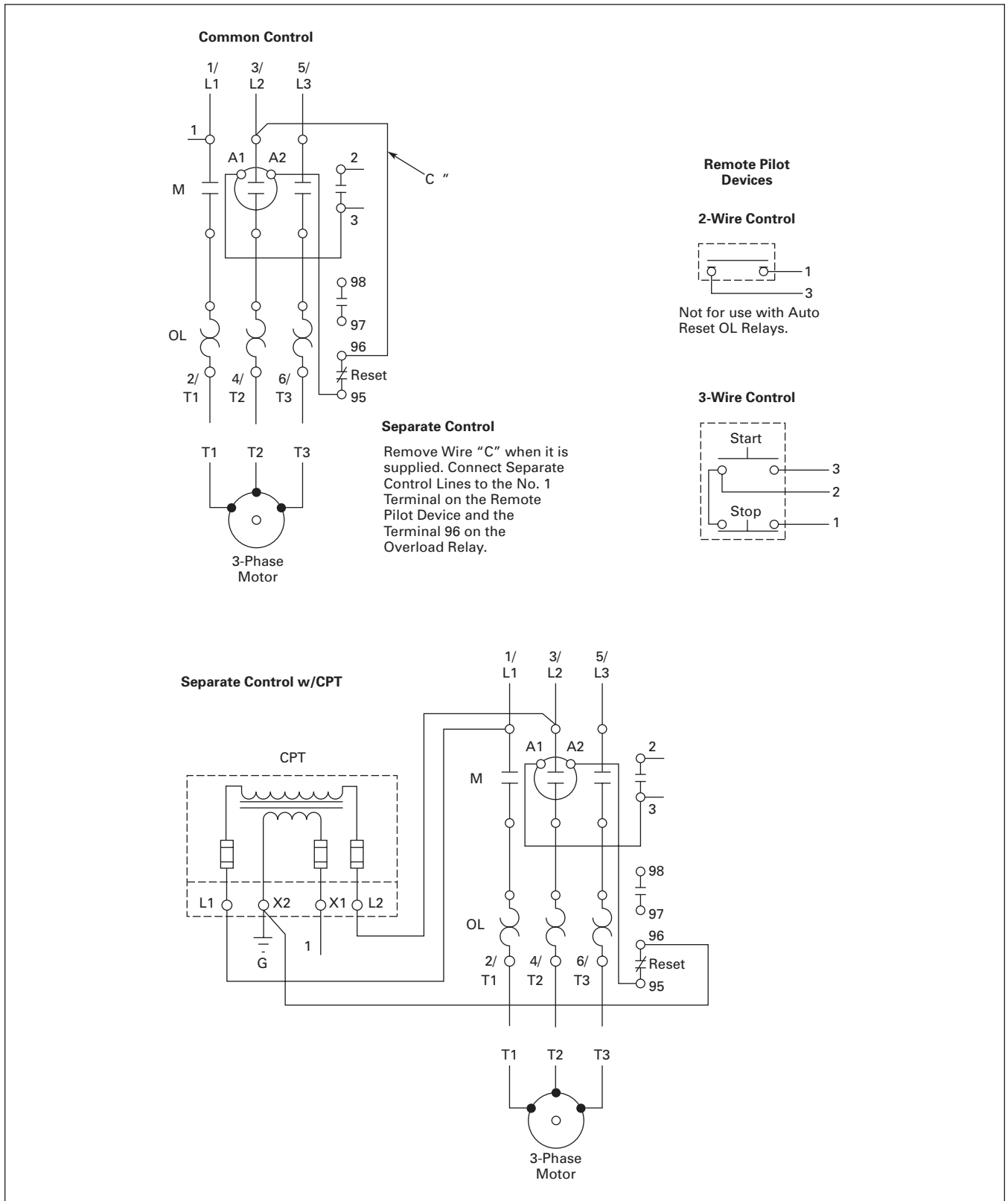

Figure 5. Common vs. Separate Control

Circuitry of a Starter Two-Wire Control

Two-Wire Control circuits — or Low Voltage Release

One of the common control wiring circuits used is known as Two-Wire or Low Voltage Release (LVR). It utilizes a main-tained contact type of pilot device — such as a thermostat, float switch or presence sensor. **Figure 6** shows the line and wiring schematics for this circuit.

When the maintained contacts on the pilot device are closed, it energizes the coil of the starter, which connects the load through the power circuit. When the contacts of the pilot device open, the coil is de-energized, and the starter drops the load off line.

Automatically restarts when power is restored if pilot device is still closed.

The circuit provides for an automatic operation of the load. If there is a power outage or loss, the starter will be de-energized. This is why the circuit is often called Low Voltage Release (LVR).

If the maintained contacts of the pilot device remain closed during the power loss or outage — the starter will be re-energized when the power to the control circuit is restored.

Caution must be used in the application of this circuit — there is no personnel safety protection when the power is restored.

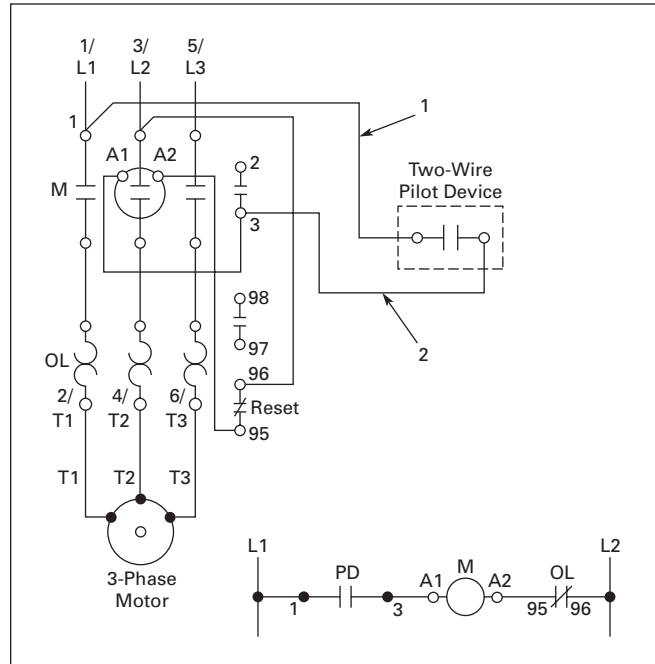

Figure 6. Two-Wire Control

Three-Wire Control

Three-Wire Control circuits — or Low Voltage Protection

The other very common control wiring circuit used is known as Three-Wire or Low Voltage Protection (LVP). This circuitry does provide personnel safety protection in the event of power loss or outages. It utilizes momentary contact pilot devices and a holding circuit contact.

This holding circuit, or seal-in circuit, is most commonly provided by an auxiliary contact on the contactor or starter.

Figure 7 shows the typical line and wiring diagrams for Three-Wire control circuits.

Circuit does NOT automatically restart when power is restored.

This circuitry provides LVR, because if there is a power outage or loss, the starter will be de-energized. But, it provides Low Voltage Protection, because the circuit does not automatically restart. The only way to restart this circuit is to manually use the START button.

Because this circuit is very popular in motor control systems, let's go through the operation of it step-by-step.

The circuit consists of a Normally Closed (NC) STOP button wired in series with a Normally Open (NO) START button. A Normally Open (NO) Auxiliary contact on the starter will be used as the holding circuit.

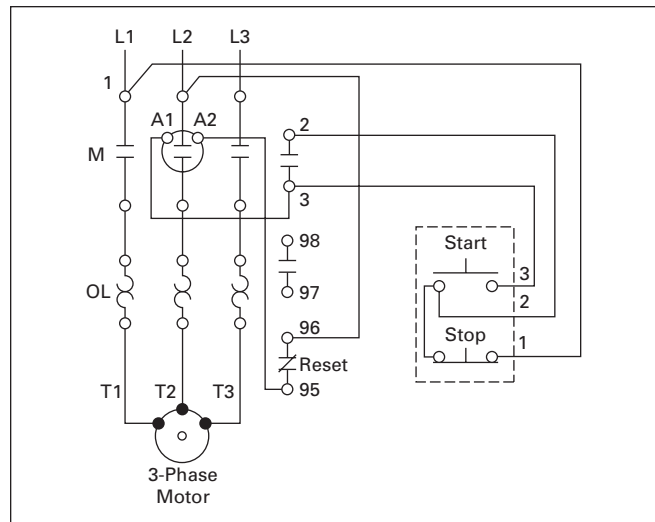

Figure 7. Three-Wire Control

Circuitry of a Starter

Three-Wire Control (Continued)

When the START button is depressed (**Figure 8**), it completes the circuit to energize the coil of the starter. When that occurs, the Normally Open (NO) Auxiliary contact closes. This auxiliary is shown as | M on the line diagram.

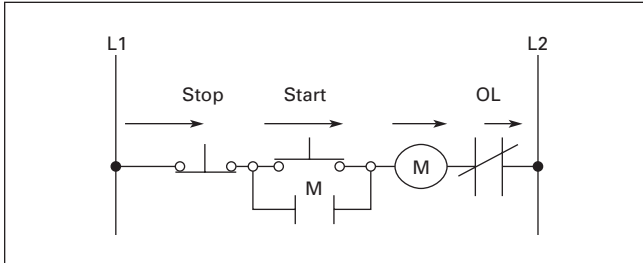

Figure 8. START Button Completes Circuit

When you remove your finger from the START button, its contact returns to the Normally Open state. Even though this opens a path to the coil, the circuit now travels through the closed M contact to keep the starter energized.

The electricity flows from L1, through the Stop (NC), through the path completed when contact M closed, to the coil, through the overload relay control circuit, to L2 (**Figure 9**).

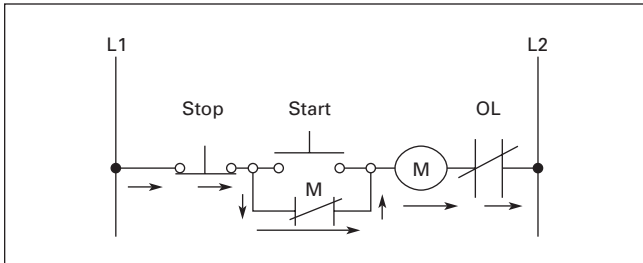

Figure 9. Electrical Path is through Contact M

Pressing the STOP (**Figure 10**) button will cause the Normally Closed (NC) contact to open the circuit, de-energize the coil, and drop out contact M. Releasing the STOP button will return the circuit to its original (off) state.

If there is a power outage or loss, the coil is de-energized, contact M opens, and the starter drops the load off line.

When power is restored, the circuit CANNOT automatically restart because the START button needs to be pushed to complete the circuit. Because someone must manually restart the circuit, this can provide a means of personnel safety.

As we saw in the common vs. separate control wiring, the control circuit is connected through a contact on the overload relay. When an overload is detected, this contact opens the circuit and de-energizes the coil. If you are using a Three-Wire control circuit, then the starter cannot automatically restart — the Start button with its NO contacts prevent the circuit from being completed.

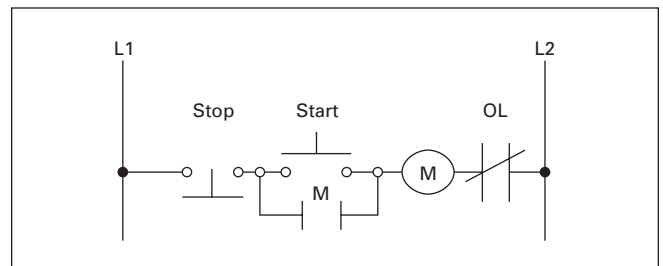

Figure 10. STOP Button Opens Circuit

With 3-Wire control, automatic reset on an overload relay will NOT re-energize the circuit.

There is sometimes confusion with overload relays that have an Automatic Reset capability.

In a Three-Wire circuit, with the overload relay set for Manual Reset, both the RESET button on the overload, as well as the START button, must be used to re-energize the circuit.

An overload relay in the Automatic mode would not automatically re-energize the circuit, because the START button is still open.

An overload relay with Automatic Reset, used with a two-wire circuit would provide automatic restart. This type of circuitry must be used only on applications where personnel safety is not an issue.

Control Power Transformers

Why use a Control Power Transformer?

The motor branch circuit is usually a segment of a larger electrical distribution network in an industrial plant. The motor circuit supplies the required power to the various control devices in order for them to operate. In some cases, the various control devices are operated at the same voltage as the motor. Sometimes, the voltage required to operate the motor is too high to safely operate the control circuit, particularly in regards to personnel safety. As a means of reducing the motor voltage to a safer control voltage level, we use a device known as a Control Power Transformer.

Connected with the Primary winding to the Power circuit — Secondary winding to the Control Circuit.

A typical control transformer is shown in **Figure 11** below. It consists of two separate coils of wire (windings) placed adjacent to each other on a common iron core. Note that the primary winding is connected to the power source. The secondary winding is connected to the control circuit. The purpose of the transformer is to transfer electric power from the primary circuit to the secondary circuit. The transformer either reduces (steps down) or increases (steps up) the voltage to match the requirements of the control circuit.

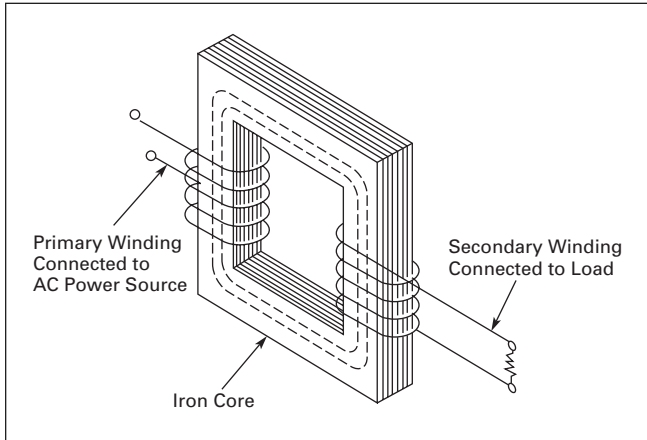

Figure 11. Typical Control Transformer

Magnetic field from primary winding induces voltage in the secondary winding.

Applying AC voltage to the primary winding of the transformer causes alternating current to flow in the winding. This produces a magnetic field that extends outside the winding, in the shape of concentric loops as shown in **Figure 12**. The magnetic field fluctuates as the AC changes direction. These magnetic lines cut across the conductors of the secondary winding and induce a voltage.

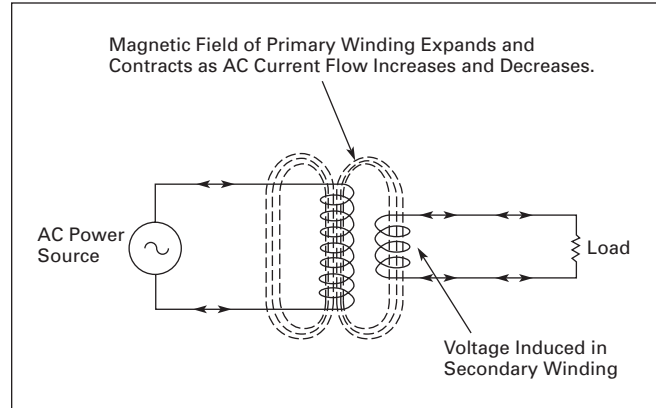

Figure 12. AC Flow in Windings

Voltages based on number of turns on both windings.

The relationship of the voltage across the primary to the voltage across the secondary is in direct proportion to the number of turns on both windings. For example, 100 turns on the primary, and 10 turns on the secondary, is a 10 to 1 ratio. If the primary is 500 volts, we will get 50 volts at the secondary. This is referred to as a Step-Down transformer. They are most commonly used in control circuits where the motor voltage is 480V, 600V, or higher. The step-down control transformer would reduce the voltage to pushbuttons or PLCs to 120V or even 24V.

A transformer with the reverse proportion of more turns on the secondary winding than on the primary is called a Step-Up transformer. It will increase the voltage according to the ratio of turns.

Control Power Transformer

Primary connects to the power circuit — Secondary connects to the control circuit.

The schematic symbol for the transformer is represented by two groups of “scallops” facing each other. These represent the primary and the secondary windings. The winding with the higher number of turns should be shown to have more scallops than the other to identify it as either a step-down or step-up transformer.

Figure 13 shows a basic control circuit with a step-down transformer added. Note that the main motor circuit operates at 480V, while the control circuit is at 120V.

The primary winding of the transformer is connected to two phases of the power circuit. The secondary winding is connected to the control circuit.

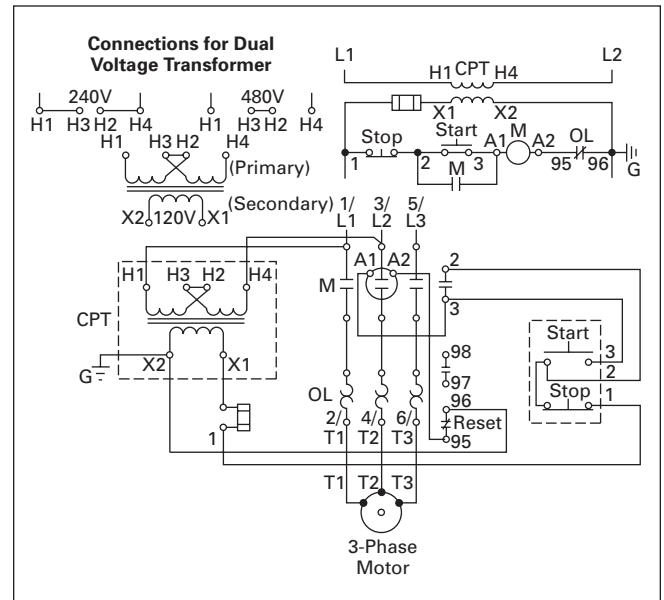

Figure 13. Control Circuit with CPT

Control Circuit Wiring of CPTs

Magnet Coil and Pilot Lights rated for same voltage as Secondary of Transformer.

When you are installing a Control Power Transformer into a starter, you must be sure that the magnet coil is rated for the same voltage as the secondary of the transformer.

In addition, any pilot lights in this circuit must have the same voltage as the secondary.

Dual Voltage units shipped with connections made for the higher voltage.

When you are using a Control Power Transformer with a dual voltage primary, check the transformer connections to be sure that they match the voltage of your power source.

Cutler-Hammer transformers with dual voltage primaries (i.e. 480V and 240V) are shipped with the transformer connections made to supply the higher voltage. If the lower primary voltage is required for your application, change the connections as shown on the nameplate of the transformer.

Remove wire “C”, if supplied, from starter’s control circuit.

As discussed earlier in this booklet, if wire “C” is supplied on the starter (magnet coil voltages greater than 120V), you must remove it. This will convert the starter from Common Control to Separate Control.

The leads from the primary of the transformer are connected to L1 and L2 on the starter. In this way, the primary of the transformer is supplied with the same voltage as the power/motor circuit of the starter.

The leads from the secondary of the transformer are connected to Terminal 1 of the remote pilot device, and terminal 96 on the Freedom Series overload relay (see **Figure 14**).

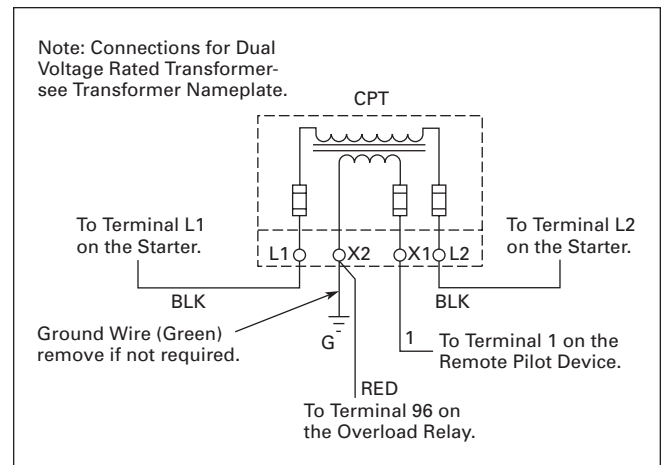

Figure 14. CPT Wiring Diagram

Reversing Starters

To reverse a motor, you reverse the leads to the motor.

To reverse a motor, you need to reverse the leads to the motor. When using a reversing magnetic starter, this task is accomplished using two contactors, one overload relay, and a mechanical interlock. The control circuit is designed to provide an electrical interlock as well.

Both the mechanical and electrical interlocking prevent the simultaneous operation of the forward and reverse contactors.

Figure 15 shows the wiring diagram for a full-voltage magnetic reversing starter.

When the forward contacts (F) close, L1, L2, and L3 are connected to T1, T2, and T3, just as they would be on a non-reversing starter.

When the reverse contacts (R) close, the motor is connected L1 to T3, L2 to T2, and L3 to T1. On a three-phase motor, it is necessary to change only two leads in order to reverse the rotation of the motor.

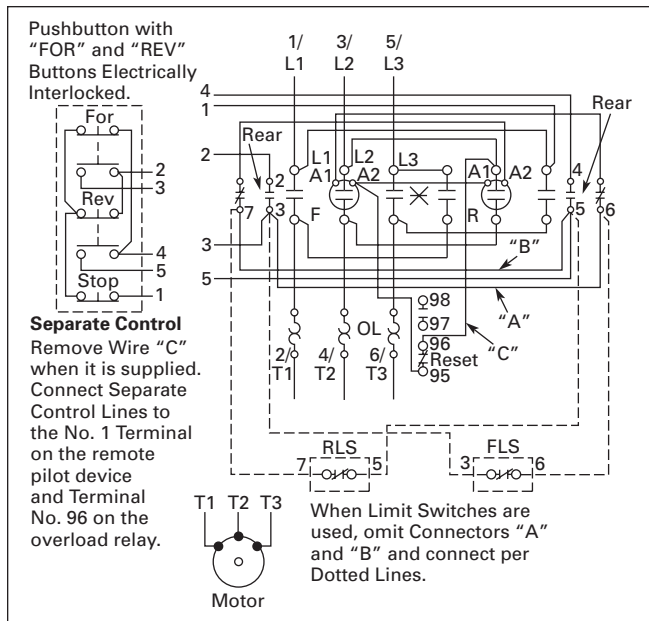

Figure 15. Reversing Starter Wiring Diagram

Mechanical Interlock prevents simultaneous operation.

To keep the forward and reverse contacts from operating simultaneously, a mechanical device is used.

This device mounts in between the two contactors and physically prevents the power contacts from operating at that same time.

Control circuitry provides an electrical interlock to prevent operation at the same time.

Additionally, the control circuits are wired in such a way as to prevent simultaneous operation. This is done with the use of Normally Closed (NC) auxiliary contacts.

As the coil of one direction contactor is energized, its associated NC contact opens — insuring an open electrical path to the coil of the opposite contactor's coil. Figure 16 shows this circuitry.

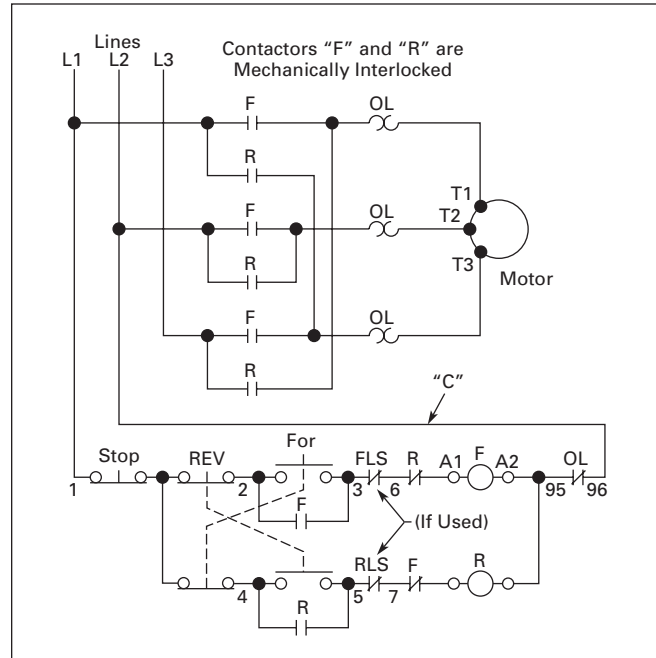

Figure 16. Reversing Starter Line Diagram

This circuit operates as follows: Depressing the FORWARD pushbutton energizes coil F, completing the circuit from L1 to L2.

Coil F energizes NO auxiliary contact F, closing it for the holding circuit.

Coil F also operates NC auxiliary contact F, opening it to insure that coil R cannot be energized.

The mechanical interlock physically prevents the power contacts of contactor R from operating.

When the STOP button is pushed, the entire circuit is de-energized. All of the contacts return to their normal state.

The REVERSE pushbutton can then be depressed to operate the reverse contactor.

Pressing the REVERSE button allows current to energize coil R to complete the circuit to the motor. Power can flow through NC contact F, since coil F is not energized. When coil R is energized, NO contact R acts as the seal-in contact.

In this control circuit, the STOP button must be operated before the direction of the motor can be changed.

The power circuit connections reverse the rotation of the motor.

Refer back to the wiring diagram (Figure 15). Trace the power circuit lines connected to Coil R.

A connection at L1 is traced through the power contacts, and connected to T3, through the overload relay and to the motor.

The connection at L3 is traced through to be connected at T1.

L2 is connected to T2 as it would be in a non-reversing starter.

It is these connections that reverse the rotation of the motor.

Cover Control Circuits

There are many basic control circuits.

We will be reviewing many basic control circuits. We will look at both the wiring diagram and the line diagram, and discuss their operation. In some cases, alternative circuits will also be demonstrated.

Understanding these circuits will be very helpful to you when installing cover control kits to meet your customer's control needs.

Many of the circuits have their basis in the Three-Wire circuit.

On Pages 6 and 7, we discussed the standard STOP/START circuit. We saw that using a maintained contact pilot device gave us automatic control. Then we looked at a three-wire circuit using momentary contacts and an auxiliary contact to hold the circuit closed.

Many of the control circuits we will discuss in this chapter, will have their basis in this three-wire STOP/START circuit.

One very common variation to this circuit is the addition of a pilot light. In Figure 17 the pilot light will be on when the motor is running. The circuit operates as follows: The START button energizes Coil M, and power passes through the NC contact of the overload relay to L2. Power is also supplied to the Pilot light. When the coil is energized, holding contact M closes, and allows power to continue to pass to the indicating light. As long as the motor is on, the pilot light will be energized.

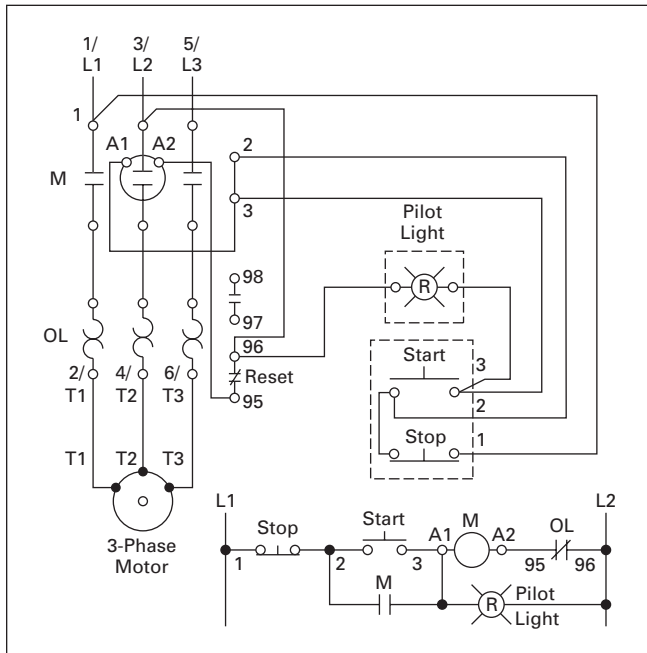

Figure 17. START/STOP with Pilot Light ON When Motor Running

A variation to this circuit is to have a pilot light indicate that the motor is NOT running. Figure 18 shows this circuit. It operates as: There is a standard Three-Wire STOP/START circuit. An additional auxiliary contact on the starter is what operates the pilot light. Notice that it is an NC contact. When the coil is energized, this contact will open. At that point, the pilot light will turn off. When the starter is not energized, this

contact is closed, allowing power to pass from L1 to L2. When the motor is off, the light is on — when the motor is on, the light is off. When wiring this circuit on enclosed controllers, remember that a NC auxiliary contact is needed in addition to the standard NO auxiliary contact.

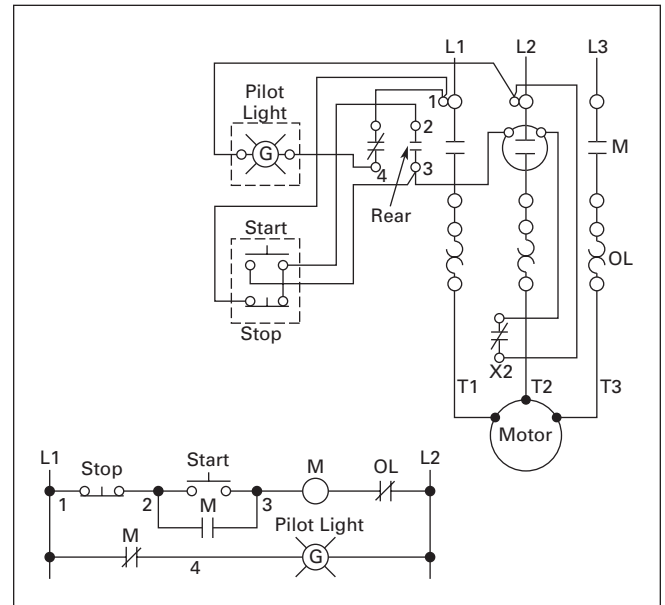

Figure 18. START/STOP with Pilot Light OFF When Motor Running

Another very common control circuit is the HAND/OFF/AUTO (HOA). It can be accomplished using either a three-position selector switch, or three maintained pushbuttons.

Figure 19 shows this circuit.

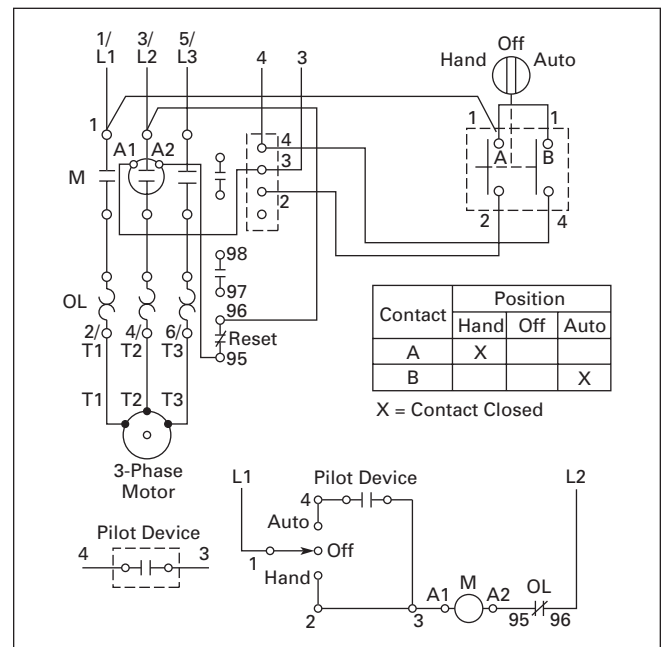

Figure 19. HAND/OFF/AUTO Circuit

Cover Control Circuits

How the HOA circuit works.

It operates: Power from L1 passes to the Hand position (when set for that mode), energizes the coil, passes through the overload relay contacts to L2. The Off position de-energizes the circuit. If the switch is set for the Auto position, power from L1 must first pass through the automatic device (such as a thermostat) before power reaches the coil. If the contacts on the remote device are closed, the Auto position allows the coil to energize. The circuit is on whenever the remote device is closed.

Reversing circuit with Two Pilot lights to indicate operation direction.

On **Page 10**, we discussed the operation of a reversing circuit. In **Figure 20** we show this same circuit, but with the addition of two pilots to indicate the direction in which the motor is operating.

The circuit works as follows: The NC-STOP button allows for power to pass from L1. Pushing the FORWARD button closes the NO contacts and energizing coil F, at the same time, NC contacts F open and prevent Coil R from energizing. (The electrical interlock of the circuit.) Additionally, the power is also passed through the circuit to Pilot Light FOR indicating that the motor is in the forward mode of operation.

The circuit operates the same when the REVERSE button is operated, energizing the REV indicating light instead. Mechanical as well as electrical interlocking prevent the simultaneous operation of the motor direction.

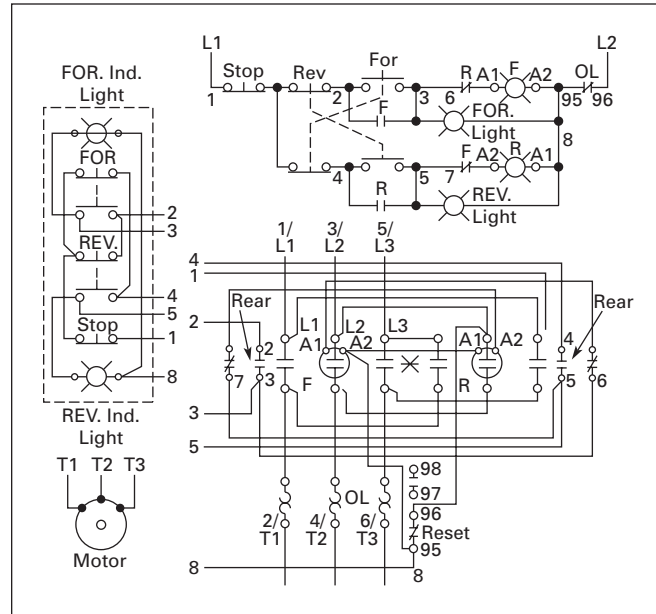

Figure 20.2 Pilot/FORWARD/REVERSE Circuit

Additional examples and explanations of control circuits can be found in Eaton's *Standard Motor Control Line & Wiring Diagrams*, publication number TD03309001E.

This publication is available to you at no charge from your local sales office.

Glossary

Some of the Terminology of Motor Control

Across-the-Line: A method of motor starting that connects the motor directly to the supply line on starting or running. Also known as Full-Voltage.

Auxiliary Contact: Contact of a switching device within the control circuit, and operated when the magnet coil is energized.

Bimetal: Two different metals bonded together to provide fast heat transfer to trip contacts. Used in thermal overload relays.

Common Control: Electricity to both Power circuit and Control circuit are supplied from the same voltage source. See **Page 4**.

Contact: A device to repeatedly establish or interrupt an electric power circuit.

Control Circuit: A circuit that controls the magnet coil of a contactor or starter, and operates pilot devices connected to it. See **Page 4**.

Control Circuit Transformer: See Control Power Transformer

Control Power Transformer: A device that increases or decreases voltage to a desired level to operate the control circuit. See **Page 8**.

De-energize: To disconnect a component or circuit from the power source.

Energize: To apply voltage to an electrical device.

Eutectic Alloy: A solder-like substance used in some thermal overload relays to provide heat transfer to trip the contacts. Converts from a solid to a liquid state at specific recurring points.

Full Voltage Control: Connects the equipment directly to line supply on starting. Also known as Across-the-Line.

Jogging (Inching): Momentary operation, small movement of driven machine or motor.

Ladder Diagram: A schematic diagram where all the components are in a ladder form, up and down picture, to show function of circuit, regardless of physical location of devices. Also known as a Line Diagram. See **Page 2**.

Line Voltage: The voltage being supplied to the equipment from the power supply.

Load: Electrical devices that consume electricity to do useful work, such as motors, solenoids, lights, etc. The output of a motor circuit.

Low Voltage Protection (LVP): Also known as three-wire control, providing non-automatic restart during power loss or failure. Circuit must be manually restarted upon restoration of power. See **Page 6**.

Low Voltage Release (LVR): Also known as two-wire control. Provides a means to automatically restart a control circuit upon restoration of power from loss or failure mode. See **Page 6**.

Normally Closed: The position of a set of contacts that are closed when the device has no electricity applied to it.

Normally Open: The position of a set of contacts that are open (separated) when the device has no electricity applied to it.

Open Circuit: A circuit without a complete path for the electricity to flow through.

Overload Relay: A device designed to protect a motor by sensing the heat from excessive amperage draw of a jammed or overworked motor, and dropping the devices off-line (open circuit) before damage occurs. Often uses either a bi-metal element or a eutectic alloy to sense the thermal changes in the power circuit.

Parallel Circuit: An electrical circuit that has more than one path for current flow. (Connected rungs on a ladder diagram.)

Plugging: Braking of a motor by reverse line voltage or phase sequence. Motor develops retarding force.

Power Circuit: Also known as the Motor Circuit. The electrical path that passes electricity to the motor enabling it to run. See **Page 4**.

Reduced Voltage Starter: Applies a reduced voltage or current supply to the motor during starting to avoid excessive inrush.

Rotor: The rotating part of an electric motor.

Schematic Diagram: A diagram that lays out the control system circuit by circuit, and is composed of symbols and lines representing the functions of devices regardless of their physical locations. Also known as Ladder or Line diagram. See **Page 2**.

Separate Control: There is a different voltage source supplying the control circuit from that of the power/motor circuit. See **Page 4**.

Series Circuit: an electrical circuit that has only one path for the flow of the electricity. May have several pilot devices through which the electricity must flow before the circuit is completed.

Starter: A device to repeatedly establish or interrupt an electric power circuit to a motor, that also provides thermal protection to the motor. The two main components are a Contactor and an Overload Relay.

Three-Wire Control: See Low Voltage Protection (LVP), **Page 6**.

Two-Wire Control: See Low Voltage Release (LVR), **Page 6**.

Wiring Diagram: Shows all the devices in a circuit and their physical relationship to each other. Terminal connections for all components are identified to wire a complete circuit. See **Page 2**.

Eaton Corporation
Electrical Group
1000 Cherrington Parkway
Moon Township, PA 15108
United States
877-ETN CARE (877-386-2273)
Eaton.com



Cutler-Hammer

© 2007 Eaton Corporation
All Rights Reserved
Printed in USA
Publication No. TD03309004E/CPG
April 2007