



Before, During and After Hip and Knee Replacement Surgery

A PATIENT'S GUIDE



Acknowledgments

This revised booklet is based on information produced over the years by a variety of organizations. We would like to acknowledge the contributions made by:



The Arthritis Society, BC & Yukon Division



The Mary Pack Arthritis Program



Hip Hip Hooray



BC Orthopedic Association



Canadian Orthopedic Foundation

This edition of the booklet was developed by OASIS (OsteoArthritis Service Integration System) at Vancouver Coastal Health in partnership with staff at:



Vancouver Island Health Authority



Northern Health Authority



Interior Health Authority



Fraser Health Authority



Providence Health Care

We would also like to thank the joint replacement clients who participated in the revision process of this booklet. Your feedback and suggestions will be of great help to people who are preparing for joint replacement surgery.

Contents

Hip Surgery

- Hip Anatomy 7
- Hip Replacement Surgery..... 8
- Joint Components and Attachment 9
- Hip Precautions..... 10

Knee Surgery

- Knee Anatomy 15
- Knee Replacement Surgery..... 16
- Joint Components and Attachment ... 16
- Knee Precautions..... 18

Before Surgery

- Home Set-Up 23
- Exercise 28
- Nutrition 29
- Weight Management 30
- Pre-Operative Education 31
- Pre-Admission Clinic 31
- Final Checklist Before Surgery..... 32

During Your Hospital Stay

- Day of surgery 35
- Length of stay..... 37
- Rehabilitation 38
- Pain Control..... 39
- Preventing Blood Clots..... 41
- Going Home 41

After Surgery

- Recovery At Home..... 45
- Returning to Work..... 53
- Complications 54

Resources..... 61

Index 62

You are about to have hip or knee replacement surgery. Patients who are prepared for surgery and who take part in their care can recover in less time and with less pain. This booklet will give you the general information you need to get yourself, your family and your home ready for surgery. Read this booklet with care and bring it to the hospital when you go for surgery. We hope that you find this booklet a useful reference guide before, during and after your joint replacement surgery.

***IMPORTANT: If your surgeon or health care team gives you different advice than what has been provided in this booklet, please follow the specific directions you receive.**

Do you still have questions about joint replacement surgery?
Would you like to talk to someone who has gone through the surgery?

If so, **Ortho Connect** is for you! It is a program through the Canadian Orthopedic Foundation that will connect you with a volunteer who has gone through a similar surgical treatment. You will be able to ask the volunteer questions about what to expect through this experience and get useful tips on how to cope.

More information is available at:

www.canorth.org (click on “patient resources”)

or phone **1-800-461-3639**

or email mailbox@canorth.org



Hip Surgery

In this section, you will learn about:

- ➔ Hip Anatomy
- ➔ Hip Disease
- ➔ Total Hip Replacement Surgery
- ➔ Hip Resurfacing Surgery
- ➔ Hip Revision Surgery
- ➔ Artificial Joint Components
- ➔ Joint Attachment (Fixation)
- ➔ HIP PRECAUTIONS

Hip Anatomy

The hip joint is a ball and socket joint – that’s why you can move your hip in many directions. The ball is the round head of the thigh bone (femur). It moves in the socket of your pelvis (acetabulum). Muscles and ligaments support and strengthen the joint.

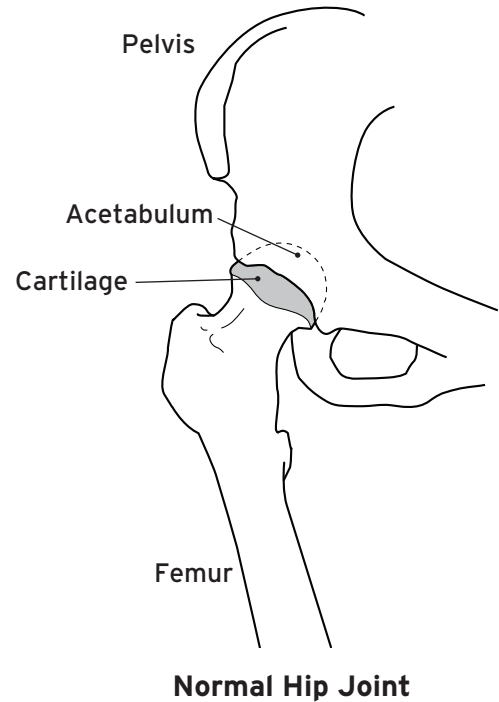

Hip Disease

The most common reason for joint replacement surgery is **OSTEOARTHRITIS**. Osteoarthritis results in the breakdown of cartilage on the ends of the bones. It usually appears in joints that carry your body weight, such as hips and knees. Osteoarthritis can cause joint pain and stiffness. Advanced joint damage can be repaired through joint replacement surgery.

Other disease conditions may also lead to damage of the joint, requiring joint replacement surgery. These include conditions such as rheumatoid arthritis, bone infection or a lack of blood supply to the bone. Talk to your doctor if you have questions about your joint health.

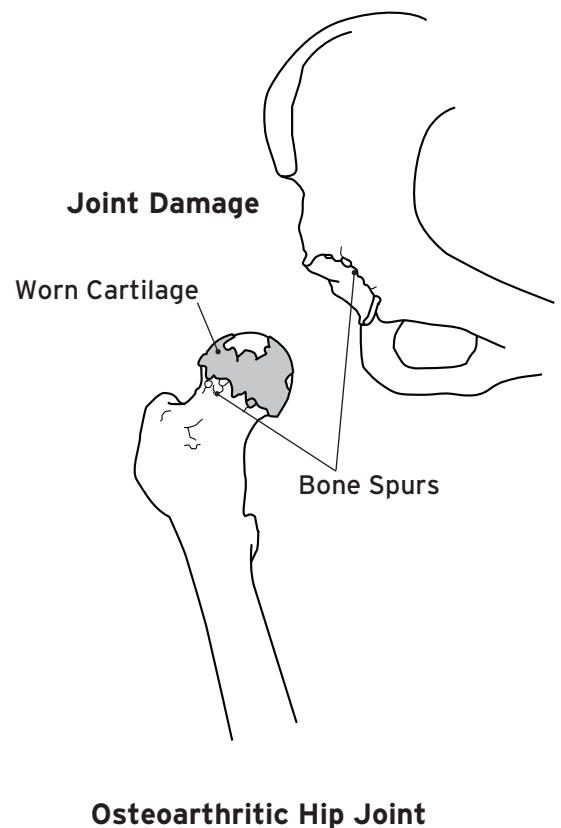

Total Hip Replacement

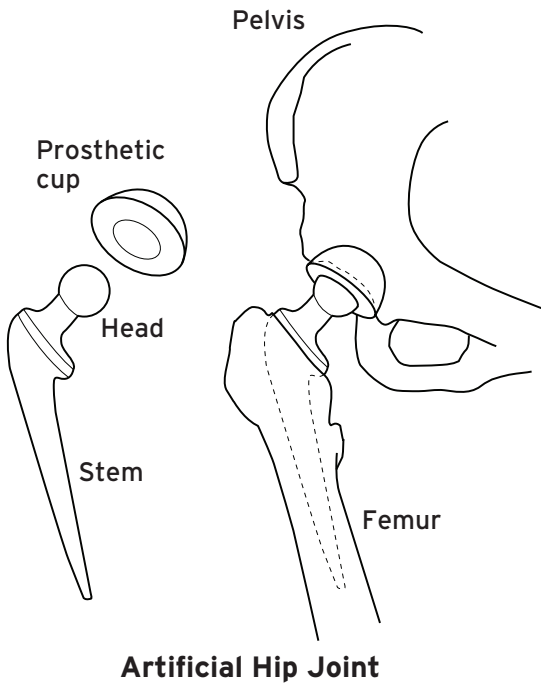

In total hip replacement surgery, the surgeon replaces the diseased joint with an artificial joint (prosthesis). First, the surgeon makes an incision and moves the muscles and ligaments away from the hip joint. Then the head of the thigh bone is replaced with an artificial ball and stem. The pelvic socket is smoothed and lined with a prosthetic cup. Then the joint is put back together with the ball fitted into the cup. Once the new joint is in place, the muscles and ligaments are repaired. Your skin is closed with sutures or staples (staples are metal clips that hold your skin together while the incision heals). This surgery takes about two hours.

Today, many patients who have hip replacement surgery can move their joint more easily, have less pain and are able to walk more comfortably for up to 25 years after surgery.

Hip Resurfacing

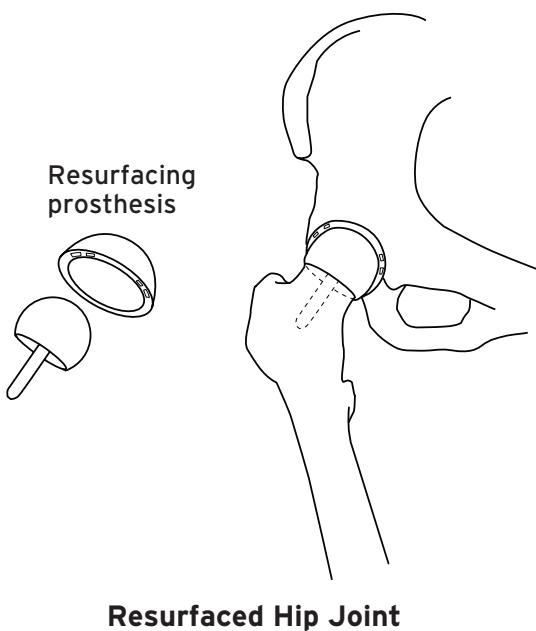

Hip resurfacing is a type of hip replacement surgery that may be suggested by your surgeon based on a number of factors including the degree of damage to your joint and your overall health.

In this surgery, the surgeon replaces the diseased joint with a special form of artificial joint (resurfacing prosthesis). First, the surgeon makes an incision and moves the muscles and ligaments away from the hip joint. Then the damaged cartilage and some parts of the bone surface are removed from the head of the thigh bone (femur) and the hip socket (acetabulum). A ball-shaped cap is placed over the head of the thigh bone. The hip socket is smoothed and lined with a molded shell. Once the joint is put back together, the muscles and ligaments are repaired. Your skin is closed with sutures or staples (staples are metal clips that hold your skin together while the incision heals).

Hip Revision (Repeat)

Some people who have had a hip replacement may need another surgery because:

- The joint has dislocated
- The joint is loose or worn out
- There has been bone loss or an infection in the joint

These surgeries can be more complex and you may need more rehabilitation after surgery. You may not be able to carry as much weight on your new joint while you recover.

Joint Components (Prosthetics)

Artificial joint components may be made of medical-grade metal, plastic, ceramic or some combination of these materials. Your surgeon will determine the type of joint to be used, matching your individual needs with a suitable type of material.

Joint Attachment (Fixation)

The type of fixation used to secure the artificial joint in your body will depend on a variety of factors including your age, disease type and bone quality.

CEMENTED: The artificial joint pieces are secured to the bone with a quick-hardening adhesive.

CEMENTLESS: The artificial joint pieces are closely fitted into the bones. These pieces are covered in a rough material that encourages bone growth. Bone growth into the artificial joint can provide additional long-term joint stability. Some parts of the artificial joint may be screwed in place to keep the joint stable.

HYBRID: In this type of surgery, one piece of the artificial joint is attached with cement while the other piece is covered in a rough material that encourages bone growth. Bone growth into the artificial joint can provide additional long-term joint stability. Some parts of the artificial joint may be screwed in place to keep the joint stable.

Hip Precautions

After Hip Surgery, you will need to follow **HIP PRECAUTIONS for 3 MONTHS unless otherwise advised by your surgeon.** These activity restrictions will help your joint to heal and reduce the risk of hip dislocation. See “Complications” section for more information, [page 54](#).

Shaded leg is the surgical leg.

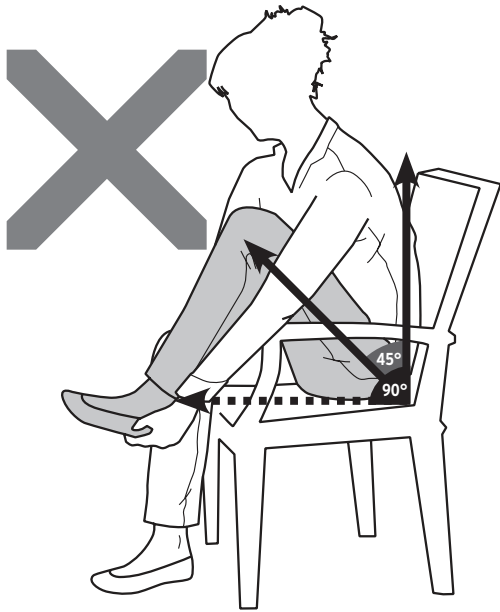

DO NOT bend your hip past 90 degrees

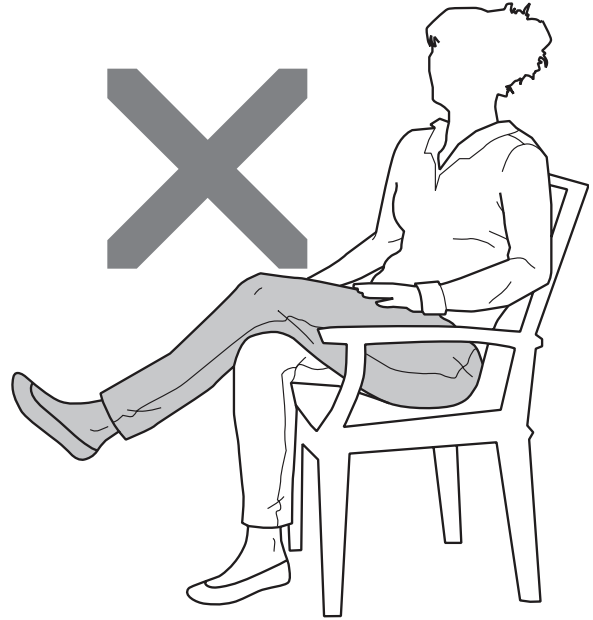

DO NOT cross your legs at the ankles or knees

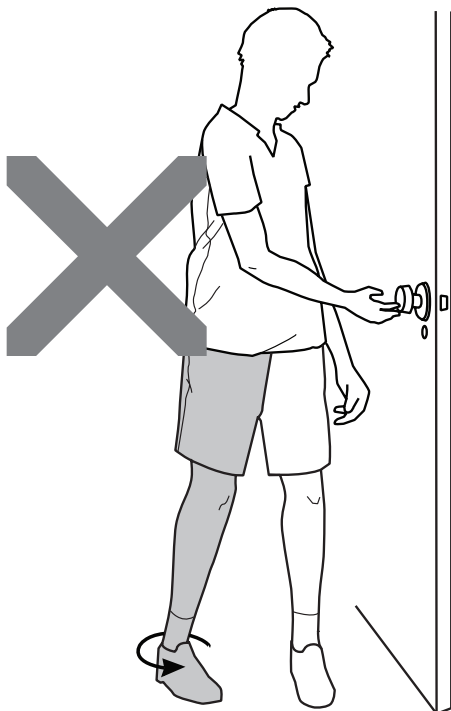

DO NOT twist your body or legs

Additional Notes for Hip Surgery and Precautions:

Things you CAN DO after hip surgery:

DO sit on a raised chair or use a high-density foam cushion to increase surface heights. Use a raised toilet seat. (see [page 49](#) for how to sit)

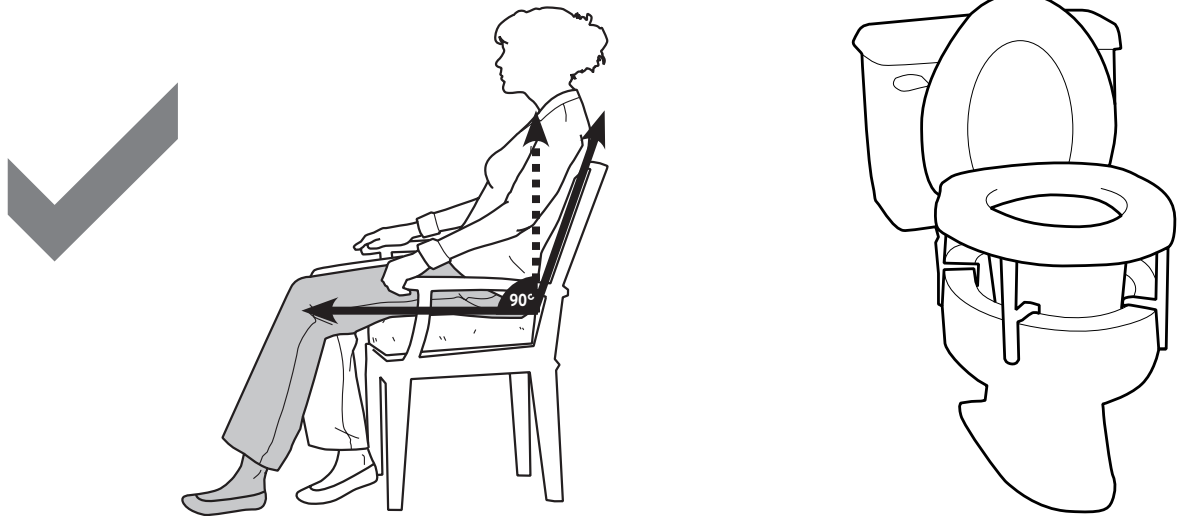

DO use long-handled aids, such as a shoehorn and reacher, to help you dress and pick up items.

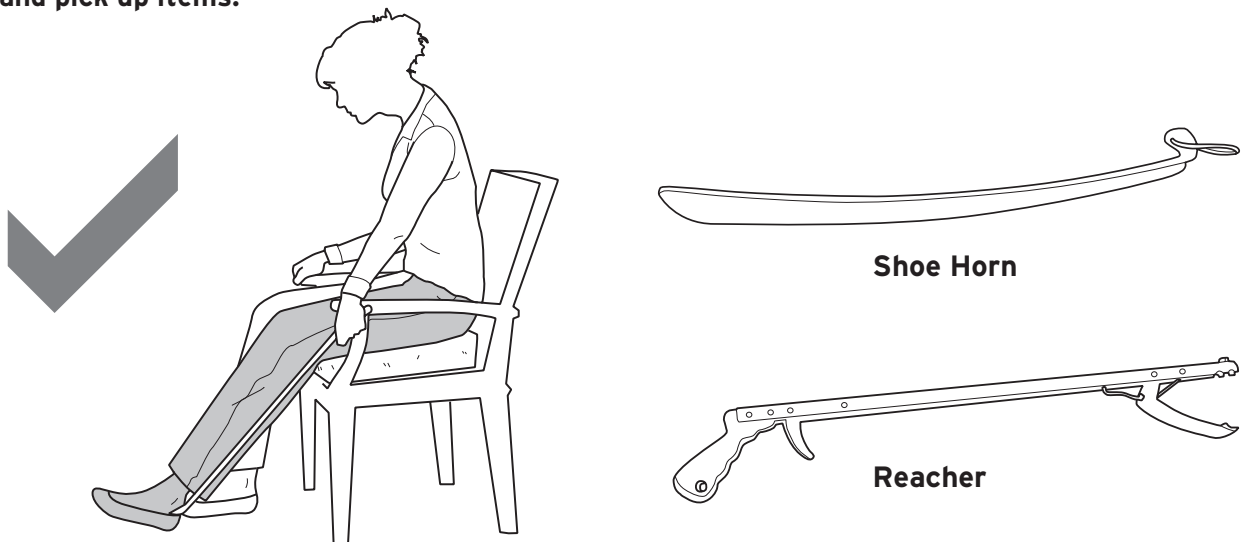

DO sleep with pillows between your legs for the first 3 months after surgery. You may require assistance placing the pillows or choose to use an extra-long pillow.

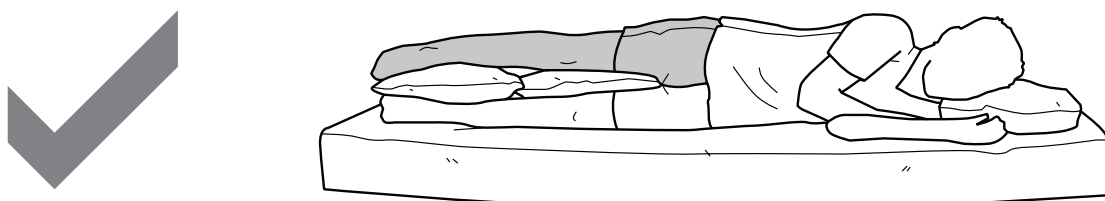

Knee Surgery

In this section, you will learn about:

- ➔ Knee Anatomy
- ➔ Knee Disease
- ➔ Total Knee Replacement Surgery
- ➔ Bilateral Knee Replacement Surgery
- ➔ Unicompartamental Knee Replacement Surgery
- ➔ Artificial Joint Components
- ➔ Joint Attachment (Fixation)
- ➔ KNEE PRECAUTIONS

Knee Anatomy

The knee joint is where the thigh bone (femur) meets the shin bone (tibia). The knee is a hinge joint that allows you to bend and straighten your leg.

Knee Disease

The most common reason for joint replacement surgery is **OSTEOARTHRITIS**. Osteoarthritis results in the breakdown of cartilage on the ends of the bones. It usually appears in the joints that carry your body weight, such as hips and knees. Osteoarthritis can cause joint pain and stiffness that may require joint replacement surgery.

Other disease conditions may also damage the joint, requiring joint replacement surgery. These include rheumatoid arthritis or an injury to the joint. Talk to your doctor if you have questions about your joint health.

Total Knee Replacement

In total knee replacement surgery, the surgeon replaces the diseased joint with an artificial joint (prosthesis). First, the surgeon makes an incision and moves the muscles and ligaments away from the knee joint. Then the damaged bones are reshaped to fit the artificial joint. The ends of the thigh bone and shin bone are covered with metal shells, separated by a plastic liner. If the kneecap (patella) is damaged, it may be lined with a plastic disc. Once the new joint is in place, the muscles and ligaments are repaired. Your skin is closed with sutures or staples (staples are metal clips that hold your skin together while the incision heals). This surgery takes about two hours.

Today, many patients who have knee replacement surgery can move their joint better, have less pain and are able to walk more comfortably for up to 25 years after surgery.

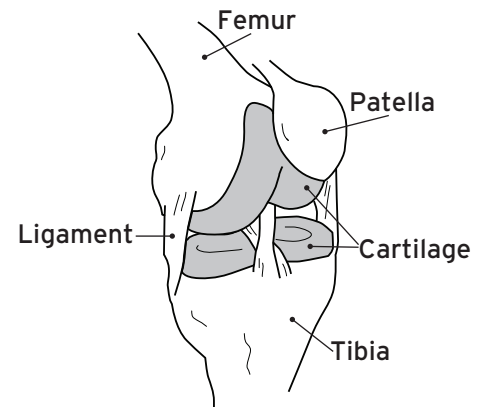

Normal Knee Joint

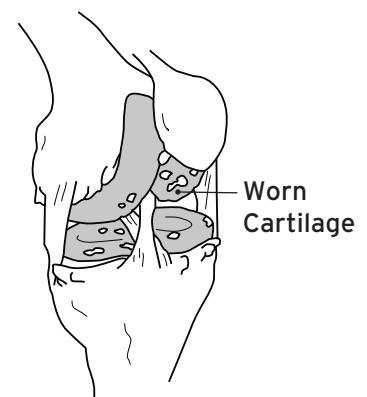

Osteoarthritic Knee Joint

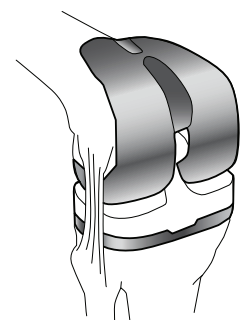
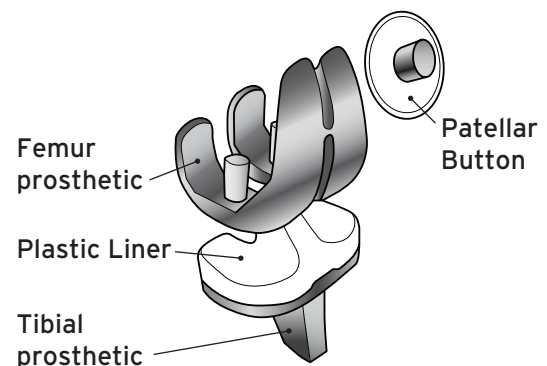

Artificial Knee Joint

Bilateral (Both) Knee Replacement

In some cases, a surgeon may decide that both knees need to be replaced at the same time. This depends on a number of factors including your overall health, joint damage and lifestyle. The surgery will be the same as a total knee replacement. Your hospital stay may be longer and you may need more rehabilitation after surgery to help you get back to your daily activities.

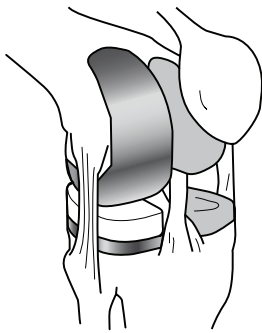

Partial Knee Joint

Unicompartmental (Partial) Knee Replacement

If you only have bone damage on one side of your knee, your surgeon may decide that you are a suitable candidate for partial knee replacement surgery. As with total knee replacement surgery, the surgeon reshapes the damaged parts of the bone to fit the artificial joint (prosthesis). Many people who have this kind of joint replacement surgery recover more quickly than people who have total knee replacement surgery. People who have partial knee replacement surgery are often sent home from the hospital the day after surgery.

Knee Revision (Repeat)

Some people who have had a knee replacement need another surgery. This can be because:

- Your new joint is loose or worn out
- You had bone loss or an infection in the joint

These surgeries can be more complex and you may need more rehabilitation. Compared to your first surgery, you may not be able to carry as much weight on your new joint while you recover.

Joint Components (Prosthetics)

Artificial knee joint components are made of medical-grade metal and plastic. There can be differences in the anatomy of men's knees and women's knees. Your surgeon may choose a "gender-specific" knee joint for you, depending on the shape of your knee.

Joint Attachment (Fixation)

The artificial joint can be secured in different ways:

CEMENTED: The artificial joint pieces are secured to the bone with a quick-hardening adhesive material.

CEMENTLESS: The artificial joint pieces are closely fitted into the bones. These pieces are covered in a rough material that encourages bone growth. Bone growth into the artificial joint can provide additional long-term joint stability. Some parts of the artificial joint may be screwed in place to keep the joint stable.

HYBRID: A combination of these methods.

Knee Precautions

After Knee Surgery, you will need to follow Knee precautions for 3 months or until advised by your surgeon. These activity restrictions will help your joint to heal and reduce stiffness in the new joint. See “Complications” section for more information, [page 54](#). *Shaded leg is the surgical leg.*

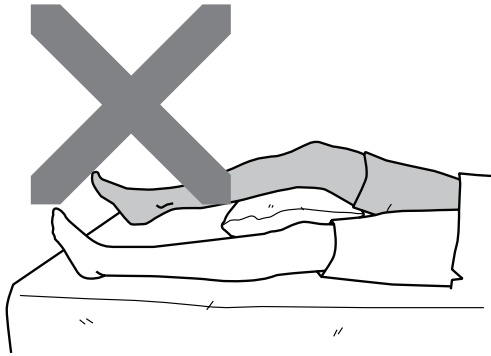

DO NOT put a pillow behind your knee. Your knee may become stiff if you keep it bent.

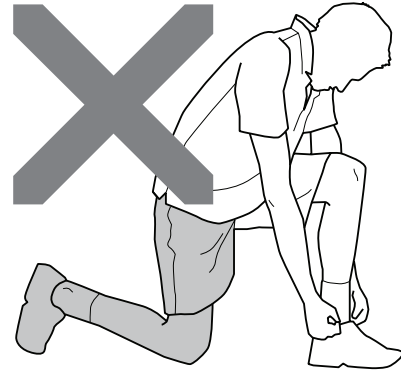

DO NOT kneel on your new knee joint

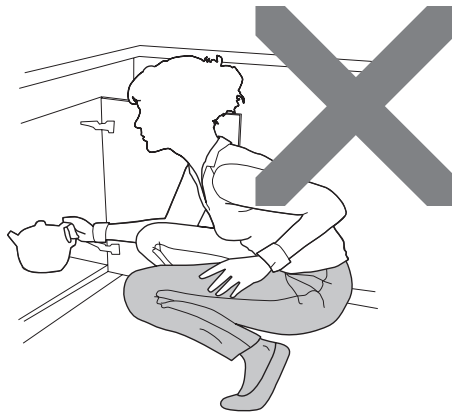

DO NOT do deep squats (squatting down to the floor.)

Additional Notes for Knee Surgery and Precautions:

Things that you CAN DO after knee surgery:

DO sit on a raised chair or use a cushion. It will be easier to get on and off higher surfaces after surgery. Consider using a raised toilet seat.

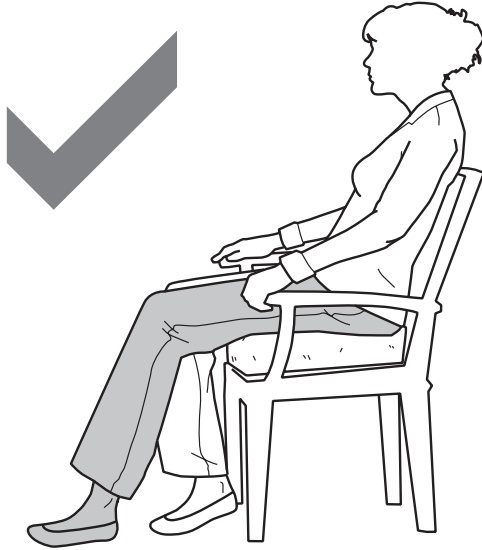

DO use long-handled aids, like a shoehorn and reacher, to help you get dressed or pick up items.

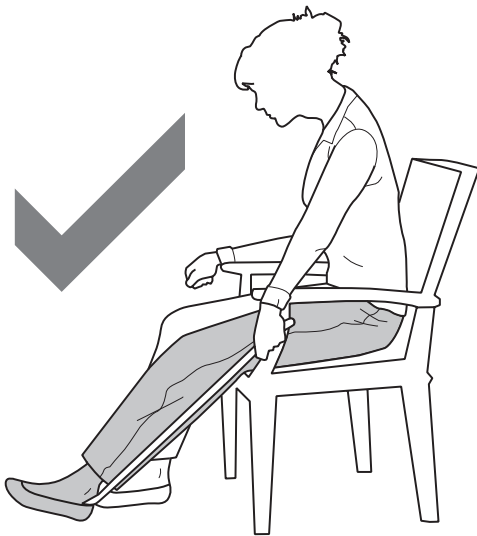

Shoehorn

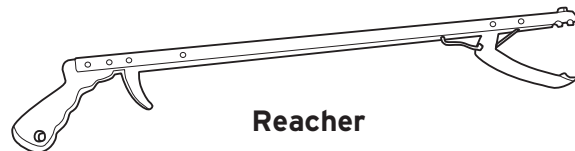

Reacher

Before Surgery

In this section, you will learn about:

- ➔ Home Set-up
- ➔ Equipment
- ➔ Exercise
- ➔ Nutrition
- ➔ Weight Management
- ➔ Pre-op Education
- ➔ Pre-Admission Clinic
- ➔ Final Checklist for Hospital

Home Set-Up

It is important to set up your home BEFORE joint surgery. This will allow you to easily move around your home with a walker or crutches after surgery, reduce the risk of falls and maintain your hip or knee joint precautions.

- Ensure hallways and rooms are free of clutter and tripping hazards (eg scatter rugs, footstools, etc.)
- Add non-slip surfaces to outside stairs and walkways
- Install stair railings or make sure the existing ones are secure
- Set up a firm chair with armrests. If you have had hip surgery, see [page 25](#) for more information on seating heights.
- Ensure good lighting in hallways and other well used areas
- Arrange for extra help with household tasks if needed (i.e. vacuuming, laundry)
- Move frequently used household items to counter height (i.e. pots and pans). Consider moving items in the lower parts of the fridge/freezer to a higher shelf.
- Stock your freezer/pantry with healthy foods and snacks. If needed, private food/meal delivery services are available in many areas.
- Keep an ice pack in your freezer for possible joint swelling after surgery. Alternatively, you can use a bag of frozen peas.
- Have a thermometer at home to check your temperature if needed after surgery.

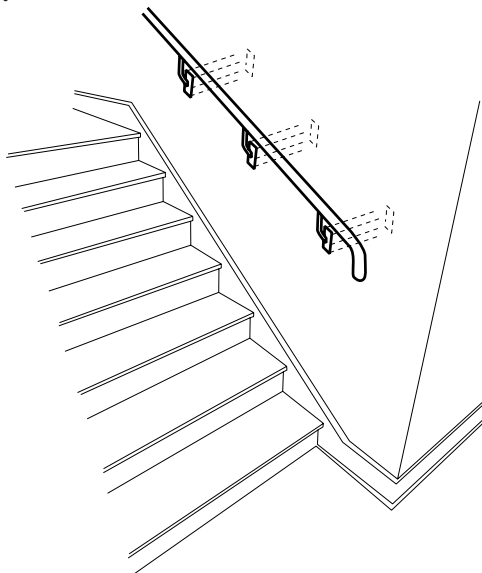

Secure Stair Rails

Bathroom

- Install a raised toilet seat with armrests / toilet safety frame to assist you to sit or stand
- Remove sliding doors from your bathtub and replace with a shower curtain
- Set up a tub transfer bench (in the bathtub) or a shower chair (in a shower stall)
- Use a non-slip bathmat both inside and outside the bathtub or shower
- Install a hand-held shower hose in the bathtub
- Grab bars in the bathtub/shower stall and by the toilet are very useful. Removable grab bars are available. Do NOT use towels racks or toilet paper holders to assist you to stand or sit.



Raised Toilet Seat

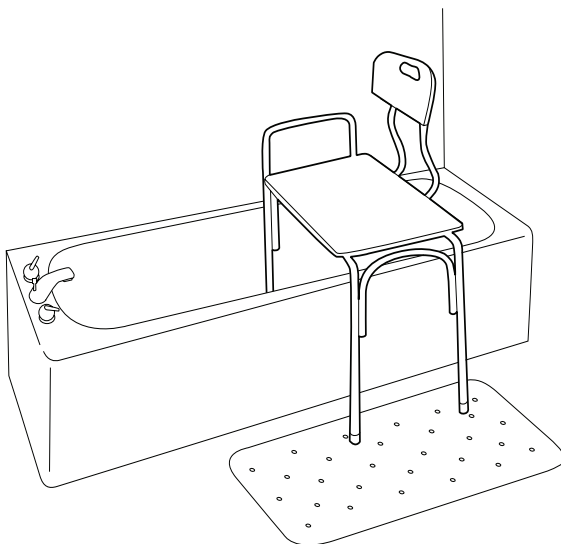

Tub Transfer Bench

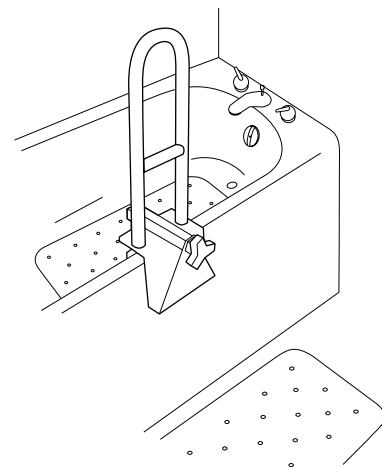

Removable Tub Clamp

Seating After HIP SURGERY:

- As you are not able to bend your hip past 90 degrees for 3 months after hip surgery, ALL surfaces that you sit on MUST be 2 inches above knee height. This includes chairs, beds and toilets.

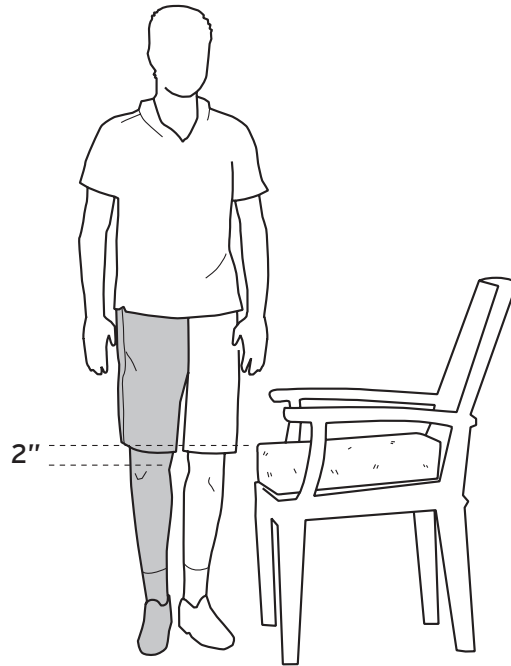

- Use a high-density foam cushion or bed blocks to increase chair height. Plan to take your foam cushion with you to adapt chairs outside of the house.
- Set up a firm chair with armrests (not a rocking chair).
- Set up a table beside your chair for frequently used items as you will not be able to bend forward to the coffee table.
- If your bed is too low, add another mattress or place the frame on bed blocks.

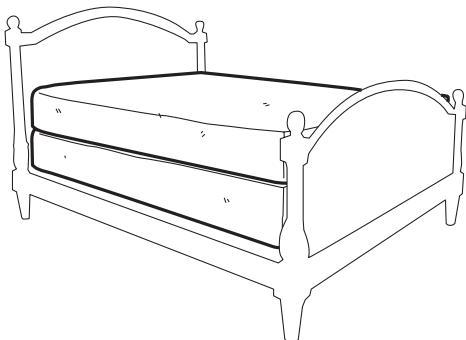

Extra mattress

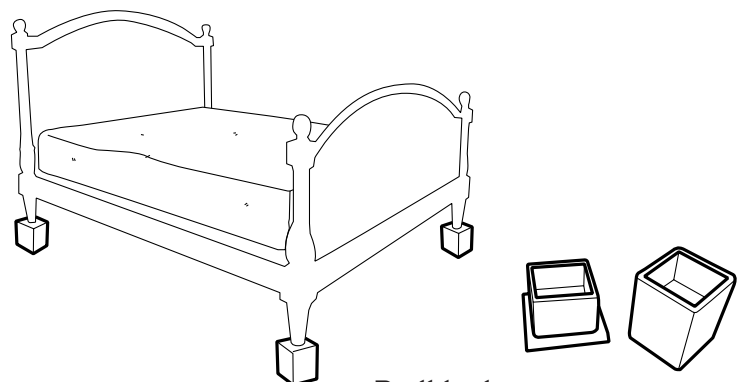

Bedblocks

Equipment List - Arrange up to 2 weeks before surgery.

Equipment you MUST bring to HOSPITAL - unless otherwise told

Hip Surgery

- Walker
 - Standard OR 2-wheeled
- Crutches
- High density (firm) foam cushion* (at least 4 inch x 16 inch x 18 inch, needed for going home in the car)
- Dressing equipment (long handled reacher, long handled shoe horn and sock aid)

Knee Surgery

- Walker
 - Standard OR 2-wheeled
- Crutches
- Dressing equipment (long handled reacher, long handled shoe horn and sock aid) –
OPTIONAL but recommended

Equipment for HOME

Hip Surgery

The equipment below is **required**

- 4 inch raised toilet seat (with or without armrests)
OR commode chair with wheels
- 26 inch Long handled reacher
- 24 inch Long handled shoehorn
- Sock aid
- 24 inch long handled sponge*
- Non-slip bathmat*
- Elastic shoe laces* (otherwise use slip on shoes with an enclosed heel)
- Hand-held shower hose*

Bathing – use a **walk-in shower:** OR **bathtub:**

Shower chair

Tub transfer bench OR

Raised shower board

Removable tub clamp

OR installed grab bars*

**Items NOT available at the Red Cross may be purchased at local medical supply stores.*

Where to Get Equipment

Red Cross Loan Cupboards

- Locations throughout BC
- Provides “free” equipment for 3 months (donations gratefully accepted)
- **REQUIRES a signed equipment request form.** This form will be provided by the hospital, at your pre-operative education class or through your community therapist. If you do not have this form less than 1 week before surgery, please contact your local hospital.
- Be aware that The Red Cross has a limited supply of equipment and may not have all the items you need.

Medical Supply Store

- Equipment for rent and/or purchase
- May deliver to your home and/or install
- Costs may be covered by extended health plans – check your plan

Government Agencies

- Veterans Affairs Canada (VAC)

Friends/Family

Check with friends and family who may have equipment you can borrow

** Please ensure that equipment fits in your home and is in good working order before you have your surgery*

Transportation Support

Some transportation support services require application forms to be completed by you and your doctor or health professional. These services include temporary disabled parking passes (SPARC pass) and HandyDart.

For more information on the services listed above, see the Resources section of this booklet, [page 61](#).

Exercise

Exercising before surgery will help you have a faster and easier recovery. Do activities that put less stress on your joint. Try:

- exercises in water, such as swimming or water walking at a community pool
- cycling
- Nordic pole walking
- gentle stretching and strengthening
- specific exercises suggested by a physiotherapist
- balance exercises (valuable in preventing falls)

These activities will make your muscles strong, improve your endurance and help keep your joint moving. Exercising before surgery will also help you to build up your confidence and knowledge of how to exercise after surgery.

****REMEMBER:** After surgery, daily exercise will be part of your rehabilitation for many months.*

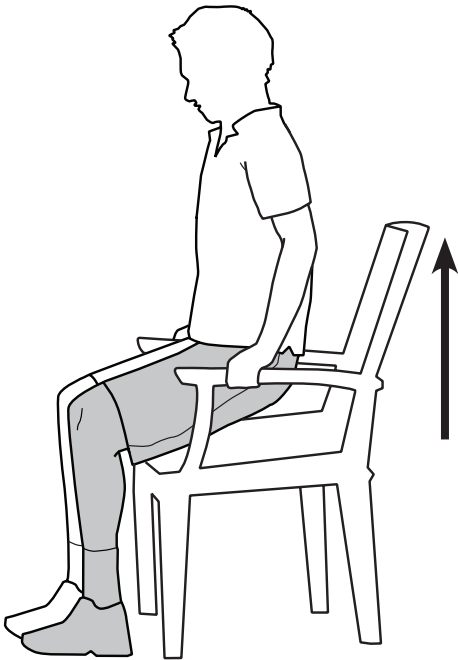

Be sure to strengthen your arm muscles. You will need strong arms after your surgery to use walking aids, get in and out of bed and get on and off a chair. If possible, do strengthening exercises for at least 3 weeks before surgery.

For example: Push up through your arms while seated. Work up to 10 repetitions 2 times each day.

If this exercise causes you discomfort or if you are new to exercise and/or have other health conditions, **always talk to your family doctor before starting a new exercise program.** If you don't know how to get started, talk to a physiotherapist.

Nutrition

Good nutrition helps you to recover from surgery and reduces the risk of infection. Important nutrients before and after surgery include:

Protein

Protein promotes healing after surgery. To meet increased protein needs, try to eat at least 3 servings from each of these food groups every day. For example:

<p>Meat and Alternatives</p> <p>1 serving =</p> <ul style="list-style-type: none">▶ 2-3 oz of meat, poultry or fish▶ 2 eggs▶ 3/4 cup beans▶ 3/4 cup tofu▶ 2 tablespoons peanut butter	<p>Milk and Alternatives</p> <p>1 serving =</p> <ul style="list-style-type: none">▶ 1 cup milk or soy beverage▶ 2 ounces cheese▶ 3/4 cup yogurt
---	---

Multivitamin

While a basic multivitamin is recommended to promote healing, large doses of any nutrient are generally not recommended. If you have a history of anemia, talk to your doctor, pharmacist or dietitian about supplements.

Calcium and Vitamin D

Calcium and Vitamin D are important for strong bones. Adults should have 2 to 3 servings of milk or calcium-fortified products a day. A minimum of 600IU Vitamin D supplement is recommended for all people over 50 years old. Talk to your doctor, pharmacist or dietitian about current supplement recommendations that are right for you.

Fibre and Water

It's important to have a regular bowel habit before joint surgery because constipation can be a complication. Include fibre in your diet, such as whole grains, bran, fruits and vegetables, beans and lentils. Spread the fibre throughout the day and drink at least 8 glasses of water or other low-calorie fluid a day.

For more information about nutrition, see Canada's Food Guide:

www.healthcanada.gc.ca/foodguide

Weight Management

Being **overweight** or **underweight** can affect your recovery from surgery. If you are **overweight**, moderate weight loss is a good strategy to reduce hip and/or knee pain and to allow you to do more activities. Every extra pound you carry places 3-6 pounds of force on your knees and hips. If you are trying to lose weight before surgery, aim for a gradual loss of no more than 1 pound per week. Avoid fad diets as they may cause you to be undernourished and prolong recovery.

approximately
1 EXTRA POUND = 3-6 POUNDS OF FORCE
on your knees and hips

Being **underweight** can make it harder for your body to heal after surgery. It is important to eat well before surgery.

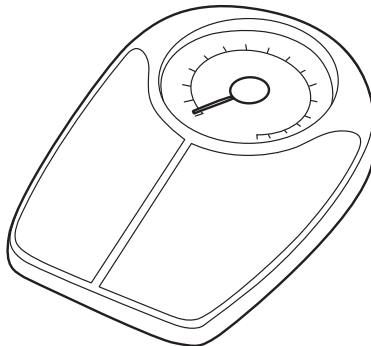

Talk to a dietitian if you are worried about being overweight or underweight before surgery. To find out more information on nutrition or specific nutrients:

HealthLink BC: **Call 811 to speak to a dietitian**

Website: www.healthlinkbc.ca

Dietitians of Canada Website: www.dietitians.ca

Pre-Operative Education

WHEN? As far in advance as possible*

The hospital will call to register you for a Pre-op Joint Replacement Class. At this session, you will learn more about your surgery, what to expect while you are in hospital and what you need to prepare at home. It is a good idea to bring a family member or support person with you to this session. For more information on preparing for surgery, see Resources on [page 61](#). ***In some BC hospitals, your pre-op education may be provided at your Pre-Admission Clinic visit.**

Pre-Admission Clinic (PAC)

WHEN? A few days before your surgery

The Pre-Admission Clinic will call you to schedule an appointment. This appointment may last a few hours. The nurse will discuss many points including:

- when to stop eating and drinking before surgery
- medicine management before and after surgery. **Some medicines and supplements must be stopped 1-2 weeks before surgery** to avoid problems with bleeding or sleepiness. Talk to your surgeon if you have questions about your medicines.
- allergies

Bring ALL of your medicines/supplements to your Pre-Admission Clinic appointment.

You may have some tests done including:

- Blood work
- X-ray
- ECG (electrocardiogram)

You may also be scheduled to meet with an anesthesiologist. This is a medical doctor who is trained to give anesthetic drugs and monitor you throughout your surgery. *Bring any questions about your anesthesia to your Pre-Admission Clinic appointment.*

Your surgery may be cancelled if you have: an active infection anywhere in your body, a skin infection over the joint, a cold or the flu. If you are sick before surgery, *call your surgeon.*

1 Day Before Surgery: A FINAL Checklist

By now you should have picked up your medical equipment and set up your home. Here is a final checklist of things you need to do before coming to the hospital:

- Label all of your equipment with your name (walker, crutches, dressing equipment) – if you are bringing these items to the hospital
- Make arrangements for transportation to and from the hospital
- Make arrangements for someone to stay with you or be near by for at least the first 72 hours after you leave the hospital
- Have a bath or shower using regular soap the night before, or the morning of your surgery (**do not** shave your legs as any cuts or skin irritation may result in your surgery being cancelled)
- Pack your bag for the hospital. Bring:
 - toiletry items (toothbrush, hair brush etc.)
 - loose fitting clothes to exercise in and to wear home
 - comfortable, closed toe and heel shoes/slippers with non-slip soles. Your shoes should be roomy since you will have some swelling in your feet.
 - if you wear elastic support stockings, bring them with you
 - eye glasses and reading materials
 - hearing aids
 - if needed, credit card information for items such as hospital TV rental

DO NOT bring valuables to the hospital

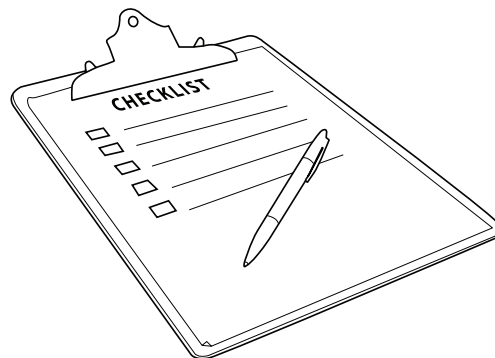

During Your Hospital Stay

In this section, you will learn about:

- ➔ Day of Surgery
- ➔ Recovery Room
- ➔ Length of Hospital Stay
- ➔ Rehabilitation
- ➔ Pain Control
- ➔ Heparin Injections
- ➔ Going Home

Day of Surgery

Before Surgery:

- Go to the Admitting Desk in the hospital
- Bring all of your medicines with you, as directed by the Pre-Admission Clinic
- Ask friends or family to bring your labelled equipment to the hospital ward unless otherwise instructed
- To prepare for surgery, you will change into a hospital gown and a nurse will start an intravenous line (IV) in your arm

During Surgery: Anesthesia

Each hospital manages your anesthetic differently. Many people who have joint replacement surgery have a **spinal anesthetic**. This is like the freezing you get at the dentist, except this freezing goes into your back and makes you numb from the chest down and stops you from feeling pain. The anesthesiologist will make sure you are comfortable throughout the surgery, giving you medicine through your IV that makes you relaxed and sleepy. If you have a spinal anesthetic, you will not be able to move your legs for up to 4 hours after surgery.

Some people receive **general anesthetic**. This is a combination of drugs that will make you unconscious during the surgery.

Bring any questions you have about anesthetic to your Pre-Admission Clinic appointment.

After Surgery: Recovery Room

- You are moved from the operating room to the recovery room
- You may have oxygen by mask for a short time or nasal oxygen overnight
- The nurse monitors your vital signs, including your pulse and blood pressure
- You will have pain medicine on a regular basis. **Tell your nurse if you are in pain.**
- Some people may have compression devices placed on their lower legs. Compression devices gently squeeze your calf muscle to help with blood circulation.
- The stay in the Recovery Room is usually 1 to 3 hours

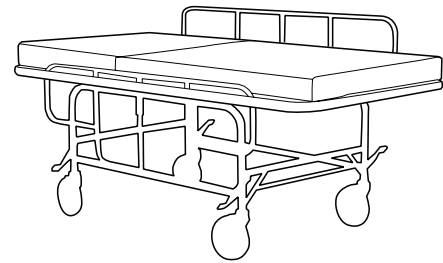

After Surgery: The Hospital Ward

- Once you are medically stable, you are transferred to the orthopaedic ward
- You will be told how much weight you can put on your new joint (weight bearing status). This can vary for each individual. Often people are told to weight bear as tolerated, but you may have a weight-bearing restriction such as partial, feather, or non-weight bearing on your surgical leg
- The ward staff helps you to stand on your new joint if allowed by your surgeon
- The nurse assesses you for pain and nausea
- You will use a commode/raised toilet seat during the day and a bedpan/urinal at night. When you are able, you will walk to the bathroom. Some people who have spinal anesthetic find it difficult to urinate and will need a catheter (a temporary tube placed in your bladder to empty it).
- You may have blood work
- You may have an intravenous line (IV) for medicine
- After knee surgery, you may have a drain on your leg to collect blood from your knee
- You are taught exercises to help reduce complications after surgery, such as:
 - breathing deeply and coughing every hour to keep your lungs clear
 - pumping your ankles to improve circulation in your legs

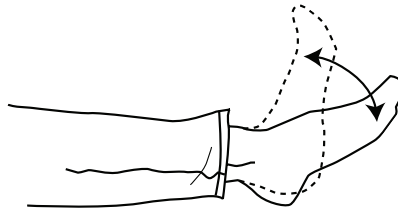

- Most people will be started on a medicine that helps reduce the risk of developing a blood clot after surgery. See “Preventing Blood Clots” for more information, [page 41](#).

Length of Hospital Stay Guidelines

Your time in the hospital is **short**. Your healthcare team will work with you to make sure you are medically stable and able to manage daily tasks to go home. Before surgery, it is important to make arrangements to have someone pick you up from the hospital when going home. Discharge time is usually in the morning.

Be aware that you may go home sooner than expected.

Ensure your travel arrangements are flexible.

Total Hip Replacement = 3 nights or LESS

(includes resurfacing and revision surgery)

Total Knee Replacement = 3 nights or LESS

(includes revision surgery)

Partial Knee Replacement = overnight

Bilateral (both) Knee Replacement = 5 nights or LESS

For example: If you have surgery on Monday and are spending 3 nights in the hospital, you will probably be sent home on Thursday morning.

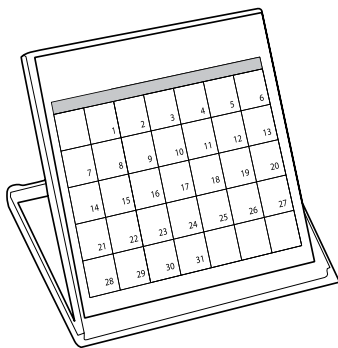

Monday SURGERY DAY

Tuesday

Wednesday

Thursday DISCHARGE HOME

Rehabilitation

- **Physical activity is a very important part of your recovery.** Not only does it help to improve the function of your joint, but it also helps clear your lungs, reduces the risk of blood clots in your legs, reduces pain, and starts your bowels moving.
- The physiotherapist (PT) will work with you throughout your stay. Your physiotherapist will teach you how to:
 - ▶ walk with a walker and/or crutches
 - ▶ do your daily exercises
 - ▶ use the stairs safely
- The physiotherapist will give you exercises to do in hospital and at home. They may also refer you to a physiotherapist in your local community.
- The occupational therapist (OT) will teach you how to do daily activities, such as dressing and bathing, while following precautions and protecting your new joint.

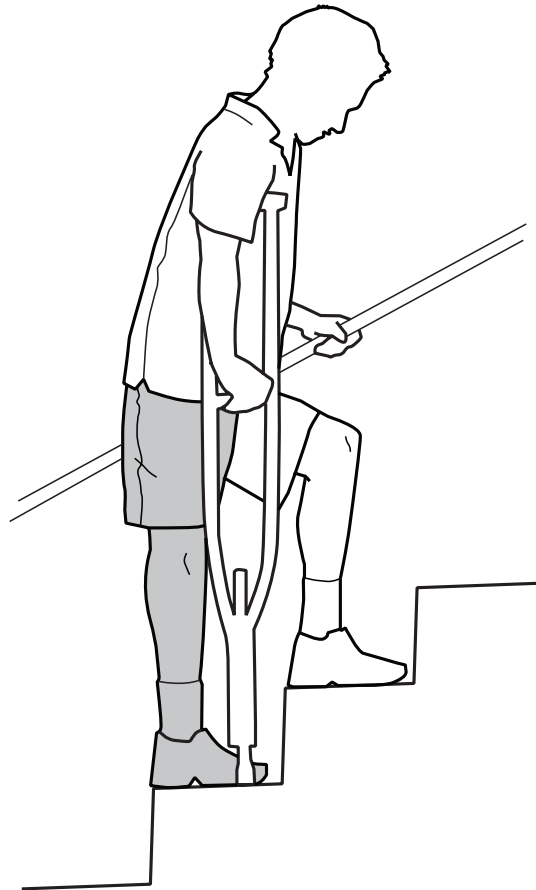

Pain Control

Pain Control After Surgery

- Your nurse will teach you how to use the pain scale to describe your level of pain. “0” is no pain and “10” is the worst possible pain.

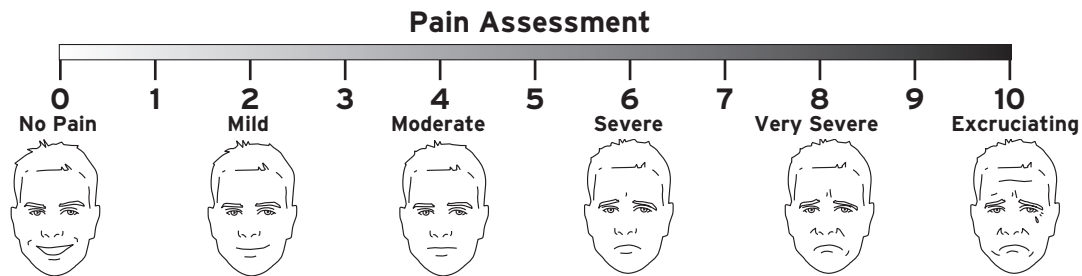

- **It is our goal to keep your pain at “3-4” or below at all times.**
- Generally, pain medicine is given as a pill taken by mouth.
- If you have had a general anaesthetic, you may have a patient controlled analgesia (PCA) pump. This is when a controlled amount of pain medication is pumped into your IV tube when you push a button.
- A combination of medicines will likely be used to control your pain after surgery. This normally would include acetaminophen (i.e. Tylenol™) plus possibly an anti-inflammatory (i.e. NSAID) and/or narcotic (i.e. morphine). By taking a combination of these medicines, you may be able to reduce the side effects of any one of these medicines and have improved pain control. It is important to talk to your healthcare team to understand how and when to take these medicines to best control your pain and symptoms.
- Some side effects of pain medicine can include: nausea, vomiting, drowsiness, itchiness and/or constipation. Tell your nurse if you have any of these symptoms.

Pain Control at Home

Most people have less and less pain over the next 6 to 12 weeks. If pain is preventing you from caring for yourself, sleeping and/or exercising, talk to your physiotherapist or doctor. **If your pain becomes increasingly worse or if you have pain in a new part of your body, seek medical attention immediately.** (See back cover of this booklet for guidelines).

Here are some ways to manage your pain:

- **Take pain medicine** as directed. It is normal to have some increased pain or symptoms during physical activity or physiotherapy sessions. It may be helpful to take a dose of pain medicine 1 or 2 hours before engaging in these activities in the first weeks after surgery. It is better to take medicine **BEFORE** the pain is severe.
- **Ice** can reduce pain and inflammation. It is particularly useful for people who have had knee replacement surgery. Place an ice pack wrapped in a towel on your joint as directed by your physiotherapist.
- **Pace yourself.** Do not push yourself. Regular rest is an important part of your healing process.
- **Relax.** Use relaxation techniques such as breathing exercises or progressive muscle relaxation (progressive muscle relaxation is when you tighten and relax each part of your body, starting with the toes and working up to your neck).
- **Distract** yourself. Listen to music, visit with friends, write letters, watch TV.
- **Think positively.** You will become more and more comfortable as you recover from your surgery.



Preventing Blood Clots

After hip or knee replacement surgery, you are at risk for developing a blood clot (see “Complications”, [page 55](#)). Many people are given a medicine after surgery to reduce this risk.

- The medicine may be a pill that you take once a day for a month after surgery, OR
- The medicine may be an injection that is taken once a day for 10-35 days after surgery
- Your surgeon will decide which medicine is right for you. Hospital staff will be available to answer any questions about the medicine and how to take it.
- Fill your prescription at a pharmacy near the hospital, in case your local pharmacy does not carry the medicine.
- It is important to take the medicine exactly as prescribed.

Going Home

For most people, you will be discharged to **your home**, not a rehab facility. Before leaving the hospital, plan appointments with the following people:

Follow-Up Medical Appointments

- The person (e.g. GP or physiotherapist) who will remove your staples, 7-14 days after surgery
- Your surgeon, usually around 6 weeks after surgery
- Your physiotherapist, usually within 1 week of discharge (if recommended by your surgeon)
- Your family doctor, once you are back on your feet, to review your general condition

After Surgery

In this section, you will learn about:

- ➔ Physiotherapy After Hospital
- ➔ Transportation
- ➔ Everyday Activities Guidelines
- ➔ Wound Care
- ➔ Sexual Activity
- ➔ Returning to Work
- ➔ Complications
- ➔ Dental Work or Other Medical Procedures

Recovery at Home

Physiotherapy After Hospital

The hospital physiotherapist will help you to arrange a physiotherapy appointment for when you get home from hospital. Depending on your needs, where you live and local services, your appointment may be at a physiotherapy clinic, out-patient hospital centre, rehab facility or home health program.

Your physiotherapist will give you exercises to stretch and strengthen your legs and improve your walking and balance. As you recover, the exercises will get harder. Doing the exercises assigned by your physiotherapist will help you move your new joint and enjoy greater independence. It is important to continue with the exercises for at least 1 year after your surgery.

Talk to your physiotherapist if you have questions about your exercises or concerns about your progress.

Transportation

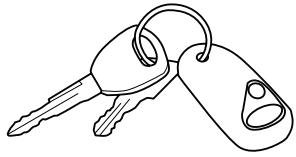

Personal vehicle

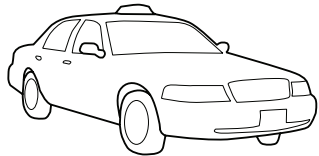

Taxi

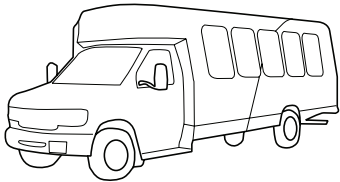

HandyDART

There are many different ways to get around after surgery. Here are some options:

- Friends / family
- Taxis
- Temporary disabled parking pass (SPARC)*
- HandyDART* (if available in your community) — transit service for those who cannot use the regular bus service. HandyDART will pick you up and drop you off at appointments such as medical visits.
- Travel Assistance Program (TAP)*— assists with costs for out-of-town medical travel

*Talk to your healthcare providers about completing the necessary forms for these services **BEFORE** surgery. See “Resources” [page 61](#).*

Air Travel

You may have some extra challenges travelling by plane after surgery. Be sure to give yourself extra time when flying. Your new joint may set off metal detectors at the airport. If you are flying within 3 months of having hip surgery, bring your high-density foam cushion to raise the height of your seat. While on the plane, do foot pumping exercises every hour to help reduce the risk of clots. If flying home from hospital, check with your air carrier if medical documentation is needed.

Driving

Driving is restricted after knee or hip surgery. There are a number of factors that can impact your ability to safely return to driving. These include using mobility aids and taking prescription pain medicines. Talk to your surgeon and physiotherapist before driving. Most people start to drive within 12 weeks after surgery.

Car Transfer

It can be challenging to protect your joint getting into some cars, particularly following hip surgery. Talk to your occupational therapist if you have questions about car travel. Please practice these instructions before you come to the hospital.

- Park away from the sidewalk or curb so you are not stepping down from the curb to the car. If you have a high truck or sport-utility vehicle, you may need to park near the curb so that you do not have to climb up to the seat.
- Move the seat as far back as possible
- Recline the seat
- Place your high-density foam cushion on the seat. If it is a wedge cushion, position the thick end at the back of the seat.
- Back up to the seat until you feel the back of the seat on your legs
- Extend your operated leg
- Hold onto the back of the seat and the car to stabilize yourself
- Lower yourself to the seat
- Slide back and lift your legs into the car. (If you have had hip surgery, do NOT bend more than 90 degrees).
- A piece of plastic or a large garbage bag over the cushion may help you to slide in more easily
- You can also try a device called a “Handybar” that can assist you to get in and out of a regular car. This can be purchased at medical supply stores.

Shaded leg is the surgical leg.

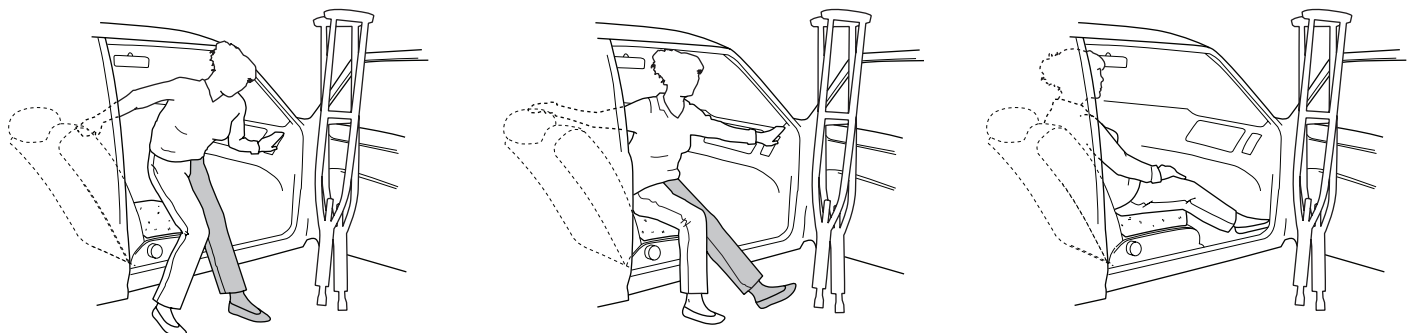

Everyday Activities Guidelines

Walking

You can expect to use walking aids, such as a walker, crutches or cane, for up to 3 months or longer after surgery. By 4 to 6 weeks after your surgery, you should be walking with more confidence, have more strength and be able to walk longer distances. Regular physiotherapy after your surgery will help you get the most out of your new joint. Physical activity will help you have a faster recovery and will get your blood moving. This will also reduce your risk of developing a blood clot.

Stairs

It is a good idea to practice the stairs with the hospital physiotherapist so that you are able to manage stairs safely and independently. If you have had both knees replaced (bilateral), your physiotherapist will practice a technique with you that allows you to alternate your surgical legs when going up and down the stairs. *Shaded leg is the surgical leg.*

Going UP the stairs:

- Use a handrail and/or crutches, cane
- Step UP with your good (non-operated) leg first
- Follow with your operated leg and crutch, one stair at a time

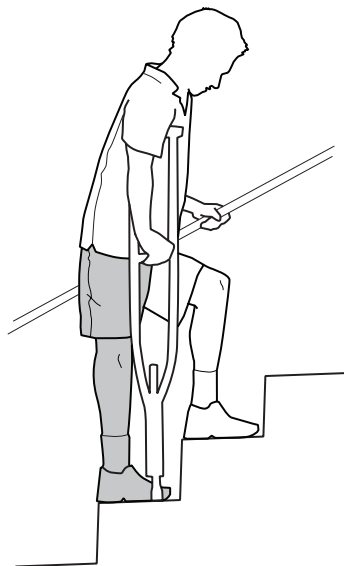

Going DOWN the stairs:

- Use the handrail or your crutches
- Place your crutch on the step below
- Step DOWN with your operated leg first
- Follow with your good (non-operated) leg, one stair at a time

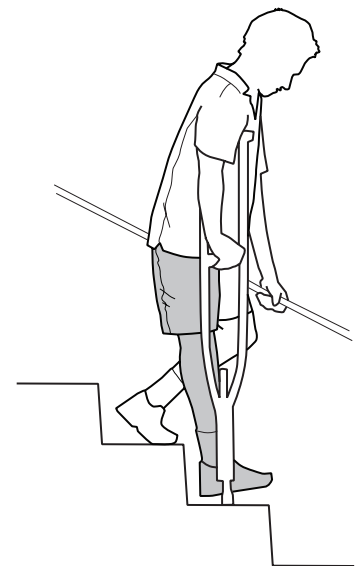

Getting Into Bed

- Sit at the side of the bed. It may be easier to get into bed on your stronger side.
- Slide back across the bed using your arms for support
- If necessary, a ½ bed rail can allow you to get in and out of bed more easily. A ½ bed rail consists of a handle with 2 long metal rods that are placed between the mattress and the box spring. A ½ bed rail can be obtained through the Red Cross or medical supply stores.
- Lift your operated leg into bed or use a “leg lifter” (this may be the belt from your housecoat or a crutch turned upside down, hooked over your foot so you can help lift the leg using your arms) if needed

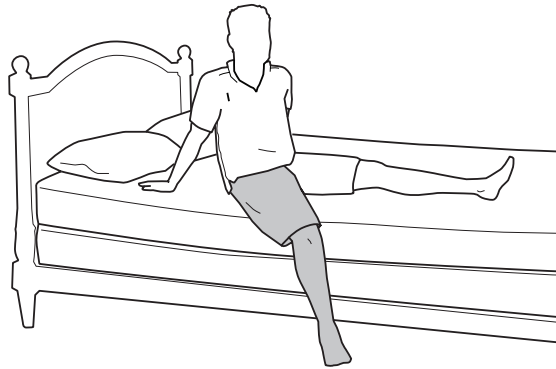

Getting Out of Bed

- Slide your body to the edge of the bed
- Use your arms to push yourself to a sitting position. (If you have had hip surgery, do not push yourself up past 90 degrees. Remember your hip precautions!)
- Slide your operated leg off the bed
- Bring your body to a sitting position at the bedside

Sitting Down

- Use a firm chair with arm rests
- If you have had hip surgery measure the chair height against your leg before you sit. The chair should be 2 inches above your standing knee height. Use a high density foam cushion or bed blocks to increase the chair height.
- Back up to the chair until you feel the edge behind your knees
- Move your operated leg forward and reach back for the arm rests
- Slowly lower yourself into the chair





Getting Dressed

- Sit on a raised chair or bed
- Dress your operated leg first and undress it last
- Use adaptive aids like a long-handled reacher, sock aid and shoehorn to reach the foot of your operated leg and put on socks, pants, shoes, etc. while protecting your new joint
- While you are in hospital, your occupational therapist will show you how to use these aids and give you tips on how to dress while maintaining joint precautions

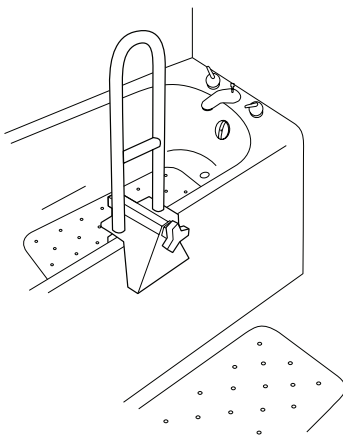

Removable Tub Clamp

Bathroom Safety

Falls can happen anywhere but are most likely in the bathroom. Here are ways to reduce the risk:

- Do not rush. Plan to use the toilet often. Have a bedside commode if needed.
- When bathing, use a bench or chair, non-slip bath mats, grab-bars and/or a removable tub clamp
- Make sure the route from your bedroom to the bathroom is well-lit
- Wear sensible, non-slip shoes or slippers
- If you feel dizzy or unsteady, talk to your family doctor



Raised Toilet Seat

Using the Toilet

- Use a raised toilet seat for the first 3 months after your surgery
- Make sure that the toilet seat has secure armrests or that you can use the counter to push yourself up. You can also install grab bars to help you stand or sit. Do NOT use towels racks or toilet paper holders to help you stand or sit down.
- Toilet seat should be 2 inches above standing knee height
- Sit down as you would in a chair (see [page 49](#))

Bathtub Transfer

- Use a tub transfer bench with a hand-held shower (in a bathtub) or shower chair (in a shower stall) for the first 3 months after surgery. Do NOT try to sit on the bottom of the tub.
- Remove glass shower doors on your tub and replace with a shower curtain
- Place a non-slip bathmat inside and outside the tub
- Your transfer bench or shower chair should be 2 inches above your standing knee height. If you are tall, you may need bench leg extensions.
- Sit down as you would in a chair (see [page 49](#)). Slide back as far as you can on the seat. Then lift your legs over the edge of the tub. Do not bend your hip past 90° if you have had hip surgery.
- Use long-handled aids to clean your feet and other hard-to-reach places
- A hand-held shower hose will allow you to bathe more easily. If you have had a hip replacement, you will not be able to reach forward for the taps due to hip precautions.
- Some surgeons will want you to do sponge-baths until your staples are removed in order to avoid getting the new incision wet

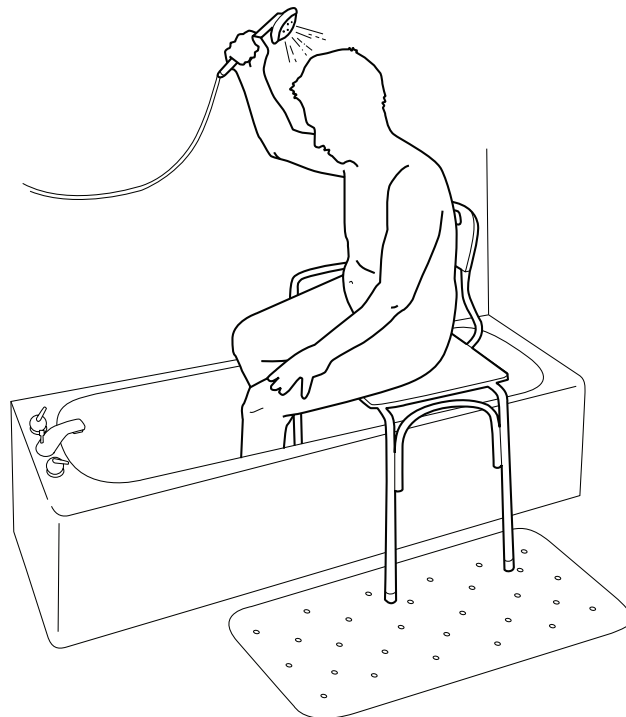

Wound Care

You will have a cut (incision) at the site of your surgery. Your nurse will teach you how to care for your incision at home. While it is normal to have some redness and clear drainage from your wound, watch for signs of infection ([page 56](#)). You do not need a bandage unless there is drainage.

The edges of your skin may be held together with sutures, staples or steri-strips. Staples are metal clips that hold the edges of your skin together while your skin heals. Your staples will be removed 7 to 14 days after surgery. If you have steri-strips, leave them alone. They will fall off on their own.

It is important to keep your incision dry until it is fully healed. You may find it useful to tape a plastic bag or waterproof dressing over your incision while showering unless otherwise instructed by your surgeon.

Sexual Activity After Hip Replacement:

- You may return to sexual activity when you feel ready and comfortable; this is often around 4 to 6 weeks after surgery
- You must maintain hip precautions for 3 months during all daily activities, including sexual activity
- Think about how you will maintain your hip precautions of not twisting and not bending more than 90 degrees
- You may need to consider trying some new positions. Talk to your partner.
- If you have questions or concerns about how to protect your new hip during sexual activity, talk to your occupational therapist, physiotherapist or surgeon.
- Visit the website: www.aboutjoints.com for illustrations of sexual positions that maintain hip precautions

Returning to Work

Allow yourself time to recover from surgery and focus on your rehabilitation before returning to work. Some people return to some form of work quickly after surgery but others need a longer time to heal and recover. This depends on factors such as health status and the type of work you do. Talk to a health care professional, such as an occupational therapist, about what is right for you.

Work Environment Adaptations:

- **Chair:** Choose a standard chair for sitting. Avoid chairs with wheels; they can roll away from you when you are getting up. Use your high-density foam cushion to increase the seat height if necessary.
 - **Desk:** Position your phone, paperwork and computer close to you. If you have had a hip replacement, you should NOT bend forward to reach these items. This will break your hip precautions.
 - **Keyboard Tray:** If you have raised your chair and your desk is too low, use a height-adjustable keyboard tray so that you can sit comfortably while typing.
 - **Schedule:** Plan lots of stretch breaks. Get up and move around frequently. Avoid sitting in the same position for more than 45 minutes at a time.
 - **Bathroom:** Check the height of the toilets at the office and the location of grab bars.
- * Review your workstation before surgery so that you can make the necessary adjustments before you return to work **

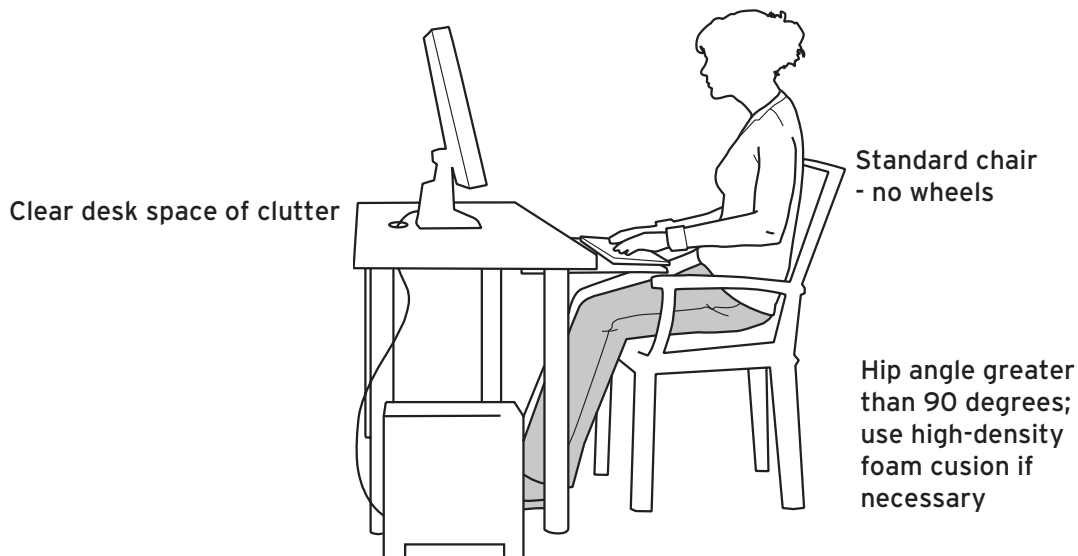

Complications

After surgery, a few people have complications and need more medical treatment. Here are some possible complications:

- Constipation / bladder function
- Short-term confusion
- Blood clots
- Swelling
- Infection
- Anemia (low blood count)
- Joint loosening
- Hip joint dislocation

Short Term Confusion

A small number of people develop short-term confusion after surgery. This may be related to other medical conditions or conditions such as alcohol withdrawal. For example, if you drink alcohol daily, consider cutting back before surgery. If you are unable to cut back the amount of alcohol you drink, tell your nurse so that precautions can be taken to avoid withdrawal symptoms.

Constipation / Bladder Function

Constipation can be a problem after surgery. A change in your diet, less activity and pain medicine may make your constipation worse. Here are some ways to stay regular at the hospital and at home:

- Drink at least 8 glasses of water or low calorie fluid a day
- Eat fibre, such as prunes, bran, beans, lentils, fruit and vegetables
- Move around as much as you can – do your exercises!

Your nurse may give you laxatives and/or stool softeners. You may need to keep taking these medicines at home. If you have constipation at home, talk to your family doctor or pharmacist. Constipation can be serious so do not ignore your symptoms.

Some patients have difficulty urinating after their joint surgery. Please talk to your nurse right away if you are having problems. You may need a catheter.

Blood Clots

A small number of people may get blood clots after surgery. Blood clots usually develop in the deep veins in the legs. People who have problems with their circulation and/or are inactive are more likely to develop a blood clot.

To reduce the risk of blood clots:

- Take the medicine prescribed by your surgeon to prevent blood clots
- Walk short distances at least once an hour (except when you are sleeping)
- When you are sitting or in bed, pump your ankles and flex your leg muscles

Tell your family doctor or surgeon immediately if you have:

- Pain, aching, heat or redness in your calf area
- Increasing severe swelling in your surgical leg

Call 911 immediately if you have:

- Shortness of breath
- Sudden chest pain

Swelling

It is normal to have some swelling in your leg after surgery and during your recovery. Swelling may increase as you become more active. To help reduce swelling:

- Point and flex your feet hourly when awake
- Lie down flat and raise your legs (maintain hip or knee precautions) by placing pillows under the length of your leg
- Do short periods of activity. Walk a few steps. Rest. Repeat.
- Place an ice pack wrapped in a towel on your joint. For some knee clients, a “cryocuff” may be used. This is a type of ice pack / compression device for the lower leg. For more information, talk to your physiotherapist about using ice at home.

Infection

Less than 1% of people have an infection around their new joint. An infection in the body can reach the new joint through the bloodstream. People who develop joint infections need antibiotics and, on rare occasions, further surgery. To prevent infection or incision problems, it is important to keep the incision and dressings dry. Do not touch or pick at the incision and maintain good cleanliness of the surrounding skin.

Tell your doctor or surgeon if you have any of these signs of infection:

Incision Infection:

- The area around your incision is becoming more red and the red is spreading
- New drainage (green, yellow or foul smelling pus) from the wound site. It is common for new surgical wounds to have some drainage for the first few (3-5) days after surgery but this will slowly stop and the wound should stay dry.
- There is increased pain or swelling of wound site and surrounding area
- Fever above 38°C or 101°F
- Call your surgeon if you think you have a possible wound infection

Urinary Tract Infection:

- Pain when you urinate
- Frequent or urgent need to urinate
- Foul smelling urine
- Fever above 38°C or 101°F

Sore Throat/Chest Infection:

- Swollen neck glands, pain when you swallow
- Frequent cough, coughing-up yellow or green mucous, shortness of breath
- Fever above 38°C or 101°F

Anemia (low blood count)

If you have signs of anemia, see your family doctor. You may need an iron supplement. The signs of anemia are:

- Feeling dizzy or faint
- Feeling very tired
- Shortness of breath
- Rapid pulse

Joint Loosening

Over many years, the bond between the joint replacement and your bone may loosen. This can cause pain and make it difficult for you to move your artificial joint. To reduce the risk of this complication, avoid high-impact physical activities. If you notice increased pain in your artificial joint, talk to your doctor as soon as possible.

Hip Joint Dislocation

Call 911 if your surgical leg is suddenly extremely painful, shortens, and the hip cannot be moved.

Dental Work and Medical Procedures

It is important to tell your health care professional that you have had joint replacement surgery before having dental work or medical procedures (including procedures with the bladder, prostate, lung or colon). You may be put on antibiotics to prevent infection from moving through your bloodstream to your new joint. Talk to your dentist or doctor about what is right for you.

We hope you found the information in this booklet useful. We wish you a speedy recovery and many happy years with your new joint.

Resources

Resources

Arthritis & Surgery Information

OASIS Program;
“Osteoarthritis Service
Integration System”
Vancouver Coastal Health

oasis.vch.ca

Phone:

Vancouver: 604-875-4544

Richmond: 604-675-3944

Coastal: 604-904-6177

The Arthritis Society

www.arthritis.ca

Email: info@arthritis.ca

Arthritis Answers Line:

1-800-321-1433

The Arthritis Resource
Guide for BC

[www.arthritis.ca/Provinces/
BC/Resource-Directory](http://www.arthritis.ca/Provinces/BC/Resource-Directory)

Canadian Orthopedic
Association

www.coa-aco.org

Canadian Orthopedic
Foundation

www.canorth.org

and Ortho Connect

www.orthoconnect.org

“My Joint Replacement”
information

www.myjointreplacement.ca

Surgical or Orthopedic
Information

American Academy of
Orthopaedic Surgeons

<http://orthoinfo.aaos.org>

Equipment

Veterans Affairs Canada

www.veterans.gc.ca

Toll Free:

1-866-522-2122

Red Cross

[www.redcross.ca/where-
we-work/in-canada/british-
columbia-and-yukon](http://www.redcross.ca/where-we-work/in-canada/british-columbia-and-yukon)

Toll Free:

1-800-565-8000

or check local listings for
area phone number

Health Professionals

HealthLink BC

Phone: 8-1-1

www.healthlinkbc.ca

Non-emergency health
information provided by
a nurse, pharmacist or
dietitian.

Dietitians of Canada

www.dietitians.ca

Physiotherapy Association
of British Columbia
(PABC)

– to find a physiotherapist
in your area

www.bcphysio.org

Home Safety

Home Safety Renovations
(low income seniors)

www.cmhc-schl.gc.ca

Phone: 1-800-639-3938

Transportation

HandyDART

[www.translink.ca/en/Rider-
Guide/Accessible-Transit/
HandyDART.aspx](http://www.translink.ca/en/Rider-Guide/Accessible-Transit/HandyDART.aspx)

Provided by local bus
services throughout BC
– check your local listings
for phone numbers

In Lower Mainland:

Phone: 604-575-6600

SPARC –

disabled parking pass

www.sparc.bc.ca

Phone: 604-718-7744

TAP – Travel Assistance
Program

www.health.gov.bc.ca/tapbc/

Phone: 1-800-661-2668

**Please note that phone numbers may change and you may need to use directory assistance.*

Index

- acetabulum.....7, 8
- air travel.....46
- anemia.....29, 54, 57
- anesthesia.....31, 35
- bathing.....24, 38, 50
- bed (getting in and out).....49
- bed blocks.....25, 49
- bilateral knee replacement.....16, 37, 48
- blood clots....36, 38, 41, 48, 54, 55
- blood thinner.....36, 41, 55
- both knees.....16, 48
- car transfer.....47
- chest infection.....56
- complications.....54-57
- constipation.....29, 39, 54
- crutches.....23, 26, 32, 38, 48
- daleparin.....41
- day of surgery.....35
- deep breathing and coughing.....36
- Dial-a-Dietitian.....30, 61
- disabled parking pass (SPARC pass).....36, 46, 61
- discharge (hospital).....37
- dislocation (hip).....10, 54, 57
- dressings.....11, 26, 32, 38, 50
- driving.....46
- education.....31
- emergency situations.....55, 56, 57
- equipment.....26, 27
- exercise...28, 36, 38, 40, 45, 46, 54
- falls prevention.....23, 28, 50
- femur.....7, 8, 15
- follow-up.....41
- grab bars.....24, 26, 50, 53
- government agencies.....27, 61
- hand-held shower hose....24, 26, 51
- HandyDART.....27, 46, 61
- heparin.....36, 41, 55
- high density foam cushion...11, 25, 26, 46, 47, 48, 53
- hip precautions.....10, 11, 12, 49, 51, 52, 53
- hip replacement.....8
- hip resurfacing.....8
- hip revision.....9
- home set-up.....23
- ice.....21, 40, 55
- incision infection.....56
- infection.....31, 52, 56
- injection.....36, 41, 55
- intravenous.....35, 36
- joint loosening.....57
- knee precautions.....18
- knee replacement.....15, 16
- knee revision.....16
- knee stiffness.....15, 18
- leg lifter.....49
- length of hospital stay.....37
- lighting.....23
- long-handled reacher.....11, 19, 26, 50
- long-handled shoehorn.....11, 19, 26, 50
- loosening (joint).....54, 57
- Low Molecular Weight Heparin (LMWH).....41
- medical appointments.....14
- medical supply stores.....27
- medication.....39
- nausea.....36, 39
- nutrition.....29
- OASIS.....55
- occupational therapist....38, 47, 49, 52, 53
- office work.....53
- Ortho Connect.....4, 61
- osteoarthritis.....7, 15
- pain.....7, 8, 15, 30, 35, 36, 38, 39, 40, 54, 55, 56, 57
- pain assessment scale.....39
- partial knee replacement.....16
- physiotherapy.....38, 40, 41, 45, 48
- Pre-Admission Clinic.....31
- pre-op checklist.....32
- pre-op education.....31
- prosthesis.....8, 15
- protein.....29
- railings.....23
- raised toilet seat.....11, 19, 24, 26, 36, 50
- recovery room.....35
- Red Cross Loan Cupboards.....27
- rehabilitation.....38
- resources.....61
- returning to work.....53
- revision.....9, 16
- sexual activity.....52
- shower chair.....24, 26, 51
- showering.....24, 32, 51, 53
- sitting.....49
- sleep.....11, 40
- sore throat.....56
- SPARC pass.....27, 46, 61
- spinal anesthetic.....35, 36
- stairs (going up, down).....48
- staples.....8, 15, 41, 51, 52
- steristrips.....52
- swelling.....55, 56
- The Arthritis Society.....61
- toilet transfer.....50
- transportation.....27, 46
- Travel Assistance Program (TAP).....46, 61
- tub clamp.....24, 26, 50
- tub transfer bench.....24, 26, 50
- underweight.....30
- urinary tract infection.....56
- unicompartmental knee replacement.....16
- urinating.....36, 54, 55
- vitamins.....28
- walker.....26, 32, 38, 48
- walking.....28, 45
- weight bearing status.....36
- weight management.....30
- work environment.....53
- wound care.....52
- wound infection.....56

When to seek medical attention

CALL 911 if you develop:

- Sudden severe pain in your surgical leg
- Inability to move the surgical leg
- Shortening of the leg
- Shortness of breath
- Chest pain

CALL your Surgeon if you develop:

- Redness and drainage at the incision site
- Fever
- Severe Fatigue
- Dizziness