



cutting through complexity

Department of Professional Practice

Better Understanding the Process through Flowcharting

An Implementation Guide

August 2014

kpmg.com

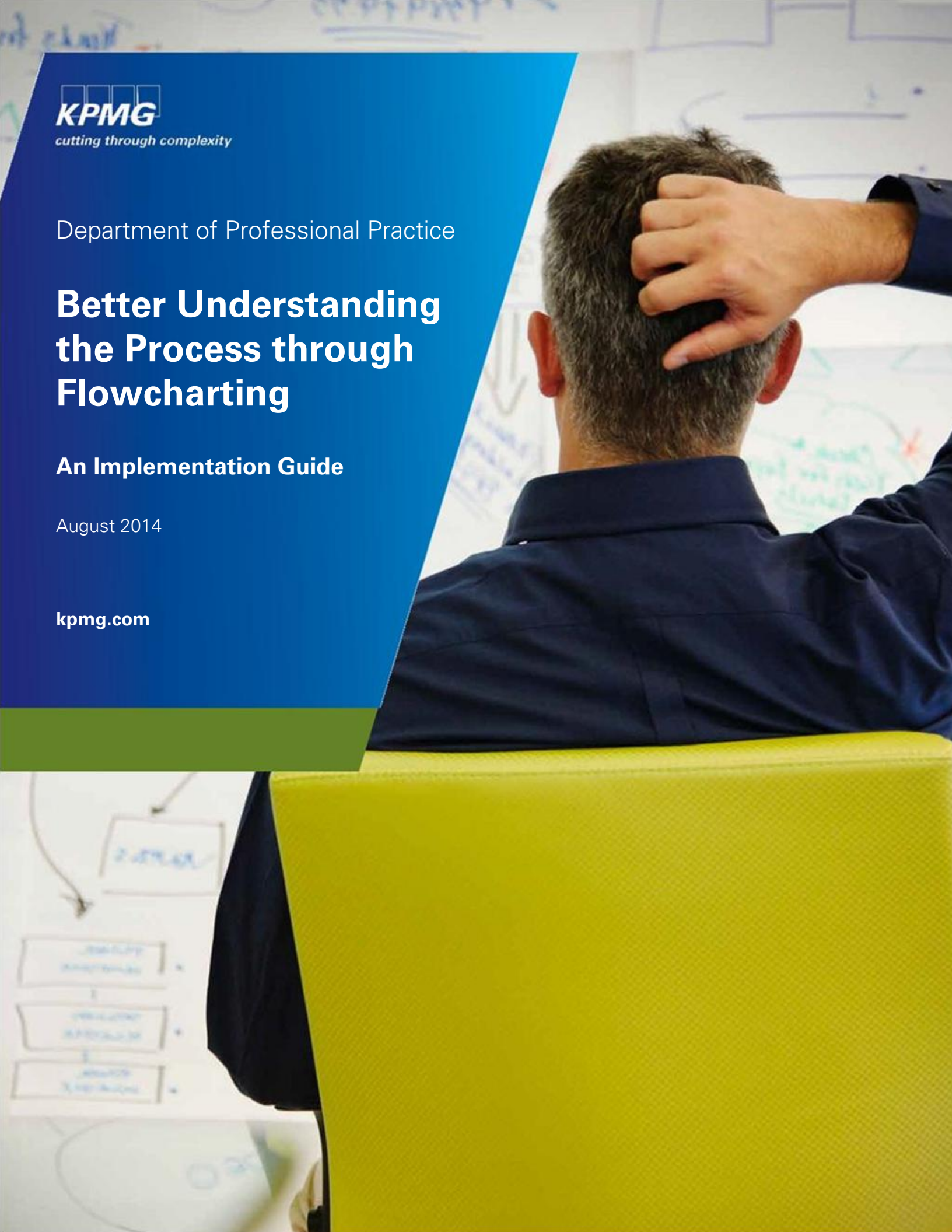



Better Understanding the Process through Flowcharting

An implementation guide

Preface

A picture is worth a thousand words.

The efficiency expert Edward Deming once said: “Draw a flowchart for whatever you do. Until you do, you do not know what you are doing, you just have a job.”

Department of Professional Practice – An Implementation Guide (the Guide) is designed to assist you in developing flowcharts as a tool to enhance your understanding of the flow of information through your entity’s processes and systems, the identification of likely sources of material misstatements in the financial statements and the controls in place to address those potential material misstatements.

The Guide is designed for use by management¹ to help address the requirements, needs and objectives for evaluating and assessing an entity’s internal control over financial reporting in accordance with Section 404 of the Sarbanes-Oxley Act of 2002 and the COSO 2013 Framework published by the Committee of Sponsoring Organizations of the Treadway Commission (“COSO”).

This document is intended for informational and educational purposes and should not be used or relied upon to ensure an entity has met or will meet its responsibility with respect to internal control over financial reporting. Illustrations and guidance included within the Guide are designed to highlight key concepts and are not intended to be comprehensive examples of all elements that you should consider when obtaining an understanding of the respective process.

¹ As this Guide has been designed for use by management, the use of terms such as “you” or “your” refer to employees or other individuals within the entity responsible for internal control over financial reporting.



C O N T E N T S

Background and objectives	2
Introduction to flowcharting	4
Basic flowcharting conventions	4
Standard symbols	5
Developing flowcharts	8
Leverage available information and validate management's understanding	8
Identify the key steps and activities in the process	8
Consider information systems	10
Challenge the flowchart	11
Potential questions to challenge the flowchart	11
Try not to:	12
Conclusion	13
Appendix – Example Flow Chart	

Background and objectives

Who should read this document?

KPMG has prepared this document for management and members of corporate teams responsible for compliance with Sarbanes-Oxley Act Section 404 compliance (SOX 404) and COSO 2013.

Why is it important?

Management is responsible for maintaining a system of internal control over financial reporting² (ICOFR) that provides reasonable assurance regarding the reliability of financial reporting and the preparation of its external financial statements. This includes maintaining evidential matter, including documentation, to provide reasonable support for the assessment of the system.

In its interpretive guidance, the SEC has noted that while the evaluation of ICOFR will vary from entity to entity, “the top-down, risk-based approach...will typically be the most efficient and effective way to conduct the evaluation.” This approach allows management to focus their attention and efforts on the risks that address the potential sources of material misstatement.

Flowcharting will assist management in accomplishing the above in the most effective and efficient manner.

How can flowcharting help?

To properly identify risks, management must obtain an understanding of the flow of information through the financial reporting processes and IT systems. Our experience has shown that a graphical depiction of the process (i.e., a flowchart) provides the best means to demonstrate the flow of information through a process and an IT system. It allows multiple parties to review the same information and understand the flow of information in basic terms from different perspectives within the organization (process owners, IT owners, etc.). It also allows for easier clarification of gaps in controls and risk areas (What Could Go Wrong’s or WCGW) that have not been previously identified. Once management has gained an understanding of the flow of information, it can identify the points in the process at which a misstatement due to error or fraud could arise and would be material—and the controls that have been implemented to address the potential misstatements. Management can then select controls at that point or after that point in the flow to



² As defined in Auditing Standard No. 5 – An Audit of Internal Control Over Financial Reporting That Is Integrated with An Audit of Financial Statements.

address the risks.

We believe that flowcharts are an extremely useful tool to understand, confirm and document the flow of information.

Why is flowcharting better than a detailed narrative?

The flow of information is easier to understand in a visual flowchart than in a long narrative. Flowcharts help:

- Depict the flow of transactions: how they are initiated, authorized, processed and recorded, including when information flows between multiple systems which is a common area where gaps are identified.
- Identify the points within the entity’s processes at which a misstatement – including a misstatement due to fraud – could arise, that individually or in combination with other misstatements could be material.
- Identify the controls, including automated and IT dependent application controls, that have been implemented to address these potential misstatements.
- Identify the controls that have been implemented over the prevention or timely detection of unauthorized acquisition, use or disposition of the entity’s assets that could result in a material misstatement of the financial statements.
- Provide management with the requisite documentation to evidence their assessment of ICOFR.
- Enable management to take a “fresh look” at the process and controls in place, so that they can answer a number of questions, including:
 - “Do we have the most efficient control structure?”
 - “Have we identified all the WCGWs?”
 - “Are there points where automated controls would be more efficient and effective?;and
 - “Do our processes have redundant controls, and conversely, do we have all the WCGWs covered?”

Won’t flowcharting our processes take time and energy?

Converting narratives to flowcharts may take some initial investment. Our experience has shown that many existing Company narratives have some level of deferred maintenance as processes change throughout the years but the narratives haven’t been updated timely. Instituting a flowcharting process to (i) reconfirm the understanding of the process, (ii) reconsider the appropriateness of the controls in place, and (iii) satisfy management’s responsibility to perform risk assessment and fulfill their COSO documentation requirements will create a more effective program and create efficiencies down the road. Once in place, a flowchart can more easily be adapted as processes evolve. Moreover, flowcharting will reduce risk, facilitate a smoother audit and promote a clearer vision of processes and controls. In addition to helping identify missing controls, flowcharts can also help identify redundant controls, and help guide process improvements.



What is the first step to flowcharting?

This Guide provides a framework to prepare process flow diagrams (flowcharts). It covers basic flowcharting conventions and standard symbols and will provide things to consider and do that will assist you in identifying the key steps and activities in the process.

Introduction to flowcharting

A flowchart is a graphic depiction of the steps or activities that constitute a process. The steps or activities used by an entity to initiate, authorize, process and record transactions are represented by various shapes and standard symbols connected with arrows to illustrate the sequence of events.

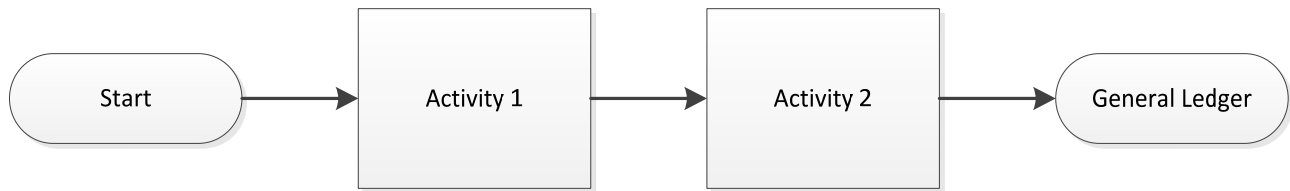

The purpose of a flowchart is to gain an understanding of the end-to-end process, including understanding the key inputs, processes and outputs. Once an understanding of the process has been achieved, management is enabled to properly identify the points in the process where there is a risk of material misstatement, whether caused by error or fraud, and the automated and manual controls in place to address the WCGWs. The preparer should exercise appropriate judgment in determining the appropriate level of detail to present of the process activities in the flowchart. At a minimum, the flowchart should be presented in sufficient detail to ensure that a reader familiar with ICOFR may understand the process and be able to follow a single transaction from the beginning to the end of a process. However, it should not be so detailed that it is redundant with other documentation or difficult to follow.

Basic flowcharting conventions





The following conventions should be followed to ensure basic structural design and consistency:





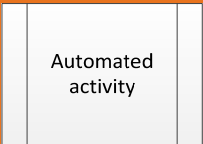

<p>Apply a consistent methodology</p>	<ul style="list-style-type: none"> ■ Present the flow of the transaction from top to bottom and left to right. ■ Use standard symbols to capture key inputs, process activities and key outputs. ■ Use a top down approach to identify risks that could result in a material misstatement.
<p>Identify the process</p>	<ul style="list-style-type: none"> ■ Identify significant accounts and disclosures and determine the underlying processes. ■ Use a separate flowchart for each process. For more complex processes, it may be necessary to break down a flowchart into multiple sub-processes. ■ Clearly identify the process/sub-process on the flowchart (see A in the illustration on page 7).

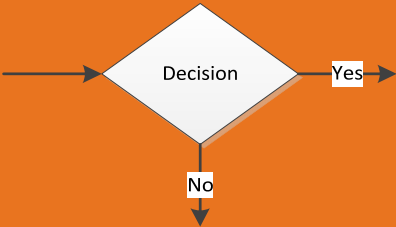
<p>Define the process boundaries</p>	<ul style="list-style-type: none"> ■ Identify the beginning (i.e., initiation of a transaction) and end points (i.e., recording a transaction in the general ledger) of the process (see B in the illustration on page 7) ■ “Begin with the end in mind” – work backwards from the general ledger account to initiation of the transaction.
<p>Consider using rows that depict areas of responsibility for cross-functional processes</p>	<ul style="list-style-type: none"> ■ The rows, or “swim lanes,” can be used to highlight roles and responsibilities through the process (i.e., when processes cross over functional areas). ■ Swim lanes will commonly be the names of departments/functions within the entity (see C in the illustration on page 7).
<p>Follow the transaction data flow</p>	<ul style="list-style-type: none"> ■ The focus should be on capturing the key steps or activities within the process that impact relevant transaction data (i.e., data elements).

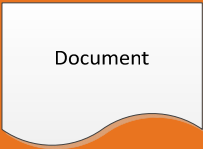
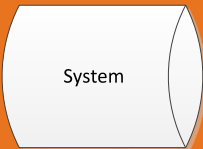
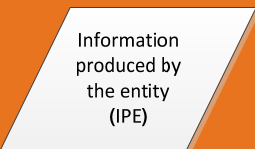
Standard symbols

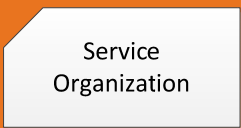
To ensure consistent implementation, the basic elements and standard symbols for use when constructing flowcharts are as follows:

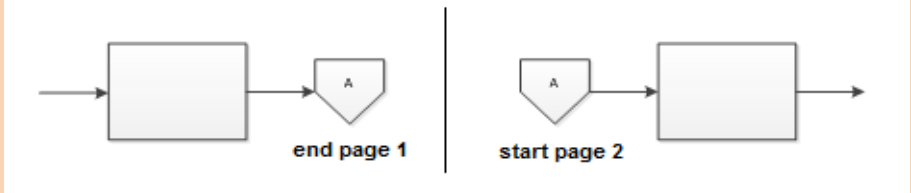
	<p>The start/end icon is used to indicate the beginning (i.e., initiating a transaction) and end point (i.e., recording in the general ledger) of a process. Capture the name of the general ledger account(s) impacted by the transaction inside the end icon.</p>
	<p>The manual activity icon designates a manual step or activity in the process. Within the shape, include a brief description of the manual process activity being performed.</p>
	<p>The automated activity icon designates a step or activity occurring inside the system (i.e., system configured to process data). Within the shape, include a brief description of the automated process activity being performed.</p>
	<p>The arrow connects the steps and activities in the process. The arrowhead indicates the direction or sequence of events.</p>
	<p>The decision icon designates a decision point from which the process branches into two or more paths. The path taken depends on the answer to the question.</p> <p>The icon should be populated with a question and the responses (i.e., yes/no) should be noted in the arrows originating from the decision box. Decisions may be manual or system driven.</p>

 <p>Document</p>	<p>The document icon represents a document (e.g., sales order, contract, supplier’s invoice, etc.) used during the process. Capture the document name inside the icon.</p>
 <p>System</p>	<p>The system icon represents a data file or database where information is stored prior to use in another activity (i.e., pricing master file). Capture the data file or database name inside the icon.</p>
 <p>Information produced by the entity (IPE)</p>	<p>The IPE icon represents a data file or report generated as an output of the system and used in the performance of a control. Capture the report name and relevant data elements inside the icon.</p>
 <p>Annotation</p>	<p>An annotation allows the preparer to document critical information (e.g., relevant data elements of IPE) that may not fit inside the related icon. Lengthy text descriptions can be captured inside the annotation icon itself or cross-referenced to another document or footnote.</p>
 <p>Service Organization</p>	<p>The service organization icon is used to show where information in a process is transmitted to/from a service organization.</p>
 <p>Off-page connector</p>	<p>While there is no ideal size, a flowchart can range from one to several pages. Therefore, it is likely that complex processes will continue onto an additional page or link to another process. The off-page connector icon provides a visual cue that the flowchart continues on another page or another process.</p> 
  <p>WCGW 1</p> <p>Control 1</p>	<p>The WCGW icon identifies the points within the process at which a material misstatement could arise.</p> <p>Once the WCGWs have been determined, identify and document the controls implemented to address these risks.</p> <p>The WCGW and control icons are included within the flowchart. These icons should refer to separate documentation that includes a description of the WCGW and the control(s) designed to address each WCGW. An example of this is included in the illustration on page 10.</p>

The following illustration is intended to highlight the basic structure of a flowchart for a purchase to pay process. It is not intended to be a comprehensive example of all elements that should be considered when obtaining an understanding of

the purchase to pay process and does not include any descriptions of the activities within the process (an example of these is included on page 10).

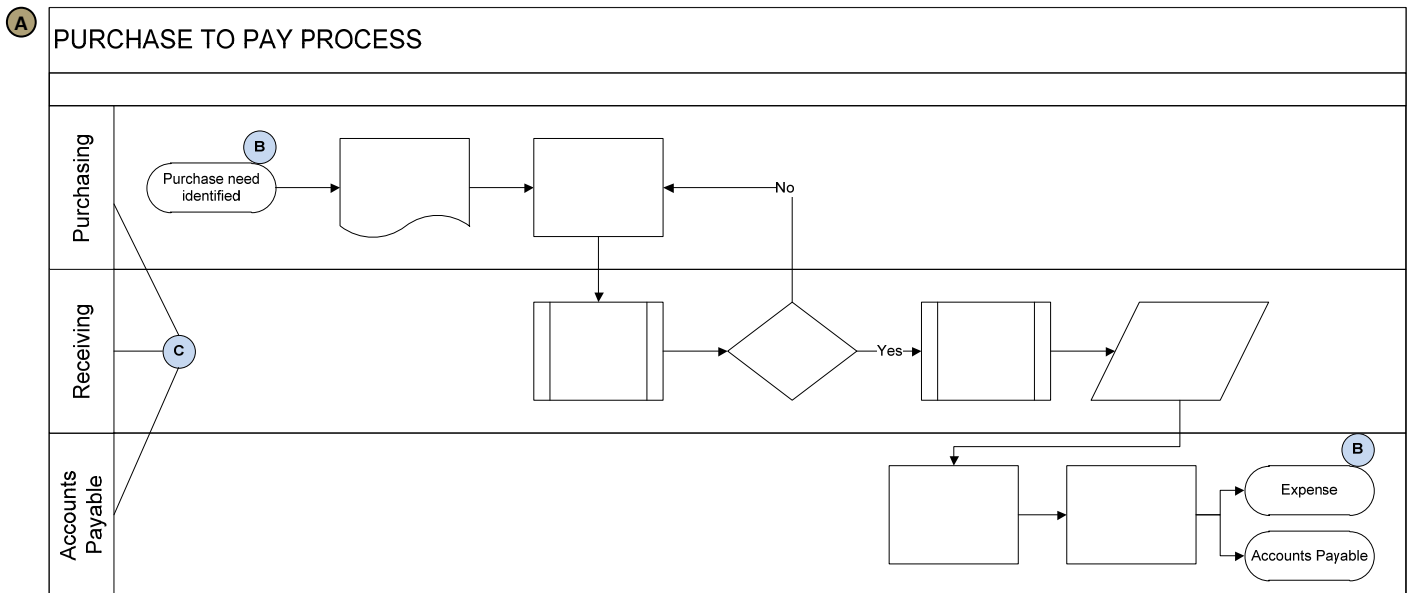

Developing flowcharts

↘ Leverage available information and validate management's understanding

Leveraging all available information, including any existing description of the process and walkthrough, will expedite the ability to develop effective flowcharts. When gathering and reviewing available information, consider the following:

- Who is involved in the process (i.e., individuals, departments, etc.)?
- What are the process boundaries – the beginning (i.e., initiating a transaction) and end points (i.e., recording in the general ledger) of the process?
- What are the key activities in the process? How often are they performed and in what order do they occur?
- Which IT applications are relevant to the process?
- What reports are generated as an output of the process and used in the performance of a control?
- What are the points in the process at which a material misstatement could arise (WCGWs)?
- What controls has management implemented to address these WCGWs?

Current documentation should serve as a starting point to update your understanding of the process activities, the likely sources of potential material misstatements and the controls designed to prevent or detect such misstatements. While not required, performing walkthroughs will frequently be the most effective way of following a transaction from its origination through the entity's processes, including information systems, until it is recorded in the entity's financial records. This will assist you in identifying the activities involved in the process, identifying potential misstatements and the controls in place. Walkthrough procedures usually include a combination of inquiry, observation, inspection of relevant documentation and re-performance of controls.

↘ Identify the key steps and activities in the process

In order to maximize the effectiveness of the flowchart, the following techniques may be utilized during its development:

Identify the initial inputs to the process	<ul style="list-style-type: none"> ■ Every transaction originates from one of three sources: (1) a source outside the entity, (2) a department or IT system not shown in the flowchart or (3) a department or function referenced in the flowchart.
Depict each successive step in the process (both manual and automated) in a logical sequence	<ul style="list-style-type: none"> ■ The description of each process activity should be short and concise, but detailed enough for a reader to understand the event, action or decision. ■ Describe key events, actions, or decisions as they occur until transactions are recorded in the general ledger and the process is concluded. ■ The description of the activity should be presented in enough detail to understand what is occurring at each step.
IT related controls	<ul style="list-style-type: none"> ■ Identify the IT relevant controls and processes in the flowchart including the WCGWs and describe the risks related to IT controls. ■ Involvement of IT personnel may be required.

<p>Identify the key outputs of the process</p>	<ul style="list-style-type: none"> ■ Show the final disposition of all transactions. Every transaction should terminate in one of three places: (1) a destination outside the entity, (2) a department or IT system not shown on the flowchart or (3) the general ledger. ■ Understand how data is entered and processed into IT systems and understand the flow of data from initiation to where it is recorded in the financial statements.
<p>Identify the points within the process at which a material misstatement could arise (WCGW)</p>	<ul style="list-style-type: none"> ■ See WCGW1 in the illustration on the following page.
<p>Link the WCGWs identified to the controls implemented to address these risks</p>	<ul style="list-style-type: none"> ■ See Control 1 in the illustration on the following page.

The following illustration is intended to highlight the basic elements of one component (accounts payable) of the purchase to pay process. This flowchart is not intended to be a comprehensive example of all elements engagement teams should consider when obtaining an understanding of the purchase to pay process. While the illustration highlights only one WCGW and key control, there are likely many other WCGWs and key controls in this process. See Appendix for example flowchart.

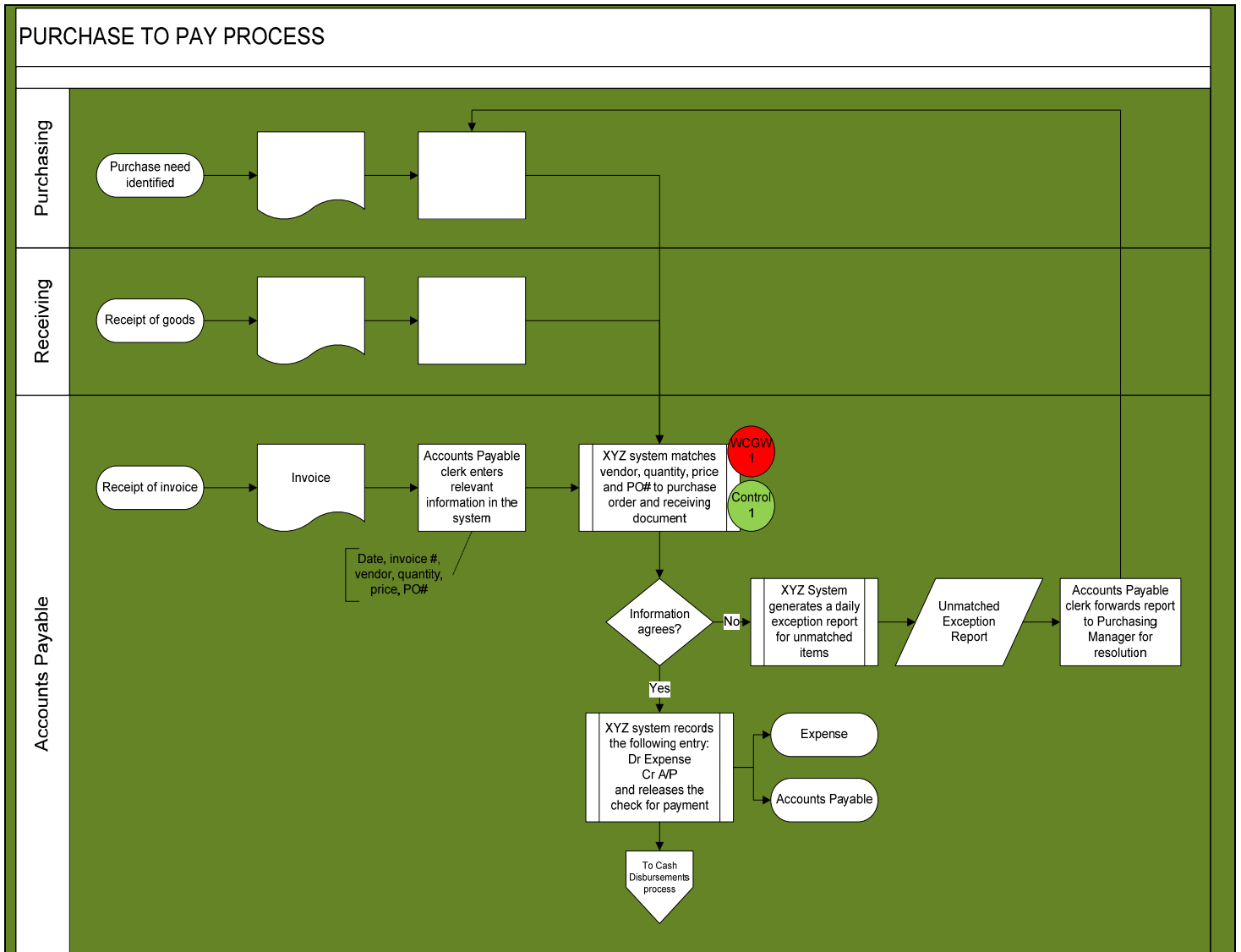

Example narrative descriptions to be maintained and referenced to the flowchart:

WCGW 1: Quantity and/or price do not match approved purchase order and invoice received, resulting in processing of invoices at incomplete and/or inaccurate amounts.

Control 1: The system is configured to perform a three-way match between the purchase order, invoice, and receiving document. Exceptions outside a defined tolerable range are identified and not processed.

➤ **Consider information systems**

Information systems are a key component of processes and controls. Understanding the flow of transactions includes understanding how data is entered into IT systems and how it is stored, processed and accumulated for use in operating controls and preparing financial statements. Additionally, management should understand how data associated with the transaction flows through the various information systems, including applications, databases and other system components.

Your understanding of relevant IT systems, including information as it flows into, through and out of the relevant IT systems, may be enhanced by using IT Systems Diagrams (ISDs). These diagrams also will assist in identifying WCGWs and relevant controls. An ISD should be developed prior to development of a process flowchart as it will help you to understand ITs relevance and role within the process.

ISDs are not flowcharts; rather, they are diagrams that depict the different layers of IT. ISDs show relevant applications, databases, operating systems and other network infrastructure. ISDs will often show how service organization systems that interact with internal IT systems are involved. An example diagram is included below:

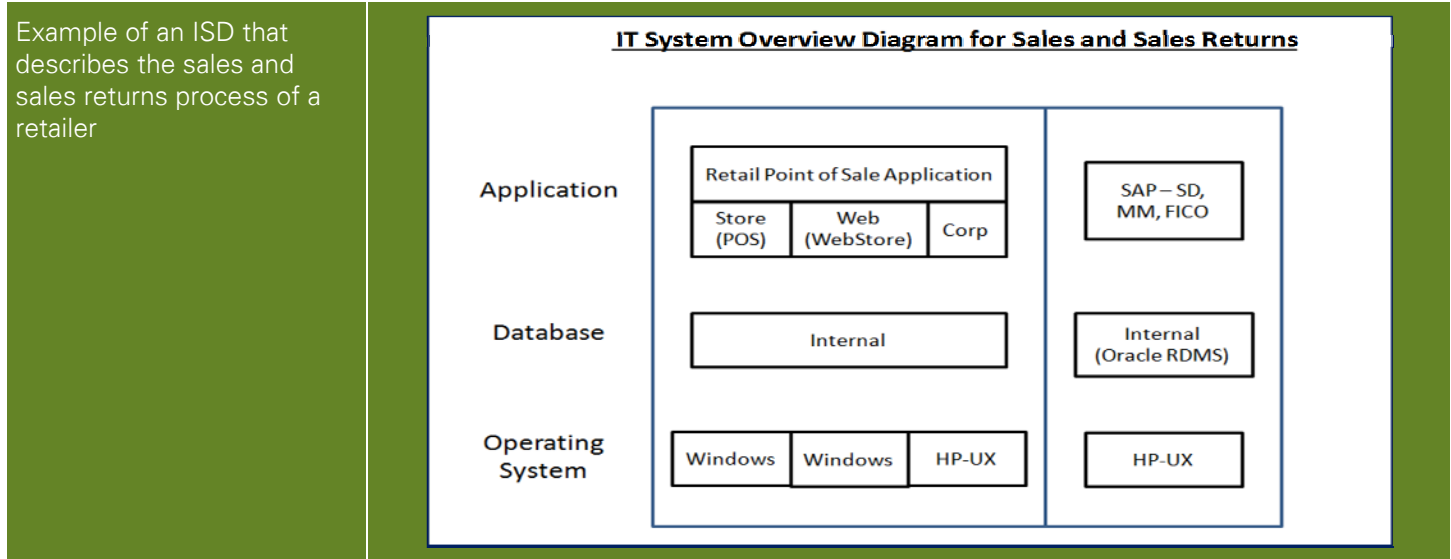

➤ Challenge the flowchart

Flowcharting is a highly iterative process. Challenge the sufficiency of the flowchart by leveraging knowledge gained through discussions with process owners, prior knowledge of the entity and the results of the walkthrough to obtain a comprehensive representation of the process, systems and controls. Constructing a flowchart on a whiteboard or another electronic alternative with the process owners and IT personnel is one approach that may assist in identifying gaps and redundancies in your understanding of the process. This approach may also assist in reaching consensus on the points within the process where a material misstatement likely could occur and the controls designed to prevent or detect such misstatements.

➤ Potential questions to challenge the flowchart

- Does the information flow properly (from top to bottom and from left to right)?
- Does the flowchart contain only information that is relevant to the financial reporting process?
- Are the process activities distinct from the controls?
- Have all relevant data elements (i.e., date, party, description, quantity and price) been identified?
- When data is transferred to or from one system to another, are all WCGWs considered?

- Have all relevant applications been depicted in the flowchart?
 - Have you considered the ISD?
- Are there sections of the process that you don't fully understand after the initial draft of the flowchart?



Try not to:

- Include too much detail
- Treat IT as a black box
- Create loops in the flow
- Reverse the direction in the flowchart unless the flow reverses itself in reality
- Make the process description too lengthy or too brief
- Provide differing levels of detail at similar steps in the process
- Cross flow lines (if avoidable)

Conclusion

Flowcharting can be an effective way to document the flow of information through an entity's processes and systems. This Guide was designed to assist management in implementing flowcharting and to provide a common language, symbols and approach to be used to use a "picture to replace a thousand words."



Appendix – Example Flow Chart - Sales Return Reserve Flowchart with WCGWs and Controls

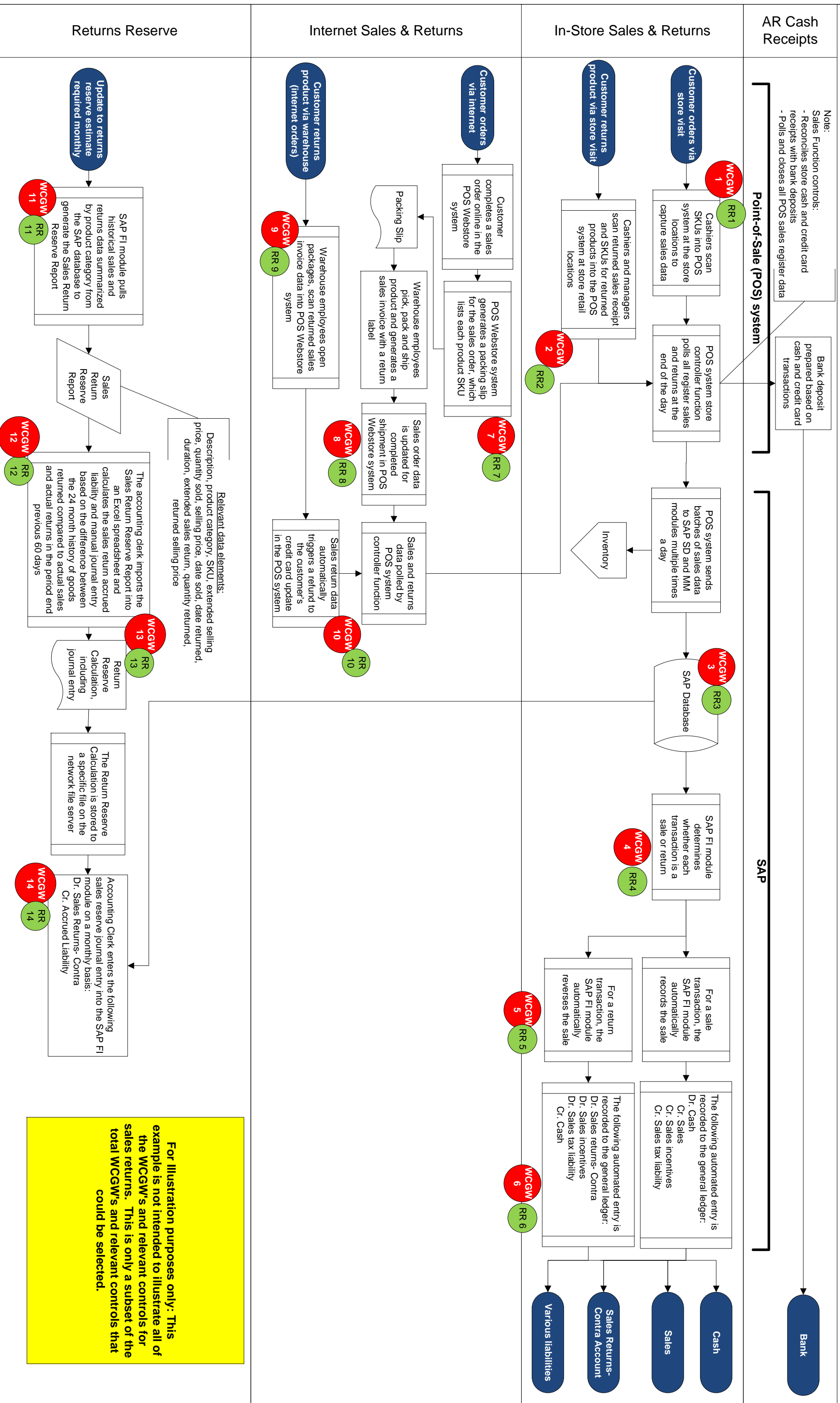

kpmg.com