

Position Control System Products

Position Feedback Cylinders 7.3-7.4



Position Feedback Cylinders
Non-Contact 7.5-7.9

Position Feedback Cylinders 7.10-7.14

Position Feedback Cylinder
Rod Lock 7.15-7.16

Position Feedback Cylinder
Accessories 7.17-7.20

Position Feedback Pneu-Turn 7.21-7.29

Position Control System 7.30-7.41

Digital Panel Meter 7.42-7.47

Electronic Controller 7.48-7.50

PFC/PCS Application Checklist 7.51-7.52

PTF Application Checklist 7.53

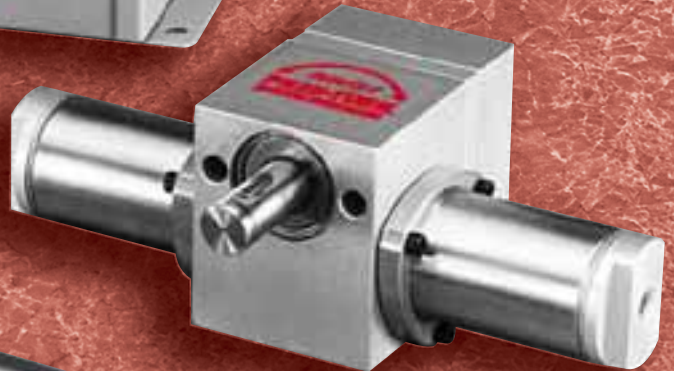

Bimba Position Feedback Cylinders

The Bimba Position Feedback Cylinder provides continuous position sensing in a lightweight, small-bore air cylinder.

Ideal for applications where magnetic position sensing is impractical, where variations in cylinder speed or stroke are needed, or where an operation requires constant monitoring of cylinder position.

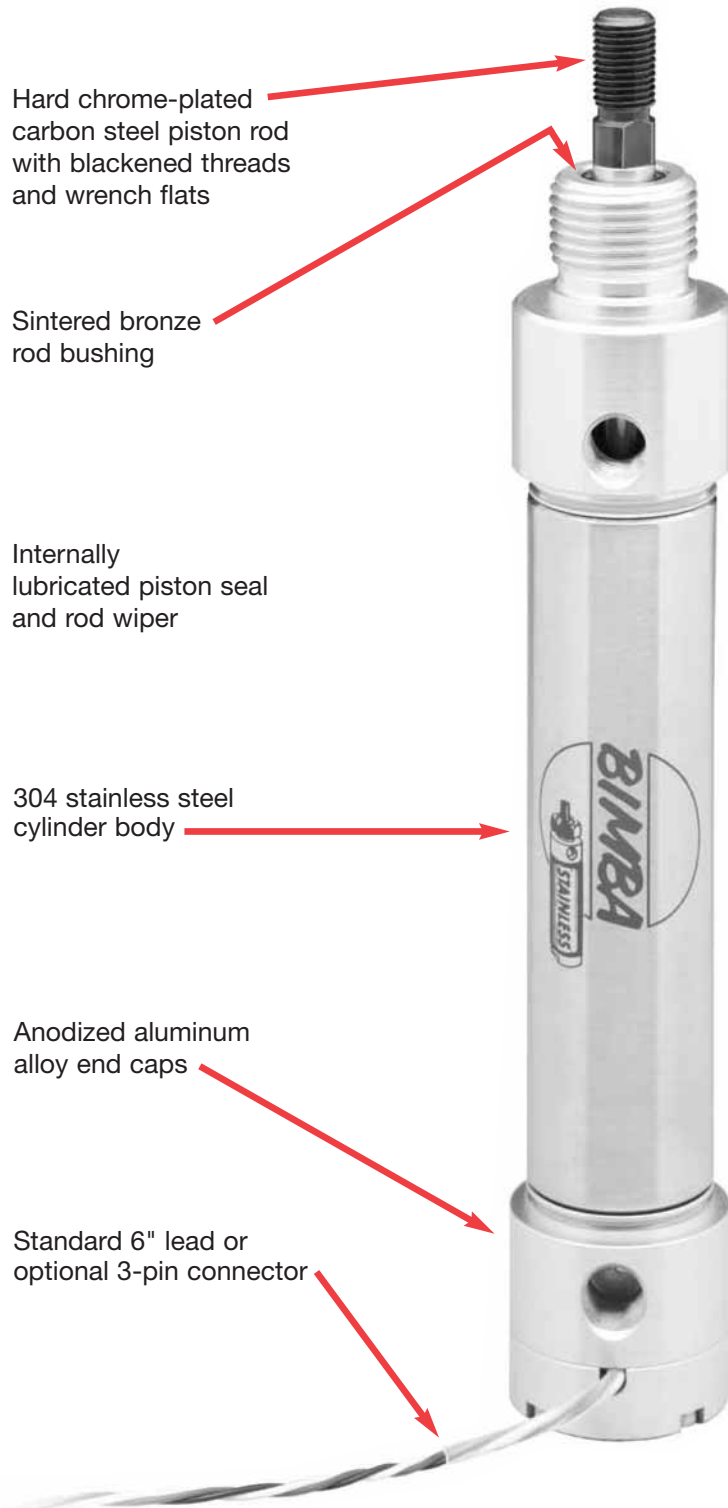

Advantages

- Highly accurate: infinite resolution, linearity of ± 1 percent of full stroke, ± 0.001 " mechanical repeatability.
- Less than 0.75" longer than conventional magnetic piston cylinders.
- Reduces weight and size.
- Repairable.
- Internally-lubricated seals.
- Standard wipers and piston bearing strips for long cylinder life.
- Optional bumpers.
- Choice of standard 6" lead wire or 3-pin connector.
- Electronic controllers available for dual set point and scalable analog output applications.
- Rear head cap can be rotated for optimal positioning of lead or connector.

Bimba Position Feedback Cylinders

This section contains Bimba's Position Feedback Products. These products are ideal for applications that require increased flexibility and adaptability. They are perfect for automated assembly processes that require quick changeovers or for mass customized product assembly.

The Position Feedback Cylinder (Model PFC) is a linear pneumatic actuator that contains an internal LRT (Linear Resistive Transducer). The PFC can be used for measuring and gauging, positioning, and "on-the-fly" applications. It is available with or without a rod lock. Combine the PFC with the Bimba Pneumatic Control System Model PCS, Digital Panel Meter Model DPM, or the Electronic Controller described below to maximize performance.

The Position Feedback Cylinders Non-Contact (Model PFCN) is similar to the original Model PFC, except it employs a magnetostrictive sensor instead of a LRT. The new technology is ideal for applications that involve dirty or moist environments, rapid oscillation over a small increment of stroke, and vibration. In addition, it is relatively immune to air line contamination. It is calibrated to produce exactly 0 volts fully retracted and 10 volts fully extended. Like our original PFC, it is available with or without a rod lock.

The PneuTurn rotary actuator with position feedback (Model PTF) is a rotary rack and pinion actuator that has a rotary potentiometric feedback transducer attached to the output shaft. The PTF can be combined with Bimba's Pneumatic Control System Model PCS described below for closed loop rotary positioning.

The Pneumatic Control System (PCS) is a closed loop pneumatic motion control system that controls the position of the PFC rod or the PTF shaft. The system includes the control electronics and valves necessary to accurately control any Bimba position feedback actuator.

The Digital Panel Meter (Model DPM) is a digital panel meter that has a 16 bit A/D converter and built in microprocessor. When combined with the PFC, the repeatability is 0.001 inch per inch of stroke. The DPM is great for accurate measuring and gauging applications. It is easily calibrated to indicate actual displacement and includes multiple programmable set point outputs. Recommended applications include Go/No Go in-process quality control verification, part identification, and dimensional verification.

The Electronic Controllers can be used for applications that require accuracy larger than ± 0.030 ". It has 10 VDC transducer excitation and fast responding scalable analog output capability. It is good for applications that use controllers that do not have the required PFC input impedance of 1 Mohm.

Position Feedback
Cylinders

Position Feedback
Cylinder Non-Contact

Position Feedback
Cylinder Rod Lock

Position Feedback
Cylinder Accessories

Position Feedback
Pneu-Turn

Position
Control System

Digital Panel Meter

Electronic Controller

PFC/PCS/PTF
Application Checklist

Bimba Position Feedback Cylinders

Applications

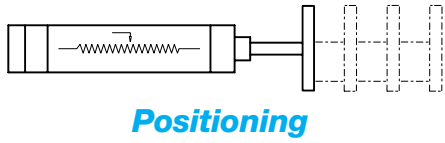

Positioning

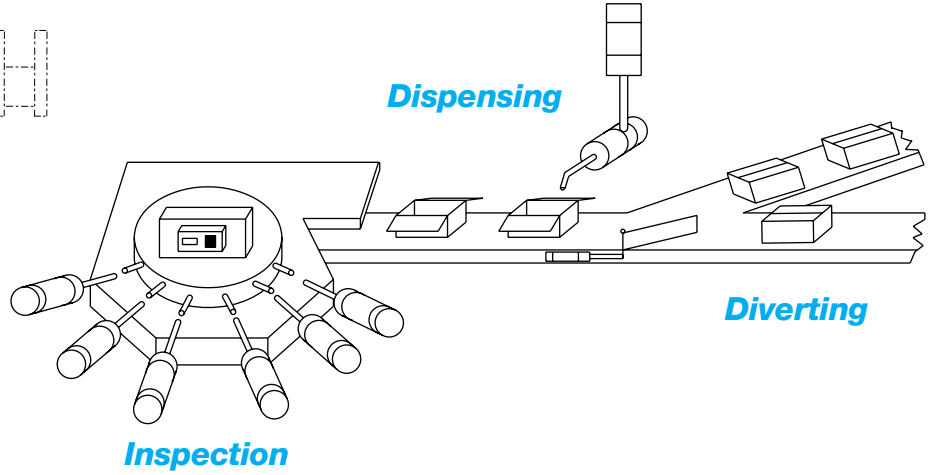

Dispensing

Diverting

Inspection

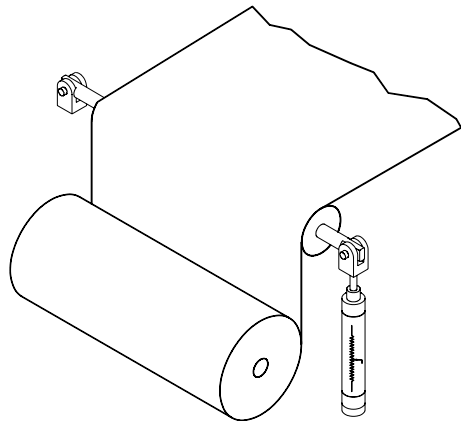

Web Guide

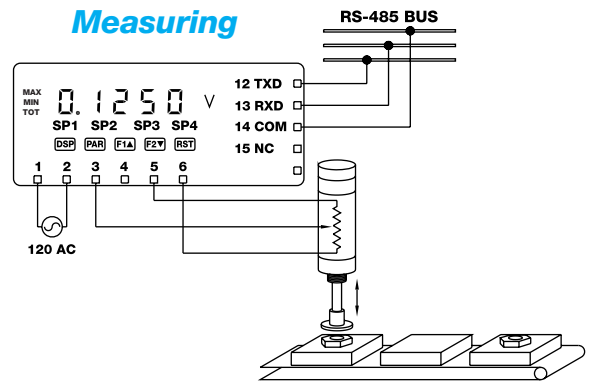

Measuring

RS-485 BUS

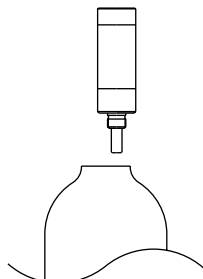
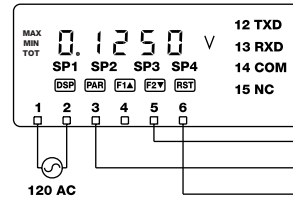

Verification

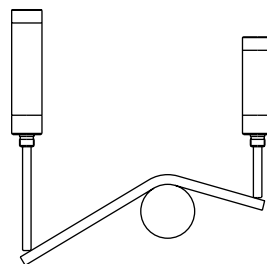

Process Acceptance

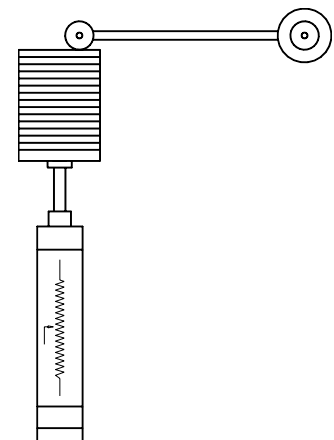

Stacker

Bimba Position Feedback Cylinders Non-Contact

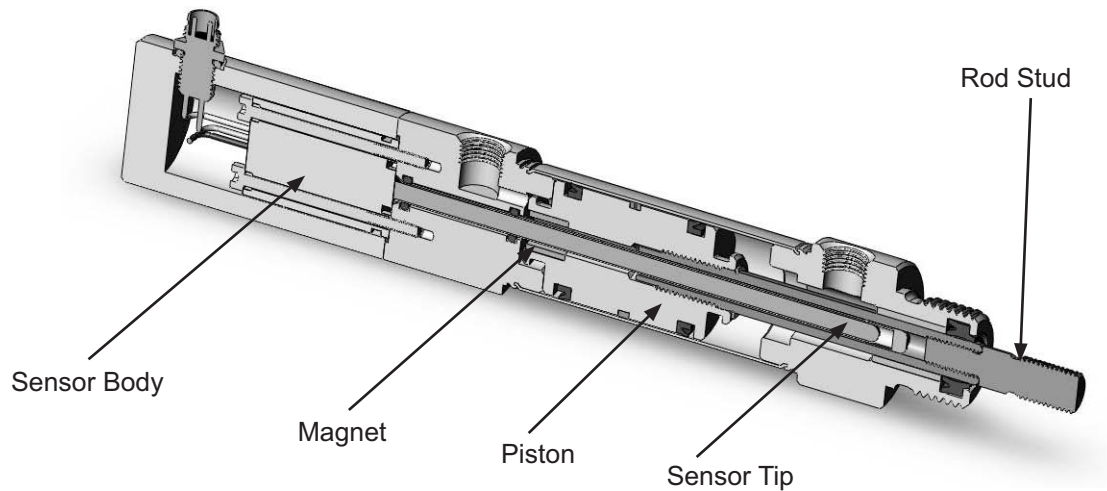

Bimba's Non-Contact Position Feedback Cylinders employ a new magnetostrictive sensor. The sensor tip, fixed inside the cylinder, senses position as a magnet mounted to the piston moves back and forth across the sensor tip's length. This provides many important advantages, and makes the Non-Contact Position Feedback Cylinder the preferred solution for closed-loop pneumatic positioning applications.

- The PFCN is immune to many of the conditions that deteriorate older technology PFC's, such as the presence of moisture, dirt, dirty air lines, and debris generated as pneumatic products wear, especially at high speeds.
- The PFCN is immune to wear from oscillation back and forth over a narrow range of stroke.
- The PFCN is calibrated for 0 volts fully retracted and 10 volts fully extended for all stroke lengths. Both offset and scale factor are user adjustable. This simplifies installation of multiple cylinders in an application and recalibration of replacement cylinders.
- The PFCN connector is sealed to IP68.

Avoid applications that subject the non-contact PFC to:

- Side loads (Guiding is required. For detail on acceptable side loads contact Bimba Technical Support.)
- High speeds above 10 in/sec with no means to control impact energy at end of stroke
- High temperatures over 200° F
- Low temperatures below -20° F
- High electric or magnetic fields

Position Feedback
Cylinders

Position Feedback
Cylinder Non Contact

Position Feedback
Cylinder Rod Lock

Position Feedback
Cylinder Accessories

Position Feedback
Pneu-Turn

Position
Control System

Digital Panel Meter

Electronic Controller

PFC/PCS/PTF
Application Checklist

Bimba Position Feedback Cylinders Non-Contact

How to Order

The model number of all Non-Contact Position Feedback Cylinders consists of three alphanumeric clusters. These designate product type, bore size, stroke length, mounting style, and options. The example below describes

PFCN-316-XBYN, a non-contact Position Feedback Cylinder with 2 inch bore, 6 inch stroke, universal mount, low friction option, and a matching PCS controller with no enclosure.

PFCN - 316 - XL - YN

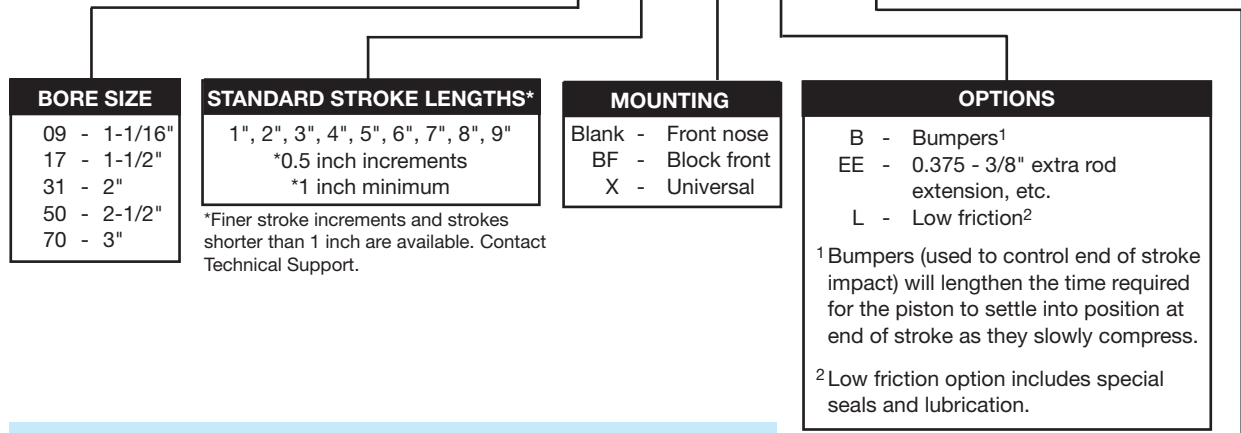

Approximate Power Factors

1-1/16" = 0.9	For example, a PFCN-096-BF will exert a force of 0.9 times the air lines pressure; a PFCN-506-XB will exert a force of 5.0 times the air line pressure.
1-1/2" = 1.7	
2" = 3.1	
2-1/2" = 5.0	
3" = 7.0	

CONTROLLER
Blank - none
Y - PCS, enclosure
YN - PCS, no enclosure
YQ - PCS, quick connects, enclosure
See PCS controllers, page 7.30

When ordering the controller option (Y, YN, YQ), the low friction option (L) MUST also be ordered.

Specifications

Positioning error due to temperature		
Microns/°C	Inches/°C	Inches/°F
20	0.000787	0.000437

- Operating temperature: -20° to 200°F (-28° to 93°C)
- Accuracy: ± 0.012 inch maximum anywhere along the stroke (calculated value combining Non-Linearity, Repeatability, Hysteresis effects at a constant temperature)
- Non-Linearity: ± 0.010 inch
- Repeatability: ± 0.006 inch
- Hysteresis: ± 0.001 inch
- Signal output: 0 V DC ± 6 mV retracted and 10 V DC ± 6 mV extended, all stroke lengths (into 100 kOhms minimum and 300 pF maximum)
- Excitation (Supply) Voltage: 24 ±10% V DC (50mA maximum current)
- Maximum end of stroke impact speed: 10 in/sec.
- Rated Life of the Cylinder: 1400 linear miles (at 10 inches/sec, no load, room temperature dry, 5 micron filtered air, continuous cycling)
- Over voltage and reverse polarity protection
- Cylinder RoHs compliant
- IP-68 rated connector standard

Note: The device that digitizes the PFCN feedback output must have an input impedance of at least 100 kOhms.

Bimba Position Feedback Cylinders Non-Contact

Estimated Cylinder Weights (lbs.)

	1-1/16"	1-1/2"	2"	2-1/2"	3"
PFCN	0.81	1.35	2.48	3.93	5.68
PFCN-X	0.82	1.43	2.59	4.10	5.87
PFCN-BF	0.95	1.57	2.90	4.64	6.79
Adder WT/IN	0.05	0.08	0.14	0.18	0.24

List Prices

Bore	Base	Stroke Adder (per inch)	Mounting		Options			*Controller		
			BF Block Front	X Universal	B Bumpers	EE Extra Extension (per inch)	L* Low Friction	*Y	*YN	*YQ
1-1/16" (09)	\$465.00	\$15.30	\$17.70	\$4.90	\$4.40	2.85	\$13.00	\$510.00	\$540.00	\$600.00
1-1/2" (17)	498.00	18.35	19.05	5.75	5.35	7.00	13.00			
2" (31)	539.00	21.25	23.10	7.20	6.90	9.30	13.00			
2-1/2" (50)	584.00	24.25	27.90	9.05	8.65	12.00	13.00			
3" (70)	636.00	27.40	35.80	12.00	13.00	12.00	13.00			

*Specify option L for closed loop position control applications requiring optimal positioning performance. Use Bimba PCS Controls for best results (options Y, YN, YQ).

Accessories

Bore	Mounting Nut	Mounting Bracket	Rod Clevis	Pivot Bracket
1-1/16" (09)	D-2545	D-8316	D-8310-A	D-8322-A
1-1/2" (17)	D-8484	D-8318	D-8311-A	D-8324-A
2" (31)	D-508	D-8319	D-8313-A	D-8325-A
2-1/2" (50)	D-2540	D-8320	D-8314-A	D-8326-A
3" (70)	D-5379	D-19127	D-8314-A	D-8326-A

Controllers

- PCS closed loop position control systems are described on pages 7.29 through 7.39. Please use the table on page 7.35 to select the right PCS control for your PFC cylinder.
- DPM meters, ideal for measuring and gauging, are described on pages 7.47.

Cables (for connection to standard plug connector)

Model	Description	Price
C4-S	Straight Female Shielded Cord Set IP67, 2m	\$28.95
C4X-S	Straight Female Shielded Cord Set IP67, 5m	44.85
C5-S	Right Angle Female Shielded Cord Set IP67, 2m	28.95
C5X-S	Right Angle Female Shielded Cord Set IP67, 5m	44.85

Bimba Position Feedback Cylinders Non-Contact

Nose mount

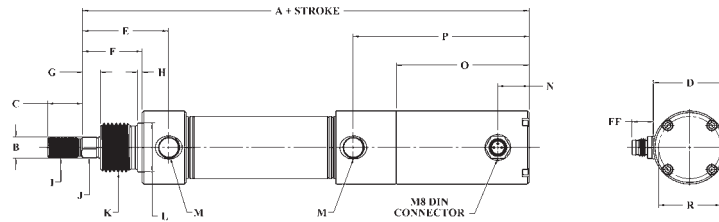

Universal Mount (for stud or pivot). Includes bushing.

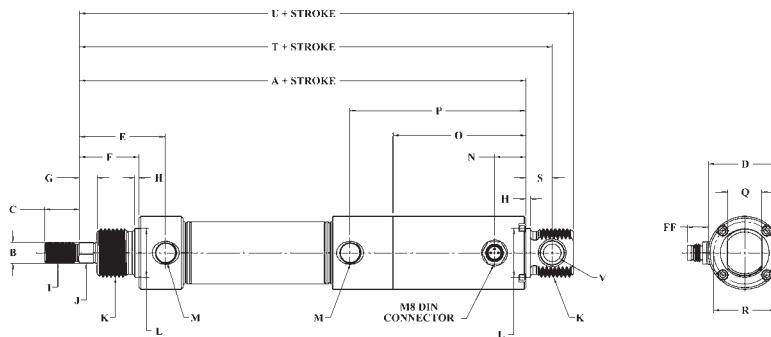

Block Mount

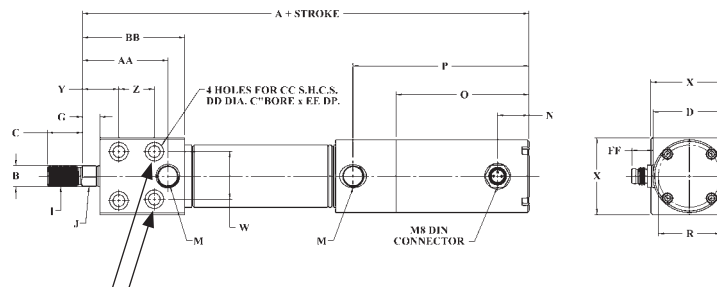

These two holes are not present on 09 bore only

Dimensions (in.)

Bore	A	B	C	D	E	F	G	H	I	J	K	L	M	N
1-1/16" (09)	7.47	0.38	0.63	1.31	1.54/Option L 1.52	1.06	0.31	0.08	3/8-24 UNF	0.31	7/8-14 UNF	0.87	1/8 NPT	0.56
1-1/2" (17)	7.80	0.50	0.88	1.58	1.72	1.13	0.31	0.09	7/16-20 UNF	0.44	1-1/8-12 UNF	1.12	1/4 NPT	0.56
2" (31)	7.75	0.63	1.00	2.09	2.10	1.38	0.38	0.11	1/2-20 UNF	0.50	1-1/4-12 UNF	1.25	1/4 NPT	0.40
2-1/2" (50)	8.31	0.75	1.25	2.58	2.28	1.50	0.44	0.13	5/8-18 UNF	0.63	1-3/8-12 UNF	1.37	3/8 NPT	0.40
3" (70)	8.62	0.75	1.25	3.13	2.53	1.69	0.44	0.13	5/8-18 UNF	0.63	1-1/2-12 UNF	1.62	3/8 NPT	0.40

Bore	O	P	Q	R	S	T	U	V	W	X	Y	Z	AA	BB	CC	DD	EE	FF
1-1/16" (09)	2.38	3.14	0.62	1.11	0.47	7.94	8.31	0.31	0.88	1.38	0.75	N/A	1.52	1.82	#10	0.33	0.20	0.38
1-1/2" (17)	2.38	3.25	0.74	1.33	0.56	8.36	8.83	0.38	1.25	1.75	0.69	0.75	1.68	2.00	1/4	0.41	0.25	0.38
2" (31)	2.03	2.91	0.86	1.63	0.66	8.38	8.88	0.44	1.44	2.25	0.75	1.00	1.75	2.41	3/8	0.58	0.39	0.38
2-1/2" (50)	2.00	3.03	0.99	2.06	0.75	9.06	9.69	0.50	1.88	2.75	0.88	1.25	2.13	2.72	7/16	0.67	0.45	0.38
3" (70)	2.00	3.03	0.99	2.44	0.81	9.43	10.06	0.50	2.25	3.25	0.94	1.38	2.31	2.91	1/2	0.77	0.52	0.38

Bumper length adder 0.25"

Bimba Position Feedback Cylinders Non-Contact

Bimba Non-Contact PFC Rod Lock

Bimba's non-contact Position Feedback Cylinders employ a new magnetostrictive sensor. The sensor tip, fixed inside the cylinder, senses position as a magnet mounted to the piston moves back and forth across the sensor tip's length. This provides many important advantages, and makes the Non Contact PFC the preferred solution for closed-loop pneumatic positioning applications

How to Order

The model number of all Non-Contact PFC Rod Lock Cylinders consists of three alpha-numeric clusters. These designate product type, bore size, stroke length, mounting style, and options. The example below describes PFCNL-703-XB-YQ, a non-contact

Position Feedback Cylinder with 3 inch bore, 3 inch stroke, universal mount, bumpers, and low friction seals, and matched PCS controller with an enclosure and quick connects.

PFCNL - 70 3 - X B - YQ

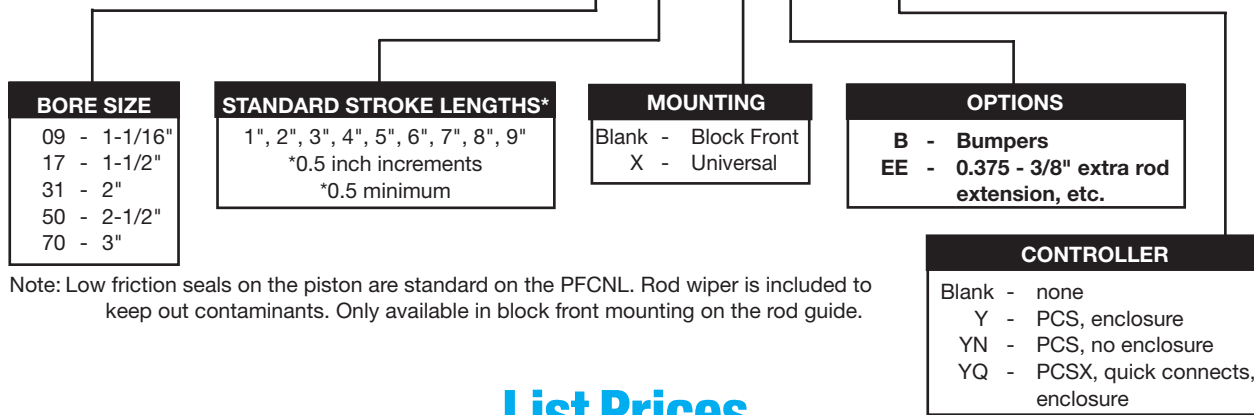

Note: Low friction seals on the piston are standard on the PFCNL. Rod wiper is included to keep out contaminants. Only available in block front mounting on the rod guide.

List Prices

Bore	Base	Stroke Adder (per inch)	Mounting	Options		Controller		
			X Universal	B Bumpers	EE Extra Extention (per inch)	*Y	*YN	*YQ
1-1/16" (09)	\$550.00	\$15.30	\$4.90	\$4.40	\$2.85	\$510.00	\$540.00	\$600.00
1-1/2" (17)	598.00	18.35	5.75	5.35	7.00			
2" (31)	665.00	21.25	7.20	6.90	9.30			
2-1/2" (50)	772.00	24.25	9.05	8.65	12.00			
3" (70)	874.00	27.40	12.00	13.00	12.00			

*Use Bimba PCS Controls for best results (options Y, YN, YQ).

Dimensions*

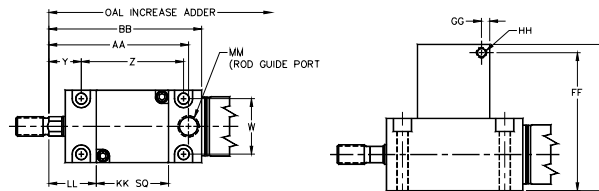

Bore	W	Y	Z	AA	BB	FF	GG	HH	JJ	KK	LL	MM	OAL Increase Adder
1-1/16" (09)	1.06	0.62	1.95	2.66	2.91	2.62	0.16	#10-32	2.78	1.38	0.90	1/8 NPT	1.08
1-1/2" (17)	1.25	0.64	2.75	3.36	3.68	3.13	0.25	1/8 NPT	3.38	1.75	1.14	1/4 NPT	1.68
2" (31)	1.62	0.82	3.13	3.97	4.34	4.20	0.38	1/8 NPT	4.45	2.25	1.26	1/4 NPT	1.94
2-1/2" (50)	1.88	0.87	3.62	4.62	5.05	5.34	0.33	1/4 NPT	5.67	2.75	1.31	3/8 NPT	2.33
3" (70)	2.25	0.90	4.17	5.17	5.59	5.86	0.50	1/4 NPT	6.28	3.25	1.35	3/8 NPT	2.69

*All other dimensions are same as the non-contact PFCN cylinders.

Bimba Position Feedback Cylinders

How it Works

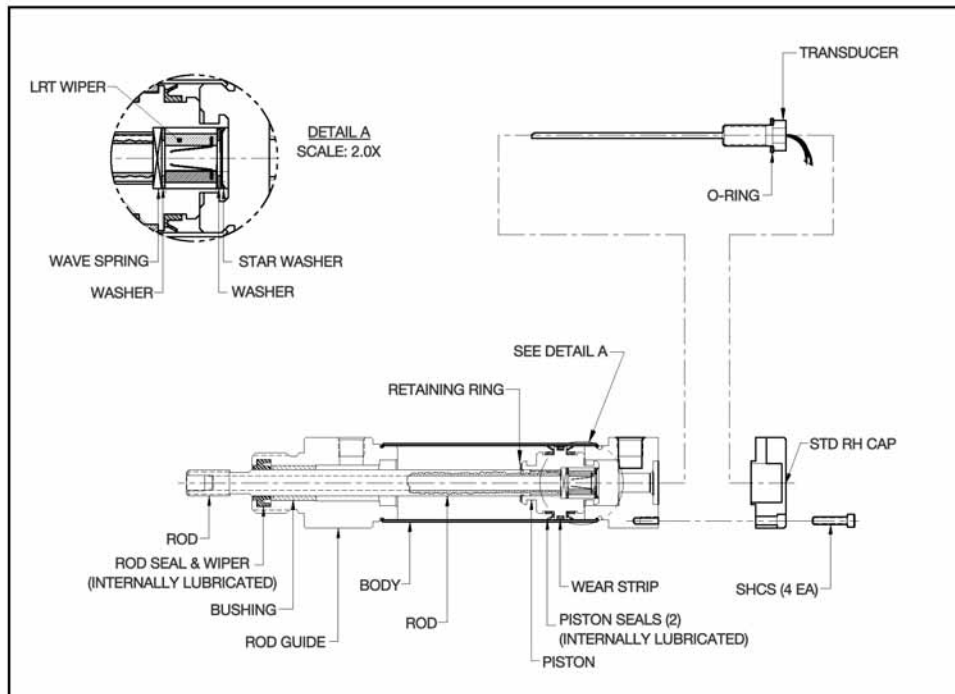

The *Bimba Position Feedback Cylinder* contains a Linear Resistive Transducer (LRT) or potentiometer mounted in the cylinder rear head. The LRT probe, which has a resistive element on one side and a collector strip on the other, is inside the cylinder rod. A wiper assembly is installed in the piston. As the piston moves, an electrical circuit is created between the resistive element and collector strip. A variable resistance (approximately 1K Ω per inch of stroke) proportional to piston position in the cylinder is produced by the cylinder. Consult www.bimba.com/techctr/techcenter.htm for a table of nominal resistance values at full extend and full retract for various strokes and options.

The cylinder can be easily setup to produce an analog signal compatible with 0-10 VDC PLC analog inputs.

The accuracy of an LRT is determined by three factors: resolution, linearity and repeatability.

Resolution refers to the smallest change that can be detected on the LRT. The Bimba LRT has infinite resolution, and can be divided into as many parts as the electronics allow. For example, with a 12-bit, 4096-part controller, the stroke could be divided into 4096 parts. When 10 VDC are placed on a 10" cylinder, the smallest detectable increment would be $10 \text{ VDC} \div 4096 = 2.4 \text{ millivolts}$ or 0.0024". Resolution is stroke sensitive, i.e., the longer the stroke, the less resolution.

Linearity refers to the maximum deviation of the output voltage to a straight line. The Bimba LRT's linearity is ± 1 percent of stroke.

Repeatability is the ability of the LRT to provide the same output voltage relative to a unique cylinder position each time the cylinder is cycled. Mechanical repeatability of the Bimba Position Feedback Cylinder is ± 0.001 ".

Bimba Position Feedback Cylinders

The Bimba Position Feedback Cylinder provides continuous position sensing in a lightweight, small-bore air cylinder.

Ideal for applications where magnetic position sensing is impractical, where variations in cylinder speed or stroke are needed, or where an operation requires constant monitoring of cylinder position.

How to Order

The model number of all Position Feedback Cylinders consists of three alphanumeric clusters. These designate product type, bore size, stroke length, and mounting style and options. The

example below describes PFC-0912-BFL-Y, a Position Feedback Cylinder with 1-1/16 inch bore, 12 inch stroke, block front mounting, low friction option, and a matching encased PCS controller.

PFC - 09 12 - BFL - Y

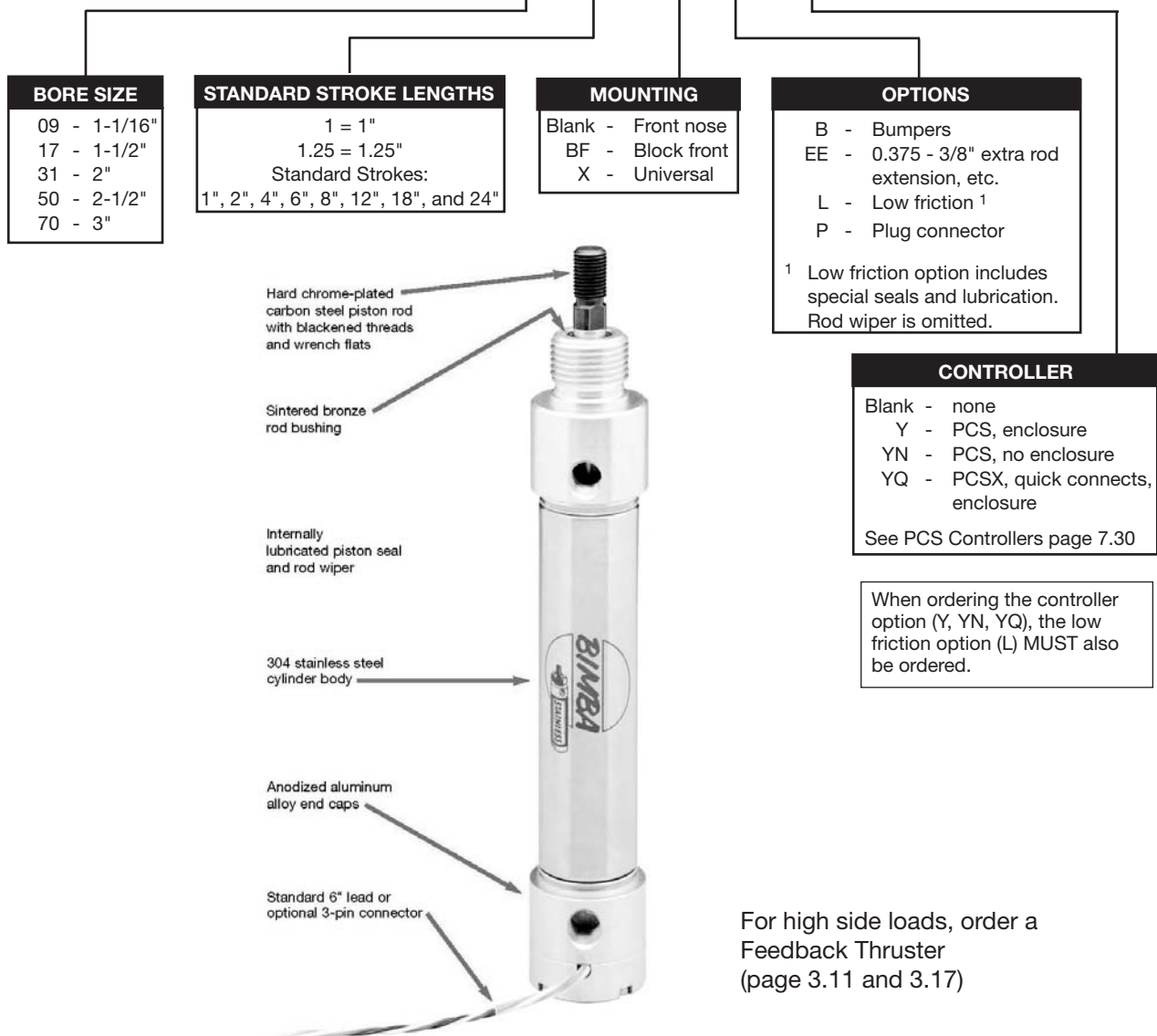

For high side loads, order a Feedback Thruster (page 3.11 and 3.17)

Bimba Position Feedback Cylinders

List Prices

Bore	Base	Stroke Adder (per inch)	Mounting		Options				*Controller		
			BF Block Front	X Universal	B Bumpers	EE Extra Extension (per inch)	L* Low Friction	P** Plug Connectors	*Y	*YN	*YQ
1-1/16" (09)	\$291.30	\$15.30	\$17.70	\$4.90	\$4.40	\$2.85	\$13.00	\$40.80	\$510.00	\$540.00	\$600.00
1-1/2" (17)	305.10	18.35	19.05	5.75	5.35	7.00	13.00	40.80			
2" (31)	329.80	21.25	23.10	7.20	6.90	9.30	13.00	40.80			
2-1/2" (50)	354.50	24.25	27.90	9.05	8.65	12.00	13.00	40.80			
3" (70)	380.60	27.40	35.80	12.00	13.00	12.00	13.00	40.80			

*Use Bimba PCS Controls for best results (options Y, YN, YQ).

Accessories

Bore	Mounting Nut	Mounting Bracket	Rod Clevis	Pivot Bracket
1-1/16" (09)	D-2545	D-8316	D-8310-A	D-8322-A
1-1/2" (17)	D-8484	D-8318	D-8311-A	D-8324-A
2" (31)	D-508	D-8319	D-8313-A	D-8325-A
2-1/2" (50)	D-2540	D-8320	D-8314-A	D-8326-A
3" (70)	D-5379	D-19127	D-8314-A	D-8326-A

See Original Line section for Accessory prices.

Control Units

- PCS closed loop position control systems are described on pages 7.29 through 7.39. Please use the table on page 7.35 to select the right PCS control for your PFC cylinder.
- DPM meters, ideal for measuring and gauging, are described on pages 7.42 through 7.47
- Electronic analog open loops controls are described on pages 7.48 through 7.50.

Cables (for connection to standard plug connector)

Model	Description	Price
C4-S	Straight Female Shielded Cord Set IP67, 2m	\$28.95
C4X-S	Straight Female Shielded Cord Set IP67, 5m	44.85
C5-S	Right Angle Female Shielded Cord Set IP67, 2m	28.95
C5X-S	Right Angle Female Shielded Cord Set IP67, 5m	44.85

Bimba Position Feedback Cylinders

Nose Mount

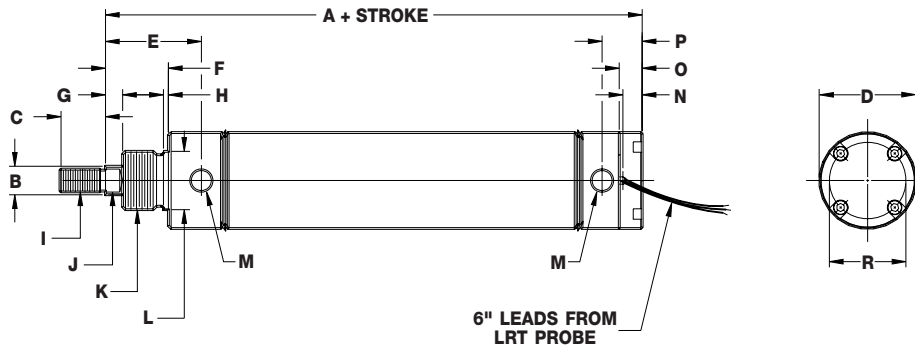

Universal Mount (for stud or pivot). Includes bushing.

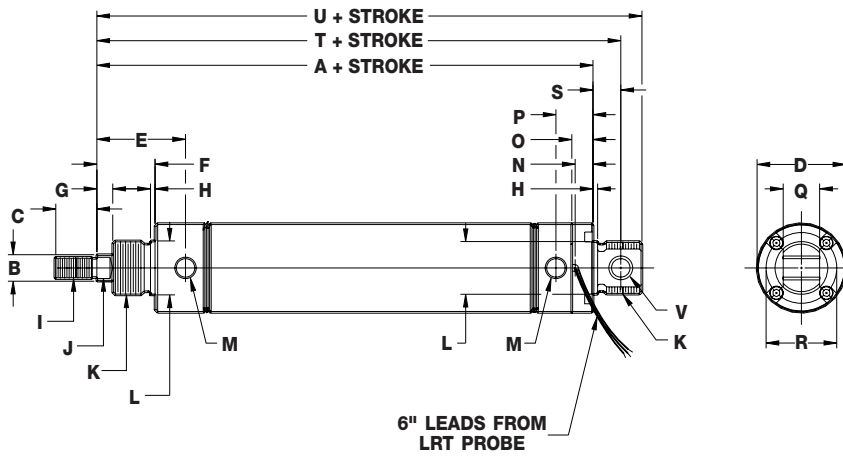

Block Mount

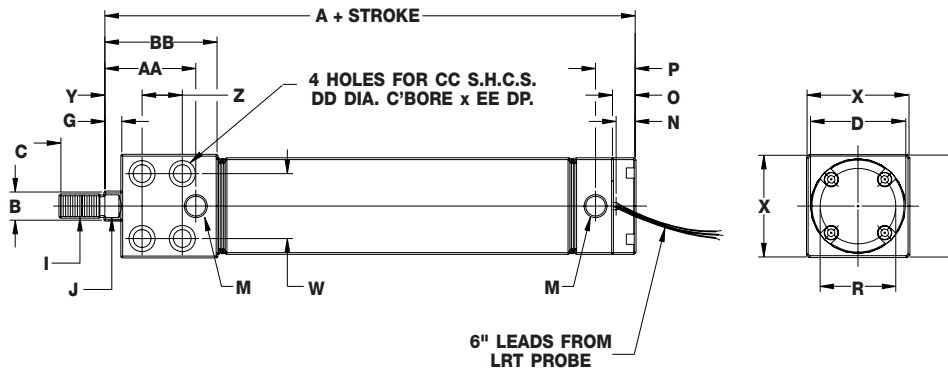

Note: Mounting holes farthest from rod end are omitted for -L option for 11/16" bore.

Position Feedback
Cylinders

Position Feedback
Cylinder Non Contact

Position Feedback
Cylinder Rod Lock

Position Feedback
Cylinder Accessories

Position Feedback
Pneu-Turn

Position
Control System

Digital Panel Meter

Electronic Controller

PLC/PCS/PTF
Application Checklist

Bimba Position Feedback Cylinders

Dimensions (in.)

	1-1/16" Bore (09)		1-1/2" Bore (17)	2" Bore (31)	2-1/2" Bore (50)	3" Bore (70)
A	4.59		4.88	5.72	6.41	6.78
B	Ø 0.38		Ø 0.50	Ø 0.63	Ø 0.75	Ø 0.75
C	0.63		0.88	1.00	1.25	1.25
D	Ø 1.31		Ø 1.58	Ø 2.09	Ø 2.58	Ø 3.13
E	1.75	Option L 1.52	1.72	2.10	2.28	2.53
F	1.06		1.13	1.38	1.50	1.69
G	0.31		0.31	0.38	0.44	0.44
H	0.08		0.09	0.11	0.13	0.13
I	3/8-24 UNF		7/16-20 UNF	1/2-20 UNF	5/8-18 UNF	5/8-18 UNF
J	0.31		0.44	0.50	0.63	0.63
K	7/8-14 UNF		1-1/8-12 UNF	1-1/4-12 UNF	1-3/8-12 UNF	1-1/2-12 UNF
L	Ø 0.87		Ø 1.12	Ø 1.25	Ø 1.37	Ø 1.62
M	1/8 NPT		1/4 NPT	1/4 NPT	3/8 NPT	3/8 NPT
N	0.36		0.36	0.42	0.48	0.55
O	0.44		0.44	0.50	0.56	0.63
P	0.84		0.81	0.88	1.12	1.88
Q	0.62		0.74	0.86	0.99	0.99
R	Ø 1.09		Ø 1.36	Ø 1.67	Ø 2.06	Ø 2.44
S	0.47		0.56	0.66	0.75	0.81
T	5.06		5.44	6.38	7.16	7.60
U	5.44		5.91	6.88	7.78	8.22
V	Ø 0.31		Ø 0.38	Ø 0.44	Ø 0.50	Ø 0.50
W	0.88		1.25	1.44	1.88	2.25
X	1.38		1.75	2.25	2.75	3.25
Y	0.75		0.69	0.75	0.88	0.94
Z	0.88		0.75	1.00	1.25	1.38
AA	1.63	Option L 1.52	1.68	1.75	2.13	2.31
BB	2.03		2.00	2.41	2.72	2.91
CC	#10		1/4	3/8	7/16	1/2
DD	Ø 0.33		Ø 0.41	Ø 0.58	Ø 0.67	Ø 0.77
EE	0.20		0.25	0.39	0.45	0.52

Bumper Length Adder: 0.25"

Bimba Position Feedback Cylinder Rod Lock

How to Order



The model number of all Position Feedback Cylinder Rod Lock actuators consists of three alphanumeric clusters. These designate product type, bore size and stroke length, and mounting style and options. The example below describes PFCL-0912-XPYN, a Position Feedback Rod Lock Cylinder with 1-1/16 inch bore, 12 inch stroke, plug connector, low friction seals, and a matching PCS controller with no enclosure.

PFCL - 09 12 - X B - YN

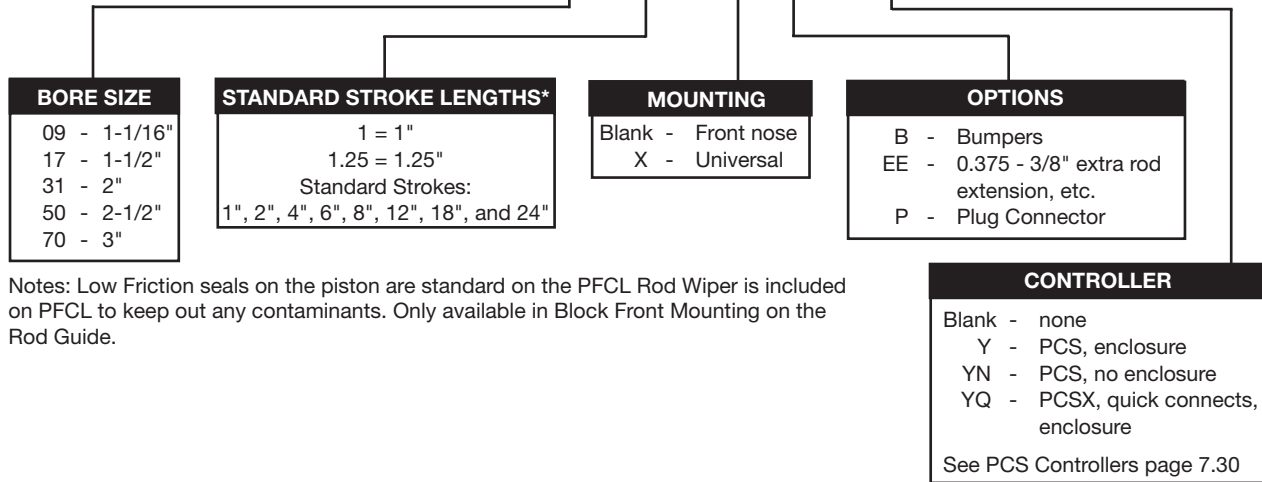

Notes: Low Friction seals on the piston are standard on the PFCL Rod Wiper is included on PFCL to keep out any contaminants. Only available in Block Front Mounting on the Rod Guide.

List Prices

Bore	Base	Stroke Adder (per inch)	Mounting		Options			Controller		
			X Universal	B Bumpers	EE Extra Extension (per inch)	P Plug Connector	*Y	*YN	*YQ	
1-1/16" (09)	\$376.20	\$15.30	\$4.90	\$4.40	\$2.85	\$40.80	\$510.00	\$540.00	\$600.00	
1-1/2" (17)	405.00	18.35	5.75	5.35	7.00	40.80				
2" (31)	455.20	21.25	7.20	6.90	9.30	40.80				
2-1/2" (50)	541.50	24.25	9.05	8.65	12.00	40.80				
3" (70)	617.30	27.40	12.00	13.00	12.00	40.80				

*Use Bimba PCS Controls for best results (options Y, YN, YQ).

Dimensions*

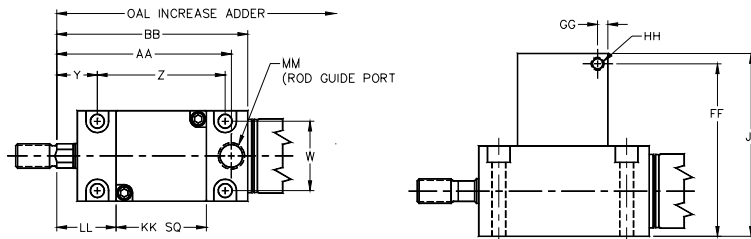

Bore	W	Y	Z	AA	BB	FF	GG	HH	JJ	KK	LL	MM	OAL Increase Adder
1-1/16" (09)	1.06	0.62	1.95	2.66	2.91	2.62	0.16	#10-32	2.78	1.38	0.90	1/8 NPT	1.08
1-1/2" (17)	1.25	0.64	2.75	3.36	3.68	3.13	0.25	1/8 NPT	3.38	1.75	1.14	1/4 NPT	1.68
2" (31)	1.62	0.82	3.13	3.97	4.34	4.20	0.38	1/8 NPT	4.45	2.25	1.26	1/4 NPT	1.94
2-1/2" (50)	1.88	0.87	3.62	4.62	5.05	5.34	0.33	1/4 NPT	5.67	2.75	1.31	3/8 NPT	2.33
3" (70)	2.25	0.90	4.17	5.17	5.59	5.86	0.50	1/4 NPT	6.28	3.25	1.35	3/8 NPT	2.69

*All other dimensions are same as the non-contact PFCN cylinders.

Bimba Position Feedback Cylinder Rod Lock

How it Works

- Dowel pins ride in the cam groove.
- When air pressure is present, piston actuates and dowel pins follow cam to open position, allowing piston rod to travel freely through clamp.
- In absence of pressure, the spring actuates piston and dowels follow to closed position, activating the rod clamp.

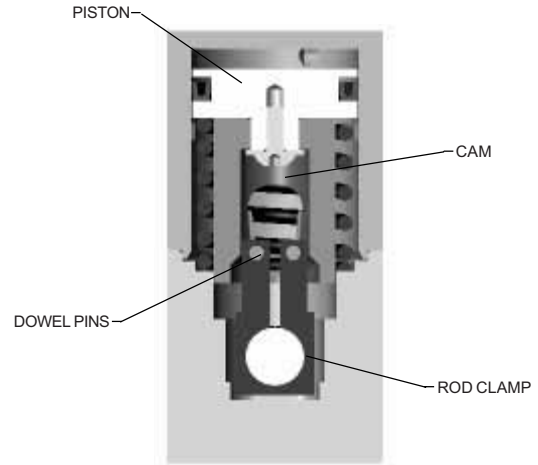
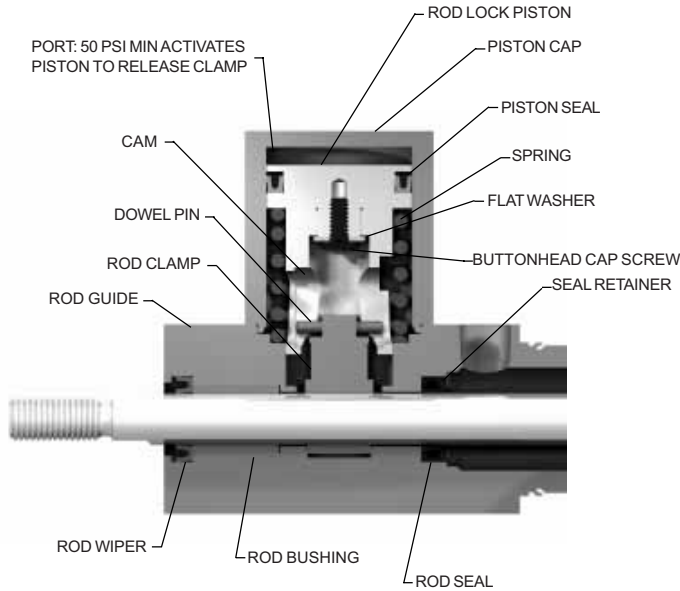
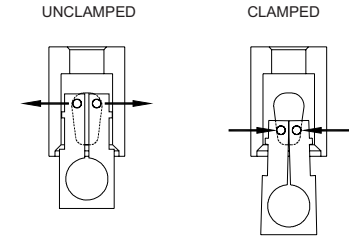

Engineering Specifications*

Operating Medium:	Air
Operating Pressure:	50psi minimum (to actuate lock piston) 125psi maximum
Temperature Range:	-20 to +200 degrees F
Lubrication:	HT-99
Cylinder Body:	304 stainless steel
Rod Guide:	Aluminum
Cap:	Anodized aluminum
Piston and Rod Seal:	Buna-N
Rod and Pivot Bushing:	Sintered bronze
Piston Rod:	Hard chrome plated carbon steel
Expected Service Life:	5 million cylinder actuations 1 million lock actuations

*PFC specifications are on page 7.15.

Rod Lock Holding Forces

Bore	Holding Force (Pounds)
3/4" (04)	40
1-1/16" (09)	90
1-1/2" (17)	170
2" (31)	310
2-1/2" (50)	500
3" (70)	700

Operating Guidelines/Product Precautions

- The Rod Lock is not a safety device.
- Do not use for intermediate stopping; the cylinder is designed to prevent drift from a stationary position.
- Load weight must not exceed the stated holding force for the cylinder.
- Do not release rod lock if full pressure is present on either extend or retract. Uncontrolled motion will result that could damage internal components or cause personal harm.

Bimba Position Feedback Cylinder Accessories

Options

3-pin Connector

Wire Colors

WIRES	6" LEADS	PLUG
Input	Red	Blue
Ground	Black	Black
Output	White	Brown

Dimensions (in.)

Bore	N
09	0.25
17	0.25
31	0.31
50	0.38
70	0.44

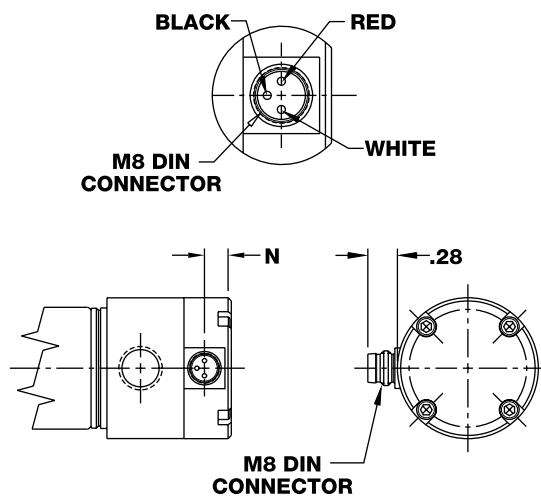

Straight-Models C4-S (2m), C4X-S (5m).

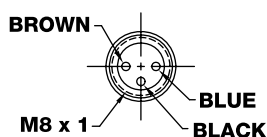
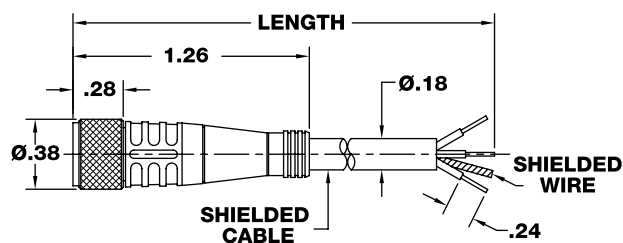

Right Angle-Models C5 (2m), C5X (5m)

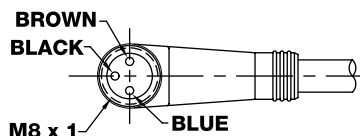
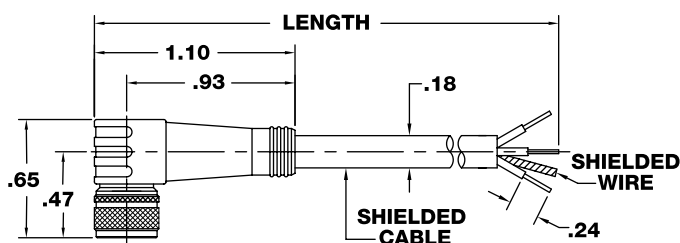

Cable: 24 AWG PVC insulated, fine stranded copper conductors, with Gray PVC jacket

Bimba Position Feedback Cylinder Accessories

Accessories (in.)

Mounting Nuts



Model D-2540

**Models D-2545
D-8484
D-508
D-5379**

Bore	Model	A	B	C	D	E
1-1/16" (09)	D-2545	1.31	0.48	7/8-14 UNF-2B	N/A	N/A
1-1/2" (17)	D-8484	1.69	0.61	1-1/8-12 UNF-2B	N/A	N/A
2" (31)	D-508	1.88	0.50	1-1/4-12 UNF-2B	1.81	0.03
2-1/2" (50)	D-2540	1.88	0.50	1-3/8-12 UNF-2B	1.81	0.03
3" (70)	D-5379	2.25	0.50	1-1/2-12 UNF-2B	2.25	0.02

Mounting Bracket

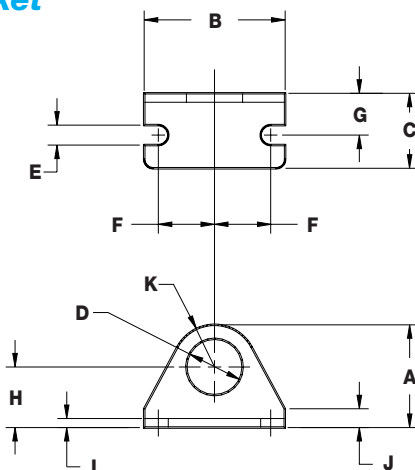

Bore	Model	A	B	C	D	E	F	G	H	I	J
1-1/16" (09)	D-8316	1.75	2.12	1.16	0.875	0.28	0.78	0.66	1.00	0.16	0.32
1-1/2" (17)	D-8318	2.19	2.75	1.44	1.125	0.34	1.06	0.81	1.25	0.19	0.38
2" (31)	D-8319	2.44	3.00	1.59	1.25	0.34	1.19	0.91	1.38	0.22	0.44
2-1/2" (50)	D-8320	2.81	3.75	1.88	1.312	0.41	1.50	1.06	1.62	0.25	0.50
3" (70)	D-19127	3.14	4.38	1.62	1.625	0.34	1.75	1.00	1.89	0.25	0.89

Bimba Position Feedback Cylinder Accessories

Accessories (in.)

Rod Clevis

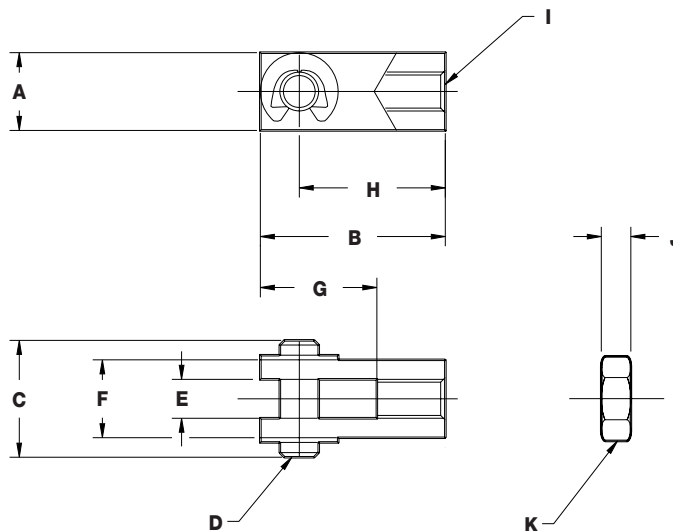

Bore	Model	A	B	C	D	E	F	G	H	I	J	K
1-1/16" (09)	D-8310-A	0.62	1.69	0.88	0.312	0.31	0.62	0.94	1.38	3/8-24 THD	0.22	3/8-24 HEX NUT
1-1/2" (17)	D-8311-A	0.75	2.00	1.03	0.375	0.38	0.75	1.12	1.62	7/16-20 THD	0.25	7/16-20 HEX NUT
2" (31)	D-8313-A	0.88	2.31	1.14	0.438	0.44	0.88	1.31	1.88	1/2-20 THD	0.31	1/2-20 HEX NUT
2-1/2" (50) & 3" (70)	D-8314-A	1.00	2.75	1.38	0.50	0.50	1.00	1.50	2.25	5/8-18 THD	0.38	5/8-18 HEX NUT

Pivot Bracket

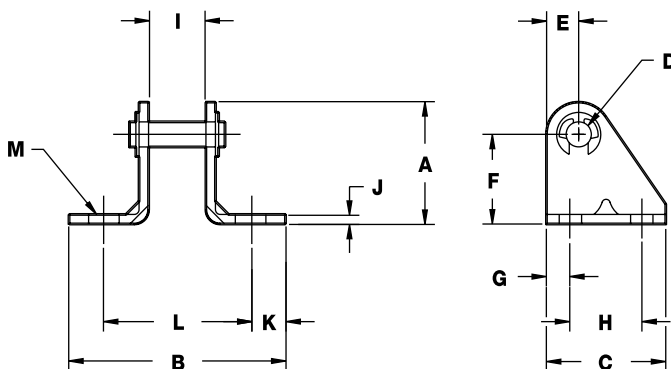

Bore	Model	A	B	C	D	E	F	G	H	I	J	K	L	M
1-1/16" (09)	D-8322-A	1.31	2.38	1.31	0.312	0.31	1.00	0.25	0.81	0.62	0.16	0.31	1.75	0.28
1-1/2" (17)	D-8324-A	1.62	3.00	1.62	0.375	0.38	1.25	0.31	1.00	0.75	0.19	0.44	2.13	0.34
2" (31)	D-8325-A	1.81	3.25	1.81	0.438	0.44	1.38	0.31	1.19	0.88	0.25	0.44	2.38	0.34
2-1/2" (50) & 3" (70)	D-8326-A	2.12	4.00	2.12	0.50	0.50	1.62	0.38	1.38	1.00	0.25	0.62	2.75	0.41

Bimba Position Feedback Cylinder Accessories

Engineering Specifications

Repeatability:	±0.001" Cylinder Only. <i>Refer to specifications in the following sections for positioning or measuring repeatability. Power supply ripple and A/D error may reduce repeatability when PFC is utilized with industrial control systems.</i>
Nonlinearity:	± 1 percent of full stroke
Resolution:	Infinite
Signal Input:	10 VDC typical
Input Impedance Required:	1 MOhm
Signal Output:	> 0 to slightly less than FS signal input <i>(The internal electrical stroke is slightly larger than the mechanical stroke of cylinder)</i>
Maximum speed:	25 in./sec.
Rated Life of LRT Wiper:	1,000 ¹ miles of travel
Rated Life of Probe:	10 million cycles ¹
Air Requirements:	Filtered to 5 micron with 0 degree dewpoint recommended. Moisture inside cylinder will cause output signal fluctuation.
Pressure Rating:	150 psi
Temperature Rating:	0° to 200°F ²
Interface:	6" standard leads or optional 8mm DIN connector
Cylinder Body:	304 stainless steel
Piston Rod:	Hard chrome plated carbon steel with blackened threads and wrench flats
Rod Bushing:	Sintered bronze
End Caps:	Anodized Aluminum alloy
Piston Seal:	Internally lubricated urethane (standard) Internally lubricated Buna (L option)
Rod Wiper:	Internally lubricated Buna N (omitted on L option)
Rod Seal:	Internally lubricated Buna N (N/A on standard model)

¹Higher velocities increase wear rate.

²Special low temperature lubrication is required for positioning applications using option L seals below 35°F.

ESTIMATED CYLINDER WEIGHTS (LBS)					
	1-1/16"	1-1/2"	2	2-1/2"	3
PFC-	0.44	0.88	2.02	2.78	3.62
PFC-X	0.49	0.96	2.14	2.96	3.85
PFC-BF	0.54	1.07	2.28	3.02	4.08
ADDER WT/IN	0.06	0.10	0.15	0.20	0.29

Repair Parts

PART	DESCRIPTION
RPFC-Bore Stroke-Options*	Replacement Cylinder
RD-53129-Stroke-Options**	Replacement Probe

* Only options required are BF, B, and L as Rear Cap is not included.

** Only option required for replacement probe is Option P.

How to Order

Add the bore size, stroke and options needed to the basic model number shown above for a replacement cylinder.

Add the stroke length to the basic model number shown above for a replacement probe. For example, a replacement probe for a 6" stroke Position Feedback Cylinder would be ordered as a RD-53129-6.

LRT CIRCUIT DIAGRAM

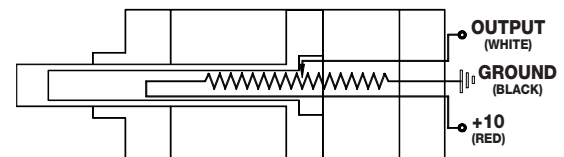

STROKE = 0; OUTPUT VOLTAGE = 0 VOLTS
STROKE = FULL; OUTPUT VOLTAGE = 10 VOL

Bimba Position Feedback Pneu-Turn

How it Works

Pneu-Turn® Position Feedback Rotary Actuator - Model PTF

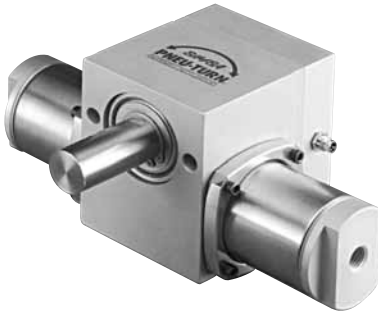

The Bimba Pneu-Turn® position feedback rotary actuator (PTF) provides continuous shaft position sensing. Standard features include shaft ball bearings and the elimination of mid-rotational backlash. Use the Bimba PTF in conjunction with Bimba's Pneumatic Control System (PCS) to achieve rotary shaft positioning accuracy within $\pm 0.5^\circ$.

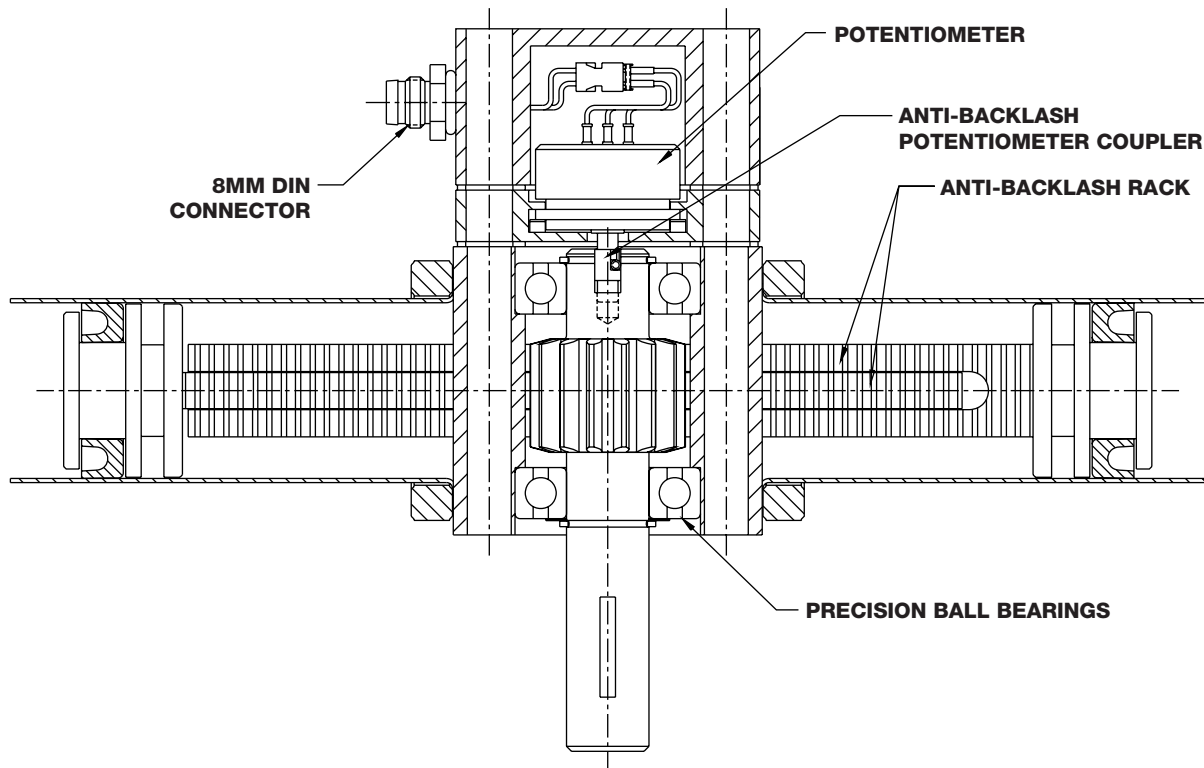

Position Feedback
Cylinders

Position Feedback
Cylinder Non Contact

Position Feedback
Cylinder Rod Lock

Position Feedback
Cylinder Accessories

Position Feedback
Pneu-Turn

Position
Control System

Digital Panel Meter

Electronic Controller

PF/PCS/PTF
Application Checklist

Bimba Position Feedback Pneu-Turn

How to Order

The model number of the Pneu-Turn rotary actuator with shaft position feedback capabilities consist of three alphanumeric clusters. These designate product type, series, angle of rotation, and special options. Please refer to the charts below for an

example of model number PTF-098180-A1H1YN, a 1-1/2" bore, single rack, 180° angle of rotation actuator with angle adjustment on both sides, plug connector located on the clockwise side, and a matching PCS control with no enclosure.

PTF-098 180 - A1H1 - YN

SERIES - TORQUE FACTOR
098 - 1-1/2" Bore, Single Rack
196 - 1-1/2" Bore, Double Rack
247 - 2" Bore, Single Rack
494 - 2" Bore, Double Rack

PTF base units include ball bearing and anti-backlash options.

To determine theoretical output torque (in-lbs.), place a decimal point between the first and second digits of the series number. Then multiply that number by the air line pressure for the approximate torque produced.

For example, a PT-098 will produce an output torque of .98 times the air line pressure.

STANDARD ANGLE OF ROTATION
045 - 45°
090 - 90°
180 - 180°
325 - 325°

Larger rotational angles are available. Contact your Bimba distributor.

OPTIONS
A1 - Angle adjustment, both sides
A2 - Angle adjustment, counterclockwise rotation
A3 - Angle adjustment, clockwise rotation
B1 - Bumpers, both sides
B2 - Bumpers, counterclockwise rotation
B3 - Bumpers, clockwise rotation
C1 - Cushion, both sides ¹
C2 - Cushion, counterclockwise rotation ¹
C3 - Cushion, clockwise rotation ¹
G - Magnalube® G lubrication
H1 - Plug connector, clockwise side
H2 - Plug connector, back of plate
H3 - Plug connector, bottom of plate
K - Square key
M - MRS® magnetic position sensing
S - Seals, oil service ²
V - High temperature option (0°F to 250°F) ³

¹ Cushions will reduce positioning accuracy.

² Oil service not recommended for applications at pressures less than 40 psi.

³ Ball bearing units with high temperature option is 0°F to 250°F.

® Magnalube is a registered trademark of Carleton Stuart Corporation.

CONTROLLER
Blank - none
Y - PCS, enclosure
YN - PCS, no enclosure
YQ - PCSX, quick connects, enclosure

See PCS Controllers page 7.30

Bimba Position Feedback Pneu-Turn

Option Combination Availability

Due to design or compatibility restrictions, the following options may **not** be ordered in combination. For example, C (Cushions) and B (Bumpers) are not available in combination.

Option Series	A	B	C	K	M	S	V
1-1/2" (098)	N/A	C,S	B,S	N/A	V	B,C	M
1-1/2" (196)	N/A	C,S	B,S	N/A	V	B,C	M
2" (247)	N/A	C,S	B,S	N/A	V	B,C	M
2" (494)	N/A	C,S	B,S	N/A	V	B,C	M

Note: Temperature range of ball bearing units with high temperature option is 0°F to +250°F.

List Prices

Bore Size and Type	1-1/2"		2"	
	Single (098)	Double (196)	Single (247)	Double (494)
Base Price	\$591.30	\$742.40	\$701.00	\$918.40
Adder per 45° Rotation	9.00	17.90	15.10	30.10
Angle Adjustment (A1, A2, A3)	\$12.90 per end		\$15.90 per end	
Bumper (B1, B2, B3)	5.70 per end		6.40 per end	
Cushion (C1, C2, C3)	13.10 per end		16.40 per end	
Square Key (K)	2.30		3.40	
MRS (M)	15.10		27.70	
Oil Service Seals (S)	20.30		23.20	
High Temperature Option (V) Single Rack	13.50		15.10	
High Temperature Option (V) Double Rack	26.90		30.10	
AV Combination	1.40 per end plus A and V adders		1.70 per end plus A and V adders	
BV Combination	.90 per end plus B and V adders		1.40 per end plus B and V adders	
CV Combination	1.60 per end plus C and V adders		1.90 per end plus C and V adders	
SV Combination	21.50 per end plus S and V adders		24.60 per end plus S and V adders	
Y	510.00		510.00	
YN	540.00		540.00	
YQ	600.00		600.00	

No charge options - G, H1, H2, H3.

Cables

Model	Description	Price
C4-S	Straight female cordset, 2m, IP67, shielded	\$28.95
C4X-S	Straight female cordset, 5m, IP67, shielded	44.85
C5-S	Right angle female cordset, 2m, IP67, shielded	28.95
C5X-S	Right angle female cordset, 5m, IP67, shielded	44.85

Bimba Position Feedback Pneu-Turn

Single Rack Models (in.)

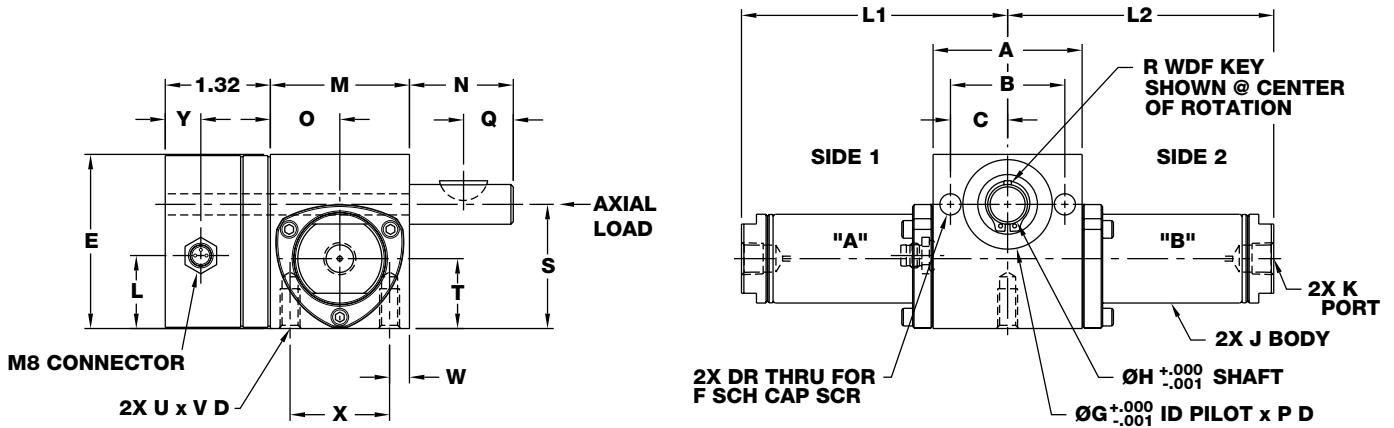

Plug connector shown in standard position. The H1 option dimensionally positions the connector on the clockwise rotation side.

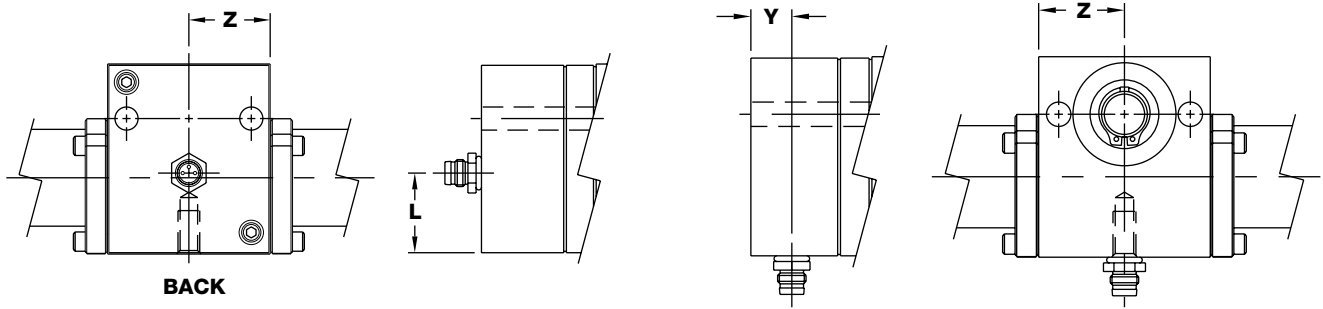

Bore	A	B	C	E	F	G (Ball Bearing I.D. Pilot)	H	J	K	L	M
1-1/2" (098)	2.38	1.81	0.90	2.84	5/16" S.H.C.S.	1.375	0.625	1.56	1/8 NPT	1.449	2.25
2" (247)	3.00	2.38	1.19	3.75	5/16" S.H.C.S.	1.875	0.875	2.08	1/4 NPT	1.918	2.56

Bore	N	O	P	Q	R	S	T	U	V	W	X	Y	Z
1-1/2" (098)	1.38	1.12	0.09	0.62	#405	2.09	1.15	5/16-18	0.62	0.31	1.62	0.45	1.19
2" (247)	2.00	1.28	0.10	0.75	#606	2.56	1.28	5/16-18	0.62	0.28	2.00	0.45	1.50

Bimba Position Feedback Pneu-Turn

Double Rack Models (in.)

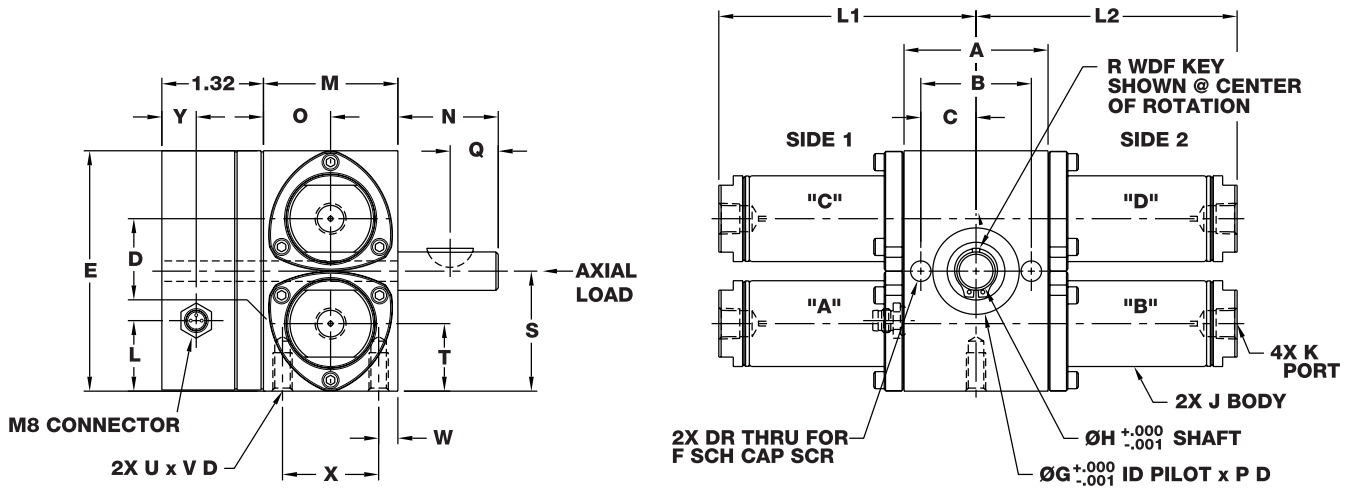

Plug connector shown in standard position. The H1 option dimensionally positions the connector on the clockwise rotation side.

H2 Option

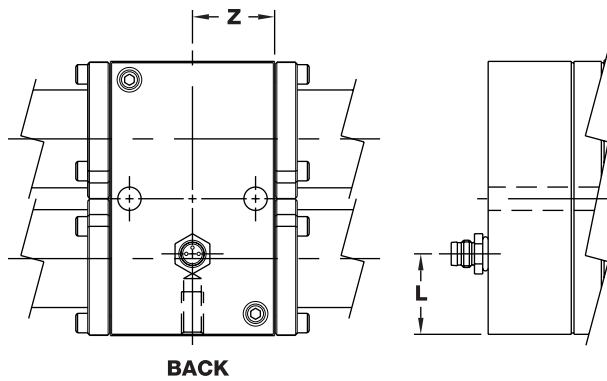

H3 Option

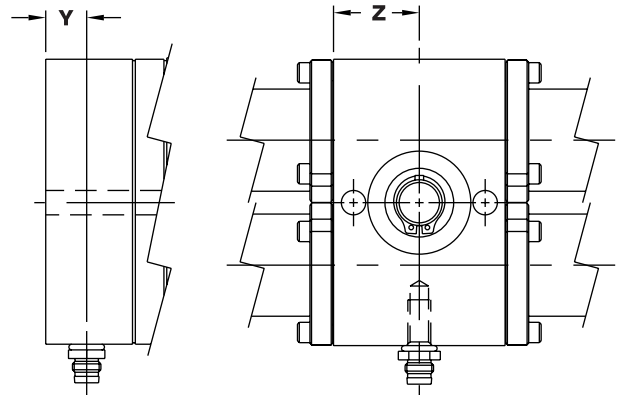

Bore	A	B	C	D	E	F	G (Ball Bearing I.D. Pilot)	H	J	K	L	M
1-1/2" (196)	2.38	1.81	0.90	1.88	4.19	5/16" S.H.C.S.	1.375	0.625	1.56	1/8 NPT	1.449	2.25
2" (494)	3.00	2.38	1.19	2.56	5.13	5/16" S.H.C.S.	1.875	0.875	2.08	1/4 NPT	1.918	2.56

Bore	N	O	P	Q	R	S	T	U	V	W	X	Y	Z
1-1/2" (196)	1.38	1.12	0.09	0.62	#405	2.09	1.15	5/16-18	0.62	0.31	1.62	0.45	1.19
2" (494)	2.00	1.28	0.10	0.75	#606	2.56	1.28	5/16-18	0.62	0.28	2.00	0.45	1.50

Bimba Position Feedback Pneu-Turn

Single Rack Options (in.)

(Dimensional variations from standard as shown)

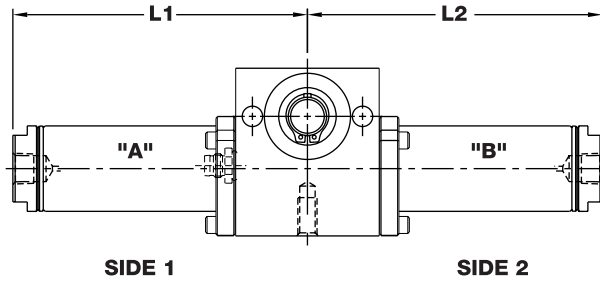

	1-1/2" (098)		2" (247)	
	L1	L2	L1	L2
Adder per Degree of Rotation	0.0097	0.0097	0.0137	0.0137
Base Unit (No Options)	2.34	2.34	2.84	2.84
Bumper Both Sides (B1)	2.49	2.49	3.04	3.04
Bumper CCW Side (B2)	2.34	2.49	2.84	3.04
Bumper CW Side (B3)	2.49	2.34	3.04	2.84
Cushion Both Sides (C1)	2.98	2.98	3.65	3.65
Cushion CCW Side (C2)	2.34	2.98	2.84	3.65
Cushion CW Side (C3)	2.98	2.34	3.65	2.84
Oil Service Seals (S)	2.77	2.77	3.38	3.38
Oil Service with Angle Adjustment (AS)	3.41	3.41	4.19	4.19

Double Rack Options (in.)

(Dimensional variations from standard as shown)

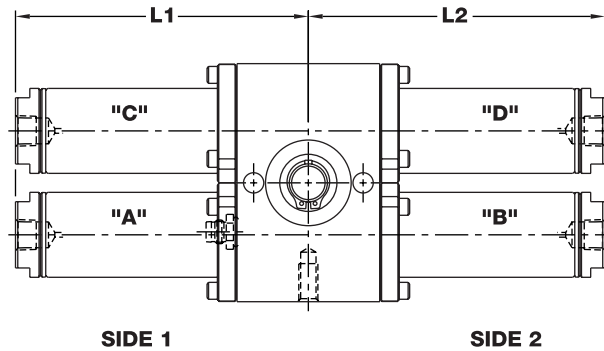

	1-1/2" (098)		2" (247)	
	L1	L2	L1	L2
Adder per Degree of Rotation	0.0097	0.0097	0.0137	0.0137
Base Unit (No Options)	2.34	2.39	2.84	2.89
Bumper Both Sides (B1)	2.49	2.39	3.04	2.89
Bumper CCW Side (B2)	2.49	2.39	3.04	2.89
Bumper CW Side (B3)	2.49	2.39	3.04	2.89
Cushion Both Sides (C1)	2.98	2.39	3.65	2.89
Cushion CCW Side (C2)	2.98	2.39	3.65	2.89
Cushion CW Side (C3)	2.98	2.39	3.65	2.89
Oil Service Seals (S)	2.77	2.39	3.38	2.89
Oil Service with Angle Adjustment (AS)	3.41	2.39	4.19	2.89

"CCW Side" –

refers to the extreme rotation of the shaft in the counter-clockwise direction as viewed from the mounting pilot side of the actuator.

The location of the optional feature chosen will be on tube B for single rack models and tube C for double rack models.

"CW Side" –

refers to the extreme rotation of the shaft in the clockwise direction as viewed from the mounting pilot side of the actuator.

The location of the optional feature chosen will be on tube A for both single and double rack models.

Bimba Position Feedback Pneu-Turn

Options

MRS® Magnetic Position Sensing

Magnetic pistons are located on the A and B tubes of both the single and double rack rotary actuators, guaranteeing switch operation at any point in the rotation.

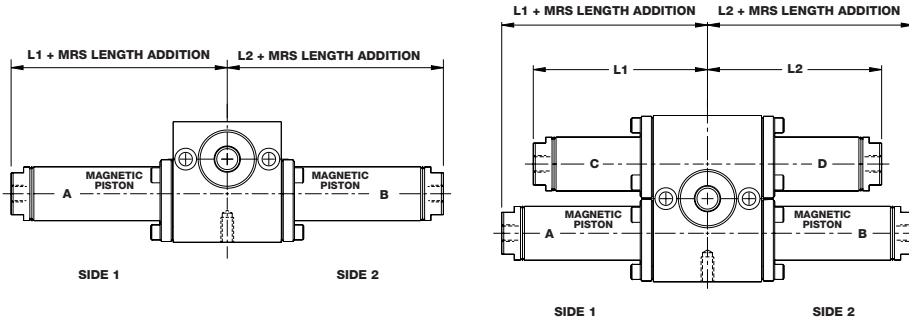

MRS® Length Adder (in.)

Degrees	098/196	247/494
45°	0.75	0.75
90°	0.53	0.44
180°	0.09	0.00
325°	0.00	0.00

Woodruff Key (in.)

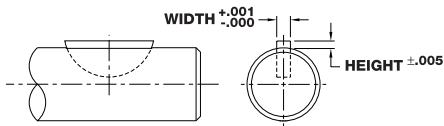

Key No.	Width	Height
405	0.1250	0.063
606	0.1875	0.094

Square Key (in.)

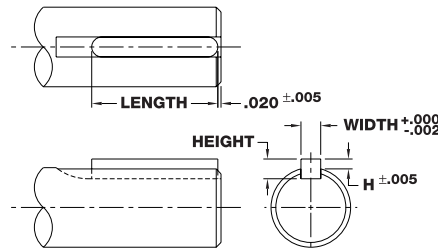

Bore Size	Length	Width	Height	H
1-1/2" (098/196)	0.797	0.188	0.188	0.094
2" (247/494)	1.781	0.250	0.250	0.125

Option Dimensions

Cushion (C Option) (in.)

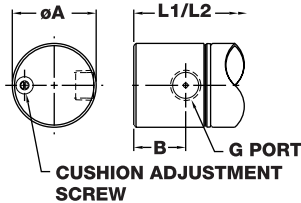

Angle Adjustment with Oil Service Seals (AS Option) (in.)

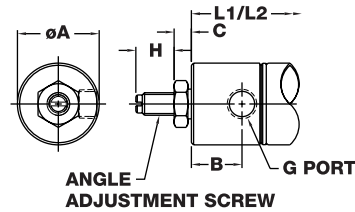

Angle Adjustment with Cushion (AC Option) (in.)

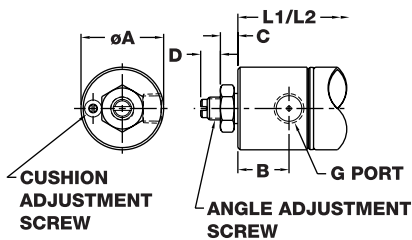

Angle Adjustment (A Option) (in.)

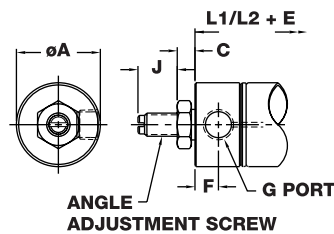

Bore	A	B	C	D	E	F	G	H	J
1-1/2" 098 and 196	1.56	0.77	0.27	0.33	0.42	0.34	1/8 NPT	0.67	0.67
2" 247 and 494	2.08	0.87	0.31	0.49	0.53	0.41	1/4 NPT	0.97	0.97

Bimba Position Feedback Pneu-Turn

Repair Parts

Single Rack Model

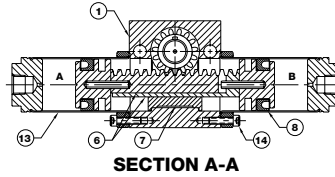
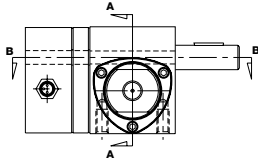

Ball Bearing® Option

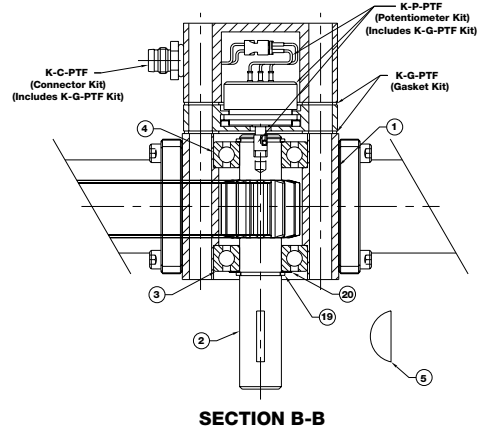

Double Rack Model

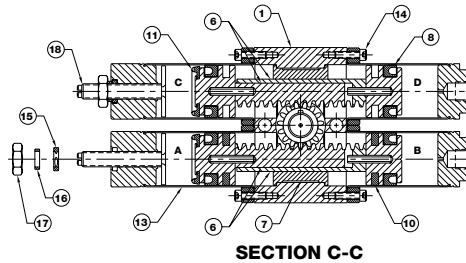
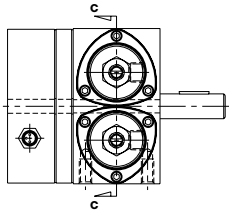

Repair Parts

No.	Part Description	Quantity Required	
		Single	Double
PT-1-R	Actuator Body	1	1
PTF-2	Shaft/Pinion Assembly	1	1
PT-3-R	Front Shaft Ball Bearing	1	1
PT-4-R	Rear Shaft Ball Bearing	1	1
PT-5	Shaft Key	1	1
PT-7-X	Rack Support	1	2
PTF-8	Piston Seal ¹	2	4
PT-9	Piston Wear Ring (Required for Oil Service only)	2	2
PT-10	Magnet	2	2
PT-11	Bumper	2	2
PT-13	Cylinder Body Assembly (Includes Body, End Cap, and Retainer Ring)	2	4
PT-14	Cylinder Body Retainer Cap Screw ²	6	12
PT-15	Cylinder Body Thread Seal	2	2
PT-16	Cylinder Body Thread Seal Ring	2	2
PT-17	Cylinder Body Jam Nut	2	2
PT-18	Angle Adjustment Screw	2	2
PT-19	Retaining Ring	2	2
PT-20	Shim Package	1	1

¹ Double Rack Models require two repair kits per rotary actuator. Oil Service Option: Single Rack models require four oil service seals or two oil service seal kits. Double Rack models require four oil service seals and two standard seals or two oil service seal kits and one standard seal kit.

² 2" bore requires 8 or 16.

Repair Kits

Bearing Kit (K-A-PT-R)		
PT-3-R	Front Shaft Ball Bearing	1
PT-4-R	Rear Shaft Ball Bearing	1

Shaft Kit (K-S-PTF)		
PTF-2	Shaft/Pinion Assembly	1
PT-5	Shaft Key	1

Seal Kit (K-L-PTF)		
PTF-8	Piston Seals	2

Gasket Kit (K-G-PTF)		
Gasket		1

Connector Kit (K-C-PTF)		
Connector Assy.		1
Gasket		2

Potentiometer Kit (K-P-PTF)		
Pin Header		1
Potentiometer Assy.		1
Potentiometer Coupler		1
Gasket		2

Bimba Position Feedback Pneu-Turn

Engineering Specifications

Repeatability:	± 0.01° (of potentiometer itself)
Nonlinearity:	± .88° (± 0.25% of 340±4°)
Resolution:	Infinite
Signal Input:	10 VDC typical
Input Impedance Required:	100 Kohm
Signal Output:	0 to 10 VDC FS (depends on FS mechanical rotation)
Rated Life of Potentiometer:	10 million cycles
Temperature Coefficient:	± 600 ppm/°C
Electrical Rotation:	340° ±4°

General Specifications

Rotary action of the Pneu-Turn rotary actuator is achieved through the use of a rack and pinion assembly. Just as with any hydraulic or pneumatic cylinder, the speed of rotation may be controlled through the use of flow controls. The PTF may also be controlled with Bimba's Pneumatic Control System, Model PCS.

Care should be taken to insure that the inertial force does not exceed the published torque capacity.

Port Positioning

Ports on the PTF may be repositioned to accommodate any air line configuration by loosening the three body retainer screws. Once desired port positions are obtained, screws must be tightened to specified torque values in the table below.

Lubrication

The PTF is prelubricated at the factory for extensive, maintenance free operation. The life of the rotary actuator can be lengthened by providing additional lubrication with an air line mist lubricator or direct introduction of the oil to the actuator every 500 hours of operation. Recommended oils for Buna N seals are medium to heavy inhibited hydraulic or general purpose oil.

The rack and pinion gear and ball bearings are prelubricated at the factory for extensive maintenance free operation. If additional lubrication is required, use a high grade bearing grease.

Woodruff Key Location

The standard position of the woodruff key is 12 o'clock at the center of rotation.

Ratings

Pressure Rating: 150 psi air or oil with S Option

Rotation Tolerance:

1-1/16" - 2" bore is -0° to +10°. The Angle Adjustment Option allows 45° of adjustability. If cushions are ordered in conjunction with the angle adjustment option, adjustability will be 10°.

Temperature Range: Standard Seals: -20° to 200° F; V Option High Temp seals: 0° to 250°.

Note: If used for positioning applications, it is recommended to use low temperature lubricant for temperatures less than 35°F.

Backlash: Both single and double rack models have zero mid-rotational and end of rotation backlash.

Breakaway: Less than 3 psi.

Series	1-1/2"		2"	
	(098)	(196)	(247)	(494)
Theoretical Torque Capacity (in-lbs/PSI)	0.982	1.963	2.468	4.935
Bearing Load (Axial lbs)	110	110	130	130
Bearing Load (Radial lbs)	425	425	740	740
Distance between bearing midpoints (in)	1.71	1.71	1.82	1.82
Maximum rate of rotation (@ 100 PSI with no load)	1500 deg/sec	1500 deg/sec	1000 deg/sec	1000 deg/sec
Weight (approximate oz)	47	88	103	150
Body Retainer cap screw recommended tightening torque (in-lbs)	20	20	20	20

Bimba Position Control System

Model PCS



The Bimba Position Control System (Model PCS) is designed to control any pneumatic Bimba position feedback actuator. This includes series PFCN, PFCNL, PFC, and PFCL for linear motion, and the Position Feedback Pneu-Turn (PTF) for rotary motion. The system is a closed-loop electronic controller with pneumatic valves that can accurately position the actuator rod or shaft and hold it in position with a high degree of accuracy and force. The system uses pneumatic technology to accurately stop and hold the rod or shaft at any desired position.

The standard PCS accepts a 0-10 V DC or 4-20 mA analog command signal (jumper selectable). The command signal is used as a reference to move to and hold a specific position. For example, if the application has a stroke of 10 inches (i.e., the electrical zero and span is set for a 10 inch stroke), then a 1 volt change in the command voltage is equal to a 1 inch movement. Similarly, a change in command signal of 0.005 of a volt equals a position change of 0.005 of an inch for the same 10 inch stroke application. If the application has a stroke of 5 inches, a change of 1 volt in the command signal represents a 1/2" inch movement. For rotary applications, the convention is similar. If the application has a rotation of 180 degrees, then a 1 volt change in the command signal is equal to 18 degrees of rotation.

The system utilizes the feedback from the actuator to close the control loop. The control loop compares the system's command signal (the 0-10 V DC or 4-20mA input command signal) to the feedback

signal from the actuator. The difference between the command and feedback is referred to as the error term. When the error term is zero, all valves close, trapping air on both sides of the actuator piston. (The error term is considered to be zero when it is within the deadband range. The deadband range is an adjustable range that determines the final repeatability of the system. The Application Sizing chart located in our Full Line Catalog shows recommended deadband ranges for given application parameters.) This holds the rod or shaft at its commanded position. If some force or weight attempts to move the rod or shaft out of the commanded position, the system will react by increasing the restoring force eventually to full supply pressure, if necessary. Likewise, if the command signal changes, the system will respond to make the feedback equal the command signal.

There are four adjustments on the PCS system, adjustable via four trim pots. They include the Zero, Span, Decel, and Deadband adjustments. The Zero and Span adjustments allow you to set the zero and full scale position of the actuator to match the input (command) signal. The Decel and Deadband adjustments are used to optimize the performance of the system based on application parameters. These adjustments are described in detail in the Operating Manual, which is included with each system.

The actual accuracy and repeatability of the movements will depend on many factors, including signal noise, load, velocity, supply pressure, supply voltage, and application friction.

Bimba Position Control System

How to Order

The model number for all Pneumatic Control Systems consist of three alpha numeric clusters. These designate product type, flow size, and options. Please refer to the charts below for an

example of model number PCS-1-Q. This is a system with a Cv of 0.02 and the Quick Connect connector option.

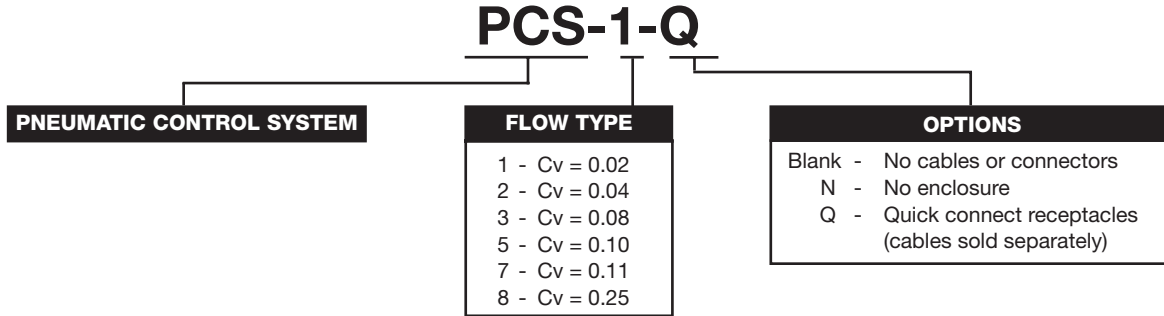

This initial offering covers 1-1/16" (09) through 2" (31) bore size Position Feedback Cylinders. Larger flow PCS Systems are available for the larger bore sizes Refer to TRD Position Control System Product Catalog or contact Bimba for further details. Refer to the Position Feedback Cylinder

section (page 7.6) and the Position Feedback Pneu-Turn section (page 7.17) for ordering information regarding either actuator. Ensure that the Position Feedback Cylinder -L option is specified for motion control applications.

*The Cv values are approximated. The velocities for the different systems are shown in the sizing recommendations table. Note: All PCS units can accept 0-10 VDC or 4-20 mA signals (jumper selectable).

List Prices

Model	Base	Options	
		N	Q
PCS-1	\$688.00	\$86.00	\$229.30
PCS-2	688.00	86.00	229.30
PCS-3	688.00	86.00	229.30
PCS-5	688.00	86.00	229.30
PCS-7	688.00	86.00	229.30
PCS-8	688.00	86.00	229.30

Accessories

Part Number	Description	Price
PCS-CBL-PWR	2 meter Power Cable for Quick Connect Option	\$32.70
PCS-CBL-PWR-X	5 meter Power Cable for Quick Connect Option	50.20
PCS-CBL-CMD	2 meter Command Signal Cable for Quick Connect Option	52.70
PCS-CBL-CMD-X	5 meter Command Signal Cable for Quick Connect Option	75.20
PCS-CBL-FBK	2 meter Feedback Cable for Quick Connect Option	62.75
PCS-CBL-FBK-X	5 meter Feedback Cable for Quick Connect Option	87.75

One power, command and feedback cable required if option Q is purchased.

Bimba Position Control System

Dimensions

Shown in inches (millimeters)

Enclosure

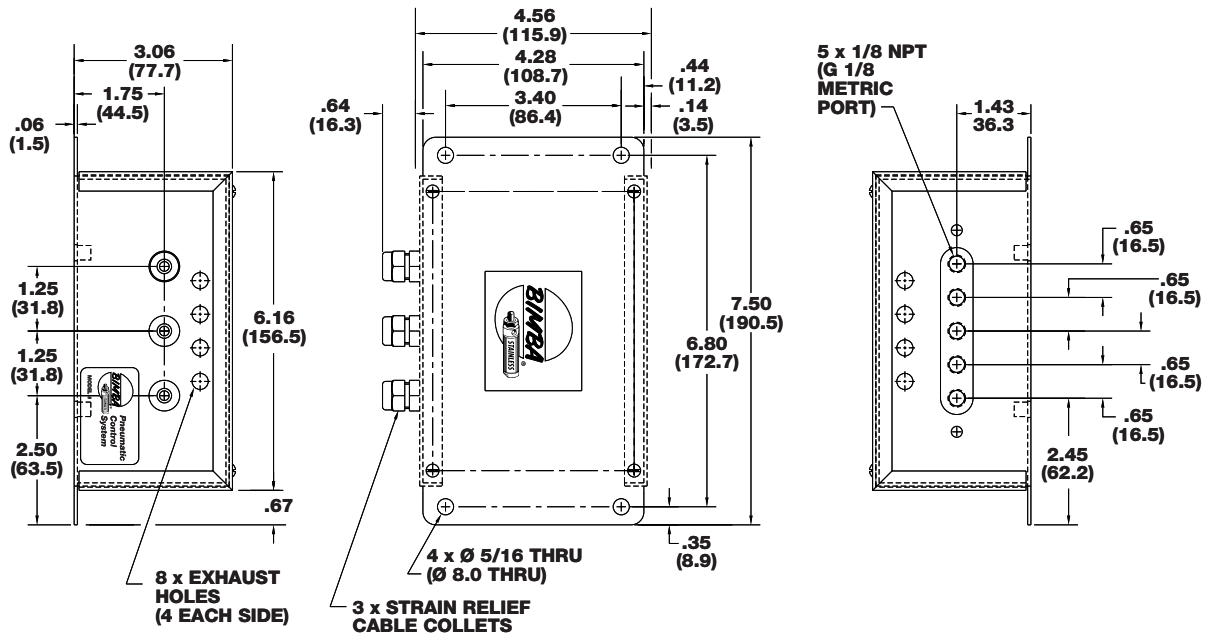

Option Q (Quick Connect Receptacle)

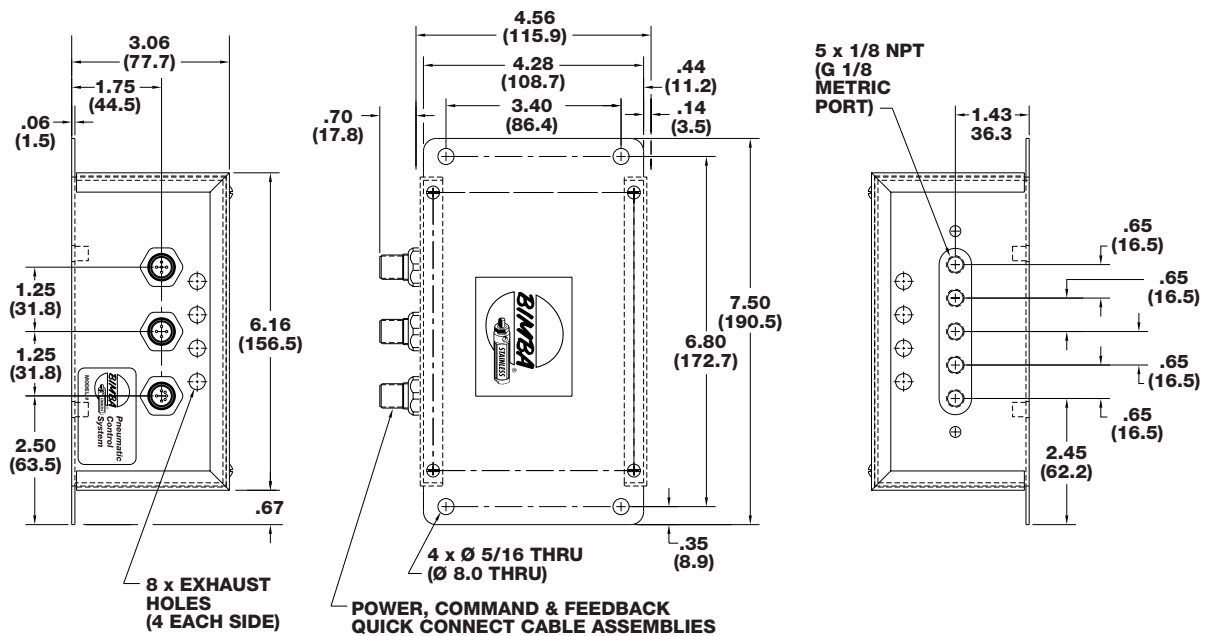

Bimba Position Control System

Dimensions

Shown in inches (millimeters)

Quick Connect Cables

PCS-CBL-PWR

SPECIFICATIONS
5 CONDUCTORS OF 22 AWG LEADS RATED TO 250 V AT 4 AMPS SHIELDED

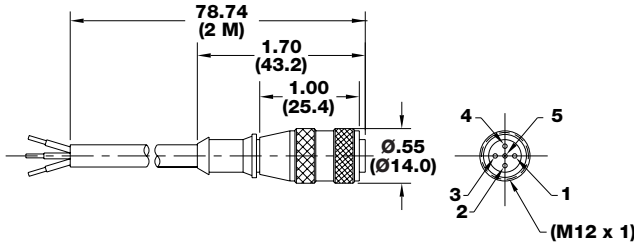

PCS-CBL-PWR-X

SPECIFICATIONS
5 CONDUCTORS OF 22 AWG LEADS RATED TO 250 V AT 4 AMPS SHIELDED

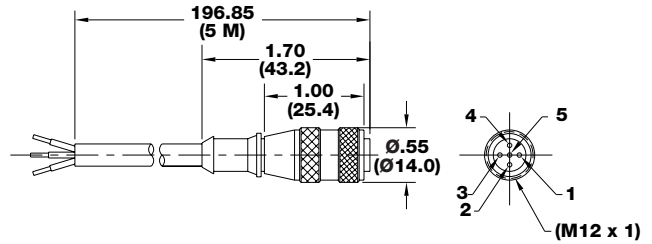

PCS-CBL-PWR Wire Color Codes

Color	Pin	Description
Brown	1	Positive
White	2	N/C
Blue	3	Negative
Black	4	N/C
Green/ Yellow	5	N/C

PCS-CBL-CMD Wire Color Codes

Color	Pin	Description
Brown	1	Input
White	2	@ Position
Blue	3	Ground
Black	4	Current Position
Grey	5	N/C
Pink	6	N/C

PCS-CBL-CMD

SPECIFICATIONS
6 CONDUCTORS OF 24 AWG LEADS RATED TO EITHER 30 VAC OR 36 VDC AT 4 AMPS SHIELDED

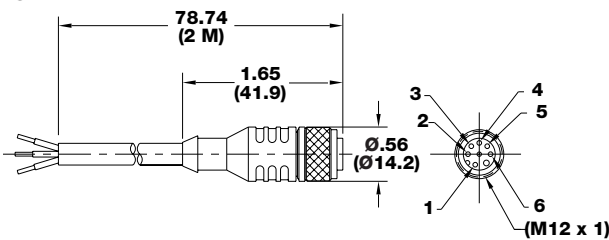

PCS-CBL-CMD-X

SPECIFICATIONS
6 CONDUCTORS OF 24 AWG LEADS RATED TO EITHER 30 VAC OR 36 VDC AT 4 AMPS SHIELDED

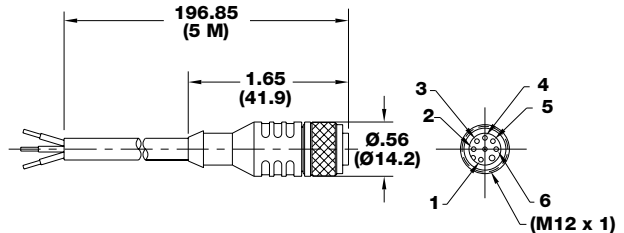

PCS-CBL-FBK

SPECIFICATIONS
3 CONDUCTORS OF 24 AWG LEADS RATED TO 120 V AT 4 AMPS SHIELDED

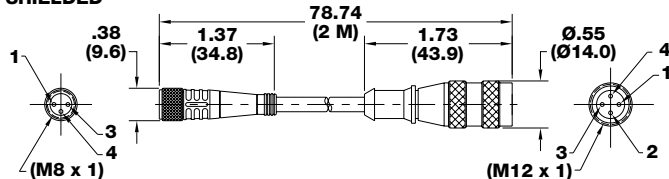

PCS-CBL-FBK-X

SPECIFICATIONS
3 CONDUCTORS OF 24 AWG LEADS RATED TO 120 V AT 4 AMPS SHIELDED

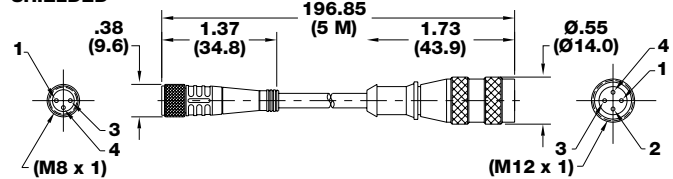

Bimba Position Control System

Dimensions

Shown in inches (millimeters)

Option N (No Enclosure)
PCS - 1, 2, 3

PC Board

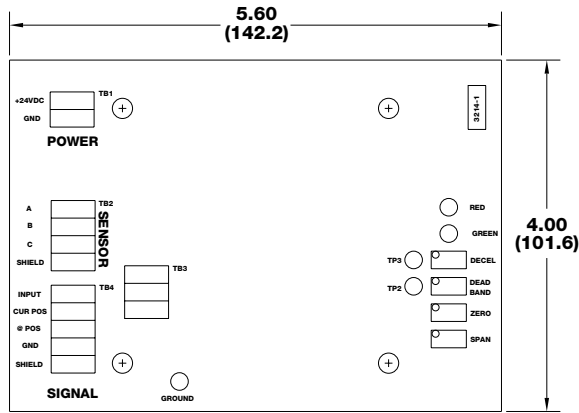

Snap Track

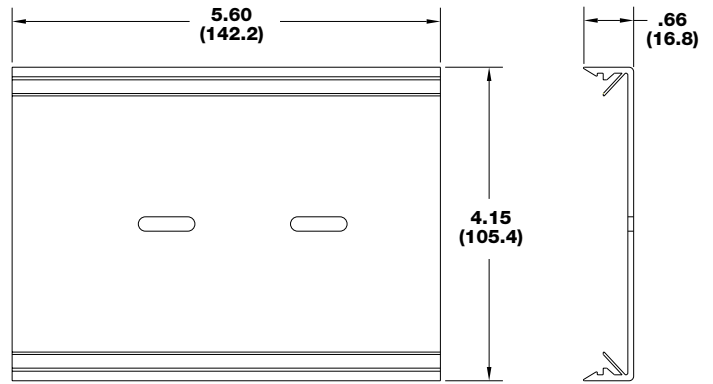

Valve/Manifold

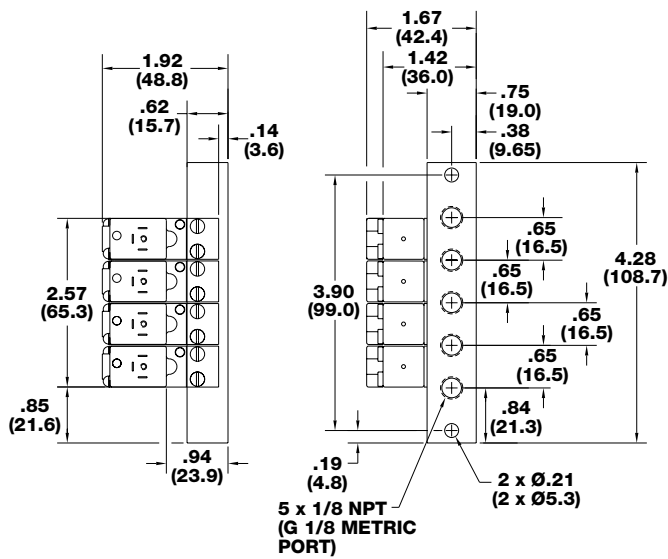

Valve Cable

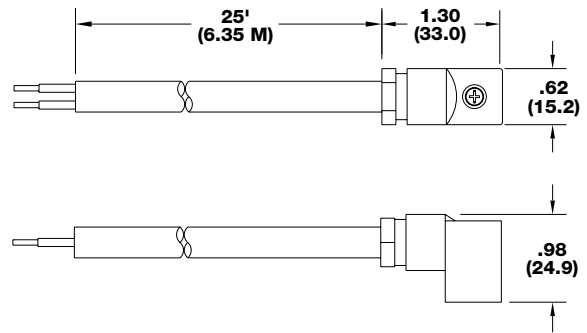

PCS - 4, 5, 6, 7

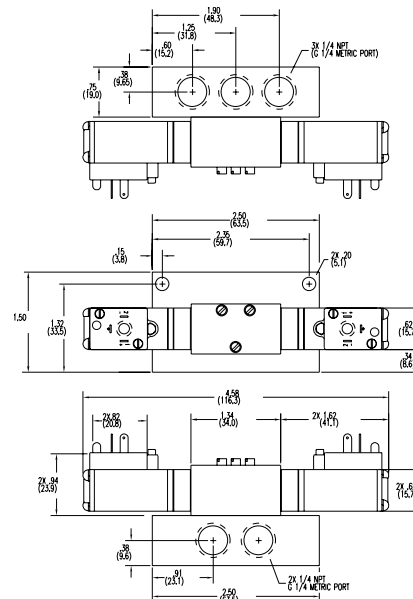

Bimba Position Control System

Specifications

Description	Specification
Zero Adjustment	50% of total full scale output between both adjustments
Span Adjustment	
DECEL Adjustment	Approximately 0.5 to 13.5 volts
Deadband Adjustment	Approximately 0.005 to 0.500 volts
@ Position	Discrete output that sinks to ground when within deadband zone. 20mA Maximum
Current Position	0 to 10 VDC signal, 1M ohm input impedance required for input device. Scaled with zero and span adjustments
Operation at Power Loss	All valves close at power loss
Input Supply Voltage	23.5 to 24.5 VDC, 1 amp
Operating Pressure	70 to 80 psig
Air Requirement	Regulated and filtered to 5 micron
Operational Temperature Range	0 to 100 degrees F (Electronics/PC Board)
Reverse Polarity Protected	
Overvoltage Protected	

Application Sizing and “Rules of Thumb”

PFC Cylinder/PCS Valve System Matching and Sizing Recommendations¹

Bore Size	PCS Model	Stroke Range	Maximum Payload @ Average Velocity (lbs.)	Maximum Average Velocity without overshoot (in/sec)	Maximum External Friction (lbs.)	Zero Friction Deadband Width per inch of stroke	1/2 Maximum Friction Deadband Width per inch of stroke	Maximum Friction Deadband Width per inch of stroke	Minimum Step (in.)
1-1/16" (PFC-09)	PCS-1	2" to 7"	1	2.75	0	0.005"	N/A	N/A	0.08
1-1/16" (PFC-09)	PCS-1	8" to 24"	30	4.00	5	0.004"	0.008"	0.016"	0.2-0.39
1-1/2" (PFC-17)	PCS-1	1" to 3"	2	2.50	0	0.0025"	N/A	N/A	0.04
1-1/2" (PFC-17)	PCS-2	4" to 24"	50	5.50	10	0.002"	0.004"	0.008"	2 times deadband
2" (PFC-31)	PCS-2	1" to 2"	4	2.75	0	0.005"	N/A	N/A	2 times deadband
2" (PFC-31)	PCS-3	3" to 24"	90	6.50	20	0.0015"	0.003"	0.006"	2 times deadband
2-1/2" (PFC-50)	PCS-5	3" to 24"	120	2.00	35	0.009"	0.006"	0.006"	2 times deadband
3" (PFC-70)	PCS-7	3" to 24"	200	2.00	50	0.004"	0.004"	0.006"	2 times deadband
3-1/4"	PCS-7	5" to 24"	235	2.00	60	0.004"	0.004"	0.006"	2 times deadband
4"	PCS-7	3" to 4"	360	2.00	90	0.008"	N/A	N/A	2 times deadband
4"	PCS-8	5" to 25"	360	2.00	90	0.004"	0.004"	0.006"	2 times deadband

¹ If your application requires lower velocities or payloads, you may be able to reduce the minimum recommended deadband setting, or if your deadband requirements can accommodate a large range, you may be able to increase your payload higher than the recommended values.

Bimba Position Control System

Application Sizing Cont.

Assumptions used for Sizing Values recommendations:

- Values shown in sizing table are with no overshoot. If overshoot is acceptable for your application, the deadband may possibly be less than specified. However, be sure your system cannot go unstable.
- PFC cylinder with Option L is used. (Option L has very low friction seals. The standard PFC utilizes a rod wiper which increases friction significantly, which will have adverse effects on positioning capabilities).
- 80 psi air supply.
- Minimum of 23.5 VDC provided to the PCS.
- Clean Command Signal for Main Control. (<5mV noise/ripple)
- Leak free system (The system will actually perform well with some system leakage, however, the best performance is with no leakage).
- Hard air lines (nylon) between the valves and the actuator.
- No backlash in the system.
- Horizontally guided load. The system can handle vertical or inclined loads and still meet the minimum deadband specified above, however, the velocity may be effected by up to 40%.
- Short air lines allow for better accuracy.

Typical "Rules of Thumb":

- Deviations from the recommended parameters, such as air pressure, power supply voltage, external friction, etc, will negatively effect system performance. However, the system may still perform adequately for your application.
- Applications with loads less than 10% of actuator capacity and strokes greater than 4 inches will yield better repeatability than the minimum deadband shown in the sizing table above.
- Reducing actuator velocity by use of Flow Controls may enable the deadband to be adjusted tighter for a given application. The Flow Controls must be inserted into the exhaust ports of the valve manifold, NOT in the actuator.
- Oversizing the actuator for a given application typically yields better repeatability.
- Generically, following are relative influences on velocity:
 - As Mass increases, Velocity decreases (up to 20%)
 - As Friction increases, Velocity decreases (up to 20%)
 - As Pressure decreases, Velocity decreases (up to 20%)
- Increased Friction decreases repeatability. Maximum external friction should not exceed 20% of the maximum rated payload. Any external friction in the application will degrade system performance. Ensure the system is aligned properly to any guiding systems. Misalignment will cause external application friction.
- A borderline solution can be effective through any/all of the following:
 - sacrificing performance in one area for another,
 - limiting velocity with external flow controls,
 - employing a small central portion of a longer probe,
 - using a larger bore cylinder.
- The PCS system is not suited for applications where accurate velocity control is needed by controlling the rate of command signal change. Flow controls can be used if lower velocities are required.



Do not allow the PCS valves to stay on for prolonged time periods unless the valves are well ventilated, as they may overheat potentially causing damage to the valves.

Application Sizing

PTF Cylinder and PCS Valve System Matching and Sizing Recommendations

Single Rack Model

PTF Single Rack Models Valve Sizing Recommendations						
Bore	Valve	Rotation	Minimal Deadband	Maximum Torque	Average Velocity	Minimum Step
1-1/2"	PCS-1	45° - 325°	28 mV	27 in.-lb.	150° per sec.	2 times deadband
2"	PCS-2	45° - 325°	28 mV	70 in. - lbs.	150° per sec.	2 times deadband

Double Rack Model

PTF Double Rack Models Valve Sizing Recommendations						
Bore	Valve	Rotation	Minimal Deadband	Maximum Torque	Average Velocity	Minimum Step
1-1/2"	PCS-2	45° - 325°	28 mV	55 in.-lb.	150° per sec.	2 times deadband
2"	PCS-3	45° - 325°	28 mV	135 in. - lbs.	150° per sec.	2 times deadband

If your application requires lower velocities or payloads, you may be able to reduce the minimum recommended deadband setting, or if your deadband requirements can accommodate a large range, you may be able to increase your payload higher than the recommended values.

**Testing was performed with an offset load in a vertical direction. Performance will improve with a balanced payload and the plane of motion is horizontal.

Deadband voltage conversion to shaft displacement

- The following formula can be used to convert the deadband voltage to displacement:

$w = 1/10V * t$, where w = deadband width, V = voltage reading from the PCS, t = full scale travel of the actuator (Note: for PTF rotary actuators with total rotation less than 180° always make $t = 180$)

Example: If the deadband is set for 30mV (0.03 of a volt) for a 180° actuator, the width of the deadband zone will be $1/10 * .028 * 180 = \pm 0.50^\circ$.

Specification Comments

- PTF Feedback signal 0 to 10 VDC only.
- Bearing Loads - Maximum Axial and Radial loads are identical to the standard Pneu-Turn with the ball bearing option.
- Maximum Allowable Kinetic Energy is identical to the standard Pneu-Turn with Cushions.
- Refer to the PCS New Product Bulletin for additional PTF performance information.

Bimba Position Control System

Application

Example

The following section will review two examples, one example shows a PFC application, and the second example shows a PTF rotary example.

PFC Example

Let's say we have just finished the installation procedure for a Bimba PFC Cylinder with 10 inches of stroke, and are using a 0-10 VDC input command signal. There is a retracted hard stop at 1.5 inches of cylinder stroke and an extended hard stop at the 9.0 inches of cylinder stroke.

Therefore:

- After adjusting the Span setting, 10 volts is equivalent to 9.0 inches of cylinder rod extension.
- After adjusting the Zero setting, 1.5 inches of cylinder rod extension will equal 0 volts.

Therefore, 0 to 10 volts covers the 7.5 inch (9.0" - 1.5") range of motion .

Using the following formula:

The command signal can be translated into actuator displacement with the following formula:

$$CS = d * R / t + Z$$

where:

- CS** = the command signal required to achieve a desired position
- d** = the displacement the desired position is from the zero position
- R** = the full range of the command signal
- t** = full scale travel of the actuator (Note: for PTF rotary actuators with total rotation less than 180° always make t = 180)
- Z** = the command signal for the zero position

Bimba Position Control System

Application

To command the PFC to go to a position that is 2.0 inches extended from the retracted hard stop, the command signal would be calculated as follows:

$$\text{CS} = 2 \times 10/7.5 + 0 = 2.667 \text{ VDC Command Input Signal}$$

If a 4-20 mA signal is used, the command input signal would be calculated as follows:

$$\text{CS} = 2 \times 16/7.5 + 4 = 8.267 \text{ mA Command Input Signal}$$

*Note: The positional repeatability of the system will be determined by the Deadband adjustment. If the deadband was adjusted to $\pm 20\text{mV}$ in this example, the system would position to the 2 inch position within $\pm 0.015"$ ($w = 0.1 (V) * t$).*

PTF Example

Let's say we have just finished the installation procedure for a Bimba PTF Rotary actuator with 200 degrees of rotation, and a 0-10 VDC command input signal. There is a zero rotational hard stop at 10 degrees of rotation and a full scale rotational hard stop at 190 degrees of rotation.

Therefore:

- After adjusting the Span setting, 10 volts is equivalent to 190 degrees of rotation.
- After adjusting the Zero setting, 10 degrees of rotation will equal 0 volts.

Therefore, 0 to 10 volts covers 180 degrees (190 - 10) of motion .

To command the actuator shaft to rotate to a position that is 45 degrees rotated from the zero hard stop, the command voltage would be calculated as follows:

$$\text{CS} = 45 \times 10/180 + 0 = 2.50 \text{ VDC Input Command Signal}$$

If a 4-20 mA input command signal is used, the command input would be calculated as follows:

$$\text{CS} = 45 \times 16/180 + 4 = 8 \text{ mA Command Input Signal}$$

*Note: The positional repeatability of the system will be determined by the Deadband adjustment. If the deadband was adjusted to $\pm 20\text{mV}$ in this example, the system would position to the 45 degree position within ± 0.36 degrees ($w = 0.1 (V) * t$).*

Position Feedback
Cylinders

Position Feedback
Cylinder Non Contact

Position Feedback
Cylinder Rod Lock

Position Feedback
Cylinder Accessories

Position Feedback
Pneu-Turn

Position
Control System

Digital Panel Meter

Electronic Controller

PFC/PCS/PTF
Application Checklist

Bimba Position Control System

PCS Repair Parts Breakdown

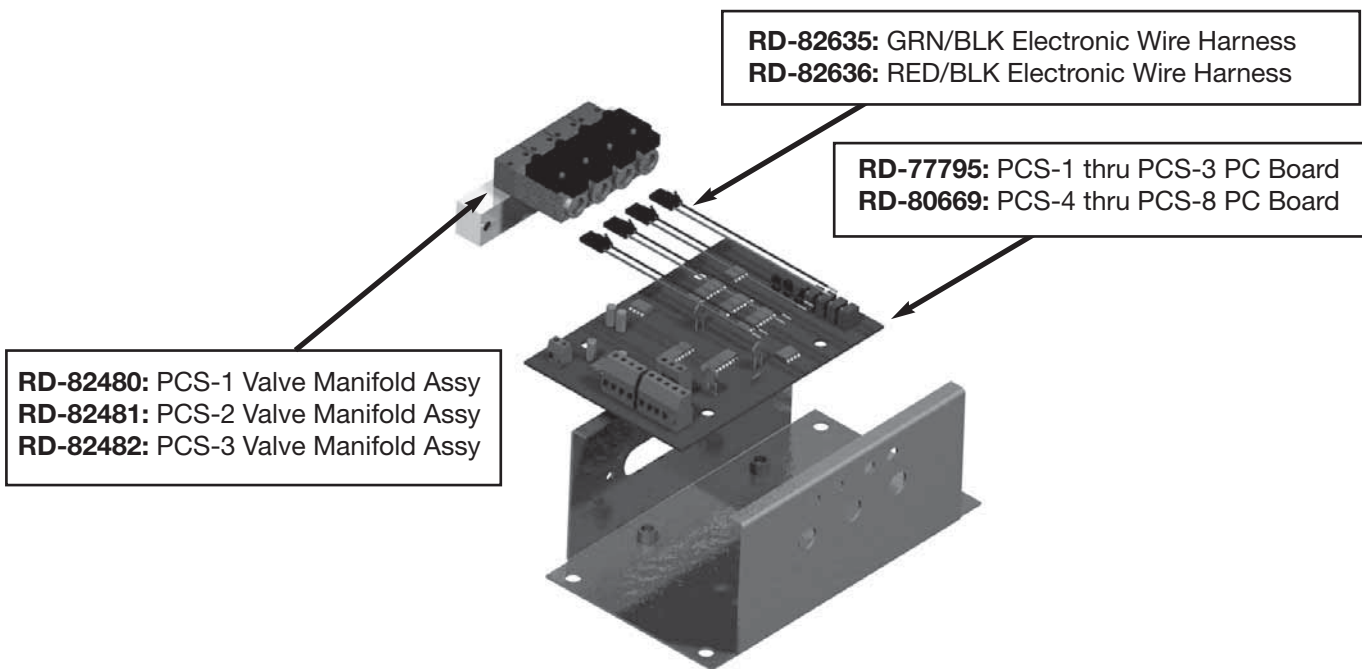

RD-82480: PCS-1 Valve Manifold Assy
RD-82481: PCS-2 Valve Manifold Assy
RD-82482: PCS-3 Valve Manifold Assy

RD-82635: GRN/BLK Electronic Wire Harness
RD-82636: RED/BLK Electronic Wire Harness

RD-77795: PCS-1 thru PCS-3 PC Board
RD-80669: PCS-4 thru PCS-8 PC Board

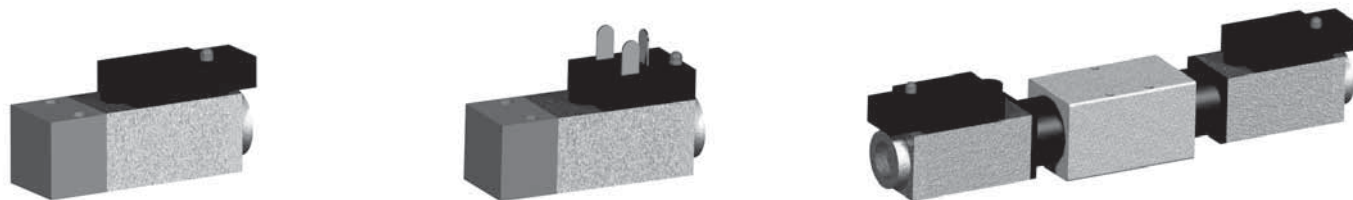

RD-78913: PCS-1 Std Valve
RD-78915: PCS-2 Std Valve
RD-78917: PDCS Std Valve

RD-78914: PCS-1 DIN Valve
RD-78916: PCS-2 DIN Valve
RD-78918: PDCS DIN Valve

RD-80670: PCS-4 Thru PCS-8 Std. Valve Assy

Note: The PCS-4 thru PCS-8 systems use the same valve, the difference is the orifice sizes in the manifold.

Bimba Position Control System

Repair Parts

Part Number	Description	List Price
RD-77795	PCS 1 thru 3 PC Board	\$564.10
RD-80262	PCS 1 thru 3 PC Board-Option C	570.40
RD-80669	PCS 4 thru 8 PC Board	564.10
RD-77296	500 Ohm Plug in Resistor for Option C	1.40
RD-77796	Snap Track for Option N	18.85
RD-77797	Option N Cable (each)	41.40
RD-82635	Grn/Blk Electronic Wire Harness	4.80
RD-82636	Red/Blk Electronic Wire Harness	4.80
RD-78913	PCS-1 Valve (Std Electronic Connector)	94.00
RD-78914	PCS-1 Valve (DIN Connector Option N)	112.80
RD-78915	PCS-2 Valve (Std Electronic Connector)	94.00
RD-78916	PCS-2 Valve (DIN Connector Option N)	112.80
RD-78917	PCS-3 Valve (Std Electronic Connector)	94.00
RD-78918	PCS-3 Valve (DIN Connector Option N)	112.80
RD-78919	PCS -1, -2, -3 Valve Mainfold**	94.00
RD-82480	PCS-1 Valve Manifold Assembly (Std)*	375.65
RD-82481	PCS-2 Valve Manifold Assembly (Std)*	375.65
RD-82482	PCS-3 Valve Manifold Assembly (Std)*	375.65
RD-77798	PCS-1 Valve Manifold Assembly (DIN)*	454.65
RD-77799	PCS-2 Valve Manifold Assembly (DIN)*	454.65
RD-77800	PCS-3 Valve Manifold Assembly (DIN)*	454.65
RD-80670	PCS-4 THRU 8 Valve (Electronic Connector)	470.90
RD-80671	PCS-4 THRU 8 Valve (DIN Connector)	489.70
RD-80672	PCS-4 Std. Manifold**	151.65
RD-80673	PCS-5 Std. Manifold**	151.65
RD-80674	PCS-6 Std. Manifold**	151.65
RD-80675	PCS-7 Std. Manifold**	151.65
RD-82634	PCS-8 Std. Manifold**	151.65
RD-80676	PCS-4 Manifold Option N	151.65
RD-80677	PCS-5 Manifold Option N	151.65
RD-80678	PCS-6 Manifold Option N	151.65
RD-80679	PCS-7 Manifold Option N	151.65
RD-82633	PCS-8 Manifold Option N	151.65

*Includes four valve mounted on the manifold

** Includes one manifold and no valves

Bimba Digital Panel Meter

DPM Series Application

Bimba Digital Panel Meter Model DPM Application Example



The DPM controller is ideal for measuring and gauging applications. The measurement repeatability, when combined with the PFC, is 0.001 inch per inch of stroke. The DPM supplies the PFC with a very accurate excitation voltage and has a 16 bit A/D converter. The DPM/PFC combination can be used as a Go/No Go gauge for in process quality control, among other things. A typical application follows:

Desired Result: In line process control verification to determine if parts meet required specifications.

Example One

The DPM is used in conjunction with a PFC cylinder to verify part specifications during an assembly process, ensuring quality of parts. RS-485 communications are used to monitor the PFC displacement remotely from the DPM. (The RS-485 protocol allows up to 32 devices to be connected to one port, and is less susceptible to signal noise since the analog to digital conversion is done in the DPM controller, utilizing the same power supply and ground planes as the PFC.) This information will be read by a PLC. The PLC determines what should be done to the part based on the displacement values read. (i.e., Send part on to the next process, or divert to rework station.) Use the DPM/PFC combination to verify if nuts are present and tightened correctly by checking the height of the nut. Calibrate the DPM using four calibration points-zero, LCL (lower control limit), UCL (upper control limit), and full scale. Refer to the Quick Start Guide, or the DPM manual shipped with each

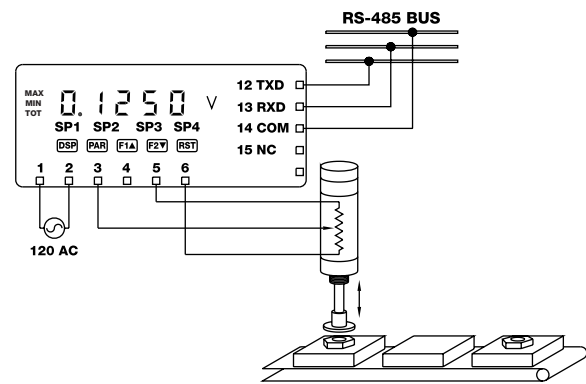

control unit for instructions. Configure the PLC with an RS-485 communication port. Program the PLC ladder logic according to your particular application. The ladder logic can be written to accommodate different sets of specifications for different product lines, making set up for the different products much easier and less time consuming.

Example Two

Read the programmable alarm outputs of the DPM from a PLC input card. The DPM outputs can be used to determine if a part measures to the proper tolerance or not. Alarm output one can be programmed to turn on at the upper control limit (UCL) of the part specification, and alarm output two can be programmed to turn on at the lower control limit (LCL) of the part specification. When the PFC is extended to measure the part, the PLC can read the DPM setpoint alarm outputs to

determine if the part conforms to the proper specifications. After the PFC is extended against the part, the PLC reads the DPM outputs. If no setpoint alarm turns on, this means that the PFC displacement is above the UCL, and the part is too big. If setpoint alarm one is on, this means that the part is in the good tolerance zone. If both setpoint alarms are on, this means that the part is either too small, or the part is not present.

Bimba Digital Panel Meter

Model DPM - 1 / 8 DIN Universal DC Input Panel Meter

Bimba Model DPM Digital Set Point Controller

The Bimba DPM may be used with the Position Feedback Cylinder. The controller provides a digital LED readout that may be calibrated to indicate the position of the cylinder in desired units. The PFC/DPM combination is ideal for measuring and gauging applications. The controller includes the following features:

- PFC Compatible Excitation and Input Impedance
- 120 VAC Input Voltage
- 16 Point Calibration Feature for Increased PFC Linearity
- Max and Min Reading Memory
- 5 Digit Display
- Programmable Function Keys
- Optional Serial Communication, Including RS-232, RS-485 and DeviceNet®
- Optional Analog Card with 16 bit Resolution
- NEMA 4X/IP65 Sealed Front Bezel
- CE Compliant
- Fast Input and Output Rates-Programmable

General Description

The DPM embodies many features and performance capabilities to suit a wide range of indication requirements. The meter employs advanced technology for stable, drift free readout, while incorporating features that provide flexibility now and in the future with Plug-in option cards. The option cards afford the opportunity to easily configure the meter for the needs of the present while providing an upward migration path as control and indication needs evolve.

The DPM provides a precision excitation compatible for Bimba's PFC. 16-point input scaling feature improves PFC linearity if necessary. The meter provides a Max and Min reading memory with programmable capture time. The capture time is used to prevent detection of false max and min readings which may occur during start-up or unusual process events.

The signal totalizer (integrator) can be used to compute a time-input product. This can be used to provide a readout of totalized flow, calculate service intervals of motors and pumps, etc. The totalizer can also accumulate batch weighing operations.

The DPM comes standard with four sourcing setpoint outputs. The setpoint alarms can be configured in modes to suit a variety of control and alarm requirements.

- High and low absolute, high and low deviation and band acting
- Balanced or unbalanced hysteresis
- On and off delay timers
- Auto reset or latching modes
- Reverse phase output and/or panel indicator
- Selection of alternate list of setpoint values

Optional accessory cards also facilitate bus communications. These include RS232, RS485 and DeviceNet. Readout values and setpoint alarm values can be controlled through the bus. Additionally, the meter has features that allow a remote computer to directly control the outputs of the meter. This is useful during commissioning phases and diagnostic use. With a communication card installed, set-up software allows configuration from a PC. The configuration data can be saved to a file for later recall. Contact Bimba for information if required.

Once the meter has been initially configured, the parameter list may be locked out from further modification in it's entirety or only the setpoint values can be made accessible.

The meter has been specifically designed for harsh industrial environments. With NEMA4 X/IP65 sealed bezel and extensive testing of noise effects to CE requirements, the meter provides a tough and reliable local readout.



CAUTION: Read complete instructions prior to installation and operation of the unit.



CAUTION: Risk of electric shock.

Dimensions "In Inches (mm)"

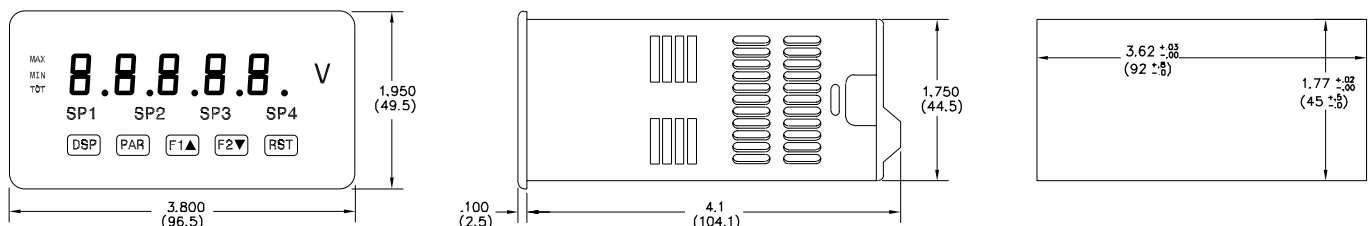

Note: Recommended minimum clearance (behind the panel) for mounting clip installation is 2.1" (53.4) H x 5.5" (140) W.

Bimba Digital Panel Meter

DPM Specifications

- DISPLAY:** 5 digit, 0.56" red LED, (-19999 to 99999)
- POWER:** 85 to 250 VAC, 50/60 Hz, 15 VA
Isolation: 2300 Vrms for 1 min. to all inputs and outputs.
- ANNUNCIATORS:**
MAX - max readout selected
MIN - min. readout selected
TOT - totalizer readout selected, flashes when total overflows
SP1 - setpoint alarm 1 is active
SP2 - setpoint alarm 2 is active
SP3 - setpoint alarm 3 is active
SP4 - setpoint alarm 4 is active
Units Label - software controlled units label backlight
- KEYPAD:** 3 programmable function keys, 5 keys total
- A/D CONVERTER:** 16 bit resolution
- UPDATE RATES:**
A/D conversion rate: 20/readings sec
Step response: 200 msec. max. to within 99% of final readout value (digital filter and internal zero correction disabled)
700 msec. max. (digital filter disabled, internal zero correction enabled).
The meter periodically (every 12 seconds) imposes a 500 msec delay to compensate for internal zero drift. If the delay affects applications where step response is critical, it can be defeated. Set the display update to 20/sec to disable. In this case, add a zero error of 0.1% FS over the 0 to 50°C range.
Display update rate: 1 to 20 updates/sec
Setpoint output on/off delay time: 0 to 3275 sec
Analog output update rate: 0 to 10 sec
Max./Min. capture delay time: 0 to 3275 sec
- RANGE OVERLOAD RESPONSE:**
Display flashes [LOL] at approximately 105% above range
Display flashes [ULUL] at approximately -5% below range
- DPM PFC INPUT:**

Accuracy* (18 to 28C)	Accuracy* (0 to 50C)	Impedance/ Compliance	Max Continuous Overload	Resolution
0.03% of reading +3 mV	0.12% of reading + 4 mV	1.066 Mohm	300 V	1mV

* After 20 minute warm-up. Accuracy is specified in two ways: Accuracy over an 18 to 28°C and 10 to 75% RH environment; and accuracy over a 0 to 50°C and 0 to 85%RH (non-condensing environment). Accuracy over the 0 to 50°C range includes the temperature coefficient effect of the meter.

- EXCITATION POWER:**
9V ±4% initial value regulated, 130 mA max.
- LOW FREQUENCY NOISE REJECTION:**
Normal Mode: > 60 dB @ 50 or 60 Hz ±1%, digital filter off
Common Mode: >100 dB, DC to 120 Hz
- USER INPUTS (Logic Level):** Three software defined user inputs, jumper selectable for sink/source logic
Max. Continuous Input: 30 VDC

INPUT STATE	SINKING INPUTS (DEFAULT)	SOURCING INPUTS
	22 KΩ pull-up to +5 V	22 KΩ pull-down
Active	$V_{IN} < 0.7 \text{ VDC}$	$V_{IN} > 2.5 \text{ VDC}$
Inactive	$V_{IN} > 2.5 \text{ VDC}$	$V_{IN} < 0.7 \text{ VDC}$

Isolation To Sensor Input Common: Not isolated

- TOTALIZER:**
Time Base: second, minute, hour, or day
Time Accuracy: 0.01% typical
Decimal Point: 0 to 0.0000
Scale Factor: 0.001 to 65.000
Low Signal Cut-out: -19,999 to 99,999

Total: 9 digits, display alternates between high order and low order readouts

- CUSTOM LINEARIZATION:**
Data Point Pairs: Selectable from 2 to 16
Display Range: -19,999 to 99,999
Decimal Point: 0 to 0.0000
- SERIAL COMMUNICATIONS:** (RS232 or RS485)
Isolation To Sensor & User Input Commons: 500 Vrms for 1 min.
Working Voltage: 50 V
Not Isolated from all other commons.
Data: 7/8 bits
Baud: 300 to 19200
Parity: no, odd or even
Bus Address: selectable 0 to 99, Max. 32 meters per line (RS485)
Transmit Delay: Selectable for 2 to 50 msec or 50 to 100 msec (RS485)
- ANALOG OUTPUT :**
Types: 0 to 20 mA, 4 to 20 mA or 0 to 10 VDC
Isolation To Sensor & User Input Commons: 500 Vrms for 1 min.
Working Voltage: 50 V
Not Isolated from all other commons.
Accuracy: 0.17% of FS (18 to 28°C); 0.4% of FS (0 to 50°C)
Resolution: 1/3500
Compliance: 10 VDC: 10 KΩ load min.
20 mA: 500 W load max.
- Quad Sourcing Open Collector:**
(Standard with DPM):
QUAD SOURCING OUTPUT FIELD TERMINALS

20	- EXTERNAL SUPPLY
21	- 01 SRC.
22	- 02 SRC.
23	- 03 SRC.
24	- 04 SRC.
25	- COMMON

Type: Four isolated sourcing PNP transistors.
Isolation To Sensor & User Input Commons: 500 Vrms for 1 min.
Working Voltage: 50 V
Not Isolated from all other commons.
Rating: Internal supply: 24 VDC ± 10%, 30 mA max. total all four outputs.
External supply: 30 VDC max., 100 mA max. each output.

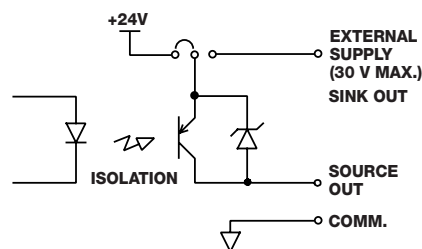
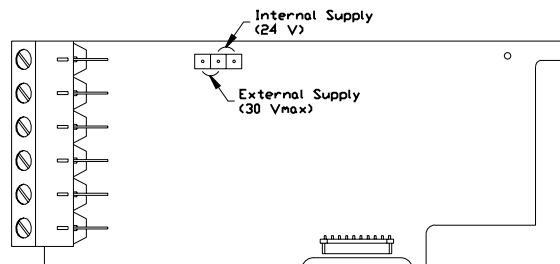

Bimba Digital Panel Meter

DPM Specifications Continued

Optional Quad Relay Card:

(Optional Accessory Card DPM-R):

QUAD RELAY OUTPUT FIELD TERMINALS

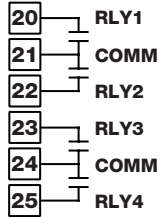

Type: Four FORM-A relays
Isolation To Sensor & User Input Commons: 2300 Vrms for 1 min.
Contact Rating: One Relay Energized: 3 amps @ 250 VAC or 30 VDC (resistive load), 1/10 HP @120 VAC, inductive load. Total current with all four relays energized not to exceed 4 amps
Life Expectancy: 100K cycles min. at full load rating. External RC snubber extends relay life for operation with inductive loads.

17. ENVIRONMENTAL CONDITIONS:

Operating Temperature Range: 0 to 50°C (0 to 45°C with all three plug-in cards installed)

Storage Temperature Range: -40 to 60°C

Operating and Storage Humidity: 0 to 85% max. non-condensing

Altitude: Up to 2000 meters

18. CERTIFICATIONS AND COMPLIANCES: ELECTROMAGNETIC COMPATIBILITY

Notes:

1. Self-recoverable loss of performance during EMI disturbance at 10 V/m: Measurement error less than 2% of full scale.

For operation without loss of performance:

Mount unit in a metal enclosure (Buckeye SM7013-0 or equivalent)

Route power and I/O cables in metal conduit connected to earth ground.

Refer to the Application Guide for additional EMC information.

Immunity to EN 50082-2

electrostatic discharge	EN 61000-4-2	level 3; 8 Kv air
electromagnetic RF fields	EN 61000-4-3	level 3; 10 V/m ¹ 80 MHz - 1 GHz
fast transients (burst)	EN 61000-4-4	level 4; 2 Kv I/O level 3; 2 Kv power
RF conducted interference	EN 61000-4-6	level 3; 10 V/rms 150 KHz - 80 MHz
simulation of cordless telephones	ENV 50204	level 3; 10 V/m 900 MHz ±5 MHz 200 Hz, 50% duty cycle

Emissions to EN 50081-2

RF interference	EN 55011	enclosure class A power mains class A
-----------------	----------	--

19. **CONNECTIONS:** High compression cage-clamp terminal block
Wire Strip Length: 0.35" (9 mm)

Wire Gauge Capacity: One 14 AWG solid or Two 18 AWG

20. **CONSTRUCTION:** This unit is rated for NEMA 4X/IP65 indoor use. IP20 Touch safe. Installation Category II, Pollution Degree 2. One piece bezel/case. Flame resistant. Synthetic rubber keypad. Panel gasket and mounting clip included.

21. **WEIGHT:** 10.4 oz. (295 g)



Safety Summary

All safety related regulations, local codes and instructions that appear in the manual or on equipment must be observed to ensure personal safety and to prevent damage to either the instrument or equipment connected to it. If equipment is used in a manner not specified by the manufacturer, the protection provided by the equipment may be impaired. Do not use this unit to directly command motors, valves, or other actuators not equipped with safeguards. To do so can be potentially harmful to persons or equipment in the event of a fault to the unit.

Jumper Link Functions

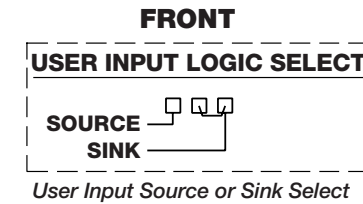

Front Panel

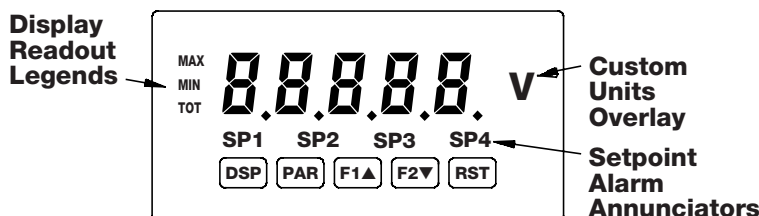

KEY DISPLAY MODE OPERATION

DSP	Index display through max/min/total/input readouts
PAR	Access parameter list
F1▲	Function key #1; hold for 3 seconds for Second Function #1
F2▼	Function key #2; hold for 3 seconds for Second Function #2
RST	Reset (function key)

PROGRAMMING MODE OPERATION

Quit programming and return to display mode
Store selected parameter and index to next parameter
Increment selected parameter value
Decrement selected parameter value
Hold with F1▲, F2▼ to scroll value by x1000

Bimba Digital Panel Meter

Basic Connections

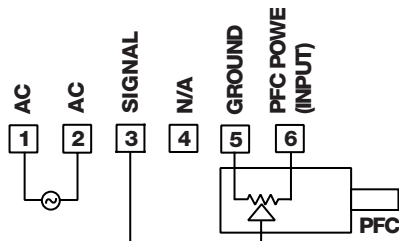

Note: Option card field connections are supplied with the card.

Wire Colors

Wires	6" Leads	Plug
Input	Red	Blue
Ground	Black	Black
Output	White	Brown

Custom Units Overlay

The meter has a backlit units indicator that can be customized to the application. The backlight is turned on by programming the "b-Lit" parameter. Overlays are available in the Units Label Kit. To install an overlay, remove the unit from the case. Select the label and apply it to the label frame, noting that the label must be aligned accurately. Install the label frame to the display board in the alignment holes located on the right side of the display.

Plug-In Cards

The meter has three plug-in card slots. Each slot is dedicated to a specific function. These functions are:

- **Setpoint Outputs**
- **Analog Outputs**
- **Communication Option**

The plug-in cards can be used in any combination, however, it is only possible to use one type of card from each category. Cards can be installed initially, or at a later date as system needs arise.

Devicenet Plug-In Card

A DeviceNet communication port can be added to the meter. DeviceNet is a high level bus protocol based upon the CAN specification. The protocol allows the integration of devices of different types and manufacturers within a common communication framework.

Analog Output Plug-In Card

The analog output is available as a Plug-in card. Either the 20 mA or the 10 V output can be used. The output can be scaled independent of the input range. Reverse acting output is possible by reversing the scaling point positions. Other features are selectable update rate and output source selection.

RS485 Plug-In Card

An RS485 communication port can be added with a Plug-in card. RS485 offers multi-drop bus communications. All devices connect in parallel on a 485 bus. Only one device is permitted to transmit at any one time, while all other devices are in receive mode. The meter controls the bus when it transmits data, otherwise the meter is in the receive mode.

RS232 Plug-In Card

An RS232 communication port can be installed with a Plug-in card. RS232 is intended to allow only 2 devices to communicate to each other (i.e., printer or computer). For more information, See DPM Serial Application Guide.

Inputs

Voltage Inputs

The Bimba PFC uses the $\pm 20V$ range (default).

Scaling

The meter has been factory calibrated on all ranges as a basic multimeter (voltmeter/ammeter/ohmmeter). The basic meter readout can then be post scaled to read out in the process units (level, flow, temperature, etc.). The meter provides two ways in which to scale the display:

Key-in: Key in the input and display scaling points using known data.

Apply: Apply the actual input value and key in the corresponding display value. The meter records the input value applied.

For processes that require linearity compensation, up to 16 scaling points can be used for correction. The scaling range is extended up to five digits of resolution with selectable display rounding factors.

Input Features

A unique adaptive input filter is used. Whenever the difference between one reading and the next is less than the filter band value, the input is filtered. When the difference exceeds the filter band value, the input is not filtered. This avoids the usual compromise between using a relative high time constant for good noise rejection and using a low time constant filter for quick step response.

The readout can be corrected for process zero errors with an offset value. A tare function zeros the readout via a function operation.

Function Keys and User Inputs

The Function Keys and User inputs can be programmed to perform specific meter control operations. Function Keys #1 and #2 each have two types of functions, primary and secondary. The primary function is executed the instant the key is pressed. Holding the key for three seconds executes the second function. If the key is not held for 3 seconds, the second function is not executed. To implement a hidden key, program no function for the primary and program the desired function for the second.

The three user inputs can be selected for sinking or sourcing logic.

Max and Min Reading Detection

The meter records the maximum (max) and minimum (min) process inputs. Conditions such as valve activation, sudden change in material flow rate, etc., can result in false peaks which are not reflective of the true maximum and minimum of the process. In this case, Max and Min capture delay times can be used to prevent the detection of false maximums and minimums.

Bimba Digital Panel Meter

Basic Connections

Parameter Lock Mode

A user input can be used to lock the parameter list. When the user input is active, the meter is in the protected parameter mode, where it is only possible to access the setpoint values and the security code.

It is possible to lock the parameter list without using a user input as a program lock function. In this case, set the security code to a non-zero value. With a non-zero security value set, press the PAR Key to view the programmed setpoint values. The security code requires a “key” value to gain access to the full parameter list.

Installation

The DPM meets NEMA 4X/IP65 requirements for indoor use when properly installed. The unit is intended to be mounted into an enclosed panel. Prepare the panel cutout to the dimensions shown in the Dimensions drawing. Remove the panel latch and cardboard sleeve from the unit and discard the cardboard sleeve. Slide the panel gasket over the rear of the unit to the back of the bezel. The unit should be installed fully assembled. Insert the unit into the panel cutout. While holding the unit in place, push the panel latch over the rear of the unit so that the tabs of the panel latch engage in the slots on the case. The panel latch should be engaged in the farthest forward slot possible. To achieve a proper seal, tighten the latch screws evenly until the unit is snug in the panel (Torque to approximately 7 in-lbs [79N-cm]). Do not over-tighten the screws.

Ordering Information

Model Number	Description	List Prices
DPM	Base Unit - Includes Excitation, Quad Solid State Outputs	\$513.45
DPMA	Base Unit with Analog Card	619.85
DPMR	Base Unit with Quad Form A 120VAC Relay	601.10
DPMS	Base Unit with RS-485 Serial Output	601.10
DPM-485	RS-485 Plug-In Accessory Card	87.75
DPM-232	RS-232 Plug-In Accessory Card	87.75
DPM-DNET	DeviceNet Plug-In Accessory Card	212.95
DPM-A	Analog Plug-In Accessory Card	137.80
DPM-R	Quad Form A 120 VAC Relay Plug-In Accessory Card	87.75

Bimba Electronic Controller

Electronic Controller



The Bimba Electronic Controllers provide 10 VDC regulated power to the Position Feedback Cylinder. Four models are available for AC or DC input and voltage or current output. Each controller offers both dual set point and scaled analog output functions. The controllers are strictly analog in nature and are **not** closed loop motion controllers.

The Bimba electronic controller is ideal for applications where:

- The main system controller being used to interface with the PFC does not have the required 1 Mohm input impedance.
- Accuracy is not a key consideration (\pm 0.030" or higher).
- The application requires a fast responding scalable analog output signal.
- The customer desires to cycle between two variable set points without needing to stop and hold a position.

Typical applications include web tensioning or dancer arm control. The Bimba electronic controller would be used as an interface between the PFC cylinder and the customers web tensioning or dancer arm controller.

Model	Input Power	Scalable Output
120AC4-20mA	120 VAC	4 - 20 mA
120AC0-10DC	120 VAC	0 - 10 VDC
12/24DC4-20mA	12-24 DC	4 - 20 mA
12/24DC0-10DC	12-24 DC	0 -10 VDC

List Prices

Model	Price
120AC4-20MA	\$263.05
120AC0-10DC	263.05
12/24DC4-20MA	300.60
12/24DC0-10DC	300.60

Bimba Electronic Controller

Dimensions

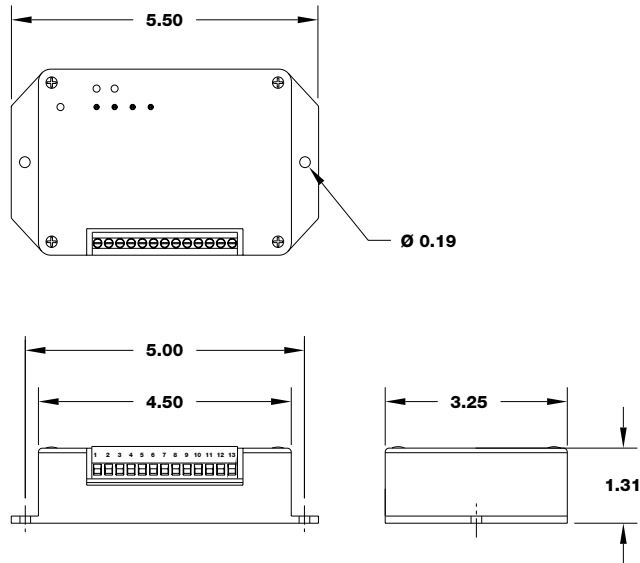

Electronic Controller Specifications

Auxiliary Power Requirement:

AC Models	100 to 135 VAC (115 VAC Input) 200 to 270 VAC (230 VAC Input)
DC Models	11.8 to 26 VDC (12/24 VDC Input)

Power Requirement:

AC Models	5 VA maximum (120 to 230 VAC)
DC Models	1.2 VA maximum (12 VDC) 2.4 VA Max (24 VDC)

Frequency Range	50/60 HZ
Transducer Excitation Voltage	10 VDC (Nominal)
Electrical Connections	13 position Euro Style terminal block

Dielectric Strength:

AC Models	2000 VAC (All Inputs to all Outputs) 2000 VAC (Terminals to case)
DC Models	2000 VAC (All Inputs to relay Outputs) 2000 VAC (terminals to Case)

Note: The Negative power supply connection is common to the analog signal output.

Transient Protection All inputs and outputs are designed to withstand transient energy levels normally associated with Category III service locations as defined by IEC 644. Industrial installations that are typical of this environment would include most distribution, feeder or branch circuit connections that are not located at the immediate service entrance.

Shipping Weight	Approx. 12 oz.
Operating Temperature Range	(-30°C to +70°C) -22°F to 160° F (0°C to +70°C) 32°F to 160° F for 12 VDC Operation
Storage Temperature Range	(-40°C to +85°C) -40°F to 185° F
Enclosure Dimensions	1.31" H x 5.50" W x 3.25" D

Position Feedback
Cylinders

Position Feedback
Cylinder Non Contact

Position Feedback
Cylinder Rod Lock

Position Feedback
Cylinder Accessories

Position Feedback
Pneu-Turn

Position
Control System

Digital Panel Meter

Electronic Controller

PLC/PCS/PTC
Application Checklist

Bimba Electronic Controller

Electronic Controller Specifications

Position Feedback Control Module

Unless noted otherwise:

Ambient Temperature	=	(25°C) 77°F Nominal
Aux Power (AC Models)	=	120 VAC, 60 HZ
Aux Power (DC Models)	=	24 VDC

Relay Outputs

Control Limit Set Point Range	2 independent adjustments settable from 0 to 100% of cylinder stroke
Temperature Influence on Control Limits	$\pm 0.01\%$ stroke /°C (-30°C to +70°C)
Output Contact Ratings	5 A, 250 VAC, 0.8 power factor (general use) 5 A, 30 VDC (resistive) 360 VA, 240V, 0.4 power factor (Pilot Duty)
Output Contact Configuration	2 independent form C (SPDT) relays Each relay has a corresponding control limit set point adjustment
Response Time (Excluding Bounce)		
Operate Time	=	8 mS TYP/12 mS maximum
Release Time	=	4mS TYP/6 mS maximum
Mechanical Life	20,000,000 operations minimum

Analog Outputs

Output Load Specifications	0 to 10 VDC @ 10 mA maximum 4 to 20 mA @ 500 Ω maximum loop resistance 350 Ω for 12 VDC input
Zero Offset Adjustment Range	$\pm 5V$ (10 VDC output) $\pm 8mA$ (4 to 20 mA output)
Gain Adjustment Range	From 0.5 to 2.0 times input signal
Output Limits	13v typical (10 VDC output) 25mA typical (4 to 20 mA output)
Temperature Influence on Analog Output	$\leq \pm 0.02\%$ Full Scale Output /°C (-30°C to +70°C)
Output Ripple	<0.2% of Full Scale Output
Response Time (0 to 90% of final value)		
0 to 10 VDC	=	2mS TYP/3 mS maximum
4 to 20 mA	=	2 mS TYP/3 mS maximum

Bimba PFC/PCS/PTF Application Checklist

Position Feedback Cylinder (PFC or PFCN) And Pneumatic Control System (PCS) Application Checklist

Note: Use the separate Checklist for the Position Feedback Pneu-Turn (PTF)

Step 1. Photocopy the sketch and checklist sheet

Step 2. Complete the sketch and checklist

Step 3. Mail or fax the sketch and checklist to your local stocking distributor

Name: _____	Date _____
Company name: _____	
Address: _____	
Phone: _____	Fax: _____

Request PFC model number recommended by engineering:

Yes _____ No _____

If no, what is the PFC model to be used in your application?: _____

Operational temperature range: _____ °F to _____ °F

Used in a wash down environment?: Yes _____ No _____

If yes, what chemicals are present?: _____

FILL OUT THIS SECTION FOR PFC MEASURING APPLICATIONS

Measurement repeatability required: _____ in.

Stroke needed (1" minimum, 24" maximum) _____ in.

Output signal preference: Analog 0 to 10 VDC _____
Analog 4 to 20 mA _____
Quad sourcing open collector (PNP) _____
Relay(s): Yes _____ Number of relays: _____

Contact rating: 0 to 250 VAC _____
0 to 30 VDC _____

Digital: RS232 _____
RS485 _____
Device net _____

FILL OUT THIS SECTION FOR POSITION APPLICATIONS UTILIZING THE PCS PNEUMATIC MOTION CONTROL SYSTEM

Describe application: _____

Position repeatability: _____

Position Feedback
Cylinders

Position Feedback
Cylinder Non Contact

Position Feedback
Cylinder Rod Lock

Position Feedback
Cylinder Accessories

Position Feedback
Pneu-Turn

Position
Control System

Digital Panel Meter

Electronic Controller

PFC/PCS/PTF
Application Checklist

Bimba PFC/PCS/PTF Application Checklist

Payload Mass: _____

Estimated Coef. of friction: _____

Velocity required: _____

Timing required: _____

Air pressure available: _____ **Application orientation:** Vertical _____ Horizontal _____

Weight and material of load: Material _____ Weight _____ lb. _____ oz.

Stroke needed (1" minimum, 24" maximum) _____

Is there any External Friction in the application? Yes _____ No _____

Application Sketch

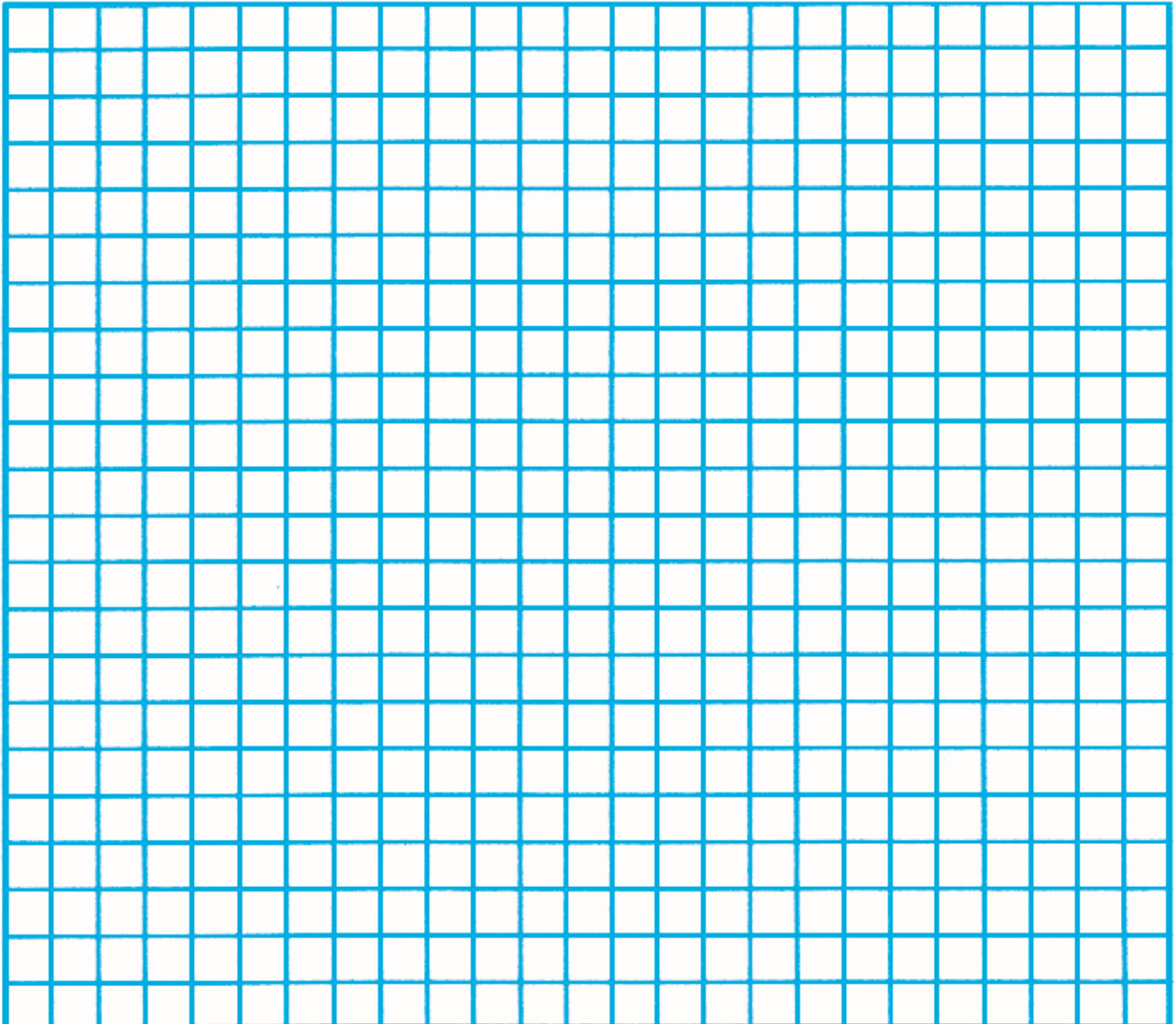

Bimba PTF Application Checklist

Pneu-Turn Position Feedback Application Checklist

This checklist makes sizing and selecting Bimba actuators easier. Bimba's Engineering Department will assist you by providing a detailed analysis of your application and, based on the information in the application checklist, will help you choose the actuators best suited to your needs.

- Step 1. Photocopy the sketch and checklist sheets.**
- Step 2. Complete the sketch and checklist.**
- Step 3. Mail or fax the sketch and checklist to your local stocking distributor.**

Date: _____

Your Name: _____

Company: _____

Address: _____

Phone: _____

Fax: _____

Request Pneu-Turn model number recommended by Engineering? Yes _____ No _____

If no, Pneu-Turn model number to be used in your application: _____
 Air _____ psi Repeatability Required _____ Degrees

Torque Required:
 0 – 15 in-lbs. 75 – 100 in-lbs.
 15 – 35 in-lbs. 200 – 500 in-lbs.
 35 – 75 in-lbs. other: _____

Application closest to (circle one):
 Fig. 1 Fig. 2 Fig. 3 Fig. 4 Fig. 5 Fig. 6 Fig. 7

Dimensions applicable to your lever arm:
 Radius _____ in. A1 _____ in.
 A2 _____ in. B _____ in.

Weight and material of lever arm and attachments:
 _____ lbs. _____ oz. material: _____

Load to be moved by the lever arm:
 _____ lbs. _____ oz.

Distance from the center of the load to the center of the shaft: _____ in.

Shaft Mounted: (shaft, cylinders)

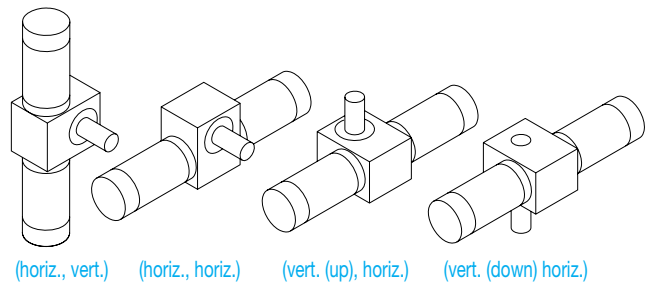

Axial loading? Yes _____ No _____
 If yes, direction with reference to pushing or pulling the standard shaft: _____

Rotation of lever arm: _____ degrees

Time needed to move load in one direction:
 _____ secs. Opposite direction _____ secs.

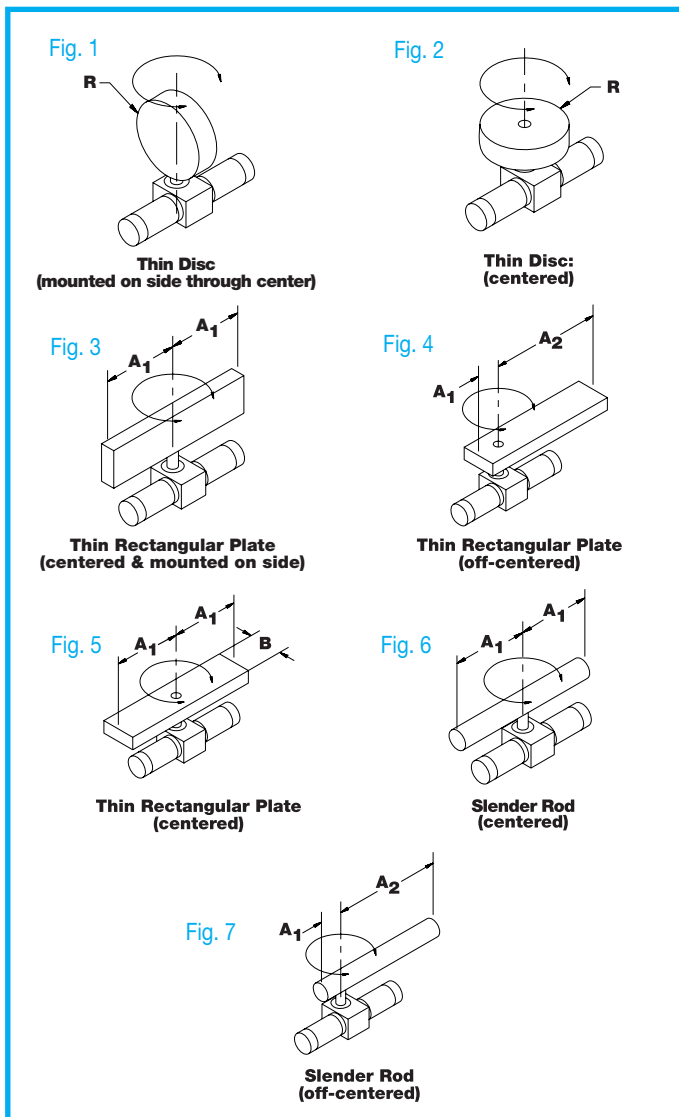

Position Feedback Cylinders
 Position Feedback Cylinder Non Contact
 Position Feedback Cylinder Rod Lock
 Position Feedback Cylinder Accessories
 Position Feedback Pneu-Turn
 Position Control System
 Digital Panel Meter
 Electronic Controller
 PFC/PCS/PTF Application Checklist

Notes