

---

# **Biofuel: Sources, Extraction and Determination**

---

Emad A. Shalaby

Additional information is available at the end of the chapter

<http://dx.doi.org/10.5772/51943>

---

## **1. Introduction**

Biofuel is a type of fuel whose energy is derived from biological carbon fixation. Biofuels include fuels derived from biomass conversion (Figure 1, JICA, Okinawa, Japan), as well as solid biomass, liquid fuels and various biogases. Although fossil fuels have their origin in ancient carbon fixation, they are not considered biofuels by the generally accepted definition because they contain carbon that has been "out" of the carbon cycle for a very long time. Biofuels are gaining increased public and scientific attention, driven by factors such as oil price hikes, the need for increased energy security, concern over greenhouse gas emissions from fossil fuels, and support from government subsidies. Biofuel is considered carbon neutral, as the biomass absorbs roughly the same amount of carbon dioxide during growth, as when burnt. The chemical composition of different kinds of biomass was shown in Table 1.

Biodiesel as one from important biofuel types is made from vegetable oils and animal fats. Biodiesel can be used as a fuel for vehicles in its pure form, but it is usually used as a diesel additive to reduce levels of particulates, carbon monoxide, and hydrocarbons from diesel-powered vehicles. Biodiesel is produced from oils or fats using transesterification and is the most common biofuel in Europe.

Bioethanol is an alcohol made by fermentation, mostly from carbohydrates produced in sugar or starch crops such as corn or sugarcane. Cellulosic biomass, derived from non-food sources such as trees and grasses, is also being developed as a feedstock for ethanol production. Ethanol can be used as a fuel for vehicles in its pure form, but it is usually used as a gasoline additive to increase octane and improve vehicle emissions. Bioethanol is widely used in the USA and in Brazil. Current plant design does not provide for converting the lignin portion of plant raw materials to fuel components by fermentation.

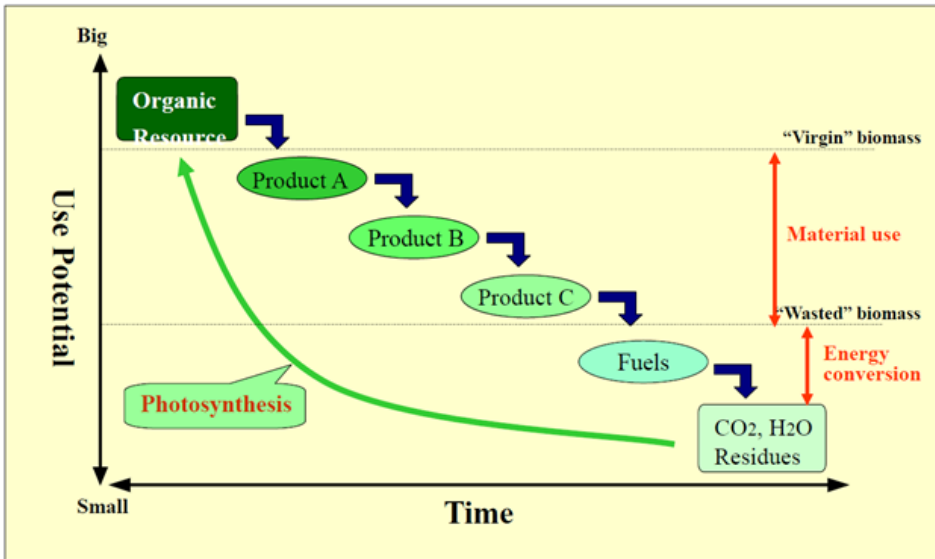

Figure 1. Cascade use of biomass

Kinds of biomass		Characteristics									
		Moisture content (%)	Solid substance(%)				Minerals(dry matter%)				
			Bacteria decomposition	Hard decomposition	Total	Minerals	Carbon (T-C)	Nitrogen (T-N)	Phosphorus (T-P)	Potassium(T-K)	
Livestock waste	Beef cow dung	78.0	5.3	12.3	17.6	4.4	35.1	2.5	1.0	1.5	
	Dairy cow	Dung	85.0	3.6	8.4	12.0	3.0	35.1	2.5	1.0	1.5
		Mixed	90.0	2.4	5.6	8.0	2.0	35.1	2.5	1.0	1.5
	Pig	Dung	72.0	10.5	10.5	21.0	7.0	35.1	3.5	2.5	1.5
		Mixed	90.0	3.8	3.8	7.6	2.5	35.1	3.5	2.5	1.5
	Poultry	70.0	15.8	5.2	21.0	9.0	35.1	5.5	3.0	3.0	
Food residue	Tofu grounds	80.0	17.4	1.6	19.0	1.0	44.2	4.5	0.5	1.0	
Garbage	Garbage	80.0	14.2	2.5	16.7	3.3	44.2	2.5	2.4	3.4	
	Rubbish	50.0	29.4	12.6	42.0	8.0	55.0	1.0	—	—	
	Used cooking oil	—	—	—	—	—	71.4	—	—	—	
Slurry	Human waste	97.8	0.7	1.0	1.7	0.5	38.4	4.5	2.1	0.2	
	Septic tank	99.0	0.3	0.5	0.8	0.2	38.4	4.5	1.1	0.1	
	Sewage	78.0	5.8	8.6	14.4	7.6	38.4	4.5	2.3	0.3	
Crop-wood residue	Wood residue	35.0	12.8	51.2	64.0	1.0	52.0	0.4	0.02	0.1	
	Crop residue	12.0	32.0	38.7	70.7	17.3	40.9	0.6	0.09	0.4	

Table 1. Average properties of biomass

In 2010 worldwide biofuel production reached 105 billion liters (28 billion gallons US), up 17% from 2009, and biofuels provided 2.7% of the world's fuels for road transport, a contribution largely made up of ethanol and biodiesel. Global ethanol fuel production reached 86 billion liters (23 billion gallons US) in 2010, with the United States and Brazil as the world's top producers, accounting together for 90% of global production. The world's largest biodiesel producer is the European Union, accounting for 53% of all biodiesel production in 2010. As of 2011, mandates for blending biofuels exist in 31 countries at the national level and in 29 states/provinces. According to the International Energy Agency, biofuels have the potential to meet more than a quarter of world demand for transportation fuels by 2050.

## 2. Different sources of biofuel

Here are 4 biofuel sources, with some of their application in developmental stages, some actually implemented:

### 2.1. Algae

*Algae come from* stagnant ponds in the natural world, and more recently in algae farms, which produce the plant for the specific purpose of creating biofuel. *Advantage of algae focude on the followings:* No CO<sub>2</sub> back into the air, self-generating biomass, Algae can produce up to 300 times more oil per acre than conventional crops. Among other uses, algae have been used experimentally as a new form of green jet fuel designed for commercial travel. At the moment, the upfront costs of producing biofuel from algae on a mass scale are in process, but are not yet commercially viable (Figure 2)

### 2.2. Carbohydrate (sugars) rich biomaterial

*It comes from* the fermentation of starches derived from agricultural products like corn, sugar cane, wheat, beets, and other existing food crops, or from inedible cellulose from the same. Produced from existing crops, can be used in an existing gasoline engine, making it a logical transition from petroleum. It used in Auto industry, heating buildings ("flueless fireplaces") At present, the transportation costs required to transport grains from harvesting to processing, and then out to vendors results in a very small net gain in the sustainability stakes.

### 2.3. Oils rich biomaterial

*It comes from* existing food crops like rapeseed (aka Canola), sunflower, corn, and others, after it has been used for other purposes, i.e food preparation ("waste vegetable oil", or WVO), or even in first use form ("straight vegetable oil", or SVO). Not susceptible to microbial degradation, high availability, re-used material. It is used in the creation of biodiesel fuel for automobiles, home heating, and experimentally as a pure fuel itself. At present, WVO or SVO is not recognized as a mainstream fuel for automobiles. Also, WVO and SVO are susceptible to low temperatures, making them unusable in colder climates.



**Figure 2.** Dense algal growth in four pilot-scale tank bioreactors fed by treated wastewater from the Lawrence, Kansas (USA) wastewater treatment plant (photo by B. Sturm). Each fiberglass bioreactor has an operating volume of ten cubic meters of water, and is operated as an air-mixed, flow-through vessel. Nutrient-rich wastewater inflows are pumped in through the clear plastic hose (blue clamp), and water outflow occurs through the white plastic pipe shown at the waterline. These bioreactors are intended to be operated year-round, as the temperature of the inflowing wastewater is consistently ca. 10 - 8°C.

#### 2.4. Agriculture wastes (organic and inorganic sources)

It comes from agricultural waste which is concentrated into charcoal-like biomass by heating it. Very little processing required, low-tech, naturally holds CO<sub>2</sub> rather than releasing it into the air. Primarily, biochar has been used as a means to enrich soil by keeping CO<sub>2</sub> in it, and not into the air. As fuel, the off-gasses have been used in home heating. There is controversy surrounding the amount of acreage it would take to make fuel production based on biochar viable on a meaningful scale. Furthermore, use of agriculture wastes which rich with inorganic elements (NPK----) as compost (fertilizer) in agriculture.

### 3. Comparison between different extraction methods of bio-diesel, bio-ethanol, biogas (bio-methane)

#### 3.1. Biodiesel

##### 3.1.1. Biodiesel extraction

Biodiesel is a clean-burning diesel fuel produced from vegetable oils, animal fats, or grease. Its chemical structure is that of fatty acid alkyl esters (FAAE). Biodiesel as a fuel gives much lower toxic air emissions than fossil diesel. In addition, it gives cleaner burning and has less sulfur content, and thus reducing emissions. Because of its origin from renewable resources, it is more likely that it competes with petroleum products in the future. To use biodiesel as a fuel, it should be mixed with petroleum diesel fuel to create a biodiesel-blended fuel. Biodiesel refers to the pure fuel before blending. Commercially, biodiesel is produced by transesterification of triglycerides which are the main ingredients of biological origin oils in the presence of an alcohol (e.g. methanol, ethanol) and a catalyst (e.g. alkali, acid, enzyme) with glycerine as a major by-product [Ma and Hanna, 1999 ; Dube et al., 2007 ]. After the reaction, the glycerine is separated by settling or centrifuging and the layer obtained is purified prior to using it for its traditional applications (pharmaceutical, cosmetics and food industries) or for the recently developed applications (animal feed, carbon feedstock in fermentations, polymers, surfactants, intermediates and lubricants) [Vicente et al., 2007].

However, one of the most serious obstacles to use biodiesel as an alternative fuel is the complicated and costly purification processes involved in its production. Therefore, biodiesel must be purified before being used as a fuel in order to fulfil the EN 14214 and ASTM D6751 standard specifications listed in Table 2; otherwise the methyl esters formed cannot be classified as biodiesel. Removing glycerine from biodiesel is important since the glycerine content is one of the most significant precursors for the biodiesel quality. Biodiesel content of glycerine can be in the form of free glycerine or bound glycerine in the form of glycerides. In this work we refer to the total glycerine, which is the sum of free glycerine and bound glycerine. Severe consequences may result due to the high content of free and total glycerine, such as buildup in fuel tanks, clogged fuel systems, injector fouling and valve deposits (Hayyan et al., 2010).

##### 3.1.2. Biodiesel extraction methods:

###### 3.1.2.1. One step transesterification

For the synthesis of biodiesel, the following materials were used: oil sample (FFM Sdn Bhd), methanol (Merck 99%), and potassium hydroxide (KOH) as a catalyst (HMGM Chemicals >98%). Methanol and potassium hydroxide were pre-mixed to prepare potassium methoxide, and then added to oil in the reactor with a mixing speed of 400 rpm for 2 h at 50 °C. The molar ratio of oil to methanol was 1:10. Finally, the mixture was left overnight to settle forming two layers, namely: biodiesel phase (upper layer) and the glycerin-rich phase (Figure 3).

Property	EN 14214		ASTM D 6751	
	Test method	Limits	Test method	Limits
Ester content	EN 14103	96.5% (mol mol <sup>-1</sup> ) min	-	-
Linolenic acid content	EN 14103	12.0% (mol mol <sup>-1</sup> ) max	-	-
Content of FAME <sup>a</sup> with ≥4 double bonds	-	1.0% (mol mol <sup>-1</sup> ) max	-	-
MAG <sup>b</sup> content	EN 14105	0.80% (mol mol <sup>-1</sup> ) max	-	-
DAG <sup>c</sup> content	EN 14105	0.20% (mol mol <sup>-1</sup> ) max	-	-
TAG <sup>d</sup> content	EN 14105	0.20% (mol mol <sup>-1</sup> ) max	-	-
Free glycerine	EN 14105	0.02% (mol mol <sup>-1</sup> ) max	ASTM D 6584	0.020% (w/w) max
Total glycerine	EN 14105	0.25% (mol mol <sup>-1</sup> ) max	ASTM D 6584	0.240% (w/w) max
Water and sediment or water content	EN ISO 12937	500 mg kg <sup>-1</sup> max	ASTM D 2709	0.050% (v/v) max
Methanol content	EN 14110	0.20% (mol mol <sup>-1</sup> ) max	-	-
(Na + K) content	EN 14108	5.0 mg kg <sup>-1</sup> max	UOP 391	5.0 mg kg <sup>-1</sup> max
(Ca + Mg) content	prEN 14538	5.0 mg kg <sup>-1</sup> max	-	-
P content	EN 14107	10.0 mg kg <sup>-1</sup> max	ASTM D 4951	0.001% (w/w) max
Oxidative stability (110 °C)	EN 14112	6 h min	-	-
Density (15 °C)	EN ISO 3675	860–900 kgm <sup>-3</sup>	-	-
Kinematic viscosity or viscosity (40 °C)	EN ISO 3104	3.5–5.0 mm <sup>2</sup> s <sup>-1</sup>	ASTM D 445	1.9–6.0 mm <sup>2</sup> s <sup>-1</sup>
Flash point	EN ISO 3679	120 °C min	ASTM D 93	130 °C min
Cloud point	-	-	ASTM D 2500	Not specified
Sulfur content	EN ISO 20864	10.0 mg kg <sup>-1</sup> max	ASTM D 5453	0.05% (w/w) max
Carbon residue	EN ISO 10370	0.30% (mol mol <sup>-1</sup> ) max	ASTM D 4530	0.050% (w/w) max
Cetane number	EN ISO 5165	51 min	ASTM D 613	47 min
Sulphated ash	ISO 3987	0.02% (mol mol <sup>-1</sup> ) max	ASTM D 874	0.020% (w/w) max
Total contamination	EN 12662	24 mg kg <sup>-1</sup> max	-	-
Copper strip corrosion (3 h, 50 °C)	EN ISO 2160	1 (degree of corrosion)	ASTM D 130	No. 3 max
Acid number or acid value	EN 14104	0.50 mg KOH g <sup>-1</sup> max	ASTM D 664	0.50 mg KOH g <sup>-1</sup> max
Iodine value	EN 14111	120 g I <sub>2</sub> ·100 g <sup>-1</sup> max	-	-
Distillation temperature (90% recovered)	-	-	ASTM D 1160	360 °C max

<sup>a</sup> FAME = fatty acid methyl esters.

<sup>b</sup> MAG = monoacylglycerines.

<sup>c</sup> DAG = diacylglycerines.

<sup>d</sup> TAG = triacylglycerine.

**Table 2.** Biodiesel specifications according to EN 14214, and ASTM D6751 standards.

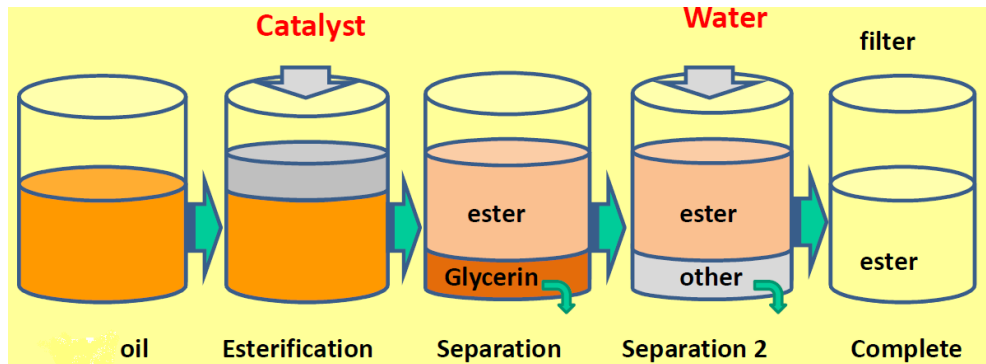

**Figure 3.** The biodiesel extraction process (steps).

### 3.1.2.2. Second step transesterification

The production methodology followed in this study was according to Tomosevic and Siler-Marinkovic [2003] with some modification, where the alkali-catalyzed transesterification was applied. Basically, methanol was the alcohol of choice and KOH was used as the catalyst. Potassium methoxide solution (PMS) was prepared freshly by mixing a pre-determined amount of methanol ( $\approx 12$  wt % of oil) with KOH ( $\approx 1.0$  wt % of oil) in a container until all the catalyst dissolved. The PMS was then added to 200 g of oil and

stirred vigorously for 30 min at 30°C. Then after, the mixture was carefully transferred to a separating funnel and allowed to stand for 4 h. the lower layer (glycerol, methanol and most of the catalysts) was drained out. The upper layer (methyl esters MEs, some methanol and traces of the catalyst) was transferred into another flask containing freshly prepared PMS mixed at 60 rpm under reflux at 60°C for 30 min. afterwards; the mixture was carefully transferred to a separating funnel and allowed to stand there over night. The glycerol was removed by gravity settling, whereas the obtained crude esters layer was transferred into water bath to remove excess methanol at 65°C and 20 kPa. The obtained crude methyl esters were then cleaned thoroughly by washing with warm (50°C) deionized water, dried over anhydrous  $\text{Na}_2\text{SO}_4$ , weighted and applied for further analysis (Shalaby and Nour, 2012; Shalaby, 2011).

#### 3.1.2.3. *Qualitative analysis of glycerol*

The Borax/phth test is special test for detection on the compound contain two neighboring hydroxyl group as in glycerol organic compound as the following:

1 ml glycerol layer mix with 1 ml of Borax/phth (red color) if the red color disappear in cold and appearing after heating (direct) this positive control.

#### 3.1.2.4. *Fourier transforms infrared spectroscopy (FTIR) analysis*

FTIR analysis was performed using instrument, Perkin Elmer, model spectrum one, for detection of transesterification efficiency of oil by determination of the active groups produced from these process.

The results obtained by Shalaby and Nour (2012) found that, two step transesterification of oil led to 100 % disappearance of hydroxyl group but this was less than 100 % in case of one step transesterification as shown in Figure (4).

## 3.2. Bioethanol

### 3.2.1. *Bioethanol extraction*

Bioethanol is one of the most important renewable fuels due to the economic and environmental benefits of its use. The use of bioethanol as an alternative motor fuel has been steadily increasing around the world for the number of reasons. 1) Fossil fuel resources are declining, but biomass has been recognized as a major reasons World renewable energy source. 2) Greenhouse gas emissions is one of the most important challenges in this century because of fossil fuel consumption, biofuels can be a good solution for this problem. 3) Price of petroleum in global market has raising trend. 4) Petroleum reserves are limited and it is monopoly of some oil-importing countries and rest of the world depends on them. 5) Also known petroleum reserves are estimated to be depleted in less than 50 years at the present rate of consumption. At present, in compare to fossil fuels, bioethanol is not produced economically, but according to scientific predictions, it will be economical about 2030.

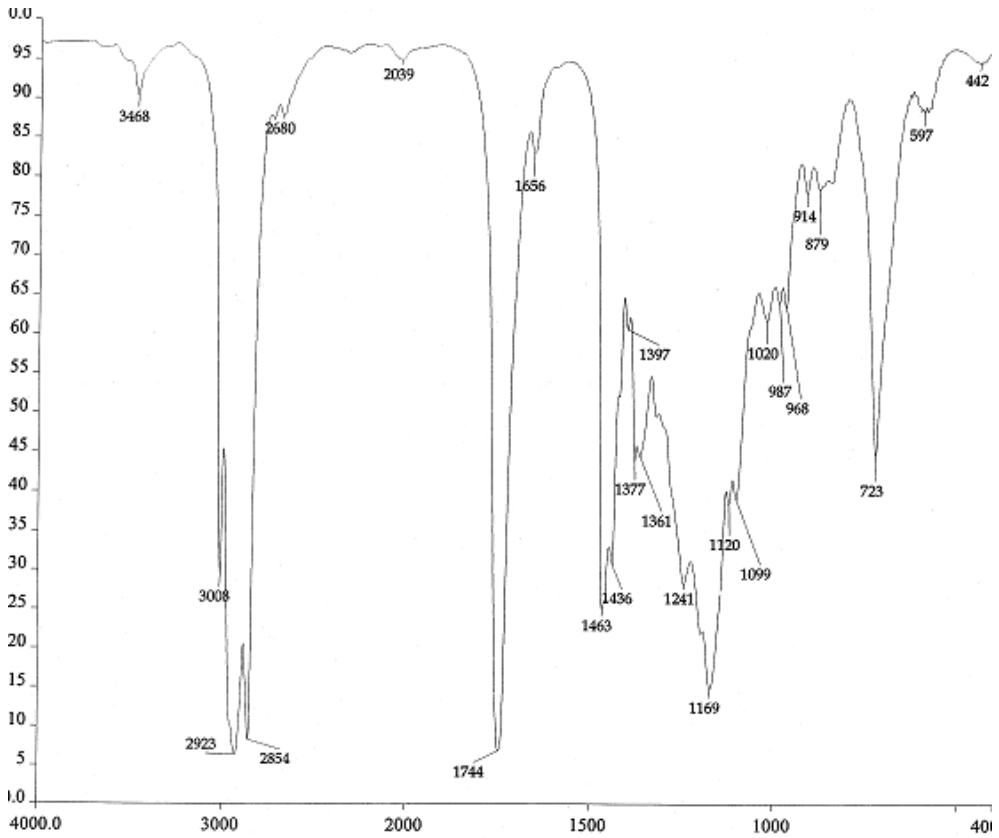

**Figure 4.** The IR spectrum of oil after two step transesterification (produced biodiesel) process

Biomass commonly gathers from agricultural, industrial and urban residues. The wastes used for bioethanol production are classified in three groups according to pretreatment process in sugary, starchy and lignocellulosic biomasses. Lignocellulosic biomass, including forestry residue, agricultural residue, yard waste, wood products, animal and human wastes, etc., is a renewable resource that stores energy from sunlight in its chemical bonds. Lignocellulosic biomass typically contains 50%-80% (dry basis) carbohydrates that are polymers of 5C and 6C sugar units. Lignocellulosic biomasses such as waste wood are the most promising feedstock for producing bioethanol.

Bioconversion of lignocellulosic biomass to ethanol is significantly hindered by the structural and chemical complexity of biomass, which makes these materials a challenge to be used as feedstock for cellulosic ethanol production. Cellulose and hemicellulose, when hydrolyzed into their component sugars, can be converted into ethanol through well-established fermentation technologies. However, sugars necessary for fermentation are trapped inside the crosslinking structure of the lignocellulose.



Conventional methods for bioethanol production from lignocellulosic biomasses take three steps: *pretreatment* (commonly acid or enzyme hydrolyses), *fermentation*, *distillation*. Pretreatment is the chemical reaction that converts the complex polysaccharides to simple sugar. pretreatment of biomass is always necessary to remove and/or modify the surrounding matrix of lignin and hemicellulose prior to the enzymatic hydrolysis of the polysaccharides (cellulose and hemicellulose) in the biomass. Pretreatment refers to a process that converts lignocellulosic biomass from its native form. In general, pretreatment methods can be classified into three categories, including physical, chemical, and biological pretreatment. In this step, biomass structure is broken to fermentable sugars. This project focused on chemically and biologically pretreatment. For example: this project shows the effect of sulfuric acid, hydrochloric acid and acetic acid with different concentration by different conditions also shows the effect of cellulase enzyme by different techniques. Then fermentation step in which there are a series of chemical or enzymatic reactions that converted sugar into ethanol. The fermentation reaction is caused by yeast or bacteria, which feed on the sugar such as *Saccharomyces cerevisiae*. After that, distillation step in which the pure ethanol is separated from the mixture using distiller which boil the mixture by heater and evaporate the mixture to be condensate at the top of the apparatus to produce the ethanol from joined tube.

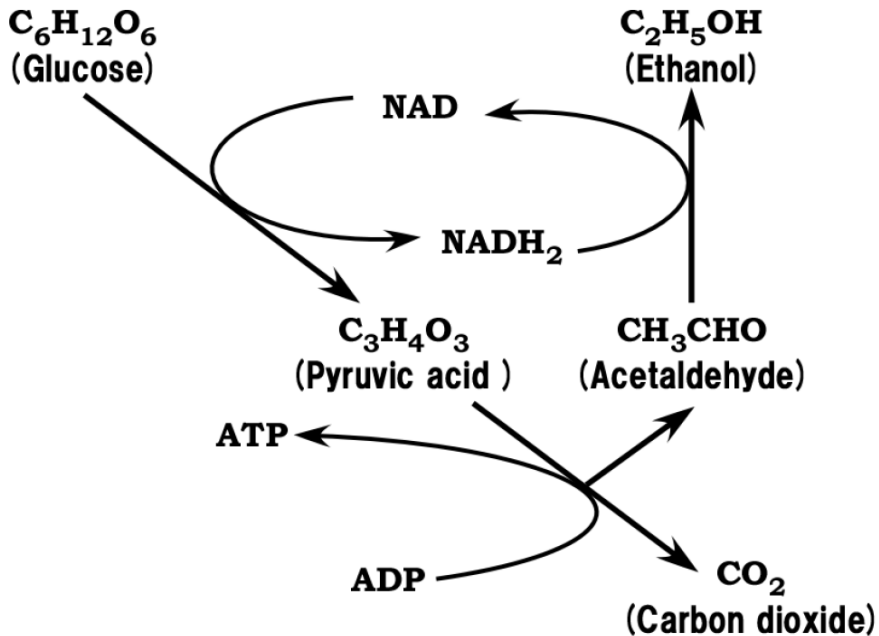

Figure 5. Ethanolic fermentation metabolism chart

The way to manufacture bioethanol is basically the same as that of liquor. Generally, saccharinity material such as sugar and starchy material such as rice and corn are saccharified (Figure 5-7), fermented and distilled till absolute ethanol whose alcoholicity is over 99.5%. It is technically possible to manufacture ethanol from cellulosic material such as rice straw or wood remains.

### 3.2.2. How to produce bio-ethanol:

- Materials

Sugarcane stems 5kg

Dry yeast, 15g

- Items

Brix meter, 5L flask, Dimroth condenser, Liebig condenser, Stick, Beaker

Cloth filter

1. Fermentation method
2. Mill juice out of Sugarcane stems. (about 3L of juice)
3. The juice is filtered out impurities.
4. Measurement Brix of juice.
5. Dry yeast is added to juice, the rate of 6g/L.
6. It keeps in the flask which sealed except the vent.
7. A cover is opened one day and once, then juice and dry yeast mixes so that air may enter with stick.
8. It continues until Brix becomes fixed.
9. Distillation method (Fig. 8)
10. Fermented juice is filtered out sediment.
11. It heats to boiling point in distiller.
12. Dimroth condenser is kept warm (about 70 degree) with hot water which is made to circulate by a pump.
13. Allihn condenser cools with tap water (about 20 degree).
14. Bio-ethanol which falls from the point of a allihn condenser is caught with beaker on ice.

### 3.2.3. Qualitative analysis for ethanol

Iodoform test on cold is special test for ethanol as the following: I ml ethanol layer mix with iodide and sodium hydroxide after that, the presence of yellow crystal and iodoform odor produced, this meaning presence of ethanol.

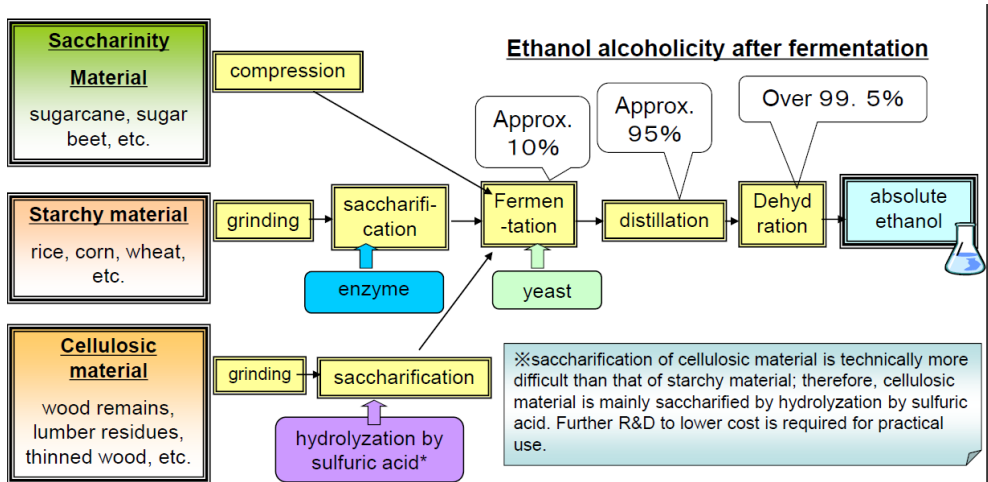

Figure 6. Production of absolute ethanol from Saccharinity, Starch and Cellulosic materials

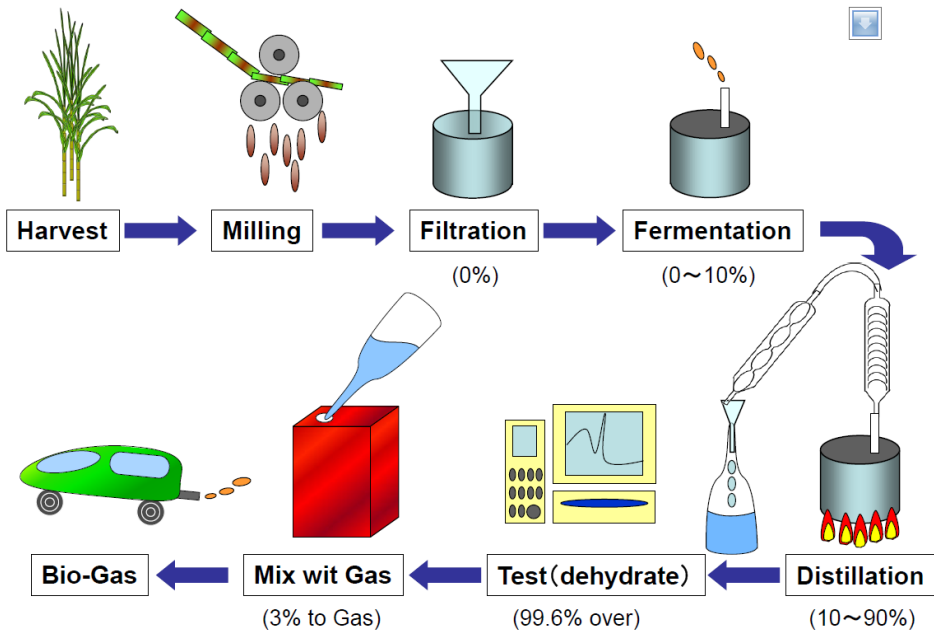

Figure 7. The main steps of bioethanol production from Starchy and cellulosic materials (Masami YASUNAKA / JIRCAS)

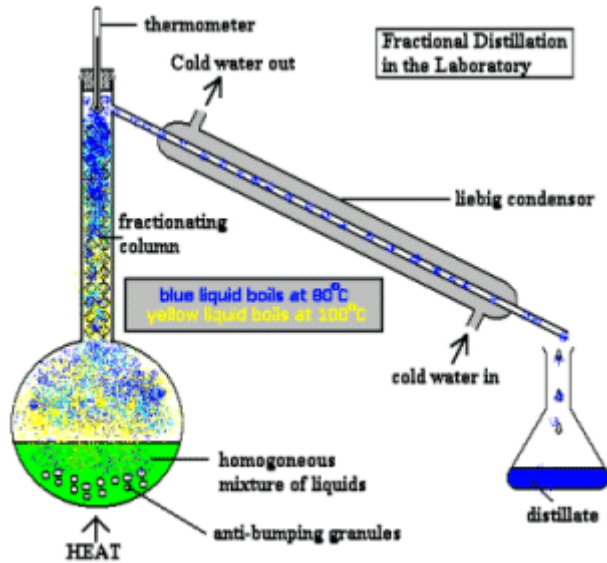

Figure 8. The distillation process for ethanol production.

### 3.2.4. Quantitative ethanol determination

#### 3.2.4.1. Direct injected GC method

Beverage sample solution (0.5 mL) was dispensed into an 1-mL capped sample vial, and then 5 mL of 1% internal standard solution (equivalent to 50 mg) was added. After mixing, 0.1  $\mu\text{L}$  of the sample solution was injected directly into a GC or GC/MS (Figure 9) with syringe (Anonymous. 1992; Collins et al., 1997).

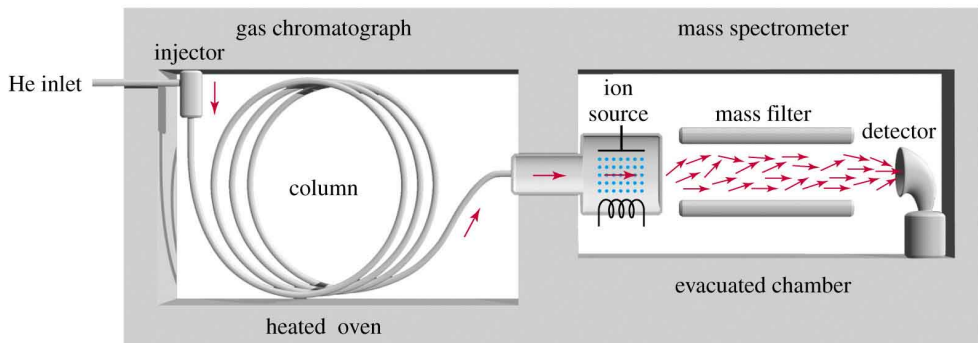

Figure 9. The GC/MS used for determination of ethanol.

#### 3.2.4.2. Dichromate oxidation method

Beverage sample solution (1-5 mL) was steam distilled to obtain alcoholic eluate (> 50 mL), and then oxidized with acidified dichromate. The excessive potassium dichromate was then titrated with ferric oxide. The ethanol content in beverage sample could be obtained by calculating the volume difference of potassium dichromate consumption between sample solution and control solution (Anonymous. 1992; Collins et al., 1997).

#### 3.2.4.3. Distillation-hydrometric method

Alcoholic volatile compounds in beverage samples were separated by distillation, and the gravity of the distillate was measured by hydrometer. The ethanol content was then converted (Anonymous. 1992; Collins et al., 1997).

### 3.3. Biogas (bio-methane) extraction

Methane fermentation is a versatile biotechnology capable of converting almost all types of polymeric materials to methane and carbon dioxide under anaerobic conditions. This is achieved as a result of the consecutive biochemical breakdown of polymers to methane and carbon dioxide in an environment in which varieties of microorganisms which include fermentative microbes (acidogens); hydrogen-producing, acetate-forming microbes (acetogens); and methane-producing microbes (methanogens) harmoniously grow and produce reduced end-products (Fig. 10-11). Anaerobes play important roles in establishing a stable environment at various stages of methane fermentation.

Methane fermentation offers an effective means of pollution reduction, superior to that achieved via conventional aerobic processes. Although practiced for decades, interest in anaerobic fermentation has only recently focused on its use in the economic recovery of fuel gas from industrial and agricultural surpluses.

The biochemistry and microbiology of the anaerobic breakdown of polymeric materials to methane and the roles of the various microorganisms involved are discussed here. Recent progress in the molecular biology of methanogens is reviewed, new digesters are described and improvements in the operation of various types of bioreactors are also discussed.

Methane fermentation is the consequence of a series of metabolic interactions among various groups of microorganisms. A description of microorganisms involved in methane fermentation, based on an analysis of bacteria isolated from sewage sludge digesters and from the rumen of some animals,. The first group of microorganisms secretes enzymes which hydrolyze polymeric materials to monomers such as glucose and amino acids, which are subsequently converted to higher volatile fatty acids,  $H_2$  and acetic acid (Fig. 10). In the second stage, hydrogen-producing acetogenic bacteria convert the higher volatile fatty acids *e.g.*, propionic and butyric acids, produced, to  $H_2$ ,  $CO_2$ , and acetic acid. Finally, the third group, methanogenic bacteria convert  $H_2$ ,  $CO_2$ , and acetate, to  $CH_4$  and  $CO_2$  (Nagai et al., 1986).

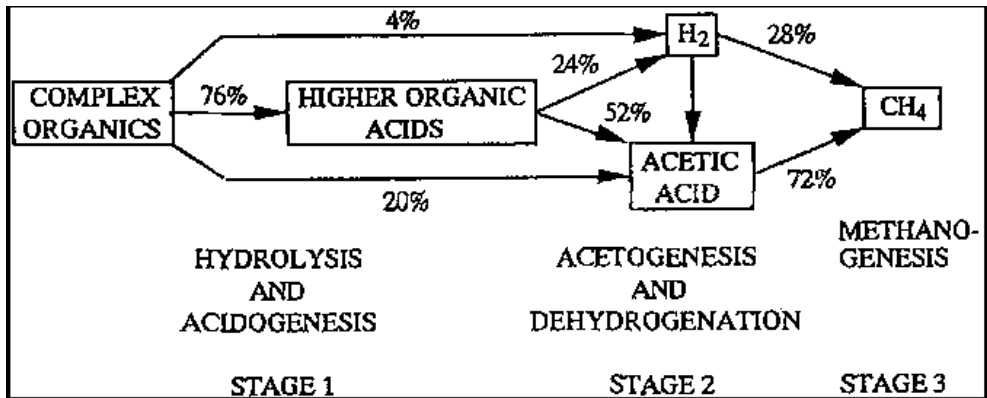

Figure 10. The main steps for production of methane gas

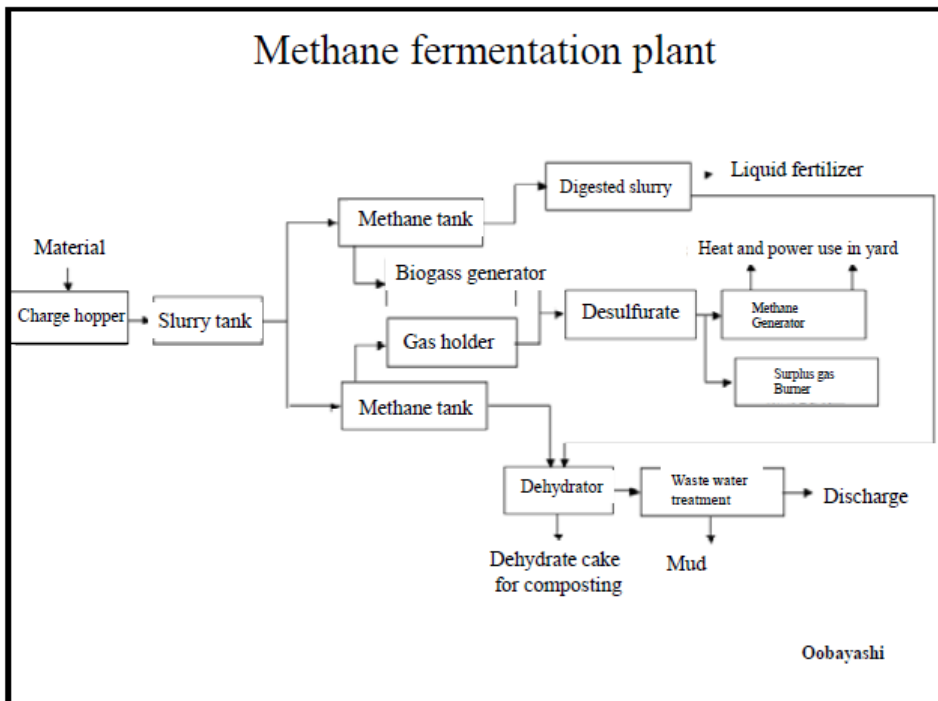

Figure 11. The principles methods for biomethane production

### 3.4. Determination of methane concentration

Methane will be measured on the gas chromatogram (Figure 9) using a FID (flame ionization) detector.

*Note, unless you want smelly hands, it is recommended that you wear gloves. A lab coat is recommended for similar reasons.*

- Using a 20 ml syringe connected to a 2-way stopcock, collect a little more than 5 ml of water from a port on your Winogradsky column.
- With the syringe pointing up, remove any air (tapping the sides of the syringe) and expel any extra water so that the final liquid volume in the syringe is 5 ml. Do this over a sink.
- Now, draw in 15 ml of air into the syringe so that the total air+water volume in the syringe is 20 ml. Close the stopcock.
- Shake the syringe to equilibrate the methane between the air and water.
- With the syringe pointing down, eject all the water from the syringe into the sink and close the stopcock. Try to get all the water out, but leave at least 10 ml of gas in the syringe
- We will now move to the GC lab in Starr 332 to measure methane.
- Repeat the above procedure for each of the ports on your Winogradsky column.

### 3.5. Calculations

To assist in plotting up results, measure the distance from the top of the sediment-water interface to each of the ports on the Winogradsky column, with distance to the ports in the sediment as positive and those in the water column negative. Also, measure the distance from the sediment-water interface to the surface of the water and the bottom of the sediments.

### 3.6. Methane concentration calculation

- From the standards, determine the concentration of methane in ppmv. Use the ideal gas law to determine the number of moles of methane in the 15 ml gas volume:

$$n = \frac{PV}{RT} = \frac{\frac{\text{ppm}}{10^6} \frac{15}{1000}}{(0.08205)(293)} \quad (1)$$

## 4. Physico-chemical parameters of extracted biofuel

### 4.1. Biodiesel

Most of the physical and chemical properties of the obtained methyl esters were determined by methods listed in JUS EN 14214:2004 standard [JUS EN 14214:2004] equivalent to EN 14214:2003,

which defines requirements and test methods for fatty acid methyl esters (FAME) to be used in diesel engine. It must be emphasized that the characterization of crude methyl esters (i.e. those obtained before the purification) was not performed as it is well known fact that such raw products represent mixtures that were not in compliance with the strict restrictions for alternative diesel fuels, as it contains glycerol, alcohol, catalyst, mono- and diglycerides besides fatty acid esters. Measurements of the density at 15 °C by hydrometer method and of the kinematic viscosity at 40 °C were carried out according to JUS EN ISO 3675:1988 and JUS ISO 3104:2003, respectively. The acid value (Av) was determined by titration in accordance to EN 14104:2003; the iodine value was obtained by Hannus method (EN 14111:2003) this property has been also previously used for the biodiesel characterization [Karaosmanog et al., 1996; Šiler-Marinkovic et al., 1998]. The method for the cetane index (CI) estimation based on the saponification (Sv) and iodine (Iv) values was previously described [Krisnangkura, 1986] as simpler and more convenient than experimental procedure for the cetane number determination utilizing a cetane engine (EN ISO 5165:1998). The Krisnangkura's equation [Krisnangkura, 1986] used for CI calculation was as follows:  $CI = 46.3 + 5458/Sv - 0.225 Iv$ . The cloud point of MEs was determined according to ASTM D-2500 and Total sulfur content according to ASTM D-4294, Copper strip corrosion at 100 °C according to ASTM D-130. The methyl ester composition was obtained by gas chromatograph equipped with DB-WAX 52 column (Supelco) and flame ionization detector. All the properties of frying oils as example were analyzed in two replicates and the final results given below were obtained as the average values (Table 3).

#### 4.1.1. Density at 15 °C

It is known that biodiesel density mainly depends on its methyl esters content and the remained quantity of methanol (up to 0.2% m/m according to JUS EN 14214 [JUS EN 14214:2004]); hence this property is influenced primarily by the choice of vegetable oil [Mittelbach, 1996], and in some extent by the applied purification steps. The mean density value of produced biodiesel was 0.90 g/cm<sup>3</sup>, while this value was more than Egyptian diesel (0.82-0.87g/cm<sup>3</sup>). but met the density value specified by JUS EN 14214 [JUS EN 14214:2004] to be in the range 0.860–0.900 g/cm<sup>3</sup> at 15 °C. This property is important mainly in airless combustion systems because it influences the efficiency of atomization of the fuel [Felizardo et al., 2006].

#### 4.1.2. Kinematic viscosity at 40 °C

Even more than density, kinematic viscosity at 40 °C is an important property regarding fuel atomization and distribution. With regard to the kinematic viscosities that were in the range from 32.20 to 48.47 mm<sup>2</sup>/s, the feedstocks differed among themselves significantly. The viscosities of MEs were much lower than their respective oils (about 10 times) and they met the required values that must be between 3.5 and 5.0 mm<sup>2</sup>/s [JUS EN 14214:2004]. Comparing our MEs, the increase of the viscosities was observed more than Egyptian diesel, EN14214 and D-6751 (14.3, 7, 5 and 6 respectively) as shown in Table (3). However, the kinematic viscosity at 100 °C of MEs produced from frying oil was met the viscosity range of Egyptian diesel, EN14214 and D-6751 (4.3, 7, 5 and 6 respectively). Predojevic (2008).



#### 4.1.3. Acid value

The acid value measures the content of free acids in the sample, which have influence on fuel aging. It is measured in terms of the quantity of KOH required to neutralize sample. The base catalyzed reaction is reported to be very sensitive to the content of free fatty acids, which should not exceed a certain limit recommended to avoid deactivation of catalyst, formation of soaps and emulsion [Sharma et al., 2008, Meher et al., 2004]. The feedstock acid values obtained in this study differed significantly ranging from 1.86 to 3.31 mg KOH/g oil. Thus, in the light of the previous discussion on the requirements for the feedstock acid values, it could be concluded that frying oil had the values above the recommended 2 mg KOH/g. However, these values did not turn out to be limiting for the efficiency of the applied two-stage process, as it will be discussed along to the obtained product yields and purity later on. Acid values of MEs were less than 0.5 mg KOH/g specified as the maximum value according to *JUS EN14214* (Table 4), Sharma et al. (2008) reviewed the literature and found that acid value of the feedstock for alkaline transesterification has to be reduced to less than 2 mg KOH/g (i.e. 1%), while only few examples of transesterification with feedstock acid value of up to 4.0 mg KOH/g (i.e. 2%) were found. They also reported that when waste cooking oil is used as feedstock, the limit of free fatty acids is a bit relaxed and the value a little beyond 1% (i.e. 2 mg KOH/g) did not have any effect on the methyl ester conversion. Acid values of MEs produced from frying oil was 1.16 mgKOH/g when compared with 0.5 mg KOH/g specified as the maximum value according to *JUS EN14214* [*JUS EN 14214:2004*].

#### 4.1.4. Iodine value

The iodine value of the feedstocks used in this study, which is a measure of unsaturation degree, was in the range of 70-78 mg I<sub>2</sub>/100 g. According to *JUS EN 14214* [*JUS EN 14214:2004*], MEs used as diesel fuel must have an iodine value less than 120 g I<sub>2</sub> per 100 g of sample. Methyl esters obtained in this study had iodine value in the range 72-80g I<sub>2</sub>/100 g and this finding is in accordance to the fatty acid composition, i.e. the calculated total unsaturation degree of MEs (see Table 4). Iodine value depends on the feedstock origin and greatly influences fuel oxidation tendency. Consequently, in order to avoid oxidation.

#### 4.1.5. Saponification value

The saponification value represents milligrams of potassium hydroxide required to saponify one gram of fat or oil. The obtained results indicated that in general, esters had higher saponification values than the corresponding oils. Saponification values of the feedstocks and products analyzed here, ranged from 199 to 207 mg KOH/g oil. However, knowing that a triglyceride has 3 fatty acid chains associated and each triglyceride will give 3 methyl esters, stoichiometrically it may be expected that the same amount of fatty acid carbon chain in neat feedstock oil and the biodiesel will react with the same amount of KOH giving the soaps, i.e. their saponification values will be the same. But, could this assumption be also applied on the waste frying oils knowing that their properties differ significantly from the neat oils as a consequence of cyclization, polymerization and degradation of fatty acids.

#### 4.1.6. Cetane index

Krisnagkura [1986] proposed the equation for the estimation of cetane index (CI) based on the saponification and iodine values, recommending not to be used for oils, only for methyl esters. Namely, it has been previously documented that despite the fact that triglycerides and fatty acid methyl esters have similar saponification and iodine values, like it was obtained in this study too, cetane indexes of oils are generally much lower than those of methyl ester derivatives. Thus, discussion on CI of frying oil will not be made. In this work, the CI value was 38 and this value less than the CI of Egyptian diesel, EN 14214 and D-6751 (55, 51 and 47 respectively). Šiler-Marinković and Tomašević [1998] also used CI for the characterization of methyl esters produced from crude frying oils, and the estimated values were from 49.7 to 50.9. As an alternative to cetane number, cetane index is also an indicator of ignition quality of the fuel and is related to the time that passes between injection of the fuel into the cylinder and onset of ignition [Knothe, 2005].

Test	Produced Biodiesel	Egyptian Diesel oil	Biodiesel (EN14214)	Biodiesel D-6751
Flash point °C	202	"/> 55	"/> 101	"/> 130
Density g/cm <sup>3</sup> @ 15.56 °C	0.9055	0.82-0.87	0.86-0.9	----
Kinematic Viscosity cSt @ 40 °C	8.38	1.6-7	3.5-5	1.9-6
Kinematic Viscosity cSt @ 100 °C	4.34	---	----	----
Total acid number (mg KOH/g)	0.48	Nil	< 0.5	< 0.8
Cloud point °C	3	---	- 4	----
Pour point °C	0	4.5-15	----	----
Initial boiling point IBP °C	229	----	----	
Cetane number	63.8	Min. 55	"/> 51	"/> 47
Calorific value MJ/Kg	38.54	Min. 44.3	32.9	----
Total S wt%	0.12	Max. 1.2	< 0.01	< 0.05
Ash content wt%	0.002	Max. 0.01	0.02	< 0.02
Carbon residue wt%	0.63	Max.0.1	< 0.03	< 0.05
Copper strip corrosion @ 100°C	1a	1a	Class 1	No. 3 Max.
Water content wt%	0.08	Max. 0.15	< 0.05	0.05
Iodine number mg I <sub>2</sub> /100 g	60	---	120	---

**Table 3.** Physicochemical properties for produced biodiesel compared to the Egyptian standards of petro-diesel fuel and two international biodiesel standards

#### 4.1.7. Fatty acid composition

As can be observed from Table 5, regardless of the fatty acid profiles were observed in the biodiesel produced from frying oil, consisting mainly of methyl esters of oleic (C 18:1), palmitic (C 16:0), and stearic (C 18:0) acids (30.60, 3.0 and 66.40 % respectively) and 2.8 % unknown fatty acid. these results are in agreement with the results obtained by Predojvic (2008) who reported that, fatty acid profiles were observed in the biodiesels produced from sun flower oil consisting mainly of methyl esters of oleic (C 18:1), palmitic (C 16:0), linoleic (C 18:2) and stearic (C 18:0) acids.

Parameters	Feedstock	Produced biodiesel
<b>Acid value</b> mg KOH/g	5.1	0.48
<b>Iodine value</b> mg I <sub>2</sub> /g	62.0	60.0
<b>Saponification value</b> mg KOH/g	199.5	207.0

**Table 4.** Some chemical properties of waste cooking oil (WCO) used as feedstock for methyl esters preparation and produced biodiesel

Fatty acid ester	Carbon number chain	Wt%	Molecular formula
<b>Palmetic</b>	16	3.00	C <sub>16</sub> H <sub>32</sub> O <sub>2</sub>
<b>Stearic</b>	18	66.40	C <sub>18</sub> H <sub>36</sub> O <sub>2</sub>
<b>Oleic</b>	18	30.60	C <sub>18</sub> H <sub>34</sub> O <sub>2</sub>

**Table 5.** Composition of biodiesel obtained by transesterification of WCO using GC

## 4.2. Bioethanol

### 4.2.1. Property of ethanol

Melting point: -114.15

Boiling point: 78.3

Molecular formula: C<sub>2</sub>H<sub>5</sub>OH

Molecular weight: 46.07

Specific gravity: 0.789

Toxicity: Get intoxicated

### 4.3. Biomethane

#### 4.3.1. Gas properties

##### 4.3.1.1. Molecular weight

- Molecular weight : 16.043 g/mol

##### 4.3.1.2. Solid phase

- Melting point : -182.5 °C
- Latent heat of fusion (1,013 bar, at triple point) : 58.68 kJ/kg

##### 4.3.1.3. Liquid phase

- Liquid density (1.013 bar at boiling point) : 422.62 kg/m<sup>3</sup>
- Liquid/gas equivalent (1.013 bar and 15 °C (59 °F)) : 630 vol/vol
- Boiling point (1.013 bar) : -161.6 °C
- Latent heat of vaporization (1.013 bar at boiling point) : 510 kJ/kg

##### 4.3.1.4. Critical point

- Critical temperature : -82.7 °C
- Critical pressure : 45.96 bar

##### 4.3.1.5. Gaseous phase

- Gas density (1.013 bar at boiling point) : 1.819 kg/m<sup>3</sup>
- Gas density (1.013 bar and 15 °C (59 °F)) : 0.68 kg/m<sup>3</sup>
- Compressibility Factor (Z) (1.013 bar and 15 °C (59 °F)) : 0.998
- Specific gravity (air = 1) (1.013 bar and 21 °C (70 °F)) : 0.55
- Specific volume (1.013 bar and 21 °C (70 °F)) : 1.48 m<sup>3</sup>/kg
- Heat capacity at constant pressure (C<sub>p</sub>) (1 bar and 25 °C (77 °F)) : 0.035 kJ/(mol.K)
- Heat capacity at constant volume (C<sub>v</sub>) (1 bar and 25 °C (77 °F)) : 0.027 kJ/(mol.K)
- Ratio of specific heats (Gamma:C<sub>p</sub>/C<sub>v</sub>) (1 bar and 25 °C (77 °F)) : 1.305454
- Viscosity (1.013 bar and 0 °C (32 °F)) : 0.0001027 Poise
- Thermal conductivity (1.013 bar and 0 °C (32 °F)) : 32.81 mW/(m.K)

#### 4.3.2. Miscellaneous

- Solubility in water (1.013 bar and 2 °C (35.6 °F)) : 0.054 vol/vol
- Autoignition temperature : 595 °C

## 5. Biofuel blending

It is important that when you are purchasing fuel you make sure it is high quality by meeting all ASTM specifications. Fuel that is off specification on just one of the ASTM standards can not only cause serious engine problems, but it can void engine warranties if it is determined that the fuel caused damage. This can cause unnecessary costly repairs for vehicles/equipment. To review specifications for diesel fuel, biodiesel and biodiesel blends, see the specifications in the Appendix. In an effort ensure that producers and marketers operate in a manner consistent with proper specifications, the National Biodiesel Accreditation Commission created the BQ-9000 program in 2005. This voluntary program establishes quality systems for producers and marketers of biodiesel in the areas of storage, sampling, testing, blending, shipping, distribution and fuel management practices. If purchasing B100 or a biodiesel blend, ask if the biodiesel is from a BQ-9000 biodiesel producer/marketer. If you are unable to get fuel from a BQ-9000 producer/marketer, the next best thing is to verify with your supplier that the fuel meets all ASTM specifications.

In most cases the blending process takes place right at the terminal rack by a process called in-line blending. This is the preferred method because it ensures complete blending. In-line blending occurs when warm biodiesel is added to a stream of diesel fuel as it travels through a pipe or hose in such a way that the biodiesel and diesel fuel become thoroughly mixed by the turbulent movement. This product is sold directly to customers, petroleum jobbers or a distribution company for sale to customers.

The blend level (percentage of biodiesel in the biodieseldiesel mixture) determines many important characteristics of the blended fuel. A higher-than-specified level of biodiesel may exceed the engine manufacturer's recommended limitation, compromising the engine performance. A lower blend level of biodiesel may reduce the expected benefits, such as fuel lubricity and tail pipe emission. In addition, cloud point and pour point of biodiesel are usually higher than that of diesel fuel, and a higher blend level makes the fuel unsuitable or difficult to use in cold weather conditions. Engine injection timing can be adjusted based on the blend level in order to improve the engine emission and performance (Tat and Van Gerpen, 2003).

It has been reported that the actual biodiesel content of blended biodiesel fuel sold at gas stations can be significantly different from the nominal blend level. A 2% nominal blend has been found to actually contain anywhere from 0% to 8% biodiesel (Ritz and Croudace, 2005). There are several reasons why the actual blend level may differ from the specified level. For instance, if biodiesel is blended at a temperature less than 10°F above its cloud point, it will not mix well with diesel, causing a rich mixture in one portion of the tank and a lean mix-

ture in another portion (NBB, 2005). Other reasons for the discrepancy may include profit-driven fraud and involuntary mixing of diesel into the blend to lower the overall blend level of biodiesel. Biodiesel is usually sold at a higher price than diesel fuel; therefore, the price of the fuel is dependent on the blend level. Knothe (2001) has shown that near-infrared (NIR) spectroscopy and nuclear magnetic resonance (NMR) can be used to detect biodiesel blend levels. However, the NMR method depends on the biodiesel fatty acid profile; hence, knowledge of the biodiesel feedstock is required before this method can be used. In addition, using NMR only to detect blend level may not be cost effective. For NIR spectroscopy, Knothe suggested using wavelengths around 1665 nm or 2083 to 2174 nm. Since aromatic compounds produce strong and sharp infrared bands due to their relatively rigid molecular structure and diesel fuels have varying amounts of aromatics between 20% and 35% (Song et al., 2000), the absorbance of a blend may not directly correlate to the percentage of biodiesel. The absorbance is defined as the logarithm of the radiation intensities ratio, that is, before and after being absorbed by a sample.

Diesel fuel is distilled from crude petroleum, which is composed primarily of hydrocarbons of the paraffinic, naphthenic, and aromatic classes. Each class contains a very broad range of molecular weights. One of the features of diesel fuel is the presence of 20% to 35% aromatic compounds by weight. Aromatics are a class of hydrocarbons that are characterized by a stable chemical ring structure. They are determined primarily by the composition of the crude oil feed, which is usually selected based on considerations of availability and cost (Chevron, 2006). On the other hand, biodiesel is a mixture of fatty acid esters. Fatty acids with 16 to 22 carbon chain lengths are predominant in oils and fats. The resulting mixture of fatty acid esters depends on the kind of feedstock used. Neat biodiesel contains essentially no aromatic compounds.

The presence of aromatics in diesel and their absence in biodiesel creates the possibility of distinguishing these two fuels using ultraviolet spectroscopy. Benzene, the simplest aromatic compound, has maximum absorption at 278 nm (Zawadzki et al., 2007). Biodiesel, which is esters of long-chain fatty acids when adequately diluted in *n*-heptane, has negligible absorbance compared to the aromatics at the same frequency. Hence, differences in biodiesel feedstocks will have a minimal impact on absorbance at this wavelength. The ultraviolet (UV) range between 200 and 380 nm is also referred to as near-UV. In general, light sources, filters, and detectors are less expensive for this vicinity of the spectrum than for IR at 8621 nm, as used by the CETANE 2000. Hence, near-UV spectroscopy may present a low-cost alternative method for biodiesel blend level sensing (Figure 12 and 13).

## 6. Material balance of biofuel product

Biomass conversion plant has many components which are connected each other. Material and energy flow among the components, therefore we should grasp the detail of the balance (Figures 13-16). If there is a choke point, the flow stagnation causes to the troubles of operation and low efficiency of the performance. (Masami UENO, University of Ruyku, Faculty of Agriculture, Okinawa, Japan).

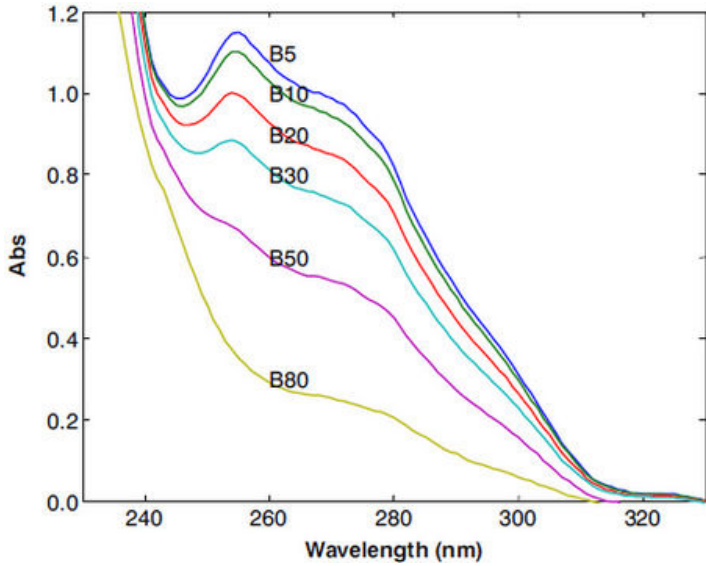

Figure 12. UV absorbance spectra of soy methyl ester and No. 2 diesel blend diluted 1:2915 in *n*-heptane.

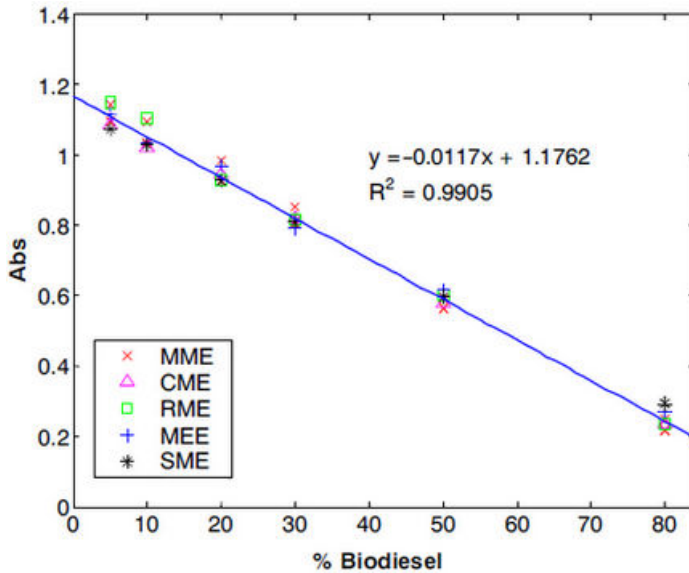

Figure 13. Absorbance of diluted biodiesel-diesel blends from different feedstocks at 260 nm wavelength (MME = mustard methyl esters, CME=canola methyl esters, RME = rapeseed methyl esters, MEE = mustard ethyl esters, and SME = soybean methyl esters).

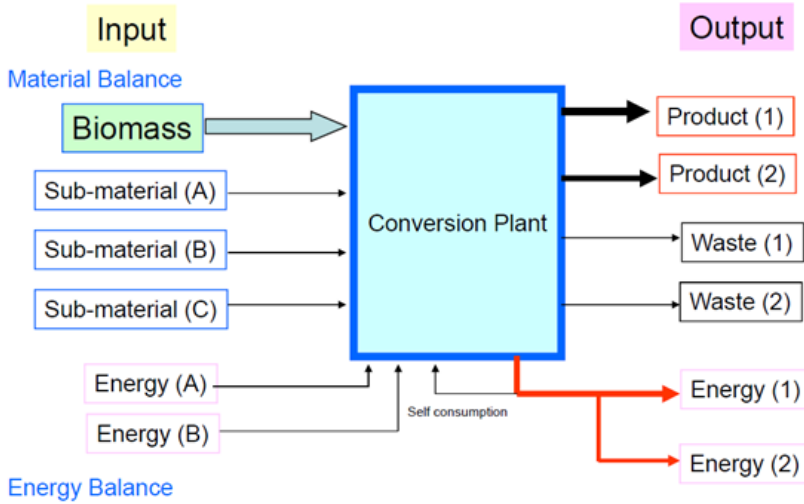

Figure 14. Material balance and energy balance.

### Material and Energy Balances in BDF production

Used cooking oil, Capacity; 5t/d

BDF( 5t/d)

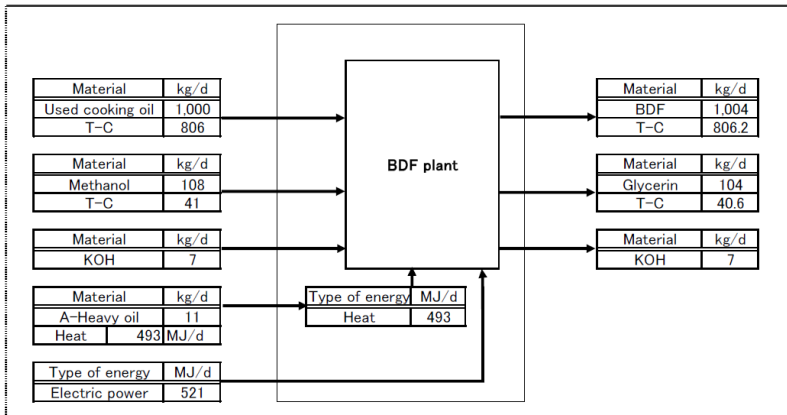

Figure 15. Material and energy balance in biodiesel fuel production



## Material and Energy Balances in Direct Combustion

Wood waste, Capacity; 50t/d

Direct combustion (50t/d)

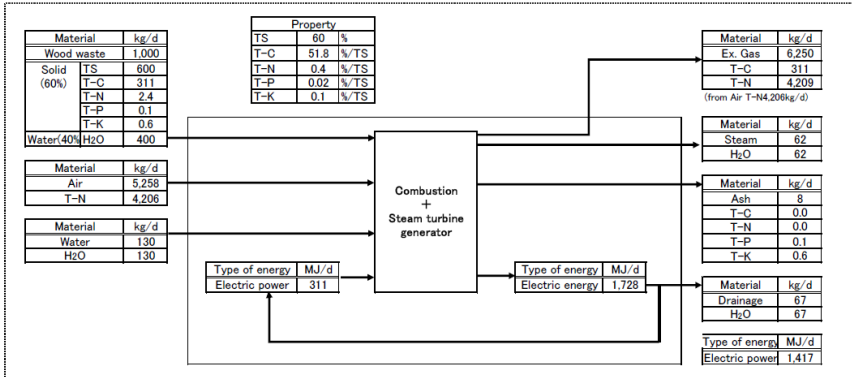

Figure 16. Material and energy balance in direct combustion

## Material and Energy Balances in RDF Production

Burnable waste, Capacity; 25t/d

RDF (25t/d)

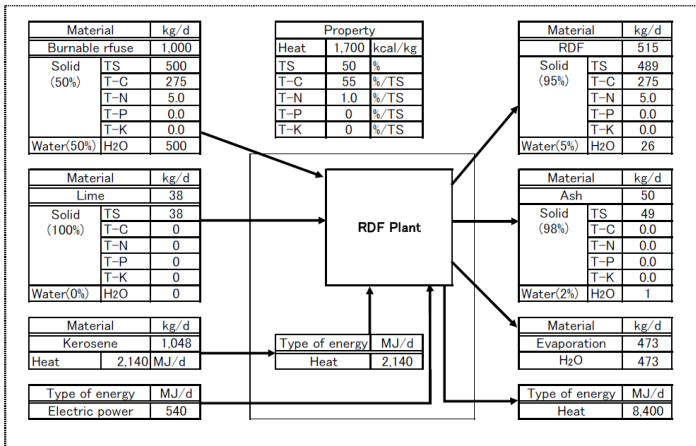

Figure 17. Material and energy balance in RDF production

## 7. Conclusion

The different kind of biomass considered as main source for biofuel (diesel-methane, ethanol, compost –etc). The cost of extraction and blending is very effective point for use of biomass in addition to ability for use of all part from biomass as multipurpose.

## Author details

Emad A. Shalaby

Biochemistry Dept., Facult. of Agriculture, University of Ruyku, Cairo University, Egypt

## References

- [1] Anonymous. 1992. Chapter 4-Alcohols. In Wine Analysis. Research Institute for Wines, Taiwan Tobacco & Wine Monopoly Bureau. pp. 1-7.
- [2] Chevron. 2006. Diesel fuels technical review. San Ramon, Cal.: Chevron Corp.
- [3] Collins, T. S., Miller, C. A., Altria, K. D. Waterhouse, A. L. 1997. Development of a rapid method for the analysis of ethanol in wines using capillary electrophoresis. *Am. J. Enol. Vitic.* 48: 280-284.
- [4] Dube MA.; A.Y. Tremblay, J. Liu, Biodiesel production using a membrane reactor, *Bioresour. Technol.* 98 (2007) 639–647.
- [5] Felizardo P, Neiva Correia MJ, Raposo I, Mendes JF, Berkemeier R, Bordado JM. Production of biodiesel from waste frying oils. *Waste Manage* 2006;26:487–94.
- [6] Hayyan , M., Mjalli , FS., Hashim, MA.; , lNashef, IA. (2010). A novel technique for separating glycerine from palm oil-based biodiesel using ionic liquids. *Fuel Processing Technology* 91 :116–120.
- [7] JUS EN 14214:2004. Automotive fuels. Fatty acid methyl esters (FAME) for diesel engines-requirements and test methods. Standardization Institute,Belgrade, Serbia.
- [8] Karaosmanog˘lu F, Cig˘izog˘lu KB, Tuter M, Ertekin S. Investigation of the refining step of biodiesel production. *Energ Fuel* 1996;10:890–5.
- [9] Krisnangkura K. A simple method for estimation of cetane index of vegetable oil methyl esters. *JAOCs* 1986;3:552–3.
- [10] Knothe, G. 2001. Determining the blend level of mixtures of biodiesel with conventional diesel fuel by fiber-optic near-infrared spectroscopy and H-1 nuclear magnetic resonance spectroscopy. *J. American Oil Chem. Soc.* 78(10): 1025-1028.

- [11] Ma F.; M.A. Hanna, Biodiesel production: a review, *Bioresour. Technol.* 70 (1999) 1–5.
- [12] Meher LC, Sagar DV, Naik SN. Technical aspects of biodiesel production by transesterification-a review. *Renew Sust Energy Rev* 2004;1–21.
- [13] Mittelbach M. Diesel fuel derived from vegetable oils, VI: specifications and quality control of biodiesel. *Bioresour Technol* 1996;56:7–11.
- [14] Nagai, S. and Nishio, N., In "Handbook of Heat and Mass Transfer, vol. 3 Catalysis, Kinetics and Reactor Engineering" Ed. Cheremisinoff, N.P., 701-752 (1986) Gulf Publishing Corn., Houston, London, Paris, Tokyo.
- [15] NBB. 2005. Biodiesel cold weather blending study. Jefferson City, Mo.: National Biodiesel Board.
- [16] Predojevic, ZJ. (2008). The production of biodiesel from waste frying oils: A comparison of different purification steps. *Fuel* 87 : 522–3528.
- [17] Ritz, G. P., and M. C. Croudace. 2005. Biodiesel or FAME (fatty acid methyl ester): Mid-infrared determination of ester concentration in diesel fuel. Houston, Tex.: Petroleum Analyzer Company (PAC).
- [18] Shalaby, EA (2011). Algal Biomass and Biodiesel Production, *Biodiesel - Feedstocks and Processing Technologies*, Margarita Stoytcheva and Gisela Montero (Ed.), ISBN: 978-953-307-713-0, InTech, Available from: <http://www.intechopen.com/articles/show/title/algal-biomass-and-biodiesel-production>
- [19] Shalaby, EA and El-Gendy. NS. (2012). Two steps alkaline transesterification of waste cooking oil and quality assessment of produced biodiesel. *International Journal of Chemical and Biochemical Sciences. IJCBS*, 1(2012): 30-35.
- [20] Sharma YC, Singh B, Upadhyay SN. Advancements in development and characterization of biodiesel: a review. *Fuel* 2008;87:2355–73.
- [21] Šiler-Marinković SS, Tomašević VA. Transesterification of sunflower oil in situ. *Fuel* 1998;77:1389–91.
- [22] Song, C., C. S. Hsu, and I. Mochida. 2000. Introduction to chemistry of diesel fuel. In *Chemistry of Diesel Fuels*, 1-60. New York, N.Y.: Taylor and Francis.
- [23] Tat, M. E., and J. H. Van Gerpen. 2003. Biodiesel blend detection with a fuel composition sensor. *Applied Eng. in Agric.* 19(2): 125-131.
- [24] Tomasevic V. A. and Siler-Marinkovic S. S. "Methanolysis of used frying oil" *Fuel Process Technol.* 81: 1-6 (2003).
- [25] Vicente G.; M. Martínez, J. Aracil, Optimisation of integrated biodiesel production. Part I. A study of the biodiesel purity and yield, *Bioresour. Technol.* 98 (2007). 1724–1733.

- [26] Zawadzki, A.; Shrestha, D. S.; He, B. (2007). Biodiesel Blend Level Detection Using Ultraviolet Absorption Spectra. *American Society of Agricultural and Biological Engineers*, 50(4): 1349-1353.