

# 2 CHAPTER

## Bolted Connections

---

A bolt is a metal pin with a head formed at one end and shank threaded at the other in order to receive a nut. On the basis of load transfer in the connection bolts are classified as:

- (a) Bearing Type
- (b) Friction Grip Type

There are two types of bearing type bolts, namely,

- (i) Unfinished or Black Bolts.
- (ii) Finished or Turned Bolts.

The shanks of black bolts are unfinished, i.e., rough as obtained at the time of rolling, while turned bolts are obtained by turning hexagonal shank to circular shape. The bolt hole diameter is only 1.5 mm larger than that of the shank in case of turned bolt. These bolts are used in special jobs like connecting machine parts subject to dynamic loadings. For black bolts, diameter of bolt hole is larger and are used in most of the work. A black bolt is represented as M16, M20, etc. which means black bolt of nominal diameter 16 mm, black bolt of nominal diameter 20 mm, etc.

### 2.1 TERMINOLOGY

The following terms used in bolted connection should be clearly understood [Ref. Fig. 2.1(a)]:

1. **Pitch of the Bolts ( $p$ ):** It is the centre-to-centre spacing of the bolts in a row, measured along the direction of load.
2. **Gauge Distance ( $g$ ):** It is the distance between the two consecutive bolts of adjacent rows and is measured at right angles to the direction of load.
3. **Edge Distance ( $e$ ):** It is the distance of bolt hole from the adjacent edge of the plate.

where  $\gamma_{ml}$  = partial safety factor at ultimate stress = 1.25

$f_u$  = ultimate stress of the material of plate

$A_n$  = net effective area at critical section

$$= \left[ b - nd_o + \Sigma \frac{P_{si}^2}{4g_i} \right] t$$

where  $b$  = width of plate

$t$  = thickness of thinner plate

$d_o$  = diameter of the bolt hole

$n$  = number of bolt holes

**Note:** If there is no staggering of the bolts,  $p_{si} = 0$  and hence,  $A_n = [b - nd_o] t$

## 2.3 DESIGN STRENGTH OF BEARING BOLTS

**(a) In Shear:** It is least of the following:

(i) Shear capacity (strength)

(ii) Bearing capacity (strength)

(i) *Shear capacity of bearing bolts* ( $V_{dsb}$ )

$$V_{dsb} = \frac{V_{nsb}}{\gamma_{mb}}$$

where  $\gamma_{mb}$  = partial safety factor of bolt

and  $V_{nsb}$  = nominal shear capacity of bolt

$$= \frac{f_{ub}}{\sqrt{3}} (n_n A_{nb} + n_s A_{sb})$$

where  $f_{ub}$  = ultimate tensile strength of bolt

$n_n$  = number of shear planes through threads

= 1 for each bolt.

$n_s$  = number of shear planes intercepting non-threaded portion of shank

= 1, for a bolt in double shear

= 0, for a bolt in single shear.

$A_{sh}$  = nominal shank area of the bolt

$A_{nb}$  = net shear area in threaded portion

i.e., 
$$T_{dh} = \frac{0.9 f_{ub} A_n}{\gamma_{mb}} \leq \frac{f_{yb} A_{sh}}{\gamma_{mo}}$$

where  $f_{yb}$  = yield stress of the bolt

$A_n$  = net area of the bolt at thread

$$= 0.78 \frac{\pi}{4} d^2 \text{ for ISO bolts.}$$

$A_{sh}$  = shank area of the bolt =  $\frac{\pi}{4} d^2$ .

## 2.4 DESIGN STRENGTH OF HSFG BOLTS IN SHEAR ( $V_{dsf}$ )

$$V_{dsf} = \frac{V_{nsf}}{\gamma_{mf}}$$

where  $\gamma_{mf} = 1.10$ , if slip resistance is designed at service load

= 1.25, if the slip resistance is designed at ultimate load.

and  $V_{nsf} = \mu_f n_e K_h F_o$

where  $\mu_f$  = coefficient of friction as specified in Table 20 (Clause 10.4.3) in IS 800-2007.

$n_e$  = number of effective interfaces offering frictional resistance to the slip.

[Note:  $n_e = 1$  for each bolt in lap joint and 2 for each bolt in double cover bolt joint]

$K_h = 1.0$  for fasteners in clearance hole

= 0.85 for fasteners in oversized and short slotted holes and for long slotted holes loaded perpendicular to the slot.

$F_o$  = minimum bolt tension at installation and may be taken as  $A_{nb} f_o$

$A_{nb}$  = net area of the bolt at threads

$$\left( 0.78 \frac{\pi}{4} d^2 \right)$$

$f_o$  = proof stress =  $0.7 f_{ub}$ .

### Note:

1. All the reduction factors specified for bearing bolted connection hold good for HSFG bolted connection also.
2. Since the bearing strength of HSFG bolts is greater than the plates, no check on bearing strength of the bolt is necessary.

### HSFG Bolt Strength in Tension ( $T_{df}$ )

$$T_{df} = \frac{0.9 f_{ub} A_n}{\gamma_{mb}} \leq \frac{f_{yb} A_{sh}}{\gamma_m}$$

$$\gamma_{mb} = 1.25, \gamma_m = 1.1$$

**Note:** In the design of HSFG bolts subjected to tensile forces additional force  $Q$  called prying forces is to be considered.

$$Q = \frac{l_v}{2l_c} \left( T_e - \frac{\beta \eta f_0 b_e t^4}{27l_c l_v^2} \right)$$

where

$Q$  = prying force

$2T_e$  = total applied tensile force

$l_v$  = distance from the bolt centre line to the toe of the fillet weld or to half the root radius for a rolled section

$l_c$  = distance between prying forces and bolt centre line and is the minimum of either the end distance or the value given by:

$$l_c = 1.1t \sqrt{\frac{\beta f_0}{f_y}}$$

$\beta$  = 2 for non-pretensioned bolts and 1 for pretensioned bolts

$\eta$  = 1.5

$b_e$  = effective width of flange per pair of bolts

$f_0$  = proof stress in consistent units

$t$  = thickness of end plate.

## 2.5 PRINCIPLES TO BE OBSERVED IN THE DESIGN

1. Design strength should be more than design load.
2. The centre of gravity of bolts should coincide with the centre of gravity of the connected members.
3. The length of connection should be kept as small as possible.
4. It should satisfy requirements specified in clause 10.2, regarding spacing, such as
  - a. Pitch shall not be less than 2.5  $d$ .
  - b. Minimum edge distance = 1.7  $d_o$ , in case of hand cut edges and 1.5  $d_o$  in case of rolled or machine cut edges.

5. Diameter of bolt hole for various bolts shall be taken as shown below:

diameter of bolt ( $d$ ) :            12   14   16   20   22   24   30   36

diameter of bolt hole ( $d_o$ ) :    13   15   18   22   24   26   33   39

6. Area of bolt at shank =  $\frac{\pi}{4} d^2$

Area of bolt at threads =  $0.78 \frac{\pi}{4} d^2$

7. Material properties of bolts.

Grade 4.6

$f_{yb} = 240$  MPa

$f_{ub} = 400$  MPa

Grade 4.8

$f_{yb} = 320$  MPa

$f_{ub} = 420$  MPa

Grade 5.6	$f_{yb} = 300 \text{ MPa}$	$f_{ub} = 500 \text{ MPa}$
Grade 5.8	$f_{yb} = 400 \text{ MPa}$	$f_{ub} = 520 \text{ MPa}$

**Example 2.1** Design a lap joint to connect two plates each of width 100 mm, if the thickness of one plate is 12 mm and the other is 10 mm. The joint has to transfer a working load of 100 kN. The plates are of  $f_e$  410 grade. Use bearing type of bolts and draw connection details.

**Solution:** Using M16 bolts of grade 4.6,

$$d = 16 \text{ mm} \quad d_o = 18 \text{ mm} \quad f_{ub} = 400 \text{ N/mm}^2$$

Since it is a lap joint, the bolt is in single shear, the critical section being at the roots of the thread of the bolts.

∴ Nominal strength of a bolt in shear

$$\begin{aligned} V_{nsb} &= \frac{f_{ub}}{\sqrt{3}} \left( 1 \times 0 + 0.78 \frac{\pi}{4} d^2 \right) \\ &= \frac{400}{\sqrt{3}} \times 0.78 \times \frac{\pi}{4} \times 16^2 \\ &= 36218 \text{ N} \end{aligned}$$

∴ Design strength of a bolt in shear

$$V_{dsb} = \frac{V_{nsb}}{\gamma_{mb}} = \frac{36218}{1.25} = 28974 \text{ N}$$

Minimum pitch to be provided =  $2.5 d = 2.5 \times 16 = 40 \text{ mm}$

Minimum edge distance =  $1.5 d_o = 1.5 \times 18 = 27 \text{ mm}$

Provide  $p = 40 \text{ mm}$  and  $e = 30 \text{ mm}$ .

Strength in bearing:

$$k_b \text{ is least of } \frac{30}{3 \times 18}, \frac{40}{3 \times 18} - 0.25, \frac{400}{410} \text{ and } 1.0$$

$$\text{i.e.,} \quad k_b = 0.4907$$

Now, thickness of thinner plate = 10 mm,  $f_u = 400 \text{ N/mm}^2$

∴ Normal bearing strength of a bolt

$$\begin{aligned} V_{npb} &= 2.5 k_b dt f_u \\ &= 2.5 \times 0.4907 \times 16 \times 10 \times 400 \\ &= 78512 \text{ N} \end{aligned}$$

∴ Design strength of M16 bolts

$$= 28974 \text{ N}$$

Working (nominal load) = 100 kN.

∴ Design load =  $100 \times 1.5 = 150 \text{ kN}$ .

$$\text{Hence, no. of bolts required} = \frac{150 \times 1000}{28974} = 5.18$$

Provide 6 bolts. They may be provided as shown in Fig. 2.3.

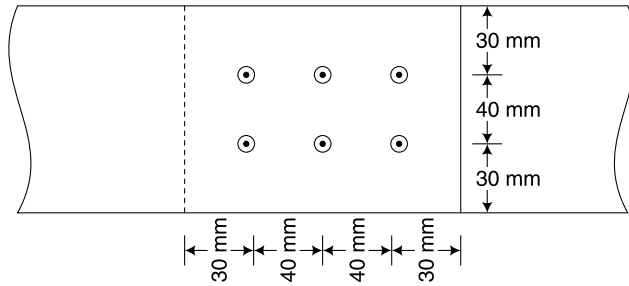

Fig. 2.3

**Check for the Strength of Plate**

$$T_{dn} = \frac{0.9 A_n f_u}{\gamma_{ml}}$$

There are two holes along the critical section,

$$\begin{aligned} \therefore T_{dn} &= \frac{0.9 \times (100 - 2 \times 18) \times 10 \times 410}{1.25} \\ &= 188928 \text{ N} = 188.928 \text{ kN} > 150 \text{ kN}. \end{aligned}$$

Hence safe.

**Example 2.2** Design a single bolted double cover butt joint to connect boiler plates of thickness 16 mm for maximum efficiency. Use M 20 bolts of grade 4.6. Boiler plates are of Fe 410 grade. Draw the connection details.

**Solution:**  $d = 20 \text{ mm} \therefore d_o = 22 \text{ mm}$ .  $f_{ub} = 400 \text{ N/mm}^2$ ,  $f_u = 410 \text{ N/mm}^2$ ,  $t = 16 \text{ mm}$ . Since it is double cover but joint, the bolts are in double shear, one section at shank and another at root of thread are resisting shear.

$\therefore$  Nominal strength of bolt in shear,

$$V_{nsb} = \frac{400}{\sqrt{3}} \left( 1 \times \frac{\pi}{4} \times 20^2 + 1 \times 0.78 \times \frac{\pi}{4} \times 20^2 \right) = 129143 \text{ N}$$

$\therefore$  Design strength

$$V_{dsb} = \frac{V_{nsb}}{1.25} = \frac{129143}{1.25} = 103314 \text{ N}$$

Assuming bearing strength is more than this, to get maximum efficiency, strength of plate per pitch width is equated to  $V_{dsb}$ .

To avoid failure of the cover plates, the total thickness of the cover plates should be more than the thickness of the main plate. Provide cover plates of 12 mm thickness.

∴ Design strength of plate per pitch width

$$= \frac{0.9 \times 410 (p - 22)}{1.25} \times 16$$

$$= 4723.2 (p - 22)$$

Equating it to strength of bolt, we get

$$4723.2 (p - 22) = 103314$$

∴  $p = 43.87 \text{ mm.}$

Minimum pitch to be provided =  $2.5 d$

$$= 2.5 \times 20 = 50 \text{ mm}$$

Provide  $p = 50 \text{ mm.}$

### Check for Bearing Strength of Bolt

Minimum edge distance  $e = 1.7 d_o = 1.7 \times 22 = 37.4 \text{ mm}$

Provide  $e = 40 \text{ mm.}$

Then,  $k_b$  is minimum of  $\frac{e}{3d_o}$ ,  $\frac{P}{3d_o} - 0.25$ ,  $\frac{f_{ub}}{f_u}$ , 1.0

∴  $k_b = 0.5076$

∴ Design strength of bolt in bearing

$$= \frac{2.5 \times 0.5076 \times 20 \times 16 \times 400}{1.25}$$

$$= 129939 \text{ N} > 103314 \text{ N}$$

Hence, the assumption that design strength of bolt = 103314 N is correct.

Figure 2.4 shows the connection details.

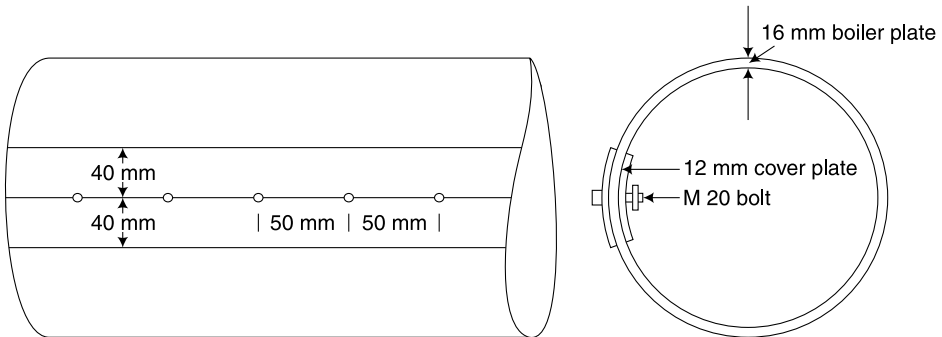

Fig. 2.4

## 2.6 ECCENTRIC CONNECTION WITH BEARING BOLTS

There are two cases of eccentric connections:

1. Moment in the plane of bolts
2. Moment at right angles to the plane of bolt.

### 2.6.1 When Moment is in the Plane of Bolts

If  $P$  is the eccentric load and 'e' is the eccentricity, moment to be resisted by bolts

$$M = Pe$$

If  $V_{db}$  is shear strength and  $V_{dpb}$  is strength in bearing, the strength of a bolt  $V$  is the lesser of the two.

The number of bolts per row required is given by  $n = \sqrt{\frac{6M}{2Vp}}$  where  $p$  is the pitch.

If  $r_i$  is the radial distance of the bolts, and  $r$  the radial distance of extreme bolt, then force in the extreme bolt in radial direction is

$$F_2 = \frac{Per}{\sum r_i^2}$$

Direct shear in vertical direction

$$F_1 = \frac{P}{n}, \text{ where } n \text{ is the total number of bolts.}$$

∴ Resultant force on extreme bolt

$$F = \sqrt{F_1^2 + F_2^2 + 2F_1F_2 \cos \theta}$$

where  $\theta$  is the angle between  $F_1$  and  $F_2$ .

For safe design  $F \leq V$

**Example 2.3** A bracket is to be bolted to the flange of the column, which is of ISHB 300 @ 577 N/m. If the bracket has to carry a design load of 800 kN at an eccentricity of 250 mm, design the connection using 8 mm cover plates and M 20 bolts of grade 4.6.

**Solution:** Factored load on each plate of bracket  $\frac{800}{2} = 400$  kN

Eccentricity = 250 mm.

∴ On each plate  $M = 400 \times 250 = 100000$  kN-mm  
 $= 100,000 \times 1000$  N-mm

Flange thickness of ISHB 300 @ 577 N/m is 10.6 mm and thickness of cover plate is 12 mm. Hence, the thickness of thinner member is 10.6 mm.

$d = 20$  mm  $d_o = 22$  mm  $f_{ub} = 400$  N/mm<sup>2</sup>

For rolled section  $f_u = 410$  N/mm<sup>2</sup>.



Bolts are in single shear.

∴ Design strength of bolt in single shear,

$$V_{db} = \frac{1}{1.25} \frac{400}{\sqrt{3}} \left( 0 + 0.78 \times \frac{\pi}{4} \times 20^2 \right)$$

$$= 45272 \text{ N}$$

Strength of the bolt in bearing:

$$k_b \text{ is the least of } \frac{e}{3d_o}, \frac{p}{3d_o} - 0.25, \frac{f_{ub}}{f_u}, 1.0$$

Adopting two rows of bolts each at 70 mm from the centre line of the column and pitch 50 mm ( $\geq 2.5d$ ),

$$k_b = 0.5076$$

$$\therefore V_{dpb} = \frac{1}{1.25} \times 2.5 \times 0.5076 \times 20 \times 8 \times 400$$

$$= 64973 \text{ N} > V_{db}$$

$$V = V_{db} = 45272 \text{ N}$$

∴ Number of bolts required per row

$$n = \sqrt{\frac{6M}{2Vp}}$$

$$= \sqrt{\frac{6 \times 100,000 \times 1000}{2 \times 45272 \times 50}} = 11.51$$

Provide 12 bolts in each row as shown in Fig. 2.5.

Distance of extreme bolt from the centre of gravity of bolt,

$$r = \sqrt{70^2 + 275^2} = 283.77 \text{ mm.}$$

$$\sum r_i^2 = 4 \left[ \sum_{i=1}^6 (x_i^2 + y_i^2) \right]$$

$$= 4 [6 \times 70^2 + 25^2 + 75^2 + 125^2 + 175^2 + 225^2 + 275^2]$$

$$= 832600 \text{ mm}^2$$

$$\therefore F_2 = \frac{Per}{\sum r_i^2} = \frac{400 \times 10^3 \times 250 \times 283.77}{832600} = 34082 \text{ N}$$

$$\text{Direct shear } F_1 = \frac{P}{2n} = \frac{400 \times 1000}{2 \times 12} = 16667 \text{ N}$$

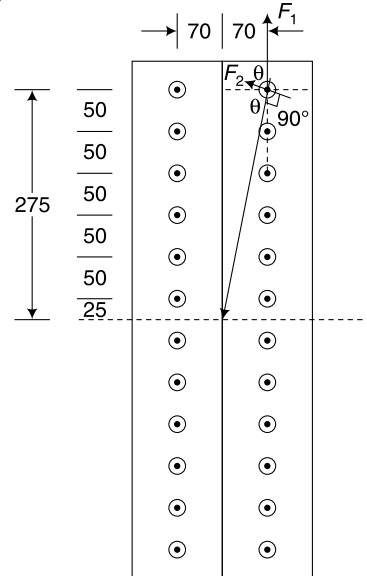

Fig. 2.5

$$\tan \theta = \frac{275}{70} \therefore \theta = 75.719^\circ \quad \text{Hence, } \cos \theta = 0.24668$$

$\therefore$  Resultant force on extreme bolt

$$\begin{aligned} &= \sqrt{F_1^2 + F_2^2 + 2F_1F_2 \cos \theta} \\ &= \sqrt{16667^2 + 34082^2 + 2 \times 16667 \times 34082 \times 0.24668} \\ &= 41467 \text{ N} < V \end{aligned}$$

$\therefore$  Design is safe.

Hence, provide 24 M 20 bolts as shown in Fig. 2.5.

### 2.6.2 When the Moment is at Right Angles to the Plane of Bolts

In this case bolts are subjected to shear and tension. If  $P$  is the eccentric load,  $n$  number of bolts in the connection, direct shear

$$V_{sb} = \frac{P}{n}$$

If  $e$  is the eccentricity of load, moment is

$$M = P \times e$$

Since on tension side only bolts resist the force while on compression side entire connecting angle in contact with column resists the force, the centre of gravity is assumed at  $\frac{1}{7}$  th the depth of the connection. Hence, moment resisted by bolts in tension,

$$M' = \frac{1}{\left[ 1 + \frac{2h}{21} \frac{\sum y_i}{\sum y_i^2} \right]}$$

where  $y_i$  is distance of  $i$ th bolt from CG and  $h$  is depth of connecting angle from topmost bolt. Then tensile force in the extreme bolt due to bending moment

$$T_b = \frac{M'y}{\sum y_i^2}$$

Design criteria to be satisfied is

$$\left( \frac{V_{sb}}{V_{db}} \right)^2 + \left( \frac{T_b}{T_{db}} \right)^2 \leq 1.0$$

where  $V_{db}$  = shear strength of bolt

$T_{db}$  = tensile strength of bolt.

#### Steps to be Followed in the Design

1. Select nominal diameter  $d$  of the bolt.
2. Adopt pitch = 2.5  $d$  to 3.0  $d$ .

3. Number of bolts in each row

$$= \sqrt{\frac{6M}{(2V)p}}$$

4. Find  $V_{sb}$ ,  $T_b$ ,  $T_{dh}$  and check for satisfying interaction formula.

**Example 2.4** Design a suitable bolted bracket connection for connecting a ISST-200 section to the flange of a ISHB 300 @ 577 N/m to carry a vertical factored load of 400 kN at an eccentricity of 150 mm. Use M20 bolts of grade 4.6 [Ref. Fig. 2.6]

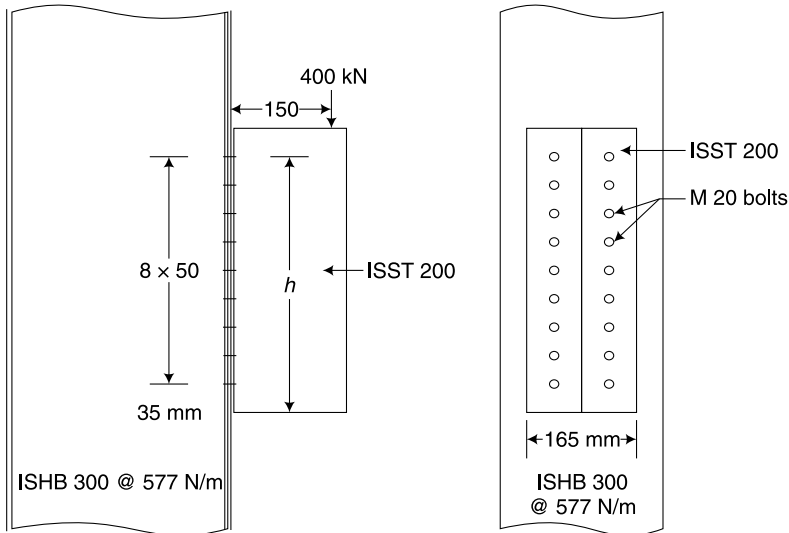

Fig. 2.6

**Solution:** For M 20 bolts of grade 4.6,  $d = 20$  mm,  $d_o = 22$  mm,  $f_{ub} = 400$  N/mm<sup>2</sup>,  $f_{yb} = 240$  N/m

For rolled steel section,  $f_u = 410$  N/mm<sup>2</sup>.

Thickness of flange of ISST 200 is 12.5 mm

Thickness of flange of ISHB 300 @ 577 N/m = 10.6 mm.

∴ Thickness of thinner member = 10.6 mm.

Design strength of M20 bolts in single shear

$$\begin{aligned} &= \frac{1}{1.25} \frac{400}{\sqrt{3}} \left[ 0 + 0.78 \times \frac{\pi}{4} \times 20^2 \right] \\ &= 45272 \text{ N} \end{aligned}$$

$$\text{Minimum edge distance} = 1.5 d_o = 1.5 \times 22 = 33 \text{ mm}$$

$$\text{Minimum pitch} = 2.5 d = 2.5 \times 20 = 50 \text{ mm.}$$

Let  $e = 35$  mm and  $p = 50$  mm.

$$k_b \text{ is the smaller of } \frac{35}{3 \times 22}, \frac{50}{3 \times 22} - 0.5, \frac{400}{410}, 1.0$$

i.e.,  $k_b = 0.5076$

Design strength of bolts in bearing against 10.6 mm thick flange of I-section

$$\begin{aligned} &= \frac{1}{1.25} \times 2.5 \times 0.5076 \times 20 \times 10.6 \times 400 \\ &= 86088 \text{ N} > V_{db} \end{aligned}$$

$\therefore$  Design strength of bolt in shear  $V = V_{db} = 45272$  N

Design tension capacity of bolt

$$\begin{aligned} T_{db} &= \frac{0.90 f_{ub} A_n}{\gamma_m} < \frac{f_{yb} A_{sb}}{\gamma_{mo}} \\ &= 0.90 \times 400 \times 0.78 \times \frac{\pi}{4} \times 20^2 < \frac{240 \times \frac{\pi}{4} \times 20^2}{1.1} \\ &= 88216 < 68544. \end{aligned}$$

$\therefore T_{db} = 68544$  N

Using two rows of bolts, number of bolts required in each row,

$$n = \sqrt{\frac{6M}{(2V)p}}$$

Now,

$$\begin{aligned} M &= 400 \times 150 \text{ kN-mm} \\ &= 400 \times 150 \times 10^3 \text{ N-mm.} \end{aligned}$$

$\therefore n = \sqrt{\frac{6 \times 400 \times 150 \times 10^3}{2 \times 45272 \times 50}} = 8.91$

Provide 9 bolts in each row as shown in Fig. 2.6.

$$h = 35 + 50 \times (9 - 1) = 435 \text{ mm.}$$

$$\frac{h}{7} = \frac{435}{7} = 62.14 \text{ mm}$$

i.e., neutral axis lies between bolt nos. 1 and 2 counted from bottom.

$\therefore y_2 = 35 + 50 - 62.14 = 22.86$  mm

Bolt No.	2	3	4	5	6	7	8	9
$y$	22.86	72.86	122.86	172.86	222.86	272.86	322.86	372.86

$\therefore \sum y_i = 1582.86 \times 2$  mm

$$\sum y_i^2 = 418188 \times 2 \text{ mm}^2$$

### Design Shear Strength of Bolts

$$V_{dsf} = \frac{1}{1.25} \mu_f n_e k_n F_o$$

$$\mu_f = 0.48, n_e = 1, k_n = 1 \text{ for fasteners in clearance}$$

$$\begin{aligned} F_o &= A_{ub} f_o = 0.78 \times \frac{\pi}{4} \times 24^2 \times 0.7 \times 800 \\ &= 197604 \text{ N} \end{aligned}$$

$$\begin{aligned} \therefore V_{dsF} &= 1/1.25 \times 0.48 \times 1 \times 1 \times 197604 \\ &= 75880 \text{ N} \end{aligned}$$

Since there are two rows of bolts in the connection, number of bolts required per row when  $p = 70$  mm and taking  $V = V_{dsf}$ , we get

$$n = \sqrt{\frac{6M}{(2V)p}} = \sqrt{\frac{6 \times 600 \times 1000 \times 250}{2 \times 75880 \times 70}} = 9.2$$

Provide 10 bolts in each row with edge distance 40 mm as shown in Fig. 2.7.

Tensile capacity of bolts

$$\begin{aligned} &= \frac{1}{1.25} \times 0.9 f_{ub} A_{ub} \\ &= \frac{1}{1.25} \times 0.9 \times 800 \times 0.78 \times \frac{\pi}{4} \times 24^2 \\ &= 203250 \text{ N} \end{aligned}$$

When there is no load, the bracket is held on to the column by compression developed due to the bolt tension. This phenomenon continues even after the load is applied. Hence, the interface of the area  $150 \times 710$  mm may be considered a plane in a monolithic beam. The stress diagram is shown in Fig. 2.7.

$$\begin{aligned} \text{Max. bending stress} &= \frac{6M}{bd^2} = \frac{6 \times 600 \times 10^3 \times 250}{150 \times 710^2} \\ &= 11.9 \text{ N/mm}^2 \end{aligned}$$

$$\begin{aligned} \text{Bending stress at } 40 + \frac{70}{2} = 75 \text{ mm from top flange} \\ &= 11.9 \times \frac{355 - 75}{355} = 9.39 \text{ N/mm}^2. \end{aligned}$$

$$\therefore \text{Average stress} = \frac{11.9 + 9.39}{2} = 10.64 \text{ N/mm}^2$$

This average bending stress could be considered tension in the bolt.

$$\therefore \text{Tension in extreme two bolts, } 2T_e = 10.64 \times 150 \times 75$$

$$2T_e = 119744 \text{ N.}$$

$$\therefore T_e = 59872 \text{ N}$$

### Prying Forces

Plate width = 150 mm. Plate thickness = 12 mm

$$l_v = \frac{150}{2} - 6 - 8 - 40 = 21 \text{ mm.}$$

where 8 mm is assumed thickness of weld

For the connecting plate,  $f_u = 410 \text{ N/mm}^2$ ,  $f_y = 250 \text{ N/mm}^2$

$$\therefore l_c = 1.1 \times 12 \times \frac{\sqrt{1 \times 0.7 \times 410}}{250} = 14.14 \text{ mm} < \text{edge distance}$$

$$\therefore l_c = 14.14 \text{ mm.}$$

$\beta = 1.0$  for pretensioned bolts.

$$b_e = 150 \text{ mm, } f_o = 0.7, f_{ub} = 0.7 \times 800 = 560 \text{ N/mm}^2$$

$$t = 12 \text{ mm.}$$

$\therefore$  Prying force  $Q$  is given by

$$\begin{aligned} Q &= \frac{l_v}{2l_c} \left[ T_e - \frac{\beta n f_o b_e t^4}{27 l_c l_v^2} \right] \\ &= \frac{21}{2 \times 14.14} \left[ 59872 - \frac{1.0 \times 1.5 \times 560 \times 150 \times 12^4}{27 \times 14.14 \times 21^2} \right] \\ &= 32936 \text{ N} \end{aligned}$$

$\therefore$  Total tensile force in the bolt

$$T_f = 59872 + 32936 = 92808 \text{ N}$$

$$\text{Tension capacity } T_{df} = \frac{1}{1.25} \times 0.9 f_{ub} A_n$$

$$= \frac{1}{1.25} \times 0.9 \times 800 \times 0.78 \times \frac{\pi}{4} \times 24^2$$

$$= 203249 \text{ N}$$

$$\text{Direct shear in the bolt} = \frac{600 \times 1000}{2 \times 10} = 30000 \text{ N}$$

$$\therefore \left( \frac{V_{sb}}{V_{dsf}} \right)^2 + \left( \frac{T_f}{T_{dsf}} \right)^2 = \left( \frac{30000}{75880} \right)^2 + \left( \frac{92808}{203249} \right)^2$$

$$= 0.365 < 1.0$$

Hence, OK.