

Test Report:

BQ76942 IEC ESD 61000-4-2 Test Report



Willy Massoth and Matt Sunna

ABSTRACT

The IEC 61000-4-X set of standards are used to test system-level transient immunity. Many system designs used in an industrial environment specify one or more of the tests listed within the IEC 61000-4-X specification to comply with reliability standards for end customers. This document covers the TI BQ76942 battery monitor device system ESD Immunity (IEC 6100-4-2) using a 2-layer test board, This document provides the test setup and results for each of these tests

Table of Contents

1 IEC 61000-4-2 System ESD Immunity.....	2
2 BQ76942 Test Board.....	3
3 List of Equipment.....	6
4 IEC 61000-4-2 System ESD Immunity.....	7
5 References.....	10

List of Figures

Figure 2-1. BQ76942 IEC ESD Test Board Schematic Page 1.....	3
Figure 2-2. BQ76942 IEC ESD Test Board Schematic Page 2.....	4
Figure 2-3. BQ76942 IEC ESD Test Board (Standard) Top View.....	5
Figure 4-1. ESD Test Bench Setup.....	8

List of Tables

Table 3-1. List of Equipment.....	6
Table 4-1. ESD Stress Levels.....	7
Table 4-2. ESD Testing Contact Discharge Results.....	8
Table 4-3. ESD Testing Air Discharge Results.....	8

Trademarks

All trademarks are the property of their respective owners.

1 IEC 61000-4-2 System ESD Immunity

1.1 IEC61000-4-2 Overview

The IEC 61000-4-2 standard covers system level ESD immunity. Electrostatic Discharge can be very harmful to a system and even a small amount of voltage can damage components. Most systems require some sort of IEC ESD protection, as any user accessible areas can be subjected to ESD strikes. Although this test is considered a 'system level' test, TI decided to measure the ESD Immunity (IEC 6100-4-2) of the TI BQ76942 battery monitor device using a 2-layer test board to provide customers with an idea of how high their system can pass with the TI BQ76942 battery monitor in their system.

1.2 BQ76942 Overview

The Texas Instruments BQ76942 is a highly integrated, high accuracy battery monitor and protector for 3-series to 10-series Li-Ion, Li-Polymer, and LiFePO4 battery packs. The device includes a high accuracy monitoring system, a highly configurable protection subsystem, and support for autonomous or host controlled cell balancing. Integration includes high-side charge-pump NFET drivers, dual programmable LDOs for external system use, and a host communication peripheral supporting 400-kHz I2C, SPI, and HDQ one-wire standards. The BQ76942 is available in a 48-pin TQFP package.

2 BQ76942 Test Board

These tests are done using a 2-layer BQ76942 test board configured for a 7-cell application. The IC on the board is programmed to factory default settings with OTP programming for the following parameters:

- **VCell Mode** = 0x023F to configure the device for a 7-cell battery
- **REG0 Config** = 0x01 and **REG12 Config** = 0x0D to enable and set the REG1 output to 3.3V
- **Mfg Status Init** = 0x0050 to enable the CHG and DSG FETs at power up.

Figure 2-1 and Figure 2-2 shows the schematic of the BQ76942 test board.

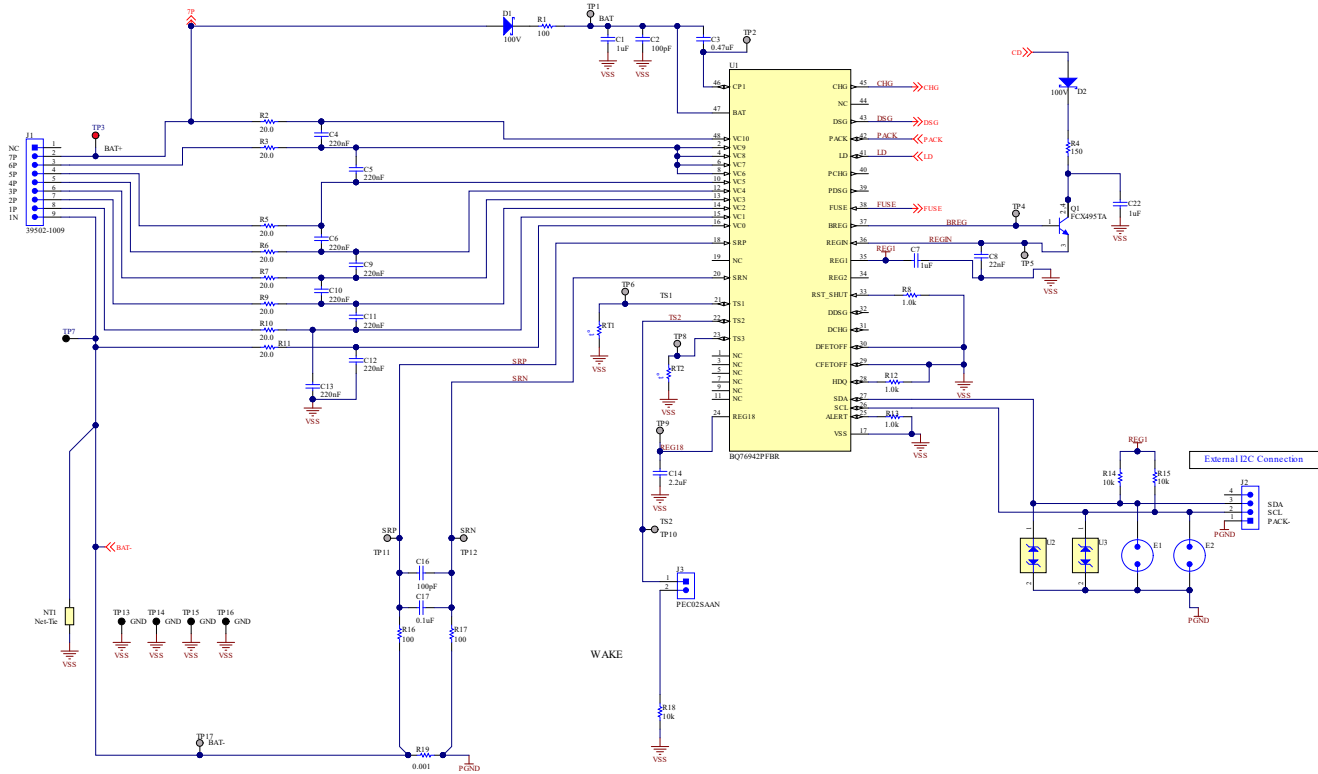

Figure 2-1. BQ76942 IEC ESD Test Board Schematic Page 1

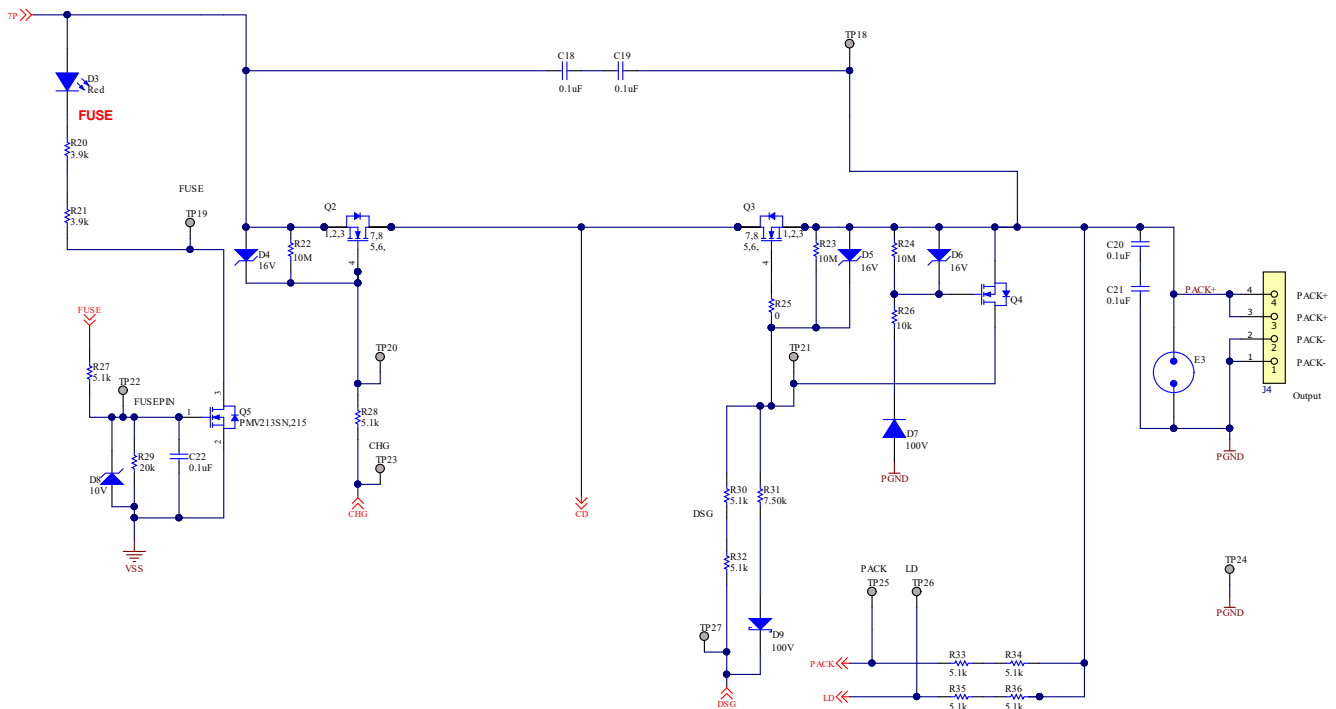

Figure 2-2. BQ76942 IEC ESD Test Board Schematic Page 2

Figure 2-3 is the top view of the BQ76942 test board.

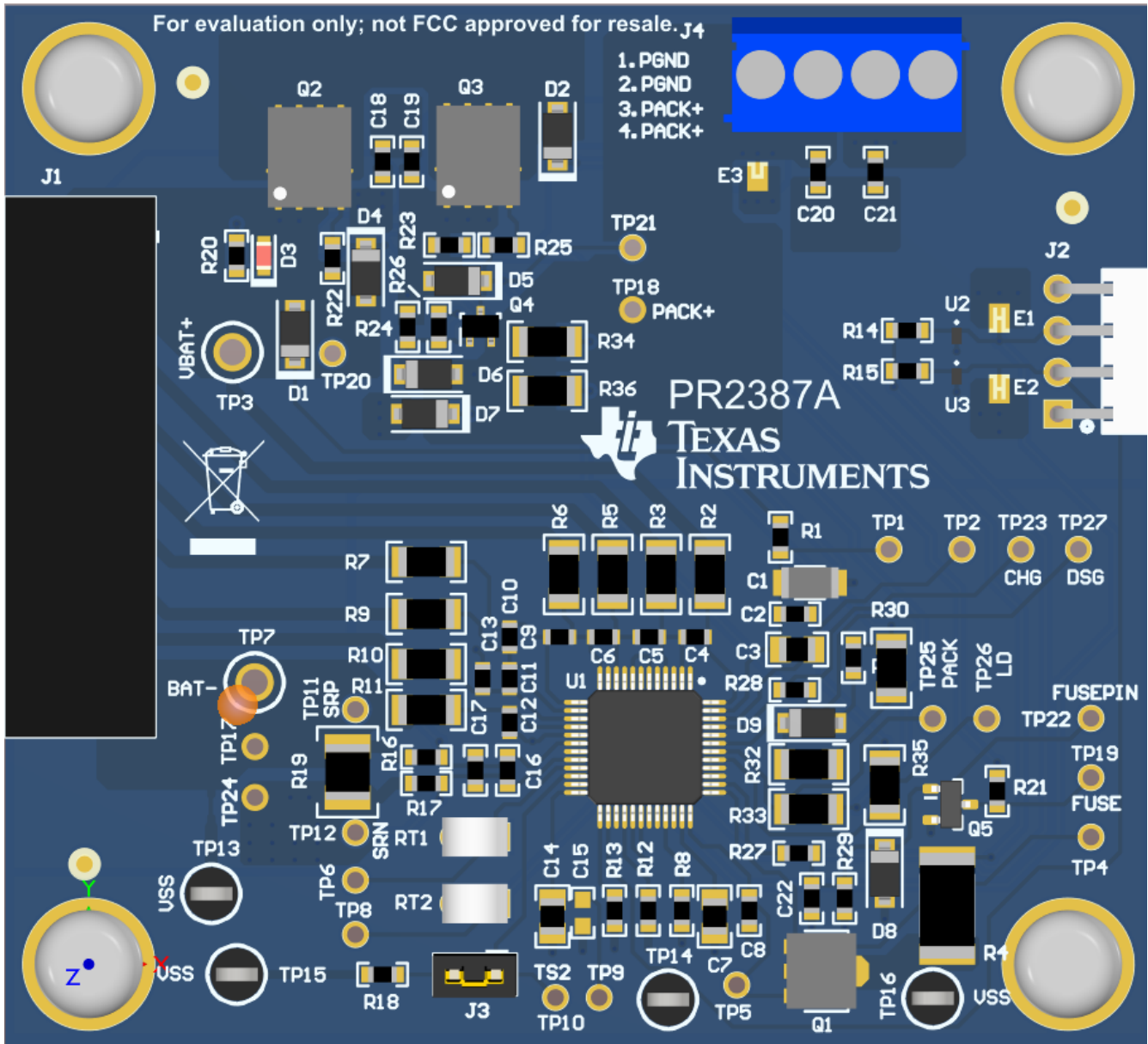

Figure 2-3. BQ76942 IEC ESD Test Board (Standard) Top View

3 List of Equipment

Table 3-1 shows the list of required equipment.

Table 3-1. List of Equipment

Qty	Equipment	Description
1	ESS-2000	ESD Generator
2	7-Cell battery	7-Cell battery charged to ~28V
3	Fluke 189	Multimeter
4	BQ76942 Test board	2-Layer typical application test board

4 IEC 61000-4-2 System ESD Immunity

4.1 IEC61000-4-2 (ESD) Stress Levels

See [Table 4-1](#) for levels specified by the IEC 61000-4-2 standard..

Table 4-1. ESD Stress Levels

Level	Contact Discharge	Air Discharge
	Test Voltage (\pm kV)	Test Voltage (\pm kV)
1	2	2
2	4	4
3	6	8
4	8	15
X	Custom	Custom

4.2 Test Conditions

The following test conditions exist for IEC61000-4-2 system ESD immunity:

- 7-Cell battery, always connected
- LED and 3.9 k resistor connect between PACK- and PACK+ to indicate state of FETs

4.3 Test Signals

According to the IEC 61000-4-2:

- Contact discharge and air discharge
- Polarity: positive and negative
- Discharge unit: 150 pF, 330 Ω
- Applied to: BQ76942 board contact under test

4.4 Test Setup

The TI ESD test bench setup complies with the IEC standard and is shown in Figure 4. The BQ76942 test board is placed on a horizontal coupling plane (HCP) with insulation in between. Any power connections are made on the non-conductive table and two 470-k Ω resistors are used to connect the HCP to the ground reference plane (GRP).

The ESD contact discharge pulses have been applied to the critical device pin connections that are commonly available on the outside connector of a battery pack (PACK+, PACK-, SDA, SCL). The board is always connected to the battery during the test.

Testing is performed by charging the 150 pF discharge capacitor and discharging it through a 330- Ω resistor into the strike tip. Contact discharge is performed by touching the discharge tip directly to the pin under test then triggering the strike. Conversely, air discharge is performed by triggering the gun then moving the discharge tip towards the pin under test until arcing occurs.

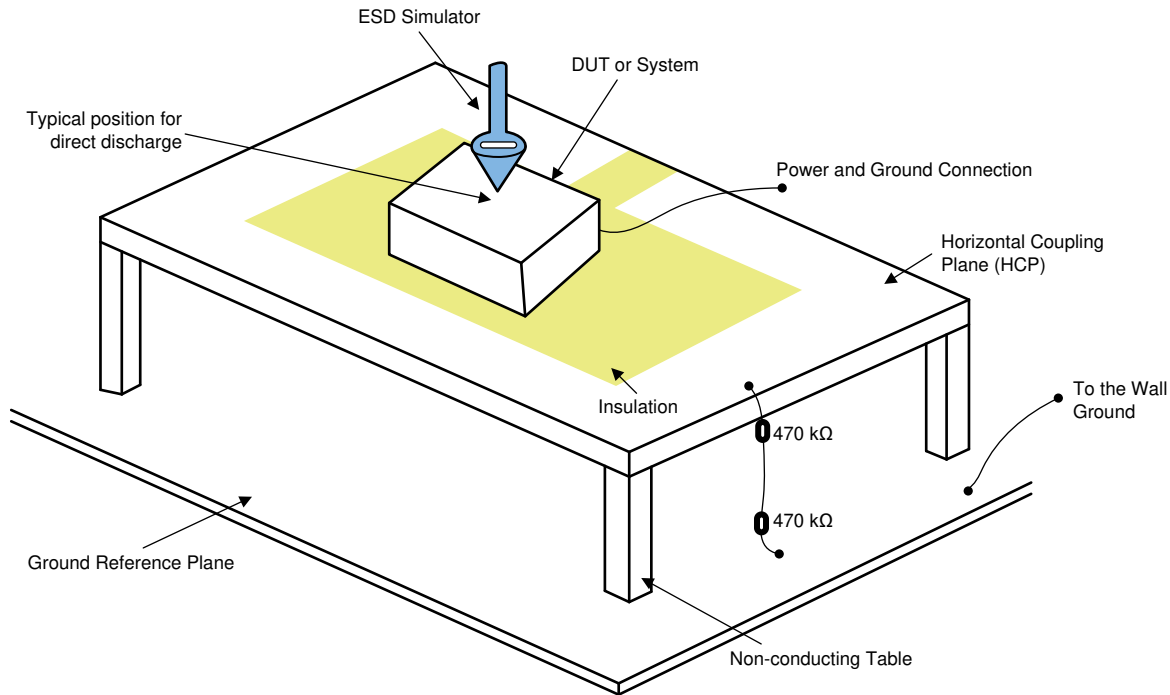

Figure 4-1. ESD Test Bench Setup

4.5 Classification of the Test

- (A) Normal performance within the limits specified by the manufacturer, requester or purchaser.
- (B) Temporary loss of function or temporary degradation of performance not requiring an operator.
- (C) Temporary loss of function or degradation of performance, the correction of which requires operator intervention.
- (D) Loss of function or degradation of performance which is not recoverable, owing to damage of the hardware or software, or loss of data.

4.6 Test Results

Test results are listed in [Table 4-2](#) and [Table 4-3](#):

Table 4-2. ESD Testing Contact Discharge Results

ESD Test Signal Amplitude, Test Result At Polarity (\pm)							
Applied to	2 kV	4 kV	6 kV	8 kV	10kV	15kV	20kV
PACK+	A/A	A/A	A/A	A/A	A/A	A/A	A/A
PACK-	A/A	A/A	A/A	A/A	A/A	A/A	A/A
SCL	A/A	A/A	A/A	A/A	A/A	A/A	A/A
SDA	A/A	A/A	A/A	A/A	A/A	A/A	A/A

Table 4-3. ESD Testing Air Discharge Results

ESD Test Signal Amplitude, Test Result At Polarity (\pm)						
Applied to	2 kV	4 kV	8 kV	15 kV	20kV	25kV
PACK+	A/A	A/A	A/A	A/A	A/A	A/A
PACK-	A/A	A/A	A/A	A/A	A/A	A/A
SCL	A/A	A/A	A/A	A/A	A/A	A/A
SDA	A/A	A/A	A/A	A/A	A/A	A/A

4.7 Conclusion

The tested BQ76942 2-layer IEC ESD test board passed all of the ESD immunity tests against ESD applied to critical pins in contact discharge mode. According to [Section 4.1](#), it passed specified levels of the IEC standard. From [Section 4.6](#), ESD applied to these pins had no influence on the performance of the board up to 20 kV (contact discharge) and 25 kV (air discharge).

5 References

- Texas Instruments, [BQ76942 3S-10S Battery Monitor and Protector data sheet](#)
- Texas Instruments, [BQ76952 3S-16S Battery Monitor and Protector data sheet](#)

IMPORTANT NOTICE AND DISCLAIMER

TI PROVIDES TECHNICAL AND RELIABILITY DATA (INCLUDING DATASHEETS), DESIGN RESOURCES (INCLUDING REFERENCE DESIGNS), APPLICATION OR OTHER DESIGN ADVICE, WEB TOOLS, SAFETY INFORMATION, AND OTHER RESOURCES "AS IS" AND WITH ALL FAULTS, AND DISCLAIMS ALL WARRANTIES, EXPRESS AND IMPLIED, INCLUDING WITHOUT LIMITATION ANY IMPLIED WARRANTIES OF MERCHANTABILITY, FITNESS FOR A PARTICULAR PURPOSE OR NON-INFRINGEMENT OF THIRD PARTY INTELLECTUAL PROPERTY RIGHTS.

These resources are intended for skilled developers designing with TI products. You are solely responsible for (1) selecting the appropriate TI products for your application, (2) designing, validating and testing your application, and (3) ensuring your application meets applicable standards, and any other safety, security, or other requirements. These resources are subject to change without notice. TI grants you permission to use these resources only for development of an application that uses the TI products described in the resource. Other reproduction and display of these resources is prohibited. No license is granted to any other TI intellectual property right or to any third party intellectual property right. TI disclaims responsibility for, and you will fully indemnify TI and its representatives against, any claims, damages, costs, losses, and liabilities arising out of your use of these resources.

TI's products are provided subject to TI's Terms of Sale (www.ti.com/legal/termsofsale.html) or other applicable terms available either on ti.com or provided in conjunction with such TI products. TI's provision of these resources does not expand or otherwise alter TI's applicable warranties or warranty disclaimers for TI products.

Mailing Address: Texas Instruments, Post Office Box 655303, Dallas, Texas 75265
Copyright © 2020, Texas Instruments Incorporated