



Highly Reliable
Hysteresis
Devices for
Tension and
Torque Control

- Hysteresis Brakes
- Compressed-Air-Cooled Brakes
- Matched Brakes
- Hysteresis Clutches
- Large Bore Brakes
- Permanent Magnet Brakes & Clutches
- Convection Powder Brakes



BRAKES & CLUTCHES

PRINCIPLES OF HYSTERESIS

In an electrically operated Hysteresis Brake resistance to rotation is proportional to applied current from virtually zero to rated torque.

Advantages

- Long, Maintenance-Free Life
- Life Cycle Cost Advantages
- Operational Smoothness
- Superior Torque Repeatability
- Broad Speed Range
- Excellent Environmental Stability

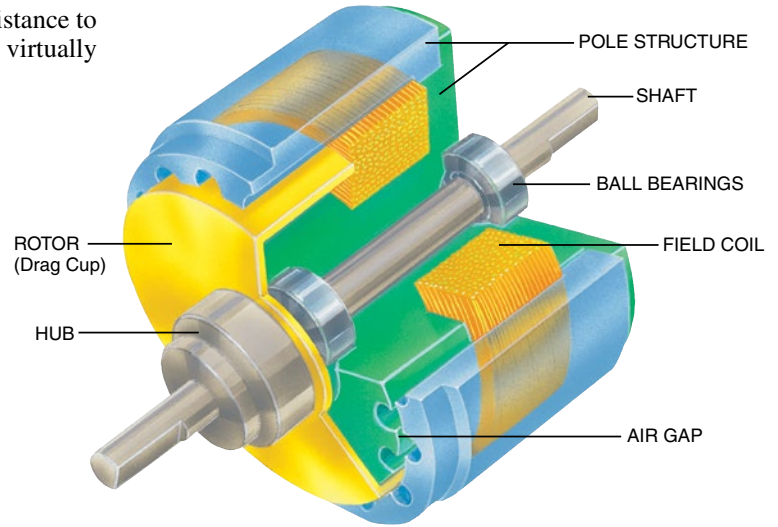

APPLICATIONS

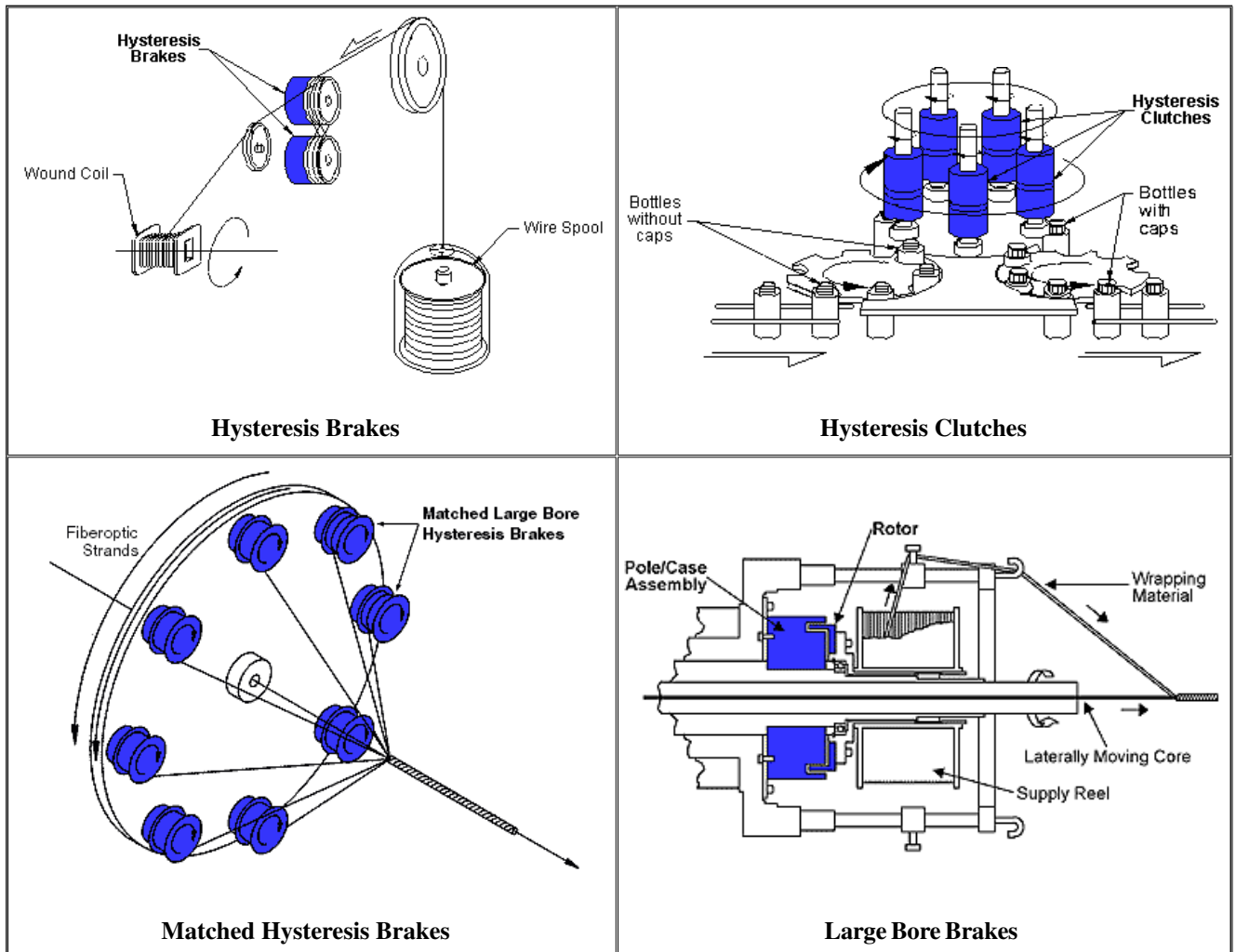

HYSSTERESIS BRAKES

STANDARD BRAKES

Pure Hysteresis Brakes produce torque strictly through a magnetic air gap without the use of magnetic particles or friction components. This method of braking provides far superior operating characteristics (smoother torque, longer life, superior repeatability, high degree of controllability, and less maintenance and down time) which make them the preferred choice for precise tension control during the processing of nearly any material, web or strand.



ENGLISH BRAKE RATINGS										
Model	Min. Torque at Rated Current oz-in	Rated Current mA	Resistance at 25 °C ±10% Ω	Voltage* VDC	Nominal Power W	Max. Speed rpm	Kinetic Power**		Drag Torque De-energized @1000 rpm oz-in	
							5 Minutes W	Continuous W		
HB-2.5-2	2.5	146	171	25.0	3.7	20,000	20	5	0.05	
HB-10-2	10	133	180	24.0	3.2	20,000	45	12	0.10	
HB-16-2	16	192	125	24.0	4.6	20,000	75	20	0.10	
HB-38-2	38	250	105	26.3	6.6	15,000	90	25	0.20	
HB-50-2	50	253	95	24.0	6.1	15,000	90	23	0.20	
HB-140-2	140	253	95	24.0	6.1	12,000	300	75	0.70	
HB-250-2	250	270	96	25.9	7.0	10,000	450	110	1.00	
HB-450-2	450	442	50	22.1	9.8	8,000	670	160	2.00	
HB-750-2	750	383	60	23.0	8.8	7,000	1,000	200	7.00	
HB-840-2	840	600	40	24.0	14.4	6,000	1,340	300	4.00	
HB-1750-2	1750	500	52	26.0	13.0	6,000	1,200	350	13.00	
HB-3500-2	3500	1000	26	26.0	26.0	6,000	2,400	600	19.20	

METRIC BRAKE RATINGS										
Model	Min. Torque at Rated Current N-m	Rated Current mA	Resistance at 25 °C ±10% Ω	Voltage* VDC	Nominal Power W	Max. Speed rpm	Kinetic Power**		Drag Torque De-energized @1000 rpm N-m	
							5 Minutes W	Continuous W		
HB-3M-2	0.02	145	171	25.0	3.59	20,000	20	5	3.53 × 10 ⁻⁴	
HB-10M-2	0.07	133	180	24.0	3.18	20,000	35	8	7.06 × 10 ⁻⁴	
HB-20M-2	0.14	217	120	26.0	5.60	20,000	50	12	7.77 × 10 ⁻⁴	
HB-50M-2	0.35	253	95	24.0	6.10	15,000	90	23	1.55 × 10 ⁻³	
HB-140M-2	1.00	253	95	24.0	6.10	12,000	300	75	5.42 × 10 ⁻³	
HB-250M-2	1.75	270	96	25.9	7.00	10,000	450	110	7.77 × 10 ⁻³	
HB-450M-2	3.20	442	50	22.1	9.80	8,000	670	160	1.51 × 10 ⁻²	
HB-750M-2	5.00	383	60	23.0	8.80	7,000	1,000	200	5.00 × 10 ⁻²	
HB-1750M-2	† 13.00	600	52	31.2	13.00	6,000	1,200	350	9.18 × 10 ⁻²	
HB-3500M-2	†† 26.00	1200	26	31.2	26.00	6,000	2,400	600	1.36 × 10 ⁻¹	

* 12 VDC, 90 VDC and non-standard coil voltages are available on most models.

** Kinetic power ratings are maximum values based on limiting coil and/or bearing temperature to approximately 100 °C, and should not be exceeded. Actual values in service may vary ±50% depending on mounting, ventilation, ambient temperature, etc.

† 13 N-m is attainable at approx. 600 mA. This value may decrease to 12.36 N-m if the brake is powered by any power supply or controller limited to 500 mA.

†† 26 N-m is attainable at approx. 1200 mA. This value may decrease to 24.72 N-m if the brake is powered by any power supply or controller limited to 1000 mA.

COMPRESSED-AIR-COOLED BRAKES

When torque control/torque measurement must be performed at the highest possible power, Magtrol AHB Series Hysteresis Brakes are ideal. Passages running through the brakes enables compressed air cooling, providing excellent heat dissipation. Allowable input air pressure of up to 95 PSI eliminates the need for a regulator and convenient base mounting enables easy configuration.



RATINGS (Available in Metric Only)									
Model	Min. Torque at Rated Current N-m	Rated Current mA	Voltage VDC	Nominal Power W	Max. Speed rpm	Kinetic Power*			
						With Air		Without Air	
						5 Minutes W	Continuous W	5 Minutes W	Continuous W
AHB-1	1.00	400	24.0	9.6	25,000	1200	1200	250	55
AHB-1.5	1.50	400	25.6	10.24	25,000	1300	1300	450	70
AHB-3	3.00	750	24.8	18.6	20,000	1800	1800	800	160
AHB-5	5.00	380	22.8	8.7	15,000	2500	1000	1300	120
AHB-6	6.00	1500	24.8	37.1	20,000	3000	3000	1400	225
AHB-12	12.00	1200	24.0	28.8	12,000	2800	1800	2200	250
AHB-24	24.00	2400	24.0	57.6	12,000	5300	3000	4000	450

* Kinetic power ratings are maximum values based on limiting coil and/or bearing temperature to approximately 100 °C, and should not be exceeded.

MATCHED BRAKES



Magtrol has developed a system to assure that every brake of a given model designation will be matched, at a predetermined torque and current point, to other brakes of the same model designation regardless of material and manufacturing tolerances. Each brake will be matched at the selected match point to within a tolerance of $\pm 1\%$.

ENGLISH BRAKE RATINGS									
Model	Min. Torque at Rated Current	Rated Current	Resistance at 25 °C $\pm 10\%$	Voltage*	Nominal Power	Max. Speed	Kinetic Power**		Drag Torque De-energized @1000 rpm
							5 Minutes	Continuous	
	oz-in	mA	Ω	VDC	W	rpm	W	W	oz-in
MHB-2.5-2	2.5	98	262	25.0	3.7	20,000	20	7	0.05
MHB-10.5-2	11	201	113	24.0	3.2	20,000	60	15	0.10
MHB-38-2	38	250	105	26.3	6.6	15,000	90	25	0.20
MHB-50-2	50	253	95	24.0	6.1	15,000	90	23	0.20
MHB-140-2	140	253	95	24.0	6.1	12,000	300	75	0.70
MHB-250-2	250	270	96	25.9	7.0	10,000	450	110	1.00
MHB-450-2	450	442	50	22.1	9.8	8,000	670	160	2.00
MHB-750-2	750	383	60	23.0	8.8	7,000	1,000	200	7.00
MHB-1750-2	1750	500	52	26.0	13.0	6,000	1,200	350	13.00

* 12 VDC, 90 VDC and non-standard coil voltages are available on most models.

** Kinetic power ratings are maximum values based on limiting coil and/or bearing temperature to approximately 100 °C, and should not be exceeded. Actual values in service may vary $\pm 50\%$ depending on mounting, ventilation, ambient temperature, etc.

METRIC BRAKE RATINGS									
All standard metric brakes are also available in matched brake configurations, with the exception of the HB-3500M Series. Technical data for these brakes is identical to that of its standard counterpart. For example, the MHB-140M-2 has the same ratings as the HB-140M-2.									

HYSTERESIS CLUTCHES

Like Magtrol's Hysteresis Brake, the Hysteresis Clutch develops torque strictly through a magnetic air gap, ensuring an absolutely smooth transmission of torque from the drive unit to the driven element. Designed to be powered without the use of brushes or slip rings, and being a pure hysteresis device, there is never any fear of contamination due to wear particles or leaky seals.



RATINGS (Available in Metric Only)										
Model	Min. Torque at Rated Current	Rated Current	Resistance at 25 °C $\pm 10\%$	Voltage*	Nominal Power	Max. Speed	Kinetic Power**		Inertia	
							5 Minutes	Continuous	Input Shaft	Output Shaft
	N-m	mA	Ω	VDC	W	rpm	W	W	kg-cm ²	kg-cm ²
HCF-8M	0.0565	150	180.0	27.0	4.05	3600	60	15	0.299	0.038
HCF-16M	0.113	270	100.0	27.0	7.29	3600	75	20	0.543	0.041
HCF-32M	0.226	332	72.5	24.0	7.99	3600	90	25	0.984	0.089
HCF-120M	0.850	200	120.0	24.0	4.80	3600	300	75	9.490	0.910
HCF-250M	1.800	415	60.0	24.9	10.30	3600	450	110	25.560	2.760

* 12 VDC, 90 VDC and non-standard coil voltages are available on all models.

** Kinetic power ratings are maximum values based on limiting coil and/or bearing temperature to approximately 100 °C, and should not be exceeded. Actual values in service may vary $\pm 50\%$ depending on mounting, ventilation, ambient temperature, etc.

Complete technical specifications for most of the products described in this brochure, including detailed dimension drawings, are available on our web site:
www.magtrol.com

3-D model and/or installation drawings are available upon request.

LARGE BORE BRAKES

For many years Magtrol has designed Hysteresis Brakes with large bores, and without a shaft or bearings. These brakes are used for superior tension control for helical wrapping, braiding and other feed through applications in machines used for manufacturing cable, wire, fiber optic cable, rope and tape, among others. Magtrol Large Bore Brakes provide smooth, repeatable torque, largely independent of speed.



RATINGS (Available in Metric Only)								
Model	Min. Torque at Rated Current	Rated Current	Resistance at 25 °C ±10%	Voltage*	Nominal Power	Max. Speed	Kinetic Power**	
	<i>N-m</i>	<i>mA</i>	Ω	<i>VDC</i>	<i>W</i>	<i>rpm</i>	5 Minutes	Continuous
LB-250M-2	1.50	270	95	25.6	6.99	3000	450	110
LB-450M-2	3.00	442	50	22.1	9.80	2500	670	160
LB-750M-2	5.00	383	60	23.0	8.82	2000	1000	200
LB-1750M-2	12.00	500	52	26.0	13.00	1800	1200	350

* Higher speeds, up to 8000 rpm, are available on special basis.

** Kinetic power ratings are maximum values based on limiting coil and/or bearing temperature to approximately 100 °C, and should not be exceeded. Actual values in service may vary ±50% depending on mounting, ventilation, ambient temperature, etc.

PERMANENT MAGNET BRAKES & CLUTCHES

Magtrol Hysteresis Permanent Magnet Brakes and Clutches are ideal in applications where electrical power cannot be provided to a brake or clutch coil. While best suited to applications where fixed torque is to be applied, adjustable units can be made specifically tailored to the application.



RATINGS (Available in English Only)					
Brake Model	Clutch Model	Rated Torque*	Maximum Speed**	Kinetic Power	
		<i>oz-in</i>	<i>rpm</i>	5 Minutes	Continuous
HPM-2.5	HPMC-2.5	2.5	10,820	20	7
HPM-8	HPMC-8	8	10,140	60	15
HPM-16	HPMC-16	16	6,340	75	20
HPM-32	HPMC-32	32	3,800	90	25
HPM-120	HPMC-120	120	3,380	300	75
HPM-210	HPMC-210	210	2,900	450	110

* Permanent Magnet Brakes can be charged at factory to produce lower torque if desired.

** Maximum speed listed will produce 5-minute kinetic power rating at rated torque.

POWER SUPPLIES

MODEL 5200 POWER SUPPLY

Model 5200 is an unregulated 0–35 V DC Power Supply which offers control and regulation of the braking torque via a 10-turn potentiometer.



Model 5211 Power Supply

MODEL 5211 CURRENT REGULATED POWER SUPPLY

The Model 5211 provides the same control capabilities as the 5200, and also provides current regulation of the brake. With regulated current, the 5211 will eliminate torque drift caused by temperature changes within the brake coil.

MODEL 5251-2 CURRENT REGULATED POWER SUPPLY

Model 5251-2 is an open frame, current regulated power supply that provides smooth application of current from zero to maximum by either a 10-turn 5 k Ω potentiometer, or by an external 0–5 V DC control signal.

VM SERIES PROPORTIONAL AMPLIFIER/CONTROLLER

The VM Series Proportional Amplifier/Controller is used to supply and control current (up to 3 A) to Magtrol Hysteresis Brakes and Clutches and Convection Powder Brakes.



Model VM8 Proportional Amplifier/Controller

OPTIONS

Common Modifications

- Non-Standard Coil Voltages
- Special Shaft Configurations: keyways, flats, holes and hollow
- Dust Covers
- Speed Pickups
- Special Mounting Configurations
- Non-Standard Lead: material, lengths, location
- Higher Torque Devices
- High Speed Units

Higher Torque Capability

It is Magtrol's policy never to overstate the capabilities of our products. As a result, our brakes are conservatively rated. Higher torque values (15-25% above rated torque) are typically available from each brake, depending on the brake being ordered. In addition, special designs capable of producing even higher torques are available.

Brake Options

Base Mounting • Torque Current Curves • Pillow Blocks

Due to the continual development of our products, we reserve the right to modify specifications without forewarning.

For more information, contact your local sales agent:

HB-US www.10/19



MAGTROL INC

70 Gardenville Parkway
Buffalo, New York 14224 USA

Phone: +1 716 668 5555

Fax: +1 716 668 8705

E-mail: magtrol@magtrol.com

MAGTROL SA

Route de Montena 77
1728 Rossens/Fribourg, Switzerland

Phone: +41 (0)26 407 3000

Fax: +41 (0)26 407 3001

E-mail: magtrol@magtrol.ch

Subsidiaries in:

Germany • France

China • India

For worldwide network of sales agents, visit our web site:

www.magtrol.com