



GUIDE FOR

**BUCKLING AND ULTIMATE STRENGTH ASSESSMENT
FOR OFFSHORE STRUCTURES**

APRIL 2004 (Updated August 2018 – see next page)

**American Bureau of Shipping
Incorporated by Act of Legislature of
the State of New York 1862**

**© 2004-2018 American Bureau of Shipping. All rights reserved.
ABS Plaza
16855 Northchase Drive
Houston, TX 77060 USA**

Updates

August 2018 consolidation includes:

- January 2018 version plus Corrigenda/Editorials

January 2018 consolidation includes:

- January 2017 version plus Notice No. 3

January 2017 consolidation includes:

- February 2014 version plus Corrigenda/Editorials

February 2014 consolidation includes:

- March 2013 version plus Corrigenda/Editorials

March 2013 consolidation includes:

- February 2012 version plus Corrigenda/Editorials

February 2012 consolidation includes:

- November 2011 version plus Notice No. 2

November 2011 consolidation includes:

- July 2011 version plus Notice No. 1

July 2011 consolidation includes:

- July 2010 version plus Corrigenda/Editorials

July 2010 consolidation includes:

- October 2008 version plus Corrigenda/Editorials

October 2008 consolidation includes:

- June 2007 version plus Corrigenda/Editorials

June 2007 consolidation includes:

- June 2006 – Corrigenda/Editorials
- June 2007 – Corrigenda/Editorials and added list of updates

Foreword

This *Guide for the Buckling and Ultimate Strength Assessment of Offshore Structures* is referred to herein as “this Guide”. This Guide provides criteria that can be used in association with specific Rules and Guides issued by ABS for the classification of specific types of Offshore Structures. The specific Rules and Guides that this Guide supplements are the latest editions of the following.

- *Rules for Building and Classing Offshore Installations* [for steel structure only]
- *Rules for Building and Classing Mobile Offshore Drilling Units (MODUs)*
- *Rules for Building and Classing Single Point Moorings (SPMs)*
- *Rules for Building and Classing Floating Production Installations (FPIs)* [for non ship-type hulls].

In case of conflict between the criteria contained in this Guide and the above-mentioned **Rules**, the latter will have precedence.

These criteria are not to be applied to ship-type FPIs, which are being reviewed to receive a *SafeHull*-related Classification Notation. (This includes ship-type FPIs receiving the *SafeHull-Dynamic Load Approach* Classification Notation) In these vessel-related cases, the criteria based on the contents of Part 5C of the *ABS Rules for Building and Classing Steel Vessels (SVR)* apply.

The criteria presented in this Guide may also apply in other situations such as the certification or verification of a structural design for compliance with the Regulations of a Governmental Authority. However, in such a case, the criteria specified by the Governmental Authority should be used, but they may not produce a design that is equivalent to one obtained from the application of the criteria contained in this Guide. Where the mandated technical criteria of the cognizant Governmental Authority for certification differ from those contained herein, ABS will consider the acceptance of such criteria as an alternative to those given herein so that, at the Owner or Operator’s request, both certification and classification may be granted to the Offshore Structure.

ABS welcomes questions on the applicability of the criteria contained herein as they may apply to a specific situation and project.

ABS also appreciates the receipt of comments, suggestions and technical and application questions for the improvement of this Guide. For this purpose, enquiries can be sent electronically to rsd@eagle.org.



GUIDE FOR

**BUCKLING AND ULTIMATE STRENGTH ASSESSMENT
FOR OFFSHORE STRUCTURES**

CONTENTS

SECTION 1	Introduction	1
	1 General	1
	3 Scope of this Guide.....	1
	5 Tolerances and Imperfections.....	1
	7 Corrosion Wastage	2
	9 Loadings.....	2
	11 Maximum Allowable Strength Utilization Factors.....	2
SECTION 2	Individual Structural Members	4
	1 General	4
	1.1 Geometries and Properties of Structural Members.....	4
	1.3 Load Application	4
	1.5 Failure Modes	5
	1.7 Cross Section Classification	10
	1.9 Adjustment Factor.....	10
	3 Members Subjected to a Single Action.....	10
	3.1 Axial Tension	10
	3.3 Axial Compression.....	11
	3.5 Bending Moment.....	13
	5 Members Subjected to Combined Loads.....	15
	5.1 Axial Tension and Bending Moment	15
	5.3 Axial Compression and Bending Moment.....	15
	7 Tubular Members Subjected to Combined Loads with Hydrostatic Pressure.....	17
	7.1 Axial Tension, Bending Moment and Hydrostatic Pressure	17
	7.3 Axial Compression, Bending Moment and Hydrostatic Pressure	17
	9 Local Buckling	19
	9.1 Tubular Members Subjected to Axial Compression.....	19
	9.3 Tubular Members Subjected to Bending Moment.....	19
	9.5 Tubular Members Subjected to Hydrostatic Pressure.....	20
	9.7 Plate Elements Subjected to Compression and Bending Moment.....	21

TABLE 1	Geometries, Properties and Compact Limits of Structural Members	6
TABLE 2	Effective Length Factor	12
TABLE 3	Minimum Buckling Coefficients under Compression and Bending Moment, k_s	22
FIGURE 1	Load Application on a Tubular Member	4
FIGURE 2	Effective Length Factor	13
FIGURE 3	Definition of Edge Stresses.....	21

SECTION 3 Plates, Stiffened Panels and Corrugated Panels..... 23

1	General	23
1.1	Geometry of Plate, Stiffened Panel and Corrugated Panels.....	23
1.3	Load Application.....	25
1.5	Buckling Control Concepts	26
1.7	Adjustment Factor	27
3	Plate Panels	27
3.1	Buckling State Limit.....	27
3.3	Ultimate Strength under Combined In-plane Stresses	30
3.5	Uniform Lateral Pressure.....	31
5	Stiffened Panels	31
5.1	Beam-Column Buckling State Limit	32
5.3	Flexural-Torsional Buckling State Limit	35
5.5	Local Buckling of Web, Flange and Face Plate	37
5.7	Overall Buckling State Limit.....	37
7	Girders and Webs	39
7.1	Web Plate.....	39
7.3	Face Plate and Flange	39
7.5	Large Brackets and Sloping Webs	39
7.7	Tripping Brackets	39
7.9	Effects of Cutouts	40
9	Stiffness and Proportions.....	40
9.1	Stiffness of Stiffeners	40
9.3	Stiffness of Web Stiffeners	41
9.5	Stiffness of Supporting Girders.....	41
9.7	Proportions of Flanges and Faceplates	41
9.9	Proportions of Webs of Stiffeners.....	42
11	Corrugated Panels	42
11.1	Local Plate Panels.....	42
11.3	Unit Corrugation	42
11.5	Overall Buckling	44
13	Geometric Properties	45
13.1	Stiffened Panels	45
13.3	Corrugated Panels	46
FIGURE 1	Typical Stiffened Panel	24
FIGURE 2	Sectional Dimensions of a Stiffened Panel.....	24
FIGURE 3	Typical Corrugated Panel	25

FIGURE 4	Sectional Dimensions of a Corrugated Panel	25
FIGURE 5	Primary Loads and Load Effects on Plate and Stiffened Panel	26
FIGURE 6	Failure Modes ('Levels') of Stiffened Panel	27
FIGURE 7	Unsupported Span of Longitudinal.....	34
FIGURE 8	Effective Breadth of Plating s_w	35
FIGURE 9	Large Brackets and Sloping Webs.....	39
FIGURE 10	Tripping Brackets	39

SECTION 4	Cylindrical Shells.....	47
1	General	47
1.1	Geometry of Cylindrical Shells.....	47
1.3	Load Application	48
1.5	Buckling Control Concepts	48
1.7	Adjustment Factor.....	49
3	Unstiffened or Ring-stiffened Cylinders	50
3.1	Bay Buckling Limit State	50
3.3	Critical Buckling Stress for Axial Compression or Bending Moment.....	50
3.5	Critical Buckling Stress for External Pressure	51
3.7	General Buckling	52
5	Curved Panels	53
5.1	Buckling State Limit	53
5.3	Critical Buckling Stress for Axial Compression or Bending Moment.....	53
5.5	Critical Buckling Stress under External Pressure	54
7	Ring and Stringer-stiffened Shells	55
7.1	Bay Buckling Limit State	55
7.3	Critical Buckling Stress for Axial Compression or Bending Moment.....	56
7.5	Critical Buckling Stress for External Pressure	57
7.7	General Buckling	58
9	Local Buckling Limit State for Ring and Stringer Stiffeners	58
9.1	Flexural-Torsional Buckling	58
9.3	Web Plate Buckling.....	60
9.5	Faceplate and Flange Buckling	60
11	Beam-Column Buckling	60
13	Stress Calculations	61
13.1	Longitudinal Stress	61
13.3	Hoop Stress.....	62
15	Stiffness and Proportions.....	63
15.1	Stiffness of Ring Stiffeners	63
15.3	Stiffness of Stringer Stiffeners	64
15.5	Proportions of Webs of Stiffeners	64
15.7	Proportions of Flanges and Faceplates	64

FIGURE 1	Ring and Stringer-stiffened Cylindrical Shell	47
FIGURE 2	Dimensions of Stiffeners	48
FIGURE 3	Typical Buckling Modes of Ring and Stringer Cylindrical Shells	49
SECTION 5	Tubular Joints	65
1	General	65
1.1	Geometry of Tubular Joints	65
1.3	Loading Application	66
1.5	Failure Modes.....	66
1.7	Classification of Tubular Joints.....	66
1.9	Adjustment Factor	67
3	Simple Tubular Joints	67
3.1	Joint Capacity.....	67
3.3	Joint Cans	69
3.5	Strength State Limit.....	70
5	Other Joints.....	70
5.1	Multipanar Joints	70
5.3	Overlapping Joints.....	71
5.5	Grouted Joints	71
5.7	Ring-Stiffened Joints	72
5.9	Cast Joints.....	72
TABLE 1	Strength Factor, Q_u	68
FIGURE 1	Geometry of Tubular Joints.....	65
FIGURE 2	Examples of Tubular Joint Categoriztion	67
FIGURE 3	Examples of Effective Can Length.....	69
FIGURE 4	Multipanar Joints	70
FIGURE 5	Grouted Joints.....	72
APPENDIX 1	Review of Buckling Analysis by Finite Element Method (FEM)	73
1	General	73
3	Engineering Model	73
5	FEM Analysis Model	74
7	Solution Procedures.....	74
9	Verification and Validation	74

This Page Intentionally Left Blank



SECTION 1 Introduction

1 General (2018)

The criteria in this Guide are primarily based on existing methodologies and their attendant safety factors. These methods and factors are deemed to provide an equivalent level of safety, reflecting what is considered to be appropriate current practice.

It is acknowledged that new methods and criteria for design are constantly evolving. For this reason, ABS does not seek to inhibit the use of an alternative technological approach that is demonstrated to produce an acceptable level of safety.

The criteria in this Guide is presented in the Working Stress Design (WSD) format, also known as the Allowable Stress (or Strength) Design (ASD) format. Alternative structural design criteria in a Load and Resistance Factor Design (LRFD) format are provided in the *ABS Guide for Buckling and Ultimate Strength Assessment of Offshore Structures (LRFD Version)*.

3 Scope of this Guide

This Guide provides criteria that should be used on the following structural steel components or assemblages:

- Individual structural members (i.e., discrete beams and columns) [see Section 2]
- Plates, stiffened panels and corrugated panels [see Section 3]
- Stiffened cylindrical shells [see Section 4]
- Tubular joints [see Section 5]

Additionally, Appendix 1 contains guidance on the review of buckling analysis using the finite element method (FEM) to establish buckling capacities.

5 Tolerances and Imperfections

The buckling and ultimate strength of structural components are highly dependent on the amplitude and shape of the imperfections introduced during manufacture, storage, transportation and installation.

Typical imperfections causing strength deterioration are:

- Initial distortion due to welding and/or other fabrication-related process
- Misalignments of joined components

In general, the effects of imperfections in the form of initial distortions, misalignments and weld-induced residual stresses are implicitly incorporated in the buckling and ultimate strength formulations. Because of their effect on strength, it is important that imperfections be monitored and repaired, as necessary, not only during construction, but also in the completed structure to ensure that the structural components satisfy tolerance limits. The tolerances on imperfections to which the strength criteria given in this Guide are considered valid are listed, for example, in [IACS Recommendation No. 47 “Shipbuilding and Repair Quality Standard”](#). Imperfections exceeding such published tolerances are not acceptable unless it is shown using a recognized method that the strength capacity and utilization factor of the imperfect structural component are within proper target safety levels.

7 Gross Scantlings (2018)

The buckling and ultimate strength formulations provided in this Guide are intended to be used along with the gross scantlings of structural components.

9 Loadings

Conditions representing all modes of operation of the Offshore Structure are to be considered to establish the most critical loading cases. The ABS Rules and Guides for the classification of various types of Offshore Structures typically define two primary loading conditions. In the *ABS Rules for Building and Classing Mobile Offshore Drilling Units (MODU Rules)*, they are ‘Static Loadings’ and ‘Combined Loadings’, and in the *ABS Rules for Building and Classing Offshore Installations (Offshore Installations Rules)*, the *ABS Rules for Building and Classing Single Point Moorings (SPM Rules)* and the *ABS Rules for Building and Classing Floating Production Installations (FPI Rules)* they are ‘Normal Operation’ and ‘Severe Storm’. The component loads of these loading conditions are discussed below. The determination of the magnitudes of each load component and each load effect (i.e., stress, deflection, internal boundary condition, etc.) are to be performed using recognized calculation methods and/or test results and are to be fully documented and referenced. As appropriate, the effects of stress concentrations, secondary stress arising from eccentrically applied loads and member displacements (i.e., P-Δ effects) and additional shear displacements and shear stress in beam elements are to be suitably accounted for in the analysis.

The primary loading conditions to be considered in the *MODU Rules* are:

- i) *Static Loadings*. Stresses due to static loads only, where the static loads include operational gravity loads and the weight of the unit, with the unit afloat or resting on the seabed in calm water.
- ii) *Combined Loadings*. Stresses due to combined loadings, where the applicable static loads, as described above, are combined with relevant environmental loadings, including acceleration and heeling forces.

The primary loading conditions to be considered in the *Offshore Installations Rules*, *SPM Rules* and *FPI Rules* are:

- i) *Normal Operations*. Stresses due to operating environmental loading combined with dead and maximum live loads appropriate to the function and operations of the structure
- ii) *Severe Storm*. Stresses due to design environmental loading combined with dead and live loads appropriate to the function and operations of the structure during design environmental condition

The buckling and ultimate strength formulations in this Guide are applicable to static/quasi-static loads, Dynamic (e.g., impulsive) loads, such as may result from impact and fluid sloshing, can induce ‘dynamic buckling’, which, in general, is to be dealt with using an appropriate nonlinear analysis.

11 Maximum Allowable Strength Utilization Factors

The buckling and ultimate strength equations in this Guide provide an estimate of the average strength of the considered components while achieving the lowest standard deviation when compared with nonlinear analyses and mechanical tests. To ensure the safety of the structural components, maximum allowable strength utilization factors, which are the inverse of safety factors, are applied to the predicted strength. The maximum allowable strength utilization factors will, in general, depend on the given loading condition, the type of structural component and the failure consequence.

The maximum allowable strength utilization factors, η , are based on the factors of safety given in the *Offshore Installations Rules*, *MODU Rules*, *SPM Rules* and *FPI Rules*, as applicable. The maximum allowable strength utilization factors have the following values.

- i) For a loading condition that is characterized as a *static loading* of a Mobile Offshore Drilling Unit or *normal operation* of an Offshore Installation, Floating Production Installation and Single Point Mooring:

$$\eta = 0.60\psi$$

- ii) For a loading condition that is characterized as a *combined loading* of a Mobile Offshore Drilling Unit or *severe storm* of an Offshore Installation, Floating Production Installation and Single Point Mooring:

$$\eta = 0.80\psi$$

where

ψ = adjustment factor, as given in subsequent sections of this Guide.

Under the above-mentioned Rules and Guides, it is required that both of the characteristic types of loading conditions (i.e., static and combined, or normal operation and severe storm) are to be applied in the design and assessment of a structure. The loading condition producing the most severe requirement governs the design.

In the Sections that follow concerning specific structural components, different adjustment factors may apply to different types of loading (i.e., tension or bending versus pure compression). To represent the values of η applicable to the different types of load components, subscripts are sometimes added to the symbol η (e.g., in Section 2, η_1 and η_2 , apply, respectively, to axial compression or tension/bending in the individual structural member.).

SECTION 2 Individual Structural Members

1 General

This Section provides strength criteria for individual structural members. The types of members considered in this Section are tubular and non-tubular members with uniform geometric properties along their entire length and made of a single material. The criteria provided in this Section are for tubular and non-tubular elements, but other recognized standards are also acceptable.

The behavior of structural members is influenced by a variety of factors, including sectional shape, material characteristics, boundary conditions, loading types and parameters and fabrication methods.

1.1 Geometries and Properties of Structural Members

A structural member with a cross section having at least one axis of symmetry is considered. The geometries and properties of some typical cross sections are illustrated in Section 2, Table 1. For sections which are not listed in Section 2, Table 1, the required geometric properties are to be calculated based on acceptable formulations.

1.3 Load Application

This Section includes the strength criteria for any of the following loads and load effects:

- Axial force in longitudinal direction, P
- Bending moment, M
- Hydrostatic pressure, q
- Combined axial tension and bending moment
- Combined axial compression and bending moment
- Combined axial tension, bending moment and hydrostatic pressure
- Combined axial compression, bending moment and hydrostatic pressure

The load directions depicted in Section 2, Figure 1 are positive.

FIGURE 1
Load Application on a Tubular Member

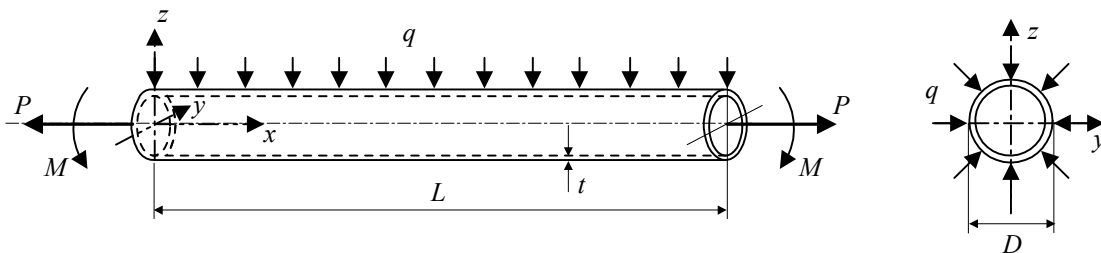

1.5 Failure Modes

Failure modes for a structural member are categorized as follows:

- *Flexural buckling.* Bending about the axis of the least resistance.
- *Torsional buckling.* Twisting about the longitudinal (x) axis. It may occur if the torsional rigidity of the section is low, as for a member with a thin-walled open cross section.
- *Lateral-torsional buckling.* Synchronized bending and twisting. A member which is bent about its major axis may buckle laterally.
- *Local buckling.* Buckling of a plate or shell element that is a local part of a member

TABLE 1
Geometries, Properties and Compact Limits of Structural Members

<i>Geometry</i>	<i>Sectional Shape</i>	<i>Geometrical Parameters</i>	<i>Axis</i>	<i>Properties*</i>	<i>Compact Limits</i>
1. Tubular member		D = Outer diameter t = Thickness	N/A	$A = \pi[D^2 - (D - 2t)^2]/4$ $I_y, I_z = \pi[D^4 - (D - 2t)^4]/64$ $K = \pi(D - t)^3 t/4$ $I_o = \pi[D^4 - (D - 2t)^4]/32$ $\Gamma = 0$	$\frac{D}{t} \leq \frac{E}{9\sigma_0}$
2. Square or rectangular hollow section		b = Flange width d = Web depth t = Thickness	Major y-y Minor z-z	$A = 2(b + d)t$ $I_y = d^2 t(3b + d)/6$ $I_z = b^2 t(b + 3d)/6$ $K = \frac{2b^2 d^2 t}{b + d}$ $I_o = t(b + d)^3/6$ $\Gamma = \frac{b^2 d^2 t (d - b)^2}{24 (b + d)}$	$\frac{b}{t}, \frac{d}{t} \leq 1.5 \sqrt{\frac{E}{\sigma_0}}$

TABLE 1 (continued)
Geometries, Properties and Compact Limits of Structural Members

Geometry	Sectional Shape	Geometrical Parameters	Axis	Properties*	Compact Limits
3. Welded box shape		<p> d = Web depth t_w = Web thickness b = Flange width t_f = Flange thickness b_2 = Outstand </p>	<p> Major y-y Minor z-z </p>	<p> $A = 2(bt_f + dt_w)$ $I_y = d^2(3bt_f + dt_w)/6$ $I_z = b^2(bt_f + 3dt_w)/6$ $K = \frac{2a^2d^2}{\left(\frac{a}{t_f} + \frac{d}{t_w}\right)}$ $I_o = I_y + I_z$ $\Gamma = \frac{(b^3d^2t_f - a^2d^3t_w)^2}{24(b^3d^2t_f + a^2d^3t_w)}$ </p>	<p> $\frac{a}{t_f}, \frac{d}{t_w} \leq 1.5 \sqrt{\frac{E}{\sigma_0}}$ $\frac{b_2}{t_f} \leq 0.4 \sqrt{\frac{E}{\sigma_0}}$ </p>
4. W-shape		<p> d = Web depth t_w = Web thickness b = Flange width t_f = Flange thickness </p>	<p> Major y-y Minor z-z </p>	<p> $A = 2bt_f + dt_w$ $I_y = d^2(6bt_f + dt_w)/12$ $I_z = b^3t_f/6$ $K = (2bt_f^3 + dt_w^3)/3$ $I_o = I_y + I_z$ $\Gamma = d^2b^3t_f/24$ </p>	<p> $\frac{d}{t_w} \leq 1.5 \sqrt{\frac{E}{\sigma_0}}$ $\frac{b}{t_f} \leq 0.8 \sqrt{\frac{E}{\sigma_0}}$ </p>

TABLE 1 (continued)
Geometries, Properties and Compact Limits of Structural Members

<i>Geometry</i>	<i>Sectional Shape</i>	<i>Geometrical Parameters</i>	<i>Axis</i>	<i>Properties*</i>	<i>Compact Limits</i>
5. Channel		d = Web depth t_w = Web thickness b = Flange width t_f = Flange thickness d_{cs} = Distance of shear center to centroid	Major y-y Minor z-z	$A = 2bt_f + dt_w$ $I_y = d^2(6bt_f + dt_w)/12$ $I_z = d^3t_w(bt_f + 2dt_w)/3A$ $K = (2bt_f^3 + dt_w^3)/3$ $I_o = I_y + I_z + Ad_{cs}^2$ $\Gamma = \frac{d^2b^3t_f(3bt_f + 2dt_w)}{12(6bt_f + dt_w)}$	$\frac{d}{t_w} \leq 1.5 \sqrt{\frac{E}{\sigma_0}}$ $\frac{b}{t_f} \leq 0.4 \sqrt{\frac{E}{\sigma_0}}$
6. T-bar		d = Web depth t_w = Web thickness b = Flange width t_f = Flange thickness d_{cs} = Distance of shear center to centroid	Major y-y Minor z-z	$A = bt_f + dt_w$ $I_y = d^3t_w(4bt_f + dt_w)/12A$ $I_z = b^3t_f/12$ $K = (bt_f^3 + dt_w^3)/3$ $I_o = I_y + I_z + Ad_{cs}^2$ $\Gamma = (b^3t_f^3 + 4d^3t_w^3)/144$	$\frac{d}{t_w} \leq 0.4 \sqrt{\frac{E}{\sigma_0}}$ $\frac{b}{t_f} \leq 0.8 \sqrt{\frac{E}{\sigma_0}}$

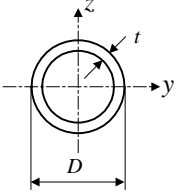
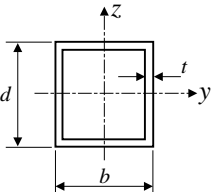
TABLE 1 (continued)
Geometries, Properties and Compact Limits of Structural Members

<i>Geometry</i>	<i>Sectional Shape</i>	<i>Geometrical Parameters</i>	<i>Axis</i>	<i>Properties*</i>	<i>Compact Limits</i>
7. Double angles		d = Web depth t_w = Web thickness b = Flange width t_f = Flange thickness d_{cs} = Distance of shear center to centroid	Major y-y Minor z-z	$A = 2(bt_f + dt_w)$ $I_y = d^3 t_w (4bt_f + dt_w) / 3A$ $I_z = 2b^3 t_f / 3$ $K = 2(bt_f^3 + dt_w^3) / 3$ $I_o = I_y + I_z + A d_{cs}^2$ $\Gamma = (b^3 t_f^3 + 4d^3 t_w^3) / 18$	$\frac{d}{t_w} \leq 0.4 \sqrt{\frac{E}{\sigma_0}}$ $\frac{b}{t_f} \leq 0.4 \sqrt{\frac{E}{\sigma_0}}$

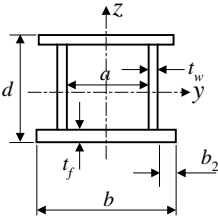
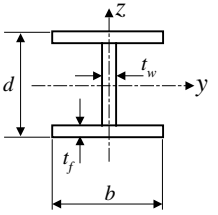
* The formulations for the properties are derived assuming that the section is thin-walled (i.e., thickness is relatively small) where:

- A = cross sectional area, cm^2 (in^2)
- I_y = moment of inertia about y-axis, cm^4 (in^4)
- I_z = moment of inertia about z-axis, cm^4 (in^4)
- K = St. Venant torsion constant for the member, cm^4 (in^4)
- I_o = polar moment of inertia of the member, cm^4 (in^4)
- Γ = warping constant, cm^6 (in^6)

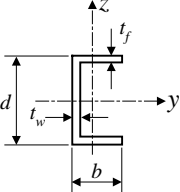
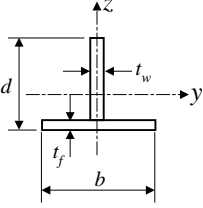
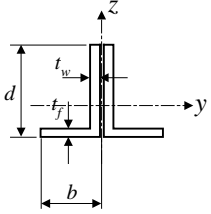
1.7 Cross Section Classification

The cross section may be classified as:

- i) *Compact.* A cross section is compact if all compressed components comply with the limits in Section 2, Table 1. For a compact section, the local buckling (plate buckling and shell buckling) can be disregarded because yielding precedes buckling.
- ii) *Non-Compact.* A cross section is non-compact if any compressed component does not comply with the limits in Section 2, Table 1. For a non-compact section, the local buckling (plate or shell buckling) is to be taken into account.

1.9 Adjustment Factor

For the maximum allowable strength utilization factors, η , defined in Subsection 1/11, the adjustment factor is to take the following values:

For axial tension and bending [to establish η_2 below]:

$$\psi = 1.0$$

For axial compression (column buckling or torsional buckling) [to establish η_1 below]:

$$\begin{aligned} \psi &= 0.87 && \text{if } \sigma_{EA} \leq P_r \sigma_0 \\ &= 1 - 0.13 \sqrt{P_r \sigma_0 / \sigma_{EA}} && \text{if } \sigma_{EA} > P_r \sigma_0 \end{aligned}$$

where

$$\begin{aligned} \sigma_{EA} &= \text{elastic buckling stress, as defined in 2/3.3, N/cm}^2 \text{ (kgf/cm}^2 \text{, lbf/in}^2\text{)} \\ P_r &= \text{proportional linear elastic limit of the structure, which may be taken as 0.6 for steel} \\ \sigma_0 &= \text{specified minimum yield point, N/cm}^2 \text{ (kgf/cm}^2 \text{, lbf/in}^2\text{)} \end{aligned}$$

For compression (local buckling of tubular members) [to establish η_x and η_θ below]:

$$\begin{aligned} \psi &= 0.833 && \text{if } \sigma_{Ci} \leq 0.55 \sigma_0 \\ &= 0.629 + 0.371 \sigma_{Ci} / \sigma_0 && \text{if } \sigma_{Ci} > 0.55 \sigma_0 \end{aligned}$$

where

$$\begin{aligned} \sigma_{Ci} &= \text{critical local buckling stress, representing } \sigma_{Ci} \text{ for axial compression, as specified in 2/9.1, and } \sigma_{C\theta} \text{ for hydrostatic pressure, as specified in 2/9.5, N/cm}^2 \text{ (kgf/cm}^2 \text{, lbf/in}^2\text{)} \\ \sigma_0 &= \text{specified minimum yield point, N/cm}^2 \text{ (kgf/cm}^2 \text{, lbf/in}^2\text{)} \end{aligned}$$

3 Members Subjected to a Single Action

3.1 Axial Tension

Members subjected to axial tensile forces are to satisfy the following equation:

$$\sigma_t / \eta_2 \sigma_0 \leq 1$$

where

$$\begin{aligned} \sigma_t &= \text{axial tensile stress, N/cm}^2 \text{ (kgf/cm}^2 \text{, lbf/in}^2\text{)} \\ &= P/A \\ \sigma_0 &= \text{specified minimum yield point, N/cm}^2 \text{ (kgf/cm}^2 \text{, lbf/in}^2\text{)} \\ P &= \text{axial force, N (kgf, lbf)} \\ A &= \text{cross sectional area, cm}^2 \text{ (in}^2\text{)} \\ \eta_2 &= \text{allowable strength utilization factor for tension and bending, as defined in Subsection 1/11 and 2/1.9} \end{aligned}$$

3.3 Axial Compression

Members subjected to axial compressive forces may fail by flexural or torsional buckling. The buckling limit state is defined by the following equation:

$$\sigma_A / \eta_1 \sigma_{CA} \leq 1$$

where

$$\begin{aligned} \sigma_A &= \text{axial compressive stress, N/cm}^2 \text{ (kgf/cm}^2 \text{, lbf/in}^2\text{)} \\ &= -P/A \end{aligned}$$

$$P = \text{axial force, N (kgf, lbf)}$$

$$\sigma_{CA} = \text{critical buckling stress, N/cm}^2 \text{ (kgf/cm}^2 \text{, lbf/in}^2\text{)}$$

$$= \begin{cases} \sigma_{EA} & \text{if } \sigma_{EA} \leq P_r \sigma_F \\ \sigma_F \left[1 - P_r (1 - P_r) \frac{\sigma_F}{\sigma_{EA}} \right] & \text{if } \sigma_{EA} > P_r \sigma_F \end{cases}$$

$$P_r = \text{proportional linear elastic limit of the structure, which may be taken as 0.6 for steel}$$

$$\sigma_F = \sigma_0 \quad \text{specified minimum yield point for a compact section}$$

$$= \sigma_{Cx} \quad \text{local buckling stress for a non-compact section from Subsection 2/9}$$

$$\sigma_{EA} = \text{elastic buckling stress, which is the lesser of the solutions of the following quadratic equation, N/cm}^2 \text{ (kgf/cm}^2 \text{, lbf/in}^2\text{)}$$

$$\frac{I_0}{A} (\sigma_{EA} - \sigma_{E\eta}) (\sigma_{EA} - \sigma_{ET}) - \sigma_{EA}^2 d_{cs}^2 = 0$$

$$\sigma_{E\eta} = \text{Euler buckling stress about minor axis, N/cm}^2 \text{ (kgf/cm}^2 \text{, lbf/in}^2\text{)}$$

$$= \pi^2 E / (kL/r_\eta)^2$$

$$\sigma_{ET} = \text{ideal elastic torsional buckling stress, N/cm}^2 \text{ (kgf/cm}^2 \text{, lbf/in}^2\text{)}$$

$$= \frac{EK}{2.6I_0} + \left(\frac{\pi}{kL} \right)^2 \frac{E\Gamma}{I_0}$$

$$r_\eta = \text{radius of gyration about minor axis, cm (in.)}$$

$$= \sqrt{I_\eta / A}$$

$$E = \text{modulus of elasticity, } 2.06 \times 10^7 \text{ N/cm}^2 \text{ (} 2.1 \times 10^6 \text{ kgf/cm}^2 \text{, } 30 \times 10^6 \text{ lbf/in}^2\text{) for steel}$$

$$A = \text{cross sectional area, cm}^2 \text{ (in}^2\text{)}$$

$$I_\eta = \text{moment of inertia about minor axis, cm}^4 \text{ (in}^4\text{)}$$

$$K = \text{St. Venant torsion constant for the member, cm}^4 \text{ (in}^4\text{)}$$

$$I_0 = \text{polar moment of inertia of the member, cm}^4 \text{ (in}^4\text{)}$$

$$\Gamma = \text{warping constant, cm}^6 \text{ (in}^6\text{)}$$

$$d_{cs} = \text{difference of centroid and shear center coordinates along major axis, cm (in.)}$$

$$L = \text{member's length, cm (in.)}$$

$$k = \text{effective length factor, as specified in Section 2, Table 2. When it is difficult to clarify the end conditions, the nomograph shown in Section 2, Figure 2 may be used. The values of } G \text{ for each end (A and B) of the column are determined:}$$

$$G = \sum \frac{I_c}{L_c} / \sum \frac{I_g}{L_g}$$

$\sum \frac{I_c}{L_c}$ is the total for columns meeting at the joint considered and $\sum \frac{I_g}{L_g}$ is the total

for restraining beams meeting at the joint considered. For a column end that is supported, but not fixed, the moment of inertia of the support is zero, and the resulting value of G for this end of the column would be ∞ . However, in practice, unless the footing was designed as a frictionless pin, this value of G would be taken as 10. If the column end is fixed, the moment of inertia of the support would be ∞ , and the resulting value of G of this end of the column would be zero. However, in practice, there is some movement and G may be taken as 1.0. If the restraining beam is either pinned ($G = \infty$) or fixed ($G = 0$) at its far end, refinements may be made by multiplying the stiffness (I_g/L_g) of the beam by the following factors:

Sidesway prevented

Far end of beam pinned = 1.5

Sidesway permitted

Far end of beam pinned = 0.5

Far end of beam fixed = 2.0

η_1 = allowable strength utilization factor for axial compression (column buckling), as defined in Subsection 1/11 and 2/1.9

TABLE 2
Effective Length Factor

Buckled shape of column shown by dashed line						
Theoretical value	0.50	0.70	1.0	1.0	2.0	2.0
Recommended k value when ideal conditions are approximated	0.65	0.80	1.2	1.0	2.1	2.0
End condition notation		Rotation fixed. Translation fixed				
		Rotation free. Translation fixed				
		Rotation fixed. Translation free				
		Rotation free. Translation free				

FIGURE 2
Effective Length Factor

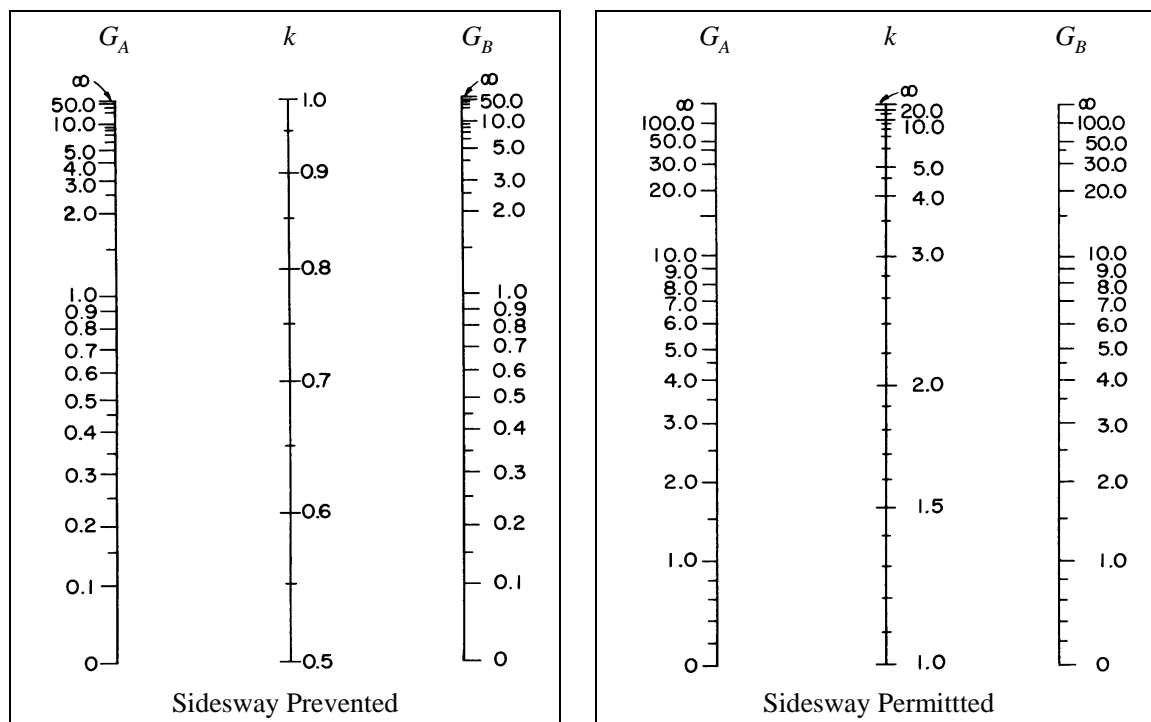

Note: These alignment charts or nomographs are based on the following assumptions:

- 1 Behavior is purely elastic.
- 2 All members have constant cross section.
- 3 All joints are rigid.
- 4 For columns in frames with sidesway prevented, rotations at opposite ends of the restraining beams are equal in magnitude and opposite in direction, producing single curvature bending.
- 5 For columns in frames with sidesway permitted, rotations at opposite ends of the restraining beams are equal in magnitude and direction, producing reverse curvature bending.
- 6 The stiffness parameter $L(P/EI)^{1/2}$ of all columns is equal.
- 7 Joint restraint is distributed to the column above and below the joint in proportion to EI/L for the two columns.
- 8 All columns buckle simultaneously.
- 9 No significant axial compression force exists in the restraining beams.

Adjustments are required when these assumptions are violated and the alignment charts are still to be used. Reference is made to ANSI/AISC 360-05, Commentary C2.

3.5 Bending Moment

A member subjected to **bending moment** may fail by local buckling or lateral-torsional buckling. The buckling state limit is defined by the following equation:

$$\sigma_b / \eta_2 \sigma_{CB} \leq 1$$

where

$$\begin{aligned} \sigma_b &= \text{stress due to bending moment} \\ &= M / S M_e \end{aligned}$$

- M = bending moment, N-cm (kgf-cm, lbf-in)
- SM_e = elastic section modulus, cm³ (in³)
- η_2 = allowable strength utilization factor for tension and bending
- σ_{CB} = critical bending strength, as follows:
- i) For a tubular member, the critical bending strength is to be obtained from the equation given in 2/9.3.
 - ii) For a rolled or fabricated-plate section, the critical bending strength is determined by the critical lateral-torsional buckling stress.

The critical lateral-torsional buckling stress is to be obtained from the following equation:

$$\sigma_{C(LT)} = \begin{cases} \sigma_{E(LT)} & \text{if } \sigma_{E(LT)} \leq P_r \sigma_F \\ \sigma_F \left[1 - P_r (1 - P_r) \frac{\sigma_F}{\sigma_{E(LT)}} \right] & \text{if } \sigma_{E(LT)} > P_r \sigma_F \end{cases}$$

P_r = proportional linear elastic limit of the structure, which may be taken as 0.6 for steel

$\sigma_{E(LT)}$ = elastic lateral-torsional buckling stress, N/cm² (kgf/cm², lbf/in²)

$$= \sqrt{C} \frac{\pi^2 EI_\eta}{SM_c (kL)^2}$$

I_η = moment of inertia about minor axis, as defined in Section 2, Table 1, cm⁴ (in⁴)

SM_e = section modulus of compressive flange, cm³ (in³)

$$= \frac{I_\xi}{\xi_c}$$

I_ξ = moment of inertia about major axis, as defined in Section 2, Table 1, cm⁴ (in⁴)

ξ_c = distance from major neutral axis to compressed flange, cm (in.)

$$C = \frac{\Gamma}{I_\eta} + \frac{K}{I_\eta} \frac{(kL)^2}{2.6\pi^2}$$

E = modulus of elasticity, 2.06 × 10⁷ N/cm² (2.1 × 10⁶ kgf/cm², 30 × 10⁶ lbf/in²) for steel

σ_F = σ_0 , specified minimum yield point for a compact section

= σ_{Cx} , local buckling stress for a non-compact section, as specified in 2/9.7

K = St. Venant torsion constant for the member, cm⁴ (in⁴)

Γ = warping constant, cm⁶ (in⁶)

L = member's length, cm (in.)

k = effective length factor, as defined in 2/3.3

5 Members Subjected to Combined Loads

5.1 Axial Tension and Bending Moment

Members subjected to combined axial tension and bending moment are to satisfy the following equations at all cross-sections along their length:

For tubular members:

$$\frac{\sigma_t}{\eta_2 \sigma_0} + \frac{1}{\eta_2} \left[\left(\frac{\sigma_{by}}{\sigma_{CB_y}} \right)^2 + \left(\frac{\sigma_{bz}}{\sigma_{CB_z}} \right)^2 \right]^{0.5} \leq 1$$

For rolled or fabricated-plate sections:

$$\frac{\sigma_t}{\eta_2 \sigma_0} + \frac{\sigma_{by}}{\eta_2 \sigma_{CB_y}} + \frac{\sigma_{bz}}{\eta_2 \sigma_{CB_z}} \leq 1$$

where

- σ_t = axial tensile stress from 2/3.1, N/cm² (kgf/cm², lbf/in²)
- σ_{by} = bending stress from 2/3.5 about member y-axis, N/cm² (kgf/cm², lbf/in²)
- σ_{bz} = bending stress from 2/3.5 about member z-axis, N/cm² (kgf/cm², lbf/in²)
- σ_{CB_y} = critical bending strength corresponding to member's y-axis from 2/3.5, N/cm² (kgf/cm², lbf/in²)
- σ_{CB_z} = critical bending strength corresponding to member's z-axis from 2/3.5, N/cm² (kgf/cm², lbf/in²)
- η_2 = allowable strength utilization factor for tension and bending, as defined in 1/11 and 2/1.9

5.3 Axial Compression and Bending Moment

Members subjected to combined axial compression and bending moment are to satisfy the following equation at all cross sections along their length:

For tubular members:

When $\sigma_a/\sigma_{CA} > 0.15$:

$$\frac{\sigma_a}{\eta_1 \sigma_{CA}} + \frac{1}{\eta_2} \left\{ \left[\frac{1}{\sigma_{CB_y}} \frac{C_{my} \sigma_{by}}{1 - \sigma_a / (\eta_1 \sigma_{Ey})} \right]^2 + \left[\frac{1}{\sigma_{CB_z}} \frac{C_{mz} \sigma_{bz}}{1 - \sigma_a / (\eta_1 \sigma_{Ez})} \right]^2 \right\}^{0.5} \leq 1$$

When $\sigma_a/\sigma_{CA} \leq 0.15$:

$$\frac{\sigma_a}{\eta_1 \sigma_{CA}} + \frac{1}{\eta_2} \left[\left(\frac{\sigma_{by}}{\sigma_{CB_y}} \right)^2 + \left(\frac{\sigma_{bz}}{\sigma_{CB_z}} \right)^2 \right]^{0.5} \leq 1$$

For rolled or fabricated-plate sections:

When $\sigma_a/\sigma_{CA} > 0.15$:

$$\frac{\sigma_a}{\eta_1 \sigma_{CA}} + \frac{1}{\eta_2 \sigma_{CB_y}} \frac{C_{my} \sigma_{by}}{1 - \sigma_a / (\eta_1 \sigma_{Ey})} + \frac{1}{\eta_2 \sigma_{CB_z}} \frac{C_{mz} \sigma_{bz}}{1 - \sigma_a / (\eta_1 \sigma_{Ez})} \leq 1$$

When $\sigma_a/\sigma_{CA} \leq 0.15$:

$$\frac{\sigma_a}{\eta_1 \sigma_{CA}} + \frac{\sigma_{by}}{\eta_2 \sigma_{CB_y}} + \frac{\sigma_{bz}}{\eta_2 \sigma_{CB_z}} \leq 1$$

where

- σ_a = axial compressive stress from 2/3.3, N/cm² (kgf/cm², lbf/in²)
 σ_{by} = bending stress from 2/3.5 about member y-axis, N/cm² (kgf/cm², lbf/in²)
 σ_{bz} = bending stress from 2/3.5 about member z-axis, N/cm² (kgf/cm², lbf/in²)
 σ_{CA} = critical axial compressive strength from 2/3.3, N/cm² (kgf/cm², lbf/in²)
 σ_{CB_y} = critical bending strength corresponding to member y-axis from 2/3.5, N/cm² (kgf/cm², lbf/in²)
 σ_{CB_z} = critical bending strength corresponding to member z-axis from 2/3.5, N/cm² (kgf/cm², lbf/in²)
 σ_{E_y} = Euler buckling stress corresponding to member y-axis, N/cm² (kgf/cm², lbf/in²)
 $\quad = \pi^2 E / (k_y L / r_y)^2$
 σ_{E_z} = Euler buckling stress corresponding to member z-axis, N/cm² (kgf/cm², lbf/in²)
 $\quad = \pi^2 E / (k_z L / r_z)^2$
 E = modulus of elasticity, 2.06 × 10⁷ N/cm² (2.1 × 10⁶ kgf/cm², 30 × 10⁶ lbf/in²) for steel
 r_y, r_z = radius of gyration corresponding to the member y- and z-axes, cm (in.)
 k_y, k_z = effective length factors corresponding to member y- and z-axes from 2/3.3
 C_{m_y}, C_{m_z} = moment factors corresponding to the member y- and z-axes, as follows:
 - i) For compression members in frames subjected to joint translation (sidesway):

$$C_m = 0.85$$
 - ii) For restrained compression members in frames braced against joint translation (sidesway) and with no transverse loading between their supports:

$$C_m = 0.6 - 0.4M_1/M_2$$

but not less than 0.4 and limited to 0.85, where M_1/M_2 is the ratio of smaller to larger moments at the ends of that portion of the member unbraced in the plane of bending under consideration. M_1/M_2 is positive when the member is bent in reverse curvature, negative when bent in single curvature.
 - iii) For compression members in frames braced against joint translation in the plane of loading and subject to transverse loading between their supports, the value of C_m may be determined by rational analysis. However, in lieu of such analysis, the following values may be used.
For members whose ends are restrained:

$$C_m = 0.85$$

For members whose ends are unrestrained:

$$C_m = 1.0$$
- η_1 = allowable strength utilization factor for axial compression (column buckling), as defined in Subsection 1/11 and 2/1.9
 η_2 = allowable strength utilization factor for tension and bending, as defined in Subsection 1/11 and 2/1.9

7 Tubular Members Subjected to Combined Loads with Hydrostatic Pressure

Appropriate consideration is to be given to the *capped-end actions* on a structural member subjected to hydrostatic pressure. It should be noted that the equations in this Subsection do not apply unless the criteria of 2/9.5 are satisfied first.

7.1 Axial Tension, Bending Moment and Hydrostatic Pressure

The following equation is to be satisfied for tubular members subjected to combined axial tension, bending moment and hydrostatic pressure:

$$\frac{\sigma_{tc}}{\eta_2 \sigma_{T\theta}} + \frac{\sqrt{\sigma_{by}^2 + \sigma_{bz}^2}}{\eta_2 \sigma_{CB\theta}} \leq 1$$

where

- σ_{tc} = calculated **axial tensile** stress due to forces from actions that include the capped-end actions due to hydrostatic pressure, N/cm² (kgf/cm², lbf/in²)
- $\sigma_{T\theta}$ = axial tensile strength in the presence of hydrostatic pressure, N/cm² (kgf/cm², lbf/in²)
= $C_q \sigma_0$
- $\sigma_{CB\theta}$ = bending strength in the presence of hydrostatic pressure, N/cm² (kgf/cm², lbf/in²)
= $C_q \sigma_{CB}$
- σ_{CB} = critical bending strength excluding hydrostatic pressure from 2/3.5
- C_q = $[\sqrt{1 + 0.09B^2} - B^{2\xi} - 0.3B]$
- B = $\sigma_\theta / (\eta_\theta \sigma_{C\theta})$
- ξ = $5 - 4\sigma_{C\theta} / \sigma_0$
- σ_θ = hoop stress due to hydrostatic pressure from 2/9.5, N/cm² (kgf/cm², lbf/in²)
- $\sigma_{C\theta}$ = critical hoop buckling strength from 2/9.5, N/cm² (kgf/cm², lbf/in²)
- σ_0 = specified minimum yield point, N/cm² (kgf/cm², lbf/in²)
- η_2 = allowable strength utilization factor for tension and bending, as defined in Subsection 1/11 and 2/1.9
- η_θ = allowable strength utilization factor for local buckling in the presence of hydrostatic pressure, as defined in Subsection 1/11 and 2/1.9

7.3 Axial Compression, Bending Moment and Hydrostatic Pressure

Tubular members subjected to combined compression, bending moment and external pressure are to satisfy the following equations at all cross sections along their length.

When $\sigma_{ac} / \sigma_{CA\theta} > 0.15$ and $\sigma_{ac} > 0.5\sigma_\theta$:

$$\frac{\sigma_{ac} - 0.5\sigma_\theta}{\eta_1 \sigma_{CA\theta}} + \frac{1}{\eta_2 \sigma_{CB\theta}} \left\{ \left[\frac{C_{my} \sigma_{by}}{1 - \frac{\sigma_{ac} - 0.5\sigma_\theta}{\eta_1 \sigma_{Ey}}} \right]^2 + \left[\frac{C_{mz} \sigma_{bz}}{1 - \frac{\sigma_{ac} - 0.5\sigma_\theta}{\eta_1 \sigma_{Ez}}} \right]^2 \right\}^{0.5} \leq 1$$

When $\sigma_{ac}/\sigma_{CA\theta} \leq 0.15$:

$$\frac{\sigma_a}{\eta_1 \sigma_{CA\theta}} + \frac{1}{\eta_2} \left[\left(\frac{\sigma_{by}}{\sigma_{CB\theta}} \right)^2 + \left(\frac{\sigma_{bz}}{\sigma_{CB\theta}} \right)^2 \right]^{0.5} \leq 1$$

where

- σ_{ac} = calculated compressive axial stress due to axial compression that includes the capped-end actions due to hydrostatic pressure, N/cm² (kgf/cm², lbf/in²)
- σ_{θ} = hoop stress due to hydrostatic pressure from 2/9.5, N/cm² (kgf/cm², lbf/in²)
- $\sigma_{CB\theta}$ = critical bending strength in the presence of hydrostatic pressure from 2/7.1, N/cm² (kgf/cm², lbf/in²)
- $\sigma_{CA\theta}$ = axial compressive strength in the presence of hydrostatic pressure
 $= \begin{cases} \sigma_{EA} & \text{if } \sigma_{EA} \leq P_r \sigma_F (1 - \sigma_{\theta} / \sigma_F) \\ \sigma_F \Lambda & \text{if } \sigma_{EA} > P_r \sigma_F (1 - \sigma_{\theta} / \sigma_F) \end{cases}$
- σ_{EA} = elastic buckling stress in the absence of hydrostatic pressure from 2/3.3, N/cm² (kgf/cm², lbf/in²)
- Λ = $(\zeta + \sqrt{\zeta^2 + 4\omega}) / 2$
- ζ = $1 - P_r(1 - P_r)\sigma_F/\sigma_{EA} - \sigma_{\theta}/\sigma_F$
- ω = $0.5(\sigma_{\theta}/\sigma_F)(1 - 0.5\sigma_{\theta}/\sigma_F)$
- σ_{Ey} = Euler buckling stress corresponding to member y-axis from 2/5.3, N/cm² (kgf/cm², lbf/in²)
- σ_{Ez} = Euler buckling stress corresponding to member z-axis from 2/5.3, N/cm² (kgf/cm², lbf/in²)
- C_{my}, C_{mz} = moment factors corresponding to the member y- and z-axes from 2/5.3
- P_r = proportional linear elastic limit of the structure, which may be taken as 0.6 for steel
- E = modulus of elasticity, 2.06×10^7 N/cm² (2.1×10^6 kgf/cm², 30×10^6 lbf/in²) for steel
- σ_F = σ_0 , specified minimum yield point for the compact section
 $= \sigma_{Cx}$, local buckling stress for the non-compact section from 2/9.7
- η_1 = allowable strength utilization factor for axial compression (column buckling), as defined in Subsection 1/11 and 2/1.9
- η_2 = allowable strength utilization factor for tension and bending, as defined in Subsection 1/11 and 2/1.9

When $\sigma_x > 0.5\eta_{\theta}\sigma_{C\theta}$ and $\eta_x\sigma_x > 0.5\eta_{\theta}\sigma_{C\theta}$ the following equation is to also be satisfied:

$$\frac{\sigma_x - 0.5\eta_{\theta}\sigma_{C\theta}}{\eta_x\sigma_{Cx} - 0.5\eta_{\theta}\sigma_{C\theta}} + \left[\frac{\sigma_{\theta}}{\eta_{\theta}\sigma_{C\theta}} \right]^2 \leq 1$$

where

- σ_x = maximum compressive axial stress from axial compression and bending moment, which includes the capped-end actions due to the hydrostatic pressure, N/cm² (kgf/cm², lbf/in²)
 $= \sigma_{ac} + \sigma_b$
- σ_{ac} = calculated compressive axial stress due to axial compression from actions that include the capped-end actions due to hydrostatic pressure, N/cm² (kgf/cm², lbf/in²)

σ_b	=	stress due to bending moment from 2/3.5, N/cm ² (kgf/cm ² , lbf/in ²)
σ_{Cx}	=	critical axial buckling stress from 2/9.1, N/cm ² (kgf/cm ² , lbf/in ²)
$\sigma_{C\theta}$	=	critical hoop buckling stress from 2/9.5, N/cm ² (kgf/cm ² , lbf/in ²)
C_{my}, C_{mz}	=	moment factors corresponding to the member y- and z-axes, as defined in 2/5.3
η_x	=	maximum allowable strength utilization factor for axial compression (local buckling), as defined in Subsection 1/11 and 2/1.9
η_θ	=	maximum allowable strength utilization factor for hydrodynamic pressure (local buckling), as defined in Subsection 1/11 and 2/1.9

9 Local Buckling

For a member with a non-compact section, local buckling may occur before the member as a whole becomes unstable or before the yield point of the material is reached. Such behavior is characterized by local distortion of the cross section of the member. When a detailed analysis is not available, the equations given below may be used to evaluate the local buckling stress of a member with a non-compact section.

9.1 Tubular Members Subjected to Axial Compression

Local buckling stress of tubular members with $D/t \leq E/(4.5\sigma_0)$ subjected to axial compression may be obtained from the following equation:

$$\sigma_{Cx} = \begin{cases} \sigma_{Ex} & \text{if } \sigma_{Ex} \leq P_r \sigma_0 \\ \sigma_0 \left[1 - P_r (1 - P_r) \frac{\sigma_0}{\sigma_{Ex}} \right] & \text{if } \sigma_{Ex} > P_r \sigma_0 \end{cases}$$

where

P_r	=	proportional linear elastic limit of the structure, which may be taken as 0.6 for steel
σ_0	=	specified minimum yield point, N/cm ² (kgf/cm ² , lbf/in ²)
σ_{Ex}	=	elastic buckling stress, N/cm ² (kgf/cm ² , lbf/in ²)
	=	$0.6Et/D$
D	=	outer diameter, cm (in.)
t	=	thickness, cm (in.)

For tubular members with $D/t > E/(4.5\sigma_0)$, the local buckling stress is to be determined from 4/3.3.

9.3 Tubular Members Subjected to Bending Moment

Critical bending strength of tubular members with $D/t \leq E/(4.5\sigma_0)$ subjected to bending moment may be obtained from the following equation:

$$\sigma_{CB} = \begin{cases} (SM_p / SM_e) \sigma_0 & \text{for } \sigma_0 D / (Et) \leq 0.02 \\ [1.038 - 1.90 \sigma_0 D / (Et)] (SM_p / SM_e) \sigma_0 & \text{for } 0.02 < \sigma_0 D / (Et) \leq 0.10 \\ [0.921 - 0.73 \sigma_0 D / (Et)] (SM_p / SM_e) \sigma_0 & \text{for } \sigma_0 D / (Et) > 0.10 \end{cases}$$

where

SM_e	=	elastic section modulus, cm ³ (in ³)
	=	$(\pi/64)[D^4 - (D - 2t)^4]/(D/2)$
SM_p	=	plastic section modulus, cm ³ (in ³)
	=	$(1/6)[D^3 - (D - 2t)^3]$
D	=	outer diameter, cm (in.)

- t = thickness, cm (in.)
 E = modulus of elasticity, 2.06×10^7 N/cm² (2.1×10^6 kgf/cm², 30×10^6 lbf/in²) for steel
 σ_0 = specified minimum yield point

For tubular members with $D/t > E/(4.5\sigma_0)$, the local buckling stress is to be determined from 4/3.3.

9.5 Tubular Members Subjected to Hydrostatic Pressure

Tubular members with $D/t \leq E/(4.5\sigma_0)$ subjected to external pressure are to satisfy the following equation:

$$\sigma_\theta / \eta_\theta \sigma_{C\theta} \leq 1$$

where

- σ_θ = hoop stress due to hydrostatic pressure
 = $qD/(2t)$
 q = external pressure
 $\sigma_{C\theta}$ = critical hoop buckling strength, N/cm² (kgf/cm², lbf/in²)
 = $\Phi \sigma_{B\theta}$
 Φ = plasticity reduction factor
 = 1 for $\Delta \leq 0.55$
 = $\frac{0.45}{\Delta} + 0.18$ for $0.55 < \Delta \leq 1.6$
 = $\frac{1.31}{1 + 1.15\Delta}$ for $1.6 < \Delta < 6.25$
 = $1/\Delta$ for $\Delta \geq 6.25$
 Δ = $\sigma_{E\theta} / \sigma_0$
 $\sigma_{E\theta}$ = elastic hoop buckling stress
 = $2C_\theta Et/D$
 C_θ = buckling coefficient
 = $0.44t/D$ for $\mu \geq 1.6D/t$
 = $0.44t/D + 0.21(D/t)^3/\mu^4$ for $0.825D/t \leq \mu < 1.6D/t$
 = $0.737/(\mu - 0.579)$ for $1.5 \leq \mu < 0.825D/t$
 = 0.80 for $\mu < 1.5$
 μ = geometric parameter
 = $\ell / D\sqrt{2D/t}$
 ℓ = length of tubular member between stiffening rings, diaphragms or end connections
 D = outer diameter
 t = thickness
 E = modulus of elasticity, 2.06×10^7 N/cm² (2.1×10^6 kgf/cm², 30×10^6 lbf/in²) for steel
 σ_0 = specified minimum yield point
 η_θ = maximum allowable strength utilization factor for local buckling in the presence of hydrostatic pressure, as defined in Subsection 1/11 and 2/1.9

For tubular members with $D/t > E/(4.5\sigma_0)$, the state limit in 4/3.3 is to be applied.

9.7 Plate Elements Subjected to Compression and Bending Moment

The critical local buckling of a member with rolled or fabricated plate section may be taken as the smallest local buckling stress of the plate elements comprising the section. The local buckling stress of an element is to be obtained from the following equation with respect to uniaxial compression and in-plane bending moment:

$$\sigma_{Cx} = \begin{cases} \sigma_{Ex} & \text{if } \sigma_{Ex} \leq P_r \sigma_0 \\ \sigma_0 \left[1 - P_r (1 - P_r) \frac{\sigma_0}{\sigma_{Ex}} \right] & \text{if } \sigma_{Ex} > P_r \sigma_0 \end{cases}$$

where

- P_r = proportional linear elastic limit of the structure, which may be taken as 0.6 for steel
 σ_0 = specified minimum yield point, N/cm² (kgf/cm², lbf/in²)
 σ_{Ex} = elastic buckling stress, N/cm² (kgf/cm², lbf/in²)
 $= k_s \frac{\pi^2 E}{12(1-\nu^2)} \left(\frac{t}{s} \right)^2$
 E = modulus of elasticity, 2.06×10^7 N/cm² (2.1×10^6 kgf/cm², 30×10^6 lbf/in²) for steel
 ν = Poisson's ratio, 0.3 for steel
 s = depth of unsupported plate element
 t = thickness of plate element
 k_s = buckling coefficient, as follows:

- i) For a plate element with all four edges simply supported, the buckling coefficient is to be obtained from following equation:

$$k_s = \begin{cases} \frac{8.4}{\kappa + 1.1} & \text{for } 0 \leq \kappa \leq 1 \\ 7.6 - 6.4\kappa + 10\kappa^2 & \text{for } -1 \leq \kappa < 0 \end{cases}$$

where

- κ = ratio of edge stresses, as defined in Section 2, Figure 3
 $= \sigma_{amin} / \sigma_{amax}$

- ii) For a plate element with other boundary conditions, the buckling coefficient is obtained from Section 2, Table 3

FIGURE 3
Definition of Edge Stresses

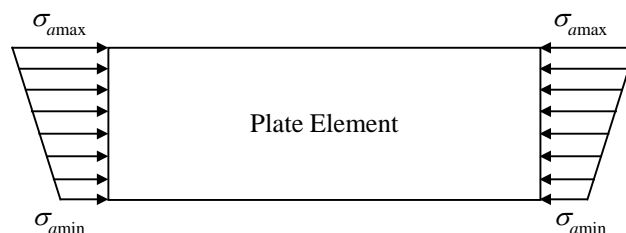
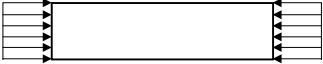
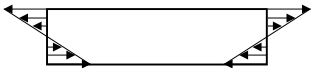
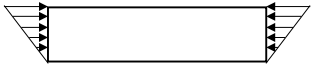

TABLE 3
Minimum Buckling Coefficients under Compression and Bending Moment, k_s *

Loading	Top Edge Free		Bottom Edge Free	
	Bottom Edge Simply Supported	Bottom Edge Fixed	Top Edge Simply Supported	Top Edge Fixed
$\sigma_{amin}/\sigma_{amax} = 1$ (Uniform compression) 	0.42	1.33	0.42	1.33
$\sigma_{amin}/\sigma_{amax} = -1$ (Pure Bending) 	—	—	0.85	2.15
$\sigma_{amin}/\sigma_{amax} = 0$ 	0.57	1.61	1.70	5.93

* Note: k_s for intermediate value of $\sigma_{amin}/\sigma_{amax}$ may be obtained by linear interpolation.



SECTION 3 Plates, Stiffened Panels and Corrugated Panels

1 General

The formulations provided in this Section are to be used to assess the Buckling and Ultimate Strength Limits of plates, stiffened panels and corrugated panels. Two State Limits for Buckling and Ultimate Strength are normally considered in structural design. The former is based on buckling and the latter is related to collapse.

The criteria provided in this Section apply to Offshore Structures, SPMs, SEDUs, CSDUs and FPIs of the TLP and SPAR types, and it is not in the scope of this Guide to use the criteria with ship-type FPIs. In this latter case, see [Section 5A-3-4](#) of the *FPI Rules*.

The design criteria apply also to stiffened panels for which the moment of inertia for the transverse girders is greater than the moment of inertia of the longitudinal stiffeners. It is not in the scope of this Guide to use the criteria for orthotropically stiffened plate panels.

Alternatively, the buckling and ultimate strength of plates, stiffened panels or corrugated panels may be determined based on either appropriate, well-documented experimental data or on a calibrated analytical approach. When a detailed analysis is not available, the equations provided in this section shall be used to assess the buckling strength.

1.1 Geometry of Plate, Stiffened Panel and Corrugated Panels

Flat rectangular plates and stiffened panels are depicted in Section 3, Figure 1. Stiffeners in the stiffened panels are usually installed equally spaced, parallel or perpendicular to panel edges in the direction of dominant load and are supported by heavier and more widely-spaced ‘deep supporting members’ (i.e., girders). The given criteria apply to a variety of stiffener profiles, such as flat-bar, built up T-profiles, built up inverted angle profiles and symmetric and non-symmetric bulb profiles. The section dimensions of a stiffener are defined in Section 3, Figure 2. The stiffeners may have strength properties different from those of the plate.

Corrugated panels, as depicted in Section 3, Figure 3, are self-stiffened and are usually corrugated in one direction, supported by stools at the two ends across the corrugation direction. They may act as watertight bulkheads or, when connected with fasteners, they are employed as corrugated shear diaphragms. The dimensions of corrugated panels are defined in Section 3, Figure 4. The buckling strength criteria for corrugated panels given in Subsection 3/11 are applicable to corrugated panels with corrugation angle, ϕ , between 57 and 90 degrees.

FIGURE 1
Typical Stiffened Panel

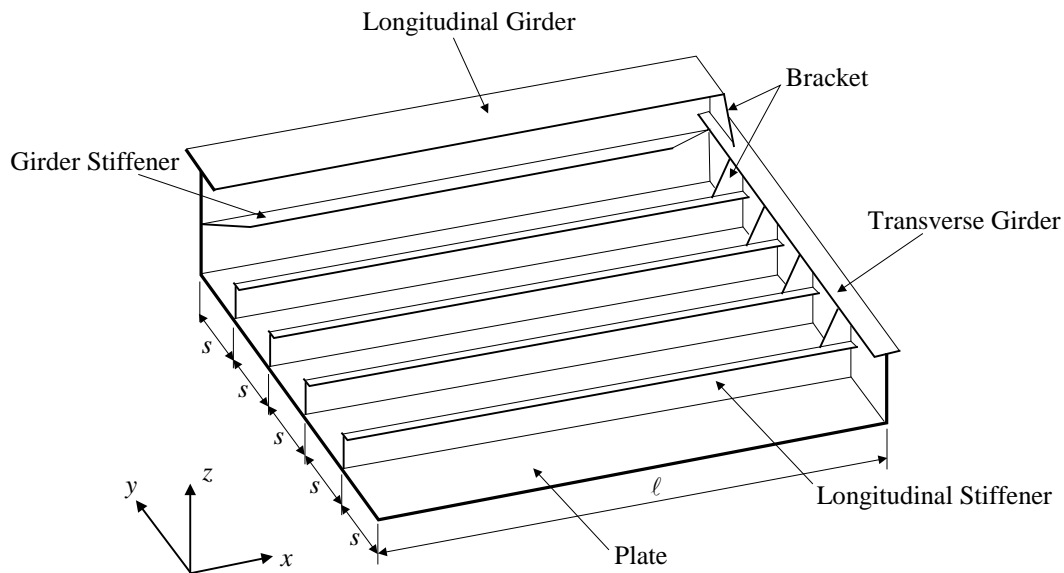

FIGURE 2
Sectional Dimensions of a Stiffened Panel

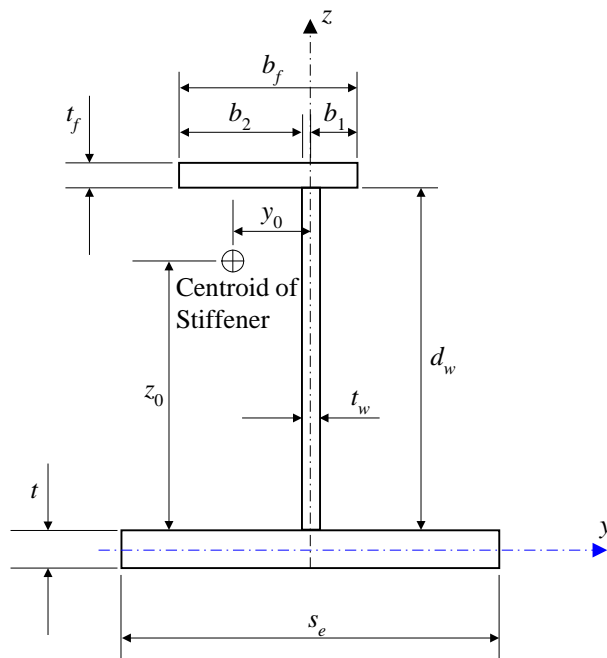

FIGURE 3
Typical Corrugated Panel

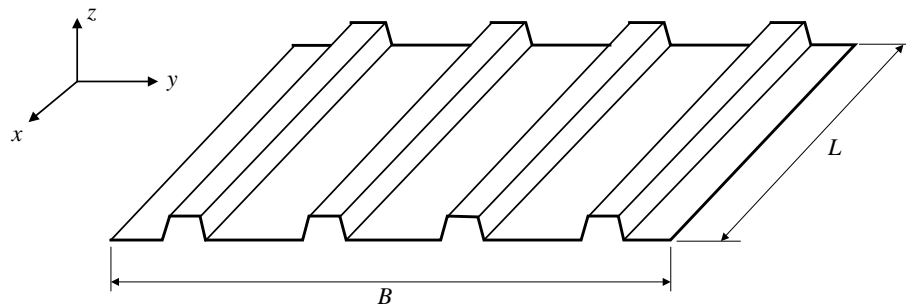
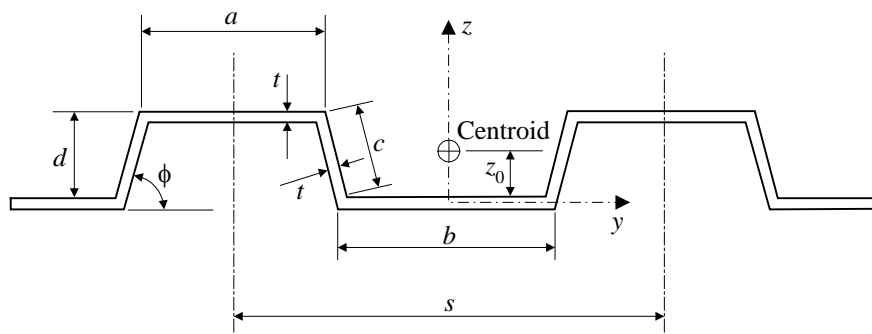

FIGURE 4
Sectional Dimensions of a Corrugated Panel



1.3 Load Application

The plate and stiffened panel criteria account for the following load and load effects. The symbols for each of these loads are shown in Section 3, Figure 5.

- Uniform in-plane compression, σ_{ax} , σ_{ay} *
- In-plane bending, σ_{bx} , σ_{by}
- Edge shear, τ
- Lateral loads, q
- Combinations of the above

* Note: If uniform stress σ_{ax} or σ_{ay} is tensile rather than compressive, it may be set equal to zero.

FIGURE 5
Primary Loads and Load Effects on Plate and Stiffened Panel

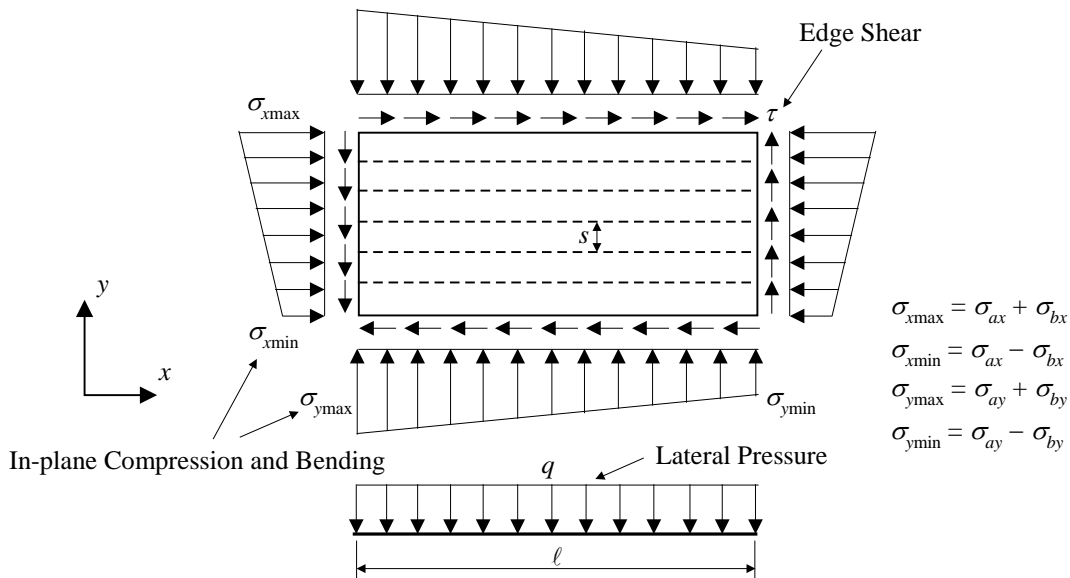

1.5 Buckling Control Concepts (1 February 2012)

The failure of plates and stiffened panels can be sorted into three levels, namely, the plate level, the stiffened panel level and the entire grillage level, which are depicted in Section 3, Figure 6. An offshore structure is to be designed in such a way that the buckling and ultimate strength of each level is greater than its preceding level (i.e., a well designed structure does not collapse when a plate fails as long as the stiffeners can resist the extra load they experience from the plate failure). Even if the stiffeners collapse, the structure may not fail immediately as long as the girders can support the extra load shed from the stiffeners.

The buckling strength criteria for plates and stiffened panels are based on the following assumptions and limits with respect to buckling control in the design of stiffened panels, which are in compliance with ABS recommended practices.

- The buckling strength of each stiffener is generally greater than that of the plate panel it supports.
- Stiffeners with their associated effective plating are to have moments of inertia not less than i_0 , given in 3/9.1. **If not satisfied, the overall buckling of stiffened panel is to be assessed, as specified in 3/5.7.**
- The deep supporting members (i.e., girders) with their associated effective plating are to have moments of inertia not less than I_s , given in 3/9.5. **If not satisfied, the overall buckling of stiffened panel is also necessary, as given in 3/5.7.** In addition, tripping (e.g., torsional/flexural instability) is to be prevented if tripping brackets are provided, as specified in 3/7.7.
- Faceplates and flanges of girders and stiffeners are proportioned such that local instability is prevented (see 3/9.7).
- Webs of girders and stiffeners are proportioned such that local instability is prevented (see 3/9.9).

For plates and stiffened panels that do not satisfy these limits, a detailed analysis of buckling strength using an acceptable method should be submitted for review.

FIGURE 6
Failure Modes ('Levels') of Stiffened Panel

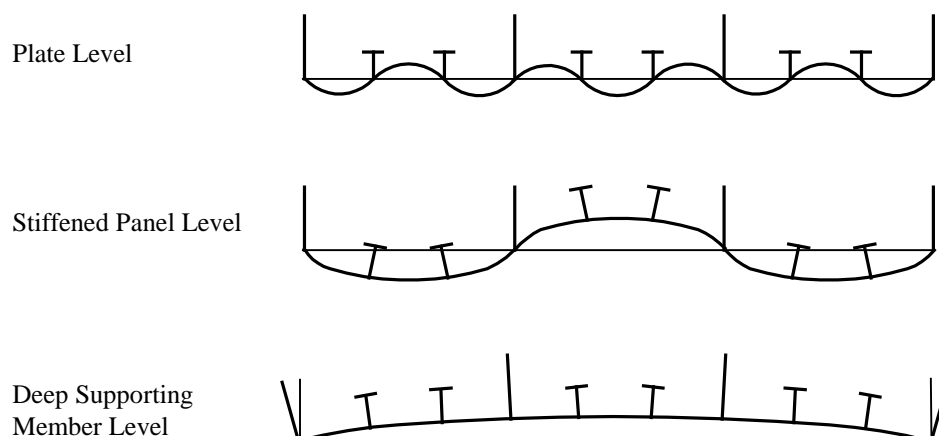

Section 3, Figure 6 illustrates the collapse shape for each level of failure mode. From a reliability point of view, no individual collapse mode can be 100 percent prevented. Therefore, the buckling control concept used in this Subsection is that the buckling and ultimate strength of each level is greater than its preceding level in order to avoid the collapse of the entire structure.

The failure ('levels') modes of a corrugated panel can be categorized as the face/web plate buckling level, the unit corrugation buckling level and the entire corrugation buckling level. In contrast to stiffened panels, corrugated panels will collapse immediately upon reaching any one of these three buckling levels.

1.7 Adjustment Factor

For the maximum allowable strength utilization factors, η , defined in Subsection 1/11, the adjustment factor is to take the following value:

$$\psi = 1.0$$

3 Plate Panels

For rectangular plate panels between stiffeners, buckling is acceptable, provided that the ultimate strength given in 3/3.3 and 3/3.5 of the structure satisfies the specified criteria. Offshore practice demonstrates that only an ultimate strength check is required for plate panels. A buckling check of plate panels is necessary when establishing the attached plating width for stiffened panels. If the plating does not buckle, the full width is to be used. Otherwise, the effective width is to be applied if the plating buckles but does not fail.

3.1 Buckling State Limit

For the Buckling State Limit of plates subjected to in-plane and lateral pressure loads, the following strength criterion is to be satisfied:

$$\left(\frac{\sigma_{x \max}}{\eta \sigma_{Cx}} \right)^2 + \left(\frac{\sigma_{y \max}}{\eta \sigma_{Cy}} \right)^2 + \left(\frac{\tau}{\eta \tau_C} \right)^2 \leq 1$$

where

- $\sigma_{x \max}$ = maximum compressive stress in the longitudinal direction, N/cm² (kgf/cm², lbf/in²)
- $\sigma_{y \max}$ = maximum compressive stress in the transverse direction, N/cm² (kgf/cm², lbf/in²)
- τ = edge shear stress, N/cm² (kgf/cm², lbf/in²)

- σ_{Cx} = critical buckling stress for uniaxial compression in the longitudinal direction, N/cm² (kgf/cm², lbf/in²)
- σ_{Cy} = critical buckling stress for uniaxial compression in the transverse direction, N/cm² (kgf/cm², lbf/in²)
- τ_C = critical buckling stress for edge shear, N/cm² (kgf/cm², lbf/in²)
- η = maximum allowable strength utilization factor, as defined in Subsection 1/11 and 3/1.7

The critical buckling stresses are specified below.

3.1.1 Critical Buckling Stress for Edge Shear

The critical buckling stress for edge shear, τ_C , may be taken as:

$$\tau_C = \begin{cases} \tau_E & \text{for } \tau_E \leq P_r \tau_0 \\ \tau_0 \left[1 - P_r (1 - P_r) \frac{\tau_0}{\tau_E} \right] & \text{for } \tau_E > P_r \tau_0 \end{cases}$$

where

- P_r = proportional linear elastic limit of the structure, which may be taken as 0.6 for steel
- τ_0 = shear strength of plate, N/cm² (kgf/cm², lbf/in²)
- $$= \frac{\sigma_0}{\sqrt{3}}$$
- σ_0 = specified minimum yield point of plate, N/cm² (kgf/cm², lbf/in²)
- τ_E = elastic shear buckling stress, N/cm² (kgf/cm², lbf/in²)
- $$= k_s \frac{\pi^2 E}{12(1-\nu^2)} \left(\frac{t}{s} \right)^2$$
- k_s = boundary dependent constant
- $$= \left[4.0 \left(\frac{s}{\ell} \right)^2 + 5.34 \right] C_1$$
- E = modulus of elasticity, 2.06 × 10⁷ N/cm² (2.1 × 10⁶ kgf/cm², 30 × 10⁶ lbf/in²) for steel
- ν = Poisson's ratio, 0.3 for steel
- ℓ = length of long plate edge, cm (in.)
- s = length of short plate edge, cm (in.)
- t = thickness of plating, cm (in.)
- C_1 = 1.1 for plate panels between angles or tee stiffeners; 1.0 for plate panels between flat bars or bulb plates; 1.0 for plate elements, web plate of stiffeners and local plate of corrugated panels

3.1.2 Critical Buckling Stress for Uniaxial Compression and In-plane Bending

The critical buckling stress, σ_{Ci} ($i = x$ or y), for plates subjected to combined uniaxial compression and in-plane bending may be taken as:

$$\sigma_{Ci} = \begin{cases} \sigma_{Ei} & \text{for } \sigma_{Ei} \leq P_r \sigma_0 \\ \sigma_0 \left[1 - P_r (1 - P_r) \frac{\sigma_0}{\sigma_{Ei}} \right] & \text{for } \sigma_{Ei} > P_r \sigma_0 \end{cases}$$

where

P_r = proportional linear elastic limit of the structure, which may be taken as 0.6 for steel

σ_{Ei} = elastic buckling stress, N/cm² (kgf/cm², lbf/in²)

$$= k_s \frac{\pi^2 E}{12(1-\nu^2)} \left(\frac{t}{s} \right)^2$$

For loading applied along the short edge of the plating (long plate):

$$k_s = C_1 \begin{cases} \frac{8.4}{\kappa + 1.1} & \text{for } 0 \leq \kappa \leq 1 \\ 7.6 - 6.4\kappa + 10\kappa^2 & \text{for } -1 \leq \kappa < 0 \end{cases}$$

For loading applied along the long edge of the plating (wide plate):

$$k_s = C_2 \begin{cases} \left[1.0875 \cdot \left(1 + \frac{1}{\alpha^2} \right)^2 - 18 \frac{1}{\alpha^2} \right] \cdot (1 + \kappa) + 24 \frac{1}{\alpha^2} & \text{for } \kappa < \frac{1}{3} \text{ and } 1 \leq \alpha \leq 2 \\ \left[1.0875 \cdot \left(1 + \frac{1}{\alpha^2} \right)^2 - 9 \frac{1}{\alpha} \right] \cdot (1 + \kappa) + 12 \frac{1}{\alpha} & \text{for } \kappa < \frac{1}{3} \text{ and } \alpha > 2 \\ \left(1 + \frac{1}{\alpha^2} \right)^2 (1.675 - 0.675\kappa) & \text{for } \kappa \geq \frac{1}{3} \end{cases}$$

where

α = aspect ratio

$$= \ell/s$$

κ = ratio of edge stresses, as defined in Section 3, Figure 5*

$$= \sigma_{imin} / \sigma_{imax}$$

* Note: There are several cases in the calculation of ratio of edge stresses, κ :

- If uniform stress σ_{ai} ($i = x, y$) < 0 (tensile) and in-plane stress σ_{bi} ($i = x, y$) = 0, buckling check is not necessary, provided edge shear is zero;
- If uniform stress σ_{ai} ($i = x, y$) < 0 (tensile) and in-plane bending stress σ_{bi} ($i = x, y$) \neq 0, then $\sigma_{imax} = \sigma_{bi}$ and $\sigma_{imin} = -\sigma_{bi}$, so that $\kappa = -1$;
- If uniform stress σ_{ai} ($i = x, y$) > 0 (compressive) and in-plane bending stress σ_{bi} ($i = x, y$) = 0, $\sigma_{imax} = \sigma_{imin} = \sigma_i$, then $\kappa = 1$;
- If uniform stress σ_{ai} ($i = x, y$) > 0 (compressive) and in-plane bending stress σ_{bi} ($i = x, y$) \neq 0, $\sigma_{imax} = \sigma_{ai} + \sigma_{bi}$, $\sigma_{imin} = \sigma_{ai} - \sigma_{bi}$ then $-1 < \kappa < 1$.

σ_0 = specified minimum yield point of plate, N/cm² (kgf/cm², lbf/in²)

E	=	modulus of elasticity, 2.06×10^7 N/cm ² (2.1×10^6 kgf/cm ² , 30×10^6 lbf/in ²) for steel
ν	=	Poisson's ratio, 0.3 for steel
ℓ	=	length of long plate edge, cm (in.)
s	=	length of short plate edge, cm (in.)
t	=	thickness of plating, cm (in.)
C_1	=	1.1 for plate panels between angles or tee stiffeners; 1.0 for plate panels between flat bars or bulb plates; 1.0 for plate elements, web plate of stiffeners and local plate of corrugated panels
C_2	=	1.2 for plate panels between angles or tee stiffeners; 1.1 for plate panels between flat bars or bulb plates; 1.0 for plate elements and web plates

3.3 Ultimate Strength under Combined In-plane Stresses

The ultimate strength for a plate between stiffeners subjected to combined in-plane stresses is to satisfy the following equation:

$$\left(\frac{\sigma_{x\max}}{\eta\sigma_{Ux}}\right)^2 - \varphi\left(\frac{\sigma_{x\max}}{\eta\sigma_{Ux}}\right)\left(\frac{\sigma_{y\max}}{\eta\sigma_{Uy}}\right) + \left(\frac{\sigma_{y\max}}{\eta\sigma_{Uy}}\right)^2 + \left(\frac{\tau}{\eta\tau_U}\right)^2 \leq 1$$

where

$\sigma_{x\max}$ = maximum compressive stress in the longitudinal direction, N/cm² (kgf/cm², lbf/in²)

$\sigma_{y\max}$ = maximum compressive stress in the transverse direction, N/cm² (kgf/cm², lbf/in²)

τ = edge shear stress, N/cm² (kgf/cm², lbf/in²)

φ = coefficient to reflect interaction between longitudinal and transverse stresses (negative values are acceptable)

$$= 1.0 - \beta/2$$

σ_{Ux} = ultimate strength with respect to uniaxial stress in the longitudinal direction, N/cm² (kgf/cm², lbf/in²)

$$= C_x \sigma_0 \geq \sigma_{Cx}$$

$$C_x = \begin{cases} 2/\beta - 1/\beta^2 & \text{for } \beta > 1 \\ 1.0 & \text{for } \beta \leq 1 \end{cases}$$

σ_{Uy} = ultimate strength with respect to uniaxial stress in the transverse direction, N/cm² (kgf/cm², lbf/in²)

$$= C_y \sigma_0 \geq \sigma_{Cy}$$

$$C_y = C_x \cdot \frac{s}{\ell} + 0.1 \left(1 - \frac{s}{\ell}\right) \left(1 + 1/\beta^2\right)^2 \leq 1$$

τ_U = ultimate strength with respect to edge shear, N/cm² (kgf/cm², lbf/in²)

$$= \tau_C + 0.5(\sigma_0 - \sqrt{3}\tau_C) / (1 + \alpha + \alpha^2)^{1/2} \geq \tau_C$$

σ_{Cx} = critical buckling stress for uniaxial compression in the longitudinal direction, specified in 3/3.1.2, N/cm² (kgf/cm², lbf/in²)

σ_{Cy} = critical buckling stress for uniaxial compression in the transverse direction, specified in 3/3.1.2, N/cm² (kgf/cm², lbf/in²)

τ_C	=	critical buckling stress for edge shear, as specified in 3/3.1.1
β	=	slenderness ratio
	=	$\frac{s}{t} \sqrt{\frac{\sigma_0}{E}}$
E	=	modulus of elasticity, N/cm ² (kgf/cm ² , lbf/in ²)
ℓ	=	length of long plate edge, cm (in.)
s	=	length of short plate edge, cm (in.)
t	=	thickness of plating, cm (in.)
σ_0	=	yield point of plate, N/cm ² (kgf/cm ² , lbf/in ²)
η	=	maximum allowable strength utilization factor, as defined in Subsection 1/11 and 3/1.7.

β , s_e and ℓ_e are as defined in 3/3.3. σ_{Cx} , σ_{Cy} , σ_0 , τ_C and α are as defined in 3/3.1.

3.5 Uniform Lateral Pressure

In addition to the buckling/ultimate strength criteria in 3/3.1 through 3/3.3, the ultimate strength of a panel between stiffeners subjected to uniform lateral pressure alone or combined with in-plane stresses is to also satisfy the following equation:

$$q_u \leq \eta 4.0 \sigma_0 \left(\frac{t}{s} \right)^2 \left(1 + \frac{1}{\alpha^2} \right) \sqrt{1 - \left(\frac{\sigma_e}{\sigma_0} \right)^2}$$

where

t	=	plate thickness, cm (in.)
α	=	aspect ratio
	=	ℓ/s
ℓ	=	length of long plate edge, cm (in.)
s	=	length of short plate edge, cm (in.)
σ_0	=	specified minimum yield point of plate, N/cm ² (kgf/cm ² , lbf/in ²)
σ_e	=	equivalent stress according to von Mises, N/cm ² (kgf/cm ² , lbf/in ²)
	=	$\sqrt{\sigma_{x \max}^2 - \sigma_{x \max} \sigma_{y \max} + \sigma_{y \max}^2 + 3\tau^2}$
$\sigma_{x \max}$	=	maximum compressive stress in the longitudinal direction, N/cm ² (kgf/cm ² , lbf/in ²)
$\sigma_{y \max}$	=	maximum compressive stress in the transverse direction, N/cm ² (kgf/cm ² , lbf/in ²)
τ	=	edge shear
η	=	maximum allowable strength utilization factor, as defined in Subsection 1/11 and 3/1.7

5 Stiffened Panels

(1 February 2012) The failure modes of stiffened panels include beam-column buckling, torsion and flexural buckling of stiffeners, **local buckling of stiffener web and faceplate, and overall buckling of the entire stiffened panel**. The stiffened panel strength against these failure modes is to be checked with the criteria provided in 3/5.1 through 3/5.7. Buckling state limits for a stiffened panel are considered its ultimate state limits.

5.1 Beam-Column Buckling State Limit

The beam-column buckling state limit may be determined as follows:

$$\frac{\sigma_a}{\eta\sigma_{CA}(A_e/A)} + \frac{C_m\sigma_b}{\eta\sigma_0[1 - \sigma_a/(\eta\sigma_{E(C)})]} \leq 1$$

where

- σ_a = nominal calculated compressive stress, N/cm² (kgf/cm², lbf/in²)
- = P/A
- P = total compressive load on stiffener using full width of associated plating, N (kgf, lbf)
- σ_{CA} = critical buckling stress, N/cm² (kgf/cm², lbf/in²)
- = $\sigma_{E(C)}$ for $\sigma_{E(C)} \leq P_r\sigma_0$
- = $\sigma_0 \left[1 - P_r(1 - P_r) \frac{\sigma_0}{\sigma_{E(C)}} \right]$ for $\sigma_{E(C)} > P_r\sigma_0$
- P_r = proportional linear elastic limit of the structure, which may be taken as 0.6 for steel
- $\sigma_{E(C)}$ = Euler's buckling stress
- = $\frac{\pi^2 E r_e^2}{\ell^2}$
- A = total sectional area, cm² (in²)
- = $A_s + st$
- A_s = sectional area of the longitudinal, excluding the associated plating, cm² (in²)
- A_e = effective sectional area, cm² (in²)
- = $A_s + s_e t$
- s_e = effective width, cm (in.)
- = s when the buckling state limit of the associated plating from 3/3.1 is satisfied
- = $C_x C_y C_{xy} s$ when the buckling state limit of the associated plating from 3/3.1 is not satisfied
- C_x = $\begin{cases} 2/\beta - 1/\beta^2 & \text{for } \beta > 1 \\ 1.0 & \text{for } \beta \leq 1 \end{cases}$
- C_y = $0.5\phi \left(\frac{\sigma_{y\max}}{\sigma_{Uy}} \right) + \sqrt{1 - \left(1 - 0.25\phi^2 \right) \left(\frac{\sigma_{y\max}}{\sigma_{Uy}} \right)^2}$ *
- * Note: A limit for C_y is that the transverse loading should be less than the transverse ultimate strength of the plate panels. The buckling check for stiffeners is not to be performed until the attached plate panels satisfy the ultimate strength criteria.
- $\sigma_{y\max}$ = maximum compressive stress in the transverse direction, N/cm² (kgf/cm², lbf/in²)
- σ_{Uy} = ultimate strength with respect to uniaxial stress in the transverse direction, as specified in 3/3.3, N/cm² (kgf/cm², lbf/in²)

$$C_{xy} = \sqrt{1 - \left(\frac{\tau}{\tau_0}\right)^2}$$

$$\varphi = 1.0 - \beta/2$$

$$\beta = \frac{s}{t} \sqrt{\frac{\sigma_0}{E}}$$

$$r_e = \text{radius of gyration of area, } A_e, \text{ cm (in.)}$$

$$= \sqrt{\frac{I_e}{A_e}}$$

$$I_e = \text{moment of inertia of longitudinal or stiffener, accounting for the effective width, } s_e, \text{ cm}^4 \text{ (in}^4\text{)}$$

$$E = \text{modulus of elasticity, } 2.06 \times 10^7 \text{ N/cm}^2 \text{ (} 2.1 \times 10^6 \text{ kgf/cm}^2, 30 \times 10^6 \text{ lbf/in}^2\text{) for steel}$$

$$\sigma_0 = \text{specified minimum yield point of the longitudinal or stiffener under consideration. If there is a large difference between the yield points of a longitudinal or stiffener and the plating, the yield point resulting from the weighting of areas is to be used. N/cm}^2 \text{ (kgf/cm}^2, \text{ lbf/in}^2\text{)}$$

$$\sigma_b = \text{bending stress, N/cm}^2 \text{ (kgf/cm}^2, \text{ lbf/in}^2\text{)}$$

$$= M/SM_w$$

$$M = \text{maximum bending moment induced by lateral loads, N-cm (kgf-cm, lbf-in)}$$

$$= qs\ell^2/12$$

$$C_m = \text{moment adjustment coefficient, which may be taken as 0.75}$$

$$q = \text{lateral pressure for the region considered, N/cm}^2 \text{ (kgf/cm}^2, \text{ lbf/in}^2\text{)}$$

$$s = \text{spacing of the longitudinal, cm (in.)}$$

$$\ell = \text{unsupported span of the longitudinal or stiffener, cm (in.), as defined in Section 3, Figure 7}$$

$$SM_w = \text{effective section modulus of the longitudinal at flange, accounting for the effective breadth, } s_w, \text{ cm}^3 \text{ (in}^3\text{)}$$

$$s_w = \text{effective breadth, as specified in Section 3, Figure 8, cm (in.)}$$

$$\eta = \text{maximum allowable strength utilization factor, as defined in Subsection 1/11 and 3/1.7}$$

FIGURE 7
Unsupported Span of Longitudinal

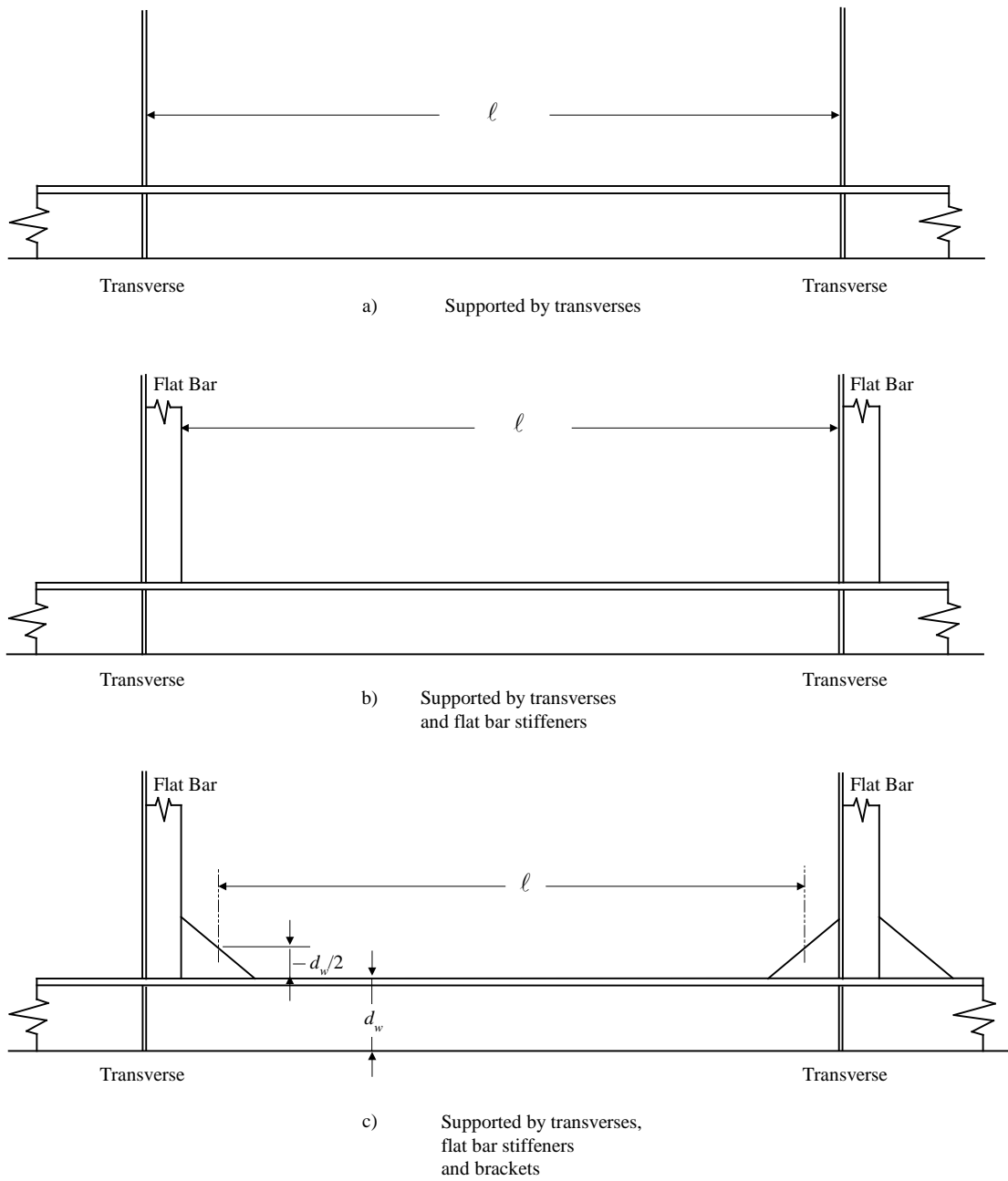
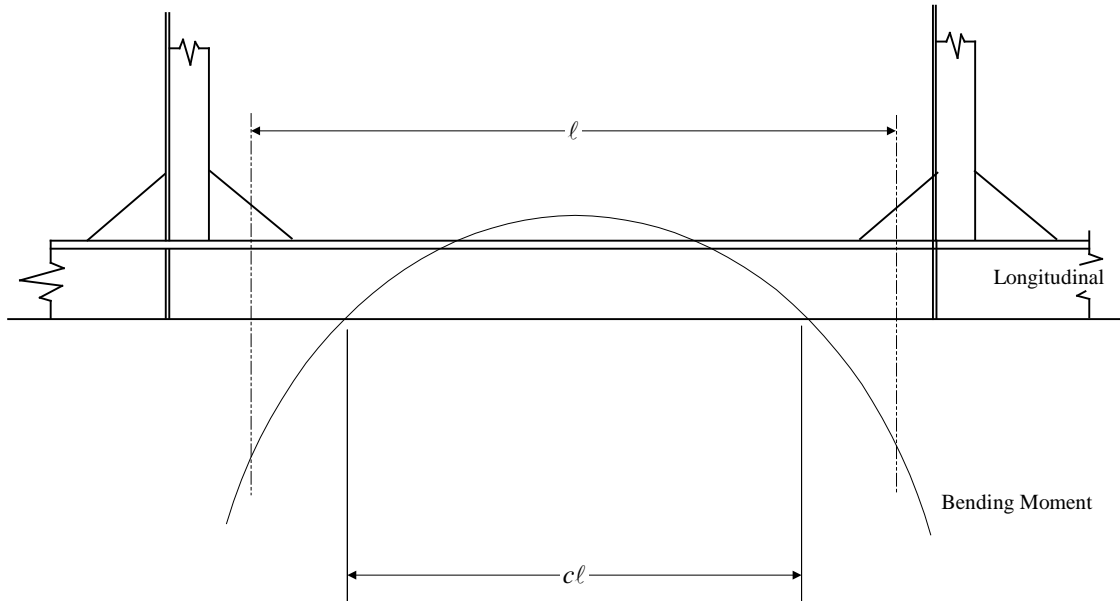

FIGURE 8
Effective Breadth of Plating s_w



$c\ell/s$	1.5	2	2.5	3	3.5	4	4.5 and greater
s_w/s	0.58	0.73	0.83	0.90	0.95	0.98	1.0

5.3 Flexural-Torsional Buckling State Limit

In general, the flexural-torsional buckling state limit of stiffeners or longitudinals is to satisfy the ultimate state limit given below:

$$\frac{\sigma_a}{\eta\sigma_{CT}} \leq 1$$

where

σ_a = nominal axial compressive stress of stiffener and its associated plating, N/cm² (kgf/cm², lbf/in²)

σ_{CT} = critical torsional/flexural buckling stress with respect to axial compression of a stiffener, including its associated plating, which may be obtained from the following equations:

$$= \begin{cases} \sigma_{ET} & \text{if } \sigma_{ET} \leq P_r \sigma_0 \\ \sigma_0 \left[1 - P_r (1 - P_r) \frac{\sigma_0}{\sigma_{ET}} \right] & \text{if } \sigma_{ET} > P_r \sigma_0 \end{cases}$$

P_r = proportional linear elastic limit of the structure, which may be taken as 0.6 for steel

σ_{ET} = elastic flexural-torsional-buckling stress with respect to the axial compression of a stiffener, including its associated plating, N/cm² (kgf/cm², lbf/in²)

$$= \frac{\frac{K}{2.6} + \left(\frac{n\pi}{\ell}\right)^2 \Gamma + \frac{C_0}{E} \left(\frac{\ell}{n\pi}\right)^2}{I_0 + \frac{C_0}{\sigma_{cL}} \left(\frac{\ell}{n\pi}\right)^2} E$$

- K = St. Venant torsion constant for the stiffener cross section, excluding the associated plating, cm^4 (in^4)

$$= \frac{b_f t_f^3 + d_w t_w^3}{3}$$
- I_0 = polar moment of inertia of the stiffener, excluding the associated plating (considered at the intersection of the web and plate), cm^4 (in^4)

$$= I_y + m I_z + A_s (y_0^2 + z_0^2)$$
- I_y, I_z = moment of inertia of the stiffener about the y - and z -axis, respectively, through the centroid of the longitudinal, excluding the plating (x -axis perpendicular to the y - z plane shown in Section 3, Figure 2), cm^4 (in^4)
- m =
$$1.0 - u \left(0.7 - 0.1 \frac{d_w}{b_f} \right)$$
- u = $1 - 2 \frac{b_1}{b_f}$, unsymmetrical factor
- y_0 = horizontal distance between centroid of stiffener, A_s , and web plate centerline (see Section 3, Figure 2), cm (in.)
- z_0 = vertical distance between centroid of stiffener, A_s , and its toe (see Section 3, Figure 2), cm (in.)
- d_w = depth of the web, cm (in.)
- t_w = thickness of the web, cm (in.)
- b_f = total width of the flange/face plate, cm (in.)
- b_1 = smaller outstand dimension of flange/face plate with respect to web's centerline, cm (in.)
- t_f = thickness of the flange/face, cm (in.)
- C_0 =
$$\frac{E t^3}{3s}$$
- Γ \cong warping constant, cm^6 (in^6)

$$\cong m I_{xf} d_w^2 + \frac{d_w^3 t_w^3}{36}$$
- I_{xf} =
$$\frac{t_f b_f^3}{12} \left(1.0 + 3.0 \frac{u^2 d_w t_w}{A_s} \right), \text{cm}^4 (\text{in}^4)$$
- σ_{cL} = critical buckling stress for associated plating corresponding to n -half waves, N/cm^2 (kgf/cm^2 , lbf/in^2)

$$= \frac{\pi^2 E \left(\frac{n}{\alpha} + \frac{\alpha}{n} \right)^2 \left(\frac{t}{s} \right)^2}{12(1 - \nu^2)}$$
- α = $\frac{\ell}{s}$
- n = number of half-waves that yield the smallest σ_{ET}

E	=	modulus of elasticity, 2.06×10^7 N/cm ² (2.1×10^6 kgf/cm ² , 30×10^6 lbf/in ²) for steel
ν	=	Poisson's ratio, 0.3 for steel
σ_0	=	specified minimum yield point of the material, N/cm ² (kgf/cm ² , lbf/in ²)
s	=	spacing of longitudinal/stiffeners, cm (in.)
A_s	=	sectional area of the longitudinal or stiffener, excluding the associated plating, cm ² (in ²)
t	=	thickness of the plating, cm (in.)
ℓ	=	unsupported span of the longitudinal or stiffener, cm (in.)
η	=	maximum allowable strength utilization factor, as defined in Subsection 1/11 and 3/1.7

5.5 Local Buckling of Web, Flange and Face Plate

The local buckling of stiffeners is to be assessed if the proportions of stiffeners specified in Subsection 3/9 are not satisfied.

5.5.1 Web

Critical buckling stress can be obtained from 3/3.1 by replacing s with the web depth and ℓ with the unsupported span, and taking:

$$k_s = 4C_s$$

where

C_s	=	1.0	for angle or tee bar
	=	0.33	for bulb plates
	=	0.11	for flat bar

5.5.2 Flange and Face Plate

Critical buckling stress can be obtained from 3/3.1 by replacing s with the larger outstanding dimension of flange, b_2 (see Section 3, Figure 2), and ℓ with the unsupported span, and taking:

$$k_s = 0.44$$

5.7 Overall Buckling State Limit (1 November 2011)

The overall buckling strength of the entire stiffened panels is to satisfy the following equation with respect to the biaxial compression:

$$\left(\frac{\sigma_x}{\eta\sigma_{Gx}} \right)^2 + \left(\frac{\sigma_y}{\eta\sigma_{Gy}} \right)^2 \leq 1$$

where

σ_x	=	calculated average compressive stress in the longitudinal direction, in N/cm ² (kgf/cm ² , lbf/in ²)
σ_y	=	calculated average compressive stress in the transverse direction, in N/cm ² (kgf/cm ² , lbf/in ²)
σ_{Gx}	=	critical buckling stress for uniaxial compression in the longitudinal direction, in N/cm ² (kgf/cm ² , lbf/in ²)
	=	$\begin{cases} \sigma_{Ex} & \text{if } \sigma_{Ex} \leq P_r \sigma_0 \\ \sigma_0 \left[1 - P_r (1 - P_r) \frac{\sigma_0}{\sigma_{Ex}} \right] & \text{if } \sigma_{Ex} > P_r \sigma_0 \end{cases}$

- σ_{Gy} = critical buckling stress for uniaxial compression in the transverse direction, in N/cm² (kgf/cm², lbf/in²)

$$= \begin{cases} \sigma_{Ey} & \text{if } \sigma_{Ey} \leq P_r \sigma_0 \\ \sigma_0 \left[1 - P_r (1 - P_r) \frac{\sigma_0}{\sigma_{Ey}} \right] & \text{if } \sigma_{Ey} > P_r \sigma_0 \end{cases}$$
- σ_{Ex} = elastic buckling stress in the longitudinal direction, in N/cm² (kgf/cm², lbf/in²)
 $= k_x \pi^2 (D_x D_y)^{1/2} / (t_x b^2)$
- σ_{Ey} = elastic buckling stress in the transverse direction, in N/cm² (kgf/cm², lbf/in²)
 $= k_y \pi^2 (D_x D_y)^{1/2} / (t_y \ell^2)$
- $k_x = 4$ for $\ell/b \geq 1$
 $= \frac{1}{\phi_x^2} + 2\rho + \phi_x^2$ for $\ell/b < 1$
- $k_y = 4$ for $b/\ell \geq 1$
 $= \frac{1}{\phi_y^2} + 2\rho + \phi_y^2$ for $b/\ell < 1$
- $\phi_x = (\ell/b)(D_y/D_x)^{1/4}$
 $\phi_y = (b/\ell)(D_x/D_y)^{1/4}$
- $D_x = EI_x / s_x (1 - \nu^2)$
 $D_y = EI_y / s_y (1 - \nu^2)$
 $= Et^3 / 12 (1 - \nu^2)$ if no stiffener in the transverse direction
- $\rho = [(I_{px} I_{py}) / (I_x I_y)]^{1/2}$
- t = thickness of the plate, in cm (in.)
- ℓ, b = length and width of stiffened panel, respectively, in cm (in.)
- t_x, t_y = equivalent thickness of the plate and stiffener in the longitudinal and transverse direction, respectively, in cm (in.)
 $= (s_x t + A_{sx}) / s_x$ or $(s_y t + A_{sy}) / s_y$
- s_x, s_y = spacing of stiffeners and girders, respectively, in cm (in.)
- A_{sx}, A_{sy} = sectional area of stiffeners and girders, excluding the associated plate, respectively, in cm (in.)
- I_{px}, I_{py} = moment of inertia of the effective plate alone about the neutral axis of the combined cross section, including stiffener and plate, in cm⁴ (in⁴)
- I_x, I_y = moment of inertia of the stiffener with effective plate in the longitudinal or transverse direction, respectively, in cm⁴ (in⁴). If no stiffener, the moment of inertia is calculated for the plate only.
- E = modulus of elasticity, 2.06×10^7 N/cm² (2.1×10^6 kgf/cm², 30×10^6 lbf/in²) for steel
- ν = Poisson's ratio, 0.3 for steel
- P_r = proportional linear elastic limit of the structure, which may be taken as 0.6 for steel
- σ_0 = specified minimum yield point of the material, in N/cm² (kgf/cm², lbf/in²)
- η = maximum allowable strength utilization factor, as defined in Subsection 1/11 and 3/1.7

7 Girders and Webs

In general, the stiffness of web stiffeners fitted to the depth of web plating is to be in compliance with 3/9.3. Web stiffeners that are oriented parallel to the face plate, and thus subject to axial compression, are to also satisfy 3/3.1, considering the combined effects of the compressive and bending stresses in the web. In this case, the unsupported span of these parallel stiffeners may be taken as the distance between tripping brackets, as applicable.

The buckling strength of the web plate between stiffeners and flange/face plate is to satisfy the limits specified in 3/3.1 through 3/3.5. When cutouts are present in the web plate, the effects of the cutouts on the reduction of the critical buckling stresses should be considered (See 3/7.9).

In general, girders are to be designed as stocky so that lateral buckling may be disregarded and torsional buckling also may be disregarded if tripping brackets are provided (See 3/7.7). If this is not the case, the girder is to be checked according to Subsection 3/5.

7.1 Web Plate

The buckling limit state for a web plate is considered as the ultimate state limit and is given in 3/3.1.

7.3 Face Plate and Flange

The breadth to thickness ratio of faceplate and flange is to satisfy the limits given in 3/9.7.

7.5 Large Brackets and Sloping Webs

The buckling strength is to satisfy the limits specified in 3/3.1 for the web plate.

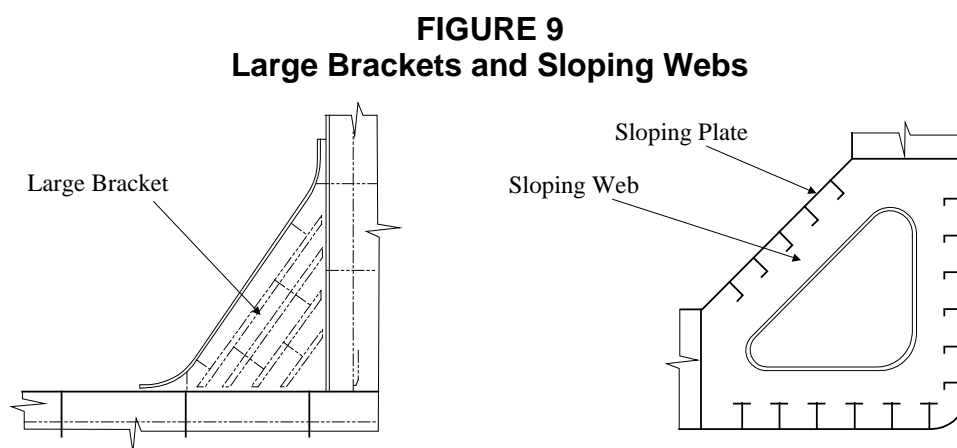

7.7 Tripping Brackets

To prevent tripping of deep girders and webs with wide flanges, tripping brackets are to be installed with spacing generally not greater than 3 meters (9.84 ft).

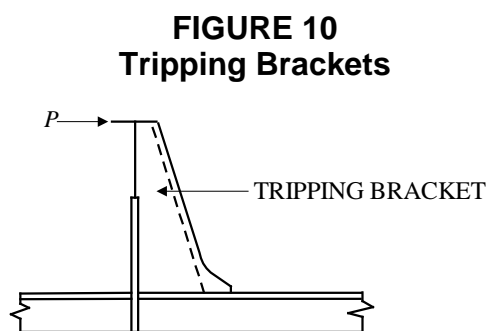

The design of tripping brackets may be based on the force, P , acting on the flange, as given by the following equation:

$$P = 0.02\sigma_{cl}(b_f t_f + \frac{1}{3}d_w b_w)$$

where

$$\begin{aligned} \sigma_{cl} &= \text{critical lateral buckling stress with respect to axial compression between tripping} \\ &\quad \text{brackets, N/cm}^2 \text{ (kgf/cm}^2 \text{, lbf/in}^2\text{)} \\ &= \sigma_{ce} && \text{for } \sigma_{ce} \leq P_r \sigma_0 \\ &= \sigma_0 [1 - P_r(1 - P_r) \sigma_0 / \sigma_{ce}] && \text{for } \sigma_{ce} > P_r \sigma_0 \\ \sigma_{ce} &= 0.6E[(b_f/t_f)(t_w/d_w)^3], \text{ N/cm}^2 \text{ (kgf/cm}^2 \text{, lbf/in}^2\text{)} \\ P_r &= \text{proportional linear elastic limit of the structure, which may be taken as 0.6 for steel} \\ E &= \text{modulus of elasticity, } 2.06 \times 10^7 \text{ N/cm}^2 \text{ (} 2.1 \times 10^6 \text{ kgf/cm}^2 \text{, } 30 \times 10^6 \text{ lbf/in}^2\text{) for steel} \\ \sigma_0 &= \text{specified minimum yield point of the material, N/cm}^2 \text{ (kgf/cm}^2 \text{, lbf/in}^2\text{)} \end{aligned}$$

b_f, t_f, d_w, t_w are defined in Section 3, Figure 2.

7.9 Effects of Cutouts

The depth of a cutout, in general, is to be not greater than $d_w/3$, and the calculated stresses in the area are to account for the local increase due to the cutout.

7.9.1 Reinforced by Stiffeners around Boundaries of Cut-outs

When reinforcement is made by installing straight stiffeners along boundaries of a cutout, the critical buckling stresses of the web plate between stiffeners with respect to compression, in-plane bending and shear may be obtained from 3/3.1.

7.9.2 Reinforced by Face Plates around Contour of Cut-outs

When reinforcement is made by adding face plates along the contour of a cut-out, the critical buckling stresses with respect to compression, bending and shear may be obtained from 3/3.1, without reduction, provided that the cross sectional area of the face plate is not less than $8t_w^2$, where t_w is the thickness of the web plate, and the depth of the cut-out is not greater than $d_w/3$, where d_w is the depth of the web.

7.9.3 No Reinforcement Provided

When reinforcement is not provided, the buckling strength of the web plate surrounding the cutout may be treated as a strip of plate with one edge free and the other edge simply supported.

$$k_s = 0.44$$

9 Stiffness and Proportions

To fully develop the intended buckling strength of assemblies of structural members and panels, supporting elements of plate panels and stiffeners are to satisfy the following requirements for stiffness and proportion in highly stressed regions.

9.1 Stiffness of Stiffeners

In the plane perpendicular to the plating, the moment of inertia of a stiffener, i_0 , with an effective breadth of plating, is not to be less than that given by the following equation:

$$i_0 = \frac{st^3}{12(1-\nu^2)}\gamma_0$$

where

$$\begin{aligned} \gamma_0 &= (2.6 + 4.0\delta)\alpha^2 + 12.4\alpha - 13.2\alpha^{1/2} \\ \delta &= A_s/(st) \\ \alpha &= \ell/s \\ s &= \text{spacing of longitudinal, cm (in.)} \\ t &= \text{thickness of plating supported by the longitudinal, cm (in.)} \\ \nu &= \text{Poisson's ratio, 0.3 for steel} \\ A_s &= \text{cross sectional area of the stiffener (excluding plating), cm}^2 \text{ (in}^2\text{)} \\ \ell &= \text{unsupported span of the stiffener, cm (in)} \end{aligned}$$

9.3 Stiffness of Web Stiffeners

The moment of inertia, I_e , of a web stiffener, with the effective breadth of plating not exceeding s or 0.33ℓ , whichever is less, is not to be less than the value obtained from the following equations:

$$\begin{aligned} I_e &= 0.17\ell t^3(\ell/s)^3 && \text{for } \ell/s \leq 2.0 \\ I_e &= 0.34\ell t^3(\ell/s)^2 && \text{for } \ell/s > 2.0 \end{aligned}$$

where

$$\begin{aligned} \ell &= \text{length of stiffener between effective supports, cm (in.)} \\ t &= \text{required thickness of web plating, cm (in.)} \\ s &= \text{spacing of stiffeners, cm (in.)} \end{aligned}$$

9.5 Stiffness of Supporting Girders

The moment of inertia of a supporting member is not to be less than that obtained from the following equation:

$$I_G/i_0 \geq 0.2(B/\ell)^3(B/s)$$

where

$$\begin{aligned} I_G &= \text{moment of inertia of the supporting girders, including the effective plating, cm}^4 \text{ (in}^4\text{)} \\ i_0 &= \text{moment of inertia of the stiffeners, including the effective plating, cm}^4 \text{ (in}^4\text{)} \\ B &= \text{unsupported span of the supporting girders, cm (in.)} \\ \ell &= \text{unsupported span of the stiffener, cm (in.), as defined in Section 3, Figure 7} \end{aligned}$$

9.7 Proportions of Flanges and Faceplates

The breadth to thickness ratio of flanges and faceplates of stiffeners and girders is to satisfy the limits given below.

$$b_2/t_f \leq 0.4(E/\sigma_0)^{1/2}$$

where

$$\begin{aligned} b_2 &= \text{larger outstand dimension of flange (See Section 3, Figure 2), cm (in.)} \\ t_f &= \text{thickness of flange/face plate, cm (in.)} \\ \sigma_0 &= \text{specified minimum yield point of plate, N/cm}^2 \text{ (kgf/cm}^2\text{, lbf/in}^2\text{)} \\ E &= \text{modulus of elasticity, } 2.06 \times 10^7 \text{ N/cm}^2 \text{ (} 2.1 \times 10^6 \text{ kgf/cm}^2\text{, } 30 \times 10^6 \text{ lbf/in}^2\text{) for steel} \end{aligned}$$

9.9 Proportions of Webs of Stiffeners

The depth to thickness ratio of webs of stiffeners is to satisfy the limits given below.

$$d_w/t_w \leq 1.5(E/\sigma_0)^{1/2} \quad \text{for angles and tee bars}$$

$$d_w/t_w \leq 0.85(E/\sigma_0)^{1/2} \quad \text{for bulb plates}$$

$$d_w/t_w \leq 0.4(E/\sigma_0)^{1/2} \quad \text{for flat bars}$$

where

$$\sigma_0 = \text{specified minimum yield point of plate, N/cm}^2 \text{ (kgf/cm}^2 \text{, lbf/in}^2\text{)}$$

$$E = \text{modulus of elasticity, } 2.06 \times 10^7 \text{ N/cm}^2 \text{ (} 2.1 \times 10^6 \text{ kgf/cm}^2 \text{, } 30 \times 10^6 \text{ lbf/in}^2\text{) for steel}$$

d_w and t_w are as defined in Section 3, Figure 2.

11 Corrugated Panels

This Subsection includes criteria for the buckling and ultimate strength for corrugated panels.

11.1 Local Plate Panels

The buckling strength of the flange and web plate panels is to satisfy the following state limit:

$$\left(\frac{\sigma_{x \max}}{\eta \sigma_{C_x}} \right)^2 + \left(\frac{\sigma_{y \max}}{\eta \sigma_{C_y}} \right)^2 + \left(\frac{\tau}{\eta \tau_C} \right)^2 \leq 1$$

where

$$\sigma_{x \max} = \text{maximum compressive stress in corrugation direction, N/cm}^2 \text{ (kgf/cm}^2 \text{, lbf/in}^2\text{)}$$

$$\sigma_{y \max} = \text{maximum compressive stress in transverse direction, N/cm}^2 \text{ (kgf/cm}^2 \text{, lbf/in}^2\text{)}$$

$$\tau = \text{in-plane shear stress, N/cm}^2 \text{ (kgf/cm}^2 \text{, lbf/in}^2\text{)}$$

$$\sigma_{C_x} = \text{critical buckling stress in corrugation direction from 3/3.1, N/cm}^2 \text{ (kgf/cm}^2 \text{, lbf/in}^2\text{)}$$

$$\sigma_{C_y} = \text{critical buckling stress in transverse direction from 3/3.1, N/cm}^2 \text{ (kgf/cm}^2 \text{, lbf/in}^2\text{)}$$

$$\tau_C = \text{critical buckling stress for edge shear from 3/3.1, N/cm}^2 \text{ (kgf/cm}^2 \text{, lbf/in}^2\text{)}$$

$$\eta = \text{maximum allowable strength utilization factor, as defined in Subsection 1/11 and 3/1.7}$$

11.3 Unit Corrugation

Any unit corrugation of the corrugated panel may be treated as a beam column and is to satisfy the following state limit:

$$\frac{\sigma_a}{\eta \sigma_{CA}} + \frac{C_m \sigma_b}{\eta \sigma_{CB} [1 - \sigma_a / (\eta \sigma_{E(C)})]} \leq 1$$

where

$$\sigma_a = \text{maximum compressive stress in the corrugation direction, N/cm}^2 \text{ (kgf/cm}^2 \text{, lbf/in}^2\text{)}$$

$$\sigma_b = \text{maximum bending stress along the length due to lateral pressure, N/cm}^2 \text{ (kgf/cm}^2 \text{, lbf/in}^2\text{)}$$

$$= M_b / SM$$

$$M_b = \text{maximum bending moment induced by lateral pressure, N-cm (kgf-cm, lbf-in)}$$

$$= \left(\frac{q_u + q_\ell}{2} \right) sL^2 / 12$$

- σ_{Ca} = critical buckling stress, N/cm² (kgf/cm², lbf/in²)
 = $\sigma_{E(C)}$ for $\sigma_{E(C)} \leq P_r \sigma_0$
 = $\sigma_0 \left[1 - P_r (1 - P_r) \frac{\sigma_0}{\sigma_{E(C)}} \right]$ for $\sigma_{E(C)} > P_r \sigma_0$
- $\sigma_{E(C)}$ = elastic buckling stress, N/cm² (kgf/cm², lbf/in²)
 = $\frac{\pi^2 E r^2}{L^2}$
- r = radius of gyration of area A , cm (in.)
 = $\sqrt{\frac{I_y}{A}}$
- E = modulus of elasticity, 2.06×10^7 N/cm² (2.1×10^6 kgf/cm², 30×10^6 lbf/in²) for steel
- σ_{CB} = critical bending buckling stress
 = $\sigma_{E(B)}$ for $\sigma_{E(B)} \leq P_r \sigma_0$
 = $\sigma_0 \left[1 - P_r (1 - P_r) \frac{\sigma_0}{\sigma_{E(B)}} \right]$ for $\sigma_{E(B)} > P_r \sigma_0$
- $\sigma_{E(B)}$ = elastic buckling stress of unit corrugation
 = $k_c \frac{E}{12(1 - \nu^2)} \left(\frac{t}{a} \right)^2$
- k_c = coefficient
 = $[7.65 - 0.26(c/a)^2]^2$
- C_m = bending moment factor determined by rational analysis, which may be taken as 1.5 for a panel whose ends are simply supported
- A, I_y = area and moment of inertia of unit corrugation, as specified in 3/13.3
- SM = sectional modulus of unit corrugation, as specified in 3/13.3, cm³ (in³)
- s = width of unit corrugation, as defined in Section 3, Figure 4 and specified in 3/13.3
- a, c = width of the compressed flange and web plating, respectively, as defined in Section 3, Figure 4
- t = thickness of the unit corrugation, cm (in.)
- L = length of corrugated panel, cm (in.)
- q_u, q_ℓ = lateral pressure at the two ends of the corrugation, N/cm² (kgf/cm², lbf/in²)
- P_r = proportional linear elastic limit of the structure, which may be taken as 0.6 for steel
- E = modulus of elasticity, 2.06×10^7 N/cm² (2.1×10^6 kgf/cm², 30×10^6 lbf/in²) for steel
- ν = Poisson's ratio, 0.3 for steel
- σ_0 = specified minimum yield point, N/cm² (kgf/cm², lbf/in²)
- η = maximum allowable strength utilization factor, as defined in Subsection 1/11 and 3/1.7

11.5 Overall Buckling

The overall buckling strength of the entire corrugated panels is to satisfy the following equation with respect to the biaxial compression and edge shear:

$$\left(\frac{\sigma_x}{\eta\sigma_{Gx}}\right)^2 + \left(\frac{\sigma_y}{\eta\sigma_{Gy}}\right)^2 + \left(\frac{\tau}{\eta\tau_G}\right)^2 \leq 1$$

where

σ_x = calculated average compressive stress in the corrugation direction, N/cm² (kgf/cm², lbf/in²)

σ_y = calculated average compressive stress in the transverse direction, N/cm² (kgf/cm², lbf/in²)

τ = in-plane shear stress, N/cm² (kgf/cm², lbf/in²)

σ_{Gx} = critical buckling stress for uniaxial compression in the corrugation direction, N/cm² (kgf/cm², lbf/in²)

$$= \begin{cases} \sigma_{Ex} & \text{if } \sigma_{Ex} \leq P_r \sigma_0 \\ \sigma_0 \left[1 - P_r (1 - P_r) \frac{\sigma_0}{\sigma_{Ex}} \right] & \text{if } \sigma_{Ex} > P_r \sigma_0 \end{cases}$$

σ_{Gy} = critical buckling stress for uniaxial compression in the transverse direction, N/cm² (kgf/cm², lbf/in²)

$$= \begin{cases} \sigma_{Ey} & \text{if } \sigma_{Ey} \leq P_r \sigma_0 \\ \sigma_0 \left[1 - P_r (1 - P_r) \frac{\sigma_0}{\sigma_{Ey}} \right] & \text{if } \sigma_{Ey} > P_r \sigma_0 \end{cases}$$

τ_G = critical buckling stress for shear stress, N/cm² (kgf/cm², lbf/in²)

$$= \begin{cases} \tau_E & \text{if } \tau_E \leq P_r \tau_0 \\ \tau_0 \left[1 - P_r (1 - P_r) \frac{\tau_0}{\tau_E} \right] & \text{if } \tau_E > P_r \tau_0 \end{cases}$$

σ_{Ex} = elastic buckling stress in the corrugation direction, N/cm² (kgf/cm², lbf/in²)

$$= k_x \pi^2 (D_x D_y)^{1/2} / (t_x B^2)$$

σ_{Ey} = elastic buckling stress in the transverse direction, N/cm² (kgf/cm², lbf/in²)

$$= k_y \pi^2 (D_x D_y)^{1/2} / (t L^2)$$

τ_E = elastic shear buckling stress, N/cm² (kgf/cm², lbf/in²)

$$= k_s \pi^2 D_x^{3/4} D_y^{1/4} / (t L^2)$$

k_x = 4 for $L/B \geq 0.5176(D_x/D_y)^{1/4}$

$$= \frac{1}{\phi_x^2} + \phi_x^2 \quad \text{for } L/B < 0.5176(D_x/D_y)^{1/4}$$

k_y = 4 for $B/L \geq 0.5176(D_y/D_x)^{1/4}$

$$= \frac{1}{\phi_y^2} + \phi_y^2 \quad \text{for } B/L < 0.5176(D_y/D_x)^{1/4}$$

k_s	=	3.65
L, B	=	length and width of corrugated panel
t_x	=	equivalent thickness of the corrugation in the corrugation direction, as specified in 3/13.3, cm (in.)
t	=	thickness of the corrugation, cm (in.)
ϕ_x	=	$(L/B)(D_y/D_x)^{1/4}$
ϕ_y	=	$(B/L)(D_x/D_y)^{1/4}$
D_x	=	EI_y/s
D_y	=	$\frac{Et^3}{12(1-\nu^2)} \frac{s}{a+b+2c}$
I_y	=	moment of inertia of a corrugation with spacing s
a, b, c	=	width of the flanges and web plating, respectively, as defined in Section 3, Figure 4, cm (in.)
s	=	width of the unit corrugation, as defined in Section 3, Figure 4, cm (in.)
E	=	modulus of elasticity, 2.06×10^7 N/cm ² (2.1×10^6 kgf/cm ² , 30×10^6 lbf/in ²) for steel
ν	=	Poisson's ratio, 0.3 for steel
σ_0	=	specified minimum yield point of the material, N/cm ² (kgf/cm ² , lbf/in ²)
η	=	maximum allowable strength utilization factor, as defined in Subsection 1/11 and 3/1.7

13 Geometric Properties

This Subsection includes the formulations for the geometric properties of stiffened panels and corrugated panels. The effective width, s_e , and effective breadth, s_w , can be obtained from 3/5.1 and Section 3, Figure 8, respectively.

13.1 Stiffened Panels

13.1.1 Beam-Column Buckling

$$\begin{aligned}
 b_f &= 0 && \text{for flat-bar} \\
 t_f &= 0 && \text{for flat-bar} \\
 b_1 &= 0.5 t_w && \text{for angle bar} \\
 A_s &= d_w t_w + b_f t_f \\
 A_e &= s_e t + A_s \\
 z_{ep} &= [0.5(t + d_w)d_w t_w + (0.5t + d_w + 0.5t_f)b_f t_f]/A_e \\
 I_e &= \frac{t_p^3 s_e}{12} + \frac{d_w^3 t_w}{12} + \frac{t_f^3 b_f}{12} + 0.25(t + d_w)^2 d_w t_w + b_f t_f (0.5t + d_w + 0.5t_f)^2 - A_e z_{ep}^2 \\
 r_e &= \sqrt{I_e / A_e} \\
 A_w &= s_w t + A_s \\
 z_{wp} &= [0.5(t + d_w)d_w t_w + (0.5t + d_w + 0.5t_f)b_f t_f]/A_w
 \end{aligned}$$

$$I_w = \frac{t_p^3 s_e}{12} + \frac{d_w^3 t_w}{12} + \frac{t_f^3 b_f}{12} + 0.25(t + d_w)^2 d_w t_w + b_f t_f (0.5t + d_w + t_f)^2 - A_w z_{wp}^2$$

$$SM_w = \frac{I_w}{(0.5t + d_w + t_f) - z_{wp}}$$

$t, b_f, b_1, t_f, d_w, t_w$ are defined in Section 3, Figure 2.

13.1.2 Torsional/Flexural Buckling

$$A_s = d_w t_w + b_f t_f$$

$$y_0 = (b_1 - 0.5b_f) b_f t_f / A_s$$

$$z_0 = [0.5d_w^2 t_w + (d_w + 0.5t_f) b_f t_f] / A_s$$

$$I_y = \frac{d_w^3 t_w}{12} + \frac{t_f^3 b_f}{12} + 0.25d_w^3 t_w + b_f t_f (d_w + 0.5t_f)^2 - A_s z_0^2$$

$$I_z = \frac{t_w^3 d_w}{12} + \frac{b_f^3 t_f}{12} + b_f t_f (b_1 - 0.5b_f)^2 - A_s z_0^2$$

$b_f, b_1, t_f, d_w, t_w, y_0$ and z_0 are defined in Section 3, Figure 2.

13.3 Corrugated Panels

The following formulations of geometrical properties are derived, provided that the section is thin-walled and the thickness is small.

$$s = a + b + 2c \cos \phi$$

$$t_x = (st + A_{sx}) / s$$

$$A = (a + b)t + 2ct$$

$$A_{sx} = 2ct \sin \phi$$

$$z_o = dt(a + c) / A$$

$$I_y = \frac{(a + b)t^3}{12} + ad^2 t + \frac{2}{3} cd^2 t - Az_o^2$$

$$SM = I_y / z_o \text{ or } I_y / (d - z_o), \text{ which is the less}$$

a, b, c, d, t, ϕ and z_o are defined in Section 3, Figure 4.

SECTION 4 Cylindrical Shells

1 General

This Section presents criteria for calculating the buckling limit state of ring- and/or stringer-stiffened cylindrical shells subjected to axial loading, bending moment, radial pressure or a combination of these loads. The buckling limit state of a stiffened cylindrical shell is to be determined based on the formulations provided below. Alternatively, either well-documented experimental data or a verified analytical approach may be employed.

1.1 Geometry of Cylindrical Shells

The criteria given below apply to ring- and/or stringer-stiffened cylindrical shells, as depicted in Section 4, Figure 1, where coordinates (x, r, θ) denote the longitudinal, radial and circumferential directions, respectively. Stiffeners in a given direction are to be equally spaced, parallel and perpendicular to panel edges, and have identical material and geometric properties. General types of stiffener profiles, such as flat bar, T-bar, angle and bulb plate, may be used. The dimensions and properties of a ring or stringer stiffener are described in Section 4, Figure 2. The material properties of the stiffeners may be different from those of the shell plating.

FIGURE 1
Ring and Stringer-stiffened Cylindrical Shell

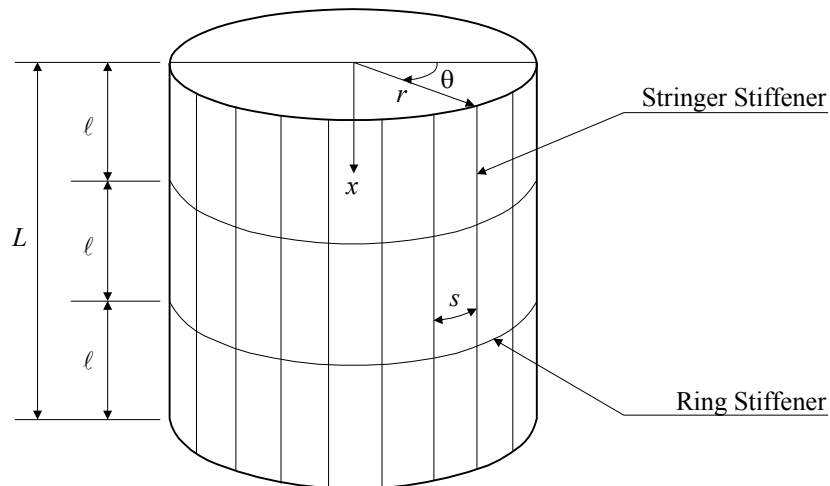

The formulations given for ring- and/or stringer-stiffened shells are applicable for offshore structures with the diameter to thickness ratio in the range of $E/(4.5\sigma_0)$ to 1000.

FIGURE 2
Dimensions of Stiffeners

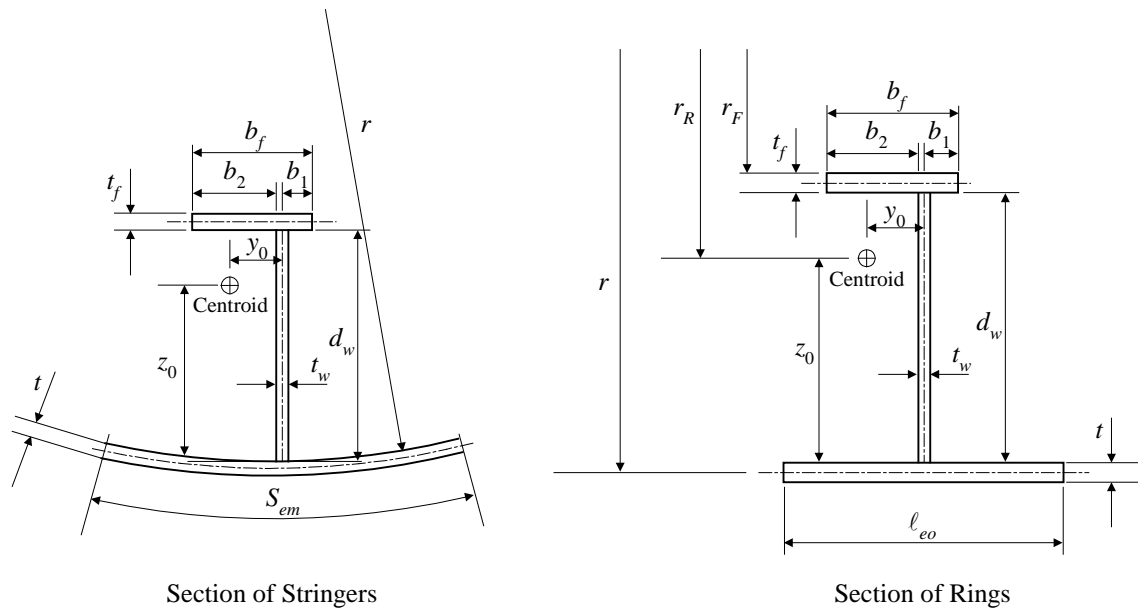

1.3 Load Application

This Section includes the buckling state limit criteria for the following loads and load effects.

- Uniform compression in the longitudinal direction, σ_a *
- Bending of the overall cylinder, σ_b
- External pressure, p
- Combinations of the above

* Note: If uniform stress, σ_a , is tensile rather than compressive, it may be set equal to zero.

1.5 Buckling Control Concepts

The probable buckling modes of ring- and/or stringer-stiffened cylindrical shells can be sorted as follows:

- Local shell or curved panel buckling (i.e., buckling of the shell between adjacent stiffeners). The stringers remain straight and the ring stiffeners remain round.
- Bay buckling (i.e., buckling of the shell plating together with the stringers, if present, between adjacent ring stiffeners). The ring stiffeners and the ends of the cylindrical shells remain round.
- General buckling, (i.e., buckling of one or more ring stiffeners together with the attached shell plus stringers, if present).
- Local stiffener buckling (i.e., torsional/flexural buckling of stiffeners, ring or stringer, or local buckling of the web and flange). The shell remains undeformed.
- Column buckling (i.e., buckling of cylindrical shell as a column).

The first three failure modes for ring and stringer-stiffened cylindrical shells are illustrated in Section 4, Figure 3.

FIGURE 3
Typical Buckling Modes of Ring and Stringer Cylindrical Shells

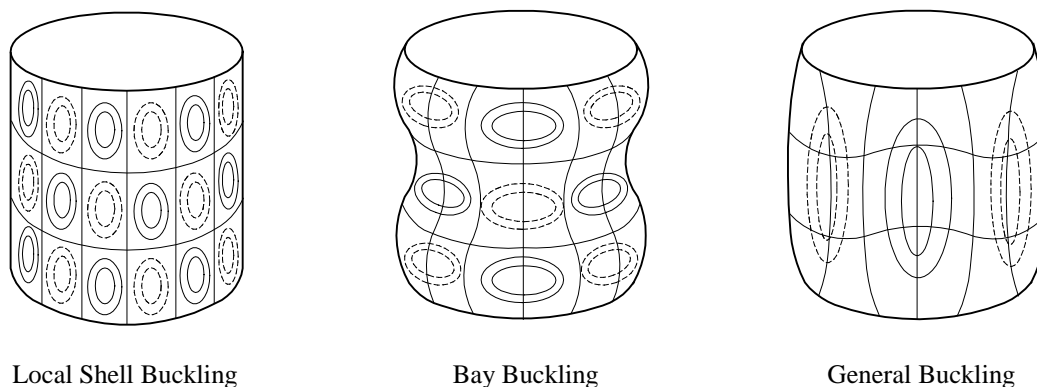

A stiffened cylindrical shell is to be designed such that a general buckling failure is preceded by bay instability, and local shell buckling precedes bay instability.

The buckling strength criteria presented below are based on the following assumptions and limitations:

- Ring stiffeners with their associated effective shell plating are to have moments of inertia not less than i_r , as given in 4/15.1.
- Stringer stiffeners with their associated effective shell plating are to have moments of inertia not less than i_s , as given in 4/15.3.
- Faceplates and flanges of stiffener are proportioned such that local instability is prevented, as given in 4/15.7.
- Webs of stiffeners are proportioned such that local instability is prevented, as given in 4/15.5.

For stiffened cylindrical shells that do not satisfy these assumptions, a detailed analysis of buckling strength using an acceptable method should be pursued.

1.7 Adjustment Factor

For the maximum allowable strength utilization factor, η , defined in Subsection 1/11, the adjustment factor is to take the following value:

For shell buckling: *

$$\begin{aligned} \psi &= 0.833 && \text{if } \sigma_{Cij} \leq 0.55\sigma_0 \\ &= 0.629 + 0.371\sigma_{Cij}/\sigma_0 && \text{if } \sigma_{Cij} > 0.55\sigma_0 \end{aligned}$$

where

σ_{Cij} = critical buckling stress of cylindrical shell, representing $\sigma_{C\&R}$, $\sigma_{C\&R}$, $\sigma_{C\&P}$, $\sigma_{C\&P}$, $\sigma_{C\&B}$ or $\sigma_{C\&B}$, which are specified in Subsections 4/3, 4/5 and 4/7, respectively, N/cm² (kgf/cm², lbf/in²)

σ_0 = specified minimum yield point, N/cm² (kgf/cm², lbf/in²)

* Note: The maximum allowable strength factor for shell buckling should be based on the critical buckling stress, which implies that it may be different for axial compression and external pressure in local shell or bay buckling. The smallest maximum allowable strength factor should be used in the corresponding buckling state limit.

For column buckling:

$$\begin{aligned} \psi &= 0.87 && \text{if } \sigma_{E(C)} \leq P_r \sigma_0 \\ &= 1 - 0.13 \sqrt{P_r \sigma_0 / \sigma_{E(C)}} && \text{if } \sigma_{E(C)} > P_r \sigma_0 \end{aligned}$$

where

$$\begin{aligned} \sigma_{E(C)} &= \text{Euler's buckling stress, as specified in Subsection 4/11, N/cm}^2 \text{ (kgf/cm}^2 \text{, lbf/in}^2\text{)} \\ P_r &= \text{proportional linear elastic limit of the structure, which may be taken as 0.6 for steel} \\ \sigma_0 &= \text{specified minimum yield point, N/cm}^2 \text{ (kgf/cm}^2 \text{, lbf/in}^2\text{)} \end{aligned}$$

For tripping of stringer stiffeners:

$$\psi = 1.0$$

3 Unstiffened or Ring-stiffened Cylinders

3.1 Bay Buckling Limit State

For the buckling limit state of unstiffened or ring-stiffened cylindrical shells between adjacent ring stiffeners subjected to axial compression, bending moment and external pressure, the following strength criterion is to be satisfied:

$$\left(\frac{\sigma_x}{\eta \sigma_{CxR}} \right)^2 - \phi_R \left(\frac{\sigma_x}{\eta \sigma_{CxR}} \right) \left(\frac{\sigma_\theta}{\eta \sigma_{C\theta R}} \right) + \left(\frac{\sigma_\theta}{\eta \sigma_{C\theta R}} \right)^2 \leq 1$$

where

$$\begin{aligned} \sigma_x &= \text{compressive stress in longitudinal direction from 4/13.1, N/cm}^2 \text{ (kgf/cm}^2 \text{, lbf/in}^2\text{)} \\ \sigma_\theta &= \text{compressive hoop stress from 4/13.3, N/cm}^2 \text{ (kgf/cm}^2 \text{, lbf/in}^2\text{)} \\ \sigma_{CxR} &= \text{critical buckling stress for axial compression or bending moment from 4/3.3, N/cm}^2 \text{ (kgf/cm}^2 \text{, lbf/in}^2\text{)} \\ \sigma_{C\theta R} &= \text{critical buckling stress for external pressure from 4/3.5, N/cm}^2 \text{ (kgf/cm}^2 \text{, lbf/in}^2\text{)} \\ \phi_R &= \text{coefficient to reflect interaction between longitudinal and hoop stresses (negative values are acceptable)} \\ &= \frac{\sigma_{CxR} + \sigma_{C\theta R}}{\sigma_0} - 1.0 \\ \sigma_0 &= \text{specified minimum yield point, N/cm}^2 \text{ (kgf/cm}^2 \text{, lbf/in}^2\text{)} \\ \eta &= \text{maximum allowable strength utilization factor of shell buckling, as specified in Subsection 1/11 and 4/1.7, for ring-stiffened cylindrical shells subjected to axial compression or external pressure, whichever is less.} \end{aligned}$$

3.3 Critical Buckling Stress for Axial Compression or Bending Moment

The critical buckling stress of unstiffened or ring-stiffened cylindrical shell subjected to axial compression or bending moment may be taken as:

$$\sigma_{CxR} = \begin{cases} \sigma_{ExR} & \text{for } \sigma_{ExR} \leq P_r \sigma_0 \\ \sigma_0 \left[1 - P_r (1 - P_r) \frac{\sigma_0}{\sigma_{ExR}} \right] & \text{for } \sigma_{ExR} > P_r \sigma_0 \end{cases}$$

where

- P_r = proportional linear elastic limit of the structure, which may be taken as 0.6 for steel
 σ_{ExR} = elastic compressive buckling stress for an imperfect cylindrical shell, N/cm² (kgf/cm², lbf/in²)
 σ_{CEXR} = classical compressive buckling stress for a perfect cylindrical shell, N/cm² (kgf/cm², lbf/in²)
 ρ_{xR} = nominal or lower bound knock-down factor to allow for shape imperfections
 C = length dependant coefficient
 z = Batdorf parameter
 ℓ = length between adjacent ring stiffeners (unsupported)
 r = mean radius of cylindrical shell, cm (in.)
 t = thickness of cylindrical shell, cm (in.)
 E = modulus of elasticity, 2.06 × 10⁷ N/cm² (2.1 × 10⁶ kgf/cm², 30 × 10⁶ lbf/in²) for steel
 ν = Poisson's ratio, 0.3 for steel
 σ_0 = specified minimum yield point, N/cm² (kgf/cm², lbf/in²)

3.5 Critical Buckling Stress for External Pressure

The critical buckling stress for an unstiffened or ring-stiffened cylindrical shell subjected to external pressure may be taken as:

$$\sigma_{COR} = \Phi \sigma_{EOR}$$

where

- Φ = plasticity reduction factor
 $\Phi = 1$ for $\Delta \leq 0.55$
 $\Phi = \frac{0.45}{\Delta} + 0.18$ for $0.55 < \Delta \leq 1.6$
 $\Phi = \frac{1.31}{1 + 1.15\Delta}$ for $1.6 < \Delta < 6.25$
 $\Phi = 1/\Delta$ for $\Delta \geq 6.25$

- Δ = $\sigma_{E\theta R} / \sigma_0$
 $\sigma_{E\theta R}$ = elastic hoop buckling stress for an imperfect cylindrical shell, N/cm² (kgf/cm², lbf/in²)
 = $\rho_{\theta R} \frac{q_{CE\theta R} (r + 0.5t)}{t} K_{\theta}$
 $\rho_{\theta R}$ = nominal or lower bound knock-down factor to allow for shape imperfections
 = 0.8
 K_{θ} = coefficient to account for the effect of ring stiffener, as determined from 4/13.3
 $q_{CE\theta R}$ = elastic buckling pressure, N/cm² (kgf/cm², lbf/in²)
 = $\begin{cases} \frac{1.27E}{A_L^{1.18} + 0.5} \left(\frac{t}{r}\right)^2 & \text{for } A_L \leq 2.5 \\ \frac{0.92E}{A_L} \left(\frac{t}{r}\right)^2 & \text{for } 2.5 < A_L \leq 0.208 \frac{r}{t} \\ 0.836C_p^{-1.061} E \left(\frac{t}{r}\right)^3 & \text{for } 0.208 \frac{r}{t} < A_L \leq 2.85 \frac{r}{t} \\ 0.275E \left(\frac{t}{r}\right)^3 & \text{for } 2.85 \frac{r}{t} < A_L \end{cases}$
 A_L = $\frac{\sqrt{z}}{(1-\nu^2)^{1/4}} - 1.17 + 1.068k$
 C_p = $A_L / (r/t)$
 k = 0 for lateral pressure
 = 0.5 for hydrostatic pressure
 z = Batdorf parameter
 = $\frac{\ell^2}{rt} \sqrt{1-\nu^2}$
 ℓ = length between adjacent ring stiffeners (unsupported)
 r = mean radius of cylindrical shell, cm (in.)
 t = thickness of cylindrical shell, cm (in.)
 E = modulus of elasticity, 2.06×10^7 N/cm² (2.1×10^6 kgf/cm², 30×10^6 lbf/in²) for steel
 ν = Poisson's ratio, 0.3 for steel
 σ_0 = specified minimum yield point, N/cm² (kgf/cm², lbf/in²)

3.7 General Buckling

The general buckling of a ring-stiffened cylindrical shell involves the collapse of one or more ring stiffeners together with the shell plating and is to be avoided due to its catastrophic consequences. The ring stiffeners are to be proportioned in accordance with [Subsection 4/15](#) to exclude the general buckling failure mode.

5 Curved Panels

Local curved panel buckling of ring and stringer-stiffened cylindrical shells will not necessarily lead to complete failure of the shell, as stresses can be redistributed to the remaining effective section associated with the stringer. However, knowledge of local buckling behavior is necessary in order to control local deflections, in accordance with serviceability requirements, and to determine the effective width to be associated with the stringer when determining buckling strength of the stringer-stiffened shells.

5.1 Buckling State Limit

The buckling state limit of curved panels between adjacent stiffeners can be defined by the following equation:

$$\left(\frac{\sigma_x}{\eta\sigma_{CxP}} \right)^2 - \varphi_P \left(\frac{\sigma_x}{\eta\sigma_{CxP}} \right) \left(\frac{\sigma_\theta}{\eta\sigma_{C\theta P}} \right) + \left(\frac{\sigma_\theta}{\eta\sigma_{C\theta P}} \right)^2 \leq 1$$

where

- σ_x = compressive stress in the longitudinal direction from 4/13.1, N/cm² (kgf/cm², lbf/in²)
- σ_θ = compressive hoop stress from 4/13.3, N/cm² (kgf/cm², lbf/in²)
- σ_{CxP} = critical buckling stress for axial compression or bending moment from 4/5.3, N/cm² (kgf/cm², lbf/in²)
- $\sigma_{C\theta P}$ = critical buckling stress for external pressure from 4/5.5, N/cm² (kgf/cm², lbf/in²)
- φ_P = coefficient to reflect interaction between longitudinal and hoop stresses (negative values are acceptable),

$$= \frac{0.4(\sigma_{CxP} + \sigma_{C\theta P})}{\sigma_0} - 0.8$$
- σ_0 = specified minimum yield point, N/cm² (kgf/cm², lbf/in²)
- η = maximum allowable strength utilization factor of shell buckling, as specified in Subsection 1/11 and 4/1.7 for curved panels in axial compression or external pressure, whichever is the lesser

5.3 Critical Buckling Stress for Axial Compression or Bending Moment

The critical buckling stress for curved panels bounded by adjacent pairs of ring and stringer stiffeners subjected to axial compression or bending moment may be taken as:

$$\sigma_{CxP} = \begin{cases} \sigma_{Exp} & \text{for } \sigma_{Exp} \leq P_r \sigma_0 \\ \sigma_0 \left[1 - P_r (1 - P_r) \frac{\sigma_0}{\sigma_{Exp}} \right] & \text{for } \sigma_{Exp} > P_r \sigma_0 \end{cases}$$

where

- P_r = proportional linear elastic limit of the structure, which may be taken as 0.6 for steel
- σ_{Exp} = elastic buckling stress for an imperfect curved panel, N/cm² (kgf/cm², lbf/in²)

$$= B_{xP} \rho_{xP} \sigma_{CEXP}$$
- σ_{CEXP} = classical buckling stress for a perfect curved panel between adjacent stringer stiffeners, N/cm² (kgf/cm², lbf/in²)

$$= K_{xP} \frac{\pi^2 E}{12(1 - \nu^2)} \left(\frac{t}{s} \right)^2$$

$$K_{xP} = 4 + \frac{3z_s^2}{\pi^4} \quad \text{for } z_s \leq 11.4$$

$$= 0.702z_s \quad \text{for } z_s > 11.4$$

ρ_{xP} = nominal or lower bound knock-down factor to allow for shape imperfections

$$= 1 - 0.019z_s^{1.25} + 0.0024z_s \left(1 - \frac{r}{300t}\right) \quad \text{for } z_s \leq 11.4$$

$$= 0.27 + \frac{1.5}{z_s} + \frac{27}{z_s^2} + 0.008\sqrt{z_s} \left(1 - \frac{r}{300t}\right) \quad \text{for } z_s > 11.4$$

B_{xP} = factor compensating for the lower bound nature of ρ_{xP}

$$= \begin{cases} 1.15 & \text{for } \lambda_n > 1 \\ 1 + 0.15\lambda_n & \text{for } \lambda_n \leq 1 \end{cases}$$

$$\lambda_n = \sqrt{\frac{\sigma_0}{\rho_{xP}\sigma_{CEXP}}}$$

$$z_s = \sqrt{1 - \nu^2} \frac{s^2}{rt}$$

s = spacing of stringer stiffeners, cm (in.)

r = mean radius of cylindrical shell, cm (in.)

t = thickness of cylindrical shell, cm (in.)

E = modulus of elasticity, 2.06×10^7 N/cm² (2.1×10^6 kgf/cm², 30×10^6 lbf/in²) for steel

ν = Poisson's ratio, 0.3 for steel

σ_0 = specified minimum yield point, N/cm² (kgf/cm², lbf/in²)

5.5 Critical Buckling Stress under External Pressure

The critical buckling stress for curved panels bounded by adjacent pairs of ring and stringer stiffeners subjected to external pressure may be taken as:

$$\sigma_{C\theta P} = \Phi \sigma_{E\theta P}$$

where

$$\Phi = \begin{cases} \text{plasticity reduction factor} \\ 1 & \text{for } \Delta \leq 0.55 \\ \frac{0.45}{\Delta} + 0.18 & \text{for } 0.55 < \Delta \leq 1.6 \\ \frac{1.31}{1 + 1.15\Delta} & \text{for } 1.6 < \Delta < 6.25 \\ 1/\Delta & \text{for } \Delta \geq 6.25 \end{cases}$$

$$\Delta = \sigma_{E\theta P} / \sigma_0$$

$$\sigma_{E\theta P} = \text{elastic hoop buckling stress of imperfect curved panel, N/cm}^2 \text{ (kgf/cm}^2 \text{, lbf/in}^2\text{)}$$

$$= \frac{q_{CE\theta P}(r + 0.5t)}{t} K_\theta$$

- K_θ = coefficient to account for the strengthening effect of ring stiffener from 4/13.3
- $q_{CE\theta P}$ = elastic buckling pressure, N/cm² (kgf/cm², lbf/in²)
- $$= \frac{Et}{n^2 + k\alpha^2 - 1} \left[\frac{(n^2 + \alpha^2 - 1)^2}{12(1 - \nu^2)} \left(\frac{t}{r}\right)^2 + \frac{\alpha^4}{(n^2 + \alpha^2)^2} \right]$$
- n = circumferential wave number starting at $0.5N_s$ and increasing until a minimum value of $q_{CE\theta P}$ is attained
- α = $\frac{\pi r}{\ell}$
- k = 0 for lateral pressure
= 0.5 for hydrostatic pressure
- ℓ = length between adjacent ring stiffeners (unsupported)
- r = mean radius of cylindrical shell, cm (in.)
- t = thickness of cylindrical shell, cm (in.)
- E = modulus of elasticity, 2.06×10^7 N/cm² (2.1×10^6 kgf/cm², 30×10^6 lbf/in²) for steel
- N_s = number of stringers

7 Ring and Stringer-stiffened Shells

7.1 Bay Buckling Limit State

For the buckling limit state of ring and stringer-stiffened cylindrical shells between adjacent ring stiffeners subjected to axial compression, bending moment and external pressure, the following strength criteria is to be satisfied:

$$\left(\frac{\sigma_x}{\eta \sigma_{CxB} A_e / A} \right)^2 - \varphi_B \left(\frac{\sigma_x}{\eta \sigma_{CxB} A_e / A} \right) \left(\frac{\sigma_\theta}{\eta \sigma_{C\theta B}} \right) + \left(\frac{\sigma_\theta}{\eta \sigma_{C\theta B}} \right)^2 \leq 1$$

where

- σ_x = compressive stress in longitudinal direction from 4/13.1, N/cm² (kgf/cm², lbf/in²)
- σ_θ = compressive hoop stress from 4/13.3, N/cm² (kgf/cm², lbf/in²)
- σ_{CxB} = critical buckling stress for axial compression or bending moment from 4/7.3, N/cm² (kgf/cm², lbf/in²)
- $\sigma_{C\theta B}$ = critical buckling stress for external pressure from 4/7.5, N/cm² (kgf/cm², lbf/in²)
- φ_B = coefficient to reflect interaction between longitudinal and hoop stresses (negative values are acceptable)
- $$= \frac{1.5(\sigma_{CxB} + \sigma_{C\theta B})}{\sigma_0} - 2.0$$
- A_e = effective cross sectional area, cm² (in²)
- $$= A_s + s_{em}t$$
- A = total cross sectional area, cm² (in²)
- $$= A_s + st$$

- A_s = cross sectional area of stringer stiffener, cm² (in²)
 t = thickness of cylindrical shell, cm (in.)
 s = spacing of stringers
 s_{em} = modified effective shell plate width
 $= \left(\frac{1.05}{\lambda_m} - \frac{0.28}{\lambda_m^2} \right) s$ for $\lambda_m > 0.53$
 $= s$ for $\lambda_m \leq 0.53$
 λ_m = modified reduced slenderness ratio
 $= \sqrt{\frac{\sigma_{CxB}}{\sigma_{Exp}}}$
 σ_{Exp} = elastic buckling stress for imperfect curved panel between adjacent stringer stiffeners subjected to axial compression from 4/5.3, N/cm² (kgf/cm², lbf/in²)
 σ_0 = specified minimum yield point, N/cm² (kgf/cm², lbf/in²)
 η = maximum allowable strength utilization factor of shell buckling, as specified in Subsection 1/11 and 4/1.7, for ring and stringer-stiffened cylindrical shells in axial compression or external pressure, whichever is the lesser

7.3 Critical Buckling Stress for Axial Compression or Bending Moment

The critical buckling stress of ring and stringer-stiffened cylindrical shells subjected to axial compression or bending may be taken as:

$$\sigma_{CxB} = \begin{cases} \sigma_{Exp} & \text{for } \sigma_{Exp} \leq P_r \sigma_0 \\ \sigma_0 \left[1 - P_r (1 - P_r) \frac{\sigma_0}{\sigma_{Exp}} \right] & \text{for } \sigma_{Exp} > P_r \sigma_0 \end{cases}$$

where

- P_r = proportional linear elastic limit of the structure, which may be taken as 0.6 for steel
 σ_{Exp} = elastic compressive buckling stress of imperfect stringer-stiffened shell, N/cm² (kgf/cm², lbf/in²)
 $= \sigma_c + \sigma_s$
 σ_s = elastic compressive buckling stress of stringer-stiffened shell, N/cm² (kgf/cm², lbf/in²)
 $= \rho_{xB} \frac{0.605 E \left(\frac{t}{r} \right)}{1 + \frac{A_s}{st}}$
 ρ_{xB} = 0.75
 σ_c = elastic buckling stress of column, N/cm² (kgf/cm², lbf/in²)
 $= \frac{\pi^2 EI_{se}}{\ell^2 (A_s + s_e t)}$

- I_{se} = moment of inertia of stringer stiffener plus associated effective shell plate width, cm^4 (in^4)

$$= I_s + A_s z_{st}^2 \frac{s_e t}{A_s + s_e t} + \frac{s_e t^3}{12}$$
- I_s = moment of inertia of stringer stiffener about its own centroid axis, cm^4 (in^4)
 z_{st} = distance from centerline of shell to the centroid of stringer stiffener, cm (in.)
 A_s = cross sectional area of stringer stiffener, cm^2 (in^2)
 s_e = reduced effective width of shell, cm (in.)

$$= \frac{0.53}{\lambda_{xP}} s \quad \text{for } \lambda_{xP} > 0.53$$

$$= s \quad \text{for } \lambda_{xP} \leq 0.53$$
- s = shell plate width between adjacent stringers, cm (in.)
 λ_{xP} = reduced shell slenderness ratio

$$= \sqrt{\frac{\sigma_0}{\sigma_{Exp}}}$$
- σ_{Exp} = elastic compressive buckling stress for imperfect curved panel between adjacent stringer stiffeners from 4/5.3, N/cm^2 (kgf/cm^2 , lbf/in^2)
 ℓ = length between adjacent ring stiffeners (unsupported), cm (in.)
 r = mean radius of cylindrical shell, cm (in.)
 t = thickness of cylindrical shell, cm (in.)
 E = modulus of elasticity, $2.06 \times 10^7 \text{ N/cm}^2$ ($2.1 \times 10^6 \text{ kgf/cm}^2$, $30 \times 10^6 \text{ lbf/in}^2$) for steel
 σ_0 = specified minimum yield point, N/cm^2 (kgf/cm^2 , lbf/in^2)

7.5 Critical Buckling Stress for External Pressure

The critical buckling stress for ring and stringer-stiffened cylindrical shells subjected to external pressure may be taken as

$$\sigma_{C\theta B} = (\sigma_{C\theta R} + \sigma_{sp}) K_p \leq \sigma_0$$

where

- $\sigma_{C\theta R}$ = critical hoop buckling stress for the unstiffened shell from 4/3.5, N/cm^2 (kgf/cm^2 , lbf/in^2)
 σ_{sp} = collapse hoop stress for a stringer stiffener plus its associated shell plating, N/cm^2 (kgf/cm^2 , lbf/in^2)

$$= \frac{q_s (r + 0.5t)}{t} K_\theta$$
- K_θ = coefficient to account for the strengthening effect of ring stiffener from 4/13.3
 q_s = collapse pressure of a stringer stiffener plus its associated shell plating, N/cm^2 (kgf/cm^2 , lbf/in^2)

$$= \frac{16}{s\ell^2} A_s |z_{st}| \sigma_0$$
- z_{st} = distance from centerline of shell to the centroid of stringer stiffener, cm (in.)

- A_s = cross sectional area of stringer stiffener, cm² (in²)
 K_p = effective pressure correction factor
 = $0.25 + \frac{0.85}{500}g$ for $g \leq 500$
 = 1.10 for $g > 500$
 g = geometrical parameter
 = $2\pi \frac{\ell^2 A_s}{N_s I_s}$
 I_s = sectional moment area of inertia of stringer stiffener, cm⁴ (in⁴)
 N_s = number of stringer stiffeners
 ℓ = length between adjacent ring stiffeners (unsupported), cm (in.)
 r = mean radius of cylindrical shell, cm (in.)
 t = thickness of cylindrical shell, cm (in.)
 σ_0 = specified minimum yield point, N/cm² (kgf/cm², lbf/in²)

7.7 General Buckling

The general buckling of a ring and stringer-stiffened cylindrical shell involves the collapse of one or more ring stiffeners together with shell plating plus stringer stiffeners and should be avoided due to its catastrophic consequences. The ring and stringer stiffeners are to be proportioned, in accordance with 4/15.1 and 4/15.3, to exclude the general buckling failure mode.

9 Local Buckling Limit State for Ring and Stringer Stiffeners

9.1 Flexural-Torsional Buckling

When the torsional stiffness of the stiffeners is low and the slenderness ratio of the curved panels is relatively high, the stiffeners can suffer torsional-flexural buckling (tripping) at a stress level lower than that resulting in local or bay buckling. When the stiffener buckles, it loses a large part of its effectiveness to maintain the initial shape of the shell. The buckled stiffener sheds load to the shell, and therefore, should be suppressed.

The flexural-torsional buckling limit state of stringer stiffeners is to satisfy the ultimate state limit given below:

$$\frac{\sigma_x}{\eta\sigma_{CT}} \leq 1$$

where

- σ_x = compressive stress in the longitudinal direction from 4/13.1, N/cm² (kgf/cm², lbf/in²)
 σ_{CT} = flexural-torsional buckling stress with respect to axial compression of a stiffener, including its associated shell plating, may be obtained from the following equations:
 = $\begin{cases} \sigma_{ET} & \text{if } \sigma_{ET} \leq P_r \sigma_0 \\ \sigma_0 \left[1 - P_r (1 - P_r) \frac{\sigma_0}{\sigma_{ET}} \right] & \text{if } \sigma_{ET} > P_r \sigma_0 \end{cases}$
 σ_0 = specified minimum yield point of the stringer under consideration, N/cm² (kgf/cm², lbf/in²)

- P_r = proportional linear elastic limit of the structure, which may be taken as 0.6 for steel
- σ_{ET} = ideal elastic flexural-torsional buckling stress, N/cm² (kgf/cm², lbf/in²)
- $$= \frac{\frac{K}{2.6} + \left(\frac{n\pi}{\ell}\right)^2 \Gamma + \frac{C_0}{E} \left(\frac{\ell}{n\pi}\right)^2}{I_0 + \frac{C_0}{\sigma_{CL}} \left(\frac{\ell}{n\pi}\right)^2} E$$
- K = St. Venant torsion constant for the stiffener cross-section, excluding the associated shell plating, cm⁴ (in⁴)
- $$= \frac{b_f t_f^3 + d_w t_w^3}{3}$$
- I_0 = polar moment of inertia of the stiffener, excluding the associated shell plating, cm⁴ (in⁴)
- $$= I_y + m I_z + A_s (y_0^2 + z_0^2)$$
- I_y, I_z = moment of inertia of the stiffener about the y- and z-axis, respectively, through the centroid of the longitudinal, excluding the shell plating (y-axis perpendicular to the web, see Section 4, Figure 2), cm⁴ (in⁴)
- $$m = 1.0 - u \left(0.7 - 0.1 \frac{d_w}{b_f} \right)$$
- u = non-symmetry factor
- $$= 1 - 2 \frac{b_1}{b_f}$$
- y_0 = horizontal distance between centroid of stiffener and web plate centerline (see Section 4, Figure 2), cm (in.)
- z_0 = vertical distance between centroid of stiffener and its toe (see Section 4, Figure 2), cm (in.)
- d_w = depth of the web, cm (in.)
- t_w = thickness of the web, cm (in.)
- b_f = total width of the flange/face plate, cm (in.)
- b_1 = smaller outstanding dimension of flange or face plate with respect to web's centerline, cm (in.)
- t_f = thickness of the flange or face plate, cm (in.)
- $$C_0 = \frac{Et^3}{3s}$$
- Γ \cong warping constant, cm⁶ (in⁶)
- $$\cong m I_{xf} d_w^2 + \frac{d_w^3 t_w^3}{36}$$
- $$I_{xf} = \frac{t_f b_f^3}{12} \left(1.0 + 3.0 \frac{u^2 d_w t_w}{A_s} \right), \text{ cm}^4 \text{ (in}^4\text{)}$$

- σ_{CL} = critical buckling stress for associated shell plating corresponding to n -half waves, N/cm² (kgf/cm², lbf/in²)
- $$= \frac{\pi^2 E \left(\frac{n}{\alpha} + \frac{\alpha}{n} \right)^2 \left(\frac{t}{s} \right)^2}{12(1 - \nu^2)}$$
- α = ℓ/s
- n = number of half-waves which yields the smallest σ_E
- σ_0 = specified minimum yield point of the material, N/cm² (kgf/cm², lbf/in²)
- E = modulus of elasticity, 2.06×10^7 N/cm² (2.1×10^6 kgf/cm², 30×10^6 lbf/in²) for steel
- s = spacing of stringer stiffeners, cm (in.)
- A_s = sectional area of stringer stiffener, excluding the associated shell plating, cm² (in²)
- t = thickness of shell plating, cm (in.)
- ℓ = length between adjacent ring stiffeners (unsupported), cm (in.)
- η = maximum allowable strength utilization factor, as specified in Subsection 1/11 and 4/1.7, for tripping of stringer stiffeners

9.3 Web Plate Buckling

The depth to thickness ratio of the web plate is to satisfy the limit given in 4/15.5.

9.5 Faceplate and Flange Buckling

The breadth to thickness ratio of the faceplate or flange is to satisfy the limit given in 4/15.7.

11 Beam-Column Buckling

A cylindrical shell subjected to axial compression, or bending moment or both; with or without external pressure, is to be designed to resist beam-column buckling. Beam-column buckling is to be assessed if:

$$\lambda_{xE} \geq 0.50$$

where

$$\lambda_{xE} = \text{slenderness ratio of cylindrical shell}$$

$$= \sqrt{\sigma_0 / \sigma_{E(C)}}$$

$$\sigma_{E(C)} = \text{Euler buckling stress, N/cm}^2 \text{ (kgf/cm}^2 \text{, lbf/in}^2 \text{)}$$

$$= \pi^2 E r_i^2 / (kL)^2$$

$$r_i = \text{radius of gyration of the cross section of the cylindrical shell}$$

$$= \sqrt{\frac{I_T}{A_T}}$$

$$I_T = \text{moment of inertia of the cross section of the cylindrical shell; if the cross section is variable along the length, the minimum value is to be used, cm}^4 \text{ (in}^4 \text{)}$$

$$A_T = \text{cross sectional area of the cylindrical shell; if the cross section is variable along the length, the minimum value is to be used, cm}^2 \text{ (in}^2 \text{)}$$

$$kL = \text{effective length of the cylinder, as defined in 2/3.3}$$

$$E = \text{modulus of elasticity, } 2.06 \times 10^7 \text{ N/cm}^2 \text{ (} 2.1 \times 10^6 \text{ kgf/cm}^2 \text{, } 30 \times 10^6 \text{ lbf/in}^2 \text{) for steel}$$

The beam-column buckling limit state of a cylindrical shell subjected to axial compression, or bending or both; with or without external pressure, is to satisfy the following criteria at all cross-sections along its length:

$$\frac{\sigma_a}{\eta\sigma_{Ca}} + \frac{\sigma_b}{\eta\sigma_{Cx}[1 - \sigma_a/(\eta\sigma_{E(C)})]} \leq 1$$

where

σ_a = calculated axial normal compressive stress from 4/13.1, N/cm² (kgf/cm², lbf/in²)

σ_b = calculated bending stress from 4/13.1, N/cm² (kgf/cm², lbf/in²)

σ_{Ca} = critical compressive buckling stress, N/cm² (kgf/cm², lbf/in²)

$$= \begin{cases} \sigma_{E(C)} & \text{if } \sigma_{E(C)} \leq P_r\sigma_{Cx} \\ \sigma_{Cx} \left[1 - P_r(1 - P_r) \frac{\sigma_{Cx}}{\sigma_{E(C)}} \right] & \text{if } \sigma_{E(C)} > P_r\sigma_{Cx} \end{cases}$$

σ_{Cx} = critical axial or bending buckling stress of bay

for ring-stiffened cylindrical shell

$$= \sigma_{CxR} \left[0.5\phi_R \left(\frac{\sigma_\theta}{\sigma_{C\theta R}} \right) + \sqrt{1 - (1 - 0.25\phi_R^2) \left(\frac{\sigma_\theta}{\sigma_{C\theta R}} \right)^2} \right]$$

for ring and stringer-stiffened cylindrical shell

$$= \frac{A_e}{A} \sigma_{CxB} \left[0.5\phi_B \left(\frac{\sigma_\theta}{\sigma_{C\theta B}} \right) + \sqrt{1 - (1 - 0.25\phi_B^2) \left(\frac{\sigma_\theta}{\sigma_{C\theta B}} \right)^2} \right]$$

σ_θ = calculated hoop stress from 4/13.3, N/cm² (kgf/cm², lbf/in²)

A = cross sectional area as defined in 4/7.1

A_e = effective cross sectional area as defined in 4/7.1

η = maximum allowable strength utilization factor, as specified in Subsection 1/11 and 4/1.7, for column buckling

σ_{CxR} , $\sigma_{C\theta R}$, ϕ_R , σ_{CxB} , $\sigma_{C\theta B}$ and ϕ_B are as defined in Subsections 4/3 and 4/7.

13 Stress Calculations

13.1 Longitudinal Stress

The longitudinal stress in accordance with beam theory may be taken as:

$$\sigma_x = \sigma_a + \sigma_b$$

where

σ_a = stress due to axial force, N/cm² (kgf/cm², lbf/in²)

$$= \frac{P}{2\pi r t (1 + \delta)}$$

σ_b = stress due to bending moment, N/cm² (kgf/cm², lbf/in²)

$$= \frac{M}{\pi r^2 t (1 + \delta)}$$

P	=	axial force, N (kgf, lbf)
M	=	bending moment, N-cm (kgf-cm, lbf-in)
δ	=	$\frac{A_{st}}{st}$
A_{st}	=	cross sectional area of stringer stiffener, cm ² (in ²)
s	=	shell plate width between adjacent stringer stiffeners, cm (in.)
r	=	mean radius of cylindrical shell, cm (in.)
t	=	thickness of cylindrical shell, cm (in.)

13.3 Hoop Stress

The hoop stress may be taken as

At midway of shell between adjacent ring stiffeners:

$$\sigma_{\theta} = \frac{q(r + 0.5t)}{t} K_{\theta}$$

At inner face of ring flange, (i.e., radius r_F in Section 4, Figure 2):

$$\sigma_{\theta R} = \frac{q(r + 0.5t)}{t} \frac{r}{r_F} K_{\theta R}$$

where

$$K_{\theta} = 1 - \frac{1 - k\nu}{1 + t(t_w + \ell \varpi) / \bar{A}_R} G_{\alpha}$$

$$K_{\theta R} = \frac{1 - k\nu}{1 + \bar{A}_R / [t(t_w + \ell \varpi)]}$$

$$\bar{A}_R = A_R \left(\frac{r}{r_R} \right)^2, \text{ cm}^2 \text{ (in}^2\text{)}$$

$$\varpi = \frac{\cosh 2\alpha - \cos 2\alpha}{\alpha(\sinh 2\alpha + \sin 2\alpha)} \geq 0$$

$$\alpha = \frac{\ell}{1.56\sqrt{rt}}$$

$$G_{\alpha} = 2 \frac{\sinh \alpha \cos \alpha + \cosh \alpha \sin \alpha}{\sinh 2\alpha + \sin 2\alpha} \geq 0$$

$$k = \begin{cases} N_x / N_{\theta} & \text{for lateral pressure} \\ N_x / N_{\theta} + 0.5 & \text{for hydrostatic pressure} \end{cases}$$

$$A_R = \text{cross sectional area of ring stiffener, cm}^2 \text{ (in}^2\text{)}$$

$$q = \text{external pressure, N/cm}^2 \text{ (kgf/cm}^2\text{, lbf/in}^2\text{)}$$

$$N_x = \text{axial load per unit length, excluding the capped-end actions due to hydrostatic pressure, N/cm (kg/cm, lbf/in)}$$

$$N_{\theta} = \text{circumferential load per unit length, N/cm (kg/cm, lbf/in)}$$

$$r = \text{mean radius of cylindrical shell, cm (in.)}$$

- r_R = radius to centroid of ring stiffener, as defined in Section 4, Figure 2, cm (in.)
 r_F = radius to inner face of ring flange, as defined in Section 4, Figure 2, cm (in.)
 t = thickness of cylindrical shell, cm (in.)
 t_w = stiffener web thickness, cm (in.)
 ℓ = length between adjacent ring stiffeners (unsupported), cm (in.)
 ν = Poisson's ratio

r , r_R and r_F are described in Section 4, Figure 2.

15 Stiffness and Proportions

To fully develop the intended buckling strength of the assemblies of a stiffened cylindrical shell, ring and stringer stiffeners are to satisfy the following requirements for stiffness and proportions.

15.1 Stiffness of Ring Stiffeners

The moment of inertia of the ring stiffeners, i_r , together with the effective length of shell plating, ℓ_{eo} , should not be less than that given by the following equation:

$$i_r = \frac{\sigma_x(1 + \delta)tr_e^4}{500E\ell} + \frac{\sigma_\theta r_e^2 \ell t}{2EK_\theta} \left(1 + \frac{z_e}{100r} \frac{E}{\eta\sigma_0 - \sigma_{\theta R}} \right)$$

where

- σ_x = compressive stress in longitudinal direction from 4/13.1, N/cm² (kgf/cm², lbf/in²)
 σ_θ = compressive hoop stress midway between adjacent ring stiffeners from 4/13.3, N/cm² (kgf/cm², lbf/in²)
 $\sigma_{\theta R}$ = compressive hoop stress at outer edge of ring flange from 4/13.3, N/cm² (kgf/cm², lbf/in²)
 δ = A_s/st
 i_r = moment of inertia of the ring stiffeners with associated effective shell length, ℓ_{eo}
 ℓ_{eo} = $1.56\sqrt{rt} \leq \ell$
 r_e = radius to the centroid of ring stiffener, accounting for the effective length of shell plating, cm (in.)
 z_e = distance from inner face of ring flange to centroid of ring stiffener, accounting for the effective length of shell plating, cm (in.)
 K_θ = coefficient from 4/13.3
 σ_0 = specified minimum yield point, N/cm² (kgf/cm², lbf/in²)
 E = modulus of elasticity, 2.06×10^7 N/cm² (2.1×10^6 kgf/cm², 30×10^6 lbf/in²) for steel
 s = spacing of stringer stiffeners, cm (in.)
 A_s = cross sectional area of stringer, cm² (in²)
 t = thickness of shell plating, cm (in.)
 ℓ = length between adjacent ring stiffeners (unsupported), cm (in.)
 η = maximum allowable strength utilization factor for stiffened cylindrical shells subjected to external pressure

15.3 Stiffness of Stringer Stiffeners

The moment of inertia of the stringer stiffeners, i_s , with effective breadth of shell plating, s_{em} , is not to be less than:

$$i_o = \frac{st^3}{12(1-\nu^2)} \gamma_0$$

where

$$\begin{aligned} \gamma_0 &= (2.6 + 4.0\delta)\alpha^2 + 12.4\alpha - 13.2\alpha^{1/2} \\ \delta &= A_s/(st) \\ \alpha &= \ell/s \\ s &= \text{spacing of stringer stiffeners, cm (in.)} \\ t &= \text{thickness of shell plate, cm (in.)} \\ \nu &= \text{Poisson's ratio} \\ A_s &= \text{cross sectional area of stringer stiffener, cm}^2 \text{ (in}^2\text{)} \\ \ell &= \text{length between adjacent ring stiffeners (unsupported), cm (in.)} \end{aligned}$$

15.5 Proportions of Webs of Stiffeners

The depth to thickness ratio of webs of stiffeners is to satisfy the applicable limit given below.

$$d_w/t_w \leq 1.5(E/\sigma_0)^{1/2} \quad \text{for angles and tee bars}$$

$$d_w/t_w \leq 0.85(E/\sigma_0)^{1/2} \quad \text{for bulb plates}$$

$$d_w/t_w \leq 0.4(E/\sigma_0)^{1/2} \quad \text{for flat bars}$$

where

$$\sigma_0 = \text{specified minimum yield point, N/cm}^2 \text{ (kgf/cm}^2, \text{ lbf/in}^2\text{)}$$

$$E = \text{modulus of elasticity, } 2.06 \times 10^7 \text{ N/cm}^2 \text{ (} 2.1 \times 10^6 \text{ kgf/cm}^2, 30 \times 10^6 \text{ lbf/in}^2\text{) for steel}$$

d_w and t_w are as defined in Section 4, Figure 2.

15.7 Proportions of Flanges and Faceplates

The breadth to thickness ratio of flanges and faceplates of stiffeners is to satisfy the limit given below.

$$b_2/t_f \leq 0.4(E/\sigma_0)^{1/2}$$

where

$$b_2 = \text{larger outstanding dimension of the flange/faceplate, cm (in.)}$$

$$t_f = \text{thickness of flange/face plate, cm (in.)}$$

$$\sigma_0 = \text{specified minimum yield point, N/cm}^2 \text{ (kgf/cm}^2, \text{ lbf/in}^2\text{)}$$

$$E = \text{modulus of elasticity, } 2.06 \times 10^7 \text{ N/cm}^2 \text{ (} 2.1 \times 10^6 \text{ kgf/cm}^2, 30 \times 10^6 \text{ lbf/in}^2\text{) for steel}$$

SECTION 5 Tubular Joints

1 General

This Section provides ultimate strength criteria for tubular joints. Each joint should be considered as being comprised of a number of independent chord/brace intersections, and the ultimate strength limit state of each intersection is to be checked against the design requirement. For a multi-planar joint, each plane should be subjected to separate consideration and categorization.

The formulations provided in this Section may be used to assess the ultimate strength limit of tubular joints. Alternatively, the ultimate strength of a tubular joint may be determined based on either well-documented experimental data or a verified analytical approach.

1.1 Geometry of Tubular Joints

The geometry of a simple joint is depicted in Section 5, Figure 1.

**FIGURE 1
Geometry of Tubular Joints**

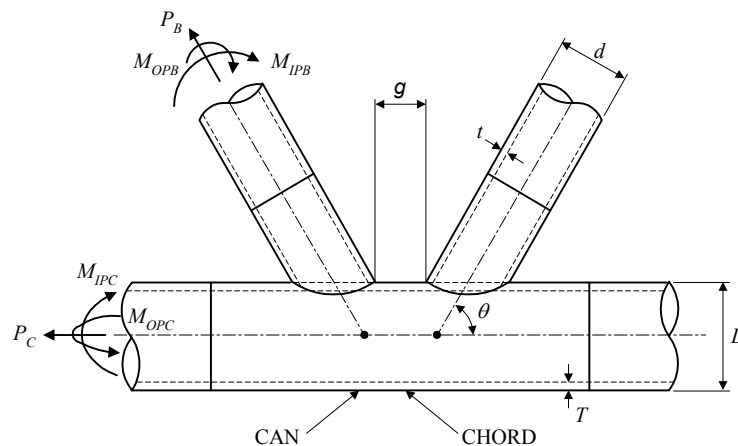

The formulations in this Section are applicable for the strength assessment of tubular joints in the following geometric ranges:

$$\tau \leq 1.20$$

$$0.20 \leq \beta \leq 1.00$$

$$10 \leq \gamma \leq 50$$

$$-0.5 \leq g/D$$

where

$$\begin{aligned} \tau &= \text{ratio of brace wall thickness to chord wall thickness} \\ &= t/T \end{aligned}$$

- β = ratio of brace outer diameter to chord outer diameter
 = d/D
 γ = ratio of chord outer diameter to two times of chord wall thickness
 = $D/(2T)$
 g = gap, cm (in.)

1.3 Loading Application

The ultimate strength criteria are provided for the following loads and load effects:

- Axial load in a brace member, P_B
- In-plane bending moment in a brace member, M_{IPB}
- Out-of-plane bending moment in a brace member, M_{OPB}
- Axial load in a chord member, P_C
- In-plane bending moment in a chord member, M_{IPC}
- Out-of-plane bending moment in a chord member, M_{OPC}
- Combinations of the above mentioned loads and load effects.

1.5 Failure Modes

The mode of failure of a tubular joint depends on the joint configuration, joint geometry and loading condition. These modes include:

Local failure of the chord:

- Plastic failure of the chord wall in the vicinity of the brace.
- Cracking leading to rupture of the brace from the chord.
- Local buckling in compression areas of the chord.

Global failure of the chord:

- Ovalization of the chord cross-section.
- Beam bending failure.
- Beam shear failure between adjacent braces.

In addition, a member can fail away from the brace-chord joint due to chord or brace overloading. These failure modes can be established following the approach described in Section 2 for tubular members.

1.7 Classification of Tubular Joints

Each chord/brace intersection is to be classified as T/Y, K or X, according to their configuration and load pattern for each load case. The following guidelines are to be used to classify tubular joints:

- For two or three brace members on one side of a chord, the classification is dependent on the equilibrium of the axial load components in the brace members. If the resultant shear on the chord member is balanced or algebraically around zero, the joint is to be categorized as a K. If the shear balance check is not met, the joint is to be categorized (downgraded) as a T&Y, as shown in Section 5, Figure 2. However, for braces that carry part of their load as K joints and part as Y or X joints, interpolation is to be used based on the proportion of each joint. The procedure for interpolation in such cases is to be specially agreed upon with [ABS](#).
- For multi-brace joints with braces on either side of the chord, as shown in Section 5, Figure 2, care is to be taken in assigning the appropriate category. For example, a K classification would be valid if the net shear across the chord is balanced or algebraically zero. In contrast, if the loads in all of the braces are tensile, even an X classification may be too optimistic due to the increased ovalization effect. Classification in these cases is to be specially agreed with [ABS](#).

FIGURE 2
Examples of Tubular Joint Categorization

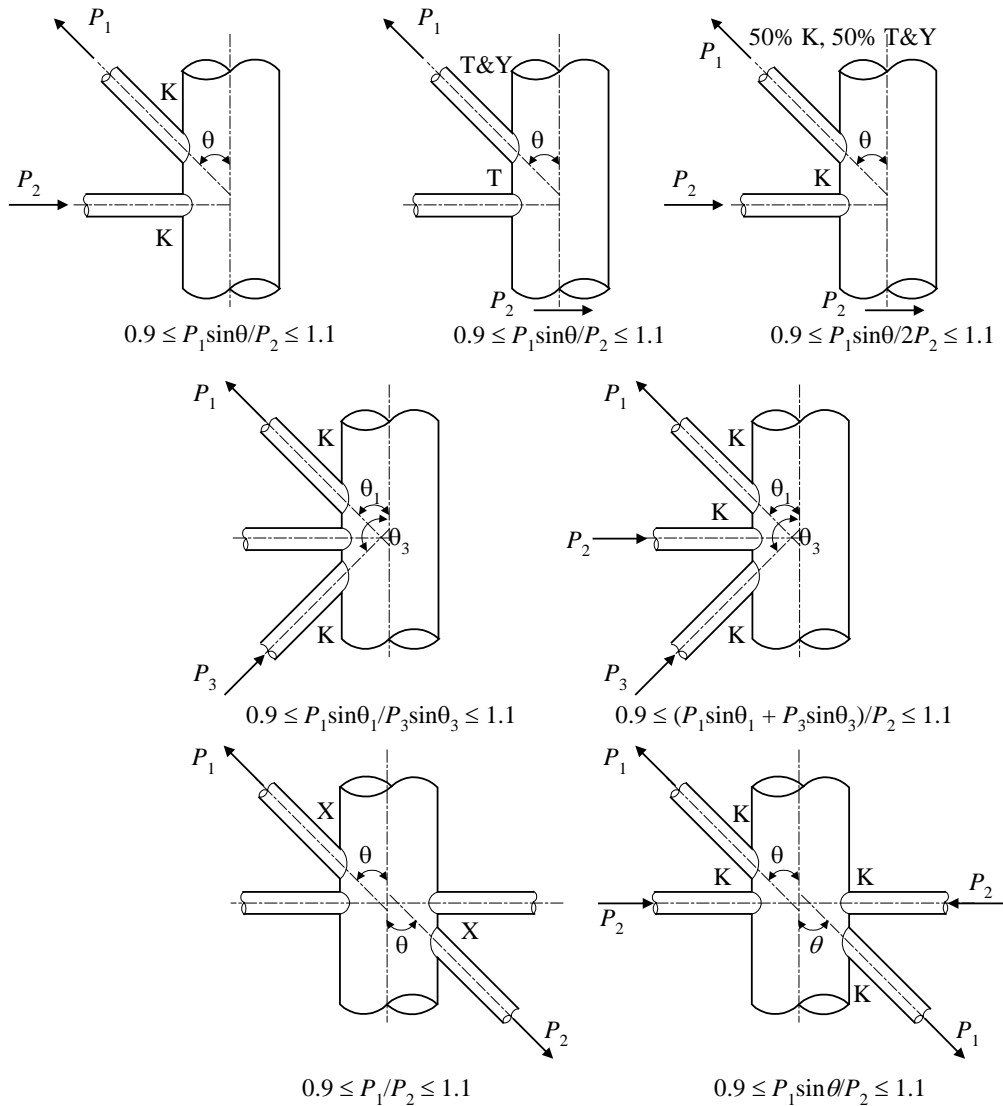

1.9 Adjustment Factor

For the maximum allowable strength utilization factor, η , defined in Subsection 1/11, the adjustment factor is to take the following value:

$$\psi = 1.0$$

3 Simple Tubular Joints

3.1 Joint Capacity

The strength of a simple joint without overlap of braces and having no gussets, grout or stiffeners is to be calculated based on the following:

$$P_u = \frac{\sigma_{0c} T^2}{\sin \theta} Q_u Q_f$$

$$M_u = \frac{\sigma_{oc} T^2 d}{\sin \theta} Q_u Q_f$$

where

- P_u = critical joint axial strength, N (kgf, lbf)
- M_u = critical joint bending moment strength for in-plane and out-of plane bending, N-cm (kgf-cm, lbf-in)
- θ = brace angle measured from chord, as defined in Section 5, Figure 1
- Q_u = strength factor depending on the joint loading and classification, as determined in Section 5, Table 1
- Q_f = chord load factor
= $1 - \lambda \gamma A^2$
- λ = chord slenderness parameter
= 0.030 for brace axial load
= 0.045 for brace in-plane bending moment
= 0.021 for brace out-of-plane bending moment
- γ = ratio of chord outer radius to chord wall thickness
= $D/(2T)$
- A = chord utilization ratio
= $\frac{\sqrt{\sigma_{AC}^2 + \sigma_{IPC}^2 + \sigma_{OPC}^2}}{\eta \sigma_{oc}}$
- σ_{AC} = nominal axial stress in the chord member, N/cm² (kgf/cm², lbf/in²)
- σ_{IPC} = nominal in-plane bending stress in the chord member, N/cm² (kgf/cm², lbf/in²)
- σ_{OPC} = nominal out-of-plane bending stress in the chord member, N/cm² (kgf/cm², lbf/in²)
- σ_{oc} = specified minimum yield point of the chord member, N/cm² (kgf/cm², lbf/in²)
- D = chord outer diameter, cm (in.)
- T = chord thickness, cm (in.)
- d = brace outer diameter, cm (in.)
- η = maximum allowable strength utilization factor, as defined in Subsection 1/11 and 5/1.9

Axially loaded braces based on a combination of K, X and Y joints should take a weighted average of P_u depending on the proportion of each load.

TABLE 1
Strength Factor, Q_u

Joint Classification	Brace Load Effects			
	Axial Compression	Axial Tension	In-plane Bending	Out-of-plane Bending
K	$(0.5+12\beta)\gamma^{0.2} Q_\beta^{0.5} Q_g$	$(0.65+15.5\beta)\gamma^{0.2} Q_\beta^{0.5} Q_g$	$4.5\beta\gamma^{0.5}$	$3.2\gamma^{(0.5\beta)}$
T/Y	$(0.5+12\beta)\gamma^{0.2} Q_\beta^{0.5}$	$(0.65+15.5\beta)\gamma^{0.2} Q_\beta^{0.5}$	$4.5\beta\gamma^{0.5}$	$3.2\gamma^{(0.5\beta)}$
X	$(3.0+14.5\beta) Q_\beta$	$(3.3+16\beta) Q_\beta$	$5.0\beta\gamma^{0.5}$	$3.2\gamma^{(0.5\beta)}$

where

$$\begin{aligned}
 Q_\beta &= 0.3/[\beta(1 - 0.833\beta)] && \text{for } \beta > 0.6 \\
 &= 1.0 && \text{for } \beta \leq 0.6 \\
 Q_g &= 1 + 0.85 \exp(-4g/D) && \text{for } g/D \geq 0.0 \\
 g &= \text{gap, cm (in.)} \\
 \beta &= \text{ratio of brace outer diameter to chord outer diameter} \\
 &= d/D \\
 \gamma &= \text{ratio of chord outer diameter to two times of chord wall thickness} \\
 &= D/(2T)
 \end{aligned}$$

3.3 Joint Cans

The advantage of a thicker chord may be taken for axially-loaded T/Y and X joints. This only applies if the effective can length of each brace is at least twice the distance from the brace toe to the nearest transition from the can to the main member, plus the brace diameter (see Section 5, Figure 3).

FIGURE 3
Examples of Effective Can Length

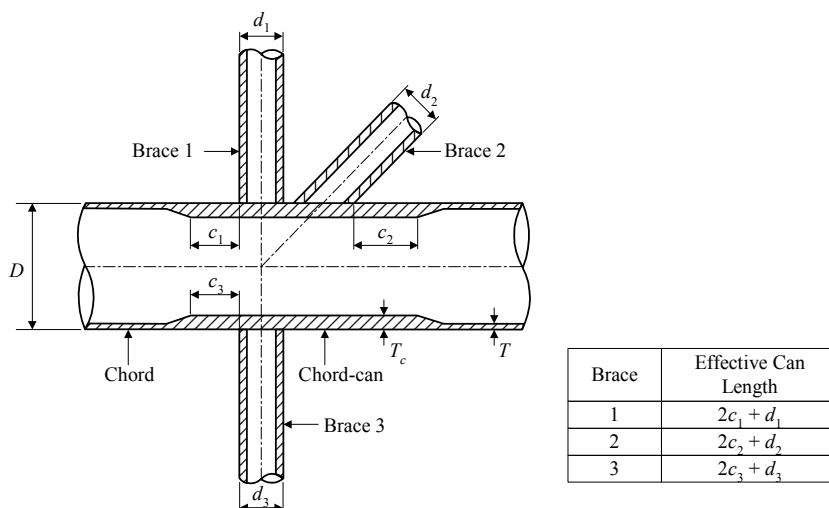

For K joints, the joint strength, P_u' , considering the additional effect of the can is to be calculated based on the following equation:

$$P_u' = [C + (1 - C)(T/T_c)^2]P_u$$

where

$$\begin{aligned}
 P_u &= \text{basic strength of the joint based on the can dimensions, N (kgf, lbf)} \\
 T_c &= \text{can thickness, cm (in.)} \\
 C &= \text{coefficient, which may not be taken greater than 1} \\
 &= L_c/(2.5D) && \text{for } \beta \leq 0.9 \\
 &= (4\beta - 3)L_c/(1.5D) && \text{for } \beta > 0.9 \\
 \beta &= \text{ratio of brace outer diameter to chord outer diameter} \\
 &= d/D \\
 D &= \text{chord outer diameter, cm (in.)}
 \end{aligned}$$

- T = chord wall thickness, cm (in.)
 L_c = effective length of can, cm (in.)

3.5 Strength State Limit

The strength of a tubular joint subjected to combined axial and bending loads is to satisfy the following state limit:

$$\left| \frac{P_D}{\eta P_u} \right| + \left(\frac{M_{IPB}}{\eta M_{uIPB}} \right)^2 + \left| \frac{M_{OPB}}{\eta M_{uOPB}} \right| \leq 1$$

where

- P_D = axial load in the brace member, N (kgf, lbf)
 M_{IPB} = in-plane bending moment in the brace member, N-cm (kgf-cm, lbf-in)
 M_{OPB} = out-of-plane bending moment in the brace member, N-cm (kgf-cm, lbf-in)
 P_u = tubular joint strength for brace axial load from 5/3.1 or 5/3.3, N (kgf, lbf)
 M_{uIPB} = tubular joint strength for brace in-plane bending moment from 5/3.1, N-cm (kgf-cm, lbf-in)
 M_{uOPB} = tubular joint strength for brace out-of-plane bending moment from 5/3.1, N-cm (kgf-cm, lbf-in)
 η = maximum allowable strength utilization factor, as specified in Subsection 1/11 and 5/1.9

5 Other Joints

5.1 Multiplanar Joints

The interaction between out-of-plane braces can be ignored, except for overlapping braces. It is recognized that for some load cases, particularly where braces lying in two perpendicular planes are loaded in the opposite sense (e.g., tension and compression), as shown in Section 5, Figure 4, joint strength can be significantly reduced. This strength reduction is primarily due to the additional ovalization occurring in the chord member. The design should account for this effect and is to consider applying a reduced allowable utilization factor, especially for critical, highly stressed, non-redundant joints. As required, the design of multiplanar joints loaded in opposite directions is to be based on suitable experimental data or nonlinear finite element analysis. Nonlinear finite element analysis is well-suited to investigate the effects of individual parameters such as load ratio, load sequence and interaction of out-of-plane braces.

FIGURE 4
Multiplanar Joints

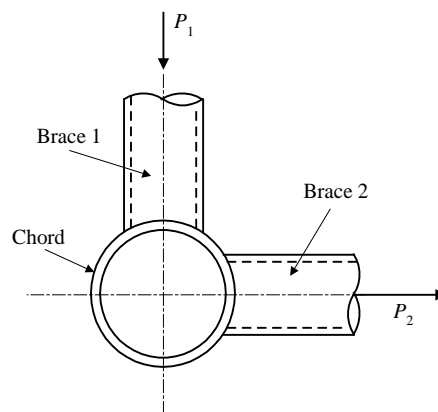

5.3 Overlapping Joints

Joints with braces that overlap in plane are to be checked using the same formula as for non-overlapping braces given in Subsection 5/3. However, an additional check is to be performed for the region of the overlap by considering the through brace as the chord member and the overlapping brace as the brace member.

The Q_g term for overlapped joints is to be based on the following equation:

$$Q_g = 0.13 + 0.65 \left(\frac{\sigma_{0b}}{\sigma_{0c}} \right) \tau \gamma^{0.5} \quad -0.50 \leq g/D \leq -0.05$$

where

σ_{0b}	=	specified minimum yield point of the brace member, N/cm ² (kgf/cm ² , lbf/in ²)
σ_{0c}	=	specified minimum yield point of the chord member, N/cm ² (kgf/cm ² , lbf/in ²)
τ	=	ratio of brace thickness to chord thickness
	=	t/T
γ	=	ratio of chord outer radius to chord wall thickness
	=	$D/(2T)$
g	=	gap, cm (in.)
D	=	chord outer diameter, cm (in.)

For $-0.5 < g/D < 0.0$, the value of Q_g should be estimated by linear interpolation between the value of Q_g calculated from the above expression and 1.85, the Q_g factor at $g/D = 0.0$.

Joints that overlap out-of-plane should be treated as simple joints and checked in accordance with Subsection 5/3. However, an additional check should be performed for the region of overlap by considering the through brace as the chord member and the overlapping brace as the brace member. The joint will be considered as a T/Y joint in this instance. The combined out-of-plane bending moment between these offset members is equivalent to an in-plane bending moment as defined for a simple T/Y joint. Similarly, the combined in-plane bending moment is equivalent to an out-of-plane bending moment, as defined for a simple T/Y joint.

5.5 Grouted Joints

Grouted joints can be classified into two types:

- i) Those with a fully grouted chord member and
- ii) Those with an inner steel sleeve with a grout filling the annulus between the two concentric tubular members.

Under axial compression, significant increases in joint strength have been recorded through test programs. Under axial tension, only modest strength enhancement is noted, which results primarily from the reduction in chord ovalization that occurs for the grouted specimen.

It is recommended that no benefit is taken from grouting or insertion of an inner sleeve under axial tension and bending in the strength assessment of a grouted joint. However, under axial compression, an enhancement in chord thickness may be available and an effective chord thickness may be obtained from the following equation.

$$T_e = T + T_p + T_g/18$$

where

T	=	chord thickness, cm (in.)
T_p	=	thickness of the inner tube, cm (in.)
T_g	=	thickness of the grout-filled section, cm (in.)
	=	$D/2 - (T + T_p)$, if fully grout-filled tube
D	=	outer diameter, cm (in.)

T_p and T_g are depicted in Section 5, Figure 5.

FIGURE 5
Grouted Joints

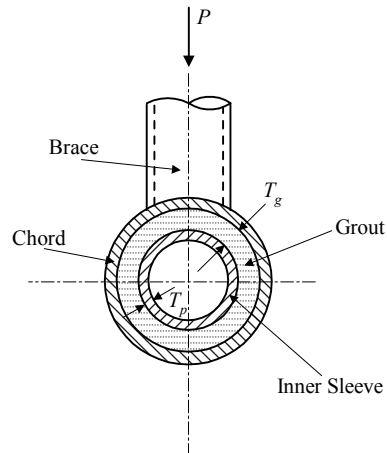

5.7 Ring-Stiffened Joints

As in the case of grouted joints, rings enhance the joint stiffness substantially. A ring-stiffened joint should be designed based on appropriate experimental or in-service evidence. In the absence of such evidence, an appropriate analytical check is to be pursued. As recommended by API RP WSD 2A, this check is to be performed by cutting sections that isolate groups of members, individual members and separate elements of the joint (e.g., gussets, diaphragms, stiffeners, welds in shear and surfaces subjected to punching shear), and verifying that realistic, assumed stress distributions satisfy equilibrium without exceeding the allowable stress of the material (e.g., the strength of all elements is sufficient to resist the applied loading).

As needed, the design of a ring-stiffened tubular joint is also to be based on suitable experimental data or nonlinear finite element analysis. Nonlinear finite element analysis is ideally suited for sensitivity studies, which investigate the effects of individual parameters such as the geometry, location and number of stiffeners.

5.9 Cast Joints

Where the use of cast joints is considered, assistance from qualified specialists is to be sought. This is particularly relevant for optimized cast joints where unusually demanding design criteria are proposed. Nonlinear finite element analysis is also to be performed, giving particular consideration to the geometric and material characteristics of cast joints, including the effects of casting geometry, stress-strain relationships and casting defects.

In addition, it should be recognized that the performance of cast joints beyond first yield may not be similar to that achieved in welded joints. The post-yield behavior of cast joints should be investigated to ensure that the reserve strength and ductility against total collapse are comparable to those of welded joints.



APPENDIX 1 Review of Buckling Analysis by Finite Element Method (FEM)

1 General

This Appendix, in conjunction with API Bulletin 2V, provides guidance on the review of buckling analysis using FEM. If appropriate documentation is presented, proven numerical methods to establish the buckling strength of structural components subjected to various loads and their combinations are accepted as an alternative to the formulations presented in the previous Sections of this Guide. In some cases, especially those involving novel structural designs and loading situations, reliance on such analytical methods are to be pursued to provide added assurance of a proposed design's adequacy. One widely-accepted method relies on the use of FEM analysis, which allows the designer to model the geometry; material properties; imperfections (such as out-of-roundness), fabrication-induced residual stresses, misalignment and corrosion defects; as well as boundary conditions.

Key issues in an FEM analysis include the selection of the computer program, the determination of the loads and boundary conditions, development of the mathematical model, choice of element types, design of the mesh, solution procedures and verification and validation. Numerous decisions are to be made during this analysis process.

This Appendix emphasizes some important aspects that should be satisfied in determining the buckling strength by FEM analysis.

3 Engineering Model

The engineering model for buckling analysis is a simplification and idealization of an actual physical structural component. Hence, it is crucial that the modeling process is undertaken correctly, since the FEM analysis cannot improve on a poor engineering model.

The rationale for the following aspects is to be appropriately described and justified:

- *Extent of the model.* The model should include the main features of the physical structure related to buckling behavior and capture all relevant failure modes.
- *Geometry.* The use of a full model is preferred in the FEM buckling analysis. Symmetric conditions may be utilized to reduce the size of finite element model, if appropriate.
- *Material properties.* Material nonlinearity may need to be considered in some circumstances, particularly in order to account for the effects of residual stresses.
- *Imperfections.* Imperfections may remarkably reduce the buckling strength of structural components. For this reason, the imperfections should be included.
- *Loads.* All possible loads and their combinations are to be considered.
- *Boundary conditions.* Boundary conditions are the constraints applied to the model. The boundary conditions should suitably reflect the constraint relationship between the structural component and its surroundings.

5 FEM Analysis Model

The FEM analysis model is translated from the engineering model. The rationale for the following items should be appropriately described and justified:

- *Element types.* Finite element types are specialized and can only simulate a limited number of response types. The choice of element types should be best suited to the problem.
- *Mesh design.* The discretization of a structure into a number of finite elements is one of the most critical tasks in finite element modeling and often a difficult one. The following parameters need to be considered in designing the layout of elements: mesh density, mesh transitions and the stiffness ratio of adjacent elements. As a general guidance, a finer mesh should be used in areas of high stress gradient. The performance of elements degrades as they become more skewed. If the mesh is graded, rather than uniform, the grading should be done in a way that minimizes the difference in size between adjacent elements.
- *Loads.* Typical structural loads and load effects in finite element models are forces, pressure load, gravity, body forces, prescribed displacements and temperatures. The loads and load effects may be applied or translated to nodes (e.g., nodal forces and body forces), element edges or faces (e.g., distributed line loads, pressure) and the entire model (e.g., gravity loads).
- *Boundary conditions.* Generally, the support condition assumed for the degree of freedom concerned is idealized as completely rigid or completely free. In reality, the support condition is usually somewhere in between.

7 Solution Procedures

Two types of solution procedures are usually employed in buckling analysis (e.g., eigenvalue buckling analysis and nonlinear buckling analysis).

Eigenvalue buckling analysis predicts the theoretical buckling strength (the bifurcation point) of an ideal linear elastic structure. However, imperfections and nonlinearities prevent most real structures from achieving their theoretical elastic buckling strength. Thus, eigenvalue buckling analysis often yields unconservative results and should generally not be used in actual structural design.

The nonlinear buckling analysis employs a nonlinear static analysis with gradually increasing loads to seek the load level at which the structure becomes unstable. The basic approach in a nonlinear buckling analysis is to constantly apply incremental loads until the solution begins to diverge. The load increments should be sufficiently fine to ensure the accuracy of the prediction.

The sequence of applied loads may influence the results. If the sequence is unknown, several tests should be performed to make sure that the results represent the worst case scenario.

The analysis may be extended into the post-buckling range by activating, for example, the *arc-length* method. Use this feature to trace the load-deflection curve through regions of “snap-through” and “snap-back” response.

9 Verification and Validation

It is necessary to perform verification and validation for the FEM analysis results to ensure that the loading, buckling strength and acceptance criteria are suitably considered.

- *Results and acceptance criteria*

The results should be presented so that they can be easily compared with the design/acceptance criteria and validated based on appropriate experimental or in-service evidence.

A statement confirming that all quality assessment checks, as required to confirm that a buckling analysis has been executed satisfactorily, should be included.

- *Analysis model*

In case of discrepancies in the results, the model and loading applied to the model should be reviewed as part of the investigation into the source of the problem. The appropriateness of the model, types of loads and load combination, load sequence, boundary conditions, etc., should be reviewed.

- *Strength assessment*

In the modeling process, several assumptions are made which may or may not be conservative. An assessment of the conservatism should be made particularly with regard to the underlying assumptions implicit in the design criteria that are being applied.

In making an assessment of the buckling strength of a structural component based on the results of an FEM analysis, appropriate allowances should also be made for factors that were not included or fully considered.

- *Accuracy assessment*

In assessing the accuracy of the results, factors to be considered include model complexity and behavior, mesh refinement, and solution options, etc. In reducing the model's complexity, the analysts would necessarily have omitted some elements of the structure. The effect of these factors on the results should be assessed. The limitations of the element types used should also be assessed with respect to their capacity to model the required behavior.