

# Building Comfort Solutions

Variable Refrigerant Flow Zoning Systems



***R2-Series***



***Y-Series***



***S-Series***



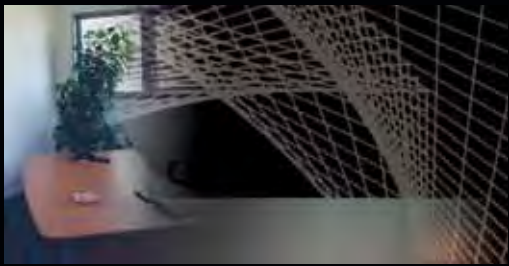
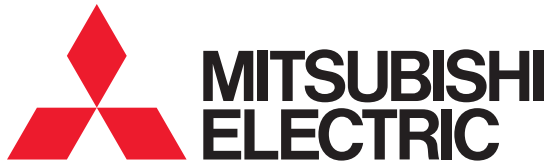

## Table of Contents

Introduction .....	2
Overview of CITY MULTI® .....	4
System Components .....	6
Benefits .....	7
R2-Series Overview .....	8
R2-Series Specifications .....	11
Y-Series Overview .....	14
Y-Series Specifications .....	17
S-Series Overview .....	18
S-Series Specifications .....	19
Indoor Unit Overview .....	20
PKFY Indoor Unit .....	22
PLFY Indoor Unit .....	24
PMFY Indoor Unit .....	26
PCFY Indoor Unit .....	28
PDFY/PEFY Indoor Unit .....	30
PFFY Indoor Unit .....	34
Controls Network Overview .....	36
Controls Network Specifications .....	37
Controllers .....	38
G-50A/GB-50A Centralized Controllers ..	40
TG-2000™ Integrated System Software ..	41
System Integration:	
LonWorks® and BACnet® .....	42
Lossnay® ERVs .....	43

Mitsubishi Electric is a world leader in all types of quality products. Consumer products like high-definition televisions and home theater systems have won awards for innovation and quality.

Semi-conductors, opto-electronics devices, communication products, power generation systems, and, of course, heating and air-conditioning systems are all part of the global Mitsubishi Electric family.





Quality describes the products engineered and manufactured by Mitsubishi Electric. Quality is what comes to mind when we think of Mitsubishi televisions, elevators, and air-handling systems -- quality that comes from the fact that the majority of components found in Mitsubishi Electric products are made by Mitsubishi Electric factories. Quality comes from a company that controls its own research, development, design, materials, and manufacturing. From beginning to end, it's all Mitsubishi Electric engineering; it's all about quality.

The technological advances developed by Mitsubishi Electric show up as innovative features throughout all of Mitsubishi Electric's products. Efficient and technologically advanced motors, controls, INVERTER-driven compressors, linear electronic expansion valves, and micro-processors are all developed by Mitsubishi Electric and used in the CITY MULTI® Variable Refrigerant Flow Zoning (VRFZ) systems. Cross-functional engineering allows Mitsubishi Electric to provide innovative new products in the United States that have a proven track record worldwide.



## Individual Air Conditioning and Heating

Mitsubishi Electric's line of CITY MULTI and Mr. Slim® air conditioning and heating products are intelligent systems, helping improve quality of life. Developed for commercial or residential use, these products take advantage of Mitsubishi Electric's innovative engineering and world-recognized quality.



# CITY MULTI® VRFZ (Variable Refrigerant Flow Zoning) Systems: a user-friendly, ductless, or ducted **commercial** or **residential** comfort control system.

Quality and reliability from a name you know: Mitsubishi Electric

CITY MULTI is the first two-pipe, simultaneous cooling and heating system available in the United States. Yet our technology has a long, proven track record of quality and reliability around the world. Mitsubishi Electric, an acknowledged global industry leader, has installed CITY MULTI zoning systems in buildings throughout Asia, Europe, and elsewhere for nearly twenty years with great success and customer satisfaction. Let a Mitsubishi Electric representative show you how you can put the ultimate cooling and heating system to work for you and your customers right here, right now. Contact us at 800-433-4822 (#4).

## Zoning advantage

The best way to ensure total comfort for the occupants of offices, schools, hospitals, assisted-living facilities, hotels, and more is to provide each individual zone with a personalized comfort system. Zoning offers maximum individual comfort and energy savings because only the zones that need air conditioning receive it. Each zone of the CITY MULTI system has its own indoor unit or group of indoor units that precisely control the indoor temperature while operating with optimum energy usage. You set the comfort level, then relax.

The CITY MULTI VRFZ (Variable Refrigerant Flow Zoning) system takes advantage of inverter technology by varying the speed of the compressor in the outdoor unit to meet the changing load requirements in each of the indoor zones. An energy-wasting “dump zone” for excess hot or cold air as used with a typical zoning system is not necessary with CITY MULTI systems. Our system recycles the energy in other zones to provide comfort only to the zones calling for air conditioning.

## Complete zoning system

A CITY MULTI VRFZ system consists of an outdoor unit, a branch circuit (BC) Controller (depending on series), multiple indoor units, and corresponding system and zone controllers.

Installation of this fully integrated zoning system is fairly simple. The outdoor unit, the BC Controller, and each of the indoor units are connected by a two-pipe refrigerant system. The outdoor unit and the BC Controller, depending on the series, work in unison to deliver a variation of refrigerant flow to each indoor unit. The Direct Digital Controls system controls the network link between the indoor units with the BC Controller and the outdoor unit to provide convenient control of the entire system. Separate remote controllers connected to individual indoor units — or groups of indoor units — provide individual zone control.

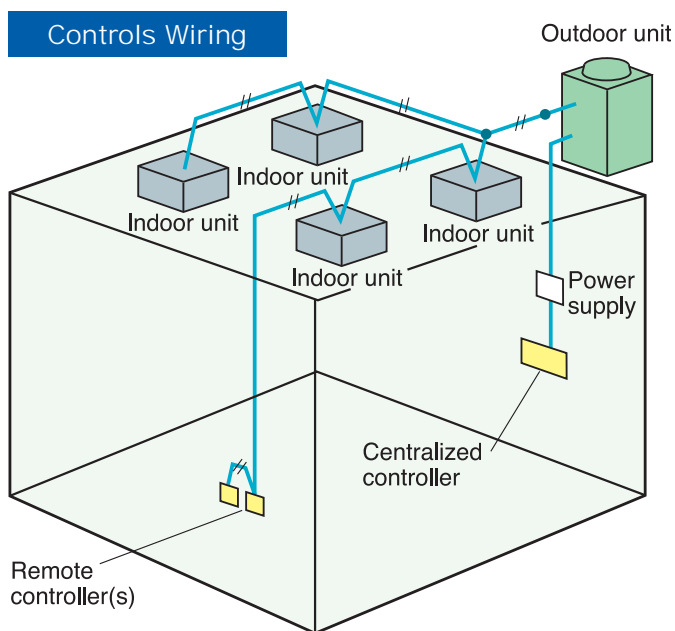

These controllers provide a wide variety of configuration settings to satisfy each zone's requirements, including temperature control and timer settings.

## Easy to install, easier to operate

CITY MULTI is a simple, two-pipe system with easy, non-polar, two-wire control connections. These features add up to less labor and materials, quicker, easier installation, and a much lower overall operating cost for the building owner.

Ductless or ducted indoor units for ultimate flexibility

CITY MULTI outdoor units can operate up to 32 ductless or ducted indoor units, making the system ideal for virtually any type of application or any variety of applications within the same building. Do you need air conditioning only on demand in a conference room? CITY MULTI provides that. Do you need a centralized system to cool or heat a large working area all day long? CITY MULTI does that. Do you want precise temperature control in a confined zone like a server room with no room for ductwork? CITY MULTI accommodates for this need as well. CITY MULTI works for almost any building that requires a diversified climate-control system.

CITY MULTI VRFZ systems provide virtually everything desired in an air-conditioning system. Direct Digital Controls (DDC) ensure optimized operation of the system. Mitsubishi Electric's inverter technology and electronic expansion valves vary the capacity of the system to match the indoor space load requirements. This feature saves energy and provides ultimate indoor comfort. Up to 32 indoor units can be employed with capacities that connect up to 150% of the outdoor unit's rated capacity. The variable-capacity capability of the indoor units removes any worry that the system could be oversized, a situation that contributes to moisture problems in a building.

So quiet you'll hardly notice it's there

CITY MULTI is designed to provide the quietest possible operation for both indoor and outdoor environments. Indoor units operate as low as 24 dB(A), and outdoor units operate as low as 50 dB(A). That's a major benefit, especially for hospitals, other healthcare facilities, schools, and libraries. CITY MULTI dependably provides comfortable cooling and heating all year long.

## CITY MULTI® offers three series of VRFZ Systems...

### Featuring:

- *Highly efficient inverter technology yields precise temperature control*
- *Zoning system with individual control yields a more comfortable environment by placing the control in the hands of the zone occupants*
- *Two-pipe, two-wire system is easy to install and easy to operate*

### The R2-Series *Simultaneous cooling and heating (3-PHASE)*

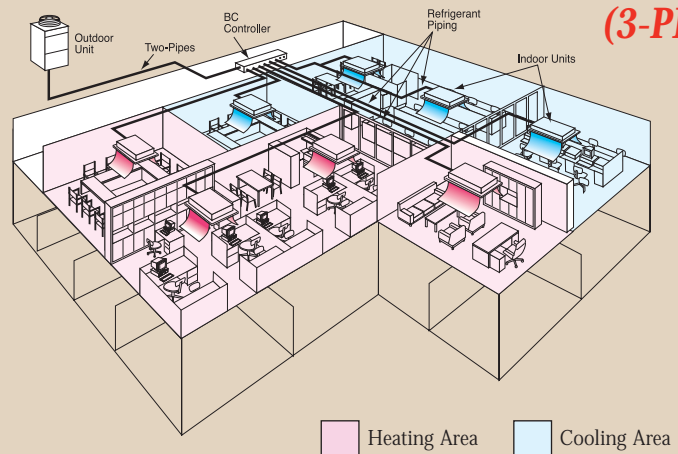

### The Y-Series *Heat Pump (3-PHASE)*

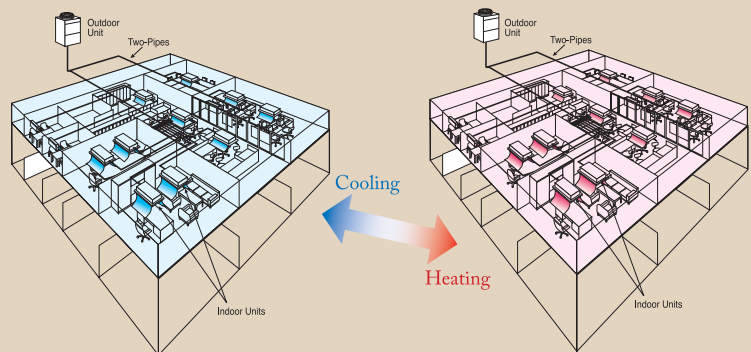

### The S-Series *Heat Pump (1-PHASE)*





# CITY MULTI® System Components

## OUTDOOR UNITS

These compact and powerful R410A outdoor units have one of the smallest VRFZ footprints in the industry and are available in a variety of sizes. Starting at 48,000 Btu/h for the S-Series, there are also ten sizes available for both the R2 and Y-Series, ranging from 72,000 to 234,000 Btu/h. Available in 208/230 volts, three-phase, 60 Hertz, the R410A outdoor units use Mitsubishi Electric's INVERTER-driven scroll compressor that is backed by a six-year limited warranty. This reliable compressor is designed and built by Mitsubishi Electric.

### R2-SERIES Superior Simultaneous Cooling and Heating

The CITY MULTI R2-Series is a simultaneous cooling and heating outdoor unit, which uses BC Controllers to connect up to 32 indoor units to provide energy-saving heat-recovery operation.

#### BC Controller

The BC Controller is a key component used in unison with the R2-Series outdoor unit to provide simultaneous cooling and heating. It redirects refrigerant away from the outdoor coil to be shared by various indoor coils. This unique function transfers heat energy that is otherwise wasted from zones calling for cooling to other zones that call for heating. This capability means less work is required of the outdoor unit, which saves energy and can increase overall capacity. Your choice of BC Controller(s) is based on the number of corresponding indoor units and installation needs.

### Y-SERIES Powerful Heat Pump

The CITY MULTI Y-Series is an outdoor unit flexible enough to cool or heat up to 32 individual zones to maximize your design options. Individual controls for each zone contribute to personalized comfort.

### S-SERIES Powerful 1-PHASE Heat Pump

The CITY MULTI S-Series is a single-phase system perfect for light commercial applications or an entire house with up to eight individual zones per system.



## INDOOR UNITS



Wall-mounted  
PKFY

Ceiling-recessed  
Cassette  
PLFY (4-Way)

Ceiling-recessed  
Cassette  
PMFY (1-Way)

Ceiling-suspended  
PCFY

Ceiling-concealed  
Ducted  
PDFY, PEFY

Floor-standing Exposed  
PFFY-NEMU

Floor-standing Concealed  
PFFY-NRMU

## CONTROLS NETWORK



Remote Controllers  
PAR-21MAA  
PAR-F27MEA

Simple Remote  
PAC-YT51CRB

Schedule Timer  
PAC-YT34STA

On/Off Controller  
PAC-YT40ANRA

G-50A  
Centralized Controllers

GB-50A

CITY MULTI Controls Network (CMCN) uses Mitsubishi Electric's advanced M-NET controls network

Mitsubishi Electric's reliable high-speed communication bus, M-NET, allows data to flow in large capacities to ensure optimized performance of the system. Each component is integrated on the M-NET for precise control of the temperature by regulating the output of the outdoor unit capacity to match the needs of each comfort zone.

Mitsubishi Electric's selection of multiple different styles of indoor units allows you to choose the models and sizes that will meet your requirements for indoor unit layout and design.

## Zoning advantage

Zones are actively cooled in one zone while heating another. Set up zones to maximize simultaneous operation: interior/exterior, eastern exposure/western exposure. Each zone gets the cooling or heating that is needed at any time. Simultaneous cooling and heating over two-pipes provides air conditioning and control flexibility to each and every zone.

## Comfort control

CITY MULTI delivers precise individual comfort. Regardless of time of day, sun or shade, season of the year, or special room requirements, CITY MULTI provides control of comfort. You place the personalized comfort at your fingertips.

## Quiet operation

CITY MULTI is designed for the quietest possible operation both indoors and out. Outdoor units are as quiet as 50 dB(A) and indoor units as low as 24 dB(A). That's a huge advantage, especially for classrooms, schools, universities, hospitals, other healthcare facilities, and libraries, where quiet conversations are paramount.



## Reliable operation

CITY MULTI VRFZ systems have been operating worldwide for 20-plus years virtually worry-free due to the quality of Mitsubishi Electric engineering. Our advanced yet simple-to-use analytical tools in the hands of our well-trained service team keep the systems running smoothly. The scroll compressor's six-year limited warranty is an added benefit.

## Design flexibility

CITY MULTI VRFZ systems provide engineers the flexibility to meet their application designs ranging from the simple to the complex. Each CITY MULTI R2 and Y-Series system can be configured for up to 32 zones within a building. The S-Series system can be configured for up to 8 zones. Multiple CITY MULTI systems can be integrated into our controls network to air-condition and manage up to 2,000 zones from a single networked computer using Mitsubishi Electric furnished software.

## Mitsubishi's INVERTER advantage

CITY MULTI's inverter technology is highly responsive and efficient. By varying the capacity of the system to match your indoor space load requirements while responding to outdoor conditions, CITY MULTI provides the ultimate in precise indoor comfort control plus great energy savings.

## Advanced zone control

The CITY MULTI Controls Network (CMCN) utilizes Mitsubishi Electric's advanced M-NET technology to provide individual, personalized comfort and powerful, centralized control. Each component is integrated onto the secure high-speed communication bus to provide precise temperature control by varying the output of the outdoor unit(s) to match the needs of each zone.



# CITY MULTI® R2-Series: The First Two-pipe System that Simultaneously Cools and Heats.

The CITY MULTI R2-Series offers the ultimate in freedom and flexibility. Cool one zone while heating another. Set up zones to maximize simultaneous operation: interior/exterior or eastern exposure/western exposure. Each zone gets the cooling or heating that's needed at any time.

CITY MULTI R2-Series Variable Refrigerant Flow Zoning (VRFZ) system from Mitsubishi Electric's HVAC Advanced Products Division offers you the ultimate in enhanced comfort and effective energy usage. Mitsubishi Electric's CITY MULTI R2-Series outdoor unit uses INVERTER-driven compressor (Variable Frequency Drive) technology to provide highly responsive cooling and heating performance. By responding to indoor and outdoor temperature fluctuations, the system varies power consumption by adjusting the compressor speed to optimize energy usage. The variable-capacity indoor units are controlled by electronic expansion valves. This feature allows operation only at the levels required to maintain a consistently comfortable indoor environment without wasting energy.

### Simultaneous operation

CITY MULTI systems provide simultaneous cooling and heating operation in fall, winter, and spring when the temperature drops below 65°F. So there is a significant number of days when the CITY MULTI R2-Series takes advantage of simultaneous operation, while maximizing comfort. This innovation results in virtually no energy wasted by being expelled outdoors. This special function results in optimum energy usage.



### Year-round energy savings

CITY MULTI R2-Series VRFZ systems provide continuous energy savings. During warm weather the CITY MULTI R2-Series VRFZ Systems will deliver the precise amount of cooling to the zones requiring cooling. During cold weather, R2-Series VRFZ System provides outstanding heating performance because of the high-speed capabilities of the INVERTER-driven compressor in the outdoor unit.

Most of the year, CITY MULTI R2-Series VRFZ systems operate in partial-load conditions, and the INVERTER-driven compressor runs only at the speeds necessary to provide the required amount of cooling and heating.

Using the same refrigerant circuit, the system provides true zoning configuration by heating one or more zones, while simultaneously cooling one or more additional zones.





# R2-SERIES OVERVIEW

## Effective energy usage

The total *applied* capacity of the CITY MULTI R2-Series VRFZ System's indoor units can be up to 150% of the capacity of the outdoor unit by taking advantage of load diversity and simultaneous cooling/heating operation. CITY MULTI VRFZ Systems are able to satisfy a significantly higher building load by efficiently distributing the capacity to the outdoor unit and indoor units while using much less energy.

## R2-Series capacities

Model Name	Btu/h	No. of Connectable Indoor Units	Capacity of Connectable Indoor Units
PURY-P72TGMU	72,000	up to 15	36,000 – 108,000 Btu/h
PURY-P96TGMU	96,000	up to 19	48,000 – 144,000 Btu/h
PURY-PI08TGMU	108,000	up to 20	54,000 – 162,000 Btu/h
PURY-PI26TGMU	126,000	up to 20	63,000 – 189,000 Btu/h
PURY-PI44TGMU	144,000	up to 24	72,000 – 216,000 Btu/h
PURY-PI68TGMU	168,000	up to 24	84,000 – 252,000 Btu/h
PURY-PI92TGMU	192,000	up to 24	96,000 – 288,000 Btu/h
PURY-P204TGMU	204,000	up to 24	102,000 – 306,000 Btu/h
PURY-P216TGMU	216,000	up to 32	108,000 – 324,000 Btu/h
PURY-P234TGMU	234,000	up to 32	117,000 – 351,000 Btu/h

## Features

*On-demand simultaneous cooling and heating*

*Quiet operation*

*Easy installation*

*Ductless or ducted*

## Benefits

Enhanced comfort and energy savings. Each zone, regardless of sun exposure or utilization, will remain truly comfortable.

Perfect for sound-sensitive applications like hotel rooms, schools, and libraries, where a quiet conversation is paramount.

Little or no ductwork, simple controls, and two-pipe configuration mean less labor and materials used and a fast track to personalized comfort.

Versatile locations and applications for indoor units.



*CITY MULTI R2-Series uses BC Controller(s) and indoor units to simultaneously cool and heat different zones in the same building.*

SIMULTANEOUS  
COOLING AND HEATING

# R2-Series

Outdoor Unit and BC Controller(s)  
Connect Up to 32 Indoor Units.



**R2-Series Outdoor Unit**

Simultaneous cooling and heating two-pipe system with inverter technology

CITY MULTI from Mitsubishi Electric delivers precisely the cooling and heating needed at any time. How? Our INVERTER-driven compressor technology and our exclusive BC Controller make two-pipe simultaneous cooling and heating possible. As indoor and outdoor temperatures fluctuate, the system automatically

adjusts the compressor speed to react immediately and deliver the exact amount of refrigerant — no more, no less — thereby maintaining a comfortable interior environment while saving energy.

### Small footprint

At 39" x 33" CITY MULTI R2-Series outdoor units offer one of the smallest footprints in the industry for a 108,000 Btu/h outdoor unit. An added advantage is the vertical-discharge design, which allows outdoor units to be installed side-by-side in a single area, saving space and resources when multiple units are involved.

#### In-line installation of outdoor units

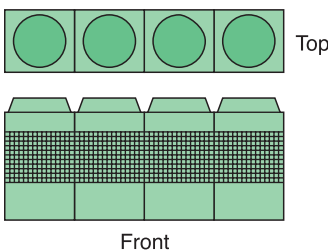

#### Installation footprint including service space

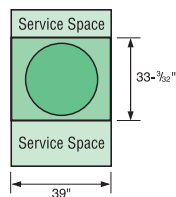

### Outdoor unit service information for easy diagnostics

The outdoor unit's four-digit display speeds up the service process by providing a fault code and history. It also allows over 250 items of operation information to be displayed.



### BC Controller

In many ways, the BC Controller is the technological heart of the CITY MULTI R2-Series. It works in unison with the outdoor unit to provide simultaneous cooling and heating, something no other two-pipe system can do.

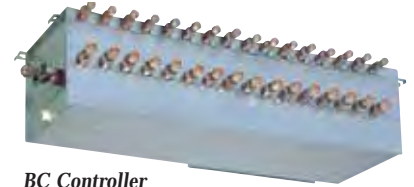

**BC Controller**

#### The Single BC

Controller is connected to the outdoor unit

by two pipes and to each indoor unit by a series of two refrigerant pipes, depending on the indoor unit count. The

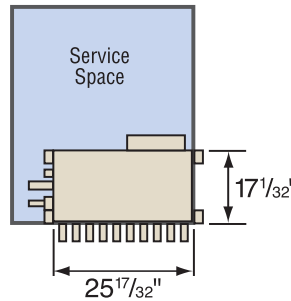

Main BC Controller and up to two optional Sub BC Controllers connect the outdoor unit to the system's indoor units. The BC Controller is required for all CITY MULTI R2-Series installations. The BC Controller model and size you select depends on how many indoor units will be

operated from each outdoor unit, your total capacity requirements, and your installation needs. Each set of ports supports up to 54,000 Btu/h of capacity per indoor unit.

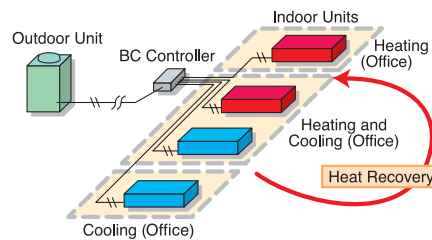

### Two-pipe VRFZ System

The R2-Series system offers flexibility and reduced costs for refrigerant piping. The system may have a total combined length of refrigerant piping up to 1,312 feet one way.

#### Refrigerant Piping Lengths

#### Maximum Feet

Total length.....	984-1,312*
Maximum allowable length.....	492 (574 equivalent)
Maximum length between outdoor and single/main BC Controller.....	360

#### Vertical differentials between units

Indoor/outdoor (outdoor higher) .....	164
Indoor/outdoor (outdoor lower) .....	131
Indoor/BC Controller (single/main) .....	49
Indoor/indoor .....	49
Main BC Controller/Sub BC Controller .....	49

\*Maximum total length is dependent upon the distance between the outdoor unit and the Single/Main BC Controller.

# R2-SERIES SPECIFICATIONS



## PURY-P-TGMU(-BS) Specifications

Model Name			PURY-P72TGMU-A(-BS)	PURY-P96TGMU-A(-BS)	PURY-P108TGMU-A(-BS)	PURY-P126TGMU-A(-BS)	PURY-P144TGMU-A(-BS)
Power Source			208/230V, 3-phase, 60Hz				
Capacity *1	Cooling	Btu/h	72,000	96,000	108,000	126,000	144,000
	Heating	Btu/h	80,000	108,000	120,000	140,000	160,000
Power Input	Cooling	kW	6.48	8.67	9.73	11.36	14.2
	Heating	kW	6.33	8.56	9.92	11.67	13.67
Current (208/230V)	Cooling	A	19.9/18.0	26.7/24.1	30.0/27.1	35.0/31.6	43.8/39.6
	Heating	A	19.5/17.6	26.4/23.8	30.6/27.6	36.0/32.5	42.1/38.1
Fan	Type x Quantity		Propeller fan x 1	Propeller fan x 1	Propeller fan x 1	Propeller fan x 1	Propeller fan x 1
	Airflow Rate	CFM	7,050	7,050	7,050	8,450	8,450
	Motor Output	kW	0.38 x 1	0.38 x 1	0.38 x 1	0.64 x 1	0.64 x 1
Compressor	Type		Inverter-driven scroll hermetic				
	Motor Output	kW	4.7	6.7	8	8.5	9.7
	Crankcase Heater	W	57(230V)	57(230V)	57(230V)	57(230V)	57(230V)
Refrigerant	Lubricant		MEL32				
	Type		R410A				
External Finish			Pre-coated galvanized sheets (plus powder coating for -BS types) <Munsell 5Y 8/1 or similar>				
Dimensions	Height	Inches	72-15/32	72-15/32	72-15/32	72-15/32	72-15/32
	Width	Inches	39	39	39	50-13/16	50-13/16
	Depth	Inches	33-3/32	33-3/32	33-3/32	33-3/32	33-3/32
Net Weight		Pounds	536	574	574	672	672
Sound Level (as measured in anechoic room)		dB(A)	56	57	60	61	61
Protection Devices	High Pressure Protection		High pressure sensor, High pressure switch				
	Compressor/Fan Inverter		Overheat protection/Thermal switch				
			Overcurrent and overheat protection				
Refrigerant Pipe Dimensions	Low Pressure	Inches	3/4 (Brazed)	7/8 (Brazed)	7/8 (Brazed)	1-1/8 (Brazed)	1-1/8 (Brazed)
	High Pressure	Inches	5/8 (Brazed & Flare)	3/4 (Brazed & Flare)	3/4 (Brazed & Flare)	3/4 (Brazed)	7/8 (Brazed)
Indoor Unit	Total Capacity		50-150% of Outdoor Unit Capacity				
	Quantity		P06-P96/1-15	P06-P96/1-19	P06-P96/1-20	P06-P96/1-20	P06-P96/1-24
Operating Temperature Range	Cooling		Outdoor: 23°F DB to 109°F DB (32°F DB to 109°F DB if outdoor unit is lower than indoor unit)				
	Heating		Outdoor: -4°F WB to 60°F WB				

Model Name			PURY-P168TGMU-A(-BS)	PURY-P192TGMU-A(-BS)	PURY-P204TGMU-A(-BS)	PURY-P216TGMU-A(-BS)	PURY-P234TGMU-A(-BS)
Power Source			208/230V, 3-phase, 60Hz				
Capacity *1	Cooling	Btu/h	168,000	192,000	204,000	216,000	234,000
	Heating	Btu/h	188,000	216,000	228,000	248,000	268,000
Power Input	Cooling	kW	14.97	17.34	18.71	19.92	21.62
	Heating	kW	15.02	17.48	18.65	21.03	23.11
Current (208/230V)	Cooling	A	46.1/41.7	53.4/48.3	57.7/52.1	61.4/55.5	66.6/60.3
	Heating	A	46.3/41.9	53.9/48.7	57.5/50.0	64.8/58.6	71.2/64.4
Fan	Type x Quantity		Propeller fan x 2	Propeller fan x 2	Propeller fan x 2	Propeller fan x 2	Propeller fan x 2
	Airflow Rate	CFM	14,100	14,100	14,100	14,100	14,100
	Motor Output	kW	0.38 x 2	0.38 x 2	0.38 x 2	0.38 x 2	0.38 x 2
Compressor	Type		Inverter-driven scroll hermetic and scroll hermetic				
	Motor Output	kW	6.8 + 5.3	8.2 + 5.3	9.3 + 5.3	10.1 + 5.3	10.9 + 5.3
	Crankcase Heater	W	57 x 2(230V)	57 x 2(230V)	57 x 2(230V)	57 x 2(230V)	57 x 2(230V)
	Lubricant		MEL32				
Refrigerant	Type		R410A				
External Finish			Pre-coated galvanized sheets (plus powder coating for -BS types) <Munsell 5Y 8/1 or similar>				
Dimensions	Height	Inches	72-15/32	72-15/32	72-15/32	72-15/32	72-15/32
	Width	Inches	78-3/8	78-3/8	78-3/8	78-3/8	78-3/8
	Depth	Inches	33-3/32	33-3/32	33-3/32	33-3/32	33-3/32
Net Weight		Pounds	1,090	1,090	1,090	1,090	1,090
Sound Level (as measured in anechoic room)		dB(A)	61	62	62	62.5	63
Protection Devices	High Pressure Protection		High pressure sensor, High pressure switch				
	Compressor/Fan Inverter		Overheat protection/Thermal switch				
			Overcurrent and overheat protection				
Refrigerant Pipe Dimensions	Low Pressure	Inches	1-1/8 (Brazed)	1-1/8 (Brazed)	1-1/8 (Brazed)	1-1/8 (Brazed)	1-1/8 (Brazed)
	High Pressure	Inches	7/8 (Brazed)	7/8 (Brazed)	1-1/8 (Brazed)	1-1/8 (Brazed)	1-1/8 (Brazed)
Indoor Unit	Total Capacity		50-150% of Outdoor Unit Capacity				
	Quantity		P06-P96/1-24	P06-P96/1-24	P06-P96/1-24	P06-P96/1-32	P06-P96/1-32
Operating Temperature Range	Cooling		Outdoor: 23°F DB to 109°F DB (32°F DB to 109°F DB if outdoor unit is lower than indoor unit)				
	Heating		Outdoor: -4°F WB to 60°F WB				

**Note: Rating Conditions**

\*1 Cooling: Indoor: 80°F (27°C) DB / 67°F (19°C) WB; Outdoor: 95°F (35°C) DB  
Heating: Indoor: 70°F (21°C) DB; Outdoor: 47°F (8°C) DB / 43°F (6°C) WB

-BS indicates seacoast protection option.

Specifications are subject to change.



# BC CONTROLLER SPECIFICATIONS

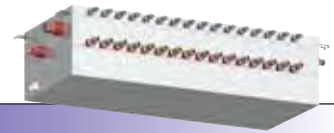

CMB-P-NU-G (Single BC) Specifications								
Model Name			CMB-P105NU-G	CMB-P106NU-G	CMB-P108NU-G	CMB-P1010NU-G	CMB-P1013NU-G	CMB-P1016NU-G
Number of Branches			5	6	8	10	13	16
Power Source			208/230V, 1-phase, 60 Hz					
Power Input	Cooling	W	73	86	112	138	178	217
	Heating	W	33	40	53	66	86	106
Current (208/230V)	Cooling	A	0.35/0.32	0.41/0.37	0.54/0.49	0.66/0.60	0.86/0.77	1.04/0.94
	Heating	A	0.16/0.14	0.19/0.17	0.25/0.23	0.32/0.29	0.41/0.37	0.51/0.46
External Finish			Unit: Galvanized steel plate; Drain pan: Pre-coated galvanized sheets plus powder coating					
Dimensions	Height	Inches	11-3/16	11-3/16	11-3/16	11-3/16	11-3/16	11-3/16
	Width	Inches	25-17/32	25-17/32	25-17/32	25-17/32	43-1/4	43-1/4
	Depth	Inches	17-1/32	17-1/32	17-1/32	17-1/32	17-1/32	17-1/32
Net Weight		Pounds	72	76	84	94	126	138
Connectable Outdoor Unit			PURY-P72/P96/P108/P126TGMU-A(-BS)					
Refrigerant Pipe Dimensions	To Outdoor Unit PURY-P72	Low Pressure (in.)	3/4 (Brazed)					
		High Pressure (in.)	5/8 (Brazed)					
	To Outdoor Unit PURY-P96/P108	Low Pressure (in.)	7/8 (Brazed)					
		High Pressure (in.)	3/4 (Brazed)					
	To Outdoor Unit PURY-P126	Low Pressure (in.)	1-1/8 (Brazed)					
		High Pressure (in.)	3/4 (Brazed)					
	To Indoor Unit	Gas (in.)	5/8 (Flare)					
		Liquid (in.)	3/8 (Flare)					
Indoor Unit Capacity Connectable to One Branch			54,000 Btu/h or less per branch					
Drainpipe			O.D. 1-1/4"					

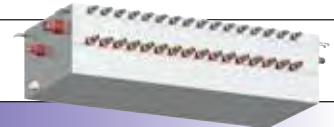

CMB-P-NU-GA (Main BC) Specifications								
Model Name			CMB-P108NU-GA	CMB-P1010NU-GA	CMB-P1013NU-GA	CMB-P1016NU-GA		
Number of Branches			8	10	13	16		
Power Source			208/230V, 1-phase, 60 Hz					
Power Input	Cooling	W	112	138	178	217		
	Heating	W	53	66	86	106		
Current (208/230V)	Cooling	A	0.54/0.49	0.66/0.60	0.86/0.77	1.04/0.94		
	Heating	A	0.25/0.23	0.32/0.29	0.41/0.37	0.51/0.46		
External Finish			Unit: Galvanized steel plate; Drain pan: Pre-coated galvanized sheets plus powder coating					
Dimensions	Height	Inches	11-13/32	11-13/32	11-13/32	11-13/32		
	Width	Inches	43-23/32	43-23/32	43-23/32	43-23/32		
	Depth	Inches	20-1/2	20-1/2	20-1/2	20-1/2		
Net Weight		Pounds	122	132	148	162		
Connectable Outdoor Unit			PURY-P72/P96/P108/P126/P144/P168/P192/P204/P216/P234TGMU-A(-BS)					
Refrigerant Pipe Dimensions	To Outdoor Unit PURY-P72	Low Pressure (in.)	3/4 (Brazed)					
		High Pressure (in.)	5/8 (Brazed)					
	To Outdoor Unit PURY-P96/P108	Low Pressure (in.)	7/8 (Brazed)					
		High Pressure (in.)	3/4 (Brazed)					
	To Outdoor Unit PURY-P126	Low Pressure (in.)	1-1/8 (Brazed)					
		High Pressure (in.)	3/4 (Brazed)					
	To Outdoor Unit PURY-P144/P168/P192	Low Pressure (in.)	1-1/8 (Brazed)					
		High Pressure (in.)	7/8 (Brazed)					
	To Outdoor Unit PURY-P204/P216/P234	Low Pressure (in.)	1-1/8 (Brazed)					
		High Pressure (in.)	1-1/8 (Brazed)					
	To Indoor Unit	Gas (in.)	5/8 (Flare)					
		Liquid (in.)	3/8 (Flare)					
	To other BC Controller (Total indoor unit capacity connected to this Sub BC ≤ 72,000 btu/h)	Low Pressure (in.)	3/4 (Brazed)					
		High Pressure (in.)	5/8 (Brazed)					
Liquid (in.)		3/8 (Brazed)						
To other BC Controller (Total indoor unit capacity connected to this Sub BC between 73,000-108,000 btu/h)	Low Pressure (in.)	7/8 (Brazed)						
	High Pressure (in.)	3/4 (Brazed)						
	Liquid (in.)	3/8 (Brazed)						
To other BC Controller (Total indoor unit capacity connected to this Sub BC between 109,000-128,000 btu/h)	Low Pressure (in.)	1-1/8 (Brazed)						
	High Pressure (in.)	3/4 (Brazed)						
	Liquid (in.)	1/2 (Brazed)						
Indoor Unit Capacity Connectable to One Branch			54,000 Btu/h or less per branch					
Drainpipe			O.D. 1-1/4"					

Specifications are subject to change.

# BC CONTROLLER SPECIFICATIONS



CMB-P-NU-GB (Sub BC) Specifications					
Model Name		CMB-P104NU-GB		CMB-P108NU-GB	
Number of Branches		4		8	
Power Source		208/230V, 1-phase, 60 Hz			
Power Input	Cooling	W	53	106	
	Heating	W	27	53	
Current (208/230V)	Cooling	A	0.25/0.23	0.51/0.46	
	Heating	A	0.13/0.12	0.25/0.23	
External Finish		Unit: Galvanized steel plate; Drain pan: Pre-coated galvanized sheets plus powder coating			
Dimensions	Height	Inches	11-3/16		
	Width	Inches	25-17/32		
	Depth	Inches	17-1/32		
Net Weight		Pounds	62	82	
Refrigerant Pipe Dimensions	To Indoor Unit	Gas (in.)	5/8 (Flare)		
		Liquid (in.)	3/8 (Flare)		
	From other BC controller (Total indoor unit capacity connected to this Sub BC ≤ 72,000 btu/h)	Low Pressure (in.)	3/4 (Brazed)		
		High Pressure (in.)	5/8 (Brazed)		
		Liquid (in.)	3/8 (Brazed)		
	From other BC controller (Total indoor unit capacity connected to this Sub BC between 73,000-108,000 btu/h)	Low Pressure (in.)	7/8 (Brazed)		
		High Pressure (in.)	3/4 (Brazed)		
		Liquid (in.)	3/8 (Brazed)		
	From other BC controller (Total indoor unit capacity connected to this Sub BC between 109,000-126,000 btu/h)	Low Pressure (in.)	1-1/8 (Brazed)		
		High Pressure (in.)	3/4 (Brazed)		
		Liquid (in.)	1/2 (Brazed)		
	Indoor Unit Capacity Connectable to One Branch		54,000 Btu/h or less per branch		
Drainpipe		O.D. 1-1/4"			

Specifications are subject to change.

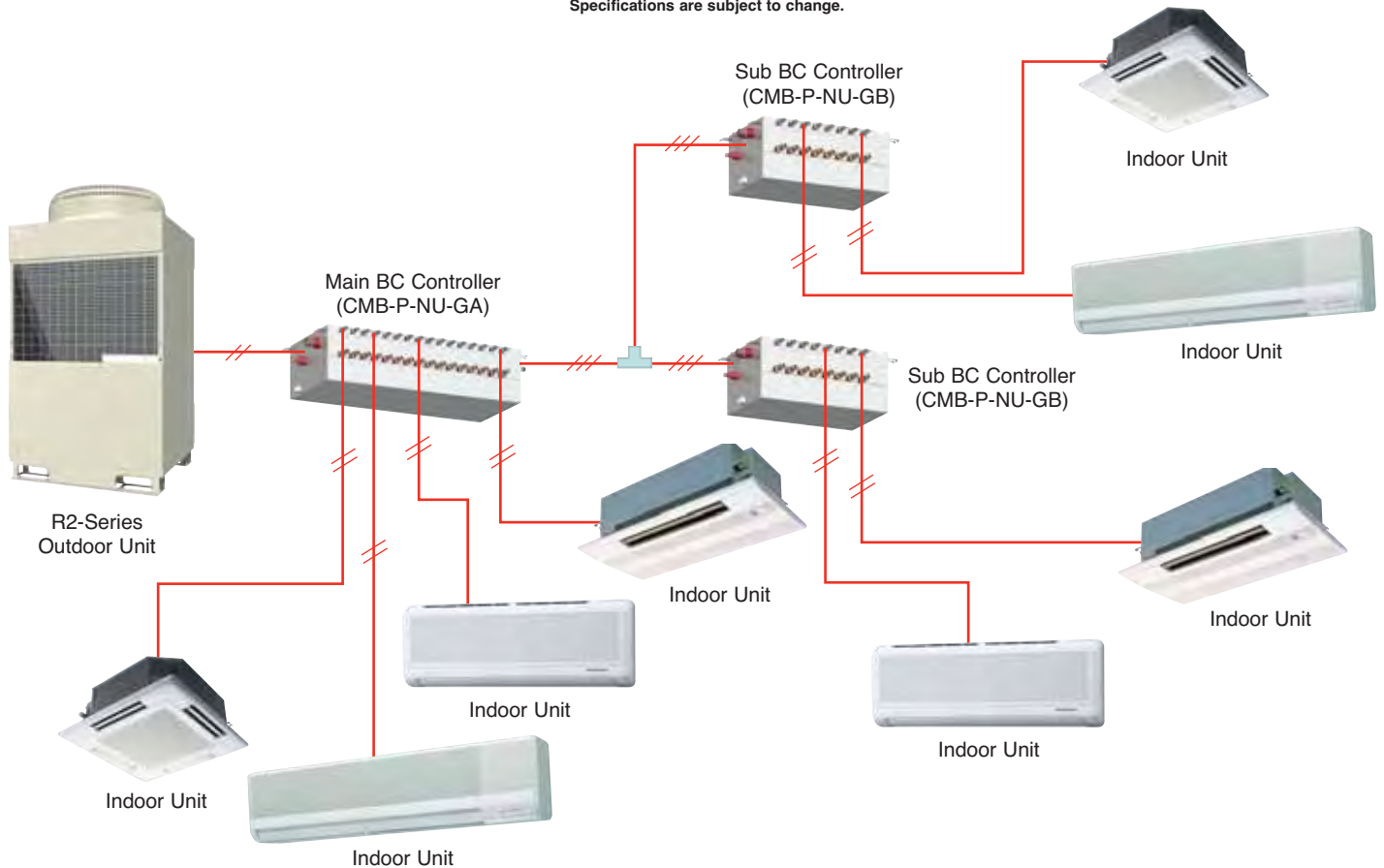

## CITY MULTI® Y-Series: The Two-pipe Zoned System

designed for

# Heat Pump Operation.

### Design flexibility

Flexibility is the key with the CITY MULTI Y-Series. The Y-Series, just like the R2-Series, can air-condition up to 32 zones intelligently. The Y-Series takes advantage of Mitsubishi Electric's inverter technology to provide the precise amount of cooling or heating to each and every zone. By utilizing T-branches and headers, the Y-Series provides the ultimate in piping design flexibility that is truly simple in application.

### The *ultimate in zoning*: just the way you imagined

The CITY MULTI Y-Series uses a two-pipe system with a wide variety of indoor units and individual zone controllers to provide the ultimate zoning system. Headers and T-branches simplify the piping design and provide design freedom for placement of both piping and indoor units. The BC Controller is not required for Y-Series installations. Individual zones can be managed by remote controllers placed in each zone and by the G-50A/GB-50A centralized controller.

### Intelligent energy usage

The highly responsive INVERTER technology and customized individual zones of the CITY MULTI Y-Series provide year-round savings. In the warm summer, the Y-Series provides exceptional zoned cooling, and in the cold winter months the INVERTER-driven compressor provides outstanding heating performance.

CITY MULTI systems in combination with Mitsubishi Electric's TG-2000 integrated system software are able to monitor and maintain each zone's energy usage via a network computer.

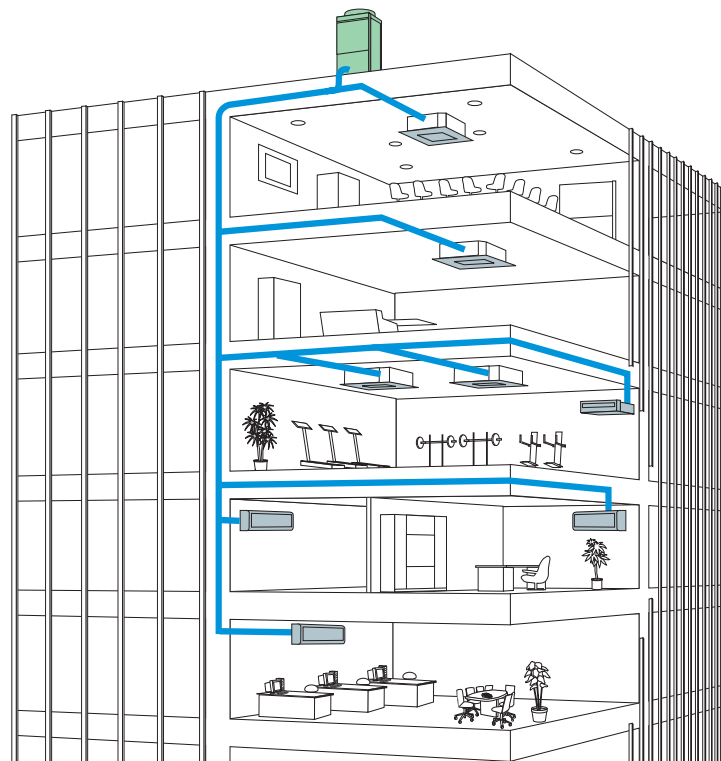

The CITY MULTI Y-Series can provide cooling or heating for up to 32 zones with a total applied capacity of 130% of the outdoor unit's rating.

### Y-Series capacities

Model Name	Btu/h	No. of Connectable Indoor Units	Capacity of Connectable Indoor Units
PUHY-P72TGMU	72,000	up to 13	36,000 – 93,000 Btu/h
PUHY-P96TGMU	96,000	up to 16	48,000 – 124,000 Btu/h
PUHY-PI08TGMU	108,000	up to 19	54,000 – 140,000 Btu/h
PUHY-PI26TGMU	126,000	up to 20	63,000 – 163,000 Btu/h
PUHY-PI44TGMU	144,000	up to 22	72,000 – 187,000 Btu/h
PUHY-PI68TGMU	168,000	up to 24	84,000 – 218,000 Btu/h
PUHY-PI92TGMU	192,000	up to 24	96,000 – 249,000 Btu/h
PUHY-P204TGMU	204,000	up to 24	102,000 – 265,000 Btu/h
PUHY-P216TGMU	216,000	up to 32	108,000 – 280,000 Btu/h
PUHY-P234TGMU	234,000	up to 32	117,000 – 304,000 Btu/h



# Y-SERIES OVERVIEW

## Peace and quiet

All CITY MULTI systems, including the Y-Series, are designed for the quietest possible operation. Y-Series outdoor units are a quiet 56 dB(A), while indoor units are rated as low as 24 dB(A), making them ideal for sound-sensitive applications such as classrooms, guest rooms, and libraries where it's important to have a quiet environment.

With a wide line-up of indoor units in connection with a flexible piping system, the CITY MULTI Y-Series can be configured for all applications. Depending on capacity, up to 32 indoor units can be connected to maximize an engineer's design options. This feature allows easy air conditioning in each area with convenient individual controllers.

The CITY MULTI Y-Series is designed to be your best choice for cooling or heating. The Y-Series provides a true zoning system. It uses INVERTER-driven technology to provide intelligent, quiet, and reliable operation. It is directly coupled with the latest controls and protocols to monitor and operate the individual zones and perform building management.

All of these benefits are accomplished, while delivering the ultimate in comfort and system management.

## CITY MULTI Y-Series: Intelligent two-pipe cooling or heating system

*(Illustration below shows cooling operation.  
Zoning is identical in heating mode.)*



Features	Benefits
<i>Zoned cooling or heating system</i>	An energy-efficient system that provides maximum comfort.
<i>Quiet operation</i>	Perfect for sound-sensitive applications like hotel rooms, schools, and libraries, where a quiet conversation is paramount.
<i>Easy installation</i>	Little or no ductwork, simple controls, and two-pipe configuration mean less labor and materials used and a fast track to personalized comfort.
<i>Ductless or ducted</i>	Versatile locations and applications for indoor units.

# Y-Series

Configure your piping system to fit any layout.



The CITY MULTI Y-Series makes use of a two-pipe refrigerant system, which allows for system change-over from cooling to heating, ensuring that a constant indoor climate is maintained in all zones. The Y-Series can accommodate up to 32 indoor units for each outdoor unit. Y-Series and R2-Series can be used in the

same building to meet the building's design and each tenant's needs ideally. Up to 2,000 indoor units, across R2-Series and Y-Series outdoor units can be managed by multiple G-50A/GB-50A Centralized Controllers and Mitsubishi Electric's TG-2000 integrated system software.

## Smallest Footprint

Just like the R2-Series, the Y-Series has one of the smallest outdoor footprints in the industry at 39" x 33" for a 108,000 Btu/h unit. An added advantage is the top discharge design, which allows outdoor units to be installed side-by-side in a single area, saving space when multiple units are involved. R2-Series and Y-Series outdoor units can be installed side-by-side to deliver the ultimate in air conditioning for a building while providing design flexibility.

**In-line installation of outdoor units**

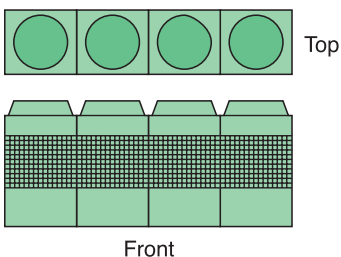

**Installation footprint including service space**

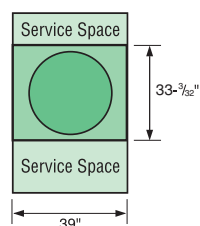

## Two-pipe VRFZ system

The Y-Series two-pipe system offers great piping design flexibility. Two pipes run from the Y-Series outdoor unit to connect up to 32 indoor units via simple T-branches, headers, or combination of both. A Y-Series system may have a total combined length of refrigerant piping up to 984 feet one way. The farthest distance between the Y-Series outdoor unit and any one of the 32 indoor units is 492 feet. The outdoor unit can be placed 164 feet vertically above the lowest indoor unit or 131 feet vertically below the highest indoor unit. The Y-Series offers exceptional line lengths that will accommodate just about any commercial application, including multi-story office buildings,

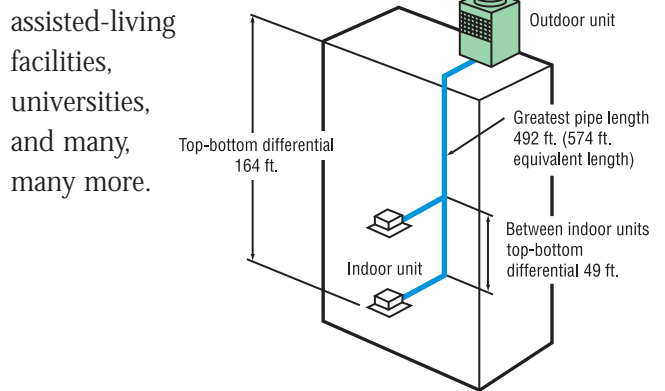

### Refrigerant Piping Lengths      Maximum Feet

Total length	.....	984
Maximum allowable length	.....	492 (574 equivalent)
Farthest indoor from first branch	.....	131

### Vertical differentials between units

Indoor/outdoor (outdoor higher)	.....	164
Indoor/outdoor (outdoor lower)	.....	131*
Indoor/indoor	.....	49

\* See engineering manual for detailed specification.

## Y-Series two-pipe cooling or heating system

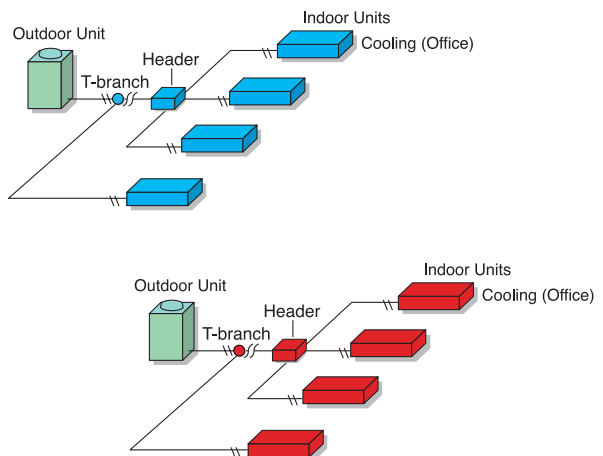

# Y-SERIES SPECIFICATIONS

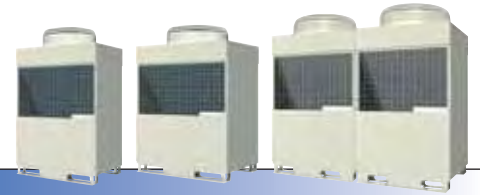

PUHY-P-TGMU(-BS) Specifications							
Model Name			PUHY-P72TGMU-A(-BS)	PUHY-P96TGMU-A(-BS)	PUHY-P108TGMU-A(-BS)	PUHY-P126TGMU-A(-BS)	PUHY-P144TGMU-A(-BS)
Power Source			208/230V, 3-phase, 60Hz				
Capacity *1	Cooling	Btu/h	72,000	96,000	108,000	126,000	144,000
	Heating	Btu/h	80,000	108,000	120,000	140,000	160,000
Power Input	Cooling	kW	6.48	8.67	9.73	11.36	14.2
	Heating	kW	6.33	8.56	9.92	11.67	13.67
Current (208/230V)	Cooling	A	19.9/18.0	26.7/24.1	30.0/27.1	35.0/31.6	43.8/39.6
	Heating	A	19.5/17.6	26.4/23.8	30.6/27.6	36.0/32.5	42.1/38.1
Fan	Type x Quantity		Propeller fan x 1	Propeller fan x 1	Propeller fan x 1	Propeller fan x 1	Propeller fan x 1
	Airflow Rate	CFM	7,050	7,050	7,050	8,450	8,450
	Motor Output	kW	0.38 x 1	0.38 x 1	0.38 x 1	0.64 x 1	0.64 x 1
Compressor	Type		Inverter-driven scroll hermetic				
	Motor Output	kW	4.7	6.7	8	8.5	9.7
	Crankcase Heater	W	57(230V)	57(230V)	57(230V)	57(230V)	57(230V)
	Lubricant		MEL32				
Refrigerant	Type		R410A				
External Finish			Pre-coated galvanized sheets (plus powder coating for -BS types) <Munsell 5Y 8/1 or similar>				
Dimensions	Height	Inches	72-15/32	72-15/32	72-15/32	72-15/32	72-15/32
	Width	Inches	39	39	39	50-13/16	50-13/16
	Depth	Inches	33-3/32	33-3/32	33-3/32	33-3/32	33-3/32
Net Weight	Pounds		490	524	524	616	616
Sound Level (as measured in anechoic room)	dB(A)		56	57	60	61	61
Protection Devices	High Pressure Protection		High pressure sensor, High pressure switch				
	Compressor/Fan		Overheat protection/Thermal switch				
	Inverter		Overcurrent and overheat protection				
Refrigerant Pipe Dimensions	Low Pressure	Inches	3/4 (Brazed & Flare)	7/8 (Brazed)	7/8 (Brazed)	1-1/8 (Brazed)	1-1/8 (Brazed)
	High Pressure	Inches	3/8 (Flare)	3/8 (Flare)	3/8 (Flare)	1/2 (Flare)	1/2 (Flare)
Indoor Unit	Total Capacity		50-130% of Outdoor Unit Capacity				
	Quantity		P06-P96/1-13	P06-P96/1-16	P06-P96/1-19	P06-P96/1-20	P06-P96/1-22
Operating Temperature Range	Cooling		Outdoor: 23°F DB to 109°F DB (32°F DB to 109°F DB if outdoor unit is lower than indoor unit)				
	Heating		Outdoor: -4°F WB to 60°F WB				

PUHY-P168TGMU-A(-BS) PUHY-P192TGMU-A(-BS) PUHY-P204TGMU-A(-BS) PUHY-P216TGMU-A(-BS) PUHY-P234TGMU-A(-BS)							
Model Name			PUHY-P168TGMU-A(-BS)	PUHY-P192TGMU-A(-BS)	PUHY-P204TGMU-A(-BS)	PUHY-P216TGMU-A(-BS)	PUHY-P234TGMU-A(-BS)
Power Source			208/230V, 3-phase, 60Hz				
Capacity *1	Cooling	Btu/h	168,000	192,000	204,000	216,000	234,000
	Heating	Btu/h	188,000	216,000	228,000	248,000	268,000
Power Input	Cooling	kW	14.97	17.34	18.71	19.92	21.62
	Heating	kW	15.02	17.48	18.65	21.03	23.11
Current (208/230V)	Cooling	A	46.1/41.7	53.4/48.3	57.7/52.1	61.4/55.5	66.6/60.3
	Heating	A	46.3/41.9	53.9/48.7	57.5/50.0	64.8/58.6	71.2/64.4
Fan	Type x Quantity		Propeller fan x 2	Propeller fan x 2	Propeller fan x 2	Propeller fan x 2	Propeller fan x 2
	Airflow Rate	CFM	14,100	14,100	14,100	14,100	14,100
	Motor Output	kW	0.38 x 2	0.38 x 2	0.38 x 2	0.38 x 2	0.38 x 2
Compressor	Type		Inverter-driven scroll hermetic and scroll hermetic				
	Motor Output	kW	6.8 + 5.3	8.2 + 5.3	9.3 + 5.3	10.1 + 5.3	10.9 + 5.3
	Crankcase Heater	W	57 x 2(230V)	57 x 2(230V)	57 x 2(230V)	57 x 2(230V)	57 x 2(230V)
	Lubricant		MEL32				
Refrigerant	Type		R410A				
External Finish			Pre-coated galvanized sheets (plus powder coating for -BS types) <Munsell 5Y 8/1 or similar>				
Dimensions	Height	Inches	72-15/32	72-15/32	72-15/32	72-15/32	72-15/32
	Width	Inches	78-3/8	78-3/8	78-3/8	78-3/8	78-3/8
	Depth	Inches	33-3/32	33-3/32	33-3/32	33-3/32	33-3/32
Net Weight	Pounds		1,022	1,022	1,022	1,022	1,022
Sound Level (as measured in anechoic room)	dB(A)		61	62	62	62.5	63
Protection Devices	High Pressure Protection		High pressure sensor, High pressure switch				
	Compressor/Fan		Overheat protection/Thermal switch				
	Inverter		Overcurrent and overheat protection				
Refrigerant Pipe Dimensions	Low Pressure	Inches	1-1/8 (Brazed)	1-1/8 (Brazed)	1-1/8 (Brazed)	1-1/8 (Brazed)	1-1/8 (Brazed)
	High Pressure	Inches	5/8 (Flare)	5/8 (Flare)	5/8 (Flare)	5/8 (Flare)	5/8 (Flare)
Indoor Unit	Total Capacity		50-130% of Outdoor Unit Capacity				
	Quantity		P06-P96/1-24	P06-P96/1-24	P06-P96/1-24	P06-P96/1-32	P06-P96/1-32
Operating Temperature Range	Cooling		Outdoor: 23°F DB to 109°F DB (32°F DB to 109°F DB if outdoor unit is lower than indoor unit)				
	Heating		Outdoor: -4°F WB to 60°F WB				

Note: Rating Conditions

\*1 Cooling: Indoor: 80°F (27°C) DB / 67°F (19°C) WB; Outdoor: 95°F (35°C) DB  
Heating: Indoor: 70°F (21°C) DB; Outdoor: 47°F (8°C) DB / 43°F (6°C) WB

-BS indicates seacoast protection option.

Specifications are subject to change.



CITY MULTI® S-Series:  
Building **Comfort**  
solutions in the home or  
small office.

## S-Series Solution

The CITY MULTI S-Series for homes and small offices offers all the features and benefits of our large commercial CITY MULTI Y-Series. The S-Series Solution features a single-phase outdoor unit with Variable Refrigerant Flow Zoning (VRFZ) technology and CITY MULTI Controls Network (CMCN) to cool or heat all zones with a variety of indoor unit styles. The compact outdoor unit utilizes R410A refrigerant and an INVERTER-driven compressor to use energy effectively. A maximum of eight CITY MULTI indoor units can be connected with up to 130% connected capacity, depending on diversity. CITY MULTI Controls Network intelligently manages the CITY MULTI building solution through zone controllers and system controllers and optionally through a networked PC to manage individual comfort and to provide the ultimate building comfort solution.



## S-Series two-pipe cooling or heating system

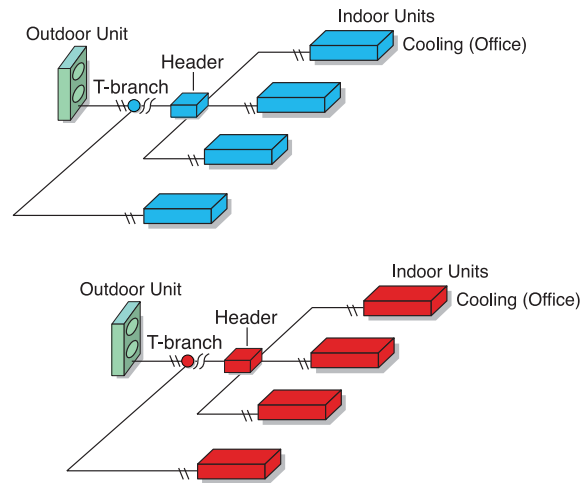

## Easy, flexible installation

The S-Series outdoor unit is easy to install and can be accessed for service through both a front and side panel.

The unit's compact dimensions and easy accessibility allow multiple units to be stacked side by side in tight areas, saving valuable space and resources.

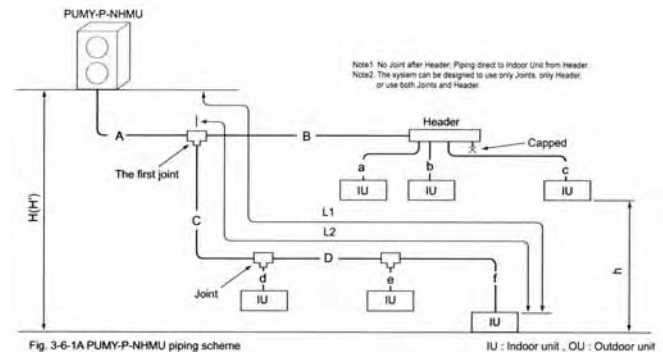
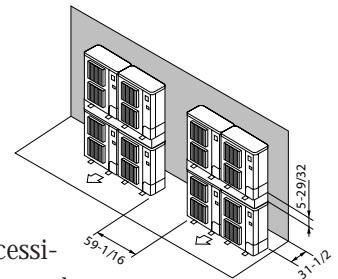

Fig. 3-6-1A PUMY-P-NHMU piping scheme

IU : Indoor Unit, OU : Outdoor Unit

Item	Piping in the figure	ft.
Total piping length	$A+B+C+D+a+b+c+d+e+f$	393'
Farthest IU from OU (L1)	$A+C+D+f / A+B+c$	262'
Farthest IU from the first Joint (L2)	$C+D+f / B+c$	98'
Height between OU and IU (OU above IU)	H	98'
Height between OU and IU (OU under IU)	H'	65'
Height between IU and IU	h	39'

OU: Outdoor Unit, IU: Indoor Unit

# S-SERIES SPECIFICATIONS



## PUMY-P-NHMU(-BS) Specifications

Model Name			PUMY-P48NHMU(-BS)
Power Source			208/230V, 1-phase, 60Hz
Capacity *1	Cooling	Btu/h	48,000
	Heating	Btu/h	54,000
Power Input	Cooling	kW	4.97
	Heating	kW	15.8
Current (208/230V)	Cooling	A	24.0-21.7
	Heating	A	23.6-21.3
Fan	Type x Quantity		Propeller fan x 2
	Airflow Rate	CFM	3,530
	Motor Output	kW	0.086 x 2
Compressor	Type		Inverter-driven scroll hermetic
	Motor Output	kW	2.4
	Crankcase Heater	W	--
	Lubricant		MEL56
Refrigerant	Type		R410A
External Finish (pre-coated galvanized sheets)			<Munsell 3Y 7.8/1/1> (plus powder coating for -BS types)
Dimensions	Height	Inches	53-5/32
	Width	Inches	37-13/32
	Depth	Inches	13 + 1-3/16
Net Weight		Pounds	287
Sound Level *2		dB(A)	50/52
Protection Devices	High Pressure Protection		High Pressure Sensor and Switch
	Compressor		Discharge Overheat and Overcurrent Protection
	Fan		Overheat and Voltage Protection
	Inverter		Overcurrent and Overheat Protection
Refrigerant Pipe Dimensions	Low Pressure	Inches	5/8 (Flare)
	High Pressure	Inches	3/8 (Flare)
Indoor Unit	Total Capacity		50-130% of Outdoor Unit Capacity
	Quantity		1-8
Operating Temperature Range	Cooling	Outdoor: 23°F DB to 115°F DB (50°F DB to 115°F DB if connecting PKFY-P06/08 Indoor Unit)	
	Heating	Outdoor: 10°F WB to 60°F WB	

**Note: Rating Conditions:** \*1 Cooling: Indoor: 80°F (27°C) DB / 67°F (19°C) WB; Outdoor: 95°F (35°C) DB  
 Heating: Indoor: 70°F (21°C) DB; Outdoor: 47°F (8°C) DB / 43°F (6°C) WB  
 \*2 As measured in an anechoic room.  
 -BS indicates seacoast protection option.

## Optional Parts for PUMY Outdoor Units

Description	Model	Remarks
Branch Joint	CMY-Y62-G-E	Optional branching piping kit (2 branches)
Header - 4 Branch	CMY-Y64-G-E	4 Branch Header includes sets for use with liquid and gas pipes
Header - 8 Branch	CMY-Y68-G-E	8 Branch Header includes sets for use with liquid and gas pipes
Drain Socket	PAC-SG61DS-E	For use when drain piping is necessary, use the drain socket or drain pan (option)
Drain Pan	PAC-SG64DP-E	
Air Outlet Guide	PAC-SG59SG-E	Need 2 pieces
Air Guide	PAC-SH63AG-E	Need 2 pieces

Specifications are subject to change.

# CITY MULTI® Indoor Units

## Multiple choices for indoor units

In today's modern building practices, the interior mechanical components are all designed for ultimate comfort and functionality. Aesthetics are also an important aspect of that comfort.

CITY MULTI VRFZ systems offer many sleek styles of ductless or ducted indoor units for various applications. Each indoor unit gives you ultimate zoning flexibility in each space. And all are compatible with the R2-Series, Y-Series, and S-Series outdoor units.

### PKFY: Wall-mounted

The PKFY wall-mounted indoor unit is very quiet with sound ratings as low as 32 dB(A). The seven sizes available for the PKFY



models are 6,000, 8,000, 12,000, 15,000, 18,000, 24,000, and 30,000 Btu/h. This style of indoor unit is well-suited for hotels, assisted living facilities, offices, residences, and other applications where wall space is available.

### PLFY: Ceiling-recessed cassette with up to four-way airflow

The PLFY is our ceiling-recessed type indoor unit with a two-, three-, or four-way airflow option. These models give you discreet individual room control and four fan speed settings.



They can be installed in a lay-in tile or dry-wall ceiling. The unit can be serviced by simply removing the grill. The PLFY units have a built-in, drain-lift mechanism with 33 inches of condensation lift. They are extremely quiet with sound ratings as low as 24 dB(A)

and can be connected to ventilation air. The six sizes available for the PLFY are 12,000, 15,000, 18,000, 24,000, 30,000, and 36,000 Btu/h. PLFY models are well-suited for office buildings, school classrooms, computer server rooms, and other applications where at least 12" of space is available above the ceiling.

### PMFY: Ceiling-recessed cassette with one-way airflow

The PMFY is a ductless, one-way, ceiling-recessed cassette indoor unit that can be connected to ventilation air. This unit is very easy to install and is offered in four capacities: 6,000, 8,000, 12,000, and 15,000 Btu/h. The PMFY model is designed for use in areas that cannot support ductwork or lack the sufficient space to support wall-mounted units.



### PCFY: Ceiling-suspended

THE PCFY is a ceiling-suspended indoor unit. Four models are available in capacities of 15,000, 24,000, 30,000, and 36,000 Btu/h.



The PCFY's auto-vane swings the conditioned air and distributes it throughout the room. This model is ideal for restaurants, classrooms, and stores.

### PDFY and PEFY: Ceiling-concealed ducted

The PDFY and PEFY are concealed-type, ducted indoor units with the ability to attach ductwork and can be connected to ventilation air. They are installed



above the ceiling and allow multiple outlets to be ducted from them. The low profile design allows maximum flexibility in air-conditioning hard-to-reach zones or for zones that are larger in size. The PDFY and PEFY are extremely quiet. Capacities range from 6,000 to 96,000 Btu/h. This style of indoor unit is well-suited for office buildings, schools, hotels, assisted-living facilities, residences, and other applications where ceiling space is available and the most discreet mechanical system is desired.

### PFFY: Floor-standing

The PFFY floor-mounted models are available as an exposed or concealed indoor unit. These two models are available in six nominal capacities: 6,000, 8,000, 12,000, 15,000, 18,000, and 24,000 Btu/h. The PFFY-NEMU requires no finish work and is perfect for any application, especially schools, office buildings, and hotels. While the PFFY-NRMU is designed for large jobs requiring a built-in, concealed floor-mounted unit, it practically disappears in the room.



Floor-Standing Exposed  
PFFY-NEMU



Floor-Standing  
Concealed  
PFFY-NRMU



# CITY MULTI® Indoor Units

Customize your CITY MULTI solution  
The CITY MULTI R2-Series, Y-Series, and S-Series provide flexible solutions for your cooling and heating needs by using a variety of different indoor units. Choose from wall-mounted, ceiling-recessed, ceiling-suspended, ceiling-concealed ducted, or floor-standing models. All are quiet, easy to maintain, and efficient. The chart below illustrates the capacity size for each model.

## R2-Series: Simultaneous Cooling and Heating

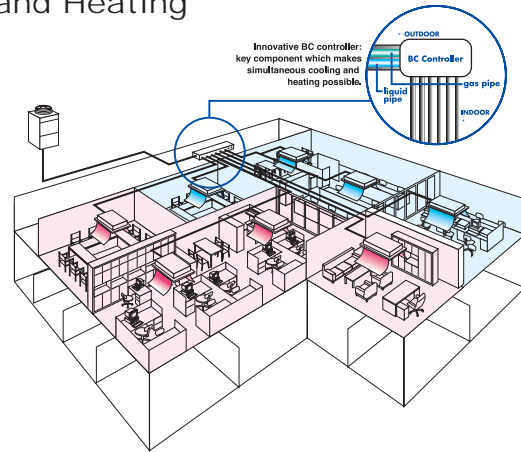

## Y-Series: Heat Pump Operation

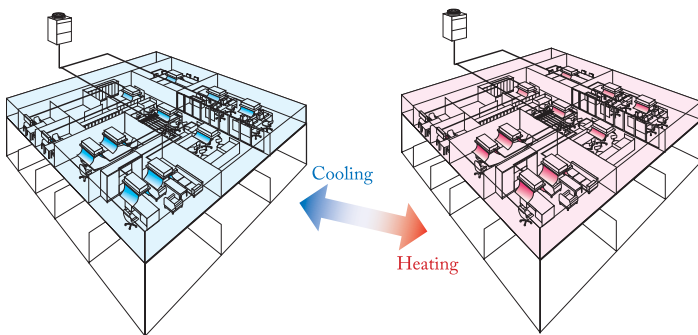

## S-Series: Heat Pump Operation



Capacity Code	Wall-mounted PKFY-P- NAMU/NGMU/NFMU-E	Ceiling-recessed Cassette PLFY-P-NAMU-E	Ceiling-recessed Cassette PMFY-P-NBMU-E	Ceiling-suspended PCFY-P-NGMU-E	Ceiling-concealed (ducted) PDFY-P-NMU-E	Ceiling-concealed (ducted low-profile) PEFY-P-NMLU-E	Ceiling-concealed (ducted alternate high-static option) PEFY-P-NMHU-E	Floor-standing (exposed/concealed) PEFY-P-NEMU/NRMU-E
Nominal Btu/h								
6,000 Btu/h	●		●		●	●		●
8,000 Btu/h	●		●		●	●		●
12,000 Btu/h	●	●	●		●	●		●
15,000 Btu/h	●	●	●	●	●		●	●
18,000 Btu/h	●	●			●		●	●
24,000 Btu/h	●	●		●	●		●	●
27,000 Btu/h					●		●	
30,000 Btu/h	●	●		●	●		●	
36,000 Btu/h		●		●	●		●	
48,000 Btu/h					●		●	
54,000 Btu/h							●	
72,000 Btu/h							●	
96,000 Btu/h							●	

WALL-MOUNTED

# PKFY

Elegant design and compact dimensions ideal for offices, classrooms, and residential uses.



PKFY-P-NAMU-E

PKFY-P-NGMU-E

PKFY-P-NFMU-E

Capacity range: 6,000 to 30,000 Btu/h

## A wide selection for your design and performance needs

Whatever the size or shape of your room, there is a Mitsubishi Electric PKFY unit that's just right, delivering the style and performance you demand and deserve. PKFY units mount high on the wall and blend beautifully into any space. They are compact and lightweight. In addition, they are extremely quiet with one of the lowest sound ratings available from any manufacturer. When it comes to comfort, the PKFY auto-vane feature delivers optimal air distribution and uniform temperatures throughout your space. All of this performance and design flexibility comes in a unit that is remarkably easy to install and maintain. The template and back-mounting plate shipped with each unit make installation a snap.

## Front grille opens for easy filter cleaning

The front grille opens easily with no tools needed to gain quick access to the filter. The filter can be removed and cleaned as needed.

Front grille opens for filter access

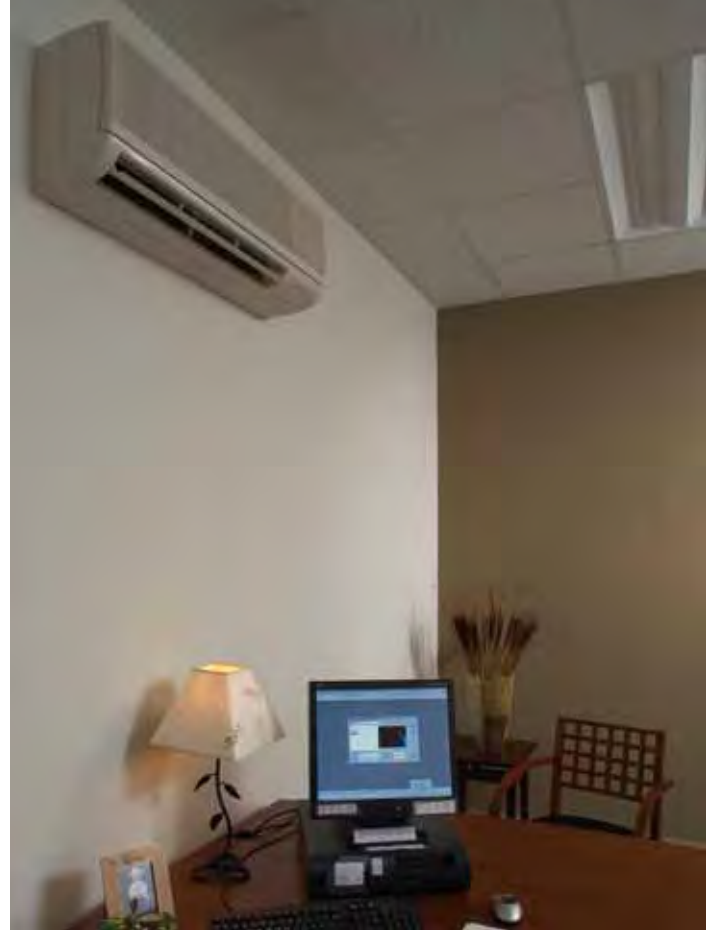
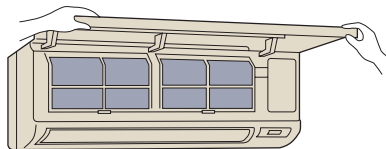

## Operation is among the quietest available

The unit incorporates a random-pitch fan to assure quiet operation. The optimal design of the airflow passage features a small fan diameter to allow for a compact installation. Thanks to practical casing configuration, airflow generated by the fan is distributed uniformly. This design also suppresses condensation.

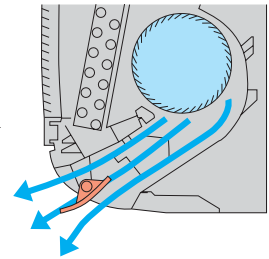

### Features

*Quiet operation*

*Lightweight*

*Auto-vane*

*Microprocessor control*

*Self-diagnostics*

### Benefits

No noise pollution. Ideal for sound-sensitive applications like hotel rooms, libraries, and classrooms.

Easy to install, saving time and money.

Excellent air distribution eliminates hot and cold spots and drafts.

Built-in electronics ensure efficient operation and maximum performance for optimum comfort.

Easy to service and maintain.

# PKFY-P-NAMU/NGMU/NFMU-E SPECIFICATIONS



PKFY-P-NAMU-E



PKFY-P-NGMU-E



PKFY-P-NFMU-E

PKFY Specifications						
Model Name			PKFY-P06NAMU-E	PKFY-P08NAMU-E	PKFY-P12NGMU-E	PKFY-P15NGMU-E
Power Source	208/230V, 1-phase, 60Hz					
Cooling Capacity *1	Btu/h		6,000	8,000	12,000	15,000
Heating Capacity *1	Btu/h		6,700	9,000	13,500	17,000
Power Consumption	Cooling	W	30	30	70	70
	Heating	W	30	30	70	70
Current	Cooling	A	0.15	0.15	0.34	0.34
	Heating	A	0.15	0.15	0.34	0.34
External Finish (Munsell No.)			2.60Y 8.66/0.69	2.60Y 8.66/0.69	0.70Y 8.59/0.97	0.70Y 8.59/0.97
Dimensions	Height	Inches	11-5/8	11-5/8	13-13/32	13-13/32
	Width	Inches	32-3/32	32-3/32	39	39
	Depth	Inches	6-1/4	6-1/4	9-9/32	9-9/32
Net Weight	Unit	Pounds	19	19	36	36
Heat Exchanger	Cross Fin (Aluminum Plate Fin and Copper Tube)					
Fan	Type x Quantity	Line Flow Fan x 1				
	Airflow Rate *2	CFM	173-184-198-208	173-184-198-208	283-335-371-406	283-335-371-406
	Motor Type	Single-phase Induction Motor				
	Motor Output	W	17	17	30	30
Air Filter	PP Honeycomb					
Refrigerant Pipe	Low Pressure (Flare)	Inches	1/2	1/2	1/2	1/2
Dimensions	High Pressure (Flare)	Inches	1/4	1/4	1/4	1/4
Drainpipe Dimension			Inches I.D. 5/8	Inches I.D. 5/8	Inches I.D. 13/16	Inches I.D. 13/16
Sound Levels *2	Low-Mid1-Mid2-High	dB(A)	32-33-35-36	32-33-35-36	32-36-40-42	32-36-40-42

PKFY Specifications <i>continued</i>						
Model Name			PKFY-P18NFMU-E	PKFY-P24NFMU-E	PKFY-P30NFMU-E	
Power Source	208/230V, 1-phase, 60Hz					
Cooling Capacity *1	Btu/h		18,000	24,000	30,000	
Heating Capacity *1	Btu/h		20,000	27,000	34,000	
Power Consumption	Cooling	W	90	90	120	
	Heating	W	90	90	120	
Current	Cooling	A	0.44	0.44	0.58	
	Heating	A	0.44	0.44	0.58	
External Finish (Munsell No.)			3.4Y 7.7/0.8	3.4Y 7.7/0.8	3.4Y 7.7/0.8	
Dimensions	Height	Inches	13-13/32	13-13/32	13-13/32	
	Width	Inches	55-1/8	55-1/8	66-5/32	
	Depth	Inches	9-9/32	9-9/32	9-9/32	
Net Weight	Unit	Pounds	53	53	62	
Heat Exchanger	Cross Fin (Aluminum Plate Fin and Copper Tube)					
Fan	Type x Quantity	Line Flow Fan x 2				
	Airflow Rate *2	CFM	494-636	494-636	777-989	
	Motor Type	Single-phase Induction Motor				
	Motor Output	W	45	45	70	
Air Filter	PP Honeycomb					
Refrigerant Pipe	Low Pressure (Flare)	Inches	1/2	5/8	5/8	
Dimensions	High Pressure (Flare)	Inches	1/4	3/8	3/8	
Drainpipe Dimension			Inches I.D. 13/16	Inches I.D. 13/16	Inches I.D. 13/16	
Sound Levels *2	Low-High	dB(A)	39-45	39-45	46-49	

**Note:** \*1 Cooling / Heating capacity indicates the maximum value at operation under the following conditions:  
 Cooling: Indoor: 80°F (27°C) DB / 67°F (19°C) WB; Outdoor: 95°F (35°C) DB  
 Heating: Indoor: 70°F (21°C) DB; Outdoor: 47°F (8°C) DB / 43°F (6°C) WB

\*2 Airflow rate / sound levels are at (Low-Mid1-Mid2-High) or (Low-High)

Ventilation Air: Providing sufficient ventilation air is an important part of every building design. ASHRAE standard 62 provides the minimum ventilation air requirements. Also check local codes.

Specifications are subject to change.



CEILING-RECESSED CASSETTE  
FOUR-WAY AIRFLOW

PLFY

Customize the airflow  
pattern to meet your needs.



Capacity range: 12,000 – 36,000 Btu/h

High performance and versatility

The PLFY looks great and works beautifully. The four-way cassette-type unit is compact and recesses easily into a ceiling space so that all you see is an attractive, flush-mounted grille. Beneath that elegant exterior is a powerful, high-performance machine with a built-in drain lift-up mechanism with a thirty-three inch lift. The fan is engineered to provide optimum air distribution with minimal sound: in the low 20's to the low 40's dB(A) range. When it comes to flexibility, this unit not only brings outside air into your space, but can also branch over to air-condition an adjacent room.

Easy maintenance, long-life filter

The washable filter provides about 2,500 hours of use in a normal office environment before cleaning is needed.

Unit height of only 10 1/4" and 11 3/4":  
great for low-ceiling space applications

The PLFY has a unit height of only 10-1/4" or 11-3/4", depending on the model, to provide great looking installations in low-ceiling areas with very limited space.

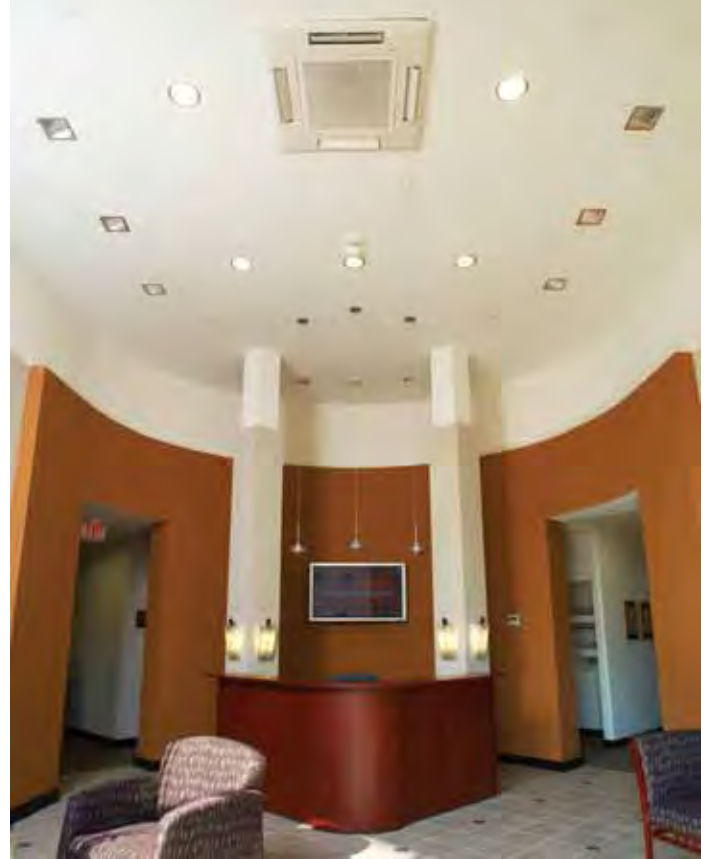
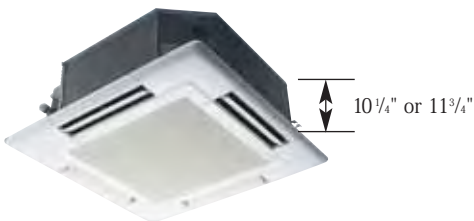

Drain water lifted up to 33 inches

The drainpiping of the PLFY can be positioned anywhere up to 33 inches from the ceiling's surface, allowing for long piping and versatility. A built-in switch halts operation if an error with the pump occurs, ensuring that no water leaks from the unit.

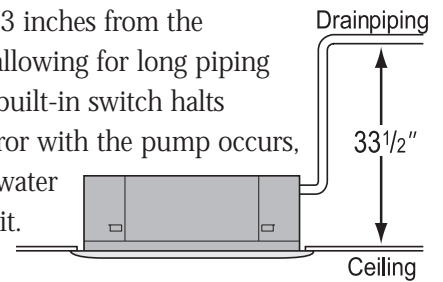

Corner-pocket design simplifies  
maintenance and installation

Access the unit through the corner pockets equipped on all four corners of the grille to complete installation, maintenance work, and height adjustment.



Customize the airflow pattern to meet  
your needs

The different airflow patterns provide the best solution for a variety of room layouts and air-conditioning requirements. For extra versatility, you can select from two-, three-, or four-way airflow.

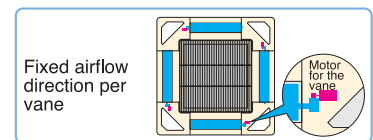
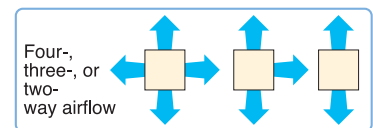

# PLFY-P-NAMU-E SPECIFICATIONS

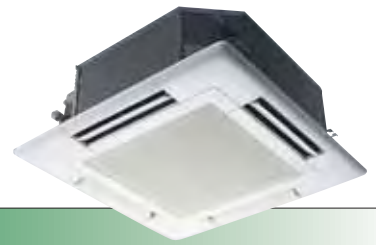

PLFY-P-NAMU-E Specifications				
Model Name	PLFY-P12NAMU-E		PLFY-P15NAMU-E	PLFY-P18NAMU-E
Power Source	208/230V, 1-phase, 60Hz			
Cooling Capacity *1	Btu/h	12,000	15,000	18,000
Heating Capacity *1	Btu/h	13,500	17,000	20,000
Power Consumption	Cooling	W	140	140
	Heating	W	140	140
Current	Cooling	A	0.68	0.68
	Heating	A	0.68	0.68
External Finish Color	Grille: Munsell 0.70Y 8.59/0.97			
Dimensions	Height	Inches	10-3/16	10-3/16
	Width	Inches	33-3/32	33-3/32
	Depth	Inches	33-3/32	33-3/32
Net Weight *2	Unit/Grille	Pounds	49/11	53/11
Heat Exchanger	Cross Fin (Aluminum Plate Fin and Copper Tube)			
Fan	Type x Quantity	Turbo Fan x 1		
	Airflow Rate *3	CFM	388-424-459-494	424-459-494-565 494-530-565-636
	Motor Type	Single-phase Induction Motor		
	Motor Output	W	70	70
Air Filter	PP Honeycomb			
Refrigerant Pipe Dimensions	Low Pressure (Flare)	Inches	1/2	1/2
	High Pressure (Flare)	Inches	1/4	1/4
Drainpipe Dimension	Inches		O.D. 1-1/4	
Sound Levels *3	(Low-Mid1-Mid2-High)	dB(A)	24-27-28-30	27-28-30-32 27-28-31-33

PLFY-P-NAMU-E Specifications <i>continued</i>				
Model Name	PLFY-P24NAMU-E		PLFY-P30NAMU-E	PLFY-P36NAMU-E
Power Source	208/230V, 1-phase, 60Hz			
Cooling Capacity *1	Btu/h	24,000	30,000	36,000
Heating Capacity *1	Btu/h	27,000	34,000	40,000
Power Consumption	Cooling	W	140	270
	Heating	W	140	270
Current	Cooling	A	0.68	1.3
	Heating	A	0.68	1.3
External Finish Color	Grille: Munsell 0.70Y 8.59/0.97			
Dimensions	Height	Inches	10-3/16	11-3/4
	Width	Inches	33-3/32	33-3/32
	Depth	Inches	33-3/32	33-3/32
Net Weight *2	Unit/Grille	Pounds	53/11	66/11
Heat Exchanger	Cross Fin (Aluminum Plate Fin and Copper Tube)			
Fan	Type x Quantity	Turbo Fan x 1		
	Airflow Rate *3	CFM	530-565-636-706	706-812-918-989 777-883-989-1,059
	Motor Type	Single-phase Induction Motor		
	Motor Output	W	70	110
Air Filter	PP Honeycomb			
Refrigerant Pipe Dimensions	Low Pressure (Flare)	Inches	5/8	5/8
	High Pressure (Flare)	Inches	3/8	3/8
Drainpipe Dimension	Inches		O.D. 1-1/4	
Sound Levels *3	(Low-Mid1-Mid2-High)	dB(A)	28-30-33-34	34-36-40-41 37-40-43-44

**Note:** \*1 Cooling / Heating capacity indicates the maximum value at operation under the following conditions:  
 Cooling: Indoor: 80°F (27°C) DB / 67°F (19°C) WB; Outdoor: 95°F (35°C) DB  
 Heating: Indoor: 70°F (21°C) DB; Outdoor: 47°F (8°C) DB / 43°F (6°C) WB

\*2 Net weight is shown for unit/grille

\*3 Airflow rate / sound levels are at (Low-Mid1-Mid2-High)

Ventilation Air: Providing sufficient ventilation air is an important part of every building design. ASHRAE standard 62 provides the minimum ventilation air requirements. Also check local codes.

Specifications are subject to change.

CEILING-RECESSED CASSETTE  
ONE-WAY AIRFLOW

**PMFY**

Compact and lightweight –  
perfect for limited  
ceiling space applications.

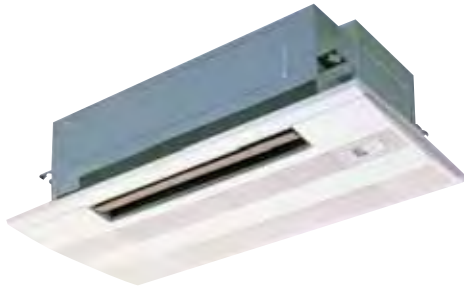

**Capacity range: 6,000 – 15,000 Btu/h**

**Ideal for small spaces**

The PMFY models are one-way, ceiling-recessed cassette units perfect for shallow ceiling spaces. The PMFY unit moves air in one direction and can bring in fresh ventilation. It is designed especially for use in areas like hotel rooms that cannot support ductwork or lack sufficient space to allow for wall-mounted units. The PMFY is available in 6,000, 8,000, 12,000, and 15,000 Btu/h capacities. The PMFY can support outside air introduction with fan assist.

**Compact size for easy installation and maintenance**

Unit body size has been standardized for all models at 31-31/32" for easier installation. This profile is the smallest of all CITY MULTI ceiling models with a height of only 9-1/16" — ideal for tight locations. Body weight is only 31 pounds for the main unit and 7 pounds for the panel, making this unit one of the lightest in the industry.

Model Name	Cooling Btu/h	Heating Btu/h	Dimensions Inches (H x W x D)
PMFY-P06NBMU-E	6,000	6,700	9-1/16 x 31-31/32 x 15-9/16
PMFY-P08NBMU-E	8,000	9,000	9-1/16 x 31-31/32 x 15-9/16
PMFY-P12NBMU-E	12,000	13,500	9-1/16 x 31-31/32 x 15-9/16
PMFY-P15NBMU-E	15,000	17,000	9-1/16 x 31-31/32 x 15-9/16

**Quiet operation**

Newly-developed airflow control technology reduces operation sound level to only 27 dB(A) for industry-leading quiet performance.

**Drain lift-up mechanism**

The drain can be positioned anywhere up to 23-5/8" above the ceiling's surface.

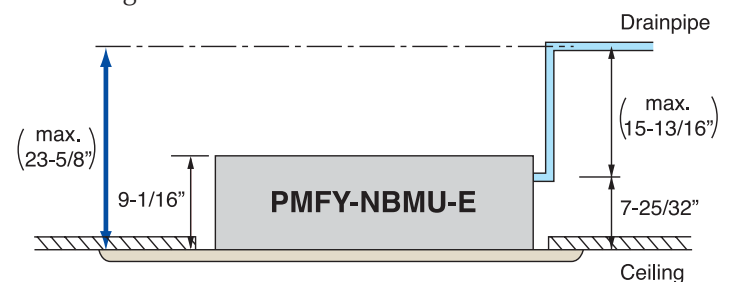



# PMFY-P-NBMU-E SPECIFICATIONS



PMFY-P-NBMU-E Specifications						
Model Name			PMFY-P06NBMU-E	PMFY-P08NBMU-E	PMFY-P12NBMU-E	PMFY-P15NBMU-E
Power Source			208/230V, 1-phase, 60Hz			
Cooling Capacity *1	Btu/h		6,000	8,000	12,000	15,000
Heating Capacity *1	Btu/h		6,700	9,000	13,500	17,000
Power Consumption	Cooling	W	40	40	40	50
	Heating	W	40	40	40	50
Current	Cooling	A	0.20	0.20	0.21	0.26
	Heating	A	0.20	0.20	0.21	0.26
External Finish Color			Grille: Munsell 0.98Y 8.99/0.63			
Dimensions	Height	Inches	9-1/16	9-1/16	9-1/16	9-1/16
	Width	Inches	31-31/32	31-31/32	31-31/32	31-31/32
	Depth	Inches	15-9/16	15-9/16	15-9/16	15-9/16
Net Weight *2	Unit/Grille	Pounds	31/7	31/7	31/7	31/7
Heat Exchanger			Cross Fin (Aluminum Plate Fin and Copper Tube)			
Fan	Type x Quantity		Line Flow Fan x 1			
	Airflow Rate *3	CFM	230-254-283-307	258-283-304-328	258-283-304-328	272-307-343-378
	Motor Type		DC Brushless Motor			
	Motor Output	W	28	28	28	28
Air Filter			PP Honeycomb			
Refrigerant Pipe	Low Pressure (Flare)	Inches	1/2	1/2	1/2	1/2
Dimensions	High Pressure (Flare)	Inches	1/4	1/4	1/4	1/4
Drainpipe Dimension		Inches	O.D. 1-1/32	O.D. 1-1/32	O.D. 1-1/32	O.D. 1-1/32
Sound Levels *3	(Low-Mid1-Mid2-High)	dB(A)	27-30-33-35	32-34-36-37	32-34-36-37	33-35-37-39

**Note:** \*1 Cooling / Heating capacity indicates the maximum value at operation under the following conditions:

Cooling: Indoor: 80°F (27°C) DB / 67°F (19°C) WB; Outdoor: 95°F (35°C) DB

Heating: Indoor: 70°F (21°C) DB; Outdoor: 47°F (8°C) DB / 43°F (6°C) WB

\*2 Net weight is shown for unit/grille

\*3 Airflow rate / sound levels are at (Low-Mid1-Mid2-High)

Ventilation Air: Providing sufficient ventilation air is an important part of every building design.

ASHRAE standard 62 provides the minimum ventilation air requirements. Also check local codes.

PMFY-P-NBMU-E Outside Air Capability		
Two 4-inch Diameter Ports		
Model	Airflow (high)	Total Air Capacity Taken from Outside
PMFY-P06NBMU-E	305 CFM	60 CFM
PMFY-P08NBMU-E	325 CFM	60 CFM
PMFY-P12NBMU-E	325 CFM	60 CFM
PMFY-P15NBMU-E	375 CFM	70 CFM

Note: Fan assist for intake air is required.

Specifications are subject to change.

CEILING-SUSPENDED

# PCFY

Compact design ideal for classrooms, restaurants, and stores.



**Capacity range: 15,000 – 36,000 Btu/h**

Superior performance provides plenty of relief

Powerful cooling and heating performance is what the PCFY style is all about. This easy to install, ceiling-suspended unit delivers enough cold or hot air to make any space more comfortable. Manually adjusted, over-sized swing louvers direct the airflow left or right, covering the entire space quietly and efficiently. The dimensions of the compact PCFY style make it perfect for restaurants, kitchens, and other large commercial spaces where ovens and other equipment add to an already taxed cooling or heating load. The PCFY is available in 15,000, 24,000, 30,000, and 36,000 Btu/h capacities.

Quiet, powerful airflow

Model Name	Airflow Rate	Sound Level at Low Airflow
PCFY-PI5NGMU-E	283-353-388-424	29 dB(A)
PCFY-P24NGMU-E	424-494-565-636	32 dB(A)
PCFY-P30NGMU-E	636-706-812-883	36 dB(A)
PCFY-P36NGMU-E	918-989-1,130-1,236	37 dB(A)

## Ceiling-suspended specifications

Model		P15	P24	P30	P36
Cool	Btu/h	15,000	24,000	30,000	36,000
Heat	Btu/h	17,000	27,000	34,000	40,000

## Strong, efficient airflow

The PCFY's auto-vane and wide-range outlet swings the conditioned air and distributes it uniformly to all corners of the room, even when installed at a ceiling height of 11'5". Accessory filters are also available to increase filtration effectiveness and the time span between service calls.

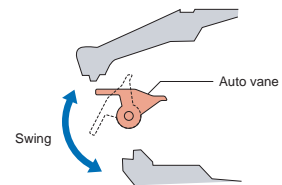

## Easy install with direct suspension

The PCFY's direct suspension allows it to be installed onto most ceiling surfaces quickly and securely using only suspension bolts and the PCFY's durable attachment fixture.

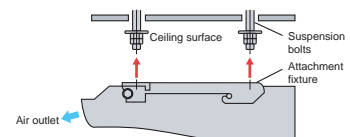

# PCFY SPECIFICATIONS



PCFY Specifications						
Model Name		PCFY-P15NGMU-E	PCFY-P24NGMU-E	PCFY-P30NGMU-E	PCFY-P36NGMU-E	
Power Source		208/230V, 1-phase, 60Hz				
Cooling Capacity	Btu/h *1	15,000	24,000	30,000	36,000	
Heating Capacity	Btu/h *1	17,000	27,000	34,000	40,000	
Power Consumption	Cooling	kW	0.08	0.09	0.23	0.27
	Heating	kW	0.08	0.09	0.23	0.27
Current	Cooling	A	0.4	0.45	1.12	1.32
	Heating	A	0.4	0.45	1.12	1.32
External Finish		Munsell No. 0.70Y 8.59/0.97				
Dimensions	Height	Inches	8-9/32		10-21/32	
	Width	Inches	39-3/8	51-9/32		63-25/32
	Depth	Inches	26-25/32			
Net Weight	Unit	Pounds	60	75	82	95
Heat Exchanger		Cross Fin (Aluminum Plate Fin and Copper Tube)				
Fan	Type x Quantity		Sirocco Fan x 2	Sirocco Fan x 3		Sirocco Fan x 4
	Airflow Rate *2	CFM	283-353-388-424	424-494-565-636	636-706-812-883	918-989-1,130-1,236
	Motor Type		Single Phase Induction Motor			
	Motor Output	kW	0.054	0.070	0.090	0.150
Air Filter		PP Honeycomb				
Refrigerant Pipe Dimensions	Low Pressure	Inches	1/2 (Flare)		5/8 (Flare)	
	High Pressure	Inches	1/4 (Flare)		3/8 (Flare)	
Drainpipe Dimension		Inches	O.D. 1-1/32			
Sound Levels	Low-Mid1-Mid2-High	dB(A) *2	29-33-36-38	32-34-37-39	36-38-41-43	37-39-42-44

**Note:** \*1 Cooling/Heating capacity indicates the maximum value at operation under the following conditions:  
 Cooling: Indoor: 80°F (27°C) DB/67°F (19°C) WB; Outdoor: 95°F (35°C) DB  
 Heating: Indoor: 70°F (21°C) DB; Outdoor: 47°F (8°C) DB/43°F (6°C) WB

Specifications are subject to change.



CEILING-CONCEALED  
**PDFY/PEFY**

Flexible design allows elegant interior layout.



**Capacity range: 6,000 – 96,000 Btu/h**

Designed to be neither seen nor heard, just to perform

The PDFY and PEFY models are high-performance, ceiling-concealed, ducted indoor units. In fact, if it weren't for the constantly comfortable environment these units deliver, you would not even know they were there. The ducted fan coils are designed to be installed above the ceiling, hidden from public view. And they're extremely quiet, with sound ratings that range from 25 – 54 dB(A). **Hidden** doesn't mean hard to reach. In fact, the PDFY and PEFY fan coils are extremely easy to access and maintain according to their application. They open on one side so you can easily access the fan or motor for maintenance. They're also easy to customize to your cooling and heating needs. The external static pressure settings are adjustable to meet different application conditions, such as the use of a high-performance filter.

**Choice of external static pressure**

The additional external static pressure capacity provides flexibility for duct extension, branching, and air outlet configuration. Factory set to 0.24 in. W.G. can be field adjusted to 0.16 in. W.G. or 0.40 in. W.G. to match installed ductwork for PDFY indoor units. The PEFY indoor units are available in a low-profile and an alternate high-static option.

Quiet operation thanks to the use of a newly designed centrifugal fan

**PDFY Operating Sound Level**

Sound Level dB(A)	Model		P06	P08	P12	P15	P18	P24	P27	P30	P36	P48
	Fan Speed	Low-High	28-36	28-36	28-36	34-39	34-39	30-39	32-40	34-42	38-45	43-47

Variety of layouts for a flexible installation

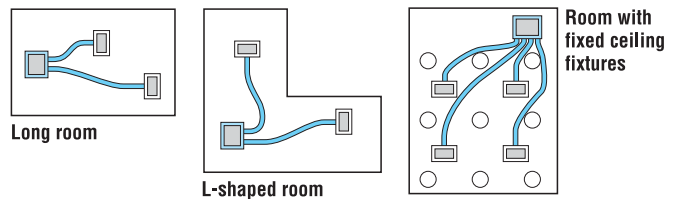

Multiple installation patterns for assorted applications and locations

**Bottom intake (using canvas duct)**

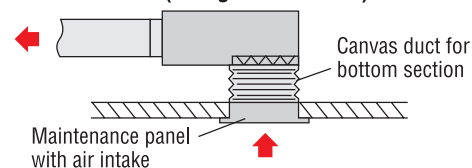

**All-duct system**

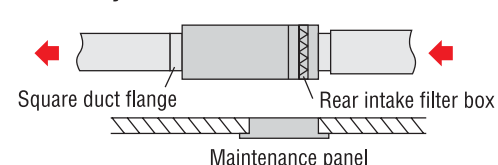

# PDFY-P-NMU-E SPECIFICATIONS

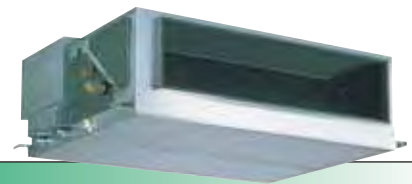

PDFY-P-NMU-E Specifications							
Model Name			PDFY-P06NMU-E	PDFY-P08NMU-E	PDFY-P12NMU-E	PDFY-P15NMU-E	PDFY-P18NMU-E
Power Source			208/230V, 1-phase, 60Hz				
Cooling Capacity *1		Btu/h	6,000	8,000	12,000	15,000	18,000
Heating Capacity *1		Btu/h	6,700	9,000	13,500	17,000	20,000
Power Consumption	Cooling	W	120	120	120	150	150
	Heating	W	120	120	120	150	150
Current	Cooling	A	0.61/0.68	0.61/0.68	0.61/0.68	0.77/0.85	0.77/0.85
	Heating	A	0.61/0.68	0.61/0.68	0.61/0.68	0.77/0.85	0.77/0.85
External Finish			Unit: Galvanized Steel Plate				
Dimensions	Height	Inches	11-5/8	11-5/8	11-5/8	11-5/8	11-5/8
	Width	Inches	27-31/32	27-31/32	27-31/32	37-13/16	37-13/16
	Depth	Inches	28-15/16	28-15/16	28-15/16	28-15/16	28-15/16
Net Weight	Unit	Pounds	57	57	60	71	75
Heat Exchanger			Cross Fin (Aluminum Plate Fin and Copper Tube)				
Fan	Type x Quantity		Sirocco Fan x 1	Sirocco Fan x 1	Sirocco Fan x 1	Sirocco Fan x 2	Sirocco Fan x 2
	Airflow Rate *2	CFM	211-229-264-300	211-229-264-300	211-229-264-300	353-388-441-494	353-388-441-494
	Ext. Static Press (230V)	In. WG	0.16-0.24-0.40	0.16-0.24-0.40	0.16-0.24-0.40	0.16-0.24-0.40	0.16-0.24-0.40
	Motor Type		Single-phase Induction Motor				
	Motor Output	W	75	75	75	85	85
Air Filter			Standard Filter				
Refrigerant Pipe Dimensions	Low Pressure (Flare)	Inches	1/2	1/2	1/2	1/2	1/2
	High Pressure (Flare)	Inches	1/4	1/4	1/4	1/4	1/4
Drainpipe Dimension		Inches	O.D. 1-1/4				
Sound Levels *2 (Low-Mid1-Mid2-High)		dB(A) @ 230V	28-30-33-36	28-30-33-36	28-30-33-36	34-36-37-39	34-36-37-39

Model Name			PDFY-P24NMU-E	PDFY-P27NMU-E	PDFY-P30NMU-E	PDFY-P36NMU-E	PDFY-P48NMU-E
Power Source			208/230V, 1-phase, 60Hz				
Cooling Capacity *1		Btu/h	24,000	27,000	30,000	36,000	48,000
Heating Capacity *1		Btu/h	27,000	30,000	34,000	40,000	54,000
Power Consumption	Cooling	W	170	180	210	290	390
	Heating	W	170	180	210	290	390
Current	Cooling	A	0.87/0.96	0.94/1.04	1.07/1.19	1.48/1.64	1.99/2.21
	Heating	A	0.87/0.96	0.94/1.04	1.07/1.19	1.48/1.64	1.99/2.21
External Finish			Unit: Galvanized Steel Plate				
Dimensions	Height	Inches	11-5/8	11-5/8	11-5/8	13-7/32	13-7/32
	Width	Inches	45-11/16	45-11/16	45-11/16	59-15/32	59-15/32
	Depth	Inches	28-15/16	28-15/16	28-15/16	30-17/32	30-17/32
Net Weight	Unit	Pounds	86	86	86	115	115
Heat Exchanger			Cross Fin (Aluminum Plate Fin and Copper Tube)				
Fan	Type x Quantity		Sirocco Fan x 2	Sirocco Fan x 2	Sirocco Fan x 2	Sirocco Fan x 2	Sirocco Fan x 2
	Airflow Rate *2	CFM	441-494-565-635	477-547-618-689	494-582-653-741	688-988	847-1200
	Ext. Static Press (230V)	In. WG	0.16-0.24-0.40	0.16-0.24-0.40	0.16-0.24-0.46	0.24-0.46-0.60	0.24-0.46-0.60
	Motor Type		Single-phase Induction Motor				
	Motor Output	W	95	95	95	140	190
Air Filter			Standard Filter				
Refrigerant Pipe Dimensions	Low Pressure (Flare)	Inches	5/8	5/8	5/8	5/8	5/8
	High Pressure (Flare)	Inches	3/8	3/8	3/8	3/8	3/8
Drainpipe Dimension		Inches	O.D. 1-1/4				
Sound Levels *2 (Low-Mid1-Mid2-High)		dB(A) @ 230V	30-34-36-39	32-36-38-40	34-37-40-42	38-45	43-47

**Note:** \*1 Cooling /Heating capacity indicates the maximum value at operation under the following conditions:  
 Cooling: Indoor: 80°F (27°C) DB/67°F (19°C) WB; Outdoor: 95°F (35°C) DB  
 Heating: Indoor: 70°F (21°C) DB; Outdoor: 47°F (8°C) DB/43°F (6°C) WB

\*2 Airflow rate/sound levels are at (Low-Mid1-Mid2-High) or (Low-High)

Ventilation Air: Providing sufficient ventilation air is an important part of every building design. ASHRAE standard 62 provides the minimum ventilation air requirements. Also check local codes.

Specifications are subject to change.

# PEFY-P-NMHU-E SPECIFICATIONS

ALTERNATE HIGH STATIC OPTION

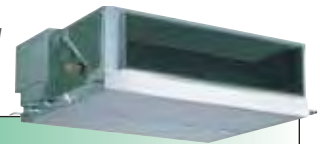

PEFY-P-NMHU-E Specifications							
Model Name			PEFY-P15NMHU-E	PEFY-P18NMHU-E	PEFY-P24NMHU-E	PEFY-P27NMHU-E	PEFY-P30NMHU-E
Power Source			208/230V, 1-phase, 60Hz				
Cooling Capacity *1	Btu/h		15,000	18,000	24,000	27,000	30,000
Heating Capacity *1	Btu/h		17,000	20,000	27,000	30,000	34,000
Power Consumption	Cooling	W	188/207	188/207	245/270	270/297	326/360
	Heating	W	188/207	188/207	245/270	270/297	326/360
Current	Cooling	A	0.96/1.06	0.96/1.06	1.25/1.38	1.37/1.51	1.66/1.83
	Heating	A	0.96/1.06	0.96/1.06	1.25/1.38	1.37/1.51	1.66/1.83
External Finish			Unit: Galvanized Steel Plate				
Dimensions	Height	Inches	14-31/32	14-31/32	14-31/32	14-31/32	14-31/32
	Width	Inches	29-17/32	29-17/32	29-17/32	39-3/8	39-3/8
	Depth	Inches	35-7/16	35-7/16	35-7/16	35-7/16	35-7/16
Net Weight	Unit	Pounds	98	100	100	111	111
Heat Exchanger			Cross Fin (Aluminum Plate Fin and Copper Tube)				
Fan	Type x Quantity		Sirocco Fan x 1	Sirocco Fan x 1	Sirocco Fan x 1	Sirocco Fan x 1	Sirocco Fan x 1
	Airflow Rate *2	CFM	353-494	353-494	477-671	547-777	636-883
	Ext. Static Pressure (206/230V)	In. WG	0.201-0.642/0.401-0.602-0.803				
	Motor Type		Single-phase Induction Motor				
	Motor Output	W	130	130	180	220	230
Air Filter			Optional Part				
Refrigerant Pipe Dimensions	Low Pressure	Inches	1/2 (Flare)	1/2 (Flare)	5/8 (Flare)	5/8 (Flare)	5/8 (Flare)
	High Pressure	Inches	1/4 (Flare)	1/4 (Flare)	3/8 (Flare)	3/8 (Flare)	3/8 (Flare)
Drainpipe Dimension		Inches	O.D. 1-1/4	O.D. 1-1/4	O.D. 1-1/4	O.D. 1-1/4	O.D. 1-1/4
Sound Levels *2 (Low-High)		dB(A) @ 230V	34-39	34-39	36-41	35-41	38-43

Model Name			PEFY-P36NMHU-E	PEFY-P48NMHU-E	PEFY-P54NMHU-E	PEFY-P72NMHU-E	PEFY-P96NMHU-E
Power Source			208/230V, 1-phase, 60Hz			208/230V, 3-phase, 60Hz	
Cooling Capacity *1	Btu/h		36,000	48,000	54,000	72,000	96,000
Heating Capacity *1	Btu/h		40,000	54,000	60,000	80,000	108,000
Power Consumption	Cooling	W	683/754	683/754	695/767	1,352/1,495	1,690/1,870
	Heating	W	683/754	683/754	695/767	1,352/1,495	1,690/1,870
Current	Cooling	A	3.38/3.73	3.38/3.73	3.43/3.78	4.48/4.94	5.69/6.28
	Heating	A	3.38/3.73	3.38/3.73	3.43/3.78	4.48/4.94	5.69/6.28
External Finish			Unit: Galvanized Steel Plate				
Dimensions	Height	Inches	14-31/32	14-31/32	14-31/32	18-17/32	18-17/32
	Width	Inches	47-1/4	47-1/4	47-1/4	49-7/32	49-7/32
	Depth	Inches	35-7/16	35-7/16	35-7/16	44-1/8	44-1/8
Net Weight	Unit	Pounds	155	155	155	221	221
Heat Exchanger			Cross Fin (Aluminum Plate Fin and Copper Tube)				
Fan	Type x Quantity		Sirocco Fan x 2	Sirocco Fan x 2	Sirocco Fan x 2	Sirocco Fan x 2	Sirocco Fan x 2
	Airflow Rate *2	CFM	936-1,342	936-1,342	989-1,412	2,048	2,541
	Ext. Static Pressure (206/230V)	In. WG	0.201-0.642/0.401-0.602-0.803			0.28-0.642/0.40-0.80	
	Motor Type		Single-phase Induction Motor			Three-phase Induction Motor	
	Motor Output	W	400	400	400	650	850
Air Filter			Optional Part				
Refrigerant Pipe Dimensions	Low Pressure	Inches	5/8 (Flare)	5/8 (Flare)	5/8 (Flare)	3/4 (Braze)	7/8 (Braze)
	High Pressure	Inches	3/8 (Flare)	3/8 (Flare)	3/8 (Flare)	3/8 (Braze)	3/8 (Braze)
Drainpipe Dimension		Inches	O.D. 1-1/4	O.D. 1-1/4	O.D. 1-1/4	O.D. 1-1/4	O.D. 1-1/4
Sound Levels *2 (Low-High)		dB(A) @ 230V	38-44	38-44	38-44	47	54

**Note:** \*1 Cooling/Heating capacity indicates the maximum value at operation under the following conditions:  
 Cooling: Indoor: 80°F (27°C) DB/67°F (19°C) WB; Outdoor: 95°F (35°C) DB  
 Heating: Indoor: 70°F (21°C) DB; Outdoor: 47°F (8°C) DB/43°F (6°C) WB

\*2 Airflow rate/sound levels are at (Low-High)

Ventilation Air: Providing sufficient ventilation air is an important part of every building design. ASHRAE standard 62 provides the minimum ventilation air requirements. Also check local codes.

Specifications are subject to change.

# PEFY-P-NMLU-E SPECIFICATIONS

LOW PROFILE

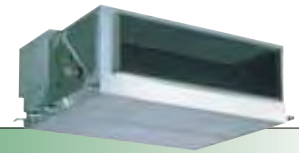

PEFY-P-NMLU-E Specifications					
Model Name			PEFY-P06NMLU-E	PEFY-P08NMLU-E	PEFY-P12NMLU-E
Power Source			208/230V, 1-phase, 60Hz		
Cooling Capacity *1		Btu/h	6,000	8,000	12,000
Heating Capacity *1		Btu/h	6,700	9,000	13,500
Power Consumption	Cooling	W	72/78	72/78	107/117
	Heating	W	72/78	72/78	107/117
Current	Cooling	A	0.37/0.40	0.37/0.40	0.54/0.59
	Heating	A	0.37/0.40	0.37/0.40	0.54/0.59
External Finish			Unit: Galvanized Steel Plate		
Dimensions	Height	Inches	8-7/8	8-7/8	8-7/8
	Width	Inches	31-1/8	31-1/8	31-1/8
	Depth	Inches	21-21/32	21-21/32	21-21/32
Net Weight	Unit	Pounds	40	40	40
Heat Exchanger			Cross Fin (Aluminum Plate Fin and Copper Tube)		
Fan	Type x Quantity		Sirocco Fan x 1		
	Airflow Rate *2	CFM	169-205-279	169-205-279	169-205-335
	External Static Pressure (230V)	In. WG	0.02	0.02	0.02
	Motor Type		Single-phase Induction Motor		
	Motor Output	W	23	23	32
Air Filter			Standard Filter		
Refrigerant Pipe	Low Pressure (Brazed)	Inches	1/2	1/2	1/2
	High Pressure (Brazed)	Inches	1/4	1/4	1/4
Drainpipe Dimension		Inches	O.D. 1-11/32		
Sound Levels *2	(Low-Mid-High) @ 230V	dB(A)	25-29-36	25-29-36	25-29-40

**Note:** \*1 Cooling / Heating capacity indicates the maximum value at operation under the following conditions:  
 Cooling: Indoor: 80°F (27°C) DB / 67°F (19°C) WB; Outdoor: 95°F (35°C) DB  
 Heating: Indoor: 70°F (21°C) DB; Outdoor: 47°F (8°C) DB / 43°F (6°C) WB

\*2 Airflow rate / sound levels are at (Low-Mid-High)

Ventilation Air: Providing sufficient ventilation air is an important part of every building design. ASHRAE standard 62 provides the minimum ventilation air requirements. Also check local codes.

**Specifications are subject to change.**



FLOOR-STANDING

# PFFY

Effective use  
of perimeter space.



**Exposed Type  
PFFY-P-NEMU-E**



**Concealed Type  
PFFY-P-NRMU-E**

Compact unit provides simple, effective air conditioning in perimeter zones. Less than 9 inches deep, these PFFY floor-standing units are easy to install in peripheral spaces, yet offer highly efficient air-conditioning performance. Since these are floor-standing models, they are perfect for spaces with little or no ceiling space. Their low operating sound and compact size make them ideal for hotel rooms. The PFFY offers tremendous flexibility in two distinct versions. The PFFY-NEMU exposed-type model is perfect for most applications and requires no finish work. The PFFY-NRMU is designed for applications requiring a built-in, concealed, floor-standing unit. Both types are available in six capacities: 6,000, 8,000, 12,000, 15,000, 18,000, and 24,000 Btu/h.

Optional mounting for remote controller. PFFY units can house either a Deluxe MA or ME Remote Controller in the top corner (under a cover panel). Thus, the remote controller can be mounted on the wall or in the PFFY unit.

## PFFY-NEMU Dimensions

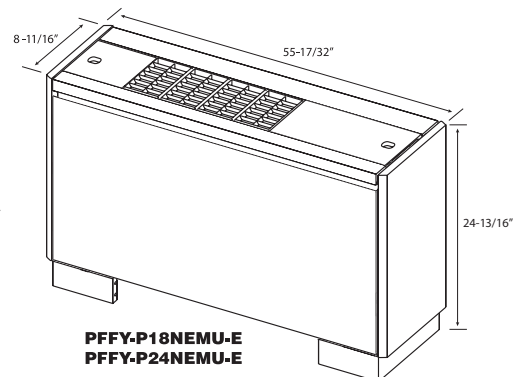
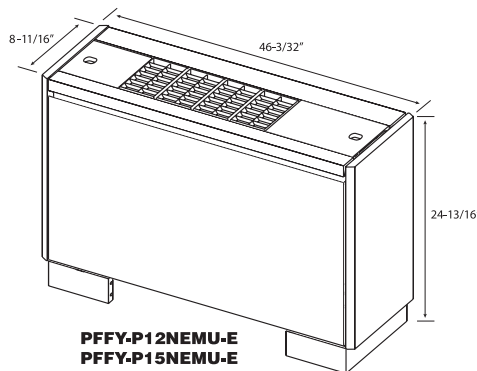
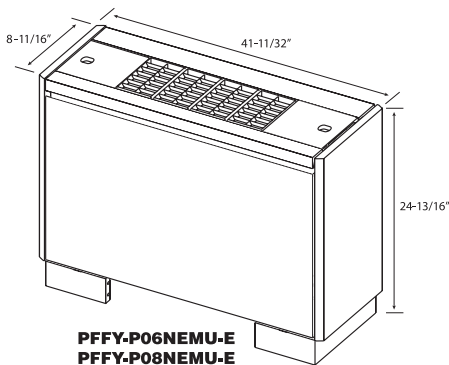

# PFFY-P-NEMU/NRMU-E SPECIFICATIONS

PFFY-P-NEMU-E



PFFY-P-NEMU-E Specifications								
Model Name			PFFY-P06NEMU-E	PFFY-P08NEMU-E	PFFY-P12NEMU-E	PFFY-P15NEMU-E	PFFY-P18NEMU-E	PFFY-P24NEMU-E
Power Source			208/230V, 1-phase, 60Hz					
Cooling Capacity *1		Btu/h	6,000	8,000	12,000	15,000	18,000	24,000
Heating Capacity *1		Btu/h	6,700	9,000	13,500	17,000	20,000	27,000
Power Consumption	Cooling	W	51/61	51/61	55/67	65/78	78/93	96/114
	Heating	W	51/61	51/61	55/67	65/78	78/93	96/114
Current	Cooling	A	0.25/0.27	0.25/0.27	0.27/0.30	0.32/0.35	0.38/0.42	0.47/0.51
	Heating	A	0.25/0.27	0.25/0.27	0.27/0.30	0.32/0.35	0.38/0.42	0.47/0.51
External Finish			Acrylic Painted Munsell (5Y 8/1)					
Dimensions	Height	Inches	24-13/16	24-13/16	24-13/16	24-13/16	24-13/16	24-13/16
	Width	Inches	41-11/32	41-11/32	46-3/32	46-3/32	55-17/32	55-17/32
	Depth	Inches	8-11/16	8-11/16	8-11/16	8-11/16	8-11/16	8-11/16
Net Weight	Unit	Pounds	51	51	56	58	67	71
Heat Exchanger			Cross Fin (Aluminum Plate Fin and Copper Tube)					
Fan	Type x Quantity		Sirocco Fan x 1	Sirocco Fan x 1	Sirocco Fan x 2	Sirocco Fan x 2	Sirocco Fan x 2	Sirocco Fan x 2
	Airflow Rate *2	CFM	194-229	194-229	247-317	300-388	353-459	353-494
	Motor Type		Single-Phase Induction Motor					
	Motor Output	W	15	15	18	30	35	63
Air Filter			Standard Filter					
Refrigerant Pipe Dimensions	Low Pressure (Flare)	Inches	1/2	1/2	1/2	1/2	1/2	5/8
	High Pressure (Flare)	Inches	1/4	1/4	1/4	1/4	1/4	3/8
Drainpipe Dimension		Inches	O.D. 1-1/32					
Sound Levels *2 (Low-High)		dB(A)	36-41	36-41	37-41	38-43	38-43	40-46

**Note:** \*1 Cooling / Heating capacity indicates the maximum value at operation under the following conditions:  
 Cooling: Indoor: 80°F (27°C) DB / 67°F (19°C) WB; Outdoor: 95°F (35°C) DB  
 Heating: Indoor: 70°F (21°C) DB; Outdoor: 47°F (8°C) DB / 43°F (6°C) WB

\*2 Airflow rate / sound levels are at (Low-High)

Ventilation Air: Providing sufficient ventilation air is an important part of every building design.  
 ASHRAE standard 62 provides the minimum ventilation air requirements. Also check local codes.

Specifications are subject to change.

PFFY-P-NRMU-E



PFFY-P-NRMU-E Specifications								
Model Name			PFFY-P06NRMU-E	PFFY-P08NRMU-E	PFFY-P12NRMU-E	PFFY-P15NRMU-E	PFFY-P18NRMU-E	PFFY-P24NRMU-E
Power Source			208/230V, 1-phase, 60Hz					
Cooling Capacity *1		Btu/h	6,000	8,000	12,000	15,000	18,000	24,000
Heating Capacity *1		Btu/h	6,700	9,000	13,500	17,000	20,000	27,000
Power Consumption	Cooling	W	51/61	51/61	55/67	65/78	78/93	96/114
	Heating	W	51/61	51/61	55/67	65/78	78/93	96/114
Current	Cooling	A	0.25/0.27	0.25/0.27	0.27/0.30	0.32/0.35	0.38/0.42	0.47/0.51
	Heating	A	0.25/0.27	0.25/0.27	0.27/0.30	0.32/0.35	0.38/0.42	0.47/0.51
External Finish			Galvanized Sheet Metal					
Dimensions	Height	Inches	25-3/16	25-3/16	25-3/16	25-3/16	25-3/16	25-3/16
	Width	Inches	34-29/32	34-29/32	39-5/8	39-5/8	49-1/16	49-1/16
	Depth	Inches	8-11/16	8-11/16	8-11/16	8-11/16	8-11/16	8-11/16
Net Weight	Unit	Pounds	41	41	45	47	56	60
Heat Exchanger			Cross Fin (Aluminum Plate Fin and Copper Tube)					
Fan	Type x Quantity		Sirocco Fan x 1	Sirocco Fan x 1	Sirocco Fan x 2	Sirocco Fan x 2	Sirocco Fan x 2	Sirocco Fan x 2
	Airflow Rate *2	CFM	194-229	194-229	247-317	300-388	353-459	353-494
	Motor Type		Single-Phase Induction Motor					
	Motor Output	W	15	15	18	30	35	63
Air Filter			Standard Filter					
Refrigerant Pipe Dimensions	Low Pressure (Flare)	Inches	1/2	1/2	1/2	1/2	1/2	5/8
	High Pressure (Flare)	Inches	1/4	1/4	1/4	1/4	1/4	3/8
Drainpipe Dimension		Inches	O.D. 1-1/32					
Sound Levels *2 (Low-High)		dB(A)	36-41	36-41	37-41	38-43	38-43	40-46

**Note:** \*1 Cooling / Heating capacity indicates the maximum value at operation under the following conditions:  
 Cooling: Indoor: 80°F (27°C) DB / 67°F (19°C) WB; Outdoor: 95°F (35°C) DB  
 Heating: Indoor: 70°F (21°C) DB; Outdoor: 47°F (8°C) DB / 43°F (6°C) WB

\*2 Airflow rate / sound levels are at (Low-High)

Ventilation Air: Providing sufficient ventilation air is an important part of every building design.  
 ASHRAE standard 62 provides the minimum ventilation air requirements. Also check local codes.

Specifications are subject to change.

## Our CITY MULTI® Controls Network makes it **easy to manage** your building.

The CITY MULTI Controls Network (CMCN) manages up to **2,000 indoor units** from a single network PC in terms of operation, monitoring, scheduling (daily, weekly, and yearly), error email, personal browser, tenant billing, and maintenance diagnostic information. The CMCN puts individual, personalized comfort in the hands of the tenants and the building manager.

### Flexible design for customized, individual zone control

Building owners and engineers can select from a wide variety of remote controllers and timers to satisfy the exact level of tenant control on a zone-by-zone basis, while providing the ultimate in individualized control. Each indoor unit may have one or two remote controllers or none at all.

The remote controllers allow the temperature setpoint to be changed along with On/Off control and fan speed adjustment. Mode selection (Cool/Heat/Dry/Fan/Auto) and vane control are also possible, depending on the remote controller.

The CMCN enables the room temperature to be sensed either at the remote controller in the zone *or* the temperature to be sensed at the actual indoor unit simply by changing the dip switch setting on the indoor unit. Depending on the type of the remote controller, the remote controller can be physically located in the controlled zone *or* in a physical location different than the controlled zone to meet the customer's specific requirements.

The versatility of the CMCN customizes each building's controls network to address the specific design and tenant requirements, while providing unparalleled comfort conditioning.

### Easy installation

It's a simple, two-pipe system with simple, non-polar, two-wire control connections. All components are *daisy-chained* and addressed onto the M-NET communication bus. It all adds up to less labor and materials with quicker installation.

### Optional easy-to-use control via PC web browser

With the CMCN, you have the option to control multiple CITY MULTI systems with the G-50A/GB-50A Centralized Controller(s) from a PC's web browser. From Internet Explorer® on a PC, the building manager can now monitor, operate, and schedule (daily, weekly, and yearly) the HVAC system through the G-50A/GB-50A network. Emails can be automatically generated when an abnormal condition is detected on the system with the source address and the error code. In addition, the building manager can enable tenants to control their own individual zones via the web browser on their networked PC.

### Single-source control for up to 2,000 indoor units

From a single network PC configured with our TG-2000 software, you can control up to 2,000 units. Our TG-2000 integrated system software provides the ultimate in building management by allowing input of the building's floor plan with illustrative icons for the CITY MULTI indoor units. This software, in conjunction with a maximum of 40 G-50A/GB-50A Centralized Controllers, empowers the building manager to control the HVAC system for multiple buildings in a business park, educational campus, or retirement facility.

### Tenant billing

The TG-2000 software configured with the tenant billing option and interconnected with RS-485 watt-hour meter(s) can calculate the energy consumption relative to each outdoor unit on a per-tenant basis and generate a per-tenant CITY MULTI energy bill.

### System integration

Not only can our CMCN act as a stand-alone building management system; it can also integrate with existing systems via LonWorks® or BACnet® interfaces.

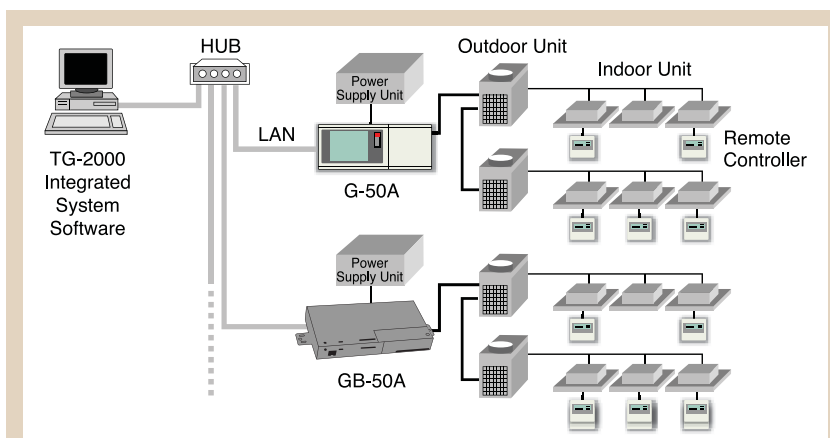

*TG-2000 software manages up to **2,000 indoor units**  
with a maximum of 40 G-50A/GB-50A centralized controllers  
with software licenses.*

# CITY MULTI® Controls Network Specifications

Model	Remote Controllers			Timers	System Controller	BMS/EMS					
	Deluxe MA	ME	Simple MA	Schedule Timer	On/Off Controller	Centralized Control			Integrated System Software		
	PAR-21MAA	PAR-F27MEA	PAC-YT51CRB	PAC-YT34STA	PAC-YT40ANRA	G-50A		GB-50A		TG-2000	
No. of units controllable (Groups (G) / units)	1G/16units	1G/16units	1G/16units	50G/50units	16G/50 units	50G/50units G-50A   Browser *4		50G/50units GB-50A   Browser *4		*7 2000G/2000 units	
Operation	On / Off	○	○	○	⊙	⊙	⊙	⊙	▲	⊙	⊙
	Operation mode	○	○	○	N/A	N/A	⊙	⊙	N/A	⊙	⊙
	Temperature Setting	○	○	○	N/A	N/A	⊙	⊙	N/A	⊙	⊙
	Local Permit / Prohibit	N/A	N/A	N/A	⊙	N/A	⊙	⊙	N/A	⊙	⊙
	Fan speed	○	○	○	N/A	N/A	⊙	⊙	N/A	⊙	⊙
	Airflow direction	○	○	N/A	N/A	N/A	⊙	⊙	N/A	⊙	⊙
Monitoring	On / Off	○	○	○	⊙	⊙	○	▲	○	⊙	○
	Operation mode	○	○	○	N/A	N/A	○	○	N/A	○	○
	Set temperature	○	○	○	N/A	N/A	○	○	N/A	○	○
	Local Permit / Prohibit	○	○	○	○	⊙	○	○	N/A	○	○
	Fan speed	○	○	○	N/A	N/A	○	○	N/A	○	○
	Airflow direction	○	○	N/A	N/A	N/A	○	○	N/A	○	○
	Indoor temperature (intake)	○	○	N/A	N/A	N/A	○	○	N/A	○	○
	Filter sign	○	○	N/A	N/A	N/A	○	○	N/A	○	○
Error	Error flashing	○	○	○	○	○	○	▲	○	○	○
	Error code	○	○	○	○	○	○	○	N/A	○	○
	Operating time	N/A	N/A	N/A	N/A	N/A	N/A	N/A	N/A	N/A	●
Scheduling	One day	○	○	N/A	N/A	N/A	N/A	●	N/A	●	●
	Times of stops / starts per day	8	*2 / 1 / 48 *1	N/A	16	N/A	3/3	12	N/A	12	12
	Weekly	○	N/A / ○ *1	N/A	○	N/A	○	●	N/A	●	●
	Times of stops / starts per week	8 x 7	N/A	N/A	16 x 7	N/A	21/21	12 x 7	N/A	12 x 7	12 x 7
	Annual (Designated day setting)	N/A	○	N/A	N/A	N/A	N/A	●	N/A	●	●
	Auto OFF timer	○	○	N/A	N/A	N/A	N/A	N/A	N/A	N/A	N/A
	Minimum setting unit (minutes)	1	10/30 *1	N/A	5	N/A	10	1	N/A	1	1
Recording	Error history	N/A	N/A	N/A	N/A	N/A	○	○	N/A	○	○
	Daily / Monthly reports	N/A	N/A	N/A	N/A	N/A	N/A	N/A	N/A	N/A	○
	Electricity charges	N/A	N/A	N/A	N/A	N/A	N/A	N/A	N/A	N/A	●
Others	Set temperature range limit	○	○	○	N/A	N/A	N/A	○ *2	N/A	○ *2	○ *6
	Auto lock	○	○	N/A	N/A	N/A	N/A	N/A	N/A	N/A	N/A
Control and management	Ventilation (group / interlocked)	N/A / ○	N/A / ○	N/A / ○	○	○	○	○ / ○ *5	N/A	○ / ○ *5	○ / ○
	Group setting	○ *3	○	○ *3	○	○	○	○ *5	N/A	○ *5	○
	Block setting	N/A	N/A	N/A	N/A	N/A	N/A	○ *5	N/A	○ *5	○
	Revision of electricity charges	N/A	N/A	N/A	N/A	N/A	N/A	N/A	N/A	N/A	● ■
Operation Lossnay (group / interlocked)	Start / Stop	N/A / ○	N/A / ○	N/A / ○	⊙ / ○	⊙ / ○ *8	⊙ / ○	⊙ / ○	▲ / ▲	⊙ / ○	⊙ / ○
	Fan speed	N/A / ○	N/A / ○	N/A / N/A	N/A	N/A	⊙ / ○	⊙ / ○	N/A / N/A	⊙ / ○	⊙ / ○
	Ventilation mode	N/A / N/A	N/A / N/A	N/A / N/A	N/A	N/A	⊙ / N/A	⊙ / N/A	N/A / N/A	⊙ / N/A	○ / N/A
Monitoring Lossnay (group / interlocked)	Status	N/A / ○	N/A / ○	N/A / ○	○ / ○	N/A	⊙ / ○	⊙ / ○	▲ / ▲	⊙ / ○	⊙ / ○
	Fan speed	N/A / ○	N/A / ○	N/A	N/A	N/A	○ / ○	○ / ○	N/A / N/A	○ / ○	○ / ○
	Ventilation mode	N/A	N/A	N/A	N/A	N/A	○ / N/A	○ / N/A	N/A / N/A	○ / N/A	○ / N/A

○: Each group / batch    ○: Each group    □: Depends on the building management system    ■: Block (CITY MULTI indoor unit only)  
 ▲: Set up by a local remote controller    △: Please inquire    N/A: Not available    -: Not used    ●: Requires G-50A / GB-50A software license

\*1: When PAC-YT32PTA is connected.    \*2: Daily timer availability    \*3: For group operation cross-over wiring is required between indoor units.  
 \*4: Requires software licenses per G-50A / GB-50A.    \*5: Installation possible with Initial Setting Browser.    \*6: Ver. 4.10 or more.  
 \*7: Web monitoring and web scheduling licenses are required per G-50A / GB-50A.    \*8: Inter-lock is set at Local remote controller.



# CITY MULTI® Controllers

## Deluxe MA Remote Controller (PAR-21MAA)

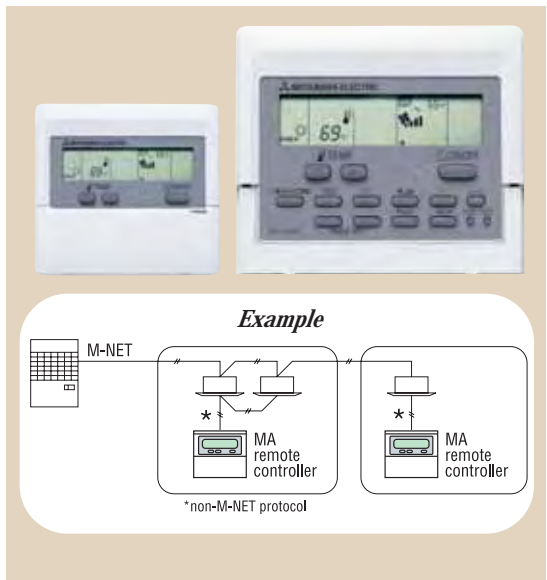

- **Features user-friendly** multilingual operation and monitoring.
- **Controls up to 16 indoor units in a single group.**
- **User Functions:** Allows user to set:
  - On/Off
  - operation modes of Cool, Heat, Dry, Fan, or Auto (R2-Series only)
  - set temperature from 57°F – 87°F, dependent on operation mode and indoor unit
  - fan speed setting
  - airflow direction
- **Timer Operation:** Supports Weekly Timer operation (On/Off/Set Temperature). Supports Auto-Off Timer.
- **Room Temperature:** Displays room temperature sensed either at the Remote Controller or at the indoor unit.
- **Set Temperature Range Limit:** Reduces the allowable set temperature range in Cool or Heat modes from Remote Controller.
- **Function Lock Out:** Prohibits all functions or all functions except On/Off.
- **Diagnostics:** Displays four-digit error code.
- **Grouping:** Can only be used in same group with other PAR-21MAA Deluxe MA Remote Controllers and PAC-YT51CRA Simple MA remote controllers, with up to two remote controllers per group.
- **Addressing:** No addressing required.
- **Wiring:** Connects using two-wire, stranded, non-polar control wire to TB15 connection terminal on the indoor unit. Requires cross-over wiring for grouping across indoor units.
- **Dimensions:** 5-1/8" x 3/4" x 4-3/4"

## ME Remote Controller (PAR-F27MEA)

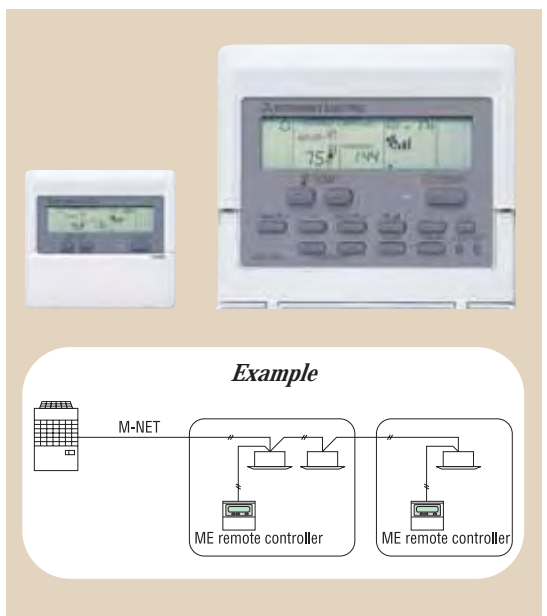

- **Features user-friendly** operation and monitoring.
- **Controls up to 16 indoor units in a single group.**
- **User Functions:** Allows user to set:
  - On/Off
  - operation modes of Cool, Heat, Dry, Fan, or Auto (R2-Series only)
  - set temperature from 57°F – 87°F, dependent on operation mode and indoor unit
  - fan speed setting
  - airflow direction
- **Timer Operation:** Supports repeated daily timer operation of one On/Off setting repeated every day and an Auto-off timer.
- **Room Temperature:** Displays room temperature sensed either at the Remote Controller or at the indoor unit.
- **Set Temperature Range Limit:** Reduces the allowable set temperature range in Cool or Heat modes from Remote Controller or PC.
- **Function Lock-Out:** Prohibits all functions or all functions except On/Off.
- **Diagnostics:** Displays four-digit error code and error unit address.
- **Grouping:** Can be used only in same group with a total of two PAR-F27MEA (ME Remote Controllers) per group.
- **Addressing:** Requires manual addressing using rotary dial switch to the M-NET communication bus.
- **Wiring:** Connects using two stranded, non-polar control wires to TB5 connection terminal on the indoor unit.
- **Dimensions:** 5-1/8" x 3/4" x 4-3/4"

## Simple MA Remote Controller (PAC-YT51CRB)



- **Features user-friendly** operation and monitoring.
- **Controls up to 16 indoor units in a single group.**
- **User Functions:** Allows user to set:
  - On/Off
  - operation modes of Cool, Heat, Dry, Fan, Auto (R2-Series only), Ventilation
  - fan speed setting
  - set temperature from 57°F - 87°F, dependent on operation mode and indoor unit
- **Grouping:** Can be used only in same group with other PAC-YT51 (Simple MA Remote Controller) and PAR-21MAA (Deluxe MA Remote Controller) with up to two remote controllers per group.
- **Addressing:** No addressing required.
- **Set Temperature Range Limit:** Reduces the allowable set temperature range in Cool or Heat modes from Remote Controller.
- **Diagnostics:** Displays four-digit error code and error unit address.
- **Wiring:** Connects using two stranded, non-polar control wires to TB15 connection terminal on the indoor unit. Requires crossover wiring for grouping across indoor units.
- **Dimensions:** 2-3/4" x 1-5/8" x 4-3/4"

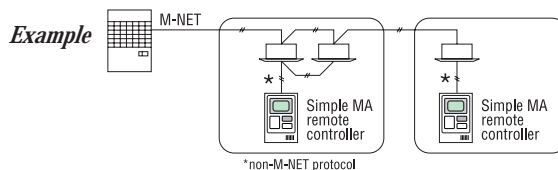

## On/Off Controller (PAC-YT40ANRA)



- **On/Off Control** for up to 16 Groups (max. of 50 indoor units).
- **Collective On/Off Button** turns all units on/off. Collective LED displays if any units are on, off, or in error.
- **Individual On/Off Button** for 16 groups of indoor units. Turns individual group on/off. Individual LED displays if any units in the group are on, off, or in error.
- **Diagnostics:** Flashing LED indicates error.
- **Addressing:** Requires manual addressing using rotary dial switch to the M-NET communication bus (default address is 201).
- **Wiring:** Connects to TB7 connection terminal on outdoor unit via PAC-SC50KUA power supply or connects to TB3 connection terminal on outdoor unit.
- **Dimensions:** 5-1/8" x 3/4" x 4-3/4"
- **Recommended** to be used in conjunction with PAR-21MAA Deluxe MA Remote Controllers or PAR-F27MEA ME Remote Controllers for temperature and mode setting.
- **Expandability:** External input signal can be used for batch operation such as Emergency Stop, On/Off, or On/Off plus prohibit of local remote controller operation. External output signal for collective operation state or error state.

## Schedule Timer (PAC-YT34STA)



- **Schedules up to 50 indoor units.** Maximum number of indoor units per one group is 16. Maximum number of groups is 50.
- **Use only in conjunction** with PAR-21MAA (Deluxe MA Remote Controllers) or PAR-F27MEA (ME Remote Controllers).
- **Scheduling:** Supports up to nine patterns with up to 16 operations per pattern. Operations include On/Off, mode selection (Cool, Heat), set temperature, and prohibition of remote controller functions (On/Off, operation mode change, and set temperature adjustment). Patterns are applied to each group of indoor units on a per-day basis. Minimum time interval is 5 minutes.
- **Diagnostics:** Displays four-digit error code and error unit address.
- **Addressing:** Requires manual addressing using rotary dial switch to the M-NET communication bus.
- **Wiring:** Connects to TB7 connection terminal on outdoor unit with the PAC-SC50KUA power supply or connects to TB3 connection terminal on outdoor unit.
- **Dimensions:** 5-1/8" x 3/4" x 4-3/4"
- **Expandability:** Can be used in conjunction with G-50A Centralized Controller, which has higher priority but requires change in dip-switch setting. Can be used in conjunction with external input/output signals.

## G-50A Centralized Controller



- **Manages up to 50 indoor units** in terms of monitoring, operation, scheduling (daily/weekly), and maintenance diagnostics. Units can be controlled individually, in a group, or in a collective batch operation.
  - **Controls On/Off,** operation mode selection (Cool, Heat, Auto, Dry, Fan), Temperature Setting, and Airflow Direction.
- **Permits or prohibits remote controller functions** such as On/Off, Change Operation Mode, and Set Temperature.
- **Scheduling:** Supports daily schedule (three On/Off settings) and weekly schedule (21 On/Off settings per week). Schedule functionality is expanded to 12 settings per day and 84 settings per week when licensed for operation via PC.
- **Set-back:** Programs the setback temperature by 0°F – 18°F.
- **Diagnostics:** Displays four-digit error code and error unit address for up to 50 units.
- **Addressing:** Requires manual addressing using rotary dial switch to the M-NET communication bus. Default address is 000.
- **Wiring:** Requires Power Supply unit (PAC-SC50KUA) that supplies 12 V DC.
- **Dimensions:** 11-13/16" x 3-1/8" x 4-3/4"
- **Expandability:** RJ-45 Ethernet port supports optional interconnection directly to PC or to Local Area Network (LAN). PC browser functions and TG-2000 software functions require Mitsubishi Electric HVAC-issued software licenses for defined term. External input/output signals can be used for batch operations such as Start/Stop and Emergency Stop.

# CITY MULTI® G-50A and GB-50A Centralized Controllers

## G-50A Centralized Controller



## GB-50A Centralized Controller

The G-50A/GB-50A Centralized Controllers are capable of controlling a maximum of 50 indoor units across multiple CITY MULTI outdoor units. The G-50A is approximately 5" x 12" in size and the GB-50A is approximately 10" w x 5" h x 1.5" d. Both are powered from the power supply unit model PAC-SC50KUA.

The G-50A/GB-50A Centralized Controllers support operations that supersede control of the remote controllers and include system configuration, daily/weekly scheduling, operation, and malfunction monitoring. All G-50A/GB-50A Centralized Controllers are equipped with an RJ-45 Ethernet port to support optional interconnection with a networked PC via a closed/direct Local Area Network (LAN). Software functions are available so that the building manager can securely log into each G-50A/GB-50A via the PC's web browser to support operation monitoring, daily/weekly/yearly scheduling, error email distribution, personal browser, and maintenance diagnostics.

The G-50A software functions for the PC currently include web monitoring, web scheduling, error email, personal browser, and online maintenance tool. The optional software functions are licensed on a per G-50A basis for a one-year or three-year term by Mitsubishi Electric HVAC, subject to renewal and associated fees upon term expiration.

The GB-50A is perfect for building or facility managers who want to operate and monitor CITY MULTI equipment simply via a PC browser. The standard GB-50A software functions are: monitoring, scheduling, error email distribution (optional software functions include personal web browser), and online maintenance tool (non-expiring).

## Operation monitoring via PC web browser

This feature enables the building manager to easily monitor and operate all 50 units from the PC's browser.



## Scheduling via PC web browser

This function enables the building manager to customize daily, weekly, and yearly schedules for all 50 units. Schedules can be applied to a single unit, a group of units, or collectively (batch) to all units.

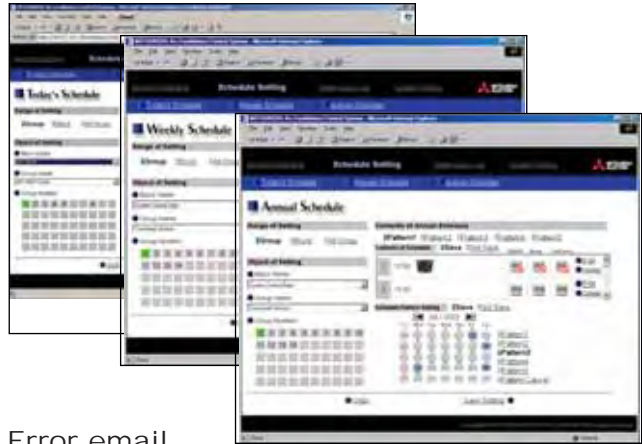

## Error email

If an error occurs on the CITY MULTI system monitored by the G-50A/GB-50A, the fault will be detected and isolated, and a detailed alert will be sent to the necessary personnel via real-time email. The user can then view and clear the error logs from the PC and use the information for troubleshooting.

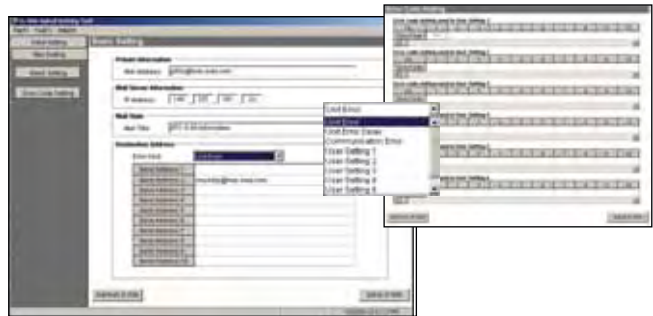

## Individual personal browser via PC web browser

This innovation allows individual users to control their zone conditioning via a personal networked PC with or without a remote controller.



## Online maintenance tool

This capability performs maintenance diagnostics via a network PC and G-50A/GB-50A Centralized Controller.





# TG-2000™ Integrated System Software

The TG-2000 integrated system software enables the user to control multiple G-50A/GB-50A controllers and provide enhanced functions from a single, dedicated networked PC configured with the TG-2000 software and G-50A/GB-50A software licenses. The TG-2000 configured PC is capable of controlling up to 40 G-50A/GB-50A Centralized Controllers with a maximum of 2,000 indoor units.

Additional software features are available through the TG-2000 software including

**tenant billing**. All software functions can be licensed for a one-year or three-year term, subject to renewal and associated fees upon term expiration.

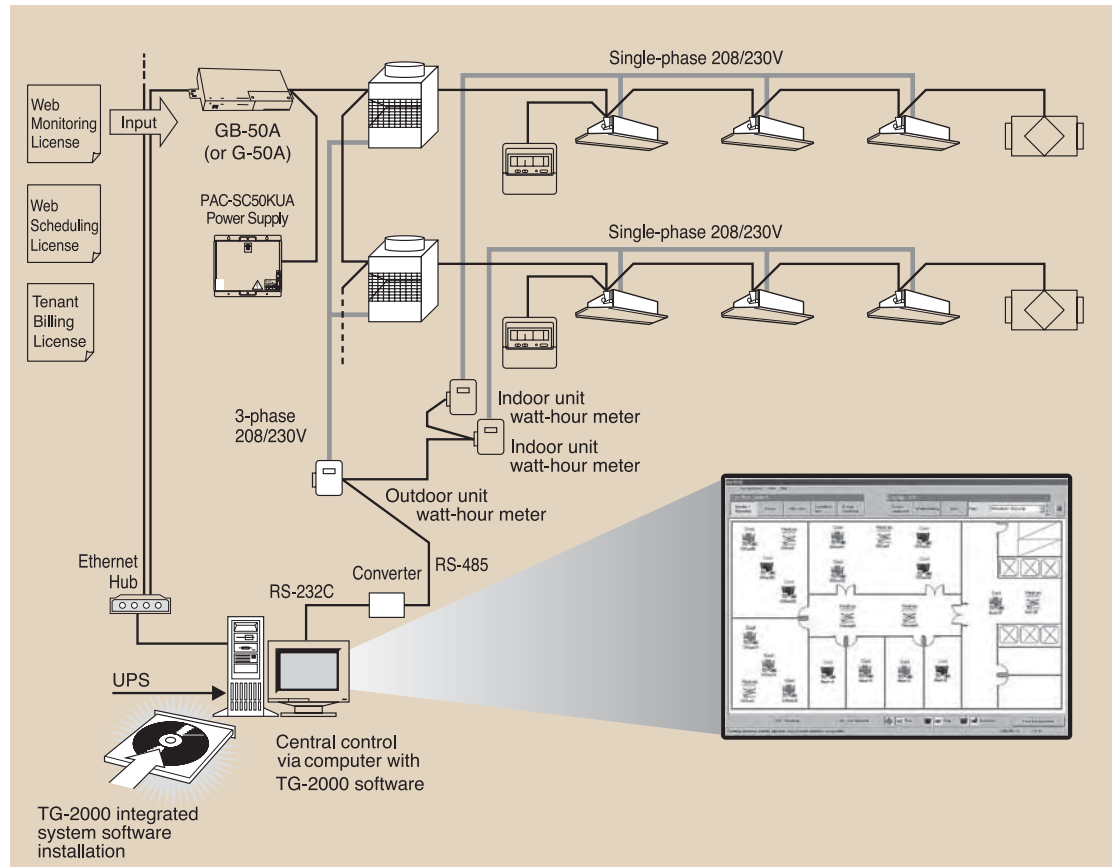

## Tenant billing

The tenant billing function of TG-2000 will output the HVAC energy consumption in kWh and monetary amount for the CITY MULTI outdoor unit(s) divided among defined blocks of indoor units. The tenant billing function requires that a RS-485 WHM monitor the energy consumption of one or more CITY MULTI outdoor units and be interconnected to the TG-2000 computer via a RS-485/RS-232C converter. The tenant billing output can be sent directly to a networked printer and/or to a destination folder on the TG-2000 PC as an Excel® file. This tenant billing output can then be input into an Excel-based support tool to generate an individual *HVAC Energy Bill* per tenant. The format of this *HVAC Energy Bill* can be customized.

## Screen Images





# System Integration: LonWorks® and BACnet®

The CMCN supports integration with Building Management Systems (BMS) via our LonWorks® and BACnet® interfaces.

## LonWorks®

The Mitsubishi Electric HVAC LonWorks® interface, LMAP03U, supports up to 50 indoor units with a variety of network variables on a per indoor unit basis. Input variables include but are not limited to On/Off, Operation Mode, Fan Speed, Prohibit Remote Controller, and Filter Sign Reset. Output variables include but are not limited to Model Size, Alarm State, Error Code, and Error Address.

## BACnet®

The Mitsubishi Electric HVAC BACnet interface, PAC-YG31CDA, is compliant with BACnet/IP (ANSI/ASHRAE 135-1995, 135a) and UDP/IP of Ethernet (ANSI/ASHRAE 135-1995, 135b). Our BACnet interface requires a dedicated network computer configured with the BACnet interface software and the BACnet software license per G-50A/GB-50A, licensed by Mitsubishi Electric HVAC. A maximum of 10 G-50A/GB-50A Centralized Controllers are supported via the BACnet PC for a maximum of 500 indoor units for BACnet integrations.

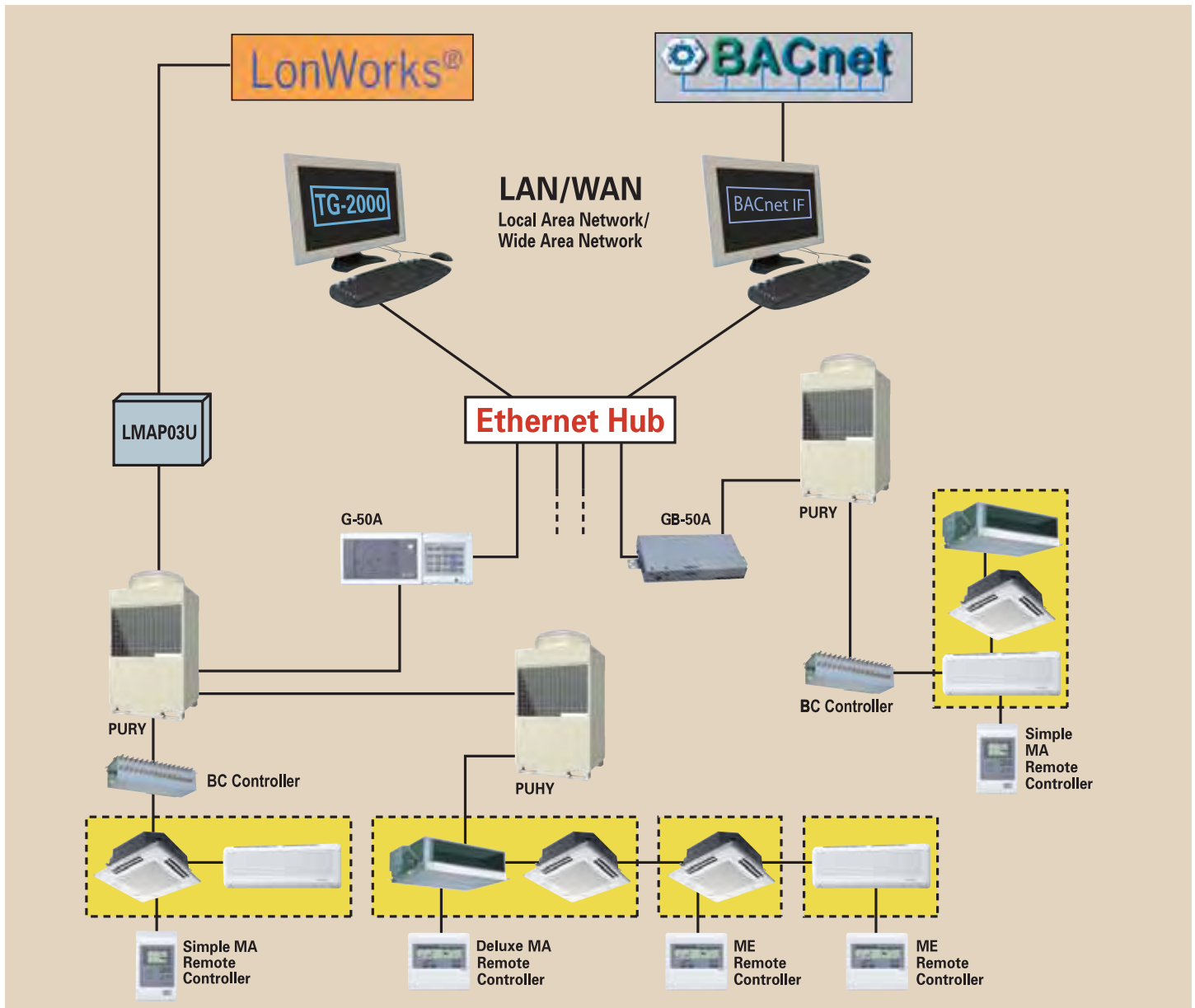

# LOSSNAY® ENERGY RECOVERY VENTILATORS

Lossnay® energy recovery ventilators provide **outdoor air solutions** for indoor environmental quality.



Model	CFM	Model	CFM
<b>LGH-F300RX3-E</b>	<b>300</b>	<b>LGH-F470RX3-E</b>	<b>470</b>
<b>LGH-F600RX3-E</b>	<b>600</b>	<b>LGH-F1200RX3-E</b>	<b>1,200</b>

Bypass auto ventilation standard  
Lossnay models offer three ventilation modes:

- Energy Recovery - Heat Exchange
- Bypass - No Exchange
- Automatic - Heat Exchange/Bypass

With conventional ERVs, bypass ventilation was impossible without attaching additional dampers and adapters. With the LGH-F-RX3-E series, however, this mode is available without the use of other parts. Additionally, automatic mode allows the system to select recovery or bypass as required. Mode selection is easy when interlocked with M-NET systems using the PZ-52SF remote controller, sold separately. When using Lossnay independently, the separately sold PZ-41SLB remote controller provides mode selection.

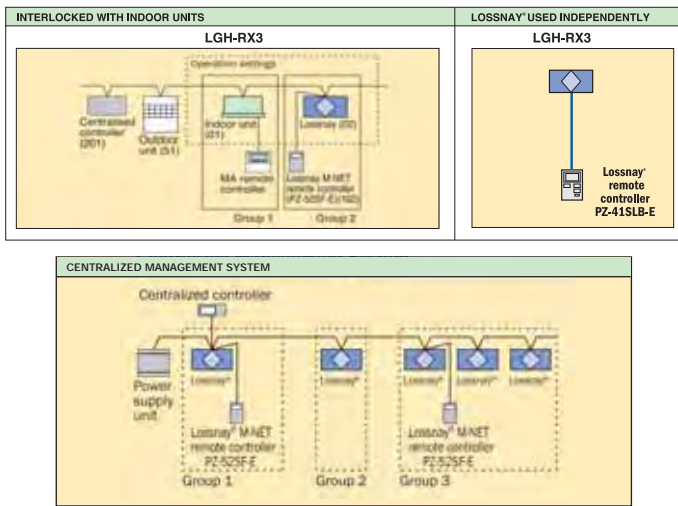

Mitsubishi Electric has responded to the growing need for total, integrated management of building HVAC and indoor air quality by making it easier to interlock and control Lossnay® energy recovery ventilators with our air-conditioning systems.

Improved sound attenuation makes Lossnay® units quiet enough for places where silence is a must, such as meeting rooms and libraries. A free-cooling function is standard to help reduce costs and boost efficiency. The integrated, bypass damper design makes installation and system management quick and efficient.

## Interlock simply, effectively, and economically

Because the M-NET adapter comes as standard equipment, networking systems connected with Mitsubishi Electric air conditioners has never been easier. There is no need to purchase additional parts. Systems can be assembled simply and logically, reducing construction times and keeping initial costs low.

## System compatibility

The LGH-F-RX3-E series is fully compatible with TG-2000 software, LMAP LonWorks® interface and BACnet® interface, further increasing the scope of total system management.

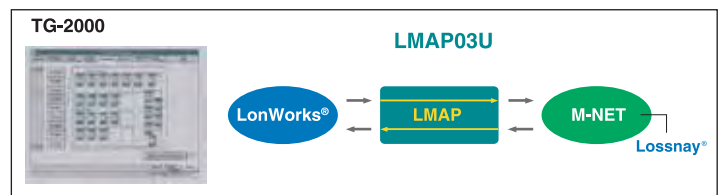

## Multi-function LCD remote controller

These ERV remote controllers are compact and attractive. In addition to controls for ON/OFF, Run mode, and Ventilation mode, the time period for filter maintenance is also displayed. The liquid crystal display has been designed for easy visibility. The Lossnay M-NET controller, model PZ-52SF-E, can control upto 16 Lossnay units in a single group.



See the Lossnay Technical Brochure for complete information.



Certificate Number FM33568

Mitsubishi Electric Air Conditioning & Refrigeration Systems Works acquired ISO 9001 certification under Series 9000 of the International Standard Organization (ISO), based on a review of quality warranties for the production of refrigeration and air conditioning equipment.

**ISO Authorization System**

The ISO 9000 series is a plant authorization system relating to quality warranties as stipulated by the ISO. ISO 9001 certifies quality warranties based on the "design, development, production, installation, and auxiliary services" for products built at an authorized plant.



Certificate Number EC97J1227

Mitsubishi Electric Air Conditioning & Refrigeration Systems Works acquired environmental management system standard ISO 14001 certification.

The ISO 14000 series is a set of standards applying to environmental protection set by the International Standard Organization (ISO).

See complete warranty for terms, conditions, and limitations. A copy is available from Mitsubishi Electric, 3400 Lawrenceville Suwanee Road, Suwanee, GA 30024



Mitsubishi Electric & Electronics USA, Inc.  
www.mehvac.com

CMTECH-07-07-20M