



# **INTEGRATED CE S BUS**

Sales Proposal For:

**Wolfington Body Co., Inc.**

Presented By:

**WOLFINGTON BODY CO INC**

---

**Prepared For:**

Wolffington Body Co., Inc.  
WOLFINGTON BODY COMPANY  
PO Box 218  
Exton, PA 19341-0218  
(610)458 - 8501  
Reference ID: 2022 54 GAS PKG

**Presented By:**

WOLFINGTON BODY CO INC  
Matt Prince  
P O BOX 218  
EXTON PA 19341  
610-458-8501

Thank you for the opportunity to provide you with the following quotation on a new IC Corporation vehicle. I am sure the following detailed specification will meet your operational requirements, and I look forward to serving your business needs.

**Model Profile**  
**2022 INTEGRATED CE S BUS (PB105)**

**APPLICATION:**

School Transportation

**MISSION:**

Requested GVWR: 29800. Calc. GVWR: 29800  
Calc. Start / Grade Ability: 25.05% / 1.82% @ 55 MPH  
Calc. Geared Speed: 80.1 MPH

**DIMENSION:**

Wheelbase: 254.00, CA: N/A, Axle to Frame: 143.00

**ENGINE, GASOLINE:**

{Power Solutions International 8.8 Liter GAS} EPA 2018, 265 HP @ 2600 RPM, 548 lb-ft Torque @ 1800 RPM, 2700 RPM Governed Speed, 265 Peak HP (MAX)

**TRANSMISSION, AUTOMATIC:**

{Allison 2550 PTS} 5th Generation Controls, Wide Ratio, 6-Speed with Double Overdrive, Less PTO Provision, Less Retarder, Includes Park Pawl, with 30,000-lb GVW and GCW Max, School Bus

**CLUTCH:**

Omit Item (Clutch & Control)

**AXLE, FRONT NON-DRIVING:**

{Meritor MFS-10-122A} I-Beam Type, 10,000-lb Capacity

**AXLE, REAR, SINGLE:**

{Dana Spicer 19060S} Single Reduction, 19,800-lb Capacity, 190 Wheel Ends Gear Ratio: 6.17

**TIRE, FRONT:**

(2) 10R22.5 Load Range G AH37 (HANKOOK), 517 rev/mile, 75 MPH, All-Position

**TIRE, REAR:**

(4) 10R22.5 Load Range G DH01 (HANKOOK), 512 rev/mile, 75 MPH, Drive

**SUSPENSION, REAR, SINGLE:**

19,800-lb Capacity, Two Stage Vari-Rate Springs

**PAINT:**

Cab schematic 100NB  
Location 1: 4421, School Bus Yellow (Std)  
Chassis schematic N/A

**Vehicle Specifications**  
**2022 INTEGRATED CE S BUS (PB105)**

**December 15, 2020**

<b>Code</b>	<b>Description</b>
PB10500	Base Chassis, Model INTEGRATED CE S BUS with 254.00 Wheelbase, N/A CA, and 143.00 Axle to Frame.
1570	TOW HOOK, FRONT (2) Frame Mounted
1CAC	FRAME RAILS High Strength Low Alloy Steel (50,000 PSI Yield); 10.125" x 3.062" x 0.312" (257.2mm x 77.8mm x 8.0mm); 480.1" (12195mm) Maximum OAL <u>Includes</u> : CHASSIS PAINT Chassis Painted Prior to Body Mounting : FRAME RAILS All holes Laser Aligned and Machine Punched, Powder Coated Prior to Full Assembly, Assembled in Fixture using "Grade 8" Bolts : FRAME REINFORCEMENT, SPECIAL 3.30" x 1.80" x 0.312" x 31.50" Inverted "L" in Front Shock Absorber Mounting Area
1LLE	BUMPER, FRONT Contoured, Steel, Severe Duty <u>Includes</u> : BUMPER, FRONT THICKNESS 1/4 Inch
1LMW	CROSSING GATE, FRONT Electric, Yellow Blade, Bumper Mounted <u>Includes</u> : CONTROL ASSEMBLY Solid State, Located Rear of Front Bumper, Heater not Required : CROSSING GATE, FRONT Matches Contour of Bumper
1SAL	CROSSMEMBER, REAR, AF (1)
1WHU	WHEELBASE RANGE 254" (645cm) Only
2ASH	AXLE, FRONT NON-DRIVING {Meritor MFS-10-122A} I-Beam Type, 10,000-lb Capacity <u>Includes</u> : AXLE, FRONT SQUARING to Plus or Minus .015 Inch, using a Special Fixture to Assure Parallelism of Springs <u>Notes</u> : The following features should be considered when calculating Front GAWR: Front Axles; Front Suspension; Brake System; Brakes, Front Air Cam; Wheels; Tires.
3ADB	SUSPENSION, FRONT, SPRING Parabolic Taper Leaf, Shackle Type, 10,000-lb Capacity, with Shock Absorbers <u>Includes</u> : SPRING PINS Bolt and Nut Type : SPRING PINS Rubber Bushings, Maintenance-Free <u>Notes</u> : The following features should be considered when calculating Front GAWR: Front Axles; Front Suspension; Brake System; Brakes, Front Air Cam; Wheels; Tires.
4100	BRAKE SYSTEM, HYDRAULIC {Wabco} Split System, with Automatic Adjustment and Four Channel ABS
4EVD	DUST SHIELDS, FRONT BRAKE for Hydraulic Brakes
4EVE	DUST SHIELDS, REAR BRAKE for Hydraulic Brakes
4GBJ	BRAKE, PARKING {Bosch} DSSA Type, 12" x 3"; for Hydraulic Brake Chassis; Foot Operated in Cab; Differential Mounted <u>Includes</u> : BRAKE, PARKING Foot Activated Parking Brake
4JNX	TRACTION CONTROL, HYDRAULIC Automatic; Hydraulic Brake System, with Electronic Stability Control
4WGT	PARKING BRAKE INTERLOCK Parking Brake Cannot be Released until Ignition Switch is in the "ON" Position and the Service Brake Pedal is Applied, Use with Hydraulic Brake Chassis Only
4WXP	GVWR LIMITATION FOR BUS with Hydraulic Brakes, Limited to 29,800-lbs Maximum to meet FMVSS 105 Requirements, for Conventional Bus
4XCW	BRAKES, FRONT {Meritor Quadraulic} Hydraulic Disc Type, with Four 70mm Diameter Pistons, 12,000-lb Capacity
4XCX	BRAKES, REAR {Meritor Quadraulic} Hydraulic Disc Type, with Four 70mm Diameter Pistons, 21,000-lb Capacity per Axle
5708	STEERING COLUMN Tilting
5CAL	STEERING WHEEL 2-Spoke, 18" Dia., Black
5PSA	STEERING GEAR {Sheppard M100} Power
6DGA	DRIVELINE SYSTEM {Dana Spicer} SPL100, for 4x2/6x2
7DXS	EXHAUST SYSTEM Horizontal Dual Catalytic Converters, Frame Mounted Muffler Right Side, Includes Long Horizontal Tail Pipe, for use with Propane or Gasoline Engines
7WBL	TAIL PIPE (1) Horizontal, Long, Exits Left Side Through Bumper
8000	ELECTRICAL SYSTEM 12-Volt, Standard Equipment <u>Includes</u>

**Vehicle Specifications**  
**2022 INTEGRATED CE S BUS (PB105)**

December 15, 2020

<u>Code</u>	<u>Description</u>
	: HAZARD SWITCH Push On/Push Off, Located on Top of Steering Column Cover
	: HEADLIGHT DIMMER SWITCH Integral with Turn Signal Lever
	: MISCELLANEOUS FEATURES Modular, Loom Protected, Grommets in all Applicable Body Openings, Assembled in Computer Assisted Fixture which Verifies Continuity and Correct Assembly Prior to Installation
	: PARKING LIGHT Integral with Front Turn Signal and Rear Tail Light
	: STARTER SWITCH Electric, Key Operated
	: TURN SIGNAL FLASHER
	: TURN SIGNAL SWITCH Self-Cancelling with Lane Change Feature
	: TURN SIGNALS, FRONT Includes Reflectors; Flush Mounted
	: WINDSHIELD WIPER SWITCH 2-Speed with Wash and Intermittent Feature (5 Pre-Set Delays), Integral with Turn Signal Lever
	: WIRING, CHASSIS Color Coded and Continuously Numbered
8GHV	ALTERNATOR {Delco Remy 28SI} Brush Type, 12 Volt, 200 Amp Capacity, Pad Mount
8MJP	BATTERY SYSTEM {Fleetrite} Maintenance-Free, (2) 12-Volt 1320CCA Total, Top Threaded Stud
8TTK	BATTERY BOX Steel, with Sliding Tray, 25.25" Wide, for Standard Batteries, 1-3 Battery Capacity, Mounted Left Side Behind Front Axle Perpendicular to Frame Rail
8TUT	COLLISION MITIGATION SYSTEM Omit
8VBD	HORN, ELECTRIC (2) Trumpet Style, Mounted Above Right Frame Rail
8WPB	HEADLIGHTS Halogen, Composite Aero Design, with Daytime Running Lights
8WPX	LIGHTS TURN ADDITIONAL Amber, Mounted at Rear of Front Fender
8WWJ	INDICATOR, LOW COOLANT LEVEL with Audible Alarm
8WXB	HEADLIGHT WARNING BUZZER Sounds When Head Light Switch is on and Ignition Switch is in "Off" Position
8WXC	BRAKE WARNING INDICATOR Light and Audible Alarm; Parking Brake/Motion Warning System for Engaged Parking Brake
8XAH	CIRCUIT BREAKERS Manual-Reset (Main Panel) SAE Type III with Trip Indicators, Replaces All Fuses
8XDX	BK WARN IND,PARK BK NOT SET , Visual and Audible Alarm; Active Upon Ignition Off and Parking Brake Not Set, Reminder to Set Parking Brake
8XHE	STARTING MOTOR {Delco Remy PG260N2} 12 Volt, Less Thermal Over-Crank Protection
9HAD	GRILLE Chrome
9WAB	HOOD TILT ASSIST {EASY TILT} Mechanical
9WAY	FRONT END Tilting, Fiberglass, with Three Piece Construction
	<u>Includes</u>
	: AIR INTAKE SYSTEM Integrated Pre-Cleaning System to Enhance Air Filter Life
	: GRILLE Removable; Fiberglass Painted Hood Color
	: SPLASH SHIELD Integral with Front End Assembly
10020	CHASSIS PAINT Full Chassis
10060	PAINT SCHEMATIC, PT-1 Single Color, Design 100
	<u>Includes</u>
	: PAINT SCHEMATIC ID LETTERS "NB"
10788	PAINT TYPE Urethane, One or Two Colors, Other than Imron or International.
10947	KEYS - ALL ALIKE Fleet, Ignition Only
10WBE	KEYS - ALL ALIKE, ID Z-001
10WHJ	SPECIAL ROUTING CONTROL To Bus Vehicle Modification Center
10XAK	PROMOTIONAL PACKAGE 7 Year Unlimited Miles/km Warranty, Limited Time Program for Allison 2500 Series Transmission on School and Commercial Buses (Supplied directly through Allison)
11001	CLUTCH Omit Item (Clutch & Control)
12DLP	ENGINE, GASOLINE {Power Solutions International 8.8 Liter GAS} EPA 2018, 265 HP @ 2600 RPM, 548 lb-ft Torque @ 1800 RPM, 2700 RPM Governed Speed, 265 Peak HP (MAX)
12TSV	FAN DRIVE {Borg-Warner SA75} Viscous Type, Screw On
12UGN	THROTTLE, HAND CONTROL Electronic
	<u>Notes</u>
	: Cruise Control Switches Mounted on Steering Wheel are Non-Illuminated.
12VBR	AIR CLEANER with Service Protection Element
	<u>Includes</u>
	: GAUGE, AIR CLEANER RESTRICTION Air Cleaner Mounted
12VHU	FEDERAL EMISSIONS {Power Solutions International 8.8L GAS} EPA, OBD and GHG Certified for Calendar Year 2021
12VVN	CRUISE CONTROL Electronic

**Vehicle Specifications**  
**2022 INTEGRATED CE S BUS (PB105)**

December 15, 2020

<b><u>Code</u></b>	<b><u>Description</u></b>
	<u>Notes</u> : Cruise Control Switches Mounted on Steering Wheel are Non-Illuminated.
12VWH	GOVERNOR Electronic Road Speed Type; for Electronic Engines and Bus Models; with 55 MPH Default
12WUK	BLOCK HEATER, ENGINE {Phillips} 120V/1000W, with "Y" Cord for 120V/150W Oil Pan Heater
12XBA	RADIATOR Aluminum, Down Flow, 665 SqIn, Includes In-Tank Oil Cooler
13ARW	TRANSMISSION, AUTOMATIC {Allison 2550 PTS} 5th Generation Controls, Wide Ratio, 6-Speed with Double Overdrive, Less PTO Provision, Less Retarder, Includes Park Pawl, with 30,000-lb GVW and GCW Max, School Bus
13WLN	TRANSMISSION OIL Synthetic; 20 thru 28 Pints
13XAW	SHIFT CONTROL PARAMETERS {Allison} 1000 or 2000 Series Transmissions, Performance Programming (Shift Schedule Defined as Limiting) in Primary, and Allison SA Programming in Secondary
14AGM	AXLE, REAR, SINGLE {Dana Spicer 19060S} Single Reduction, 19,800-lb Capacity, 190 Wheel Ends . Gear Ratio: 6.17
	<u>Includes</u> : REAR AXLE DRAIN PLUG (1) Magnetic, For Single Rear Axle
	<u>Notes</u> : The following features should be considered when calculating Rear GAWR: Rear Axles; Rear Suspension; Brake System; Brakes, Rear Air Cam; Brake Shoes, Rear; Special Rating, GAWR; Wheels; Tires. : When Specifying Axle Ratio, Check Performance Guidelines and TCAPE for Startability and Performance
14SBK	SUSPENSION, REAR, SINGLE 19,800-lb Capacity, Two Stage Vari-Rate Springs
	<u>Notes</u> : The following features should be considered when calculating Rear GAWR: Rear Axles; Rear Suspension; Brake System; Brakes, Rear Air Cam; Brake Shoes, Rear; Special Rating, GAWR; Wheels; Tires.
14WAP	SHOCK ABSORBERS, REAR (2)
14WMN	AXLE, REAR, LUBE {EmGard FE-75W-90} Synthetic Oil; 1 thru 29.99 Pints
15SZT	FUEL TANK, GASOLINE Top Draw, Steel, Rectangular, 100 US Gal, (397L) Capacity, Includes Protective Cage, for Low Profile Fuel Filler Assembly and Vent Hosing, Mounted Between Frame Rails and Behind Rear Axle
16010	COWL Flat Back
16HBA	GAUGE CLUSTER English with English Electronic Speedometer
	<u>Includes</u> : GAUGE CLUSTER (5) Engine Oil Pressure (Electronic), Water Temperature (Electronic), Fuel (Electronic), Tachometer (Electronic), Voltmeter : ODOMETER DISPLAY, Miles, Trip Miles, Engine Hours, Trip Hours, Fault Code Readout : WARNING SYSTEM Low Fuel, Low Oil Pressure, High Engine Coolant Temp, and Low Battery Voltage (Visual and Audible)
16HCS	GAUGE, TEMPERATURE, AMBIENT Sensor Wiring with Display Unit Mounted in Cluster
16HKT	IP CLUSTER DISPLAY On Board Diagnostics Display of Fault Codes in Gauge Cluster
27DTU	WHEELS, FRONT {Accuride 29001} DISC; 22.5x7.50 Rims, Powder Coat Steel, 5-Hand Hole, 10-Stud, 285.75mm BC, Hub-Piloted, Flanged Nut, with Steel Hubs
28DTU	WHEELS, REAR {Accuride 29001} DUAL DISC; 22.5x7.50 Rims, Powder Coat Steel, 5-Hand Hole, 10-Stud, 285.75mm BC, Hub-Piloted, Flanged Nut, with Steel Hubs
47AGC	BODY, BUS Conventional; 78" Headroom, 31'2" Body Length, +9 Section Front and Rear, 66 Passenger, 254 WB
47AJC	BODY TAG, METAL Capacity to Include the Total Number of Passengers
47APR	HEADLINER, BODY Conventional; 25'11"-34'11" Body Length, Perforated Full Length with Sound Insulation Full Length
47APW	FASTENERS, HEADLINER Rivets
47ARH	BOWS, ROOF 14 ga., One Piece Construction
	<u>Includes</u> : BOWS, ROOF Positioned Floor Line to Floor Line, Threaded Through Roof Strainers and Drip Rail
47ARP	LIGHT BARS Plastic
47ATB	SKIRT, BODY Conventional, 20", 16ga., 31'2", 31'11", 32'8", 33'5", 34'2", 34'11", Body Length
	<u>Includes</u> : SKIRT, BODY Extra Smooth Steel Supported by Floor Gussets
47AXT	RUB RAILS, BODY (4) Conventional; Steel, 31'2", 31'11", 32'8", 33'5", 34'2", 34'11", Body Length, Includes Snow Rail
	<u>Includes</u>

**Vehicle Specifications**  
**2022 INTEGRATED CE S BUS (PB105)**

December 15, 2020

<b>Code</b>	<b>Description</b>
47AYB	: RUB RAILS Full Length, Primer Coated (Both Sides), Attached to Body without Cuts or Splices BODY, REAR Includes Emergency Door <u>Includes</u> : DOOR, REAR EMERGENCY with Concealed Hinges
47AZE	: HEADER BUMPER Padded, Mounted Over Rear Door; Upholstered to Match Passenger Seat Color SIDE SHEET, BODY, EXTERIOR Conventional, 16ga., Smooth, 31'2", 31'11", 32'8", 33'5", 34'2", 34'11", Body Length
47AZL	FLOOR, BODY with Wheel Wells
47AZZ	RAILS, WRAP-AROUND Just Below Window Line
47BAK	BUMPER, REAR Painted, 12" High, 3/16" Thick
47BAR	SUPPORTS, REAR BUMPER Bolted to Frame
47BBH	LINING, SIDE INTERIOR, LOWER Embossed Steel, Clear Coated
47BBZ	SEALER Extra; Sidewall to Floor, In Wheel Pocket Area, and Rear Wall to Floor
47BDA	FLOOR, COATING , Chemguard Metal Coating, Applied to Main Floor and Intermediate Sills
47BKK	LETTERS, SCHOOL BUS FRONT/REAR Decal; "SCHOOL BUS"; with 8" Black Reflective Letters, 3M Fluorescent Diamond Grade, Yellow On Front and Rear Cap
47BLD	STEP, FRONT ENTRANCE DOOR 27 1/4" Depth; 14ga Steel, Formed Treads, Naviflex Finish
47DAJ	COVER, REAR DOOR INSIDE HANDLE Partial Coverage
47DAK	FASTENERS, REAR DOOR Bolts and Nutserts, Rear Door To Body
47DDE	HANDLE, ASSIST, ENTRANCE DOOR Outside Entrance
47DDH	HOLD BACK, REAR DOOR Stationary, No Cables, with Plastic Cover
47DDU	LATCH, REAR DOOR One Point Slide Bar, Cam Operated, with One Inch Stroke
47DEK	LOCK, REAR DOOR with Ignition Starter Interlock
47DEY	HANDLE, EXTERIOR, REAR Emergency Door; Yellow
47DNB	DOOR, ENTRANCE, FRONT Electric, Outward Opening, with Split Pane Glass <u>Includes</u> : DOOR, ENTRANCE, FRONT Aluminum Frame with Pin Style Hinges, Ball Bearing Assisted, Interchangeable Top and Bottom Glass Lock : LOCK, ENTRANCE DOOR With Key Switch
47DNU	SWITCH, LOCATION Redundant Right Side Door Controls; Steering Wheel and Left of Driver; Includes Master Flasher Switch, Flasher On/Off Control, and Red Override Control <u>Includes</u> : SWITCH, STEERING WHEEL, LIGHT Includes Illuminated Switches
47DWV	KEYS ALIKE, LOCKS Entrance Door, 545 Keys
47DXZ	PAINT, RUB RAIL Flange to Flange, Including Top Flange of Window Line Rub Rail
47EBM	HOLD DOWN, BATTERY For (2) Standard Size Batteries
47KDC	MONITOR, POST TRIP INSPECTION {Leave No Student Behind} Accessory Controlled, with Push Button Alarm Disable at Rear of Bus in Light Bar Prompts Driver to Walk to Back of Bus to Disable Alarm
47KKM	TIE DOWNS, BODY with Grade 8 Bolts, Every Body Section, with Reinforcements
47LAU	INSULATION, ROOF AND SIDES 1.50", All Models
47MAC	UNDERCOAT, FLOOR/STEPWLL/SIDES for Engine Noise Reduction
47MBA	UNDERCOAT, BODY Fire Resistant, Water Based, TT-C-730 Spec <u>Includes</u> : UNDERCOATING Performed Before and After Mounting on Chassis
47MNM	LETTERS, BATTERY COMPARTMENT (01) Decal; "Battery"; 2" Black Letters, Centered on Standard Battery Box
47MNT	ARROW, RR DOOR, INSIDE Decal; Red, .75" Stroke, Indicating Handle Direction
47MNV	ARROW, RR DOOR, OUTSIDE Decal; Black .75" Stroke, Indicating Handle Direction
47MTY	WIRING DIAGRAM Schematic, Electrical <u>Includes</u> : ACCESS PANEL for Wiring Diagram Schematic Located on Body Exterior; Below Driver Window
47MVA	LETTERS, HEADER Decal; "WATCH YOUR STEP", 1" Black, Above Windshield
47MVC	LETTERS, STEPWELL Decal, "WATCH YOUR STEP", 2.5" Black, Behind Door on Step Riser
47NAB	PAINT COLOR, RUB RAILS 0001 Canyon Black
47NGB	LETTERS, DOOR, REAR Decals; "EMERGENCY DOOR", 2" Red Reflective Letters Inside and Outside
47NGV	SEAL, RUB RAILS Top Edge, All Rails
47NJA	PAINT COLOR, BODY EXTERIOR 4421 School Bus Yellow
47NJM	PAINT FLASHER BACKGRD 0001 Canyon Black

**Vehicle Specifications**  
**2022 INTEGRATED CE S BUS (PB105)**

December 15, 2020

<b>Code</b>	<b>Description</b>
47NJS	PAINT COLOR, BUMPER Rear, 0001 Canyon Black
47NKD	PAINT COLOR, ROOF 9219 Winter White, Beginning 5" Above Drip
47NKM	PAINT COLOR, BODY INTERIOR 9384 Spring White
47NMG	OPERATING INSTR, REAR Decal, Inside Rear Emergency Door
47NND	LETTERS, E/E WINDOW, LEFT (01) Decal Set, "EMERGENCY EXIT", Red Inside and Outside
47NPB	LETTERS, E/E WINDOW, RIGHT (01) Decal Set, "EMERGENCY EXIT", Red, Inside and Outside
47NTE	LOGO, ROOF LINE Decal; Wing and Shield, First Body Section, Above Driver Window and Entrance Door Over Driver Window and Entrance Door
47NTY	PAINT HOOD AND FENDER To Match Body Exterior
47NWH	STRIPING, ROOF HATCH, REAR {3M} Decal, Perimeter, 1" Yellow Fluorescent Diamond Grade
47NWT	STRIPING, ROOF HATCH, FRONT {3M} Decal, Perimeter, 1" Yellow Fluorescent Diamond Grade
47NXD	STRIPING, E/E WINDOW, RIGHT {3M} (01) Perimeter, 1" Yellow Fluorescent Diamond Grade
47NXG	STRIPING, E/E WINDOW, LEFT {3M} (01) Perimeter, 1" Yellow Fluorescent Diamond Grade
47NXN	STRIPING, PERIMETER, REAR {3M} Emergency Door, 1" Yellow Fluorescent Diamond Grade
47NYH	BODY RATING TAG Mylar; for State of New Jersey
47PAR	BODY CERTIFICATION TAG Mylar Label, with Actual Tire Load Rating
47PBZ	HANDLE, ASSIST Windshield Side Mounted, Left and Right, Body Color
47PGX	LETTERS, FUEL I.D. Decal; "UNLEADED GASOLINE ONLY", 2" Black, Adjacent to Fuel Filler Door
47SBB	SUB FLOOR, PLYWOOD Conventional; B-B Marine Grade, Less Sealed Edges, 5/8", 5 Ply, for 31'2", 31'11", 32'8", 33'5", 34'2", 34'11", Body Length
48ACN	SEAT BELT, DRIVER, COLOR with Blaze Orange Seat Belt Webbing
48ANT	WINDOW, DRIVER Laminated, Clear
48APL	WINDOW, STOPS 12" Opening, Only with 78" Headroom
48ARP	WINDOW, SASH (16) 27" Sections, 9"x 23" Opening
48AST	WINDOW, SASH +9 SECTIONS (4) 9" x 32 1/4" Opening
48BAG	WINDOW, E/E, LEFT (01) Vertical Hinge
48BJA	COLOR, WINDOW FRAME, PASS Passenger Window, Natural Aluminum Finish
48BKN	WINDOW, E/E, RIGHT (01) Vertical Hinge
48BUB	WINDOW, PASSENGER, TINT Conventional; 28% Light, Tempered Glass, 78" Headroom, with 34'11", 31'2", 31'11", 32'8", 33'5", 34'2" Body Lengths
48GHC	HEATER, DRIVER 90,000 BTU, with Defroster and without Rear Heat Duct <u>Includes</u> : AIR FILTER : HEATER HOSES Premium : HOSE CLAMPS, HEATER HOSE Mubea Constant Tension Clamps
48GHX	SEAT, DRIVER {National 2000SC} Self Contained with Compressor, High Back, Heated, with Mechanical Lumbar
48GYV	HEATER, DEFLECTOR Kit, for Driver Heater
48PAM	WINDSHIELD 3 Flat Pieces, 73% Light, with Band
48PAV	WHEEL POCKET COVER Plastic, ABS
48PAW	AISLE POSITION for 45" Left and 30" Right (15" aisle)
48PBB	FLOOR COVERING, COLOR Black
48PHN	UPHOLSTERY, PASS SEATS, TYPE Prevaill, 42 oz.; for (21-22) Seats
48PKC	HOSE CLAMPS, HEATER HOSE Constant Torque for Heater System
48PKN	FAN, DEFOG FAR RIGHT (01) Black, Mounted Right Above Windshield, Forward Entrance Door, 2-Speed Switch in Panel
48PMJ	HEATER, PASS, LT REAR 84,500 BTU <u>Includes</u> : AIR FILTER
48PMS	HEATER, STEPWELL 50,000 BTU <u>Includes</u> : AIR FILTER
48PNZ	HEATER, WATER PUMP {2 MPU 12} Self Priming, Metal Housing
48PPE	KICK GUARD, REAR, LT for 84,500 BTU Passenger Heater
48PPM	HEATER CUT OFF, VALVE Ball, with Butterfly Handle
48PPP	HEATER CUT OFF, VALVE INSIDE Brass Ball, Inside Driver Area
48PPS	ROOF VENT, FRONT Static
48PTT	ARM REST, DRIVER, RIGHT {National}

**Vehicle Specifications**  
**2022 INTEGRATED CE S BUS (PB105)**

December 15, 2020

<b>Code</b>	<b>Description</b>
48PUP	FLOOR COVERING, TRIM Omit
48PUT	NUTS, BELT MOUNTING Standard Nuts For Seat Belt Mounting
48PVA	UPHOLSTERY, DRIVER SEAT, STYLE Plain, with Cloth Insert
48PVN	UPHOLSTERY, DRIVER SEAT, COLOR Drivers Seat, Gray
48PWE	UPHOLSTERY, PASS SEATS, COLOR Black, for Seats, Barriers and Head Bumpers
48PWN	UPHOLSTERY, DRIVER SEAT, TYPE Vinyl, 42 oz.
48PXP	UPHOLSTERY, BARRIER, TYPE (1-2) Prevaill, 42 oz.
48RAA	BARRIER, CRASH, AFT ENTRY DOOR 30", 1 Leg
48RAM	BARRIER, CRASH, AFT DRIVER 45", 1 Leg
48RDL	FAN, DEFOG LEFT OF DRIVER 6.50" Diameter, Black, Mounted Left of Driver Above Windshield, 2 Speed Switch in Panel
48REP	PANEL, MODESTY, AFT OF DRIVER Mounted Under Barrier
48RET	PANEL, MODESTY, AFT ENTR DOOR Mounted Under Barrier
48RGE	HAND RAIL, ENTRANCE DOOR, FWD Stainless Steel; Curved
48RGR	HAND RAIL, ENTRANCE DOOR, AFT Stainless Steel, 4", Above Step
48RLX	CUSHION, SEAT 15" Depth <u>Includes</u> : WARRANTY Four Years
48RRA	UPHOLSTERY, SEAT, STITCHING Single <u>Includes</u> : WARRANTY Two Years
48UCP	ROOF HATCH, FRONT {Transpec 1975-028-121-03} with Outside Release, with English Decals
48UCR	ROOF HATCH, REAR {Transpec 1975-028-121-03} with Outside Release, with English Decals
48USV	SEAT BACK, PASSENGER High Back
48UWV	FLOOR COVERING, TYPE Koroseal, One Piece, Vinyl, All Body Lengths, Black
48VVR	STEP TREADS {Koroseal} Pebble White Nosing Only, with Non-Metal Backing, used with Formed Treaded Steps
48YDX	SEAT,PASS,3PT,LT,30",2 LEG {BTI Seating System} (01) High Back, with 3 Point Seat Belts
48YGA	SEAT,PASS,3PT,RT,30",2 LEG {BTI Seating System} (11) High Back, with 3 Point Seat Belts
48YLW	SEAT,PASS,3PT,LT,45",2 LEG {BTI Seating System} (10) High Back, with 3 Point Seat Belts
49001	BODY PLAN, APPROVED VARIATION Number 001
49ABB	LIGHTS, BACK UP (2) 7" Diameter, Clear
49ABE	WIRING MOD, BACK UP LIGHTS Connected to Rear Emergency Door Switch to Activate Backup Lights on the Rear Panel Only
49ACU	LIGHTS, DIRECTIONAL, REAR (2) 7" Amber, without Arrow
49ADC	LIGHTS, WARNING (8) Quartz Halogen Beams, 7", 2 Front, 2 Rear, Red and Amber Lights
49ADX	LIGHTS, TAIL, LICENSE PLATE (2) 4" Red with Light Window
49AEU	LIGHTS, STOP (2) and Tail, 7" dia., Red
49AJH	CONNECTION, LIGHTS Cluster, Clearance and Side Marker To Tail Lights
49AMD	SWITCH, DRIVER PANEL, TYPE Rocker
49AMT	CIRCUIT, PROTECTION Breakers, Manual Reset in Lieu of Fuses <u>Includes</u> : ACCESS PANEL for Body and Chassis Fuses/Circuit Breakers Located on Body Exterior; Below Driver Window
49AMY	SWITCH, REAR DOOR BUZZER for Emergency Door
49ANH	SWITCH, MAGNETIC, DISCONNECT Master, Ignition Operated, All Body Circuits
49ANU	SOURCE, POWER 12 VDC, Mounted In Dash
49ATV	LIGHT, INDIC, WARNING LIGHTS Red and Amber <u>Includes</u> : LIGHTS, WARNING Indicator Located in Instrument Cluster
49AWV	SPEAKERS AND WIRING (8) Flush Mounted In Light Bar
49BCN	FLASHER SYSTEM (8) Warning Lights, 8-Lamp System, Electronic Relay Flasher, Non-Sequential Operation, Red Lights Activate with Door Open
49BCR	LIGHT, EXTERIOR, CHECK Automatically Activates Lights for Pre Trip Inspection
49BDL	MONITOR, LIGHT SYSTEM {Sound Off/OptiLuxx} with 16 LED or Incandescent Indicator Lights
49BDT	ALARM, BACKING {Ecco #SA-917-87} 112 db, Self Adjusting 5db Above Ambient Noise Level
49BLL	WIRING, VIDEO SYSTEM Power and Ground Connection Only; Connection in Flasher Plate Area with 20 Amp Fuse Protection



**Vehicle Specifications**  
**2022 INTEGRATED CE S BUS (PB105)**

**December 15, 2020**

<b>Code</b>	<b>Description</b>
49BLM	WIRING, TWO WAY RADIO Power and Ground Connection Only; Connection in Flasher Plate Area with 20 Amp Fuse Protection
49BLW	FUEL FILLER DOOR Key Locking, Lever Latch, Spring Loaded to Hold in Open Position
49BTL	ANTENNA REI # 210073, Flexible Rubber Antenna with Swivel Base and 160" Cable
49BVD	SWITCH, BATTERY Shut-Off, 300A Weather Resistant, In Battery Compartment
49BVG	MIRROR, CROSS VIEW, EXTERIOR (2) {Mirror Lite High Definition Busboy} Black, Heated
49BXN	SWITCH, RED, OVERRIDE WARNING Wired Hot, with ESC, Mounted Left of Driver
49BYW	LIGHTS, DOME {Sound Off/OptiLuxx} (06) LED, Rectangular Recessed Type, Mounted in Light Bar
49BZU	RADIO, ENTERTAINMENT {Custom Radio} AM/FM Stereo/USB Input, Includes Antenna and Cable, with Public Address System
49CKT	FUEL FILLER PIPE Low Profile Neck Cap and Vent Hosing, for Use with Right Side Fill for Between the Rail Fuel Tanks, for Above the Floor Fuel Fill, for 25 GPM Fill Rate Only
49DBR	HOOD, WARNING LAMP (4) Black, 8-Lamp System, One Hood Above Two Lights
49EKL	MIRROR, INSIDE Omit
49EKR	STOP ARM, FRONT Electric, Metal Blade, 18" Octagon, Double Sided, 1/2" White Border, Engineering Grade, Flashing Red Incandescent Lights
49ENK	VISOR, INTERIOR, LEFT FRONT 6" x 30", Transparent, For Left Windshield
49ERT	LIGHT, RED, EMERG EXIT, REAR 3" Inside, Over Rear Door, LED, Connected to Clearance Lights
49EXD	MIRROR, REAR VIEW, EXTERIOR {Rosco Open-View} Black, Motorized Head, Heated, Non-Detent
49GBV	WINDSHIELD WIPERS (2) Cowl Mounted <u>Includes</u> : WINDSHIELD WIPERS CONTROL Single Motor, Overlapping Wipe Pattern
49GDG	PADDING COMPART ABOVE DRIVER Window; Safety Equipment Compartment, with Cutout for Dome Light
49GDS	COMPARTMENT ABOVE DRIVER Left of the Driver <u>Includes</u> : COMPARTMENT ABOVE DRIVER Compartment Size: 39" x 10" x 10" : HINGES Piano Type
49GEH	SAFETY TRIANGLES Warning Reflectors, Mounted on Drivers Barrier 9.5" Above Floor
49GGE	FIRE EXTINGUISHER, DRIVER AREA 5 lb 2A-40BC Minimum with Flexible Hose and Metal Nozzle
49GHN	REFLECTORS, REAR (2) 3", Red, Adhesive Back
49GHR	REFLECTORS, SIDE, REAR (2) 3", Red, Adhesive Back
49GHV	REFLECTORS, SIDE, FRONT (2) 3", Amber; Adhesive Back, 1 Aft Drivers Window Left, 1 Aft Entrance Door Right
49GHX	REFLECTORS, SIDE, INTERMEDIATE (2) 3" Amber, 1 Each Side, Below The Third Rub Rail From the Top, Adhesive Back
49GUH	CERTIFICATE HOLDER (1) 9.375" x 6"; with Transparent Cover
49GUK	FENDERS, RUBBER, REAR (2)
49GUW	MOISTURE BARRIER, FLOOR Between Plywood and Steel; for AK Body
49GUX	MUD FLAPS, FRONT WHEELS (2) Rubber
49GVH	MUD FLAPS, REAR WHEELS (2) Brackets Only
49GWW	WINDSHIELD WASHER Kit; 6 Quart Capacity, Bottle <u>Includes</u> : WINDSHIELD WASHER ELECTRICAL CONNECTIONS Sealed and Locking Type
49JBS	LIGHTS, CLUSTER {Sound Off/OptiLuxx} Oval, 4 Internal LEDs per Light; Amber Front and Red Rear
49JBW	LIGHT, STEP {Sound Off/OptiLuxx} 4" Round LED, White, Wired to Clearance Lights, Operated by Entrance Door
49JBY	LIGHTS, MARKER, FRONT & REAR (4) {Sound Off/OptiLuxx} LED, Armored, Slim-Line, (2) Amber Front and (2) Red Rear
49JCW	INSPECTION PLATE Fuel Sending Unit 11.4" x 8" Aluminum Diamond Tread Mounted Flush with Floor Mat
49MZV	LATCH, COMPARTMENT Locking, for Overhead Storage Compartment
49NAL	LIGHTS, DOME, DRIVER (3) {Sound Off/OptiLuxx} LED, Rectangular, Mounted Left & Right Sides in Ceiling and in Light Bar Left of Driver, with Separate Switch
49PSY	LIGHTS, DIRECTIONAL, SIDE {Sound Off/OptiLuxx} (2) Slim-Line LED Armored, Amber, (1) Each Side First Section Aft Entrance Door
49UBK	STATE OF OPERATION New Jersey
49ZNE	LIGHTS, MARKER, SIDE, INTERMED {Sound Off/OptiLuxx} LED, Amber, Slim-Line, Armored, Intermediate, Centered, Required for Units 30 Foot or Longer

**Vehicle Specifications**  
**2022 INTEGRATED CE S BUS (PB105)**

**December 15, 2020**

<b><u>Code</u></b>	<b><u>Description</u></b>
50VWW	BODY PLAN, NON-SPECIAL NEEDS Conventional; 31' 02" Body Length, +9 Section Front & Rear, 54 Passenger, 254" WB, DJ0133A000
7372115808	(4) TIRE, REAR 10R22.5 Load Range G DH01 (HANKOOK), 512 rev/mile, 75 MPH, Drive
7372115809	(2) TIRE, FRONT 10R22.5 Load Range G AH37 (HANKOOK), 517 rev/mile, 75 MPH, All-Position
OBD001	CONTROL, ENTRANCE DOOR ELECTRIC DOOR
 <b>Services Section:</b>	
40126	WARRANTY Standard for CE, RE, BE School Bus Models, Effective with Vehicles Built March 1, 2017 or Later, CTS-3304H
49GVN	WARRANTY 5-Year, Limited

**Electronic Parameters Summary**  
**2022 INTEGRATED CE S BUS (PB105)**

December 15, 2020

(0012DLP)  
ATTACHMENTS: 0012VVN

<b><u>Parameter</u></b>	<b><u>Value</u></b>	<b><u>UOM</u></b>
Max Accelerator Vehicle Speed Limit	66	MPH

These Electronic Parameters have been successfully finalized

**Turning Radius Summary**  
**2022 INTEGRATED CE S BUS (PB105)**

December 15, 2020

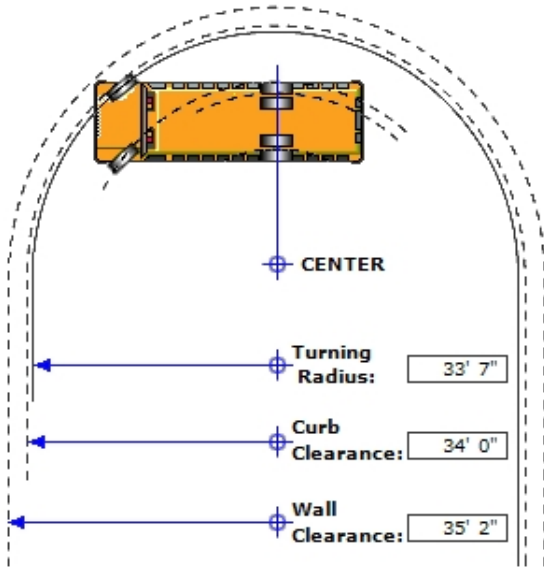

Series: INGB  
 Model: PB105  
 Description: INTEGRATED CE S BUS  
 Model Year: 2022

**Calculation Factors**

Wheelbase: 254  
 Front Axle: 0002ASH  
 Description: AXLE, FRONT NON-DRIVING, {Meritor MFS-10-122A} I-Beam Type, 10,000-lb Capacity  
 Front Wheel: 0027DTU  
 Description: WHEELS, FRONT, {Accuride 29001} DISC; 22.5x7.50 Rims, Powder Coat Steel, 5-Hand Hole, 10-Stud, 285.75mm BC, Hub-Piloted, Flanged Nut, with Steel Hubs  
 Front Tire: 07372115809  
 Description: TIRES, 10R22.5 Load Range G AH37 (HANKOOK), 517 rev/mile, 75 MPH, All-Position  
 Steering Gear: 0005PSA  
 Description: STEERING GEAR, {Sheppard M100} Power

**Turning Radius Statistics**

General Information

Inside Turn Angle: 50 Degrees  
 Radial Overhang: 19

Axle Information

KingPin Inclination: 6.25 Degrees  
 KingPin Center: 69

**Turning Radius - Curb View**

C - Curb Contact Length: 15.37  
 CI - Curb Clearance Increment: 5.29  
 CR - Curb Clearance Radius: 34'0"  
 CH - Curb Height: 6"  
 TR - Turning Radius: 33'7"  
 TW - Tire Width: 10.00

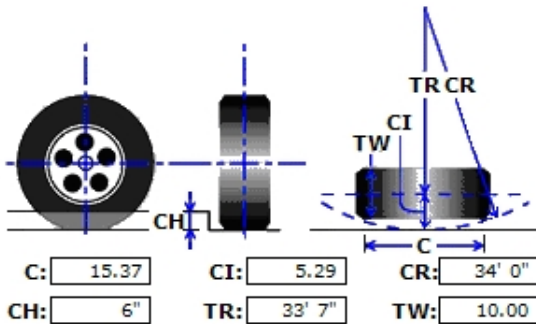

\* All Measurements are in inches, unless otherwise specified.

This information is based on engineering information available at this time. Actual figures may vary. Navistar, Inc. cannot accept liability for consequences due to this variance.