

BUS Ultrasonic Sensors

Precise – reliable



TouchControl

650

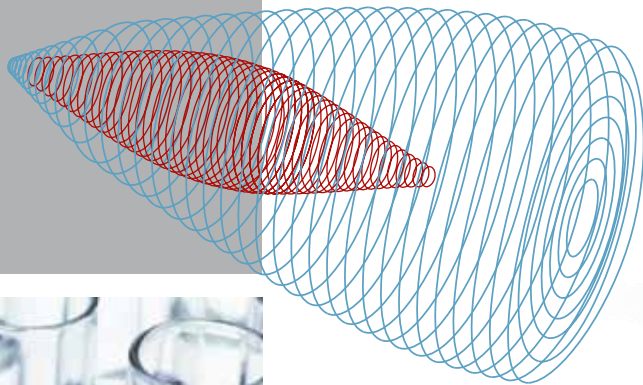
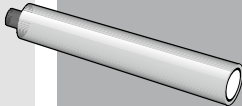

Balluff North America



Florence, Kentucky USA

Balluff's Florence, Kentucky United States headquarters is located just south of Cincinnati, Ohio. Our customers are in industries such as automotive, machine tool, robotics, injection molding, packaging, material handling, and more.

In addition to sales, marketing, and logistic functions, this facility manufactures Micropulse® magnetostrictive linear position sensors and warehouses over 60,000 products.

The Balluff Global Network

Balluff spans the globe with representation in 49 countries.



- | | | | | | |
|-----------|----------------|-----------|-------------|--------------|-------------|
| Argentina | China | Greece | Japan | Poland | Spain |
| Australia | Columbia | Hong Kong | Korea | Portugal | Sweden |
| Austria | Croatia | Hungary | Malaysia | Romania | Switzerland |
| Belarus | Czech Republic | India | Mexico | Russia | Thailand |
| Belgium | Denmark | Indonesia | Netherlands | Singapore | Taiwan |
| Brazil | Finland | Iran | Norway | Slovakia | Turkey |
| Bulgaria | France | Israel | Pakistan | Slovenia | USA |
| Canada | Great Britain | Italy | Phillipines | South Africa | Venezuela |

Ultrasonic Sensors

Precise – reliable

Media	4
Industries, application areas	5
Application areas, definitions	6
Modes	7
M30 tubular-style housing	8
M18 tubular-style housing	10
R06 block-style housing	12
M12 tubular-style housing	14
Q80 block-style housing	15

Regardless of color and material

BUS ultrasonic sensors are perfect for distance measurement or position detection of granules, fluids and powders. They measure fill levels, heights and sag without making contact as well as count and monitor the presence of objects.

They are extremely versatile, operate independently of color and surface finish, and are not affected by transparent objects that generate strong reflections.

Ultrasonic sensors are designed for critical situations. Dust, dirt and steam do not pose a problem.

Broad detection range – high precision

Balluff ultrasonic sensors detection ranges extend from 20 mm to 8 m. Their high resolution and small blind zones ensure extreme precision. Integral synchronization means that the sensors do not interfere with one another.

Switching and analog variants

BUS ultrasonic sensors differ from one another in their output signal. Each series is available as a switching or analog version. All analog versions are available with voltage or current output (0...10 V or 4...20 mA). The BUS M30 includes variants with two switching outputs (one switching and one analog output, or two switching outputs and one analog output) so that one sensor can adopt the function of a second sensor.

IO-Link

BUS 18M sensors with push/pull output are equipped with an IO-Link interface that enables a change from SIO mode to IO-Link mode.



Balluff ultrasonic sensors for difficult environments

Because the distance to the object is determined via a sound transit time, ultrasonic sensors have excellent background suppression. With their transit time measurement, ultrasonic sensors can

record the measured value with highly-precise resolution. Some sensors to even 0.025 mm. The sensors are able to measure in dusty air or through paint spray mist. Nearly all materials that reflect the sound are detected.

Even thin foils, crystal clear materials and different colors are no problem for ultrasonic sensors. Thin deposits on the sensor membrane do not affect sensor function.



Colors

Red, green, yellow or blue — all make no difference to Balluff ultrasonic sensors: they reliably detect all colors.



Transparent layers

Glass plates, Plexiglas and razor thin foils — BUS ultrasonic sensors reliably detect transparent layers.



Surfaces of bulk materials

Fine sand, shavings or coarse-grained materials — in the areas of fill-level measurement, our ultrasonic sensors are unbeatable.



Contrasts

Black objects against a black background or white on white — BUS sensors perform flawlessly regardless of contrast.



Liquids

Clear water, cloudy liquids, oils or black coffee — ultrasonic sensors can be used with nearly any liquid.



Material surfaces

Whether velvet, wool or leather — nearly all clothing materials can be simply detected with our BUS ultrasonic sensors.

BUS ultrasonic sensors are ideal for the following industries

- Handling and automation
- Specialty machine construction
- Automotive industry
- Bottling and packaging
- Pharmaceutical industry
- Plastic and rubber industry
- Timber and furniture industry
- Paper and printing industry
- Conveying
- Commercial vehicles
- Scales
- Agricultural machinery
- Food processing machinery
- Office and information technology
- Construction and building material machinery
- Textile machinery



Handling and automation



Bottling and packaging



Automotive industry

Ultrasonic sensors can be used in many application areas

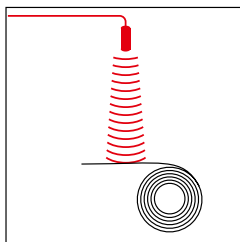

Foil tear monitoring

Ultrasonic sensors with switching output can be used for foil tear monitoring. If large waves are formed in the foil, the sensor should be operated as a diffuse reflective sensor. This operating mode functions reliably even if the sound is reflected by waves in the foil.

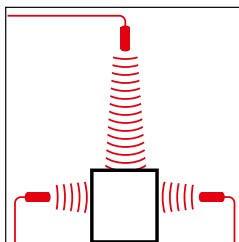

Height and width measurement

Through the use of multiple BUS M30 or BUS 18M ultrasonic sensors, three-dimensional measurements can be made for everything from small boxes to large cartons.

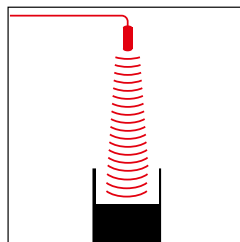

Presence verification

BUS detect filled or empty pallets and measure the content of transport containers. If a box or a container is to be inspected with multiple sensors, they can be synchronized with each other.

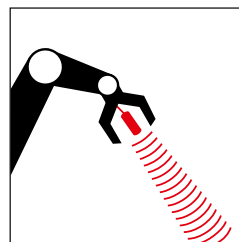

Robot positioning

Due to their small dimensions, BUS are ideally suited for exactly positioning robot arms: BUS 18M ultrasonic sensors in threaded sleeve and BUS R06K in block-style housing.

More applications on the next page

Ultrasonic Sensors

Application areas, sensor selection

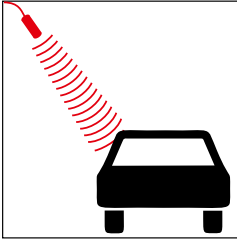

Positioning

When scanning glass plates or other smooth and flat surfaces, make certain that the ultrasound strikes the surface at a right angle.

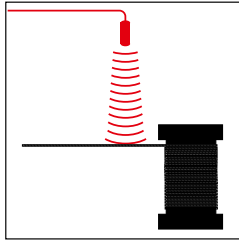

Wire-breakage monitoring

When winding and unwinding a wire rope, ultrasonic sensors with analog output detect its position on the layer.

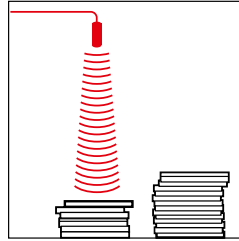

Stack-height detection

Whether wooden boards, glass plates, paper or color plastic plates, BUS ultrasonic sensors measure stack heights with high precision.

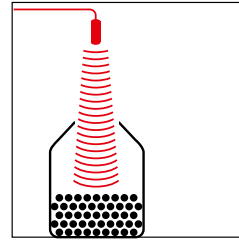

Fill-level monitoring

In silos, bunkers, containers – for all bulk materials (e.g., sand, gravel, coal, grain), our ultrasonic sensors are ideal.

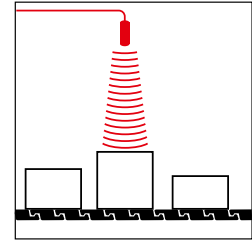

Object detection

BUS ultrasonic sensors sort containers and parts with different heights. BUS count objects. And with absolute reliability.

Sensor selection

Important selection criteria for an ultrasonic sensor are its scanning range and the associated, three-dimensional detection range.



Definitions

Blind zone

The blind zone defines the smallest reliable scanning range of the sensor. There must be no objects or interfering reflections within the blind zone, as measurement errors may otherwise occur.

Operating scanning range

The operating scanning range is the typical working range of a sensor. For objects with good reflective properties, it can also be used up to its limiting scanning range.

Detection range

The detection range is measured using various standard targets.

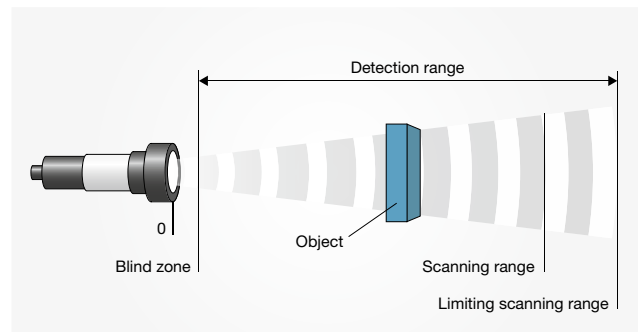

Detection ranges

The red areas are measured with a thin round rod (\varnothing 10 mm or 27 mm, depending on sensor type) and show the typical working range of a sensor.

To obtain the blue areas, a plate is moved into the sound fields from the side. In doing so, the optimum angle of the plate to the sensor is set. This is thus the maximum detection range of the sensor.

It is not possible to evaluate ultrasound reflections outside of the blue sound cones.

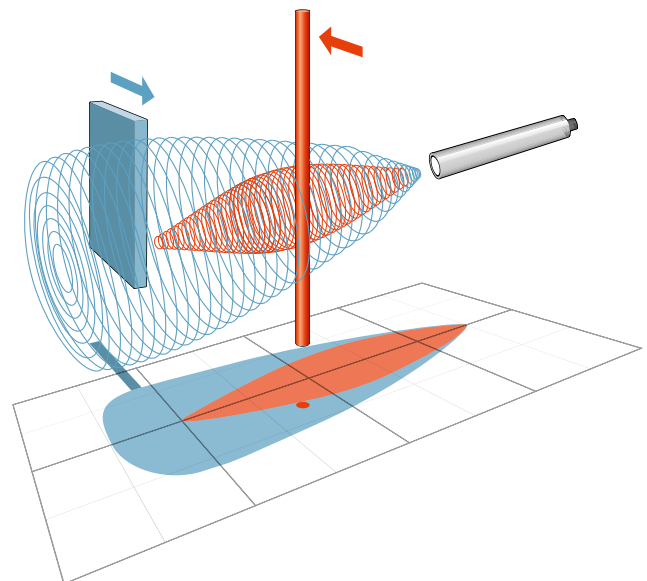

Ultrasonic Sensors

Modes

The **ultrasonic sensor as a diffuse reflective sensor** is the classic operating mode. Compared to other sensor principles, it has superior background suppression. During operation, the switching output is set as soon as the object is located within the set switching distance. The switch point has a hysteresis. The operating mode is suitable for, e.g., counting objects on a conveyor belt or for performing presence verification.

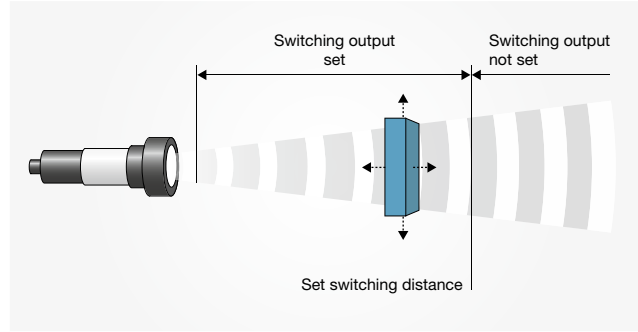

The **ultrasonic sensor in window mode** is an extended function of the ultrasonic diffuse reflective sensor. In this case, the switching output can only be set if the object is located within a window that is defined by two window limits. This can be used to monitor, e.g., the correct bottle size in a bottle crate. Bottles that are too tall or too short are sorted out. Window mode and the diffuse reflection ultrasonic sensor can be set on all ultrasonic sensors that are equipped with teach-in.

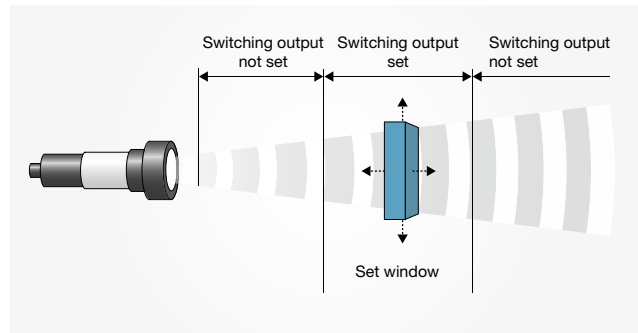

The function of the **diffuse reflection ultrasonic sensor** is similar to that of a photoelectric sensor. Any reflector, such as a metal sheet, is sufficient. In window mode, the ultrasonic sensor is set so that the permanently mounted reflector lies within the window. The ultrasonic sensor returns a signal as soon as an object fully covers the reflector. It plays no role here whether the object completely absorbs or reflects away the sound. This operating mode is therefore used for materials that can be only poorly reflected, such as foam, or for scanning objects with irregular surfaces.

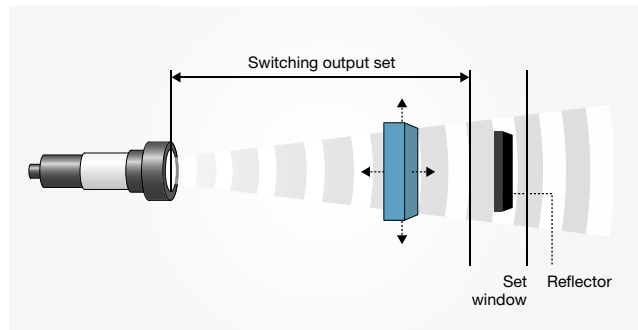

Ultrasonic sensors with analog output output the measured distance value as a voltage that is proportional to distance (0...10 V) or as current that is proportional distance (4...20 mA). For the ultrasonic sensors with analog output, the sensor-near and sensor-distant window limits of the analog characteristic as well as a rising or falling characteristic can be set. Depending on the sensor model and window width, the resolution is between 0.025 mm and 0.36 mm.

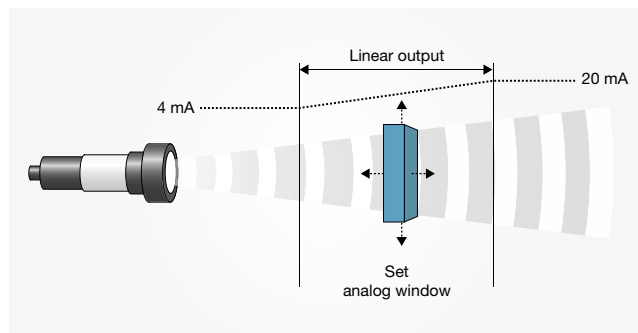

Ultrasonic sensors with IO-Link enable gapless communication through all levels of the system architecture: from the sensor to the top fieldbus level. Transmission of the measured distance value to the controller is bit serial.

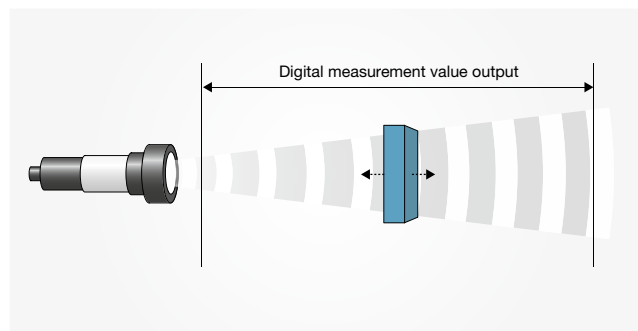

Ultrasonic Sensors

M30 tubular-style housing



Features and benefits

- **Display with direct, measured value output**
for immediately visible results
- **Numeric setting of the sensor via the display**
for completely presetting the sensor
- **Automatic synchronization and multiplex operation**
for simultaneous operation of up to ten sensors
- **5 scanning ranges with a measuring range from 30 mm to 8 m**
- **1 or 2 switching outputs in PNP- or NPN-design**
- **Analog output 4...20 mA and 0...10 V**
Automatic changeover between current and voltage output
- **Analog output plus switching output**
for measurement that is proportional to distance with an additional limit value
- **Teach-in via 2 buttons**
for simple, menu-driven commissioning

Scanning range

Blind zone	
Limiting scanning range	

BUS M30M switching output

Resolution		
PNP, NO/NC contact	Ordering code	
	Part number	
NPN, NO/NC contact	Ordering code	
	Part number	
2x PNP, NO/NC contact	Ordering code	
	Part number	
2x NPN, NO/NC contact	Ordering code	
	Part number	

BUS M30M analog output

Resolution (depends on analog window used)		
0...10 V / 4...20 mA	Ordering code	
	Part number	

BUS M30M switching and analog output

Resolution (depends on analog window used)		
0...10 V / 4...20 mA	Ordering code	
PNP, NO/NC contact	Part number	
0...10 V / 4...20 mA	Ordering code	
2x NPN, NO/NC contact	Part number	

Sensors are also available in stainless steel variants.



TouchControl

With TouchControl, all settings are made on the sensors. The three-digit LED indicator continuously displays the current distance value and automatically switches between mm and cm display. Two buttons are used to call up the configuration and navigate through the self-explanatory menu structure.



Inspecting transport boxes for "in order parts"

Target objects show up on conveyor belts. Multiple ultrasonic sensors simultaneously monitor transport containers for in order parts. Reflective, transparent or different-colored surfaces are reliably detected. In multiplex operation, mutual interference of the sensors is prevented.

Ultrasonic Sensors

M30 tubular-style housing

General data

Supply voltage	9...30 V DC, polarity reversal protected	
Output current	200 mA	
Accuracy	± 1% (temperature drift internally compensated)	
Degree of protection as per EN 60529	IP 67	
Operating temperature	-25...+70°C	
Material	Housing	Nickel-plated brass, plastic parts: PBT, TPU
	Sensing surface	Polyurethane foam, epoxy resin containing glass
Connection	M12 connector, 5-pin	

30...250 mm	65...350 mm	200...1300 mm	350...3400 mm	600...6000 mm
30 mm	65 mm	200 mm	350 mm	600 mm
350 mm	600 mm	2000 mm	5000 mm	8000 mm

0.025 mm	0.025 mm	0.18 mm	0.18 mm	0.18 mm
BUS0022	BUS005F	BUS0039	BUS003P	BUS0045
BUS M30M1-PPX-03/025-S92K	BUS M30M1-PPX-07/035-S92K	BUS M30M1-PPX-20/130-S92K	BUS M30M1-PPX-35/340-S92K	BUS M30M1-PPX-60/600-S92K
BUS002J	BUS005P	BUS0036	BUS003J	BUS0054
BUS M30M1-NPX-03/025-S92K	BUS M30M1-NPX-07/035-S92K	BUS M30M1-NPX-20/130-S92K	BUS M30M1-NPX-35/340-S92K	BUS M30M1-NPX-60/600-S92K
BUS002R	BUS005H	BUS003C	BUS003W	BUS003Z
BUS M30M1-PWX-03/025-S92K	BUS M30M1-PWX-07/035-S92K	BUS M30M1-PWX-20/130-S92K	BUS M30M1-PWX-35/340-S92K	BUS M30M1-PWX-60/600-S92K
BUS002H	BUS005R	BUS0035	BUS0046	BUS0055
BUS M30M1-NWX-03/025-S92K	BUS M30M1-NWX-07/035-S92K	BUS M30M1-NWX-20/130-S92K	BUS M30M1-NWX-35/340-S92K	BUS M30M1-NWX-60/600-S92K

0.025...0.10 mm	0.025...0.17 mm	0.18...0.57 mm	0.18...1.5 mm	0.18...2.4 mm
BUS002N	BUS005K	BUS003F	BUS003T	BUS0041
BUS M30M1-XC-03/025-S92K	BUS M30M1-XC-07/035-S92K	BUS M30M1-XC-20/130-S92K	BUS M30M1-XC-35/340-S92K	BUS M30M1-XC-60/600-S92K

0.025...0.10 mm	0.025...0.17 mm	0.18...0.57 mm	0.18...1.5 mm	0.18...2.4 mm
BUS002L	BUS005M	BUS0038	BUS003L	BUS0043
BUS M30M1-PPC-03/025-S92K	BUS M30M1-PPC-07/035-S92K	BUS M30M1-PPC-20/130-S92K	BUS M30M1-PPC-35/340-S92K	BUS M30M1-PPC-60/600-S92K
		BUS003N	BUS0044	
		BUS M30M1-PWC-20/130-S92K	BUS M30M1-PWC-35/340-S92K	

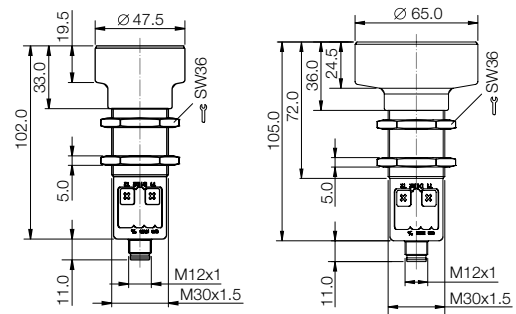
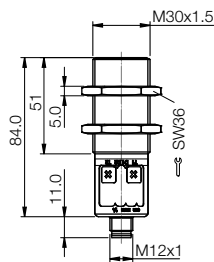

Suitable connector

Size/style	Length/cable material	Ordering code
M12, 5-pin/straight	5 m/PUR	BCC098C
M12, 5-pin/angled	5 m/PUR	BCC08FC

For optional shielded connector

M12, 5-pin/straight/shielded	5 m/PUR	BCC08KP
------------------------------	---------	----------------

Recommended accessories

Description	Ordering code
Mounting cuff	BAM00HN
Mounting clamp	BAM00TN
Mounting bracket	BAM00HH
Sound deflection bracket	BAM01ER

For additional electrical accessories refer to our **Industrial Networking and Connectivity** catalog.

For additional mechanical accessories refer to our website.

Ultrasonic Sensors M18 tubular-style housing



Features and benefits

- **90° angled M18 housing**
for individual installation situations
- **IO-Link interface**
for supporting the new industrial standard
- **Automatic synchronization and multiplex operation**
for simultaneous operation of up to ten sensors
- **4 scanning ranges with a measuring range from 20 mm to 1.3 m**
- **1 push/pull switching output PNP- or NPN-switching**
- **Analog output 4...20 mA or 0...10 V**
for analog distance measurements
- **Teach-in via control line (pin 5)**

Scanning range

Blind zone	
Limiting scanning range	

BUS M18M switching output, straight

Resolution	
Push/Pull, NO/NC contact, IO-Link	Ordering code Part number

BUS W18M switching output, angled

Resolution	
Push/Pull, NO/NC contact, IO-Link	Ordering code Part number

BUS M18M analog output, straight

Resolution (depends on analog window used)	
0...10 V	Ordering code
Rising/falling	Part number
4...20 mA	Ordering code
Rising/falling	Part number

BUS W18M analog output, angled

Resolution (depends on analog window used)	
0...10 V	Ordering code
Rising/falling	Part number
4...20 mA	Ordering code
Rising/falling	Part number

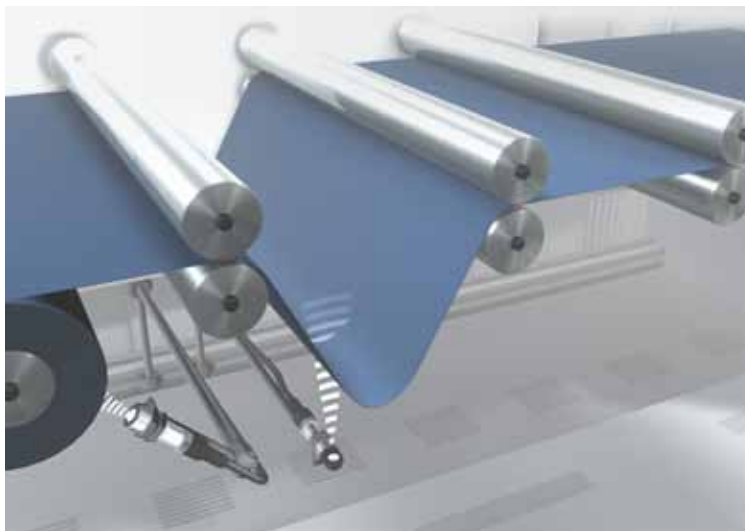

IO-Link – the new standard

With the IO-Link interface, the prerequisites are filled for gapless communication through all levels of the system architecture all the way to the sensor. Commissioning and maintenance of a machine are simplified and productivity is increased.

Control foil sag and monitor roll diameter

Using an ultrasonic sensor with analog output, the material on a roll or a coil is detected and the roll drive or a brake readjusted. Another sensor with analog output readjusts the material infeed at the dancer roller as a function of the cable loop.

Ultrasonic Sensors

M18 tubular-style housing

General data

Supply voltage	10...30 V DC, polarity reversal protected	
Output current	200 mA	
Accuracy	± 1 % (temperature drift internally compensated)	
Degree of protection as per EN 60529	IP 67	
Operating temperature	-25...+70°C	
Material	Housing	Nickel-plated brass tube, plastic parts: PBT
	Sensing surface	Polyurethane foam, epoxy resin containing glass
Connection	M12 connector, 5-pin	

20...150 mm	30...250 mm	65...350 mm	120...1000 mm
20 mm	30 mm	65 mm	120 mm
250 mm	350 mm	600 mm	1300 mm

0.069 mm	0.069 mm	0.069 mm	0.069 mm
BUS0020	BUS0029	BUS004Z	BUS004P
BUS M18M1-GPXI-02/015-S92G	BUS M18M1-GPXI-03/025-S92G	BUS M18M1-GPXI-07/035-S92G	BUS M18M1-GPXI-12/100-S92G

0.069 mm	0.069 mm	0.069 mm	0.069 mm
BUS0023	BUS002A	BUS004Y	BUS004N
BUS W18M1-GPXI-02/015-S92G	BUS W18M1-GPXI-03/025-S92G	BUS W18M1-GPXI-07/035-S92G	BUS W18M1-GPXI-12/100-S92G

0.069...0.10 mm	0.069...0.10 mm	0.069...0.10 mm	0.069...0.10 mm
BUS0026	BUS0024	BUS004T	BUS0052
BUS M18M1-XA-02/015-S92G	BUS M18M1-XA-03/025-S92G	BUS M18M1-XA-07/035-S92G	BUS M18M1-XA-12/100-S92G
BUS0025	BUS002C	BUS004W	BUS004M
BUS M18M1-XB-02/015-S92G	BUS M18M1-XB-03/025-S92G	BUS M18M1-XB-07/035-S92G	BUS M18M1-XB-12/100-S92G

0.069...0.10 mm	0.069...0.10 mm	0.069...0.10 mm	0.069...0.10 mm
BUS0028	BUS0050	BUS004R	BUS0051
BUS W18M1-XA-02/015-S92G	BUS W18M1-XA-03/025-S92G	BUS W18M1-XA-07/035-S92G	BUS W18M1-XA-12/100-S92G
BUS0027	BUS002E	BUS004U	BUS0053
BUS W18M1-XB-02/015-S92G	BUS W18M1-XB-03/025-S92G	BUS W18M1-XB-07/035-S92G	BUS W18M1-XB-12/100-S92G

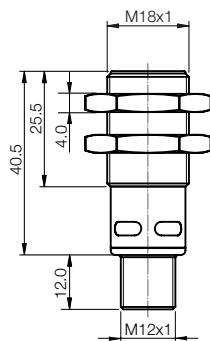

BUS M18...
straight

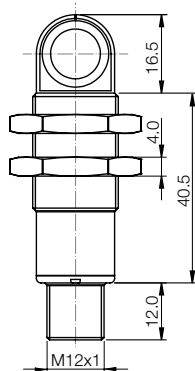

BUS W18...
angled

Suitable connector

Size/style	Length/cable material	Ordering code
M12, 5-pin/straight	5 m/PUR	BCC098C
M12, 5-pin/angled	5 m/PUR	BCC08FC

For optional shielded connector

M12, 5-pin/angled/shielded	5 m/PUR	BCC08KP
----------------------------	---------	----------------

Recommended accessories

Description	Ordering code
Mounting cuff	BAM00F2
Mounting clamp	BAM00T3
Mounting bracket	BAM00EY
Focusing attachment	BAM01HJ
Sound deflection bracket	BAM01EP

For additional electrical accessories refer to our **Industrial Networking and Connectivity** catalog.

For additional mechanical accessories refer to our website.

Ultrasonic Sensors

R06 block-style housing



Features and benefits

- **Small ultrasonic sensor in block-style housing**
ideal for compact applications
- **Same construction as many optical sensors**
a true alternative in critical applications
- **Option for focusing attachment**
for challenging measurement tasks
- **5 scanning ranges with a measuring range from 20 mm to 1 m**
- **1 switching output in PNP or NPN design**
- **Analog output 4...20 mA or 0...10 V**
- **Teach-in via a button**

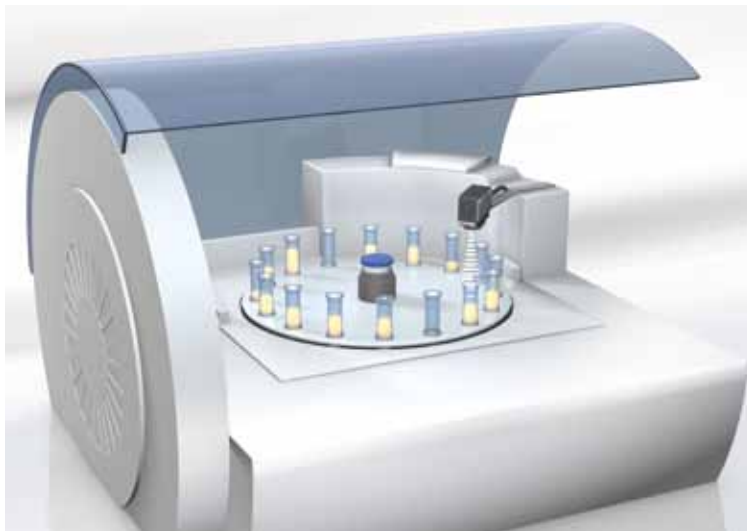

Scanning range

Blind zone	
Limiting scanning range	

BUS R06K switching output

Resolution		
PNP, NO/NC contact	Ordering code	
	Part number	
NPN, NO/NC contact	Ordering code	
	Part number	
PNP, NO/NC contact, 125 Hz	Ordering code	
	Part number	
NPN, NO/NC contact, 125 Hz	Ordering code	
	Part number	

BUS R06K analog output

Resolution (depends on window used)		
0...10 V	Ordering code	
	Part number	
4...20 mA	Ordering code	
	Part number	

Focusing attachment

For fill-level measurement through small openings with diameters to 5 mm, the sensor with focusing attachment is positioned directly over the measurement location. The tightly bundled sound field is focused exactly on the location that is to be measured. The blind zone of the sensor lies within the focusing attachment, making measurement possible starting directly from the sound outlet.



Comment: Can be used with BUS R06K1..-02/007-.. and BUS R06K1..-02/015-.. for measurements in boreholes and filling levels as well as for scanning circuit boards or highly transparent foils.

Fill-level measurement in narrow containers

On a rotary indexing table, narrow containers are filled with liquid or solid media. The ultrasonic sensor then verifies the exact filling level.

Ultrasonic Sensors

R06 block-style housing

General data

Size	20x32x12 mm	
Supply voltage	20...30 V DC, polarity reversal protected	
Output current	200 mA	
Degree of protection as per EN 60529	IP 67	
Operating temperature	-25...+70°C	
Material	Housing	ABS
	Sensing surface	Polyurethane foam
Connection	M8 connector, 4-pin	

20...70 mm	20...150 mm	55...240 mm	30...250 mm	120...700 mm
20 mm	20 mm	55 mm	30 mm	120 mm
100 mm	250 mm	350 mm	350 mm	1000 mm

0.056 mm	0.056 mm	0.037 mm	0.069 mm	0.037 mm
BUS0021	BUS004C	BUS004L	BUS0057	BUS0059
BUS R06K1-PPX-02/007-S75G	BUS R06K1-PPX-02/015-S75G	BUS R06K1-PPX-05/024-S75G	BUS R06K1-PPX-03/025-S75G	BUS R06K1-PPX-12/070-S75G
BUS004E	BUS004A	BUS0048	BUS0058	BUS005A
BUS R06K1-NPX-02/007-S75G	BUS R06K1-NPX-02/015-S75G	BUS R06K1-NPX-05/024-S75G	BUS R06K1-NPX-03/025-S75G	BUS R06K1-NPX-12/070-S75G
	BUS0049			
	BUS R06K1-PPX-02/015-S75G-F01			
	BUS004H			
	BUS R06K1-NPX-02/015-S75G-F01			

	0.056 mm	0.037...0.072 mm		0.037...0.215 mm
	BUS004K	BUS0056		BUS005E
	BUS R06K1-XA-02/015-S75G	BUS R06K1-XA-05/024-S75G		BUS R06K1-XA-12/070-S75G
	BUS004J	BUS004F		BUS005C
	BUS R06K1-XB-02/015-S75G	BUS R06K1-XB-05/024-S75G		BUS R06K1-XB-12/070-S75G

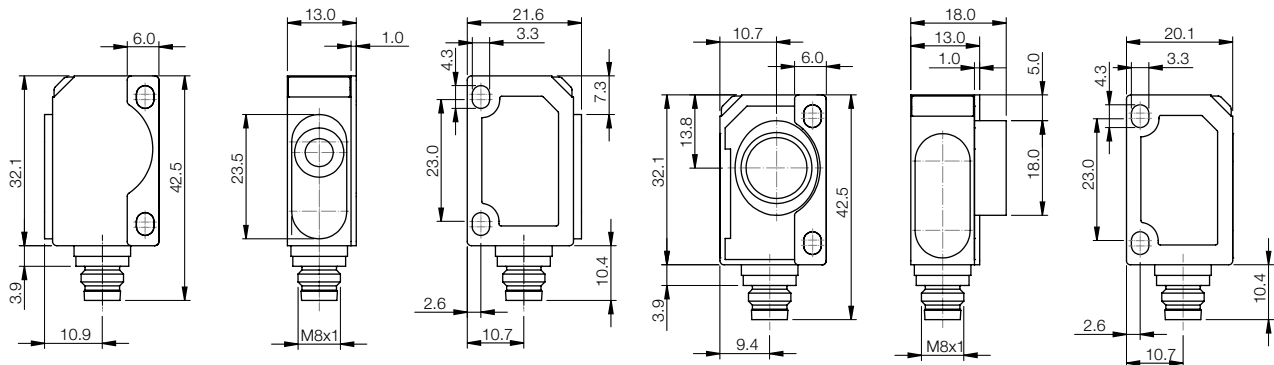

Operating scanning ranges 20–70 mm and 20–150 mm

Operating scanning range 120–700 mm

Suitable connector:

For standard connectors

Size	Design	Cable	Length	Order code
M8, 4-pin	straight	PUR, yellow	5 m	BCC0540
M8, 4-pin	angled	PUR, yellow	5 m	BCC059T

For optional shielded connectors

Size	Design	Cable	Length	Order code
M8, 4-pin	straight	PUR, black	5 m	BCC02N6
M8, 4-pin	angled	PUR, black	5 m	BCC02NJ

Recommended accessories

Description	Ordering code
Mounting tab	Included
Focusing attachment	BAM01YU
Mounting bracket	BAM00UH

For additional electrical accessories refer to our **Industrial Networking and Connectivity** catalog.

For additional mechanical accessories refer to our website.

Ultrasonic Sensors

M12 tubular-style housing

Features and benefits

- **Stainless steel housing**
- **Measuring range from 25 mm to 200 mm**
- **1 switching output in PNP or NPN design**
- **Teach-in via line (PIN 2)**

General data

Supply voltage	18...30 V DC, polarity reversal protected	
Output current	100 mA	
Resolution	0.2 mm	
Degree of protection as per EN 60529	IP 65	
Operating temperature	-20...+70°C	
Material	Housing	V2A, plastic parts: PA
	Sensing surface	Epoxy resin - hollow-glass sphere /PUR
Connection	M12 connector,4-pin	

Scanning range	25...200 mm
Blind zone	25 mm

BUS M12E switching output

PNP, NO/NC contact	Ordering code	BUS0005
	Part number	BUS M12E0-PPXCR-020-S04G
NPN, NO/NC contact	Ordering code	BUS0006
	Part number	BUS M12E0-NPXCR-020-S04G

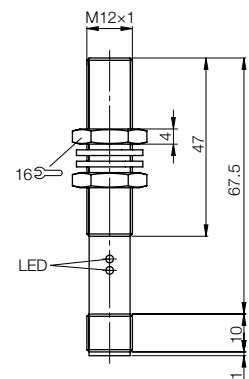

Suitable connector

Size/style	Length/cable material	Ordering code
M12, 4-pin/straight	5 m/PUR	BCC05FE
M12, 4-pin/angled	5 m/PUR	BCC05TC

For additional electrical accessories refer to our **Industrial Networking and Connectivity** catalog.

Recommended accessories

Description	Ordering code
Mounting cuff	BAM00C4
Mounting clamp	BAM01KM
Mounting bracket	BAM00C0
Focusing attachment	BAM01ET

For additional mechanical accessories refer to our website.



Monitoring of packages

Strict hygienic requirements in the food industry place special demands on sensor technology. The ultrasonic sensor reliably monitors the proper sealing of packages and thereby ensures uniform quality.



Features and benefits

- Measuring range from 600 mm to 6000 mm
- 2 switching outputs in PNP- or NPN-design
- Analog output 4...20 mA or 0...10 V
- Teach-in via line (PIN 5)

General data

Supply voltage	18...30 V DC, polarity reversal protected	
Output current	500 mA	
Resolution	1 mm	
Degree of protection as per EN 60529	IP 65	
Operating temperature	-15...+70°C	
Material	Housing	PBT
	Sensing surface	Epoxy resin - hollow-glass sphere /PUR
Connection	M12 connector, 5-pin	

Scanning range	600...6000 mm
Blind zone	600 mm

BUS Q80K switching output

2x PNP, NO/NC contact	Ordering code	BUS000A
	Part number	BUS Q80K0-PWXER-600-S92K
2x NPN, NO/NC contact	Ordering code	BUS000C
	Part number	BUS Q80K0-NWXER-600-S92K

BUS Q80K analog output

0...10 V	Ordering code	BUS000E
	Part number	BUS Q80K0-XAER-600-S92K
4...20 mA	Ordering code	BUS000F
	Part number	BUS Q80K0-XBER-600-S92K

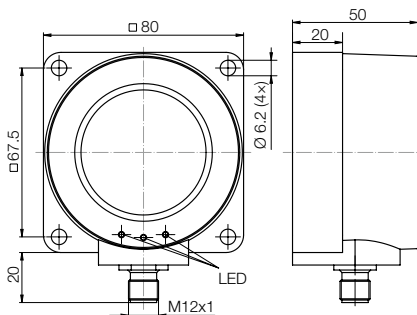

Suitable connector

Size/style	Length/cable material	Ordering code
M12, 5-pin/straight	5 m/PUR	BCC098C
M12, 5-pin/angled	5 m/PUR	BCC08FC
For optional shielded connector		
M12, 5-pin/straight/shielded	5 m/PUR	BCC08KP

For additional electrical accessories refer to our **Industrial Networking and Connectivity** catalog.

Fill-level monitoring in silos

The fill level of bulk materials in a container is detected by a continuous measurement with ultrasonic sensors. The fill level can be monitored with an analog output signal or with two switching signals – as min./max value.





Systems and Services



Industrial Networking and Connectivity



Industrial Identification



Object Detection



Linear Position Sensing and Measurement



Fluid Sensors



Accessories

USA

Balluff Inc.
8125 Holton Drive
Florence, KY 41042
Phone: (859) 727-2200
Toll-free: 1-800-543-8390
Fax: (859) 727-4823
E-Mail: balluff@balluff.com

Canada

Balluff Canada, Inc.
2840 Argentic Road, Unit #2
Mississauga, Ontario L5N 8G4
Phone: (905) 816-1494
Toll-free: 1-800-927-9654
Fax: (905) 816-1411
E-Mail: balluff.canada@balluff.ca

Mexico

Balluff de México SA de CV
Anillo Vial II Fray Junípero Serra No. 4416
Colonia La Vista Residencial.
Querétaro, Qro. CP76232
Phone: (+52 442) 212-4882
Fax: (+52 442) 214-0536
E-Mail: balluff.mexico@balluff.com