



# Butterfly valves Products

## CATALOG



## BUTTERFLY VALVE FEATURES AND APPLICATIONS

1. **One-piece cast body:** Cast in both wafer and tapped-lug patterns in a wide variety of material choices, the most durable butterfly Valves feature a one-piece body for minimum weight and maximum strength.
2. **Dry stem journal:** The unique stem hole design in the disc ensures a dry stem journal and the hard-backed seat allows ease of installation, reliable operation, and are available in sizes 2 in. through 12 in.(50 mm through 300 mm).
3. **Bi-directional sealing:** The valves provide bi-directional bubble-tight sealing at full rated pressure with identical flow from either direction.
4. **Integral flange seal:** Molded into the edge of the seat is an integral flange seal which accommodates ASME weld neck, slip-on, threaded and socket flanges as well as “stub end type C” flanges.
5. **ASME Class 150 rating:** Body rating is ASME Class 150. Wafer body diameters are designed to self-center in ASME Class 150 flange patterns.

Engineered for long-term, maintenance-free performance, the butterfly valves are commonly selected for a variety of applications spanning a wide range of industries:

**Oil and gas drilling and production Mining and materials Dry bulk handling Water and waste water  
Chemical and petrochemical Agriculture Marine and government Power Cooling towers (HVAC)**

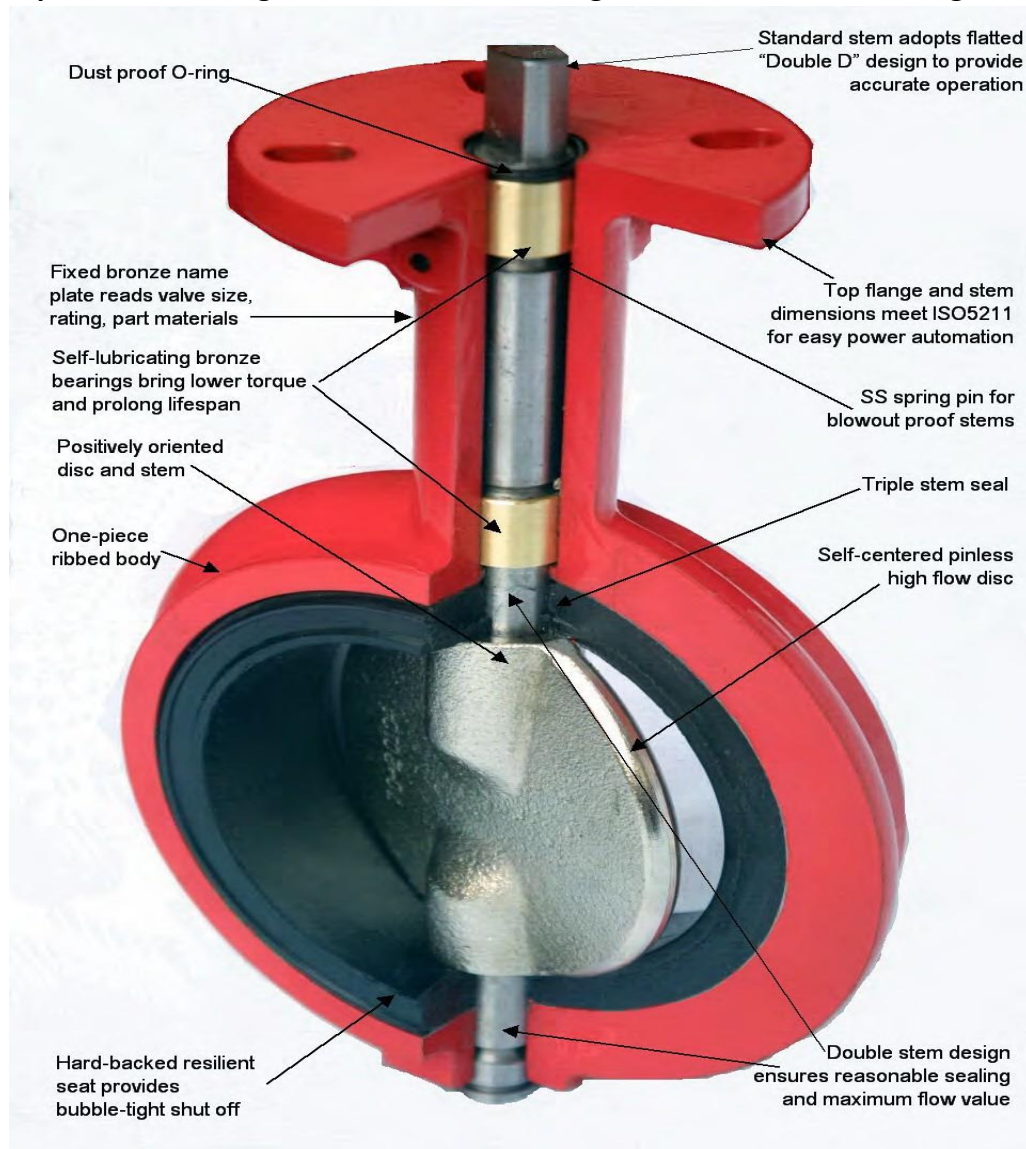

## BUTTERFLY VALVE FEATURES

### Standard Pressure Ratings

Standard drop tight pressure rating is offered for 2 in. to 12 in. (50 mm to 300 mm) sizes. The standard shut-off pressure rating is 200 psi, alternative shut-off ratings are also available for different working conditions to significantly reduce overall installation cost in automated applications.

### A. Dry stem journal eliminates potential for leakage

The butterfly valve disc is uniquely designed with a continuous annular raised land around the stem hole and disc edge which presses into the seat flat at every angular position. The resilient seat presses back with a higher specific force than the line pressure, preventing leakage to the stem. In addition, two O-ring ribs are provided in the seat stem bore creating a triple stem seal. In competitive stem seal designs with boot seats, a seal is accomplished by an interference “squeezing” on the stem or an O-ring in the stem journal. The potential for leakage behind the seat is high for this competitive design. As the disc wipes the seat, elongation of the stem seal area allows leakage to collect behind the seat. This condition is eliminated by the dry stem journal and hard-backed seat.

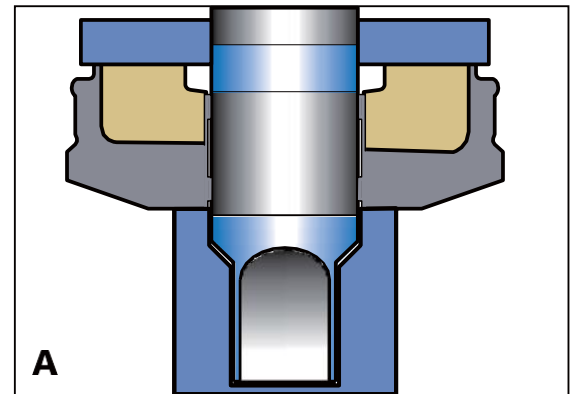

### B. Hard-backed Cartridge Seat

The cartridge seat is constructed by permanently bonding a resilient elastomer to a rigid backing ring. In addition to superior sealing integrity, this design;

- 1) makes valve installation easier because no special precautions are required for disc position. This is especially advantageous when installing valves with fail closed actuators;
- 2) eliminates high torque and premature failure caused by elastomer distortion as found in other non-rigid seat designs;
- 3) simplifies seat replacement because it is slip fitted into the body, with no need for special tools.

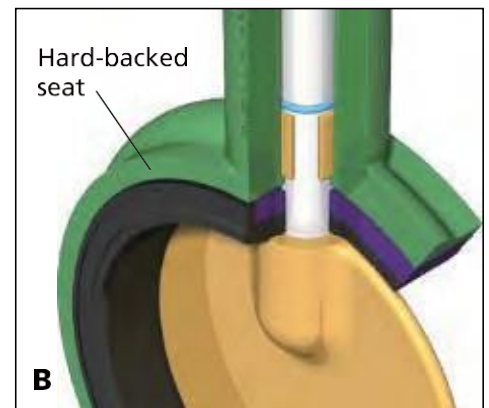

### C. Positively Oriented Disc

Proper orientation of the stem/disc connection is assured by the rectangular drive. In 2 in. through 12 in. (50 mm through 300 mm) size valves, the disc is permitted to float on the stem to perfectly center in the valve seat. This design enhances drop-tight sealing and prolongs service life.

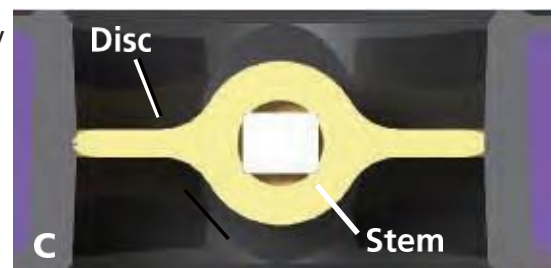

## BUTTERFLY VALVE FEATURES AND SPECIFICATIONS

### D. End-of-line Service

Lug body valves may be used in end-of-line service, with downstream piping removed. (Only weld neck or socket flanges can be used for this service). Since upstream pressure is excluded between the flange and the seat face by the exclusive flange seal design, there is no effective force to slide the seat downstream. Lug butterfly valves 2 in. through 12 in. (50 mm through 300 mm) are suitable for liquid service up to 200 psi with downstream piping removed. Lug body valves are recommended for isolation of pumps, control devices or other system components which may need to be removed for repair or replacement. Lug valves are also suitable for installation at points from which piping expansion may proceed. Such valves are normally blanked with blind flanges, to protect the exposed seats until new piping is attached.

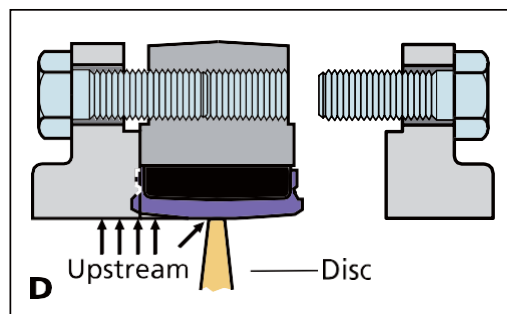

### Specifications

Sizes: 2 in. through 12 in. (50 mm through 300 mm)

Body type and style designations:

Long neck : 2 in. through 12in. (50 mm through 300 mm), including wafer / lug type.

Short neck: 2 in. through 12 in. (50 mm through 300 mm), wafer type only.

Pressure rating: 200Psi for 2 in. through 12 in. (50 mm through 300 mm)

Operating Temperatures:

-30oF to 300oF (-34oC to 204oC) depending on seat material selection and application

Standard Material Options:

Bodies: cast iron, ductile iron, WCB

Discs: Nickel plated ductile iron, bronze and stainless steel, nylon coated ductile iron

Stems: 416 and 316 stainless steel

Seats: Buna-N, VITON, EPDM

The Resilient Seated Butterfly Valves are an economical alternative to ball, gate or plug valves in many applications. They are light weight quarter turn devices with few parts. They are designed for bubble-tight sealing up to rated pressure and are capable of throttling service.

They are easily adapted to automatic actuators. The Resilient Seated Butterfly Valve is available in flangeless wafer design or single flange tapped lug configuration.



## PRESSURE RATING

Three drop tight pressure ratings are offered for Butterfly Valves. Normally, 200 psi shutoff is used in butterfly applications. However, 285 psi shutoff is optionally available for higher pressure applications. For smaller actuator sizing, 50 psi valves offer reduced torque.

For minimum torque, throttling valves, which do not provide drop tight closure, are available.

## END-OF-LINE SERVICE

Lug body valves may be used in end-of-line service, with downstream piping removed. (Weld neck or socket flanges, only can be used for this service). Since upstream pressure is excluded between the flange seal, there is no effective force to slide the seat downstream.

Lug Butterfly Valves are recommended for liquid service up to 200 psi with downstream piping removed.

Lug body valves are recommended for isolation of pumps, control devices, or other system components which may need to be removed for repair or replacement. Lug valves are also suitable for installation at points from which piping expansions may proceed. Such valves are normally blanked with blind flanges, to protect the exposed seats, until new piping is attached.

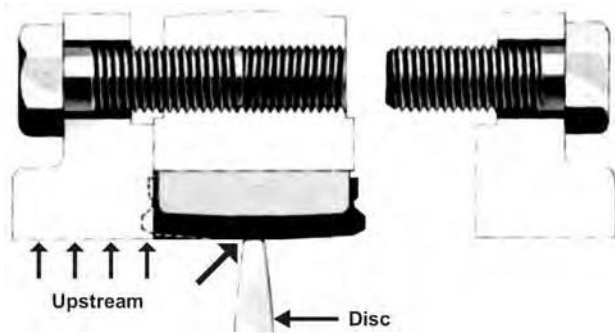

## ACTUATION

Positive latch handles, worm gear operators, and automatic actuators are available and totally inter-changeable on the valve.

valve to flange is dimensionally compatible with other competitive butterfly valves. With optional "utility top" stem, the valve interchange directly with competitive valves, allowing valve replacement without the need for new actuation.

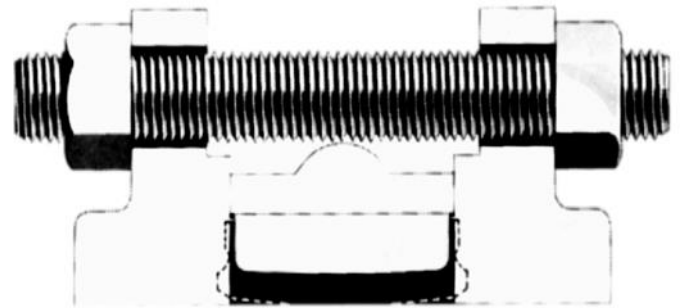

## INSTALLATION AND MAINTENANCE

**Butterfly Valves** are bi-directional, with identical flow-way from either face. To install, simply close the valve, insert between flanges and make up with studs or cap screws. No regular maintenance or lubrication is ever required. Disassembly is simple, for inspection or replacement of parts. Open the valve, remove handle or actuator, remove tangential pins, pull out stems and push the disc and seat out of the body. Reassemble in reverse order, with a small amount of general purpose non-hydrocarbon based lubricant on the outside of stems, seat, and disc flats.

Steel or cast iron flanges of either raised or flat-faced type are suitable for use with

**Butterfly Valves.**

# ORDERING INFORMATION FOR NE

## VALVE ASSEMBLY PART NUMBER

A base part number defines series, size, and shutoff pressure, and is followed by a 7-digit suffix which specifies all options, including handles.

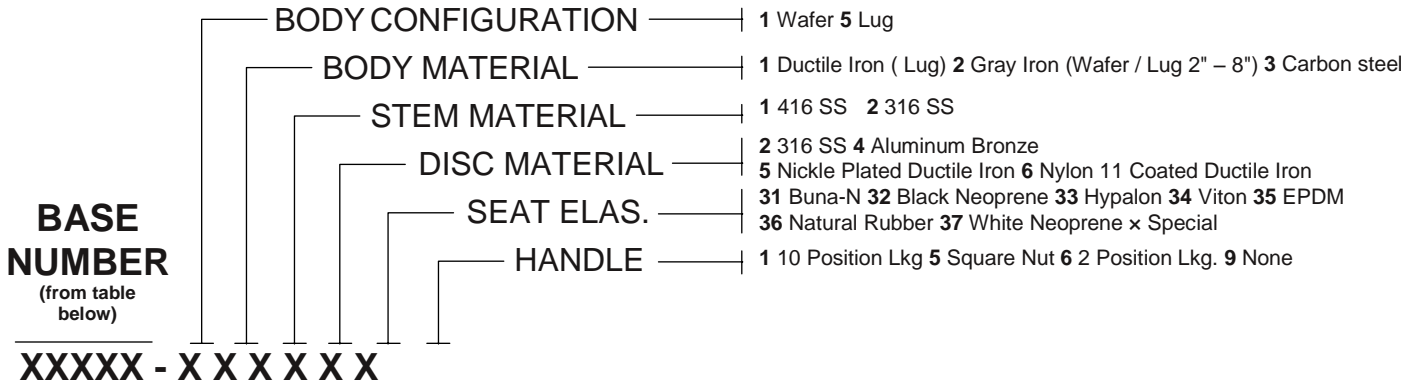

COMPONENT DESCRIPTION		2"	2½"	3"	4"	5"	6"	8"	10"	12"
NE-C	200 psi	K 22119	K 22120	K 22121	K 22122	K 22123	K 22124	K 22125	K 22126	K 22127
WEIGHT LBS.	Wafer	5.8	7.0	7.7	11.4	14.7	17.6	28.5	47.9	71.0
	Lug	8.0	9.9	10.7	17.0	24.5	28.5	43.5	65.9	98.5
NE-D	200 psi	K22181	K 22129	K22182	K22183	K22184	K22185	K 22134	K22186	K 22136
Weight (lbs. - bare stem)	Wafer	4.9	6.4	6.9	10.2	13.7	16.4	28.4	44.8	66.8

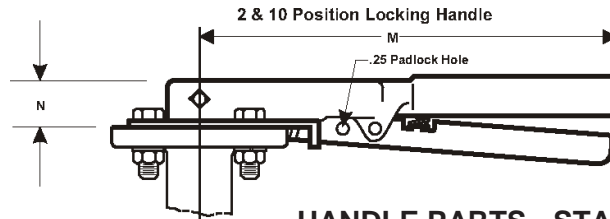

HANDLE PARTS - STANDARD TRIM

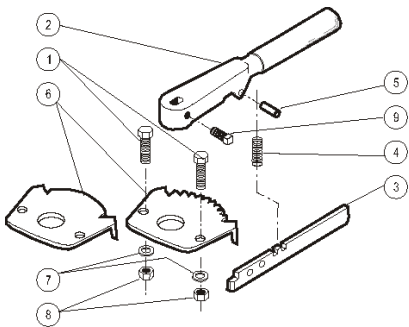

REF NO.	COMPONENT DESCRIPTION	2" – 4"	5" – 6"	8"	10"	12"
	ASSY. BASE PART NO. -10 POSITION	K24227-001	K24228-001	K24229-00	K24230-001	K24231-001
	-2 POSITION	K24232-001	K24233-001	K24234-001	K24235-001	K24236-001
1	SCREW Steel	K5650-24020		K5650-28024		
2	HANDLE Ductile Iron	K24237-001	K24238-001	K24239-001	K24240-001	K24241-001
3	LATCH Zinc Plated Steel	K23719-001	K23720-001	K23721-001		
4	SPRING Spring Steel	K16238				
5	SPRING PIN Spring Steel	K5445-25014		M5446-37516		
6	THROTTLE PLATE -10 POSITION	K24242-001	K24243-001	K24244-001	K24245-001	K24246-001
	-2 POSITION	K24247-001	K24248-001	K24249-001	K24250-001	K24251-001
7	LOCK WASHER Steel	K5900-006		K5901-008		
8	NUT Zinc Plated Steel	K5327-024		K5327-028		
9	SET SCREW Steel	K5727-22012		K5727-22016		
	DIMENSIONS M	9.50	11.00	15.00	15.00	22.00
	N	0.85	1.07	1.13	1.13	1.13
	HANDLE WEIGHTS (lbs) 2 or 10 Pos. Lkg.	2	3	5	5	9

## REPLACEMENT PARTS FOR THE NE STYLE

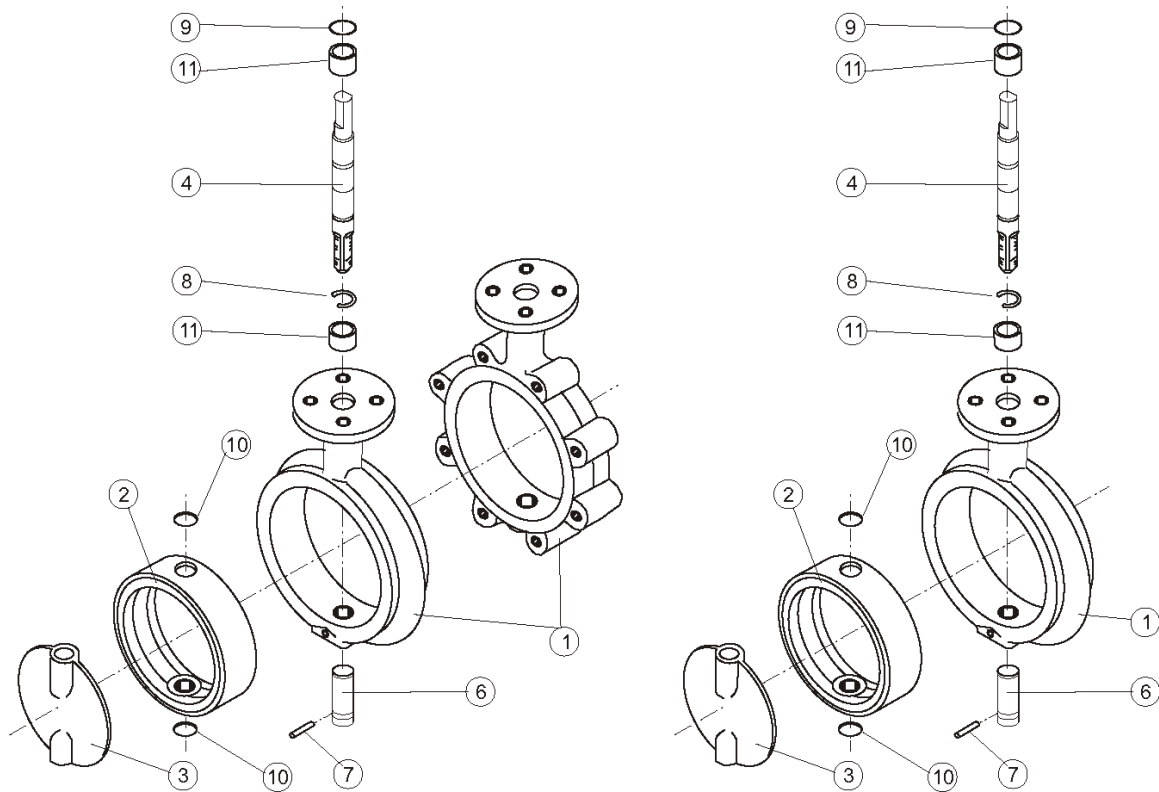

REF NO.	COMPONENT DESCRIPTION	2"	2½"	3"	4"	5"	6"	8"	10"	12"	
1	BODY	NE-C Wafer	K22137-012	K22138-012	K22139-012	K22140-012	K22141-012	K22142-012	K22143-012	K22144-012	K22145-012
			ASTM A48 Gray Iron -012								
		NE-C Lug	K21986-05x	K21987-05x	K21988-05x	K21989-05x	K21990-05x	K21991-05x	K21992-05x	K21993-051	K21994-051
		Options	ASTM A395 Ductile Iron -051, ASTM A48 Gray Iron -052								
		NE-D Wafer	K22187-021	K22682-011	K22188-021	K22189-021	K22190-021	K22191-021	K22687-011	K22688-011	K22689-011
2	SEAT		K1786-xxx	K1788-xxx	K1790-xxx	K1792-xxx	K1794-xxx	K1002-xxx	K1798-xxx	K1815-xxx	K1817-xxx
		Options	-031 Buna-N -032 Blk. Neoprene -033 Hypalon -034 Viton								
			-035 EPT -036 Nat. Rubber -037 While Neoprene -x Special								
3	DISC	200 psi	K22045-0xx	K22046-0xx	K22047-0xx	K22048-0xx	K22049-0xx	K22050-0xx	K22051-0xx	K22052-0xx	K22053-0xx
		Options	-002 316 SS -005 Ni. Plated Duct Iron -014 Alum. Bronze								
4	UPPER STEM	NE-C	K22066-00x	K22067-00x		K22068-00x	K22069-00x	K22070-00x	K22071-00x	K22072-00x	
		NE-D	K22073-00x	K22074-00x	K22193-00x	K22194-00x	K22195-00x	K22077-00x	K22078-00x	K22079-00x	
6	LOWER STEM		K22080-66x	K22081-00x		K22082-00x	K22083-00x	K22084-00x	K22085-00x	K22086-00x	
		Options	-001 416 SS -002 316 SS -004 Phos. Coated Steel								
7	SPRING PIN (2)	302 SS	K5448-18720			K5448-18724			K5448-25028		
8	RETAINER	Stainless Steel	K22117		K13704		K13705		K13706	K13707	
9	TOP O-RING	Buna-N	K5526-114		K5526-115		K5526-117		K5526-119	K5526-125	
10	STEM O-RING	Buna-N	K5526-113	K5526-115		K5526-116		K5526-212		K5526-214	K5526-220
11	BEARING	Bronze	K22526-001	K22118-001		K13112-001		K13115-001		K13116-001	K13117-001

# SERIES NE-C STYLE 2"- 12" ENGINEERING

THE NE-C STYLE BUTTERFLY VALVES ARE OFFERED IN WAFER OR LUG DESIGN WHICH MOUNT IN BETWEEN ANSI 125/150 FLANGES

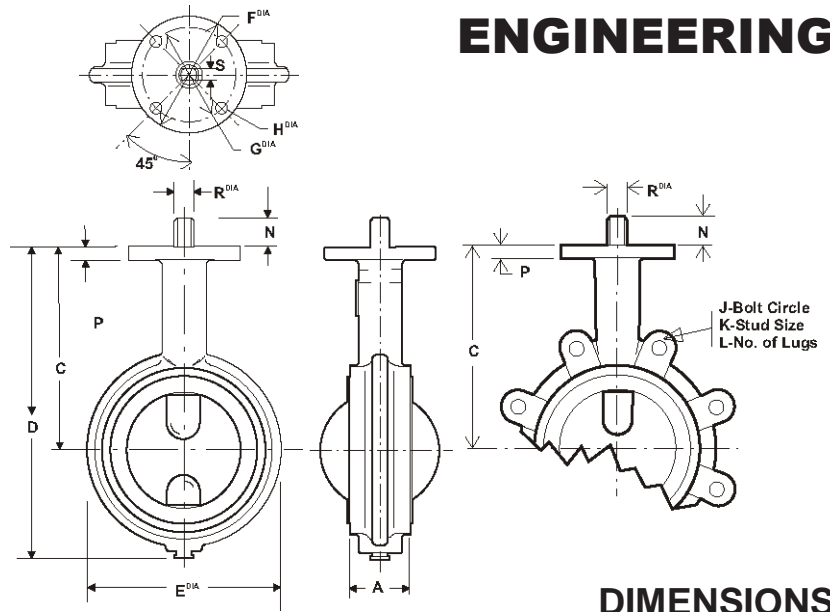

## DIMENSIONS

VALVE SIZE	A	C	D	E	F	G	H	J	K	L	N	P	R	S
2"	1.74	5.62	8.44	4.12	4.00	3.25	.408	4.75	5/8 - 11	4	1.00	.44	.625	.375
2½"	1.86	6.12	9.19	4.88	4.00	3.25	.408	5.50	5/8 - 11	4	1.00	.44	.625	.375
3"	1.86	6.38	9.69	5.36	4.00	3.25	.408	6.00	5/8 - 11	4	1.00	.44	.625	.375
4"	2.11	7.12	11.00	6.88	4.00	3.25	.408	7.50	5/8 - 11	8	1.00	.44	.625	.375
5"	2.24	7.75	12.12	7.75	4.00	3.25	.408	8.50	3/4 - 10	8	1.25	.44	.838	.500
6"	2.24	8.25	13.25	8.75	4.00	3.25	.408	9.50	3/4 - 10	8	1.25	.44	.838	.500
8"	2.54	9.44	15.56	11.00	6.00	5.00	.533	11.75	3/4 - 10	8	1.38	.56	.838	.500
10"	2.74	11.25	18.69	13.38	6.00	5.00	.533	14.25	7/8 - 9	12	1.38	.56	.963	.625
12"	3.24	12.19	21.69	16.12	6.00	5.00	.533	17.00	7/8 - 9	12	1.38	.56	1.338	.750

## CLASS II

### TORQUES (Inch - Pounds)

Shutoff Pressure	2"	2½"	3"	4"	5"	6"	8"	10"	12"
50 PSI SHUTOFF	88	96	150	225	350	450	750	1325	2250
75 PSI SHUTOFF	98	141	237	243	504	651	1050	1778	2990
100 PSI SHUTOFF	103	148	249	261	531	685	1105	1872	3147
125 PSI SHUTOFF	107	155	260	375	553	714	1151	1950	3279
150 PSI SHUTOFF	110	158	265	384	564	728	1175	1989	3345
175 PSI SHUTOFF	121	175	283	417	632	814	1337	2320	3928
200 PSI SHUTOFF	132	192	300	450	700	900	1500	2650	4500
250 PSI SHUTOFF	145	211	318	485	770	990	1695	2995	5085
285 PSI SHUTOFF	160	232	337	528	847	1089	1915	3384	5746

Value Size	10°	20°	30°	40°	50°	60°	70°	80°	90°
2"	2	5	10	18	28	55	77	127	153
2½"	3	7	14	24	41	87	115	186	242
3"	4	12	23	37	66	129	186	274	337
4"	6	24	44	76	125	241	312	521	601
5"	8	32	87	158	257	298	632	983	1122
6"	9	52	148	244	413	786	1028	1633	1949
8"	12	101	246	418	693	1279	1732	2702	3232
10"	21	165	393	667	1144	2140	2744	4276	4979
12"	28	233	555	992	1588	3096	4044	6048	7481

### Class II

- > Valve to be operated a minimum of once a month.
- > Temperature wall within resilient seat limits.
- > Line media is a self lubricating (Aqueous liquids) \*.
- > Minor chemical attacks on seat.
- > Disc corrosion and media deposits to be mild.

### Notes:

1. The chart to be used as a guide only.
2. These torque rating do not apply to every possible service criteria, which may affect seating and unseating torque.
3. Torque values are applicable to NE-C values.
4. Do not apply a safety factor to the above torque values when sizing actuators.
5. Dynamic Torque should always be a consideration when sizing valves with high differential pressures.
6. For 3 way tee assemblies multiply the above torques by 1.5.

TYPE COMPOUND	TYPE OF SERVICE	TEMPERATURES
Buna-N	General purpose elastomer compound for maximum hydrocarbon or petroleum.	0° F – 180° F
Black Neoprene	Complies with FDA guidelines and generally used in food and beverage service and resistant to brine, vegetable oils, and oxygen.	0° F – 180° F
White Neoprene	Same chemical resistant as black neoprene in physical properties are not as good as black. White neoprene should only be used when black cannot be tolerated and storage should be in low light conditions.	0° F – 180° F
Viton	Excellent in harsh chemical environments and elevated temperatures.	+20° F – 300° F
Hypalon	Excellent in acids and hydrocarbons and very high chemical resistant.	0° F – 180° F
Natural Rubber	Recommended for dry material handling and high abrasion resistance. Use in oils and solvents not recommended.	+30° F – 150° F
EPDM	Formulated to comply with FDA guidelines, this material is suitable for food service except edible oils and milk.	+30° F – 275° F



The NE D Series butterfly valves are designed short neck with body notched to fit lightweight flanges and for working areas of limited space. They are specially ideal for mining, dry bulk material handling, transportation.

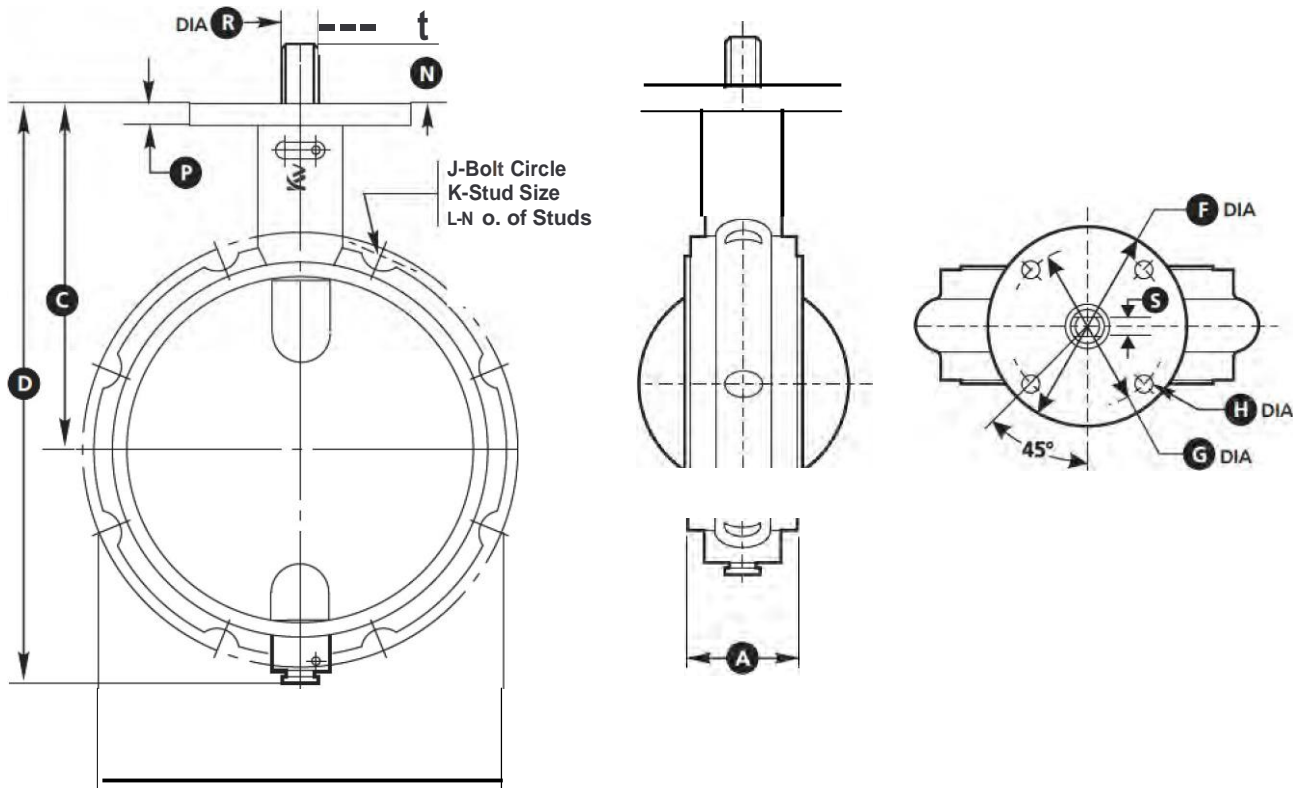

### Materials of Construction

No.	Description	Material
1	Body	Cast Iron ASTM A126, Ductile Iron ASTM A536, WCB Gr 216*
2	Disc	Ductile Iron (N! Plated), Aluminum Bronze, CF8M (316 SS), CF8 (304 SS), Ductile Iron (Nylon Coated)*
3	Stem	416 Stainless Steel, 304 Stainless Steel, 316 Stainless Steel, Monel*
4	Seat	BUNA-N, EPDM, FKM(Viton)
5	Retainer Pin	ASTM Gr. 1065 Steel
6	O-ring	BUNA-N (Viton Optional)
7	Bushing	Aluminum Bronze, PTFE

\* Asterisk denotes factory availability only

### DIMENSIONAL DATA

Size in.	A	E	D	E	F	G	H	J	K	L	N	P	R	S
2	1.74	3.94	6.75	4.12	4.00	3.25	0.408	4.27	3/8	4	1.00	0.44	0.625	0.375
	1.86	4.44	7.50	4.88	4.00	3.25	0.408	5.31	3/8	4	1.00	0.44	0.625	0.375
3	1.86	4.88	8.19	5.38	4.00	3.25	0.408	4.91	3/8	6	1.00	0.44	0.625	0.375
4	2.11	6.00	9.88	6.88	4.00	3.25	0.408	7.03	1/2	6	1.00	0.44	0.625	0.375
5	2.24	6.00	10.38	7.75	4.00	3.25	0.408	7.56	1/2	6	1.25	0.44	0.838	0.500
6	2.24	6.50	11.50	8.75	4.00	3.25	0.408	9.16	1/2	8	1.25	0.44	0.838	0.500
8	2.54	8.06	14.19	11.00	6.00	5.00	0.533	11.72	5/8	8	1.38	0.56	0.838	0.500
10	2.74	9.97	17.41	13.38	6.00	5.00	0.533	13.72	5/8	8	1.38	0.56	0.963	0.625
12	3.24	10.91	20.41	16.12	6.00	5.00	0.533	16.62	1/2	12	1.38	0.56	1.338	0.750

are designed for installation between ASJv1E Class125/150 flanges.

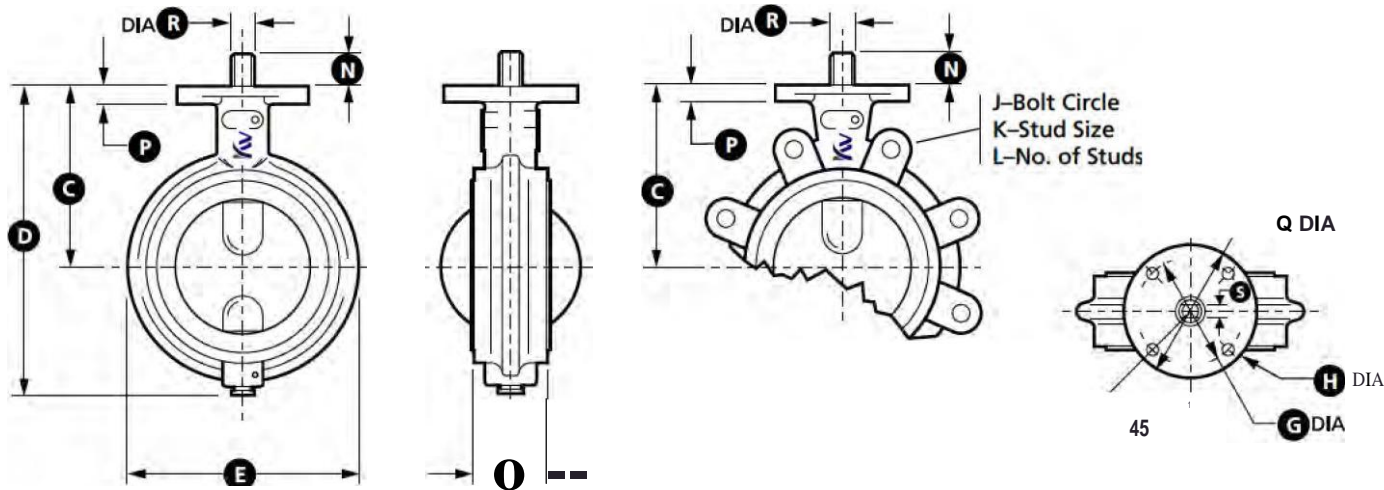

### Dimensional Data

Size in	A	C	D	E	F	G	H	I	K	L	N	P	R	S
2	1.74	3.94	6.75	4.12	4.00	3.25	0.408	4.75	518-11	4	1.00	0.44	0.625	0.375
2-112	1.86	4.44	7.50	4.88	4.00	3.25	0.408	5.50	5/8-11	4	1.00	0.44	0.625	0.375
3	1.86	4.69	8.00	5.38	4.00	3.25	0.408	6.00	518-11	4	1.00	0.44	0.625	0.375
4	2.11	5.44	9.31	6.88	4.00	3.25	0.408	7.50	5/8-11	8	1.00	0.44	0.625	0.375
5*	2.24	6.38	10.75	7.75	4.00	3.25	0.408	8.50	3/4-10	8	1.25	0.44	0.838	0.500
6	2.24	6.88	11.88	8.75	4.00	3.25	0.408	9.50	3/4-10	8	1.25	0.44	0.838	0.500
8	2.54	8.06	14.19	11.00	6.00	5.00	0.533	11.75	314-10	8	1.38	0.56	0.838	0.500
10	2.74	9.97	17.41	13.38	6.00	5.00	0.533	14.25	718-9	12	1.38	0.56	0.963	0.625
12	3.24	10.91	20.41	16.12	6.00	5.00	0.533	17.00	7/8-9	12	1.38	0.56	1.338	0.750
Size mm	A	C	D	E	F	G	H	I	K	L	N	P	R	S
50	44	100	171	105	102	83	10.36	121	5/8-11	4	25	11.2	15.88	9.53
65	47	113	191	124	102	83	10.36	140	518-11	4	25	11.2	15.88	9.53
80	47	119	203	137	102	83	10.36	152	518-11	4	25	11.2	15.88	9.53
100	54	138	236	175	102	83	10.36	191	518-11	8	25	11.2	15.88	9.53
125*	57	162	273	197	102	83	10.36	216	314-10	8	32	11.2	21.29	12.70
150	57	175	302	222	102	83	10.36	241	3/4-10	8	32	11.2	21.29	12.70
200	65	205	360	279	152	127	13.54	298	3/4-10	8	35	14.2	21.29	12.70
250	70	253	442	340	152	127	13.54	362	718-9	12	35	14.2	24.46	15.88
300	82	277	518	409	152	127	13.54	432	718-9	12	35	14.2	33.99	19.05

### Materials of Construction

No.	Description	Material
1	Body	Cast Iron ASTM A126, Ductile Iron ASTM A536, WCB Gr 2 16, Stainless steel*
2	Disc	Ductile Iron (NIP la te d), Aluminum Bronze, CF8M (3 16 SS), CF8 (30 4 SS), Ductile Iron (Ny lon Coated)*
3	Stem	416 Stainless Steel, 30 4 Stainless Steel, Monel
4	Seat	BUNA-N, EPDM, FKM(Viton)
5	Retainer Pin	ASTM Gr. 1065 Steel
6	O-ring	BUNA-N (Viton Optional)
7	Bushing	Aluminum Bronze, PTFE

\* Asterisk denotes factory availability only



#### Brazil Office

Seven Oceans Habitat Offshore Co., Limited

Tel: +55 21 4063 6342

Address: Engenheiro Haroldo Cavalcante, 360 G 305 Recreio dos Bandeirantes

Rio de Janeiro

Post Code: 22795-240

#### China Office

Seven Oceans Habitat Offshore Co., Limited

Tel: 0411-3973 1871 / 3973 1872 / 3973 1873

Fax: 0411-3973 1875

Address: NO. 76&78 Hui Xin Street, Gan Jing Zi District, Dalian, China

地址: 大连市甘井子区汇信街76-78号

Post Code: 116091

E-mail: [contacts@7oceanshabitat.com](mailto:contacts@7oceanshabitat.com)

Website: [www.7oceanshabitat.com](http://www.7oceanshabitat.com)