

Flow



# BWT™ System

Installation Guide





# BWT™ System

## Bundle Waveguide Technology™ Flow Transducer System

### Installation Guide

916-058 F  
July 2021

[panametrics.com](http://panametrics.com)

Copyright 2021 Baker Hughes company.

This material contains one or more registered trademarks of Baker Hughes Company and its subsidiaries in one or more countries. All third-party product and company names are trademarks of their respective holders.

[no content intended for this page]

---

## Information Paragraphs

**Note:** These paragraphs provide information that provides a deeper understanding of the situation, but is not essential to the proper completion of the instructions.

**IMPORTANT:** These paragraphs provide information that emphasizes instructions that are essential to proper setup of the equipment. Failure to follow these instructions carefully may cause unreliable performance.



**CAUTION!** This symbol indicates a risk of potential minor personal injury and/or severe damage to the equipment, unless these instructions are followed carefully.



**WARNING!** This symbol indicates a risk of potential serious personal injury, unless these instructions are followed carefully.

## Safety Issues



**WARNING!** It is the responsibility of the user to make sure all local, county, state and national codes, regulations, rules and laws related to safety and safe operating conditions are met for each installation.



**WARNING!** For installations in potentially hazardous areas, be sure to read the *Certification and Safety Statements* document at the end of this manual before beginning the installation.

## Auxiliary Equipment

### Local Safety Standards

The user must make sure that he operates all auxiliary equipment in accordance with local codes, standards, regulations, or laws applicable to safety.

### Working Area



**WARNING!** Auxiliary equipment may have both manual and automatic modes of operation. As equipment can move suddenly and without warning, do not enter the work cell of this equipment during automatic operation, and do not enter the work envelope of this equipment during manual operation. If you do, serious injury can result.



**WARNING!** Make sure that power to the auxiliary equipment is turned OFF and locked out before you perform maintenance procedures on the equipment.

## Qualification of Personnel

Make sure that all personnel have manufacturer-approved training applicable to the auxiliary equipment.

## Personal Safety Equipment

Make sure that operators and maintenance personnel have all safety equipment applicable to the auxiliary equipment. Examples include safety glasses, protective headgear, safety shoes, etc.

## Unauthorized Operation

Make sure that unauthorized personnel cannot gain access to the operation of the equipment.

## Environmental Compliance

### Waste Electrical and Electronic Equipment (WEEE) Directive

Baker Hughes is an active participant in Europe's *Waste Electrical and Electronic Equipment (WEEE)* take-back initiative, directive 2012/19/EU.



The equipment that you bought has required the extraction and use of natural resources for its production. It may contain hazardous substances that could impact health and the environment.

In order to avoid the dissemination of those substances in our environment and to diminish the pressure on the natural resources, we encourage you to use the appropriate take-back systems. Those systems will reuse or recycle most of the materials of your end life equipment in a sound way.

The crossed-out wheeled bin symbol invites you to use those systems.

If you need more information on the collection, reuse and recycling systems, please contact your local or regional waste administration.

Visit [www.bakerhughesds.com/health-safetyand-environment-hse](http://www.bakerhughesds.com/health-safetyand-environment-hse) for take-back instructions and more information about this initiative.

**Chapter 1. General Information**

1.1 Introduction .....1

1.2 Types of BWT Buffers.....1

1.3 General Guidelines for Transducer Position and Location..... 2

1.4 BWT Meter Body ..... 3

    1.4.1 Single- Traverse Meter Body ..... 3

    1.4.2 Double- Traverse Meter Body..... 4

1.5 Handling and Installing a Meter Body..... 5

    1.5.1 Unpacking a Meter Body ..... 5

    1.5.2 Installing a Meter Body..... 5

1.6 Welding Requirements ..... 7

1.7 Meter Body Requirements When Flushing ..... 7

**Chapter 2. Standard Installation (FTP A Buffers)**

2.1 Introduction ..... 9

2.2 Identifying and Checking the Components..... 9

2.3 Assembling the Standard FTP A Buffer ..... 11

2.4 Inserting the Standard FTP A Buffer.....12

2.5 Installing the BWT Transducer ..... 16

    2.5.1 Installing and Orienting the Junction Box .....17

    2.5.2 Inserting the BWT Transducer ..... 18

    2.5.3 Verifying the Installation..... 19

**Chapter 3. Acoustic Isolation Installation (FIPA Buffers)**

3.1 Introduction .....21

3.2 Identifying and Checking the Components.....21

3.3 Inserting the Acoustic Isolation FIPA Buffer..... 23

3.4 Torquing the Studs ..... 27

3.5 Installing the BWT Transducer ..... 30

    3.5.1 Installing and Orienting the Junction Box ..... 30

    3.5.2 Inserting the BWT Transducer .....31

    3.5.3 Verifying the Installation..... 33

3.6 Installing Additional Acoustic Isolation ..... 33

**Chapter 4. Non-Flanged Installation (FSPA/FWPA Buffers)**

4.1 Introduction .....35

4.2 Installing the FSPA or FWPA Buffer.....36

4.3 Installing and Orienting the Junction Box..... 37

4.4 Inserting the BWT Transducers ..... 38

4.5 Verifying the Installation.....39

**Chapter 5. Specifications**

5.1 Transducers ..... 41

5.2 Flanged Buffer Assemblies ..... 41

5.3 Threaded Buffer Assemblies..... 42

5.4 Socket-Weld Buffer Assemblies ..... 42

5.5 System ..... 42





# Chapter 1. General Information

## 1.1 Introduction

Installing the Bundle Waveguide Technology™ (BWT™) System consists of creating a meter body, installing the transducer buffer, and then mounting transducers into the buffer. Panametrics offers a variety of buffers and meter bodies for liquid and gas applications. This section consists of general information for the following topics:

- Types of BWT buffers (see *page 1*)
- General guidelines for transducer position and location (see *page 2*)
- BWT meter body (see *page 3*)
- Handling and installing a meter body (see *page 5*)
- Welding requirements (see *page 7*)
- Meter body requirements when flushing (see *page 7*)

**IMPORTANT:** If the BWT buffers and transducers are used in a PanaFlow HT system, you must follow all instructions in the PanaFlow HT User's Manual (910-294U) and Safety Manual (917-025).

## 1.2 Types of BWT Buffers

Buffers are used to protect the BWT transducers from temperature extremes. Since they mount directly into the pipe coupling or nozzle, they also act as barriers against the process, making it possible for the transducers to be removed without interrupting the process or emptying the pipe.

**IMPORTANT:** The buffers also ensure that the service temperature of the transducers remains at ambient.

There are three BWT buffer types available for transducers for liquid and gas applications:

- Standard BWT Buffer (part number **FTP**) - is used for liquid and gas applications. The buffer has a flanged process connection and is available in two lengths: **2 in.** (temperatures up to 600°F/315°C) and **6 in.** (temperatures up to 1,100°F/600°C).
- Acoustic Isolation BWT Buffer (part number **FIPA**) - is used for gas applications at lower pressures. The buffer has a flanged isolation section that reduces acoustic short circuits. The outer buffer has a flanged process connection and is available in **two lengths: 2 in.** (temperatures up to 600°F/315°C) and **6 in.** (temperatures up to 1,100°F/600°C).

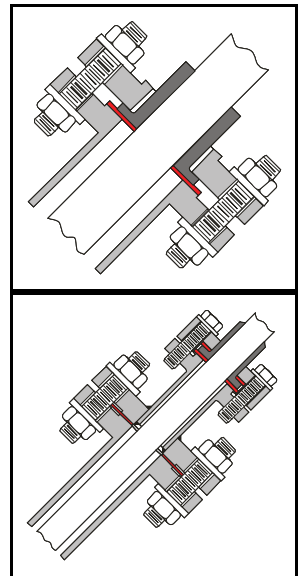

- Non-Flanged BWT Buffer (part number **FSPA**) - is used in liquid applications and has a 1 in. NPT thread.
- Socket-Weld BWT Buffer (part number **FWPA**) - is used in liquid applications and has a 1 in. coupling that is welded into the pipe coupling.

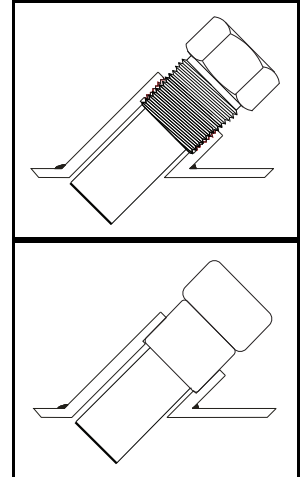

### 1.3 General Guidelines for Transducer Position and Location



**WARNING!** For installations in potentially hazardous areas, be sure to read the *Certification and Safety Statements* document at the end of this manual before beginning the installation.

Whichever transducer type is selected for your installation, flowmeter accuracy depends on proper transducer location, spacing, alignment, and electronics programming. However, even though every transducer installation has specific location considerations, the following location guidelines apply to all transducers, regardless of type:



**CAUTION!** A flowmeter's accuracy and performance depends on the location, spacing, and alignment of the transducers. The specific spacing of your transducers are unique to your installation.

1. To help assure a uniform flow profile, locate the buffers so that there are at least 10 pipe diameters of straight, undisturbed flow upstream and 5 pipe diameters of straight, undisturbed flow downstream from the point of measurement. The more straight run available the better. "Undisturbed flow" means avoiding sources of turbulence such as valves, flanges, and elbows. You should also avoid swirl, cross flow and cavitation (in liquids).
2. It is important to locate the transducers on a horizontal plane. This specifically applies to mounting transducers on a horizontal pipe. One transducer cannot be on top of the pipe and one on the bottom, because the top of the pipe tends to accumulate gas (in liquids) and the bottom tends to accumulate sediment (in gas and liquids). These contaminants can attenuate or block the ultrasonic signal. There is no similar restriction with vertical pipes. However, in liquid applications you should avoid vertical downward flow to ensure a full pipe.

## 1.4 BWT Meter Body

BWT installations typically use a tilted-diameter meter body. A tilted-diameter meter body is so named because the transducers send their pulses at an angle across the diameter of the pipe. This type of meter body can be configured as a single-traverse or double-traverse installation.

**Note:** The mounting angle for the transducer is typically 45°, but other angles (20°, 30°, or 60°) can be used as required. Tilted diameter can also refer to paths that are off-diameter such as the mid-radius path.

A **meter body** is created by mounting the nozzles on the existing pipeline, or on a **flowcell**. A flowcell is a precision-manufactured section of matching pipe that contains the ports where the transducer buffers will be mounted. This setup allows more accurate transducer alignment before mounting the meter body into the pipeline. If requested, a meter body can be calibrated prior to shipment. All meter bodies are factory-supplied.

### 1.4.1 Single-Traverse Meter Body

A single-traverse configuration consists of two transducers mounted on opposite sides of the pipe so that the signal they transmit passes through the fluid just once, typically at a 45° angle (see *Figure 1* below). A single-traverse configuration may include more than one path (see *Figure 2* below).

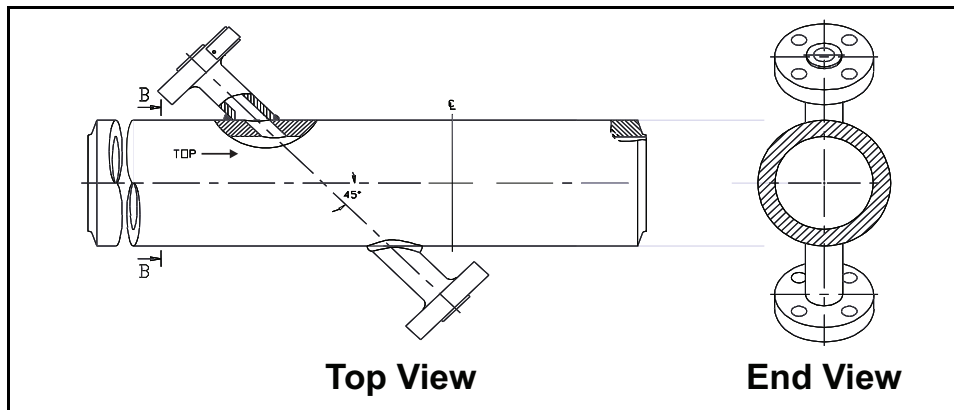

Figure 1: Single-Traverse, 2-Path, Diagonal 45 Meter Body

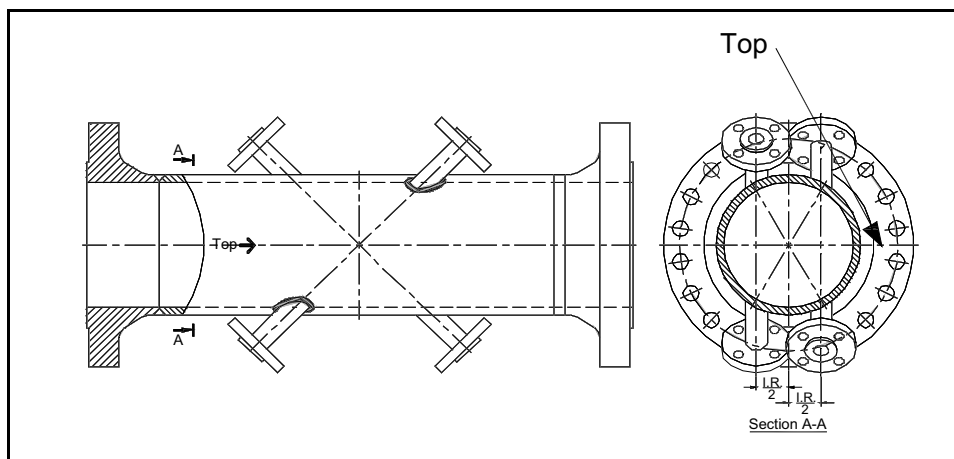

Figure 2: Single-Traverse, 2-Path, Mid-Radius Meter Body

### 1.4.2 Double-Traversal Meter Body

A double-traverse configuration consists of two transducers mounted on the pipe so that the signal traverses the fluid two times before reaching the other transducer (see *Figure 3* below).

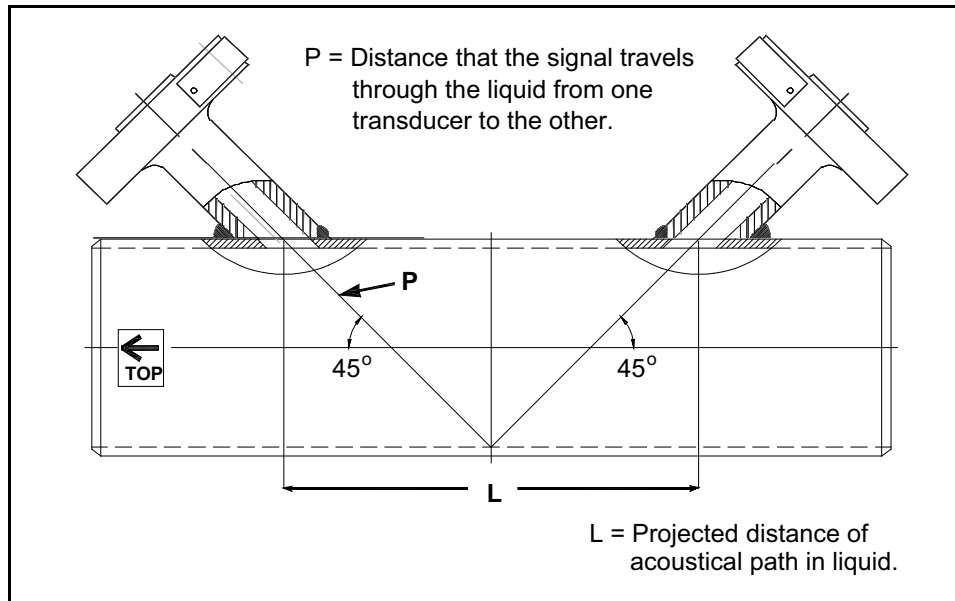

Figure 3: Double-Traversal Meter Body

## 1.5 Handling and Installing a Meter Body

To ensure proper nozzle alignment, Panametrics uses the highest quality welding and machining techniques when manufacturing meter bodies. Since proper alignment of the nozzles is important to making accurate flow measurement, great care must be taken when unpacking and installing the meter body.

### 1.5.1 Unpacking a Meter Body

Upon receipt, you should take great care in unpacking the meter body. Although meter bodies are constructed of steel, improper unpacking or handling can result in damage or affect nozzle alignment. Use the guidelines below for unpacking the meter body:

- Since the nozzles protrude from the pipe, take care when removing packing material and the meter body from its shipping container, so as not to disturb the nozzles.
- After the meter body is removed from its shipping container, never allow the full weight of the meter body to rest on the nozzle or buffer. You should prop up the meter body to prevent it from rolling over, which again, may cause damage or misalignment of nozzles.
- Do not let the meter body hit against other objects or surfaces. Nozzle alignment can be affected if the meter body is dropped onto sand or the ground.
- If the meter body is shipped with the buffers already installed in the nozzles, take care as to not disturb the buffers when unpacking.

### 1.5.2 Installing a Meter Body

Meter bodies can be either flanged or welded into the existing pipeline. Use the following steps to position the meter body into the pipeline (refer to Figure 4 on the next page):



**WARNING!** Before installing the meter body, make sure pipe flushing is completed. For additional information when flushing is necessary, refer to *“Meter Body Requirements When Flushing” on page 7.*

1. Find the tag plate with the words TOP and FLOW DIRECTION marked on it. If the meter body is flanged, two bolt holes should straddle the vertical centerline.

**IMPORTANT:** In general (including cases where the meter body axis is not horizontal), be sure that the installation does not allow gas or sediment to deposit in the transducer ports. Otherwise the sound waves could be attenuated or blocked entirely.

2. Place the meter body in the pipeline so that the FLOW DIRECTION arrow mark is in the direction of flow and the top is appropriately located. (Be sure the transducer ports are in a horizontal plane.)

**IMPORTANT:** If you cannot place the meter body in the required orientation, consult the factory; otherwise operational problems may occur.

3. Do one of the following:
  - Bolt the meter body into place and proceed to the appropriate section that follows to mount the BWT buffers and transducers.
  - Weld the meter body into place in accordance with the requirements described in *Welding Requirements* below. Once welding is completed, proceed to the appropriate section that follows to mount the BWT buffers and transducers.

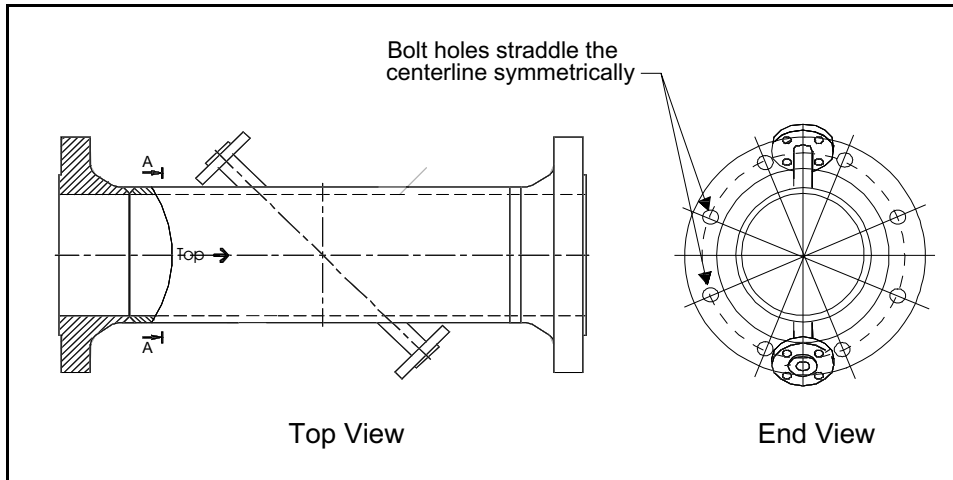

**Figure 4: Top View of a Flanged Meter Body**

## 1.6 Welding Requirements

Prior to welding, do the following:

- Remove power from the flowmeter console and disconnect the cables from the transducers.
- Make sure the inside diameter of the meter body and process pipe are properly aligned. Misalignment can affect measurement accuracy.

## 1.7 Meter Body Requirements When Flushing

Panametrics strongly recommends using a dummy meter body during flushing operations; otherwise, damage may occur for the following reasons:

- Fast moving solid objects in the flowing medium could damage the buffer faces.
- Flushing residue/sediment could clog nozzles.

In the event that a dummy meter body is not available for flushing operations, remove the buffers and plug the holes properly for the temperature and pressure used. Blind flanges are typically used.

Reinstall the buffers and transducers after flushing using the information in this guide.



**CAUTION!** Be sure to use new gaskets when reinstalling buffers. Never reuse gaskets for safety reasons and acoustic performance of the flowmeter.

[no content intended for this page]



## Chapter 2. Standard Installation (FTPA Buffers)

### 2.1 Introduction

The FTPA Buffer is used for both liquid and gas applications. The buffer has a flanged process connection and is typically available in two lengths:

- 2 in. × 6 in. for low process temperature ranges from -150 to 315°C (-270 to 600°F)
- 6 in. × 6 in. for high process temperature ranges from -150 to 600°C (-270 to 1,100°F)

**IMPORTANT:** The buffer ensures that the service temperature of the transducer remains at ambient.

Use the sections that follow to properly install the buffers and transducers.

### 2.2 Identifying and Checking the Components



**CAUTION!** It is critical that you follow the instructions outlined in this document. If you do not, Panametrics cannot ensure the proper operation of your equipment.

Panametrics supplies the parts required for your intended installation. Before you install the FTPA Buffer, check the lists below to make sure you have all of the needed components. Refer to *Figure 5 on page 10* and *Figure 6 on page 10* to help you identify each component.

**Note:** The list below is for a **one-path** installation.

- 2 FTPA buffers
- 2 BWT1 transducers
- 2 Kamprofile gaskets

**IMPORTANT:** Kamprofile gaskets must be used for two reasons: they ensure a leak tight seal and they provide necessary acoustic isolation.

- 2 Mating lap-joint flanges
- 2 Junction boxes
- Preamplifiers - required for gas flow applications (may be mounted in transducer junction box)
- 3M epoxy or equivalent (for permanent bond) (*not shown in photo*)
- Required studs, nuts and washers (*not shown in photo*)
- 10 ft (3 m) Coaxial cable with BNC connectors (*not shown in photo*)
- Additional preamplifier to electronics cable (required for gas flow applications) (*not shown in photo*)

You will need to supply the following additional items:

- Copperslip (SS316), Molykote grease P47 (CS) or equivalent anti-seizing compound
- Adjustable torque wrench with 15-148 ft-lb range (20-200 N-m) with socket drive
- Standard and deep sockets
- Adjustable wrench (12 in. long or equivalent)
- Steel wool
- Calipers

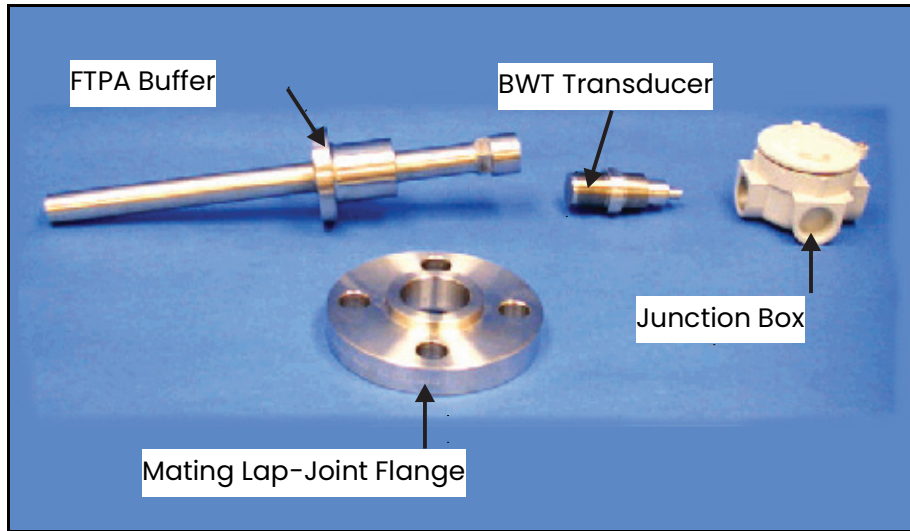

Figure 5: Components for FTPA Buffer

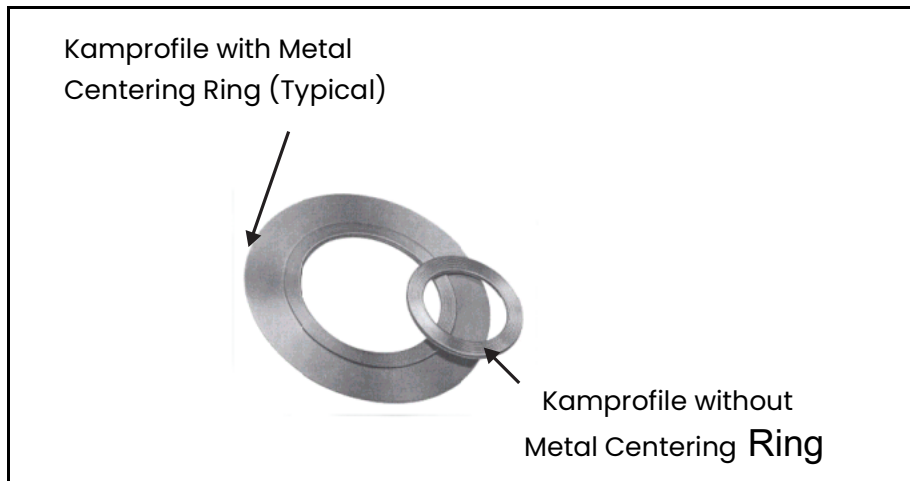
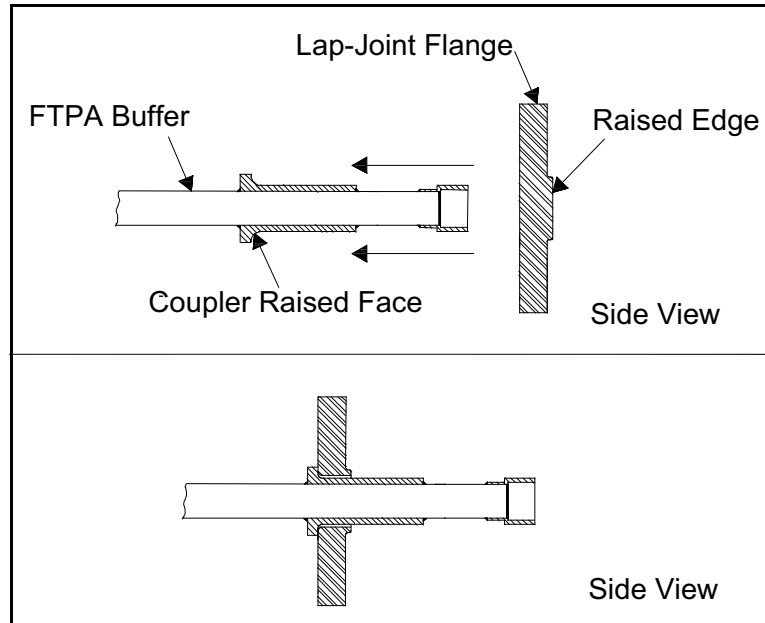

Figure 6: Gaskets

## 2.3 Assembling the Standard FTPA Buffer

**Note:** If the BWT system is shipped with the buffers already installed in the nozzles, proceed to "Installing the BWT Transducer" on page 16.

1. Slide the lap-joint flange over the threaded end of the FTPA Buffer. Make sure you orient the flange as shown below.



2. Check the raised face of the spool nozzle flange to make sure it is free from paint, rust, dirt, corrosion, and damage. If necessary, clean the raised faces with steel wool. In addition, clean the buffer flange if you are reusing an existing buffer.
3. Inspect the gaskets supplied by Panametrics. They must not be used, warped, pitted or scratched.
4. Place one gasket on the end of the buffer assembly.

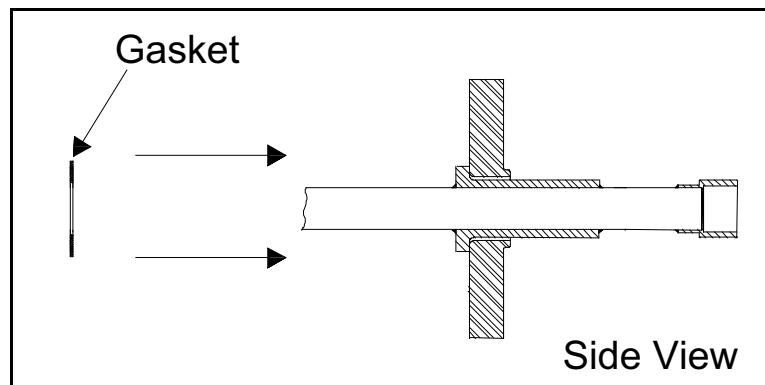

## 2.4 Inserting the Standard FTPA Buffer

1. Inspect the pipe nozzle. Make sure it is free from dirt and rust. Use steel wool to clean the pipe nozzle face and inside surfaces if necessary.
2. Insert the buffer assembly into the nozzle.

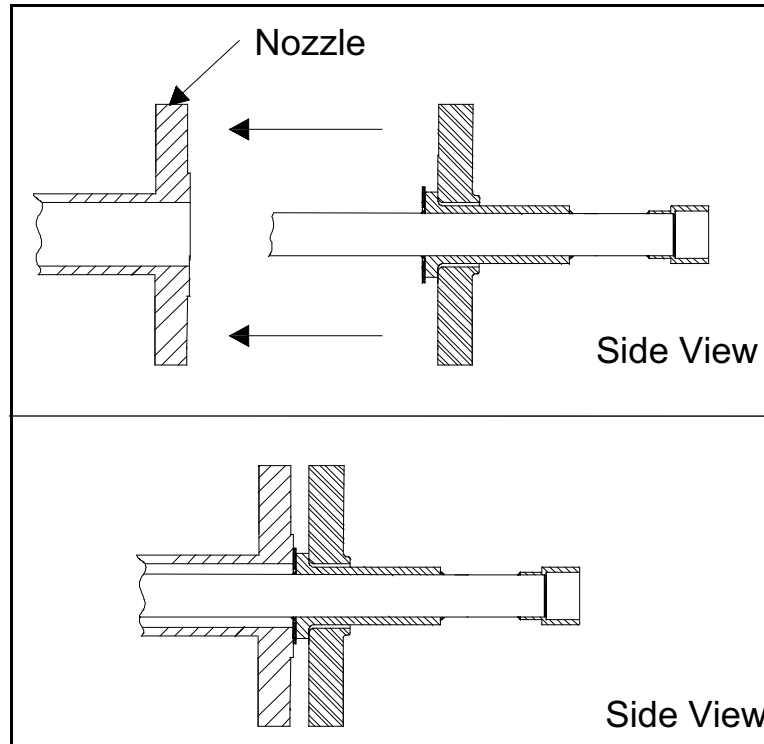

3. Apply Copperslip, Molykote or equivalent anti-seize compound on the first several threads at both ends of each stud.
4. Insert one of the studs through the flanges. Make sure the stamped quality rating on the stud (e.g. B7) is facing away from the meter body. Hand-tighten a washer and nut on each end of the stud. Make sure you leave an equal number of threads exposed on each end of the stud.

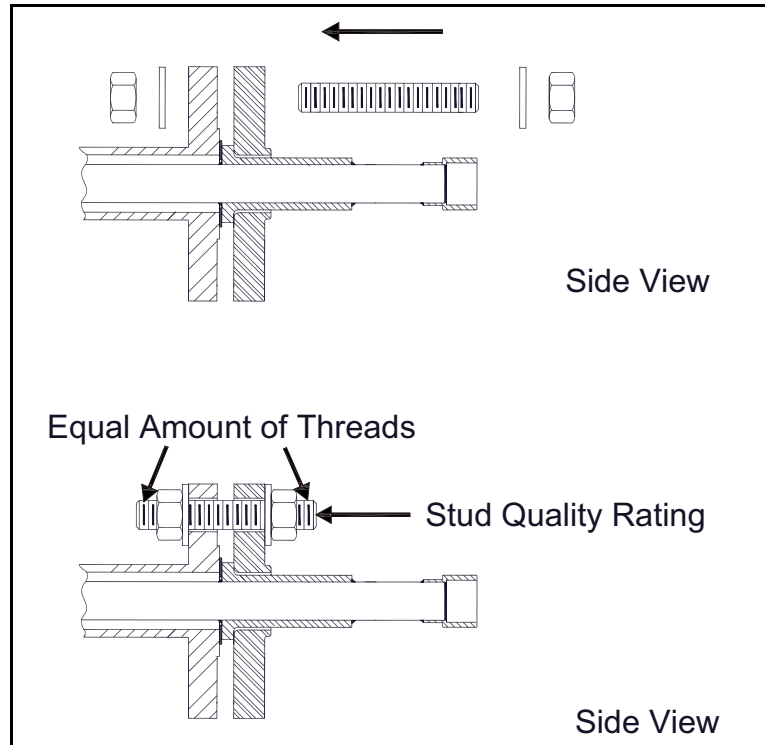

5. Install the remaining studs in the order shown below, but **do not** fully tighten the nuts yet.

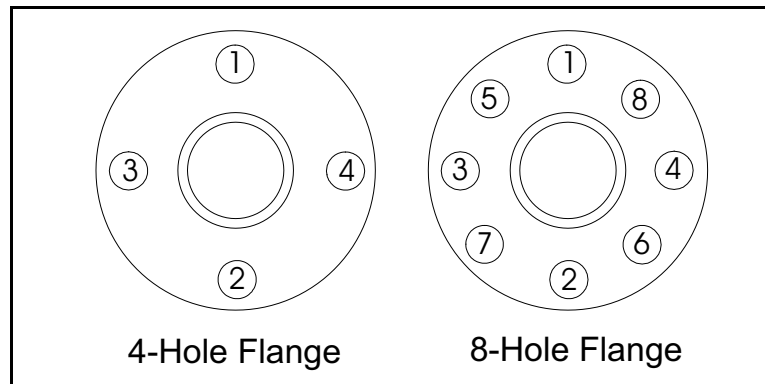

6. Center the buffer in the middle of the lap joint flange. Inspect 360° around the flanges to ensure equal spacing, by sliding your fingers around the gap between the buffer flange and the nozzle flange.
7. Then, align the flanges as shown below.

**IMPORTANT:** Make sure the gasket is in the center of the flanges.

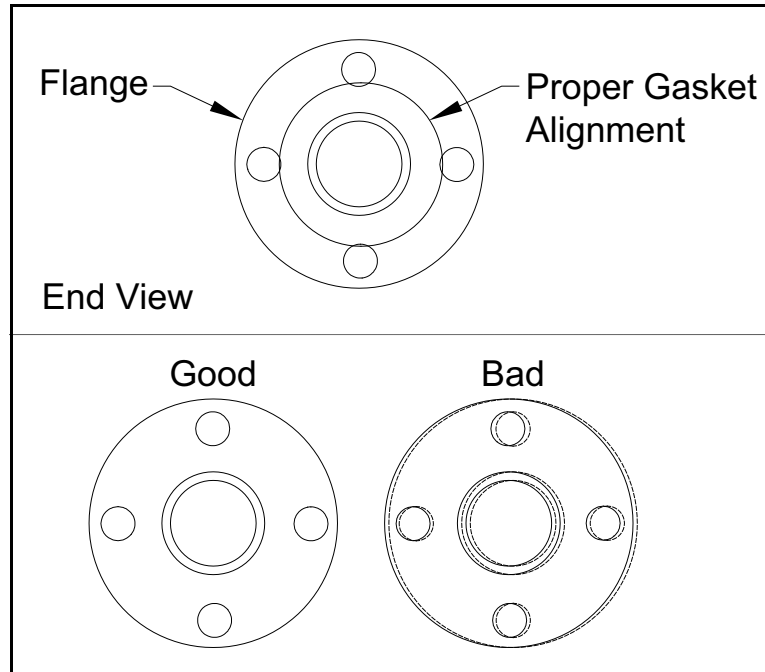

8. Tighten the nuts on the studs further by hand to maintain the centering. Visually verify that the buffer is centered in the lap joint flange. If necessary, adjust the buffer by hand until it is centered.

It is important to torque the studs properly for a good seal. However, do not over-torque them or you will cause an acoustic short or change the transducer alignment.

Tighten and torque the studs in increments, as described below.

1. Check the flange and buffer alignment again. Make sure the flanges are consistently parallel to each other.

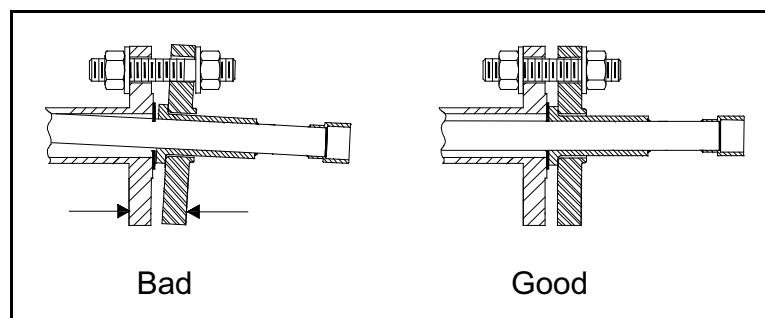

2. Using an adjustable wrench, turn the first nut 1/8 turn.

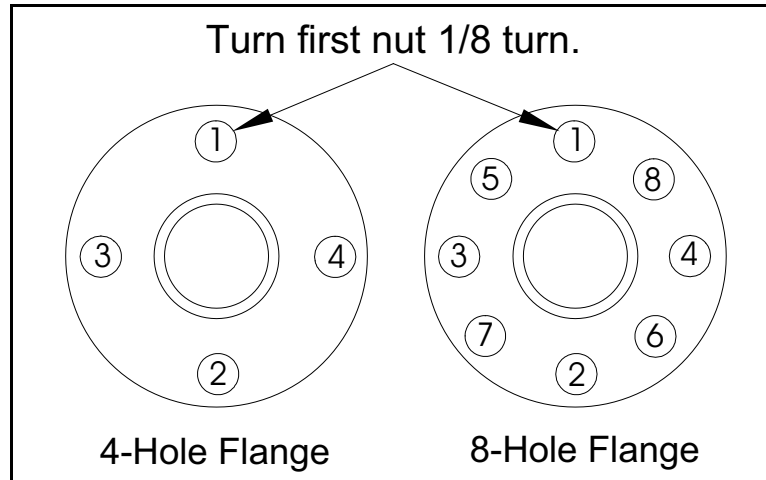

- Turn the nut on the second stud 1/8 turn. The second stud should be diametrically opposite the first stud. Proceed to tighten the remaining studs in the order shown below, or in a similar manner.

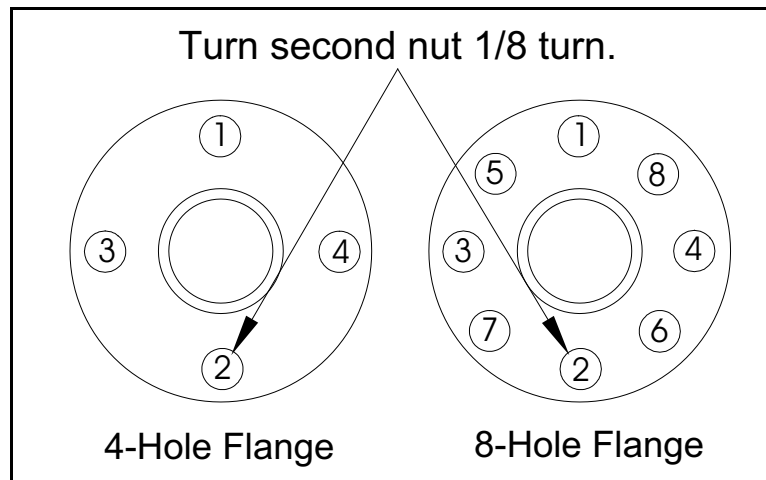

- Turn each nut an additional 1/8 turn. Be sure to **TURN THE NUTS IN THE SEQUENCE SHOWN**.
- Use *Table 1* below to determine the appropriate final torque for your studs.

**Table 1: Final Torques**

Flange Size and Rating	Stud Rating with 4 Studs/Flange	Stud Diameter (in.) x Length (in.)	Torque in ft-lb (N-m)
316 Stainless Steel			
1 1/2" ANSI 150#	B8M,C,1	1/2" x 3 1/4"	56 (76)
1 1/2" ANSI 300#	B8M,C,1	3/4" x 4 3/4"	82 (111)
1 1/2" ANSI 600#	B8M,C,1	3/4" x 4 3/4"	82 (111)
1 1/2" ANSI 900#	B8M,C,1	1" x 6"	107 (145)
1 1/2" ANSI 1500#	B8M,C,1	1" x 6"	107 (145)
Carbon Steel			
1 1/2" ANSI 150#	B7	1/2" x 3 1/4"	56 (76)
1 1/2" ANSI 300#	B7	3/4" x 4 3/4"	82 (111)
1 1/2" ANSI 600#	B7	3/4" x 4 3/4"	82 (111)

**Table 1: Final Torques**

Flange Size and Rating	Stud Rating with 4 Studs/Flange	Stud Diameter (in.) x Length (in.)	Torque in ft-lb (N-m)
1 1/2" ANSI 900#	B7	1" x 6"	107 (145)
1 1/2" ANSI 1500#	B7	1" x 6"	107 (145)

6. You must torque the flange studs in small increments. Divide the appropriate torque by 10 to determine the number of steps. For example, if the required final torque is 90 ft-lb, the remaining steps would be 20, 30, 40, 50, 60, 70, 80 and 90 ft-lb.
7. Set the torque wrench for the first setting and torque the studs in sequence. Turn each stud a maximum of a 1/8 turn at a time.
8. Repeat Step 7 for each of the incremental torque settings.
9. Check the flange alignment again to ensure that the flanges are parallel to each other. Measure the spacing between the flanges with the caliper on at least four equally-spaced points. The maximum tolerance is  $\pm 0.2$  mm difference between the four measured points. If you cannot achieve a tolerance of  $\pm 0.2$  mm or less, replace the gasket with a new gasket, and repeat this entire procedure.

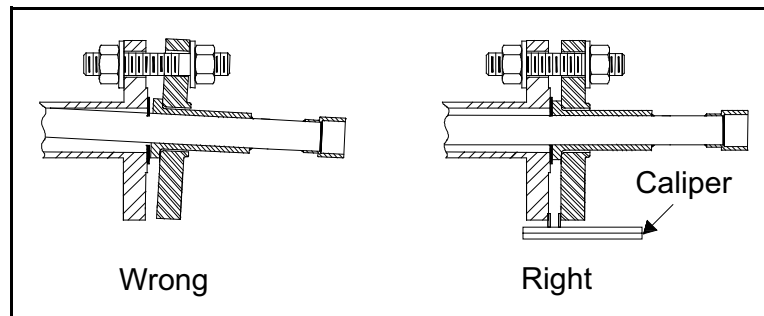

10. Repeat the above steps for the remaining flanges.

## 2.5 Installing the BWT Transducer

Installing the BWT transducers into the FTPA Buffer requires the following three steps:

- Installing and orienting the junction box (see *page 17*)
- Inserting the BWT transducers (see *page 18*)
- Verifying the installation (see *page 19*)



### 2.5.1 Installing and Orienting the Junction Box

Before placing the BWT transducer into the FTPA buffer permanently, you must make sure the junction box will be properly oriented after it is installed.

1. Screw the transducer into the junction box as shown below.

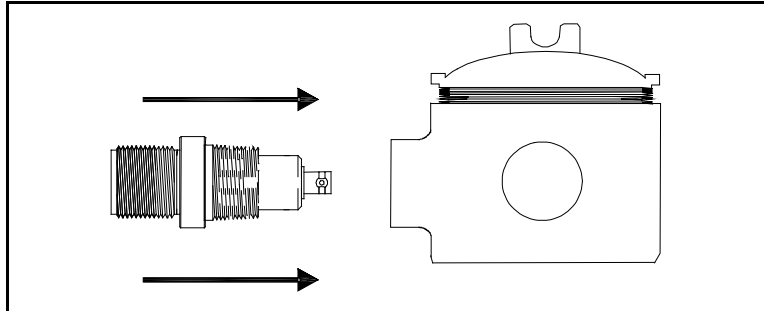

2. Screw the transducer/junction box assembly into the FTPA Buffer.

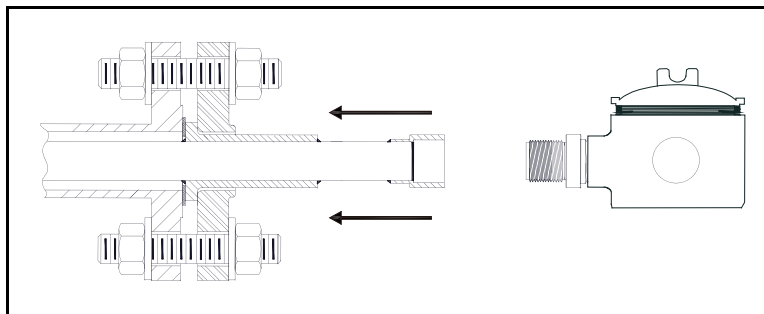

3. Check the junction box orientation. The junction box cover should be at a downward angle so that any liquid can drain out of the box. If necessary, adjust the junction box until the cover is angled downward.



4. Remove the transducer/junction box assembly.
5. Repeat the above steps for the other transducer.

## 2.5.2 Inserting the BWT Transducer

Please read the following steps completely before beginning the installation of the BWT transducer.

**IMPORTANT:** After you install the BWT transducers, you must allow the epoxy to cure for eight hours.

**Note:** *In gas applications, the typical minimum pressure should be 5 barg (75 psig) for the transducers to receive any signal. A pressure higher than this minimum should result in a better signal-to-noise ratio.*

1. As shown below, place a small droplet (2 mm in diameter) of 3M Epoxy or equivalent on the center of the transducer face (the picture below shows the transducer without the junction box).



2. Screw the transducer/junction box into the fitting at the end of the FTPA Buffer. When you begin to feel some resistance, stop turning the transducer and wait 5 seconds to give the couplant a chance to spread out.

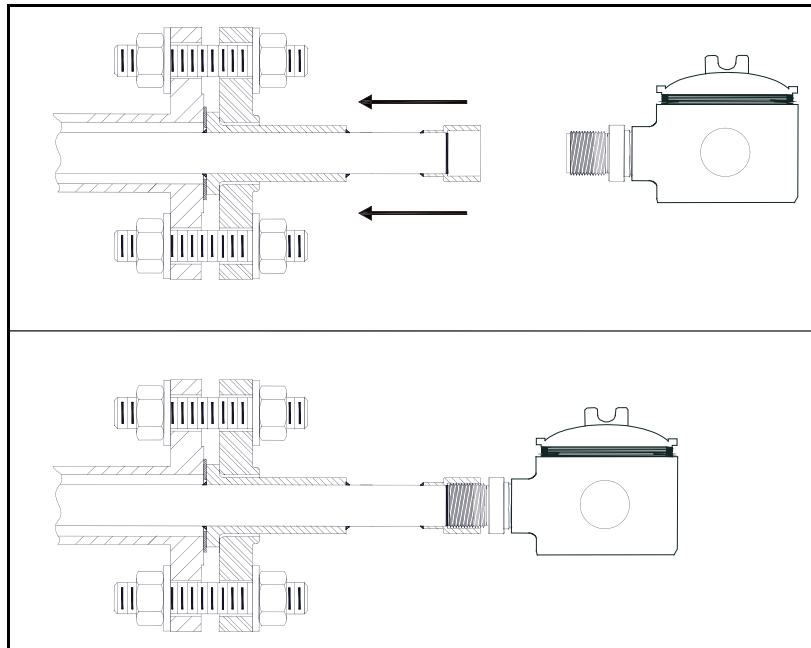

**IMPORTANT:** In the next step, **DO NOT** overtighten the transducer.

3. Torque the transducer to a maximum of 15-18 ft-lb (20- 25 N-m).
4. Verify that the junction box is properly oriented as discussed in the previous section (see *page 17*).
5. To connect the transducer electrical cables, see the *Startup* or *User's Manual* that was supplied with your flowmeter.



**CAUTION!** Do not place insulation on or around the transducer or junction box. The transducer and junction box act as a heat sink that protects the transducer from high and low temperatures.

6. After you install the FTPA Buffers and transducers, you must allow the epoxy to cure for eight hours. However, while the epoxy cures, you should verify that the transducer and buffer are working properly (see the next section).



**CAUTION!** While the epoxy cures, do not remove, re-torque or adjust the transducer or you will crack the epoxy.

7. Repeat steps 1–6 to install the other transducer.

### 2.5.3 Verifying the Installation

To verify that the installation is working properly, complete the following steps:

1. Power up the electronics.
2. Refer to *Displaying Diagnostics* in the flowmeter *Service or User's Manual* to display the upstream and downstream transducer signal strength.
3. Record this data in the *Service Record* in the appendix provided for this purpose in the flowmeter *Service or User's Manual*.
4. Verify that the signal strength diagnostics readings are the same or better after 8 hours of operation.

This completes the installation of the FTPA buffers and transducers. Refer to the flowmeter *Startup Guide or User's Manual* for instructions on obtaining flow rate measurements.

[no content intended for this page]

## Chapter 3. Acoustic Isolation Installation (FIPA Buffers)

### 3.1 Introduction

The FIPA Buffer is used for gas applications at lower pressures. This buffer has a flanged isolation section that reduces acoustic short circuits. The buffer also has a flanged process connection and is typically available in two lengths:

- 2 in. × 6 in. for low temperature ranges from -150 to 315°C (-270 to 600°F)
- 6 in. × 6 in. for high temperature ranges from -150 to 600°C (-270 to 1,100°F)

Follow the instructions in this chapter to properly install the buffers and transducers.

### 3.2 Identifying and Checking the Components



**CAUTION!** It is critical that you follow the instructions presented in this document. If you do not, Panametrics cannot ensure the proper operation of your equipment.

Panametrics supplies the parts required for your installation. Before you begin, check the lists below to make sure you have all of the needed components. Refer to *Figure 7 on page 22* and *Figure 8 on page 22* to help you identify each component.

**Note:** The list below is for a **one-path** installation.

- Acoustic Isolation FIPA Buffers - *fully assembled*
- 2 BWT1 transducers
- 2 Kamprofile gaskets

**IMPORTANT:** Kamprofile gaskets must be used for two reasons: they ensure a leak tight seal and they provide necessary acoustic isolation.

- 2 Junction boxes
- Preamplifiers - required for gas flow applications (may be mounted in transducer junction box)
- 3M epoxy or equivalent for permanent bond (*not shown in photo*)
- Required studs, nuts and washers (*not shown in photo*)
- 10 ft (3 m) coaxial cable with BNC connectors (*not shown in photo*)
- Additional preamplifier to electronics cable (required for gas flow applications) (*not shown in photo*)

You will need to supply the following additional items:

- Copperslip (SS316), Molykote grease P47 (CS) or equivalent anti-seizing compound
- Adjustable torque wrench with 15-148 ft-lb range (20-200 N-m) with socket drive
- Standard and deep sockets
- Adjustable wrench (12 in. long or equivalent)
- Steel wool
- Calipers
- Tape measure

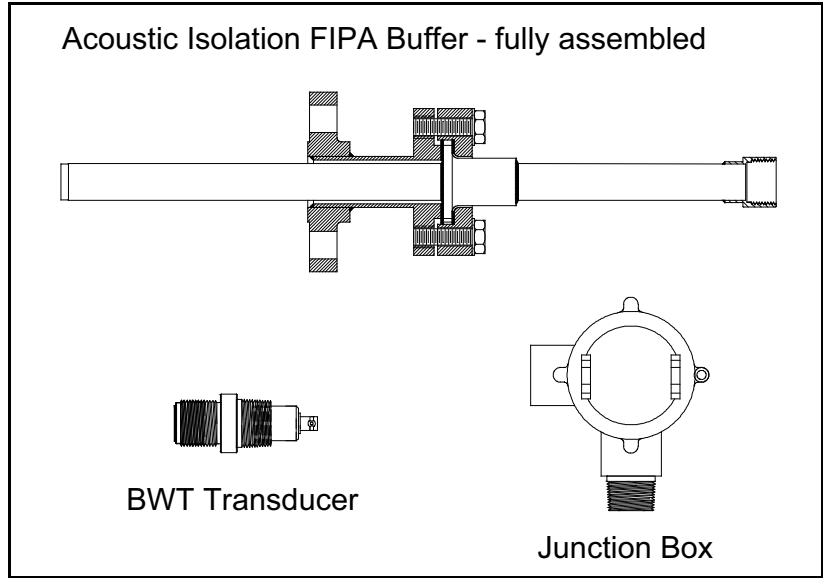

Figure 7: Components for Acoustic Isolation FIPA Buffer

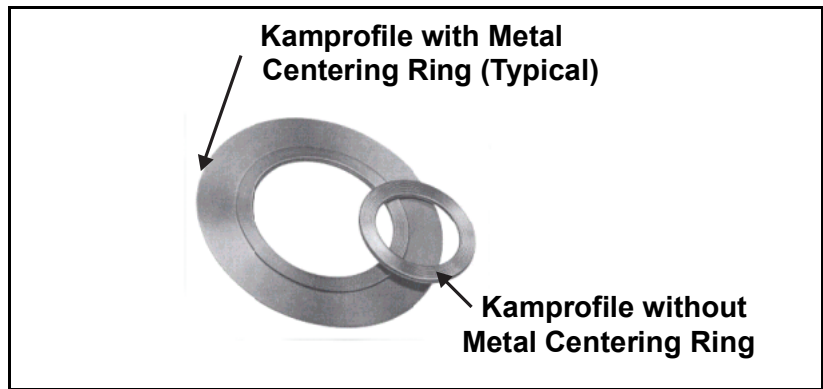

Figure 8: Gaskets

### 3.3 Inserting the Acoustic Isolation FIPA Buffer

When you receive the *Acoustic Isolation FIPA Buffer* it will be fully assembled. Follow the instructions below to properly install the buffer.

**Note:** *If the BWT system is shipped with the buffers already installed in the nozzles, proceed to "Installing the BWT Transducer" on page 30.*

1. Check the raised face of the spool nozzle flange to make sure it is free from paint, rust, dirt, corrosion, and damage. If necessary, clean the raised faces with steel wool. In addition, clean the buffer flange if you are reusing an existing buffer.

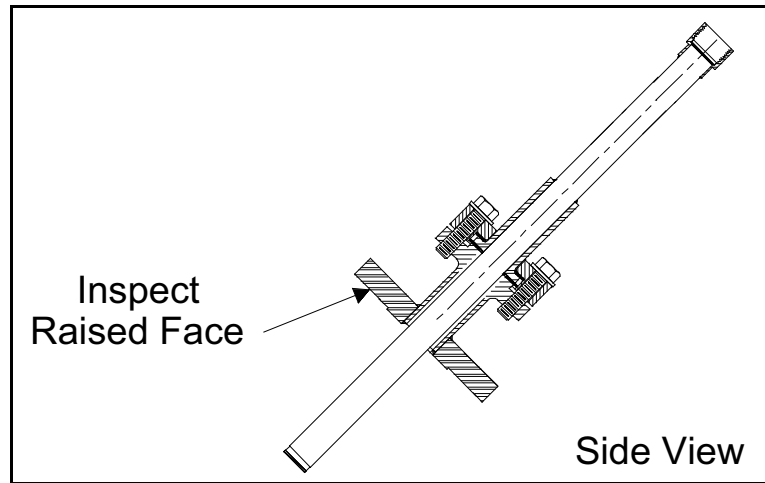

2. Inspect the gaskets supplied by Panametrics. They must not be used, warped, pitted or scratched.
3. Place one gasket on the end of the buffer.

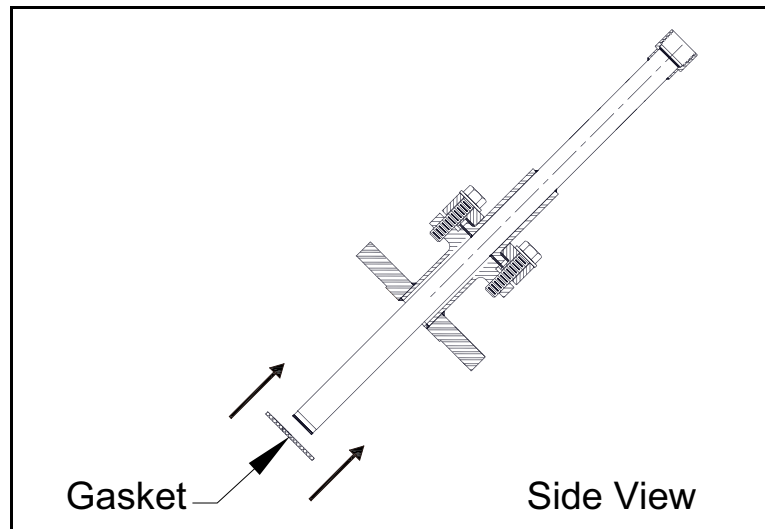

4. Inspect the pipe nozzle to make sure it is free from dirt and rust. Use the steel wool to clean the pipe nozzle face and the inside surfaces if necessary.

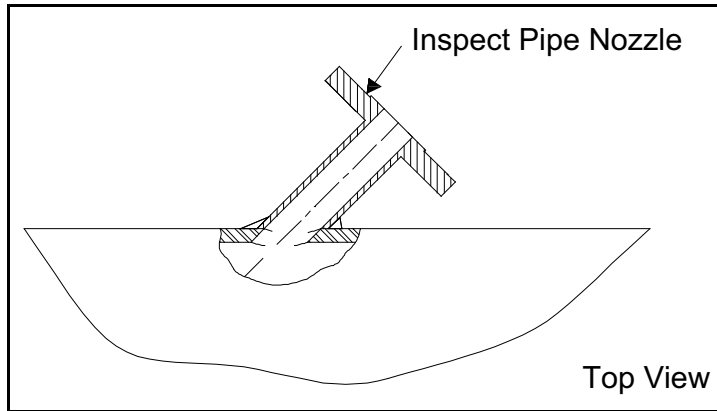

5. Insert the buffer/gasket assembly into the nozzle.

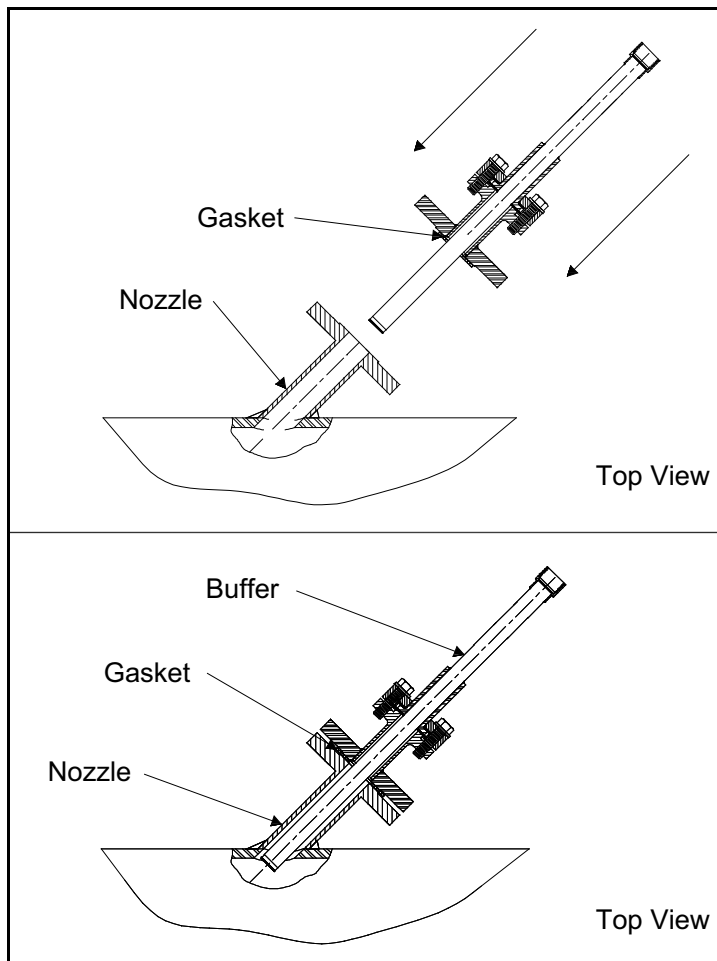

6. Apply Copperslip, Molykote or equivalent anti-seize compound on the first several threads at both ends of each stud.
7. Insert one of the studs through the flanges. Make sure the stamped quality rating on the stud (e.g., B7) is facing away from the meter body. Hand-tighten a washer and nut on each end of the stud. Make sure you leave an equal number of threads exposed on each end of the stud.





**CAUTION!** Do not adjust the studs on the FIPA isolation flange. The isolation flange is already set to specification determined at the factory.

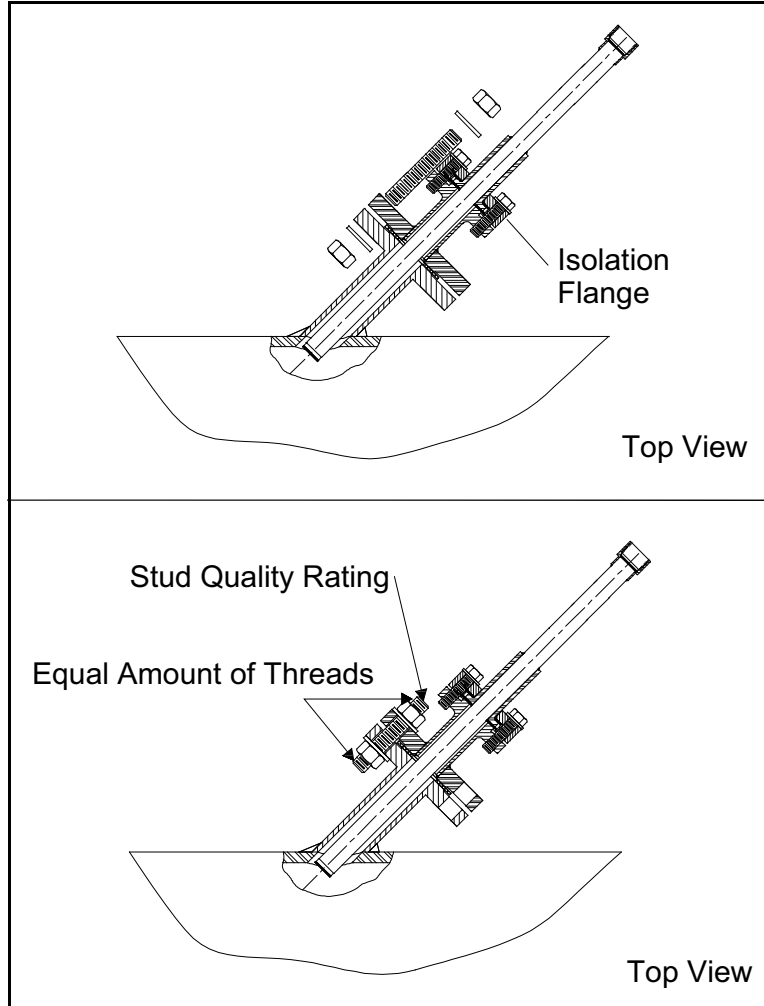

8. Install the remaining studs in the order shown below, but **do not** fully tighten the nuts yet.

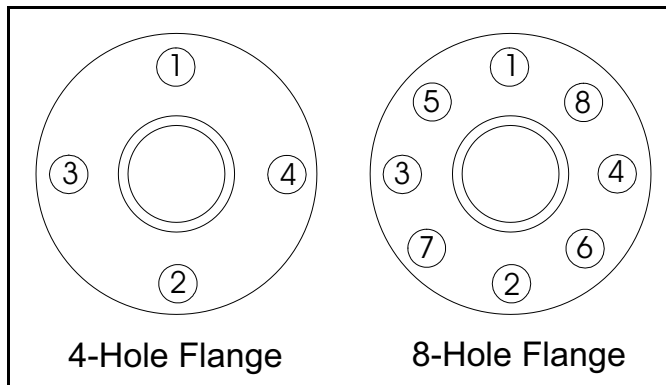

9. Inspect 360° around the flanges to ensure equal spacing, by sliding your fingers around the gap between the buffer flange and the nozzle flange.
10. Then align the flanges as shown below.

**IMPORTANT:** Make sure the gasket is in the center of the flanges.

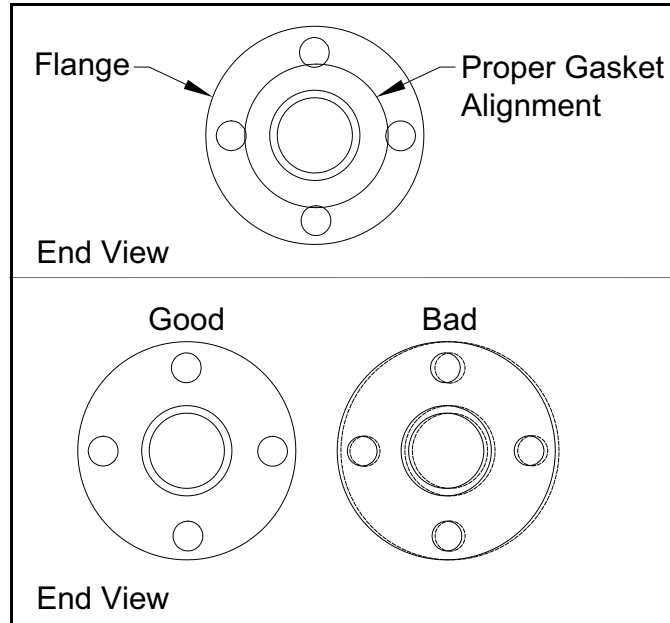

11. Tighten the nuts on the studs further by hand to maintain the centering. Visually verify that the buffer is centered in the lap joint flange. If necessary, adjust the buffer by hand until it is centered.

### 3.4 Torquing the Studs

It is important to torque the studs properly for a good seal. However, do not over-torque them or you will cause an acoustic short or change the transducer alignment.

Tighten and torque the studs in increments, as described below.

1. Check the flange and buffer alignment again. Make sure the flanges are consistently parallel to each other.

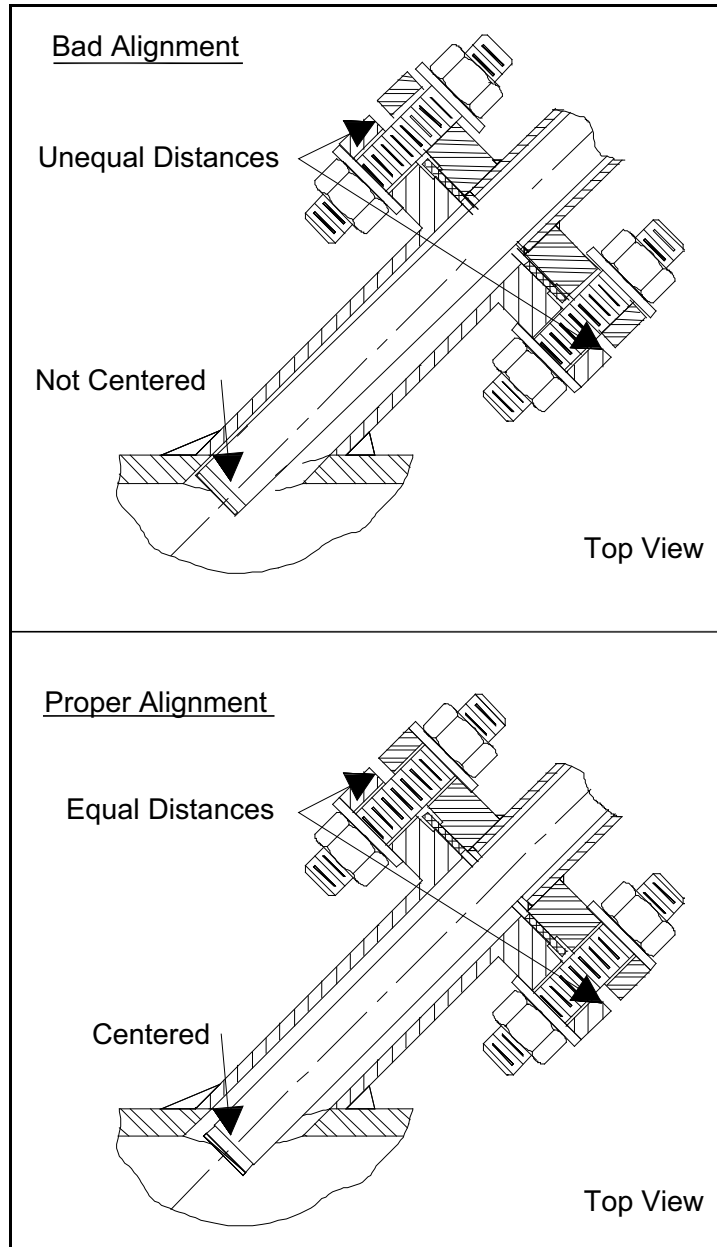

2. Using an adjustable wrench, turn the first nut 1/8 turn.

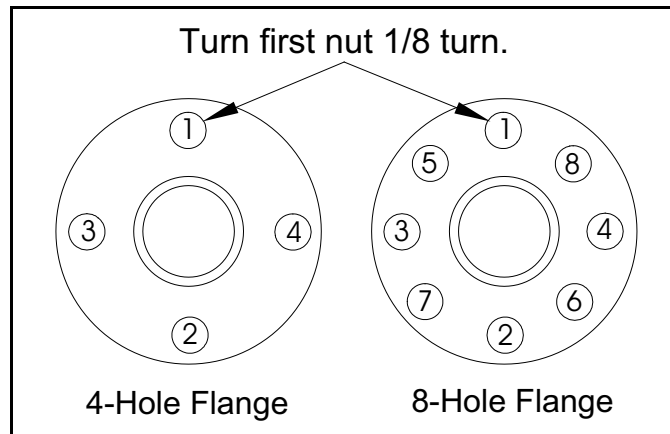

3. Turn the nut on the second stud 1/8 turn. The second stud should be diametrically opposite the first stud. Proceed to tighten the remaining studs in the order shown below, or in a similar manner.

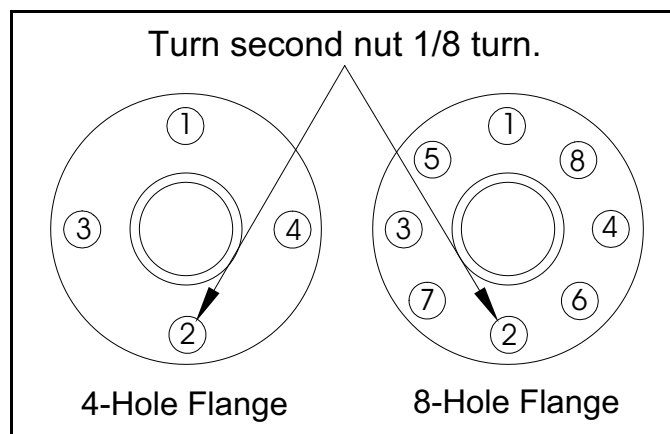

4. Turn each nut an additional 1/8 turn. Be sure to **TURN THE NUTS IN THE SEQUENCE SHOWN**.
5. Use *Table 2* below to determine the appropriate final torque for your studs.

**Table 2:**

Flange Size and Rating	Stud Rating with 4 Studs/Flange	Stud Diameter (in.) x Length (in.)	Torque in ft-lb (N-m)
316 Stainless Steel			
1 1/2" ANSI 150#	B8M,C,1	1/2" x 3 1/4"	56 (76)
1 1/2" ANSI 300#	B8M,C,1	3/4" x 4 3/4"	82 (111)
1 1/2" ANSI 600#	B8M,C,1	3/4" x 4 3/4"	82 (111)
1 1/2" ANSI 900#	B8M,C,1	1" x 6"	107 (145)
1 1/2" ANSI 1500#	B8M,C,1	1" x 6"	107 (145)
carbon steel			
1 1/2" ANSI 150#	B7	1/2" x 3 1/4"	56 (76)
1 1/2" ANSI 300#	B7	3/4" x 4 3/4"	82 (111)
1 1/2" ANSI 600#	B7	3/4" x 4 3/4"	82 (111)
1 1/2" ANSI 900#	B7	1" x 6"	107 (145)
1 1/2" ANSI 1500#	B7	1" x 6"	107 (145)

6. You must torque the flange studs in small increments. Divide the appropriate torque by 10 to determine the number of steps. For example, if the required final torque is 90 ft-lb, the remaining steps would be 20, 30, 40, 50, 60, 70, 80 and 90 ft-lb.
7. Set the torque wrench for the first setting and torque the studs in sequence. Turn each stud a maximum of a 1/8 turn at a time.
8. Repeat Step 7 for each of the incremental torque settings.
9. Check the flange alignment again to ensure that the flanges are parallel to each other. Measure the spacing between the flanges with the caliper on at least four equally-spaced points. The maximum tolerance is  $\pm 0.2$  mm difference between the four measured points. If you cannot achieve a tolerance of  $\pm 0.2$  mm or less, replace the gasket with a new gasket, and repeat this entire procedure.

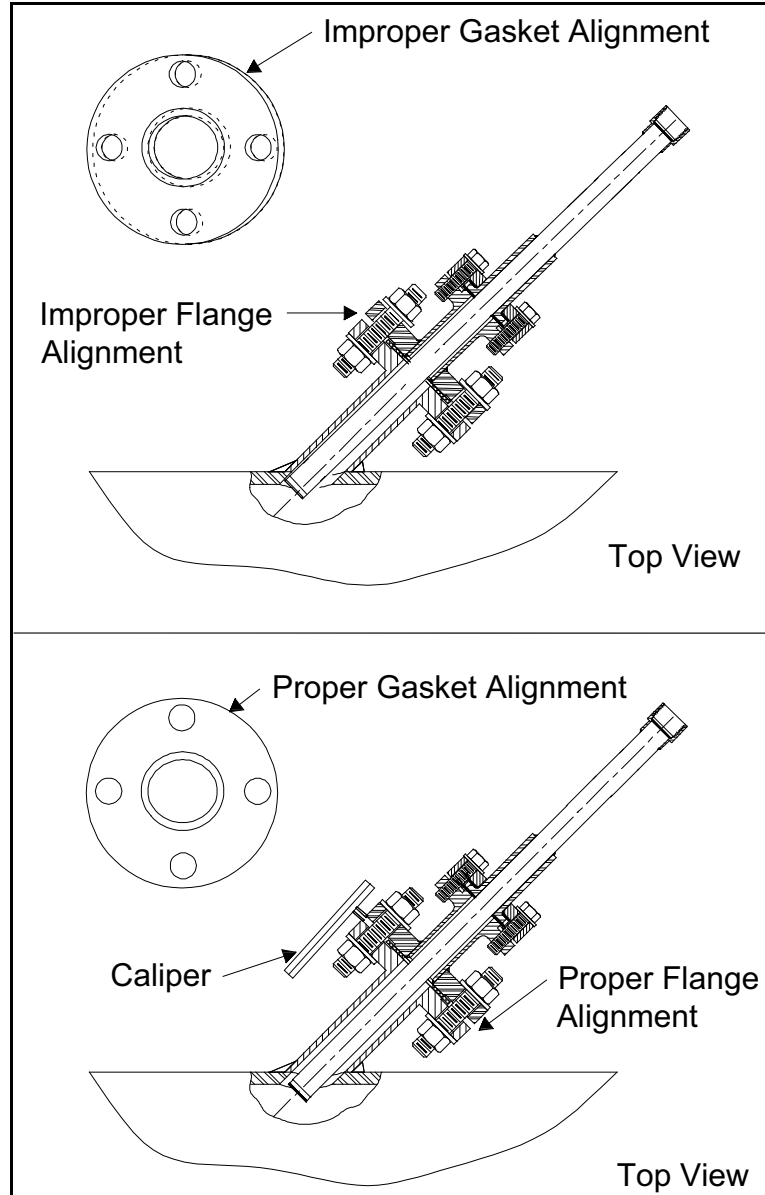

10. Repeat the above steps for the remaining flanges.

### 3.5 Installing the BWT Transducer

Installing the BWT transducers into the FIPA Buffer requires the following three steps:

- Installing and orienting the junction box (see *page 30*)
- Inserting the BWT transducers (see *page 31*)
- Verifying the installation (see *page 33*)

#### 3.5.1 Installing and Orienting the Junction Box

Before placing the BWT transducer into the FIPA buffer permanently, you must make sure the junction box will be properly oriented after it is installed.

1. Screw the transducer into the junction box as shown below.

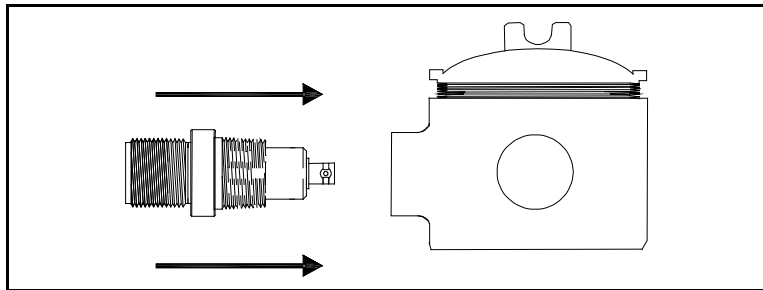

2. Screw the transducer/junction box assembly into the FIPA Buffer.

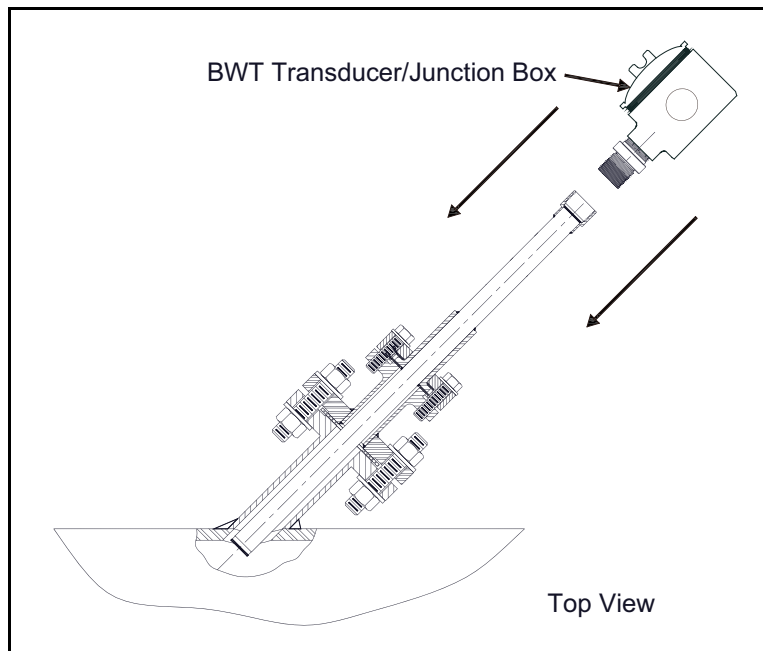

3. Check the junction box orientation. The junction box cover should be at a downward angle so that any liquid can drain out of the box. If necessary, adjust the junction box until the cover is angled downward.

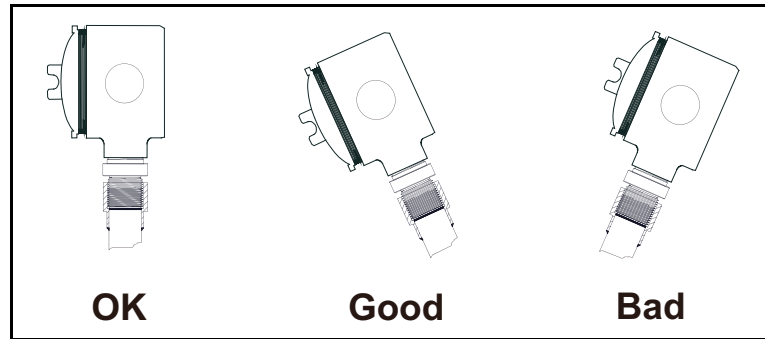

4. Remove the transducer/junction box assembly.
5. Repeat the above steps for the other transducer.

### 3.5.2 Inserting the BWT Transducer

Please read the following steps completely before beginning the installation of the BWT transducer.

**IMPORTANT:** After you install the BWT transducers, you must allow the epoxy to cure for eight hours.

**Note:** *In gas applications, the typical minimum pressure should be 5 barg (75 psig) for the transducers to receive any signal. A pressure higher than this minimum should result in a better signal-to-noise ratio.*

1. As shown below, place a small droplet (2 mm in diameter) of 3M Epoxy or equivalent on the center of the transducer face (the picture below shows the transducer without the junction box).



2. Screw the transducer/junction box into the fitting at the end of the FIPA Buffer. When you begin to feel some resistance, stop turning the transducer and wait 5 seconds to give the couplant a chance to spread out.

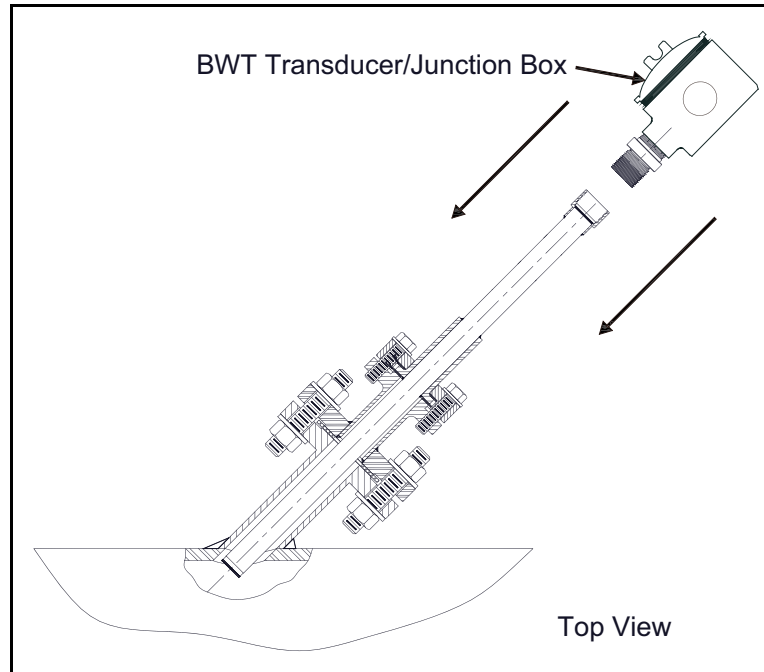

**IMPORTANT:** In the next step, **DO NOT** overtighten the transducer.

3. Torque the transducer to a maximum of 15-18 ft-lb (20- 25 N-m).
4. Verify that the junction box is properly oriented as discussed in the previous section (see *page 30*).
5. To connect the transducer electrical cables, see the *Startup* or *User's Manual* that was supplied with your flowmeter.



**CAUTION!** Do not place insulation on or around the transducer or junction box. The transducer and junction box act as a heat sink that protects the transducer from high and low temperatures.

6. After you install the FIPA Buffers and transducers, you must allow the epoxy to cure for 8 hours. However, while the epoxy cures, you should verify that the transducer and buffer are working properly (see the next section) below.



**CAUTION!** While the epoxy cures, do not remove, re-torque or adjust the transducer or you will crack the epoxy.

7. Repeat steps 1-6 to install the other transducer.



### 3.5.3 Verifying the Installation

To verify that the installation is working properly, complete the following steps:

1. Power up the electronics.
2. Refer to *Displaying Diagnostics* in the flowmeter *Service or User's Manual* to display the upstream and downstream transducer signal strength.
3. Record this data in the *Service Record* in the appendix provided for this purpose in the flowmeter *Service or User's Manual*.
4. Verify that the signal strength diagnostics readings are the same or better after 8 hours of operation.

This completes the installation of the FTPA buffers and transducers. Refer to the flowmeter *Startup or User's Manual* for instructions on obtaining flow rate measurements.

### 3.6 Installing Additional Acoustic Isolation

If your application requires additional acoustic isolation, obtain the following items to perform the procedure:

- 1 to 3 ring collets (for 4 in. pipes or larger)
- Allen wrench

After you have obtained the above items, complete the following steps:

1. If you are using more than one collet, refer to the figure below and adjust the spacing rods on each pipe riser fixture to 1 in. (25 mm). When adjusting the rods, make sure you position the collets on the buffer so that they face each other.

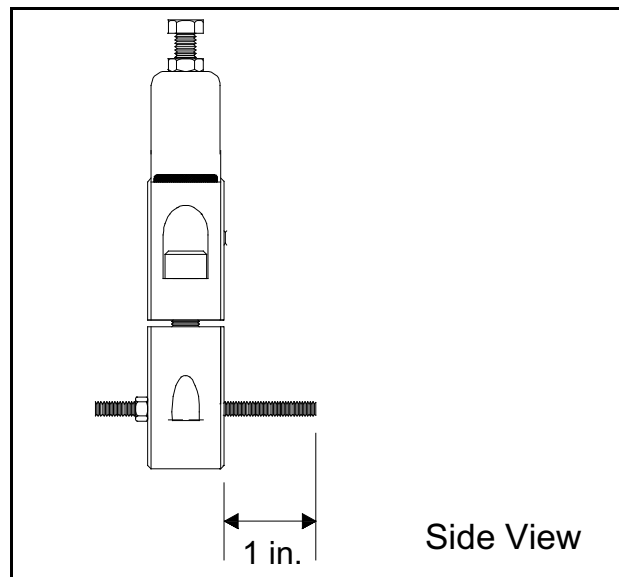

2. Use an Allen wrench to separate the two halves of the collet so that it can be placed on the buffer. Repeat the procedure for the other collets.

**IMPORTANT:** Be sure not to mix pieces from different fixtures.

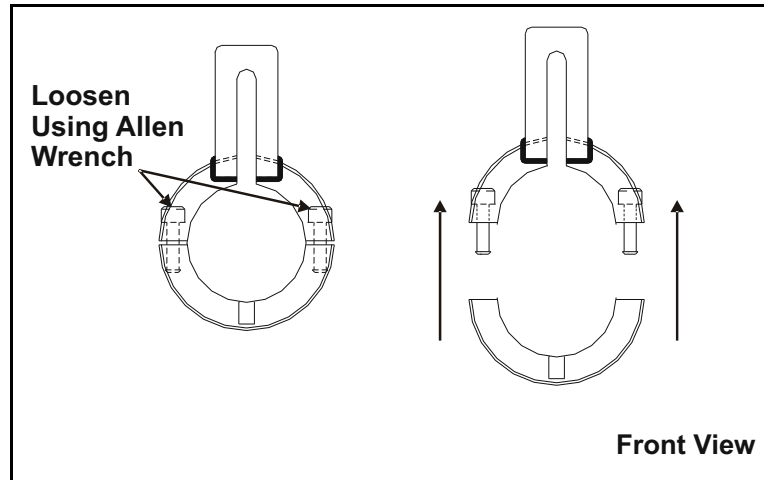

3. Place the collets on the buffer as shown below.

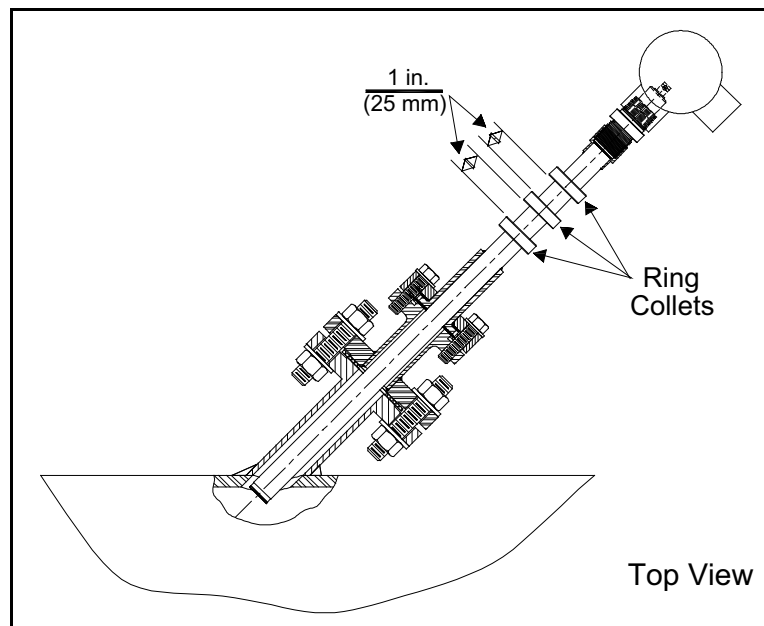

4. Repeat the above steps for the other transducer.

This completes the installation of the FIPA buffers and transducers. Refer to the flowmeter *Startup Guide* or *User's Manual* for instructions on obtaining flow rate measurements.

## Chapter 4. Non-Flanged Installation (FSPA/FWPA Buffers)

### 4.1 Introduction

The non-flanged **FSPA** and **FWPA** buffers (see *Figure 9* below) are available in either stainless steel or titanium. The **FSPA** is a threaded buffer that is screwed into the pipe coupling or nozzle, and the **FWPA** is a socket-weld buffer that is welded into the pipe coupling. Both types of buffers enable you to install and remove transducers easily without interrupting the process or emptying the pipe.

Installing the BWT transducers into an **FSPA** or **FWPA** buffer requires three steps:

- Installing the **FSPA** or **FWPA** buffer (see *page 36*)
- Installing and orienting the transducer junction box (see *page 37*)

**Note:** For gas flow applications, a preamplifier is required. In such applications, the preamplifier may be mounted in the transducer junction box.

- Inserting the BWT transducers (see *page 38*)
- Verifying the Installation (see *page 39*)

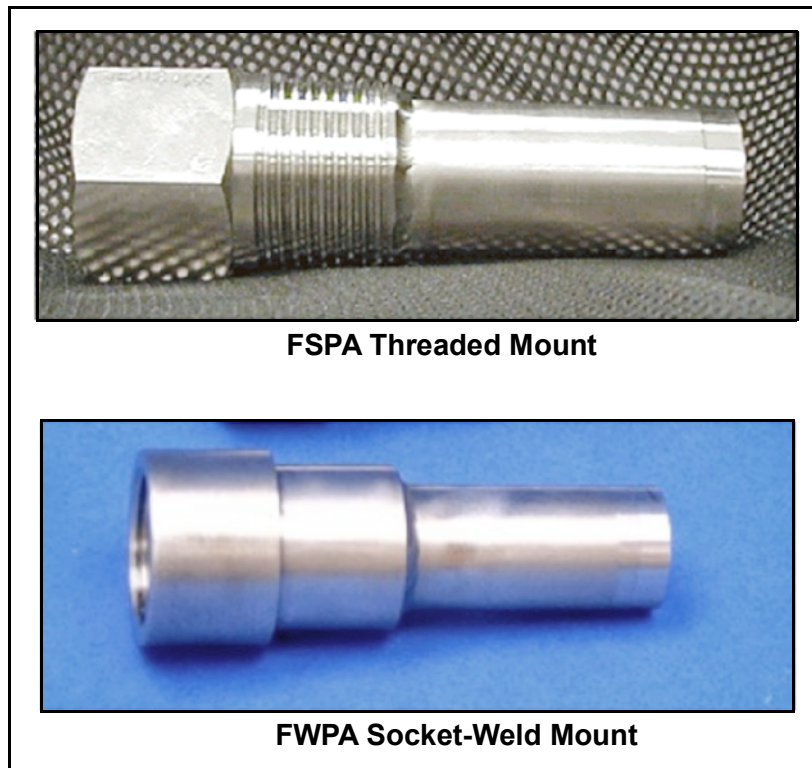
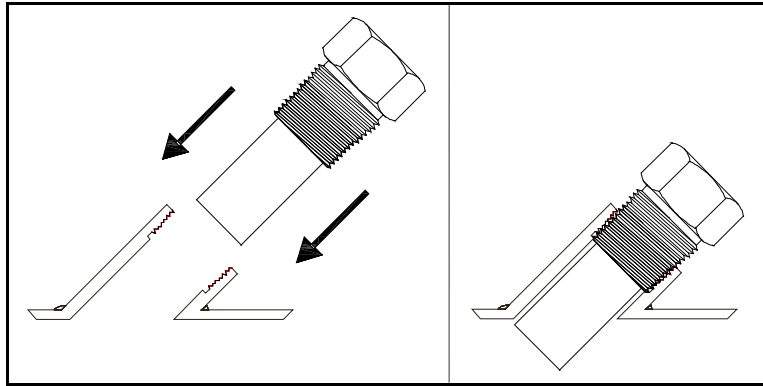

Figure 9: FSPA Buffer (Top) and FWPA Buffer (Bottom)

## 4.2 Installing the FSPA or FWPA Buffer

Both types of buffers are easily installed into the pipe coupling or flange as follows:

- **FSPA Threaded Mount:** Use Teflon<sup>®</sup> tape thread sealant on the buffer threads and screw the buffer into the transducer port. Hand-tightening the NPT threads will seal the connection without torquing.



- **FWPA Socket-Weld Mount:** Insert the buffer into the meter body transducer port and weld it to the port in accordance with all applicable safety codes and procedures.



**WARNING!** Welding should be performed by qualified personnel only. Safety personnel should be consulted.

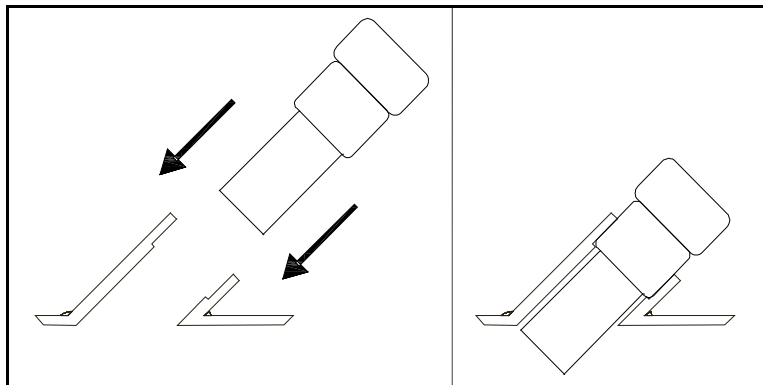

### 4.3 Installing and Orienting the Junction Box

Before placing the BWT transducer into the FSPA/FWPA buffer permanently, you must make sure the transducer junction box will be properly oriented after it is installed.

**Note:** The figures below show the FSPA Buffer only as an example.

1. Screw the transducer into the junction box as shown below.

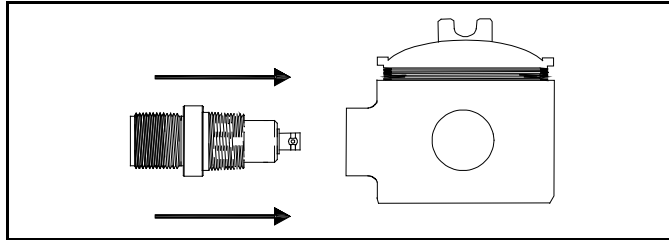

2. Screw the transducer/junction box assembly into the FSPA/FWPA buffer.

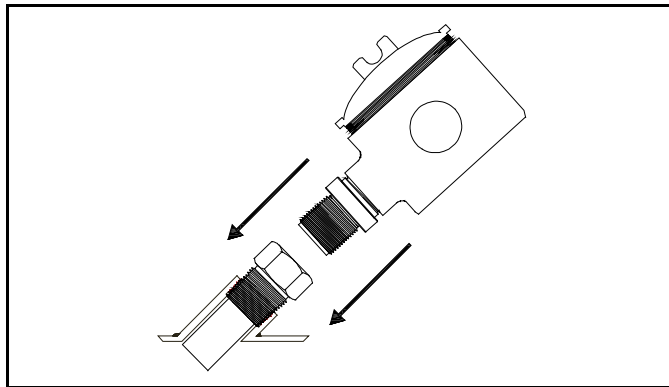

3. Check the junction box orientation. The junction box cover should be at a downward angle so that any liquid can drain out of the box. If necessary, adjust the junction box until the cover is angled downward.

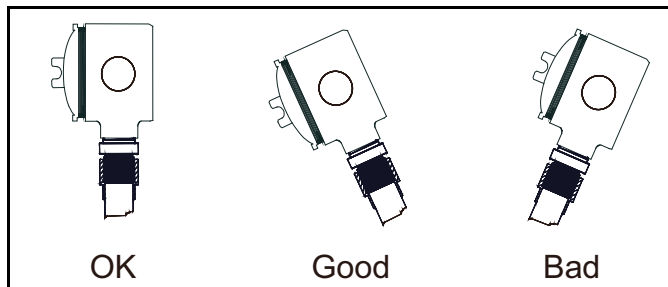

4. Remove the transducer/junction box assembly.
5. Repeat the above steps for the other transducer.

## 4.4 Inserting the BWT Transducers



**WARNING!** Follow all applicable safety codes and safety procedures when installing or removing the plugs.

1. As shown below, place a small droplet (2 mm in diameter) of 3M Epoxy or equivalent on the center of the transducer face (the picture below shows the transducer without the junction box).



2. Hand-tighten transducer, then torque it to a maximum of 15 ft-lb (20 N-m).
3. Verify that the junction box is properly oriented as discussed in the previous section (see page 37).

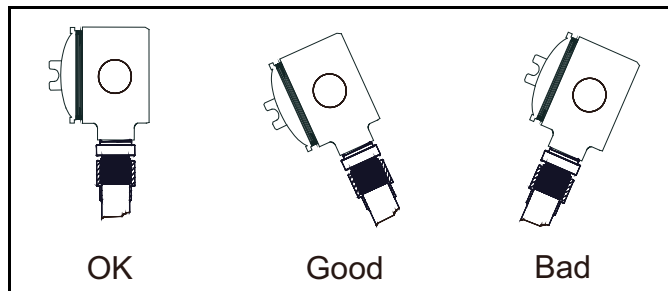

4. To connect the required cables from the junction boxes to the electronics, see the *Startup* or *User's Manual* that was supplied with your flowmeter.

## 4.5 Verifying the Installation

To verify that the installation is working properly, complete the following steps:

1. Power up the electronics.
2. Refer to *Displaying Diagnostics* in the flowmeter *Service* or *User's Manual* to display the upstream and downstream transducer signal strength.
3. Record this data in the *Service Record* in the appendix provided for this purpose in the flowmeter *Service* or *User's Manual*.
4. Verify that the signal strength diagnostics readings are the same or better after 8 hours of operation.

This completes the installation of the FSPA/FWPA buffers and transducers. Refer to the flowmeter *Startup Guide* or *User's Manual* for instructions on obtaining flow rate measurements.

[no content intended for this page]



## Chapter 5. Specifications

### 5.1 Transducers

#### Designation

BWT1

#### Material

316L stainless steel

#### Mounting

1 1/4 in straight UN thread

#### Connectors

- *Standard:* BNC
- *Optional:* Submersible

#### Temperature

-58°F to 212°F (-50°C to 100°C)

#### Frequencies

- 200 kHz for gases and steam
- 500 kHz or 1 MHz for liquids, depending on the application

### 5.2 Flanged Buffer Assemblies

#### Service

Liquids, gases and steam

#### Mountings

Lap joint flange, RF, 1.5 inch, 150#, 300#, 600#, 900#, 1500# and 2500# ANSI

#### Materials

- *Standard:* 316L stainless steel
- *Optional:* Titanium (FTPA/FIPA short buffers only), available to meet EN10243.1.B and/or NACE requirements

#### Pressure

To maximum allowable flange operating pressure at temperature or 3480 psi (240 bar)

#### FTPA/FIPA Short Buffers

- *Fluid temperature:* -310°F to 600°F (-190°C to 315°C)
- *Minimum pressure (gas service):* typically 100 psi (6.9 bar), depending on fluid density

#### FTPA/FIPA Extended Buffers

- *Fluid temperature. Liquids:* -310°F to 1,112°F (-190°C to 600°C)
- **Gases and steam:** -310°F to 842°F (-190°C to 450°C)
- *Minimum pressure (gas service):* typically 100 psi (6.9 bar), depending on fluid density

**Note:** Low-density, low-pressure gases use FIPA buffer assembly. No minimum pressure is required for liquid service. Consult Panametrics for individual application specifications. **Area Classifications**

## 5.3 Threaded Buffer Assemblies

### Service

Liquids

### Mounting

1 in. NPT

### Materials

- *Standard:* 316L stainless steel
- *Optional:* Titanium

### Fluid Temperature

- *FSPA Short Buffers:* -40°F to 212°F (-40°C to 100°C)
- *FSPA Extended Buffers:* -40°F to 600°F (-40°C to 315°C)

## 5.4 Socket-Weld Buffer Assemblies

### Service

Liquids

### Mounting

1 in. socket weld

### Material

*Standard:* 316L stainless steel

### Fluid Temperature

- *FSPA Short Buffers:* -40°F to 212°F (-40°C to 100°C)

## 5.5 System

### Area Classifications

- *Explosion-proof:* Class I, Division 1, Groups C&D
- *Flameproof:* BWT:  $\text{Ex}$  II 2 G Ex d IIC T6 Gb KEMA 01ATEX205I  
Ex d IIC T6 Gb IECEx KEM 09.0010
- **JB:**  $\text{Ex}$  II 2 G Ex d IIC T6 Gb DEKRA 13ATEX0120X  
Ex d IIC T6 Gb IECEx DEK 13.0034X

### European Compliance

Complies with directives 2004/108/EC EMC, 2006/95/EC LVD (Installation Category II, Pollution Degree 2), 94/9/EC ATEX and 97/23/EC PED for DN<25.

### Pipe Sizes

2 in. to 30 in. (50 mm to 750 mm), larger sizes upon request

### Velocity Ranges

- *Gas service:* 0.1 to 150 ft/s (0.03 to 46 m/s)
- *Liquid service:* 0.1 to 40 ft/s (0.03 to 12 m/s)

**Note:** The maximum flow velocity specification for gases is variable, depending on gas sound speed, ultrasonic path length and gas density (pressure and molecular weight).

**Note:** *For gas flow applications, a preamplifier is required. In such systems, the supplied preamplifiers may be mounted in the transducer junction boxes.*

[no content intended for this page]

---

## Warranty

Each instrument manufactured by Panametrics is warranted to be free from defects in material and workmanship. Liability under this warranty is limited to restoring the instrument to normal operation or replacing the instrument, at the sole discretion of Panametrics. Fuses and batteries are specifically excluded from any liability. This warranty is effective from the date of delivery to the original purchaser. If Panametrics determines that the equipment was defective, the warranty period is:

- one year from delivery for electronic or mechanical failures
- one year from delivery for sensor shelf life

If Panametrics determines that the equipment was damaged by misuse, improper installation, the use of unauthorized replacement parts, or operating conditions outside the guidelines specified by Panametrics, the repairs are not covered under this warranty.

---

**The warranties set forth herein are exclusive and are in lieu of all other warranties whether statutory, express or implied (including warranties or merchantability and fitness for a particular purpose, and warranties arising from course of dealing or usage or trade).**

---

## Return Policy

If a Panametrics instrument malfunctions within the warranty period, the following procedure must be completed:

1. Notify Panametrics, giving full details of the problem, and provide the model number and serial number of the instrument. If the nature of the problem indicates the need for factory service, Panametrics will issue a RETURN AUTHORIZATION NUMBER (RAN), and shipping instructions for the return of the instrument to a service center will be provided.
2. If Panametrics instructs you to send your instrument to a service center, it must be shipped prepaid to the authorized repair station indicated in the shipping instructions.
3. Upon receipt, Panametrics will evaluate the instrument to determine the cause of the malfunction.

Then, one of the following courses of action will then be taken:

- If the damage is covered under the terms of the warranty, the instrument will be repaired at no cost to the owner and returned.
- If Panametrics determines that the damage is not covered under the terms of the warranty, or if the warranty has expired, an estimate for the cost of the repairs at standard rates will be provided. Upon receipt of the owner's approval to proceed, the instrument will be repaired and returned.

---

[no content intended for this page]

---

# Certification & Safety Statements for the BWT Ultrasonic Flow Transducer

When installing this apparatus in potentially hazardous areas, the following requirements must be met:

- The installation should comply with IEC / EN 60079-14.
- The certification covers the Panametrics BWT transducer fitted with a Panametrics JB 6819 enclosure or with an ELFIT Sx-36 enclosure assembly. The enclosure assembly may contain a 705-1099 low power signal pre-amplifier. Assemblies using the ELFIT enclosures are ATEX certified only; they are not IECEx certified.
- This apparatus is equipment category 2 / EPL Gb and may be installed in zone 1 and 2 areas. It may not be used in a zone 0 area. This apparatus is certified for gas hazards only. It has not been assessed to dust hazards.
- The apparatus certification is valid for the ambient and process temperature range combinations listed on page 2. This is not the operational temperature range of the apparatus - check supplied documentation for operational limits.
- Field wiring shall be rated at least 10°C above ambient.
- The product contains no exposed parts which produce high surface temperatures or infrared, electromagnetic or ionizing radiation. The product must not be subjected to mechanical or thermal stresses in excess of those permitted in the certification documentation and the instruction manual. The apparatus shall be protected from external sources of heating or cooling by the use of a Buffer assembly, see the Specification chapter of the transducer manual.
- There are no internal sources of ignition in normal operation.
- The product is an electrical apparatus and must be installed in the hazardous area in accordance with the requirements of the product certification. The installation must be carried out in accordance with all the appropriate international, national and local regulations, codes and practices and site requirements for flameproof apparatus and in accordance with the instructions contained in the manual. The installation should comply with IEC / EN 60079-14.
- To avoid an ignition hazard, protect the transducer from impact or friction. This is of particular importance when the material of construction is titanium.
- The apparatus must be securely attached to the site of the flow measurement. Before installation, check that the transducer, adapter and enclosure are firmly locked together. The transducer assembly must be attached to the buffer assembly as detailed in the user manual. Measures must be taken to ensure a good electrical contact and to prevent the threads from self-loosening. An inspection of the joints should be added to the routine maintenance schedule.
- To avoid electrical shock, the transducer must be mounted to a metal, electrically grounded, pipe system.
- A cable lug shall be used for all connections to the apparatus' earth points.
- Each cover is fitted with a locking device. This device must be loosened before opening the cover. It must be tightened after the cover is replaced so as to preserve the protection provided by the enclosure. Access to the circuitry must not be made during operation; the apparatus should be de-energized before opening.
- Modifications to the flameproof enclosure are not permitted.
- Cable entry devices of an appropriate, IECEx or ATEX, approved flameproof design are required. These must be installed according to the manufacturer's instructions. Connecting cables shall be mounted securely and protected from mechanical damage, pulling and twisting. Cable entries are ¾" NPT, 1" NPT or M20 x1.5 (see product markings).
- Only trained, competent personnel may install, operate and maintain the equipment.
- The product cannot be repaired by the user; it must be replaced by an equivalent certified product. Repairs should only be carried out by the manufacturer or by an approved repairer.

## Special Conditions for Safe Use

- Consult the manufacturer if dimensional information on the flameproof joints is necessary.
- To avoid an ignition hazard, protect the transducer from impact or friction. This is of particular importance when the material of construction is titanium.

## EU/EEA Installation Compliance

The use of this apparatus is subject to the EU directive on minimum requirements for improving the safety and health protection of workers potentially at risk from explosive atmospheres, Council Directive 1999/92/EC. The installer is required to be familiar with this document or the National transposing legislation.

**BWT Transducer/Junction Box Details**

Manufacturer and certificate owner:	Panametrics Sensing Inc, Billerica, MA 01821, USA.
Alternative manufacturing site:	Baker Hughes EMEA, Shannon, Co. Clare, Ireland
QAN License Number:	0794
Notified Body for Quality Assurance Notification:	SGS Baseefa
Notified Body Number:	1180
Certificate Number:	KEMA 01ATEX2051; IECEx KEM 09.0010
Apparatus Markings (see example below):	II 2 G Ex d IIC T6 Gb -40°C < Tamb < +70°C

Examples of Markings

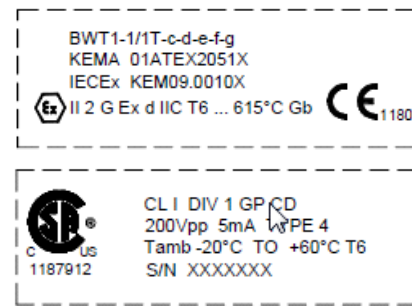
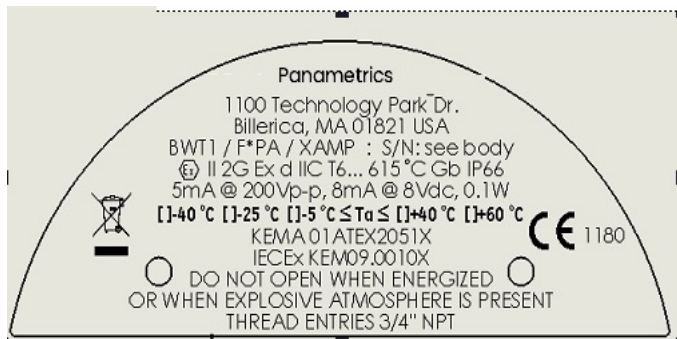

**BWT Transducer Body**

[Serial number format is MMYYNNNN, where MMY Y is month and year of construction and NNNN is a sequential number.]

Thermal Data

The relation between process temperature, ambient temperature and temperature class is shown in the table below.

Max. Process Temp.	Max. Ambient Temp. (XAMP / No XAMP)	Buffer Length	Temp. Class
+70 °C	+40 °C / +60 °C	0" / 2" / 6" / 10"	T6
+85 °C	+40 °C / +60 °C	2" / 6" / 10"	T5
+120 °C	+40 °C / +60 °C	2" / 6" / 10"	T4
+175 °C	+40 °C / +60 °C	2" / 6" / 10"	T3
+285 °C	+40 °C / +60 °C	2" (SS only) / 6" / 10"	T2
+435 °C	+40 °C / +60 °C	6" / 10"	T1
+565 °C	+40 °C / +60 °C	6" / 10"	580°C
+600 °C	+40 °C / +60 °C	10"	615°C
Min. Process Temp.	Min. Ambient Temp.	Buffer Length	
-40 °C	-40 °C	0" / 2" / 6" / 10"	
-194 °C	-5 °C	2"	
-194 °C	-25 °C	6" / 10"	





## Customer Support Centers

### U.S.A.

The Boston Center  
1100 Technology Park Drive  
Billerica, MA 01821

U.S.A.

Tel: 800 833 9438 (toll-free)  
978 437 1000

E-mail: [mstechsupport@bakerhughes.com](mailto:mstechsupport@bakerhughes.com)

### Ireland

Sensing House  
Shannon Free Zone East  
Shannon, County Clare  
Ireland

Tel: +353 61 61470200

E-mail: [mstechsupport@bakerhughes.com](mailto:mstechsupport@bakerhughes.com)

Copyright 2021 Baker Hughes company.

This material contains one or more registered trademarks of Baker Hughes Company and its subsidiaries in one or more countries. All third-party product and company names are trademarks of their respective holders.

916-058 F

**Baker Hughes** 