

.401 Herter Powermags

by Lee Martin
(Arlington, Virginia)

The criticisms usually go something like this: “They’re no Ruger, certainly no Colt, they’re ugly, and were grossly over-hyped by their creator”. Short of the obvious, Herter’s single action revolver wasn’t that bad a pistol. I believe that many of the people that hold such disregard for the gun have never had any experience in shooting them. The other “unknown” seems to be Herter’s proprietary .401 Powermag round. What is it? Where do you get brass? Where can loading data be obtained?

As most of you know, George Herter ran a large outdoor hunting and shooting-supply company that was based out of Waseca, Minnesota. Operations came to an end in the early 1980s when much of the business was sold. Though this was before my time, my dad does remember their mail order catalogue as being quite extensive. Shooting supplies were offered to include long-guns, pistols, reloading dies, loaded ammunition, scopes, etc. Then came the Gun Control Act of 1968, which severely impacted the firearm side of their business. This event certainly promoted the downfall of the Herter’s single action revolver which was offered in .357, .401, and .44 Magnum..

I first heard of a .401 Powermag back in 1991. My dad and I were talking about the .41 Magnum when he mentioned the round. At the time, I thought the name sounded catchy and being a fan of the middle-bores I immediately became interested. Dad briefly described the cartridge as being the work of George Herter and indicated that it was only offered in a sub-par quality single action; namely the Herter Powermag. He also remembers that they sold for around \$50.00 in the early to mid-sixties. Now mind you, this was in a time when a Ruger Blackhawk listed for \$89.95 and the Super Blackhawk went for a tad over \$100.00. It’s not hard to see why people may have considered the Powermag to be cheaply made. Dad’s advice was to stick with the .41

Blackhawks and forget the whole Powermag thing. Unfortunately, I'm a sucker for the underdog and still hoped to find a Herters in .401.

Not much has been written about the round other than it was developed in 1961 and is similar to the .41 Magnum. Frank DeHaas wrote an excellent article in the March-April 1992 issue of Rifle Magazine on mid-caliber pistol rounds. Though he focused more on the .401 Eimer and .401 Boser, he did mention the Powermag. John Taffin's "Big Bore Sixguns" also has some good perspective on the cartridge, especially the excerpts on how it was advertised. Though it would be wrong to label the Powermag as the first 10mm magnum, it was the first to be offered commercially. The .41 Remington Magnum did not come along until three years later and of course used a .410" bullet.

For 10 years I hoped to find a Herters but never had much luck. Ones that I had seen in Gun List or within on-line auctions were either in less than stellar condition or were excessively priced. I did run across a .401 at a Pittsburgh gun show back in '97, but being a Virginia resident prevented me from purchasing the gun (I probably should have had it shipped to a local FFL holder, but oh-well). Then within a two month period I found both a .357 and .401 Powermag that were \$185 and \$200 respectively. More important than the price was the fact that the guns looked to have been used sparingly. The actions were tight, the bores were in great condition, and the bluing was 95%+. I should note that there is little market for these single actions. The book value on any of the chamberings is \$200 in excellent or above and \$150 - \$175 in VG/VG+. Secondly, if you do locate a .401 Powermag, the cost to shoot it will be nearly as much as the gun due to the scarceness of reloading components (ie, dies & brass).

The pistols were manufactured by J.P. Sauer and Sohn of West Germany and were imported by Herters (the Sauer and Sohn name was never written on the gun). "Manufactured in West Germany" was present on the left side of the barrel though, as was the "Herters Waseca MINN USA" label. Also inscribed on the left side was the serial number and proof marks which indicated the year of production (the latter was a two-digit ID). The right side of the 1:14" twist barrel contained, "Herters Single, 401 Calibre". Overall the pistols were well built, and had bluing that was in-line with that of their Ruger counterpart. What really stands out is the design of the Powermags. "Unsightly" is a word that often comes to mind, as I can't help but view them as a bad cross between a Colt New Frontier and a Blackhawk.

If two features detracted from the lines of the Powermag it was definitely the grip-shape and rear sight configuration. The back-strap alone can only be described as bizarre. It was a two-piece design like the Colt Single-Action Army and made use of individual grip panels such as the Ruger. The front side of the frame had a very pronounced inward curve from top to bottom,

not unlike the old Colt Bisley. The backside profile has a higher arch than a Blackhawk and reminds me of that of a Freedom Arms (though it isn't comparable in terms of how it fits your hand). What you're left with is a tall, narrow grip that takes a lot of getting used to. None of this is improved by the grips either. Molded out of black plastic and in-laid with the Herters logo, they do little to enhance how the gun is held. Short of being plastic, my biggest complaint is that they're too squared off on the back edge. In other words, there's no front to back convexity, especially on the top half. The Powermags also used a flat trigger spring as opposed to the more modern coil design.

The hammer and top-strap can also be considered "unique". With respect to the former, a wide spur was used in conjunction with an internal firing pin. I've always considered them to be odd for a couple of reasons. First, they were wide like that of the Super Blackhawk yet the spur was somewhat stubby in overall length. Secondly, the front half had a large extension that protruded into the frame as to strike the firing pin. It's hard to describe the shape so I've included a picture of the hammer below. Similar to the Rugers of that time, no transfer-bar system was employed so these were all "half-cock" mechanisms.

George Herter referred to them as "sight protectors" and truthfully they did serve that purpose. To everyone else they appeared to be oversized humps on the back portion of the top strap. Originally, I didn't like them but in time viewed them as the sort of feature that gave the gun character. When combined with the tall ramp front blade, the adjustable sights work well. I was also pleased with the lock-up on both of my pistols. Cylinder gap is certainly not custom grade, but is in-line with most other mass-produced single actions. I would say that both of my Powermags are as tight when in battery as the Rugers of that time. What isn't comparable is the feel of the action. Without a doubt, the Rugers are much smoother to thumb and the triggers are infinitely better. My .357 Powermag has one of the heaviest trigger pulls of any single in my collection. The .401 of the other hand is extremely light and most likely the result of an aftermarket trigger job. Another shortfall of the Herter SAA was the base pins. All were similar to that of the Colt Peacekeeper but were less than user friendly. Much of this is due to their rough finish.

Brass for the .401 Powermag is obscure. Originally, Norma produced cases for the .401 that were head-stamped with the Herter name (the official stamp was 401 Herter Mag). Currently, the only source that I know of is Buffalo Arms and they charge \$52.00 per 100. Interestingly enough, they denote their cases as being formed off of another round and this brings me to my next point. Unless you want to go to the trouble of locating original .401 shells, shooting the Powermag becomes a roll-your-own proposition (I've seen original loaded Powermag go as high as \$100 per 50). Two avenues for doing so exist: 1)

Downsize .41 Magnum cases, or 2) Make the Powermag off of common .30-30 brass. I've done the former, have never tried the latter, and know for a fact that both work well. The four reasons I prefer to use .41 Mag brass is that case trimming is minimal, no rim modification is necessary, the rounds are extremely close with respect to outside dimensions, and case capacity is slightly reduced when using the .30-30. Overall, the Powermag is 0.004" shorter than the .41 and is roughly 0.007" smaller in diameter. Since all of the .401 cylinders are recessed, rim thickness and size was originally a concern. As it turns out, the rim of a .41 Mag case perfectly fits in the cylinder recesses on my gun. The next step was to downsize the .41 case by 0.007" using a die that was bored to 0.426" (the brass is worked less if the new case is first run through a .41 Magnum sizing die). The final step is to trim the Powermag shell to an overall length of 1.285".

.401 HERTERS POWERMAG

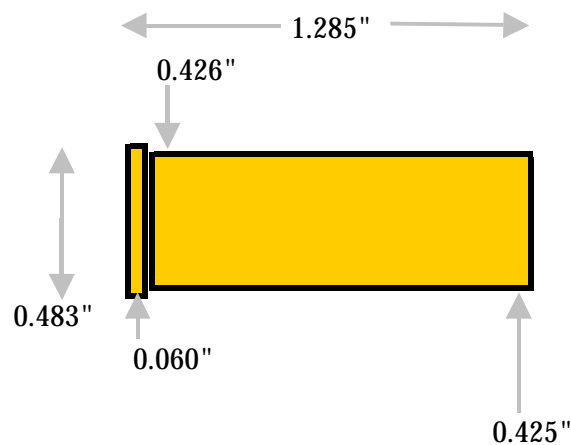

Loading the .401 Powermag quickly becomes obvious. With dimensions being nearly that of the .41 Magnum, I've used the loads interchangeably. As earlier noted, if the .30-30 is used as the parent case, capacity will be slightly reduced. Otherwise, .41 Magnum loads work fine. Herter's offered bullet weights to include 160, 180 and 200; to date I've primarily worked with the 200 grain and found them to shoot well. I have emails from a few people indicating that they've tried the 265 grain cast bullet that was originally for the 40-65 Winchester. Though I've used this weight in my .401 Bobcat, I've never tried it in a Powermag. Regardless, a wide range of 10mm bullets exist for this cartridge. Some select Powermag loads include (See Appendix #1).

Inter-changeability of loads with the .41 Magnum speaks volumes about .401 Powermag performance.....namely, that the two are identical in the output department. Herter was neither as realistic nor as modest in how he described the cartridge's capability. For one, he stated that the Powermag would drop any man or beast, regardless of bullet placement. He also touted the round as being excellent on all large game, including the African variety. Beyond this hype, original .401 factory loads were much maligned because of their soft-swag lead bullets. I've also read that they were extremely hot to the point that case extraction was difficult. One account went as far as to specify that a shell had to be reamed out of the cylinder to clear the gun (I guess these "nuclear" type loads were necessary for "stopping any man or beast no matter where you hit them"). Reloading the round to .41 mag limits however proves accurate, very shootable, and useful on small to medium sized game (my 1969 Herter catalogue has a picture of 4 bobcats that were all taken with a .401 and another one of a downed moose).

Variants of the Herter's Powermag are few and far between. Even if they existed, their value would be limited due to a lack of interest in these single-actions. There are two oddities that I'm aware of, yet I believe them to be of more myth than fact. The first is that a 4.5" barreled version was built in .357, .401, and .44 Magnum. In spite of many gun valuation guides listing such a Powermag, I've never seen even a picture of one (to that end they all appear to be 6.5" models). Another suspected variant involves a double-action .401 that was aimed at the law enforcement segment in mid-to-late 1960s. Apparently, the 1968 Herter Guide listed the pistol, but again I've never seen the gun or a photo. Sauer & Sohn did catalogue a double action revolver around this time, so it's possible that a prototype was built.

I hope that this article is useful to anyone that shoots these revolvers. For whatever reputation they may have, I really like the old Powermags. They were cheap and not as smooth as the Ruger Blackhawk, but they are strong and shoot pretty well. It's also important to note that George Herter's .401 predates the .41 Magnum by three years. Rumor has it that Remington initially considered a 10mm bullet since the .38-40 had set some precedent as a pistol caliber. Whether the .401's introduction in 1961 did anything to influence the use of the .410" diameter in 1964 remains to be seen. Colt had a similar cartridge drawn up in the 1960's that was named the .400 Colt Magnum. Interestingly enough, experimental cases were made and many have found their way into cartridge collections worldwide. The pictures I've seen of the .400 Colt show a close resemblance to the 401 Powermag.

Granted, George Herter did not invent the middle-bore magnum, but he was the first to push it commercially. Judging by the fact that Remington

introduced the .41 Magnum and Colt contemplated a similar chambering, the .401 did fill something of a market void. What truly killed the round though was not it's usefulness as a pistol cartridge, but instead the gun to which it was mated. It's been said that if the .401 Powermag had been stuffed in an N-frame and/or Blackhawk shell that the .41 Magnum would never have existed. If you're interested in acquiring a Powermag, I occasionally see them for sale on-line. You may try one of the following links:

<http://www.gunbroker.com>

<http://www.auctionarms.com>

<http://www.gunsamerica.com/>

Components and reloading dies can also be purchased from Buffalo Arms Co. at <http://www.buffaloarms.com>. Empty brass is priced at \$52.00 per 100 and 4-D dies list for \$84.00; neither is excessively high for something as obsolete as the .401. Powermag style single-actions were also sold by Hawes under the "Chief Marshall" designation. Sauer and Sohn again did the manufacturing except the Marshall version had wood grip panels. Chamberings included .357, .44 Mag, and .45 Colt.

If you have any questions or have additional information on the Herter Powermags, please contact me at sc429@yahoo.com.

NOTE - this article was written in early 2002. Since then, the price of .401 Powermags has risen to the \$350 - \$400 range.



L to Right: .401 Powermag, .41 Rem Mag, .401 Bobcat



Top: .401 Herter Powermag, Bottom: .357 Magnum



.401 Powermag: View of the hammer.



Powermags with the 1969 Herter catalogue

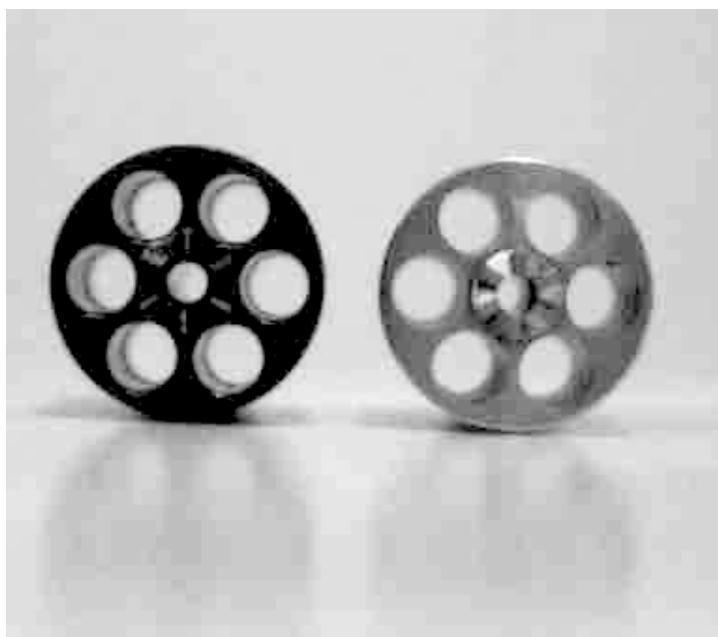

Cylinders: Left, .401 Powermag, Right, Ruger Blackhawk in .44-40. Both are similar in size



**SAUER-WESTERN-
SIX-SHOOTER**

Single-Action-Revolver

Kaliber .357 Magnum
.44 Magnum
.45 Colt

Gewicht 1,3 bis 1,4 kg

Laufänge 16,5 cm
14 cm

Der Revolver zeichnet sich durch die Präzision seiner Ganzstahl-Ausführung aus und eignet sich damit auch zum Scheibenschießen. Die Waffe hat ein verstellbares Visier mit Rechteckkorn und Balkenkorn. Alle Stahlteile sind schwarz brüniert. Die Griffschalen sind aus Nußbaumholz und werden auf Wunsch auch in einer schwarzen Kunststoffausführung geliefert.



Original Sauer & Sohn catalogue listing for the Western Six-Shooter. This was the gun that all of the Powermags were based on.

Appendix #1

BULLET WT	POWDER	CHARGE (gr)	VEL (fps)
160	Unique	11.0	1,330
180	H110	20.5	1,315
180	Unique	10.0	1,255
200	W296	19.0	1,270
200	Unique	8.5	1,150
200	Blue Dot	13.0	1,275