

Permeate to Destination or back to CIP System
xx gpm @ 5 psi

Concentrate to Destination or back to CIP System
xx gpm @ 5 psi (avg)
xx gpm @ 5 psi (Inst. Batch)

Hot Water In
30gpm @ 1.5 psi.
<300uS and
30-60degC
(Intermittent Use)

Note:
All motors are full stop.
All pneumatic valves are fail close.

- Customer Components Provided:
- 1) Tanks with associated equipment
 - 2) Levels and other Instruments
 - 3) Transfer Pumps and motor starters
 - 4) Hot Water Tank or In-line Heaters
 - 5) Sump with associated equipment
 - 6) Valves and Piping
 - 7) Electrical Load Panel, CBs, and Generator or Transformer
 - 8) Crane or Lift
 - 9) Catwalk or Ladder
 - 10) Plant Air or Compressor
 - 11) Other equipment as recommended
 - 12) CIP System
 - 13) Chemical Metering System

- NLR System Components Provided:
- 1) 3A VSEP Unit with 3A 84" Filter Pack
 - 2) Premium Combo 3A Skid Assembly
 - 3) 3A VSEP Plumbing Interconnection

Notes:
NLR Confidential Material
Preliminary - For Reference
Only.

Revision	NEW LOGIC RESEARCH		
	84" VSEP 3A System		
	P&ID		
August 2020			A. DeSchuer

ISO VIEW

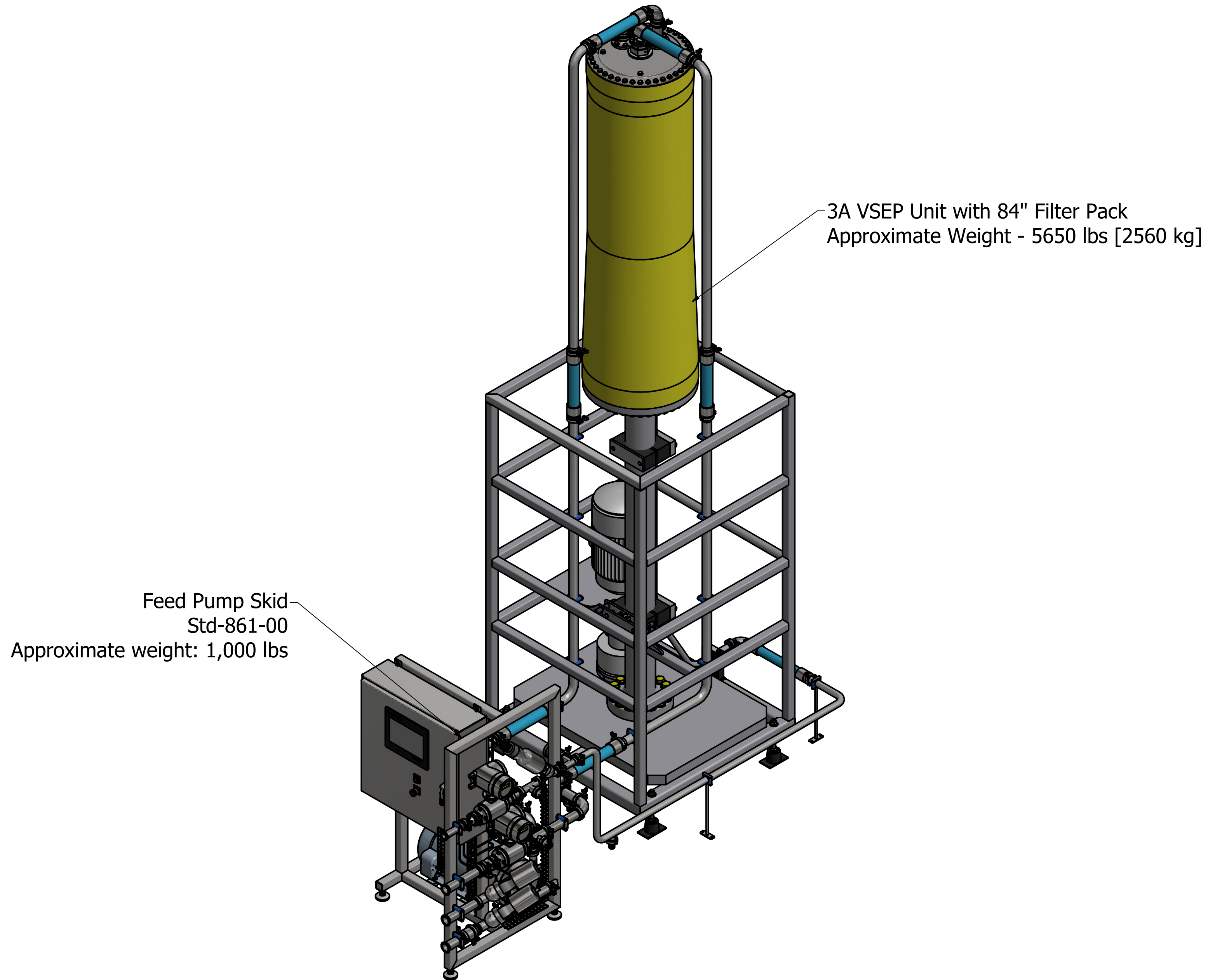

Notes:

- 1. New Logic Research Confidential material
- 2. Slight differences between drawings and actual system may be attributed to New Logic Research continuously evolving and improving its technology.
- 3. All dimensions are shown in inches [mm]

84" 3A Standard System

SIDE VIEW

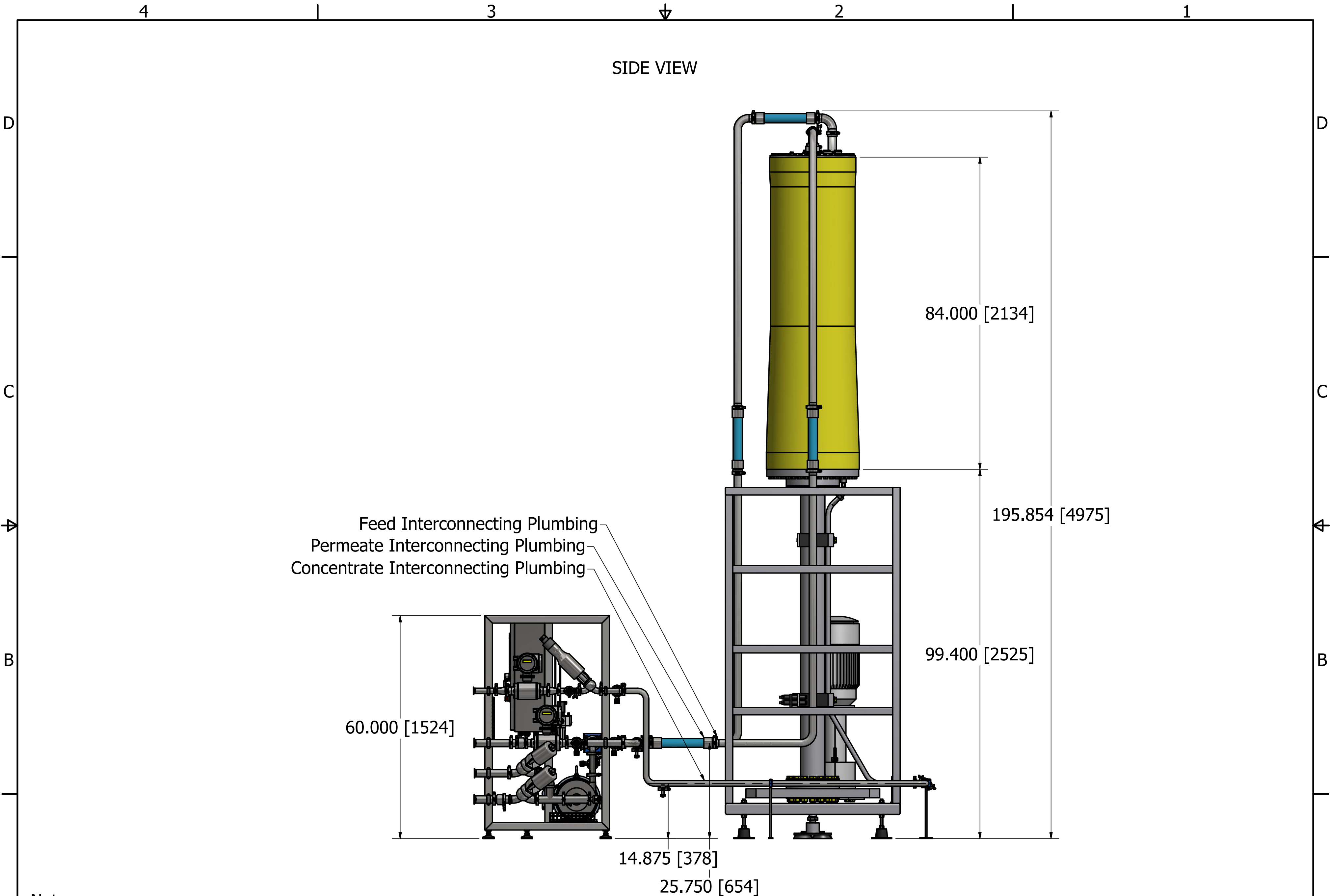

- Notes:
- 1. New Logic Research Confidential material
 - 2. Slight differenes between drawings and actual system may be attributed to New Logic Research continuously evolving and improving its technology.
 - 3. All dimensions are shown in inches [mm]

84" 3A Standard System

TOP VIEW

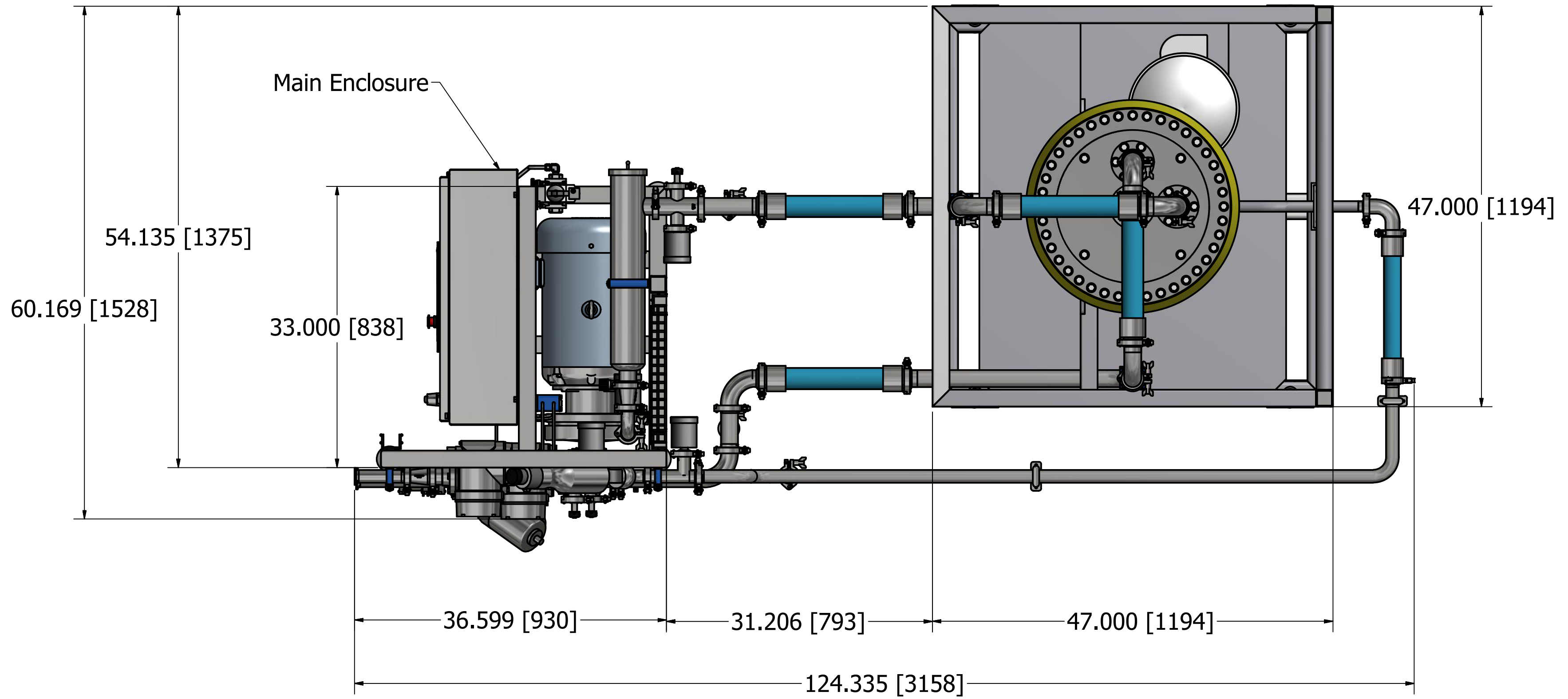

Notes:

- 1. New Logic Research Confidential material
- 2. Slight differences between drawings and actual system may be attributed to New Logic Research continuously evolving and improving its technology.
- 3. All dimensions are shown in inches [mm]

84" 3A Standard System

4

3

2

1

ISO VIEW

Enclosure
A-30H3008SSLP3PT

Pump Skid Frame
Std-861-01

Concentrate Plumbing
Std-861-02-02

Permeate Plumbing
Std-861-02-01

Hot Water Inlet

Feed Pump
Waukesha WCB 2085LV 256JM

Feed Inlet

Notes:

- 1. New Logic Research Confidential material
- 2. Slight differenes between drawings and actual system may be attributed to New Logic Research continuously evolving and improving its technology.
- 3. All dimensions are shown in inches [mm]

84" 3A Standard System

D

D

C

C

B

B

A

A

4

3

2

1

FRONT VIEW

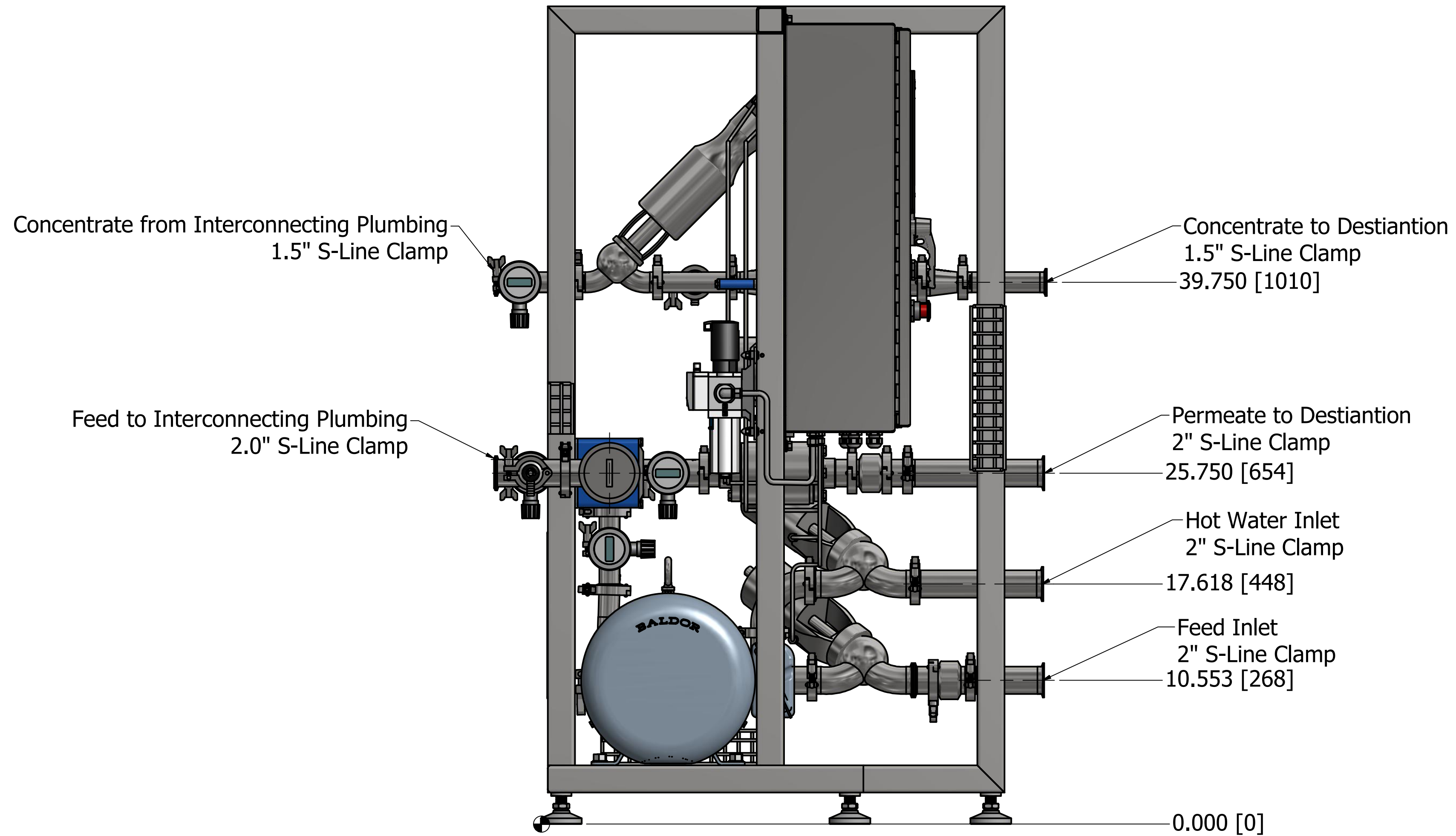

Notes:

- 1. New Logic Research Confidential material
- 2. Slight differenes between drawings and actual system may be attributed to New Logic Research continuously evolving and improving its technology.
- 3. All dimensions are shown in inches [mm]

84" 3A Standard System

4

3

2

1

ISO VIEW

D

D

C

C

B

B

A

A

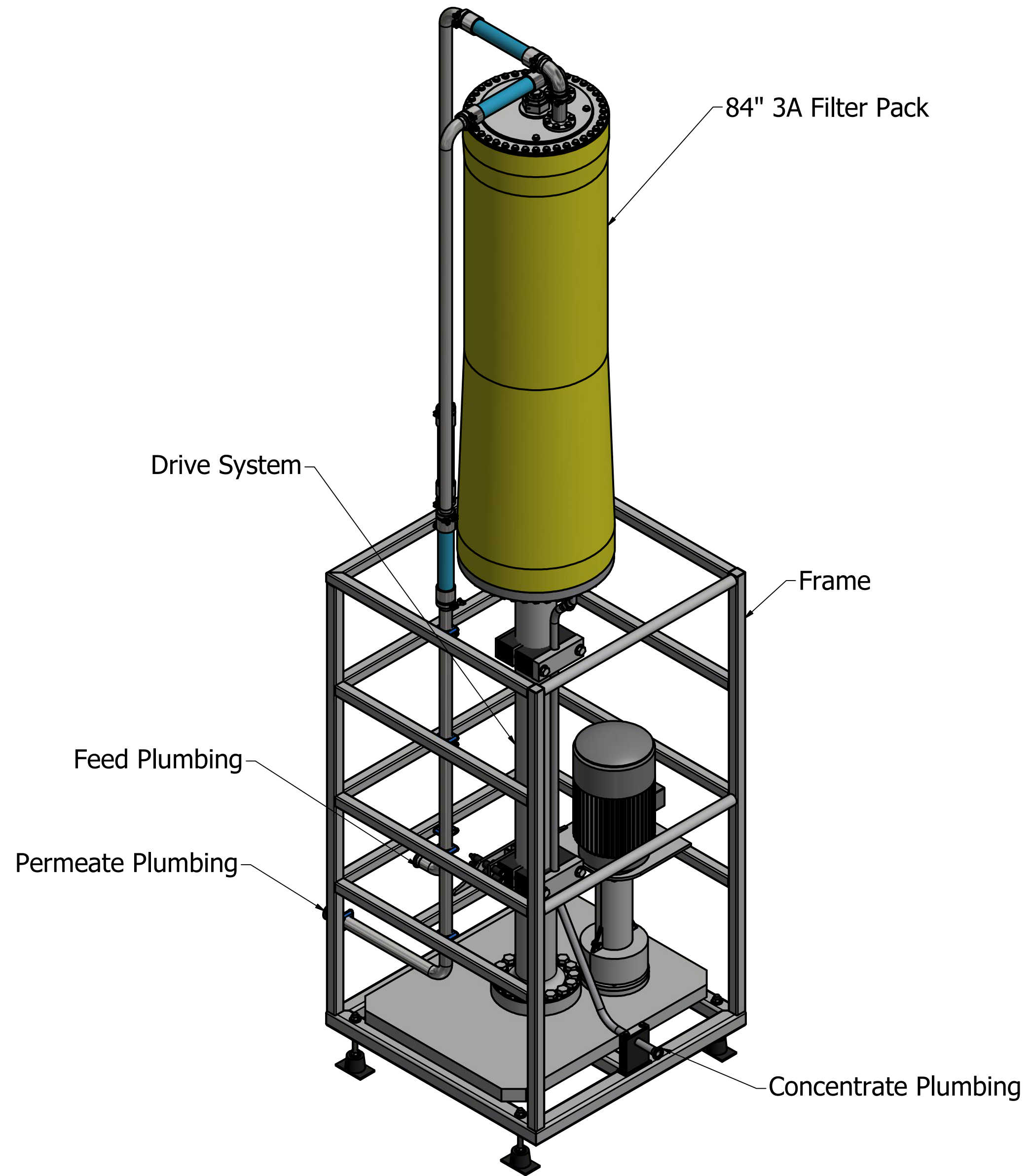

84" 3A Filter Pack

Drive System

Frame

Feed Plumbing

Permeate Plumbing

Concentrate Plumbing

- Notes:
1. New Logic Research Confidential material
 2. Slight differenes between drawings and actual system may be attributed to New Logic Research continuously evolving and improving its technology.
 3. All dimensions are shown in inches [mm]

84" 3A Standard System

4

3

2

1

VSEP SYSTEM COMPONENT SPECIFICATIONS

84" VSEP 3A Sanitary System

1] Filter Pack:

Membrane:	MF, UF, NF, RO (depends on application and pilot testing)
Allowable Process Temperature:	5°-60°C (some membranes have higher limits up to 120°C)
Max Process Pressure:	550 psi (3,800 kPa)
Allowable Feed Slurry pH Range:	2-12 (some membranes have different limits 1-13)
O-ring and Seal Material:	FG EPDM (option for Viton)
Filter Pack Housing:	Glass impregnated epoxy resin (FRP)
Wetted Steel Trays:	304 Stainless Steel (option for 316)
Wetted Plastic End Plates:	Polypropylene

2] Vibration System:

Vibration Drive Motor:	Baldor 460VAC, 3phase, 20HP, 3525 RPM
Motor Speed Controller:	Danfoss 20HP 380-480VAC, NEMA 4 (or Equal)
Max. Vibration Amplitude:	3/4 inch (peak to peak measured at the Filter Pack)
Frequency Range:	43.0 Hz to 55.0 Hz (Approximate)
Maximum Decibels:	<85
Bearing RPM:	2800 to 3100
Bearing Oil:	Sullube ~750 ml Compressor Oil
Bearing O-rings:	2-263 & 2-270 Buna

3] Pump Specifications:

Feed Pump Type:	Waukesha 316SS Horizontal Centrifugal
Feed Pump Motor:	Baldor 158TC 460VAC, 3phase, washdown
Motor Speed Controller:	Danfoss 380-480VAC, NEMA 4 (or Equal)
Chemical Metering Pump:	Bran+Luebbe Diaphragm pump with manual stroke adjust

4] Pre-Screen Basket Strainer:

Filter Housing Type:	Sanimatic Short Angle Line Strainer
Basket Strainer:	17 Mesh 316 SS
Capacity:	120 GPM, 1 sqft
Elastomers (Seals):	FG EPDM (option for Viton)

5] Operating Site Conditions:

Equipment Rating:	NEMA 4, Indoor/Outdoor protect from sunlight & rain.
Ambient Temperature:	5° - 37°C
Storage Temperature:	2° - 70°C (Protect Filter Pack from Freezing)
Max Relative Humidity:	<95%, non-condensing
Elevation:	3300 ft maximum without derating VFD/Motor

VSEP SYSTEM COMPONENT SPECIFICATIONS (continued)**6] Piping:**

High Pressure Piping:	Polished Tubing 316 SS
Low Pressure Piping:	Polished Tubing 316 SS
Special VSEP Concentrate Pipe:	1-1/4" OD 316L Stainless Steel Polished Tubing .065 wall
Flexible Hoses:	Teflon Lined Reinforced Flex Hose
Pipe Clamps:	S-Line/I-Line FG EPDM
Pneumatic Air Supply:	90lb Instrument Grade Air (3/8" connection)
Tubing Fittings:	none
Clean in Place Tank:	none
On/Off Valves:	316 SS ball valve
Manual Valves:	316 SS
Flow Control Valves	316 SS V-port ball valve
Check Valves	316 SS
Pneumatic Actuators	Waukesha Cherry-Burrell L-type W61
Positioners:	Waukesha Cherry-Burrell Throttling W68
Skid Pipe Terminations:	S-Line 316 SS Clamps

4] Electrical:

Controls Voltage:	120/220VAC, 1phase, 15A, 50/60Hz
Enclosures:	Hoffman NEMA 4 304 SS Finish, 30x30x8
Switches, Relays, & Contactors:	Allen Bradley 120/220 Volt
Remote Access:	Ewon Cosy 131
Programmable Controller:	AB CompactLogix 1769
Operator Display:	AB Versa View 5400
IO Link Masters and Hubs:	IFM Efector AL1122
Pressure Sensors:	Anderson Neegle SR075G004G1100
Mag Flow Tube and Transmitter:	Endress and Hauser 53H501F0BEAB0BBAACBZ1
Temperature Sensor:	Anderson Neegle TD 2813
Solenoid Valves:	Festo Manifold Gang Mounted Dual 3/2 24 VDC, IO Link

Utility Summary				New Logic Research		
VSEP System						
AIR COMPRESSOR SIZING INFORMATION						
	# of Valves	In ³ Air/stroke	Strokes/day	CFM	M3/hr	
VSEP						
2" Pneumatic Valves	2	60	20	0.0010	0.0016	
1" Flow Control Valves	1	35	20	0.5003	0.8505	
System Air Totals			System Totals	0.50	0.8521	
Supply instrument grade dry air at 80-90 psi (560-630kPa)						
Supply air to enclosure mounted regulator/filter 3/8" NPT connection						
Totals do not include air for tools or other sources.						
HOT WATER SIZING INFORMATION						
Estimate for filter pack cleaning, does not include system CIP						
	# /Day	Temp degC	Gallons/Day	GPM	M3/hr	
VSEP						
Cleanings	1	50-60	1000	0.69	0.1576	
Rinse filter pack at 60gpm for 5mins	1	50-60	150	0.10	0.0236	
Intermittent need of additional cleaning or flush of filter pack	0.14	50-60	21	0.01	0.0033	
System Water Totals			System Totals	0.81	0.1846	
Supply chlorine free water at >300 uS/cm						
Supply water at 50-60degC and 30gpm (6.8m ³ /hr)						
Supply water at 15 psi to 2" Hot Water S-Line connection on Combo Skid						
ELECTRICAL LOAD PANEL SIZING INFORMATION						
Circuit Breaker Sizing 1.25-2x Nameplate Current						
3-Phase Power Voltage VAC	400-460	50/60 Hz				
1-Phase Power Voltage VAC	220-120	50/60 Hz				
	# Motors	Rated Motor HP	Nameplate Current	Nameplate Current	Recommended CB Sizing	
VSEP Drive Motor	1	20	400V 26.3	460V 24.0	40	
VSEP Feed Pump	1	20	26.3	24.0	40	
Totals		2				
Supply 3-Phase power from customer supplied load panel (with circuit breakers, disconnects, line filters, etc.) to the inlet of each VFD provided by New Logic.						
	# Connections	Rated Motor	Nameplate	Nameplate	Recommended	
			220V	120V		
Main Control Enclosures	1	NA	10	8.0	20	
Supply 1-phase power from customer supplied load panel (with circuit breakers, ups, etc.) to New Logic provided circuit breakers inside the Main VSEP control enclosure (PLC/HMI/24VDC Power Supply).						
Note: These are estimates only based on very preliminary data. These calculations are subject to change and do not include equipment offskid of VSEP system (ie: Transfer Pumps, Generators, Heaters, Lighting, Cranes, etc). For power consumption estimates refer to the operating cost spreadsheet.						