

# CONSUMER GUIDE TO ROOFING

## A guide for the selection of Roofing Services



ROOFING CONTRACTORS  
ASSOCIATION OF  
BRITISH COLUMBIA

9734—201 Street, Langley, BC V1M 3E8 604-882-9734  
Website: [www.rcabc.org](http://www.rcabc.org) Email: [roofing@rcabc.org](mailto:roofing@rcabc.org)

## Contents

SECTION 1 CONSUMER GUIDE TO ROOFING .....	2
SECTION 1.a CONSUMER TIPS ON BUYING A ROOF .....	2
SECTION 1.b CHOOSING THE RIGHT MATERIAL FOR STEEP ROOFS.....	3
SECTION 1.c CHOOSING THE RIGHT MATERIAL FOR LOW SLOPE/FLAT ROOFS .....	5
SECTION 1.d REPAIR OPTIONS.....	5
SECTION 1.e SELECTING A CONTRACTOR .....	6
CONCLUSION .....	7
SECTION 2 SELECTING ROOFING PROFESSIONALS.....	8
SECTION 2.a WHY CHOOSE A PROFESSIONAL ROOFING CONTRACTOR? .....	8
SECTION 2.b ROOFING CONTRACTORS ASSOCIATION OF BRITISH COLUMBIA .....	10
SECTION 3 ROOF GUARANTEES & WARRANTIES.....	12
SECTION 3.a RGC GUARANTEE PROGRAM DESCRIPTION .....	12
SECTION 3.b A REVIEW OF THE RCABC GUARANTEE CORP. (RGC) GUARANTEE CERTIFICATES, MAINTENANCE BONDS, AND CONTRACTORS' GUARANTEES .....	15
SECTION 4 ROOF MATERIAL INSTALLATION .....	20
SECTION 4.a ASPHALT SHINGLES.....	20
SECTION 4.b CEDAR SHAKES AND SHINGLES .....	39
SECTION 4.c CONCRETE AND CLAY TILES.....	50
SECTION 4.d ARCHITECTURAL METAL ROOFING .....	68
SECTION 4.e METAL ROOFING TILES .....	94
SECTION 4.f BUILT-UP ROOFING (BUR/TAR & GRAVEL) .....	94
SECTION 4.g MODIFIED BITUMINOUS MEMBRANES (TORCH ON).....	100
SECTION 4.h MEMBRANE ROOFING NON-BITUMINOUS .....	105
SECTION 5 ROOF MAINTENANCE .....	115
SECTION 5.a THE IMPORTANCE OF ROOF MAINTENANCE .....	115
SECTION 5.b CEDAR RESTORATION .....	117
SECTION 5.c MOSS AND ALGAE CONTROL .....	118
SECTION 6 TECHNICAL INFORMATION.....	120
SECTION 6.a ROOF DECKS .....	120
SECTION 6.b VAPOUR RETARDERS.....	125
SECTION 6.c ROOF DECK INSULATION .....	128
SECTION 6.d VENTILATION.....	136
SECTION 6.e METHODS FOR GRANULE LOSS REPAIRS .....	139
SECTION 6.f RIDGING AND WRINKLING OF MODIFIED BITUMEN ROOF MEMBRANES.....	141

# SECTION 1

## CONSUMER GUIDE TO ROOFING

The information provided in this publication from the Roofing Contractors Association of British Columbia (RCABC) was compiled as a guide to assist consumers with the selection of roofing services in British Columbia.

This roofing guide includes information sections reprinted from the RCABC Guarantee Corp. (RGC) Roofing Practices Manual (RPM) and other publications including those used by the RCABC Educational Foundation (REF) during the training of roofing apprentices and journey persons for the province of British Columbia.

### SECTION 1.a CONSUMER TIPS ON BUYING A ROOF

#### **PURPOSE**

This article is intended as an overview to assist in the process of buying a new roof. An overview of basic information is provided to help you make informed decisions with regard to roof types, materials, inspectors and contractors. It is not intended as a “how-to” roofing guide to enable the homeowner to act as a contractor or roofing inspector.

#### **TYPES OF ROOFS**

Aesthetics may be the most significant aspect determining the type of roof for your home. The roof is a large and often highly visible surface and can affect the overall look of the building. What you like has the greatest impact on your choice. Neighborhood covenants may also determine the type of roofing material.

#### **Slope**

The slope of the roof is another significant factor. There are limits of application for most materials depending on how steep your roof is. If a roof has a 5:12 slope, for every 12” of horizontal run, there is a vertical rise of 5”. On roofs with low slopes, like 3:12, some materials do not perform adequately to shed water, so they may not be recommended or may even be disallowed for that slope.

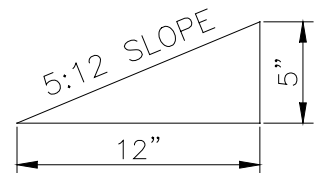

#### **Pitched (Water-Shedding)**

**Low-Slope** – Most materials designed for water-shedding roofs are designed for slopes above 4:12. There are fewer options when the roof slope approaches 2:12. Cedar is available down to 4:12 for shakes and 3:12 for shingles. Asphalt shingles can be applied as low as 2:12; however below 4:12 a superior underlay is required.

**Steep Pitch** – It is difficult to safely walk on a roof when the slope is steeper than 7:12. Application is more difficult and therefore more complicated and expensive. There is a wide variety of material for steep roofs.

## **Flat (Waterproof)**

Flat roofs are not as common as pitched roofs in residential roofing. The methods and materials are similar to those used for commercial roofing. Proper application requires a contractor with special training and experience to apply commercial types of roofs.

## **SECTION 1.b CHOOSING THE RIGHT MATERIAL FOR STEEP ROOFS**

One good way to determine the type of roof to buy is life cycle costing; comparing the cost of the roof with the life expectancy of the material, to calculate the annual cost.

Roofing materials have a fire rating to determine their permissible application. According to the 2006 BC Building Code, high-occupancy buildings (noncombustible construction, i.e.: apartments, condos, public buildings) require Class A, B or C (Article 3.1.5.3) fire-resistance (the highest rating), residential single-family dwelling for most applications has no such requirement (Sentence 9.10.8.1.(1)).

### **ASPHALT SHINGLES**

Asphalt shingles are the most popular choice in North America for water-shedding roofs. They are relatively inexpensive, easily applied and durable in all weather conditions. There are two basic types: organic and fiberglass. Both of these types are available in a variety of styles such as tab and laminate.

**Tab** – Tab shingles are the kind most people recognize with their familiar tabs and slots. Although the three-tab style is most common, some manufacturers produce a five-tab shingle. They are very versatile since they can be used on a roof slope as low as 2:12 when special application methods are applied.

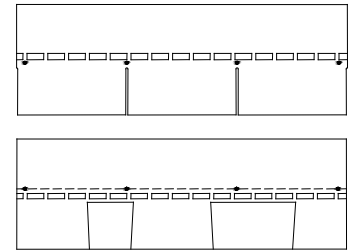

**Laminate** – Laminate shingles (also known as architectural shingles). They do not have slots and tabs but rather have a strip adhered (laminated) onto the base shingle giving it a textured appearance. They come in a variety of patterns and colors.

### **CEDAR**

Cedar comes in two basic forms: shingles and shakes. The basic differences are that shingles are sawn, shakes are generally split. Shingles are 3 ply and shakes are a 2 ply application. Cedar can be installed over solid sheathing, like plywood, but is better installed over spaced sheathing as it provides better drying. Shakes can be applied as low as 4:12, but shingles can go down to 3:12 with a reduced exposure.

**Grade** – Cedar is graded to meet specific standards by designated cedar grading authorities. No. 2 Grade is the minimum accepted by the building code for shingles; however, some guarantees require No. 1 Grade to minimize warping, dishing and splitting as the wood ages. Shakes are required to be a minimum No.1 grade. Both must be certified by a Standards Council of Canada accredited agency

**Treatments** – Cedar is prone to decay since it is an organic material, particularly when it is close to overhanging trees and vegetation. There are, however, anti-fungal treatments available to help it resist fungal decay. Cedar is essentially a good fuel and has no fire rating, but if it is treated with fire retardant, it can achieve a Class B or C fire rating.

## **METAL**

There are a variety of metals used for roofing but not all are acceptable. The seams of softer metals (i.e.: aluminum) weaken in time from the stresses of wind uplift resistance and the freeze/thaw cycle. Metal is not the cheapest material but it is becoming more popular due to its long life expectancy. Copper is popular for its unique metallic color upon installation and its classic green color after years of oxidation; however, it is generally out of reach for most homeowners due to high cost. Zinc, the metal alloyed with iron to produce galvanized steel, is extremely rust resistant and a very good roofing choice, however it's extremely high cost makes it an unrealistic choice for residential roofing. Pre-finished steel (galvanized steel with a heavy protective coating) has become very popular, as it is very strong, dependable and lightweight. It is available in many colors and used for the manufacture of both tiles and panels. An underlay is essential beneath any metal roofing due to condensation, which regularly occurs on the underside of the panel.

**METAL TILE** – They are designed to look like clay tile, cedar shakes, slate or even asphalt shingles though they also have some unique patterns. Application is similar to cedar, using battens or strapping for fastening.

**METAL PANEL** – There are several types of panels available. The one commonly used in residential roofing is a wide panel – 750 mm to 900 mm (30" – 36") – applied with exposed fasteners; screws with neoprene washers. The challenge with this type is that as the panel expands and contracts from the changing temperature, it puts stress on the fasteners and elongates the holes in the panel. After a few years the neoprene washer may break down and each screw hole becomes a potential leak. The alternative is a standing seam metal panel. The panels are narrower, between 300 mm and 500 mm (12" and 20"), and are attached with hidden fasteners. Each successive panel is seamed to the previous one. Standing seam panels are very reliable system used extensively for commercial applications but gaining popularity in the residential market. Additionally a snap-lock panel is available that does not require seaming.

**Slope** – The minimum recommended slope for metal tiles is 4:12; standing seam paneling however can be applied as low as 2:12 with a self adhered modified bitumen underlayment.

## **CLAY/CONCRETE TILE**

Concrete and clay have a natural tendency to absorb moisture, although manufacturing techniques have been used to prevent the moisture from passing through the tiles. Be sure the structure is capable of supporting the extra weight of concrete or clay roofing systems.

**Slope** – The minimum recommended slope for clay and concrete tiles is 4:12.

**Weight** – Concrete tiles are widely used in residential roofing, however the weight can be an issue for older buildings.

**CLAY** – One of the oldest roofing systems, available in many styles. The tiles were originally baked in the sun, but are now produced using kilns. Clay tile is ideally suited to hot, dry climates, where protection from the sun is the primary function and the freeze/thaw cycle is not an issue. Due to the porosity (water-absorption) of clay, some are graded (i.e., grade 1, 2 or 3, grade 1 being the most resistant) for resistance to "frost action". B.C. has a high frequency of thermal cycling so if clay is being considered, nothing less than grade 1 would be advised.

**CONCRETE** – Concrete tiles have been used as a roof covering in BC for many years. They are generally more expensive than asphalt shingles and more labor intensive because they are installed on battens over a plywood deck.



**SLATE**

Slate is a very expensive roofing material with dwindling numbers of skilled applicators. It is available in western Canada; however its use is limited. Slate is well suited to brick and masonry buildings designed to last hundreds of years and support tons of dead load. The lifespan of slate can be estimated in centuries (longer than the expected lifespan of wood-frame buildings) with failure often attributed to the corrosion of the metal fasteners used to attach them. Depending on the thickness of tile, slate adds between 0.3 – 3.9 kPa (7 to 80 lb/ft<sup>2</sup>) of dead load to the roof. Asphalt shingles add 0.1 – 0.15 kPa (2 – 3 lb/ft<sup>2</sup>).

**Slope** – The minimum recommended slope for slate tiles is 4:12.

**SECTION 1.c CHOOSING THE RIGHT MATERIAL FOR LOW SLOPE/FLAT ROOFS**

Flat roofs are generally not highly visible from the curb, so the appearance of a flat roofing membrane is not usually a governing factor. Therefore, the choice of a system is often based on cost and service life. A more expensive membrane may be a better choice if it has a correspondingly greater life expectancy.

**BUR** – BUR (Built Up Roof), also known as tar (asphalt) and gravel, is generally considered the original flat roof system. It was typically made of asphalt and organic felt in at least 4 offset layers, and then ballasted with gravel for wind uplift resistance, U.V., fire and live load protection (snow and rain). Newer re-enforcement felts for built up roofs are manufactured using fiberglass and polyester fabric, which is then saturated with asphalt.

**FLEXIBLE MEMBRANE** – Most flat roof systems other than BUR fall into the category of flexible membrane. They generally have better resistance to the stresses brought on by the expansion and contraction of thermal cycling. They also have longer life expectancy because they are manufactured using inorganic materials.

**MODIFIED BITUMEN** – A 2-ply membrane using asphalt modified with rubber (SBS) or plastic (APP) and man-made fabric (fiberglass or polyester) rather than organic based felt. It is competitive with a BUR system with much better performance. The base ply can be adhered with asphalt or adhesive, self-adhered, mechanically attached or torch applied. The cap sheet (similar in composition to the base sheet with a coating of colored ceramic granules on the top surface) is usually applied using a torch, welding it to the base sheet.

**EPDM** – (Ethylene Propylene Diene Monomer) EPDM is a single-ply rubber membrane, usually fully adhered or ballasted with gravel and often used residentially for hidden gutters and commercially for large warehouses. Cost is comparable to modified bitumen for smaller buildings. Seaming is accomplished using adhesive or uncured EPDM tape.

**TPO** – (Thermopolyolefin) Single-ply weldable reinforced plastic membrane usually fully adhered or mechanically attached. Seams are welded using hot air for a reliable permanent seal.

**SECTION 1.d REPAIR OPTIONS****ROOF REPAIRS/ REPLACEMENT**

Roofing materials have an estimated life span. Age alone though, is not necessarily the best way to decide what is required. Some roofs last longer than estimated and some fail prematurely due to a combination of reasons. Weather (rain, wind, hail, snow, heat, freeze/thaw cycle), debris, UV light and foot traffic (walking) all have a detrimental effect. If the material is still within its serviceable range,

repairs may be possible to extend the useful life of the existing roofing. At some point however, a complete replacement will be necessary.

**Condition** – An inspection by a qualified roofing contractor or roof inspector/consultant is the best way to determine the condition of your roof. Roof inspectors/consultants will charge for their services, but generally the result will be an unbiased assessment. There is a list of member roofing contractor firms and independent inspectors on the Internet at the homepage of the Roofing Contractors Association of British Columbia (RCABC) [www.rcabc.org](http://www.rcabc.org).

**Expense** – Intent or purpose for the building is another factor involved in the decision. If you intend to stay in a house until after retirement, re-roofing using a long life material such as steel panel would be reasonable. However if you intend to sell soon, it may be more cost-effective to have a good, but less expensive roof installed, or even to repair the roof if possible.

## SECTION 1.e SELECTING A CONTRACTOR

Homeowners may be tempted to hire a “friend of a friend”. However well meaning the friend is, the homeowner may be left with a roof of unknown installation quality and no recourse in case of accident or future problems. What to look for - Is it a licensed company? How long has it been in business? Is the contractor experienced with your roofing material? A fixed address (an office), telephone (not just a cell phone), liability insurance (in case there’s a problem during the roofing), WCB coverage (you can obtain verification online at [www.worksafebc.com](http://www.worksafebc.com) by clicking on “Obtain a clearance letter”, then fill out the form after clicking “Get a Clearance Letter”), trained employees (apprenticeship and manufacturer’s training programs) and ethics (they show up when they say they will) are all indicators of a company with integrity.

### **WHERE TO FIND ONE**

**Trade Association** – The best place to look for a contractor is by contacting the trade association representing that occupation (e.g. RCABC). Associations promote the trade and elevate its standards. The homeowner benefits from the ethical code adopted by the members, and can depend upon members’ accountability for performance on the job. Refer to “List of Roofing Professionals” in Table of Contents.

**RCABC** – RCABC has been dedicated to improving roofing standards and educating roofers since 1958. Since 1993, the RCABC Educational Foundation (REF) has been training roofers in the apprenticeship program in conjunction with the provincial government. The RCABC Guarantee Corp. (RGC) offers home and business owners’ a third party guarantee using approved products supplied by bonded manufacturers and applied by bonded member contractors. The result is a choice of quality, ethical roofing contractors whom you can rely on to apply roofing to the highest standard, often exceeding that of the manufacturers.

**Telephone Directory** – The yellow pages list most of the contractors in your area but do not assess their capabilities, experience or training. You may find that some listed in the yellow pages are no longer in business, an indication of how quickly businesses can come and go in the roofing industry.

**BBB** – The Better Business Bureau keeps a record of complaints made against contractors and if the matters were resolved or left unresolved. They generally do not get involved in the mediation process. The BBB does not record the qualifications of the contractor, the years in business or work ethic.

### **WARRANTY and GUARANTEE**

**Contractor’s Guarantee Length** – The length of contractors’ guarantees varies. Sometimes they offer extended guarantee periods to make an estimate more appealing, however it is presumptuous and

unrealistic to offer 10, 15 or 20 year and especially lifetime guarantees. The issue then becomes not whether the material will last that long, but whether the contractor will. Any guarantee is only as good as the company or person offering it. If the company providing the guarantee goes out of business next year, your guarantee goes with it.

**Manufacturer's Warranty** – Manufacturers usually only guarantee material since they are not responsible for the application. Providing the contractor follows their application specification, they will take responsibility for the performance of their material. For asphalt shingles the warranty period is generally the number associated with the shingle. A 25-year shingle would have a 25-year warranty period (usually pro-rated).

**Third Party** - A contractor or manufacturer may be biased when you file a warranty claim, since they have something to lose: time, money or both. There may be an additional cost associated with a third party guarantee; however the advantage is similar to buying insurance. A third party guarantee, available from RCABC, is like having an agent lobbying on your behalf in the event that you have a leak during the term of the guarantee. The leak is repaired at no cost to the homeowner.

For additional information, see "Roof Guarantees and Warranties" in Table of Contents.

### **UNDERSTANDING THE CONTRACT**

**Specification** – A specification (spec) is a detailed description of the materials, the execution of the work and any other particulars required to accomplish the project efficiently. The advantage to having a spec is that nothing is left to chance and everything is clear and upfront. They are more common for commercial jobs than they are for residential, however there is certainly nothing wrong with having a spec developed for a residential job. A roof consultant can produce one for your house according to its needs. If you choose to go directly to the contractor, he can produce a spec, which is usually part of the contract.

**Estimates** – Never be content to get just one estimate. For whatever reason, estimates can vary greatly from one contractor to another. As always, the lowest estimate is not always the best choice. Weigh it against the section "Selecting a Contractor" to help make your decision. A general rule is to get a minimum of 3 estimates. Make sure you are getting estimates on the same type of roofing systems so that you are comparing "apples to apples".

**Contract** – The contract is a legal document when you sign it. It should be clear and understandable, and include the details of the spec. If there are any pre-payment (deposit) clauses, they should be included in the contract, not brought up after the signing. It should include the responsibilities of both parties; the contractor – a general description of the work included; the homeowner – his financial obligations or payment schedule. It may also include the contractor's warranty description. If not, there should be some certificate clearly stating the terms of the warranty, provided upon completion.

### **CONCLUSION**

Roofing your house can be a large investment. It may take a little of your time to research it using articles like this, but it can save you money and headaches. RCABC is dedicated to providing good roofing by training roofers and offering a guarantee, which has proved reliable coverage since 1958. If you do not have the technical expertise to determine whether or not you are getting a good deal, it is highly recommended to use professionals for your project. If it seems costly to have your house re-roofed, it will be much more expensive to have it re-roofed due to a poor installation. Independent consultants, professional roofing contractors with trained employees and certainly RCABC can help guide you through the process.



## SECTION 2

# SELECTING ROOFING PROFESSIONALS

The following lists of roofing professionals and information articles were compiled to assist consumers with the selection of Professionals who provide a variety of roofing services in British Columbia.

Note that the Professional Roof Inspection/Consulting Firms listed are not members of the RCABC but are Independent Companies who are Accepted to perform inspections under the RGC Guarantee Program.

---

### SECTION 2.a WHY CHOOSE A PROFESSIONAL ROOFING CONTRACTOR?

A professional is generally recognized as a person who has specialized knowledge of, and has received intensive training in, a particular field. Interestingly enough, another common way of determining that people are professionals is by contrasting them with amateurs. And that is exactly what we would like to talk to you about. Roofing technology has changed markedly in the last ten years. New roof coverings, insulation materials and innovative application techniques demand the education and expertise of a professional!

You should know that roofing is a relatively "easy-entry" business. Frankly, not all roofing contractors are professionals, and too many home and building owners have paid dearly for using amateurs. A mere glance through the yellow pages will show that there are dozens - maybe hundreds - of people calling themselves roofing contractors.

A year-to-year comparison of the yellow pages will show you that many contractors do not stay in the business for very long. But when you are considering a roof for your own home or building, you do not want to hire someone who has just "hung out a shingle" but has no expertise in the field. You want to work with a pro...someone who will deliver an effective, long lasting roof and stand behind the job.

Roofing is a complicated and demanding trade. A professional roofing contractor must have knowledge of materials and building technology as well as a trained and skilled work force to give the best possible service to his customers.

Because an informed customer is a good customer, find out as much as you can about the contractor you are considering. To get the job done right the first time, and to avoid costly repairs later, insist on a professional. Insist on a member of RCABC!

Professional roofing contractors may have large or small businesses. They may run a union shop or may be non-union. They may have been in business 50 years (some of our members have been!), or just a few. But they all have some traits in common.

#### **PROFESSIONAL ROOFING CONTRACTORS ARE:**

##### **Well Established...**

A professional roofing contractor will have a permanent place of business, a telephone number, a tax identification number and a business licence.

**Experienced and Knowledgeable...**

The contractor should be an experienced problem solver, with a thorough understanding of his industry. Roofing skills cannot be learned overnight. There are accepted methods for roofing around pipes, vents, chimneys and rooftop equipment. Often, roofing materials are incompatible and can cause problems if applied by an amateur.

**Committed to Education...**

The roofing industry offers a variety of educational programs that a professional roofing contractor will have attended. More importantly, the best roofing contractor is only as good as the workers who actually install your roof. Insist on having trained, experienced roofing applicators with trade qualifications instead of labourers employed for one or two interim jobs.

**Insured and Committed to Safety...**

Roofing is a dangerous business. A sloppy operation can endanger the workers and bystanders and cause property damage. Do not hesitate asking the contractor for proof of the insurance he carries. Beware of the low bidder who is cheap because he does not have complete insurance, including worker compensation (WCB) coverage. Too many unsuspecting home and building owners have been dragged into litigation involving uninsured contractors.

**PROFESSIONAL ROOFING CONTRACTORS ALSO:****Use Quality Materials...**

In today's market, you can buy dozens of different types of roofs. A professional roofing contractor will help you make the best decision for your building and for your budget, using quality materials produced by reputable manufacturers.

**Stand Behind Their Work...**

A roof is a big investment and, for optimum performance, it should be regularly inspected and maintained. Ask your professional roofer about an ongoing maintenance program.

A professional roofing contractor is interested in more than simply getting the job done and moving on. He will offer service after the sale and application. He will offer a five-year Guarantee Program jointly underwritten by the contractor and RGC, written in a language you can understand.

**What Can You Do To Make Sure You Are Working With A Professional?**

Be Sure You Are Comfortable with the contractor and the roof system he is suggesting. A pro is going to be happy to answer your questions.

Check Customer References. Ask for the names of several customers with roofs similar to yours. Call them. Be sure the contractor has performed as promised.

Check Financial Information. A professional roofing contractor will give you the names of creditors and banking references. Make sure the roofing contractor is a responsible businessperson.

Call the Better Business Bureau. You will find out quickly if there have been a lot of complaints about the contractor, or if any complaints have not been satisfactorily resolved.

Insist on A Written Proposal. You will get it from a professional roofing contractor. Examine it to make sure you think it is complete and fair.

Insist on Membership in the Roofing Contractors Association of B.C. This trade association of professional roofing contractors monitors its members' performances, assists in disputes involving owners and members, and guarantees its members' work if an RGC Guarantee Certificate is requested.

How to Find One? Ask friends and neighbours who have had roofing work done about their experiences with contractors; ask the contractors for bids on your job; or call RCABC at 604-882-9734. Visit our website [www.rcabc.org](http://www.rcabc.org) for email contact information. We will give you the names of roofing contractors in your area. Home and building owners should base their decisions on the qualities they deem most important in a roofing contractor.

---

## **SECTION 2.b ROOFING CONTRACTORS ASSOCIATION OF BRITISH COLUMBIA**

The ROOFING CONTRACTORS ASSOCIATION OF BRITISH COLUMBIA (RCABC) is the representative industry authority for the professional roofing contractors in British Columbia, and is the provincial affiliate of the CANADIAN ROOFING CONTRACTORS ASSOCIATION (CRCA).

The Association deals with standards of roofing practices and material acceptances; the issuance of joint contractor/association guarantees; membership criteria; discipline, ethics, and professional development of its members; advising the public, specifying authorities and governments on the proper use of roofing contracting services; and promoting and protecting the public's and the members' interests.

RCABC is funded by dues received from its Active Members (professional roofing contractors) and its Associate Members (manufacturers and suppliers). RCABC has also enjoyed the financial support of the Canada Employment and Immigration Commission (CEIC), the National Research Council (NRC), and the British Columbia Ministry of Advanced Education and Job Training.

### **RCABC Members Code of Ethics**

A membership requirement of the Roofing Contractors Association of British Columbia is the obligation to conduct corporate business activity and to encourage and support Association action which will promote the advancement of the roofing industry, the welfare of members, their employees and the Association and, in the final analysis, the provision of quality work.

Members of the Roofing Contractors Association of British Columbia are therefore committed to:

1. Co-operating with general contractors and other trades in providing the best quality of work in conformance with applicable Canadian laws and accepted standards of business ethics;
2. Abiding by the Association Constitution and By-Laws;
3. being aware of Association policies with respect to specification standards, established tolerances, and competitive practices; and the assumption of contractor liability in their moral best interests as contractors, in those of their competitors and in those of the Association and the purchasers of roof application service;
4. Employing and utilizing only highly skilled and technically qualified trades persons, and refraining from raiding competitors' work forces.
5. Refraining from competitive practices, which would have the effect of influencing for or against union or non-union contractors.
6. Respecting the principles, rules and procedures of Bid Depositories, where these are in effect.
7. Recognizing the role of design and specifying authorities and cooperating with them in the fullest sense, provided that professional and quality standards are not compromised.
8. Recognizing the role of material and other suppliers and their relationships with roofing contractors, design and specifying authorities and purchasers of roofing application service; and ensuring that the relationships are productive and non-compromising.

9. Recognizing the need for the welfare of members' employees, including their occupational health and safety and the adoption of policy and action to ensure this.
10. Co-operating with one another so that membership in RCABC is seen by others as being synonymous with conducting business on the basis of accuracy, truth, integrity, and good faith.
11. As competition is fundamental to the free enterprise system, the main and underlying principle of this code is ethical competitive practice. Membership in the Roofing Contractors Association of British Columbia recognizes and requires a pledge to observe this principle.

## SECTION 3

# ROOF GUARANTEES & WARRANTIES

The information provided in this publication from the Roofing Contractors Association of British Columbia (RCABC) was compiled as a guide to assist consumers with roofing guarantees and warranties provided for roofing services in British Columbia.

This roofing guide includes information sections reprinted from the RCABC Guarantee Corp. (RGC) Roofing Practices Manual (RPM) and other publications including those used by the RCABC in the province of British Columbia.

---

### SECTION 3.a RGC GUARANTEE PROGRAM DESCRIPTION

#### Five-Year and Ten-Year Programs

#### Specification Guidelines - Inspections - Guarantees

The objective of the Roofing Contractors Association of B.C. Guarantee Corp. (RGC) Guarantee Programs are to provide to the building owner the assurance of quality materials installed to specific standards by a professional roofing/waterproofing contractor and backed by the RCABC Guarantee Corp. (RGC).

Initiated in 1960, RGC offers a roofing industry Guarantee Program that is backed by both the contractor and RCABC. The program is based on accepted RCABC standards, materials and guidelines that require inspections of the roofing application by independent, accepted roofing inspection firms. RCABC is proud to have been the initiator of the first Roofing Association backed guarantees in Canada, covering BOTH workmanship AND materials.

In 1977 RCABC introduced the first Association backed Five Year Standard Guarantee and in 1998 RCABC Guarantee Corp. (RGC) initiated a Five Year Residential Guarantee to offer homeowners (Single family residences) guarantee coverage under the program. Guarantee periods cover a five-year term and are co-signed jointly by the roofing contractor and RGC. Under the RGC Standard Five Year Guarantee the roofing contractor is responsible for any claims for the first two-year period. In addition the roofing system is re-inspected after two years and, if necessary, brought up to acceptable standards by the roofing contractor prior to RGC assuming responsibility for the final three years, under the guarantee program. Under the Residential Five Year Guarantee the contractor is responsible for claims for all five years.

RCABC Guarantee Corp. (RGC) officially launched the RGC Ten (10) Year Extended Guarantee on January 1st 2005. Under the Ten (10) Year Extended Guarantee the roofing contractor is responsible for any claims for the first two-year period and RGC for the remaining eight years. Roof inspections for the Ten (10) Year Extended Guarantee are performed by an independent inspection firm on a daily basis, whenever possible, while roofing is in progress. Two-year reinspections are the same for the Ten (10) Year Extended Guarantee as the required for the Five (5) Year Standard Guarantee. In addition, the Ten (10) Year Extended Guarantee features two maintenance inspections during years five (5) and eight (8) by an independent roof inspector, typically from the same inspection firm that completed the original roof application inspections.

The RGC Five (5) Year Waterproofing Guarantee introduced by RCABC Guarantee Corp. (RGC) program in 2009 provides coverage for waterproofing systems on plazas, promenades and terraces. Inspections for a Five (5) Year Waterproofing Guarantee are performed by an RGC accepted

independent inspection firm on a daily basis (whenever possible) while waterproofing membrane installations are in progress. In addition, a membrane moisture survey (scan) report that confirms the water tight integrity of the waterproofing membrane system is required by a firm specifically accepted by RGC prior to installation of any overburden (other than adhered protection boards or membranes). Under the Five Year Waterproofing Guarantee the contractor is responsible for any claims for the first two-year period. The waterproofing system is re-scanned after two years and, if necessary, brought up to acceptable standards by the RCABC contractor prior to RGC assuming responsibility for the final three years under the guarantee program.

RGC Guarantee Standards and Accepted Materials listed in the Roofing Practices Manual (RPM) apply to the Five (5) Year Standard, Ten (10) Year Extended and Five (5) year RGC Waterproofing Guarantee plus Five Year Residential Guarantee Programs.

As an added protection to the owner, the RGC Guarantees provides that in all cases, where during the term of the Guarantee the roofing/waterproofing contractor is no longer active in the business, RGC assumes the full responsibility for the Guarantee underwritten.

The inspections required under the RGC Guarantee Program are as follows:

#### **RGC Five Year Guarantee**

- Inspections based on one inspection for every 30 squares during the
- actual roofing application, typically starting with a deck surface inspection.
- Final inspection upon completion.
- Written report by independent inspection company.
- Roofing System Record presented to owner.
- A re-inspection two years following completion.
- Written report presented to owner.

#### **RGC Ten Year Extended Guarantee**

- Inspections based on daily, whenever possible, during the actual roofing application, typically starting with a deck surface inspection.
- Final inspection upon completion.
- Written report by independent inspection company.
- Roofing System Record presented to owner.
- A re-inspection two years following completion.
- Written report presented to owner.
- A five (5) year roof maintenance inspection.
- Written report presented to owner.
- An eight (8) year roof maintenance inspection.
- Written report presented to owner.



### **RGC Five Year Waterproofing Guarantee (Plaza, Promenade and Terraces)**

- Inspections based on daily, whenever possible, during the actual waterproofing membrane Installation, typically starting with a deck surface inspection.
- Deck surface inspections which include moisture content report by the waterproofing applicator (contractor) on all concrete decks, performed daily prior to waterproofing installations.
- Membrane Moisture Survey report confirming watertight integrity of membrane prior to installation of any over burden. (with the exception of adhered protection boards)
- Final inspection upon completion.
- Written report by independent inspection company.
- Waterproofing System Record presented to owner.
- An Electronic Scan two years following completion.

### **RGC Residential Five Year Guarantee**

*Note:* The RGC Residential Five-Year Guarantee only provides for a random final inspection on one in four roofs installed under this form of Guarantee.

At the completion of each roofing project, the owner of the building is provided with a "Roofing System Record" that contains:

- the five year Guarantee Certificate,
- all roofing inspection reports,
- a roof plan detailing penetrations and protrusions (when available),
- pictures where necessary, and
- A Roof Maintenance Guide.

Architects and other specifying authorities refer to the RGC "Guarantee Standards" and guidelines issued in the RGC Roofing Practices Manual (RPM), which has become THE standard reference manual in British Columbia on roofing applications for owners and specifying authorities alike.

The main features of the RGC Guarantee Program are:

- that Guarantee Standards are established by the RGC, to which all members must adhere in order to receive the Guarantee, the RGC guidelines are under constant review in order to provide updates and advice to members, owners and specifying authorities,
- The Guarantee Program requires mandatory inspections by an independent inspection firm, who must remain independent by dealing at arm's length with the roofing contractor, the material supplier and the owner.

*Note:* RGC Five Year Residential Guarantee only provides for random final inspection on one in four roofs installed under the Residential Program.

- Specifying authorities and/or owners ARE INVITED to preselect an independent inspection firm from the RGC list of acceptable inspection firms. Owners ARE ENCOURAGED to negotiate their own inspection rates and pay the independent inspection firm directly, the Guarantee issued is backed not only by the individual roofing contractor but also by the RGC as well,
- The Guarantee covers BOTH workmanship AND materials for RGC accepted materials and roof systems. This combination of coverage is not available from any other source.

We are confident that our program provides the best assurance to owners that the roof they buy will offer long and trouble-free performance. Our confidence is substantiated by the fact that the large majority of design authorities in the Province support our program and demand the RGC Guarantee in their specifications; a Guarantee Program offered only by member contractors of RCABC.

Independent Inspections required under the RGC Guarantee Program must be conducted by an inspector acceptable to RGC who is employed by one of the accepted INDEPENDENT inspection firms active in British Columbia. A current listing can be found on [www.rcabc.org](http://www.rcabc.org) under the 'Accepted Inspection Firms' icon.

RCABC supports the Western Canadian Chapter of the Roof Consultants Institute (RCI) [www.rci-online.org](http://www.rci-online.org) in its goal of educating and skill-testing roofing inspectors. Applicants for Independent Inspector are required to inform RGC as to their membership status in RCI when submitting their application for acceptance.

### **Material Acceptance**

RGC Guarantees covers BOTH workmanship AND materials for accepted materials.

The benefit to the building owner is obvious – No longer will his roof leak be bounced back and forth between a roofing applicator and material supplier, each pointing to the other as the cause of the problem.

The RGC Guarantee Certificate covers both. It is the RGC, which will determine financial responsibility of the roofing contractor and the material supplier AFTER having ensured that the leak is fixed, pursuant to the Guarantee.

Manufacturers and/or suppliers who wish to have their products covered by the RGC Guarantee Program are required to submit a detailed application.

The materials listed are those which have been accepted by RGC upon application by the manufacturer/supplier to RGC in compliance with RGC policy A-041 and for which RGC Guarantee Certificates are available.

The acceptance of these materials in no way reflects on the quality or performance of other materials not listed.

---

## **SECTION 3.b A REVIEW OF THE RCABC GUARANTEE CORP. (RGC) GUARANTEE CERTIFICATES, MAINTENANCE BONDS, AND CONTRACTORS' GUARANTEES**

An overview has been prepared by the Roofing Contractors Association of BC in order to clarify some of the common misconceptions among owners, specifiers and contractors about the "equivalency" of Maintenance Bonds, Contractors' Guarantees and the RCABC Guarantee Corp. (RGC) Guarantee Certificate.

RCABC Members are encouraged to discuss this paper with building owners and specifying authorities. For more detailed legal and technical aspects, readers will have to refer to their professional advisors.

### **Observation:**

Specifiers frequently request a "5 /10 Year RCABC Guarantee for Workmanship and Materials" or "equivalent coverage by a Bond."

## **Is there really an equivalent to the RGC Guarantee Certificate?**

Let us review the facts:

### **What is a Performance and/or Maintenance Bond?**

A Bond is NOT insurance, NOT a warranty, NOT a third party guarantee comparable to the RGC Guarantee Certificate.

Whereas a Performance Bond terminated with the completion of a contract, a Maintenance Bond, like the RGC Guarantee Certificate commences at this juncture. An analogy would be the basic medical coverage purchased by all citizens with the prudent provider adding extended health benefits. Similarly, the RGC Guarantee Certificate is an excellent protection to follow the term of a Performance Bond, even if such Bond included a common one-year maintenance period.

### **What terms are available for Maintenance Bonds?**

They typically cover one year; frequently two years; or, only under very exceptional circumstances, more than two years, and the "2+2+1" year term acceptable to some specifiers is never acceptable to a surety. In any case, any initial extension past two years (which would never be granted after the expiration of the bonding term) may be granted exclusively at the discretion of the surety, and never on demand of the specifier.

RCABC has yet to see a successive two-year Bond and is not aware of any surety firm having issued a five-year term on any roofing job!

Now...

### **How does this compare to the RGC Guarantee Certificate?**

The RGC Guarantee Program has been built, since 1958, on a progressively strengthened foundation:

Coverage extending past the term of a two-year Bond, to five years.

Qualified applicators...RCABC offers ongoing training and upgrading programs for its members at the first Roofing Institute of its kind in North America dedicated to training for the roofing industry.

Compliance with the RCAB Code of Ethics, covering such provisions as unprofessional conduct (a member could be under review by RCABC before an owner would even be aware of any problem). Failure to comply with the Code of Ethics has resulted in termination of members. RCABC is proud of its record in self-policing.

Independent Inspections during the roof application, by accepted inspectors, preferably selected by the owner from a list of RGC accepted inspectors.

Adherence to RCABC Guarantee Standards, which are in addition to, and a lot more detailed than, most job specifications.

Accepted materials ... manufacturers undergo a detailed review of their experience and qualification and have to provide legal undertakings before acceptance.

A true third party guarantee which may be called upon regardless of the relationship of the roofer to the owner and which is valid even if the contractor/supplier has gone out of business.

Coverage of both workmanship and materials pursuant to the wording of the RGC Guarantee Certificate.

100% coverage of contract value, RGC's guarantee is NOT prorated, unlike some manufacturers' warranties.

A two-year reinspection under the five-year guarantee term and the correction, initiated by RGC, of any valid deficiencies.

RCABC will assist in the problem resolution process to avoid the trouble and expense of reference to the judicial system. RCABC is the oldest Roofing Trade Association in Canada and has established an enviable track record in the industry.

### **What terms are offered by RGC?**

Five year and ten year Guarantee Certificates are offered. The major limitation on guarantees is the requirement for positive slope on all new construction projects (it is RGC's way of encouraging design authorities to follow common sense: "water shed from a roof cannot possibly penetrate the membrane and contribute to a leak!")

### **What is the track record of Maintenance Bonds?**

You may wish to ask any of the independent roofing consultants about their actual experiences with sureties, who actually prefer not to write Maintenance Bonds.

According to the course outline "Surety Bonds, Course 45" published by the Insurance Institute of Canada, a most disturbing current trend is the substantial attention being paid to the scope of Bond forms by senior bureaucrats in the public works sectors.

They observe that the motivation seems to be adversative and critical of surety companies' past performance, which is adjudged as unsatisfactory.

It goes on to say that many public officials appear frustrated and angered by the careful and often slow process used by a surety company to settle a default.

### **How does this compare to RGC's track record?**

You may want to ask the many private and public building owners who, after filing a valid claim with RGC, have received their fair rewards for putting their trust in the RGC Guarantee Certificate.

Statistically speaking, during a period of five years, RGC received 162 claims, of which 127 or 78% were found to be valid. RGC expended \$140,000.00 to correct deficiencies (not including other amounts which were the responsibility of various members). Against a volume of 3000 jobs, this represents a claim rate of only 4%; but what if your job was one of those valid claims and did not hold an RGC Guarantee Certificate?

Although RGC is unable to track the expenses incurred by our member contractors and manufacturers, we know that their additional expenses for valid claims have been substantial. Many claims were "expedited" by RCABC's influence on its members.

### **How about filing a claim?**

The process under either a Bond or the RGC Guarantee Program is fairly similar.

The claimant must file a written claim within a stipulated time period of noticing the non-performance or deficiency/leak and the surety or RGC then initiates corrective measures.

However, under a Bond, it is the owner alone who must demand the action and, in case of a dispute, the surety stands behind the contractor to resolve the dispute – the surety does NOT step in to resolve it for the parties involved.

Worst of all, if a dispute arises between the contractor and the surety, the dispute needs to be resolved before any claim by an owner will be addressed.

Surety firms also require that all other avenues be exhausted first: the responsibilities of the general contractor, subcontractor, manufacturer, distributor/supplier – all rate a higher priority than the Bond without voiding its indemnities.

Compare that situation to RGC where, under the five year Guarantee, RGC actually looks for problems at the two-year reinspection stage. Valid deficiencies identified at that point are corrected at the initiation of RGC. Often the owner is not even aware of any deficiencies!

Loss prevention is RGC's major goal: first, by attempting to prevent a problem from arising and, secondly, by ensuring that the owner's valid interests are looked after, should the preventative measures fail.

### **And what if the owner experiences a valid claim?**

RGC offers a simplified process for filing the claim:

For the first two years of an RGC five or ten year Guarantee Certificate, the owner deals directly with the roofing contractor (with copies of any correspondence to RGC).

After two years, the owner deals directly with RGC.

In either case, RGC will involve the manufacturer as required. However, regardless of whether or not RGC recovers costs from the manufacturer, the first item of priority is resolving a valid claim. RGC will ensure expeditious resolution of such a claim, frequently within days of it being received.

### **What about the cost for a bond?**

The surety charges only a service fee for providing 50% or 100% Bond (of contract value). If a surety incurs a loss under a Bond, it expects to recover from the guarantor. Accordingly, a surety must be very careful not to prejudice its rights or guarantees. A claimant could become quite frustrated trying to collect on a claim.

Example of a contract requiring a Performance Bond followed by a two year Maintenance Bond:

At \$5.50 per thousand, the fee for a \$50,000 contract will be \$275 for a 50% Bond; or, at \$8.00 per thousand, the fee will be \$400 for a 100% Bond.

Example for a Maintenance Bond, but without a preceding Performance Bond:

At \$10.00 per thousand per annum, the service fee for the sample contract of \$50,000 will be \$500.00 per annum for a 100% Bond (50% Bonds are not common in these circumstance), or \$1,000.00 for a two year period.

### **What about the cost of the RGC Guarantee?**

An RGC Guarantee Certificate covering 100% of the \$50,000 contract value would cost \$1,000 for a five-year term (a separate Maintenance Bond will cost this amount for a two year term), plus the inspection fees levied by the independent inspection firm (preferably selected and paid for by the owner from the list of RGC Accepted Inspectors).

In return, the owner obtains not only a true third-party guarantee for workmanship and materials, but also independent inspections, a two-year reinspection, service by RCABC members in good standing, RGC Accepted Materials on their roof, one contact in case of any problems, and free assistance with resolving problems – all backed by the resources of RCABC and its contractor members and accepted material manufacturers located throughout the Province of British Columbia. A good deal indeed!

RGC's track record is based on approximately 100,000 roofing squares (10'x10' area) per year being applied with an RGC Guarantee Certificate (with an annual contract value of more than \$90,000,000).

**And what about Contractor Guarantees?**

While surety firms assign a ceiling for any contractor on the amount of bonding outstanding at any one time – often limiting the ability of a contractor to bid while waiting for other tenders to be awarded – many contractors opt to issue a “company guarantee”, most frequently consisting of just found words: “guaranteed for ‘X’ years”.

Whenever the Contractor’s Guarantee exceeds five years, the bonding firm will reduce his bonding ceiling. And, if a bonding company is worried enough to reduce a contractor’s ceiling, why would any owner want to accept less than a surety, who, after all is not in business to incur financial losses.

**What is the Contractor’s Guarantee?**

Any owner who has had their legal advisor comment on these found words has received the shock of his life! Furthermore, the longer the term, the more likely that the owner will not be able to locate the contractor when a problem does arise!

RGC Guarantee Certificate is backed by the oldest Roofing Contractors Association in Canada (incorporated in 1958), which is also the most progressive association in the industry. RCABC offers services to the public as well as to association members that are simply second to none.

We appreciate your support of RGC. We know it is justified! We suggest that you specify only the RGC Guarantee Certificate for your roof.

RCABC, representing the Professionals in the roofing industry, is committed to being FIRST among trade associations.



## SECTION 4

# ROOF MATERIAL INSTALLATION

The information provided in this publication from the Roofing Contractors Association of British Columbia (RCABC) was compiled as a guide to assist consumers with the selection of roofing services in British Columbia.

The following information was compiled to assist consumers with the choices of reliable roofing materials available in British Columbia.

This roofing guide includes information sections reprinted from the RCABC Guarantee Corp. (RGC) Roofing Practices Manual (RPM) and other publications including those used by the RCABC Educational Foundation (REF) during the training of roofing apprentices and journey persons for the province of British Columbia.

---

### SECTION 4.a ASPHALT SHINGLES

Asphalt shingles are probably the most widely used system for steep sloped roofing, especially in the residential market. Asphalt shingles must comply with CSA A123.1-98 for organic based shingles, and CSA A123.51998 for fiberglass core. Most asphalt shingles manufactured today have a fiberglass core.

The felt is saturated with refined asphaltic flux (obtained from the distillation of petroleum products). The saturated felt is then coated on both sides with an asphaltic coating, which may be compounded with a water-insoluble mineral stabilizer (an inorganic material, such as limestone). The top weathering surface is coated with mineral granules and the unexposed surfaces coated with a fine mineral-parting agent.

#### MATERIALS

Asphalt shingles are available in a variety of weights & colours, and in the following types:

**Strip Shingles** – are generally rectangular, may have square or irregular butts, and may be divided into tabs (by slits or cut-outs) to vary their appearance. Manufacturers sometimes laminate variously shaped pieces of similar material or extra layers of granules and coating to the weathering surface to enhance the shingles' appearance. (Refer to Laminate below).

**Laminate** – Laminate shingles (also known as architectural shingles) do not have slots and tabs but rather have an additional strip of shingle adhered (laminated) onto the base shingle and often have blended granules giving both depth and a textured appearance. They come in a variety of patterns and colours.

**Self-Seal Shingles** – are made with strips or spots of adhesive laminated to the top surface which, under certain conditions, (usually prolonged sunlight/heat); will adhere to the underside of the butts of the next overlying course. Proper adhesion will not take place if the adhesive is too cold or damp, or if it has become oxidized or covered by dust or other foreign matter. Consideration should be given at the time of application as to whether the adhesive will be effective or whether the shingle tabs should be secured by other means. CSA requires that "shingles incorporating factory-applied adhesive sealant (self-sealing shingles) shall meet the requirements of ANSI/ASTM D3161, Wind-Resistance of Asphalt Shingles".

**STANDARD OR STEEP SLOPE APPLICATION****1:3 (4" in 12") or steeper**

This specification is intended to meet or exceed the requirements of the Building Code and shall be installed to CAN3-A123.51-M85 (R2006) Asphalt Shingle Application on Roofs 1:3 and steeper.

**MATERIALS**

**Asphalt Shingles** – manufactured to CAN/CSA-A123.1-98 (R2004) for organic felt shingles or CAN/CSA-A123.5-98 (R2004) for fibreglass felt shingles.

**Nails** – large-head corrosion resistant roofing nails conforming to CSA B111; electro-galvanized, hot-dipped galvanized steel, aluminum, or stainless steel.

**Sheet Metal** – minimum 0.56 mm (26 gauge) galvanized iron, 0.80 mm (0.032") aluminum, or 0.56 mm (0.0216", 16 oz) copper.

**Roofing Cement** – asphalt-base conforming to CGSB 37-GP-5Ma.

**Eave Protection** self-adhesive, rubberized asphalt sheet material (see Accepted Materials List of the RGC Roofing Practices Manual); or one ply No. 50 asphalt coated roofing sheet CSA A123.2 M1979; or one ply No.30 non-perforated felt conforming to CSA A123.3-M (when allowed by Municipal requirements); or two plies No.15 perforated asphalt-saturated felt conforming to CSA A123.3 M1979, cemented together with lap cement.

**Valley Materials** – sheet metal and/or minimum 3.7 mm thick SBS granulated modified bituminous membrane conforming to CAN/CGSB 37-GP-56M.

**Lap cement** conforming to CGSB 37-GP 4M.

**Underlayment** – A minimum of No. 15 non-perforated asphalt saturated felt conforming to CSA A123.3 M1979 and/or ASTM D226-95 or manufacturer and RGC accepted eave protection or manufacturer and RGC accepted proprietary underlayment (see Tab 3.15).

**Water diverter Flashing** – Minimum 0.56 mm (26 gauge) galvanized iron, 0.80 mm (0.032") aluminum, or 0.56 mm (0.0216", 16 oz) copper.

**Cladding Screws** – Minimum No. 8 ( $\frac{1}{8}$ ") with rubber gasket grommet or washer made of metal compatible and corresponding in colour to metal flashing material.

**APPLICATION**

Asphalt Shingles shall be installed to CAN3-A123.51-M85 (R2006) Asphalt Shingle Application on Roofs 1:3 and steeper.

**Deck Requirements**

Wood decks shall be constructed of plywood, securely fastened to supports. Oriented strand or non-veneer panels are not recommended as acceptable deck materials.

Plywood for roof decks shall conform, as a minimum, to the requirements of the Building Code; but it is strongly recommended, for better nailing and less deflection, that the following be used: 12.7 mm ( $\frac{1}{2}$ ") thick when supported at 400 mm (16") o/c or 15.9 mm ( $\frac{5}{8}$ ") thick when supported at 600 mm (24") o/c (refer to RGC Guarantee Standards - A2.4 Wood Decks).

Knotholes and cracks in decks shall be considered defects and must be covered with sheet metal nailed in place.

Wood decks constructed of shiplap and dimensional lumber shall be overlain with sheathing that conforms to CSA 0151-04, Canadian Softwood Plywood, Grade C or better; or CSA 0121-M 1978

(R2003) Douglas Fir Plywood, Grade C or better. Minimum thickness to be 9.5 mm ( $\frac{3}{8}$ "). Refer to 2.1.10 Wood deck overlay sheathing (Non-Structural) for sheathing overlay installation requirements.

Roof sheathing, for asphalt shingle applications, plywood or non-veneer (OSB or wafer) panels fastened to metal Z-bars (girts), must be a minimum thickness of 15.9 mm ( $\frac{5}{8}$ "). In addition, asphalt shingle roofing nails must not penetrate the roof sheathing when metal Z-bars (girts) are used as the attachment substrate for roof deck sheathing.

*Note:* For re-roofing over old deck, deck must comply to specifications as for new work (refer to RGC Guarantee Standards).

### **Eave Protection and Underlay**

Acceptable eave protection includes one continuous width of self-adhesive rubberized asphalt sheet; or one ply No. 50 Type S asphalt coated roofing sheet (or No.30 non-perforated felt when allowed by local Municipal requirements); or two plies No.15 perforated asphalt-saturated felt, cemented together with lap cement. Apply on the roof deck, extending from the edge of the roof a distance of 915 mm (3') up the roof slope to a line not less than 300 mm (12") inside the inner face of the exterior wall. Eave protection is not required over unheated garages, carports, and porches, or where the roof overhang exceeds 915 mm (3') measured along the roof slope from the edge of the roof to the inner face of the exterior wall. Eaves protection membrane is to be carried up all abutments (walls, skylights, etc.) a minimum of 125mm (5")

If roll roofing is used for eave protection, and more than one run is needed to provide coverage, head laps and end laps are to be a minimum of 100 mm (4") and must be fully cemented with lap cement.

Accepted eave protection membranes may also be used as underlayment.

Acceptable underlay is a minimum one ply No. 15 non-perforated asphalt saturated felt or manufacturer and RGC accepted eave protection (see Tab 3.15) or RGC and shingle manufacturer accepted underlayment. Apply to all roof decks in shingle fashion with sufficient nails to hold in place until shingling. Side laps are to be a minimum 50 mm (2") and end laps a minimum 150 mm (6"). To prevent wrinkling, let felt relax before installing. Underlay and asphalt shingles must be applied on the same day. Underlayment is to be carried up all abutments (walls, skylights, etc.) a minimum of 125mm (5").

### **Shingles**

**Strip or Standard Shingle - Minimum slope 1:3 (4" in 12")** –First course shall consist of shingles of the same type used for the roof applied with tabs facing up the slope when permitted by the manufacturer, use the starter assembly dictated by the manufacturers printed instructions. The shingles are to overhang the fascia sufficiently to lead the water into the eaves trough [normally 37 mm (1-1/2")]. Each shingle shall be applied with a minimum of four nails per shingle.

All shingles shall be applied with a maximum exposure as recommended by the manufacturer. All vertical and horizontal lines shall run true. Each shingle shall be sealed with a manufacturer's accepted asphalt adhesive sealing strip, or each tab shall be manually gum tabbed.

**Lock Shingles** – Minimum slope 1:3 (4" in 12") Starter course shall consist of an additional course of strip shingles, lock shingles, or Type M mineral surface, minimum width of 335 mm (13"). The shingles are to overhang the fascia sufficiently to lead the water into the eaves trough (normally 37 mm [1-1/2"]). Each shingle shall be applied with a minimum of two nails. All trimmed or partial shingles shall be hand gum-tabbed at terminations like gable edges, valleys, vents, curbs, etc.

**Laminated or Architectural Shingles** – Minimum slope 1:3 (4" in 12"). Starter course shall consist of Manufacturers' proprietary starter shingles or same type shingles with the exposed (bottom) portion cut off below the seal strip or cut to achieve sufficient head lap and applied to manufacturers' printed application instructions. Shingles are to overhang the fascia sufficiently to lead water to eaves trough

normally 37 mm (1½"). Each shingle shall be fastened with a minimum of four nails per shingle. Nails must penetrate through both layers of laminated shingle at overlap areas within the nail zone and high nailing is not an accepted practice for asphalt shingle application covered under the RGC Guarantee Programs

*Note:* All types of shingles shall be applied with a maximum exposure and minimum shingle course off sets as recommended by the manufacturers' written application instructions. All vertical and horizontal lines shall run true. Each non-locked shingle shall be sealed with a manufacturer's accepted asphalt adhesive sealing strip, or each tab shall be manually gum tabbed.

Shingles are to overhang the fascia sufficiently to lead water to eaves trough, nominally 37 mm (1½").

### Valleys

All valley types must have an accepted eaves protection membrane as underlayment.

**Open valleys** shall be flashed with not less than one layer of sheet metal not less than 600 mm (24") wide or one layer of 3.7 mm thick SBS, granulated, modified bituminous membrane, 1 m (39") wide centred in the valley and fastened with nails spaced not more than 450 mm (18") located 25 mm (1") away from the edges. Cut and trim all points of valley shingles. Open valleys are the only style permitted for lock type or laminated asphalt shingles.

### Optional Open Valley Application Method: Laminated Shingles

The vertical course open valley application method is acceptable for use only with laminated asphalt shingles and only when the asphalt shingle manufacturer recommends or accepts this optional open valley application method. Apply one row of shingles laid end to end vertically up each side of the installed valley materials with the shingle butt edge placed toward the centre of the valley, using chalk lines for guidance. Fasten shingles along manufacturers' fastener line with a minimum of four fasteners per shingle. Field shingles (uncut) are laid perpendicular to the roof slope over vertical shingles on both roof planes. Ensure that no nails are located any closer than 150 mm (6") from the butt edge of vertical shingles and that all edge joints between vertical shingles are completely covered or overlaid with field shingles. Shingle course offsets shall be applied as recommended by the manufacturers' written application instructions.

**Woven valley** (sometimes used for standard slope shingle application) shall consist of a minimum 915 mm (36") wide layer of not less than No.30 roofing felt, centred in the valley and nailed in such a manner to hold firmly in place until the shingles are applied. *Note:* Woven valleys are not acceptable when interlocking or laminated shingles are used.

Valley shingles are laid over the lining by either:

- applying them on both roof areas at the same time, weaving each course in turn over the valley; or
- covering each roof area first to a point approximately three feet from the centre of the valley and weaving the valley shingles in place later.

When following the first procedure, the first course is laid along the eaves of one roof area up to and over the valley, extending it along the adjoining roof area for a distance of at least 300 mm (12"). The first course is then laid along the eaves of the intersecting roof area and is extended over the valley on top of the previously applied shingle. Succeeding courses are then laid alternately, first along one roof area and then along the other, weaving the valley shingles over each other. Make sure that the shingles are pressed tightly into the valley and nailed in the normal manner, except that no nail is to be located closer than 150 mm (6") to the valley centre line, and that two nails are to be located as shown at the end of each terminal strip.

**Closed cut valleys** shall consist of a minimum 915 mm (36") wide layer of not less than No. 30 roofing felt centred in the valley without bridging and nailed to be held firmly in place until the shingles are applied. Closed cut valley may only be used on roof slopes exceeding 1:3 (4" in 12") and only if permitted in writing by the shingle manufacturer. Closed cut valley may not be used with inter-locking or laminated asphalt shingles.

The first course of shingles is laid along the eaves of one roof area up to and over the valley, extending it along the adjoining roof section for a distance of at least 300 mm (12"). Follow the same procedure when applying succeeding courses of shingles on this roof area. Make sure that the shingles are pressed tightly into the valley and nailed in the normal manner except that no nail is to be located closer than 150 mm (6") to the valley centreline and that two nails are to be located as shown at the end of each terminal strip.

Then apply the first course of shingles along the eaves of the intersecting roof area, extending it over previously applied shingles and parallel to the centre line of the valley. Cut and trim all points of valley shingles to prevent water from penetrating between the courses. Succeeding courses are applied and completed as indicated in Tab 7.1.5 "Application Details".

**Vertical Upstand Flashing** must be installed at all vertical intersections. When fasteners are required to secure exposed metal counter flashings only cladding screws, minimum No. 8 (1/8") with a rubber gasket grommet or washer, made of metal compatible and corresponding in colour to the metal flashing material are acceptable. Nails are not acceptable as exposed fasteners to secure exposed metal counter flashings.

Materials used must conform to Guarantee Standard A6.7, Sheet Metal Material Standards.

**Apron flashing** shall extend a minimum 125 mm (5") up vertical surfaces, 100 mm (4") over the roof material and 100 mm (4") around the corners. On areas that need more than one length of flashing e.g. adjacent walls, only standing seams or 'S' locks can be used to join pieces.

**Step flashing** shall extend a minimum 125 mm (5") up vertical surfaces, 100 mm (4") between courses of roofing and have a 75 mm (3") headlap. Step flashing shall extend a minimum 75 mm (3") beyond the down slope corners and be folded, but not cut. Step flashing shall be placed flush with the butt edge (bottom) of each asphalt shingle course. Fastening shall be a nail placed 50 mm (2") down from the top edge and 25 mm (1") in from the outside edge on the deck flange portion of each step flashing.

**Water diverter flashing** shall be installed at all roof eaves to direct water away from walls and into drainage systems. Diverters shall extend a minimum 125 mm (5") up vertical surfaces, 100 mm (4") over roof material and be installed on a 20-degree angle to the vertical slope.

**Backpan flashing** shall extend a minimum 150 mm (6") up vertical surfaces, 450 mm (18") up the slope and 100 mm (4") beyond the corners. Corners must be folded, but not cut. If the upstand is more than 750 mm (30") wide, a saddle is recommended. In lieu of a saddle, a backpan that extends a minimum of one-sixth the width of the upstand but not less than 150 mm (6") vertically and up the roof slope to a point equal in height but not less than 450 mm (18") must be used.

**Counter flashing** must be used to shed water from vertical surfaces to the flashings.

**Plastic vents** or vent flashing shall have a minimum 75 mm (3") flange for the roof material on the upslope side and a minimum 50 mm (2") flange for the roof material on all other sides. Plastic vents or vent flashing shall not be used for combustion or grease laden venting. Acceptable plastic vents or vent flashing must conform to CSA-A93-M82 (R1992), or ICBO #4159.

**Metal vents** or vent flashing shall have a minimum 100 mm (4") flange for the roof material on all sides and a minimum vertical sealed height of 75 mm (3"). All seams must be fully soldered or welded. Material used must conform to Guarantee Standard A6.7, Sheet metal Material Standards.

**Plumbing vent flashings** shall have a minimum 100 mm (4") flange on all sides. The flashing must allow for thermal movement of the vent pipe. Settle caps or storm collars must be used where possible. Acceptable plumbing vent flashings must conform to CSA B272-93.

### **Capping**

Ridge capping must be acceptable for use by the asphalt shingle manufacturer and must be of the same material as the shingles and must be applied to provide double coverage. Capping must be nailed in such a manner that nails are not exposed. Continuous ridge venting is also acceptable and is recommended for all areas with vaulted ceilings.

### **Guarantee**

The work may qualify for a five (5) or ten (10) year RGC Guarantee.

### **Ventilation – Attic Space/Cathedral/Insulated Roof Assemblies**

The attic or ceiling space must be adequately ventilated according to appropriate Building Code standards. The design and selection of the ventilation system is the responsibility of the design authority.

Cathedral ceiling and/or insulated roof assemblies must have a minimum space for unobstructed air movement of 63 mm (2.5"), between the roof sheathing and the insulation where joist spaces are not individually vented, the spaces must be cross-strapped with purlins that are not less than 38 mm (1-1/2") x 38 mm (1-1/2") installed on top of the roof joists.

*Note:* The BC Building Code Part 9 for Housing and Small Buildings, Section 9.19 Roof Spaces, 9.19.1.3 Clearances requires:

Not less than 63 mm (2.5") of space shall be provided between the top of the insulation and the underside of the roof sheathing.

Ceiling insulation shall be installed in a manner that will not restrict a free flow of air through roof vents or through any portion of the attic or roof space.

Asphalt shingles applied over insulation and shingles applied to sheathing over insulation without the appropriate air space are not permitted for this application in the Guarantee Program.

### **Special Nailing Requirement**

For slopes exceeding 1.75:1 (21" in 12") use 6 nails per shingle; 1 at each end and double nailed at each third point. Immediately upon installation, cement shingle tabs down with a spot of asphalt plastic cement approximately 22 mm in diameter, located at the centre of each tab. This may be exceeded by manufacturer's requirements.

### **Wood Deck Overlay Sheathing (Non-Structural)**

Non-Structural continuous sheathing overlay conversions installed over existing spaced sheathing (spaced strapping) and board (plank, mill, or shiplap) decks must conform to the following:

Overlay deck sheathing must conform to CSA 0151-04 Canadian Softwood Plywood, Grade C or better; or CSA 0121-M 1978 (R2003) Douglas Fir Plywood Grade C or better, minimum thickness 9.5 mm (3/8").

Direction of new sheathing may be either horizontal or vertical and joints are not required to be over supporting members, but are to be fully or intermittently supported by the strapping.

Spaces between strapping are to be filled in with additional strapping or new sheathing trimmed as necessary to provide edge support for the new overlay sheathing joints. Maximum allowable spacing of strapping is 200mm (8") between boards; all larger spaces are to be filled in with additional strapping.



Maximum nail spacing is to be 300 mm (12") o.c. fastened through existing strapping/boards into supporting members. Edges of new sheathing are to be nailed at a maximum of 150 mm (6") o.c. through strapping/boards and into supporting members as applicable. Nails for the new sheathing are to penetrate supporting members, (underlying trusses or rafters), a minimum of 19 mm (3/4").

End joints of new sheathing are to be staggered by a minimum of 400 mm (16") and spacing between sheathing is to be 2 mm (3/32") on all sides.

Metal drip edge flashing is to be installed at all eave and rake edges. Drip edge flashing is to extend to overlap existing fascia boards or wall cladding.

Clearance to all "hot" pipes to be as per BC Building Code, 2006 Edition.

## STANDARD OR STEEP SLOPE ASPHALT SHINGLE APPLICATION

Applicable to slopes 1:3 (4" in 12") and greater.

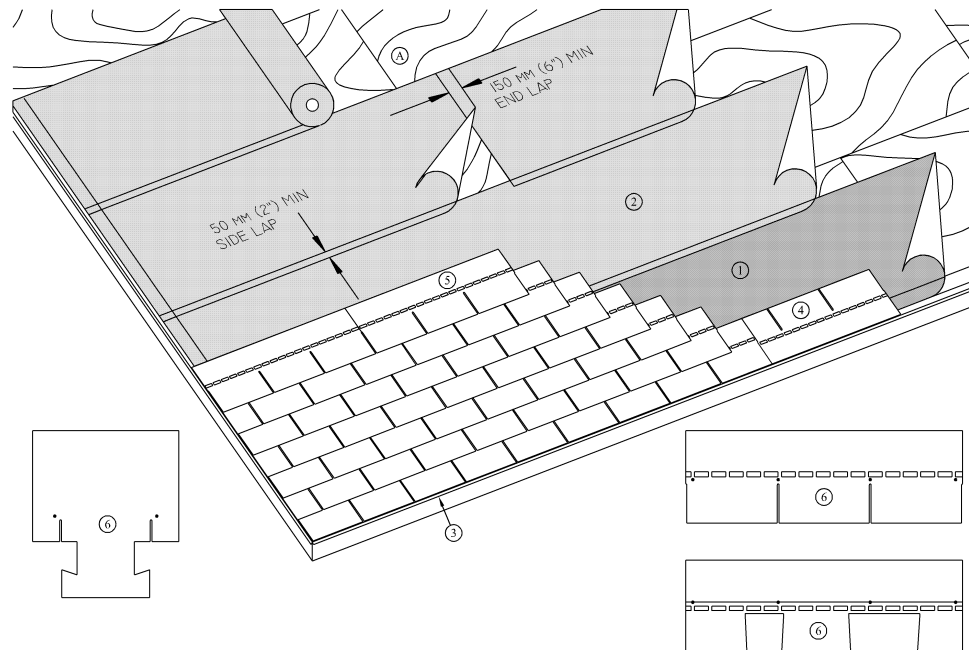

### WORK INCLUDED:

1. Eaves Protection: One ply of self-adhered modified bituminous underlayment material or other acceptable eaves protection (See Tab 7.1.2, Sentence 1.1.5). Lap 50 mm (2") minimum on sides and 150 mm (6") minimum on ends.
2. Underlayment: Minimum one ply of No. 15 non-perforated asphalt saturated felt or accepted eaves protection. Overlap 50 mm (2") minimum on side laps and 150 mm (6") minimum on end laps.
3. Edge Metal Flashing: Optional, installed to manufacturer's printed instructions.
4. Starter Course: Standard Strip and interlocking shingles starter course consist of same type shingles as for roof, applied tabs facing up the slope.
5. Laminated shingle starter courses consist of Manufacturers' proprietary starter shingles or same type shingle with the exposed (bottom) portion cut off below the seal strip. Apply to Manufacturers' printed application instructions.
6. Standard Strip, Laminated or Interlocking Shingles: Applied as recommended by manufacturer.
7. Nailing: *Note:* manufacturer's recommended nailing pattern. Placement varies with manufacturer.

### RELATED WORK BY OTHERS

- A. Acceptable Deck

**LOW SLOPE APPLICATION****1:6 (2" in 12") TO 1:3 (4" in 12")**

This specification is intended to meet or exceed the requirements of the Building Code.

**MATERIALS**

**Asphalt Shingles** – manufactured to CSA A123.1 98 for organic felt shingles or CSA-A123.5 98 for fibreglass felt shingles with a minimum mass of 34.3 kg (75.4 lb weight) per bundle. The shingle may be either organic felt or glass fibre, provided it is a single thickness strip type and approved for this construction by the manufacturer. (See tab 2.2 Accepted Materials.)

*Note:* Interlocking or laminated style asphalt shingles are not acceptable for low-slope applications.

**Nails** – large-head corrosion resistant roofing nails conforming to CSA B111; hot-dipped galvanized steel, aluminum, or stainless steel.

**Sheet Metal** – minimum 0.56 mm (26 gauge) galvanized iron, 0.80 mm (0.032") aluminum, or 0.56 mm (0.0216", 16 oz) copper.

**Valley Materials** – sheet metal to RGC Guarantee Standards (see above) or accepted modified bituminous membrane conforming to CGSB 37-GP-56M minimum thickness 3.5 mm at the selvage edge (see Accepted Materials List in tab 2.2 of the RGC Roofing Practices Manual) and appropriate building code requirements.

**Eave Protection** – minimum 1 mm self-adhesive rubberized asphalt sheet material (see Accepted Materials List in tab 2.2 of the RGC Roofing Practices Manual).

**Underlayment** – minimum 1 mm self-adhesive, rubberized asphalt sheet material (see Accepted Materials List in tab 2.2 of the RGC Roofing Practices Manual).

**Water diverter Flashing** – Minimum 0.56 mm (26 gauge) galvanized iron, 0.80 mm (0.032") aluminum, or 0.56 mm (0.0216", 16 oz) copper.

**Cladding Screws** – Minimum No. 8 ( $\frac{1}{8}$ ") with rubber gasket grommet or washer made of metal compatible and corresponding in colour to metal flashing material.

**APPLICATION****Deck Requirements**

[Minimum slope 1:6 (2" in 12")]

New wood decks and existing decks when re-roofing shall be constructed of plywood or OSB securely fastened to supports. Shiplap and dimensional lumber are not acceptable deck materials for this assembly.

Plywood or non-veneer panels for roof decks shall conform, as a minimum, to the requirements of the Building Code; but we strongly recommend, for better nailing and less deflection, that the following be used: plywood; 12.7 mm ( $\frac{1}{2}$ ") thick when supported at 400 mm (16") o/c or 15.9 mm ( $\frac{5}{8}$ ") thick when supported at 600 mm (24") o/c (refer to RGC Guarantee Standards).

Wood decks constructed of shiplap and dimensional lumber shall be overlain with sheathing that conforms to CSA 0151-04, Canadian Softwood Plywood, Grade C or better; or CSA 0121-M 1978 (R2003) Douglas Fir Plywood, Grade C or better. Minimum thickness to be 9.5 mm ( $\frac{3}{8}$ "). Refer to - Wood deck overlay sheathing (Non-Structural) - for sheathing overlay installation requirements.

Roof sheathing, for asphalt shingle applications, plywood or non-veneer (OSB or wafer) panels fastened to metal Z-bars (girts), must be a minimum thickness of 15.9 mm ( $\frac{5}{8}$ "). In addition, asphalt

shingle roofing nails must not penetrate the roof sheathing when metal Z-bars (girts) are used as the attachment substrate for roof deck sheathing.

*Note:* For re-roofing over old deck, deck must comply to specifications as for new work. (Refer to RGC Guarantee Standards).

### **Eave Protection/Underlay**

Provide an underlayment of self-adhesive rubberized asphalt sheet as listed in Tab 2.2 Accepted Materials over the entire deck, layered horizontally to the roof slope with a minimum headlap of 50 mm (2"), end lap 150 mm (6").

Underlay must be stripped in to all adjacent vertical surfaces, curbs, and penetration flashings. Stripping must be carried a minimum of 125 mm (5") up vertical surfaces and overlap a minimum 150 mm (6") onto the field areas.

### **Shingles**

Starter strip shall be shingles applied to the manufacturer's printed instructions

First course shall be applied with tabs overhanging fascia board sufficiently to lead water into eaves trough (normally 37 mm [1-1/2"]). Each shingle shall be applied with a minimum of four nails.

Each succeeding course shall be applied in a like manner with all vertical and horizontal lines running true or a random pattern as per the manufacturer's printed instructions. Exposure and nailing pattern must conform to the manufacturer's printed instructions.

Shingles must be sealed in a bed of compatible mastic at all gable edges and valleys.

### **Valleys**

Only Open Valleys are permitted for low-slope asphalt shingle roofing systems.

**Metal valleys** shall be flashed with not less than 600 mm (24") wide sheet metal as listed in tab 2.1.1 Edges of metal valleys must be fastened to the deck at 200 mm (8") o.c. and tied in to the underlay with a minimum 200mm (8") strip of self-adhered modified bitumen underlay material.

**Membrane valleys** must be not less than 1 metre (39.4") wide and a minimum 150 g/sq. m polyester or equal strength polyester-fibreglass reinforced granulated modified bitumen membrane roofing material with a minimum thickness of 3.5 mm at the selvage edge. Materials must be installed to the manufacturer's printed instructions.

Cut and trim all points of valley shingles.

### **Capping**

Ridge and hip capping must be acceptable for use by the asphalt shingle manufacturer and must be of the same material as the shingles and must be applied to provide double coverage. Capping must be nailed in such a manner that nails are not exposed except for the last cap, where exposed nails must be gummed.

### **Flashings**

Materials used must conform to Guarantee Standard A6.7, Sheet Metal Material Standards.

**Vertical Upstand Flashing:** must be installed at all vertical intersections. When fasteners are required to secure exposed metal counter flashings only cladding screws, minimum No. 8 (1/8") with a rubber gasket grommet or washer, made of metal compatible and corresponding in colour to the metal flashing material are acceptable. Nails are not acceptable as exposed fasteners to secure exposed metal counter flashings.

**Apron flashing** – shall extend a minimum 125 mm (5") up vertical surfaces, 100 mm (4") over the roof material and 100 mm (4") around the corners. On areas that need more than one length of flashing e.g. adjacent walls, only standing seams or 'S' locks can be used to join pieces.

**Step flashing** – shall extend a minimum 125 mm (5") up vertical surfaces, 100 mm (4") between courses of roofing and have a 75 mm (3") headlap. Step flashing shall extend a minimum 75 mm (3") beyond the down slope corners and be folded, but not cut. Step flashing shall be placed flush with the butt edge (bottom) of each asphalt shingle course. Fastening shall be a nail placed 50 mm (2") down from the top edge and 25 mm (1") in from the outside edge on the deck flange portion of each step flashing.

**Water diverter flashing** shall be installed at all roof eaves to direct water away from walls and into drainage systems. Diverters shall extend a minimum 125 mm (5") up vertical surfaces, 100 mm (4") over roof material and be installed on a 20-degree angle to the vertical slope.

**Backpan flashing** – shall extend a minimum 150 mm (6") up vertical surfaces, 450 mm (18") up the slope and 100 mm (4") beyond the corners. Corners must be folded, but not cut. If the upstand is more than 750 mm (30") wide, a saddle is recommended. In lieu of a saddle, a backpan that extends a minimum of one-sixth the width of the upstand but not less than 150 mm (6") vertically and up the roof slope to a point equal in height but not less than 450 mm (18") must be used. The leading edge of the flashing must be stripped in to the underlay.

**Counter flashing** – must be used to shed water from vertical surfaces to the flashings.

**Metal vents** – or vent flashing shall have a minimum 100 mm (4") flange for the roof material on all sides and a minimum vertical sealed height of 75 mm (3"). All seams must be fully soldered or welded. Material used must conform to Guarantee Standard A6.7, Sheet metal Material Standards. Flanges and succeeding courses of shingles must be set in a trowel coating of compatible mastic. The leading edge of the flashing must be stripped in to the underlay.

**Plumbing vent flashings** – shall have a minimum 100 mm (4") flange on all sides. The flashing must allow for thermal movement of the vent pipe. Settle caps or storm collars must be used where possible. Acceptable plumbing vent flashings must conform to CSA B272-93. Flanges and succeeding courses of shingles must be set in a trowel coating of compatible mastic. The leading edge of the flashing must be stripped in to the underlay.

### **Guarantee**

The work may qualify for a five (5) or ten (10) year RGC Guarantee.

### **Ventilation – Attic Space/Cathedral/Insulated Roof Assemblies**

The attic or ceiling space must be adequately ventilated according to appropriate Building Code standards. The design and selection of the ventilation system is the responsibility of the design authority.

Cathedral ceiling and/or insulated roof assemblies must have a minimum space for unobstructed air movement of 63 mm (2.5"), between the roof sheathing and the insulation where joist spaces are not individually vented, the spaces must be cross-strapped with purlins that are not less than 38 mm (1½") x 38 mm (1½") installed on top of the roof joists.

*Note:* The BC Building Code Part 9 for Housing and Small Buildings, Section 9.19 Roof Spaces, 9.19.1.3 Clearances requires:

1. Not less than 63 mm (2.5") of space shall be provided between the top of the insulation and the underside of the roof sheathing.

2. Ceiling insulation shall be installed in a manner that will not restrict a free flow of air through roof vents or through any portion of the attic or roof space.

Asphalt shingles applied over insulation and shingles applied to sheathing over insulation without the appropriate air space are not permitted for this application in the Guarantee Program.

### **Wood Deck Overlay Sheathing (Non-Structural)**

Non-Structural continuous sheathing overlay conversions installed over existing spaced sheathing (spaced strapping) and board (plank, mill, or shiplap) decks must conform to the following:

Overlay deck sheathing must conform to CSA 0151-04 Canadian Softwood Plywood, Grade C or better; or CSA 0121-M 1978 (R2003) Douglas Fir Plywood Grade C or better, minimum thickness 9.5mm ( $\frac{3}{8}$ ").

Direction of new sheathing may be either horizontal or vertical and joints are not required to be over supporting members, but are to be fully or intermittently supported by the strapping.

Spaces between strapping are to be filled in with additional strapping or new sheathing trimmed as necessary to provide edge support for the new overlay sheathing joints. Maximum allowable spacing of strapping is 200mm (8") between boards; all larger spaces are to be filled in with additional strapping.

Maximum nail spacing is to be 300 mm (12") o/c fastened through existing strapping/boards into supporting members. Edges of new sheathing are to be nailed at a maximum of 150 mm (6") o/c through strapping/boards and into supporting members as applicable. Nails for the new sheathing are to penetrate supporting members, (underlying trusses or rafters), a minimum of 19 mm ( $\frac{3}{4}$ ").

End joints of new sheathing are to be staggered by a minimum of 400 mm (16") and spacing of sheathing is to be 2 mm ( $\frac{3}{32}$ ") on all sides.

Metal drip edge flashing is to be installed at all eave and rake edges. Drip edge flashing is to extend to overlap existing fascia boards or wall cladding.

Clearance to all "hot" pipes to be as per BC Building Code, 2006 Edition.

## LOW SLOPE ASPHALT SHINGLE APPLICATION

Applicable to slopes 1:6 (2" in 12") and greater.

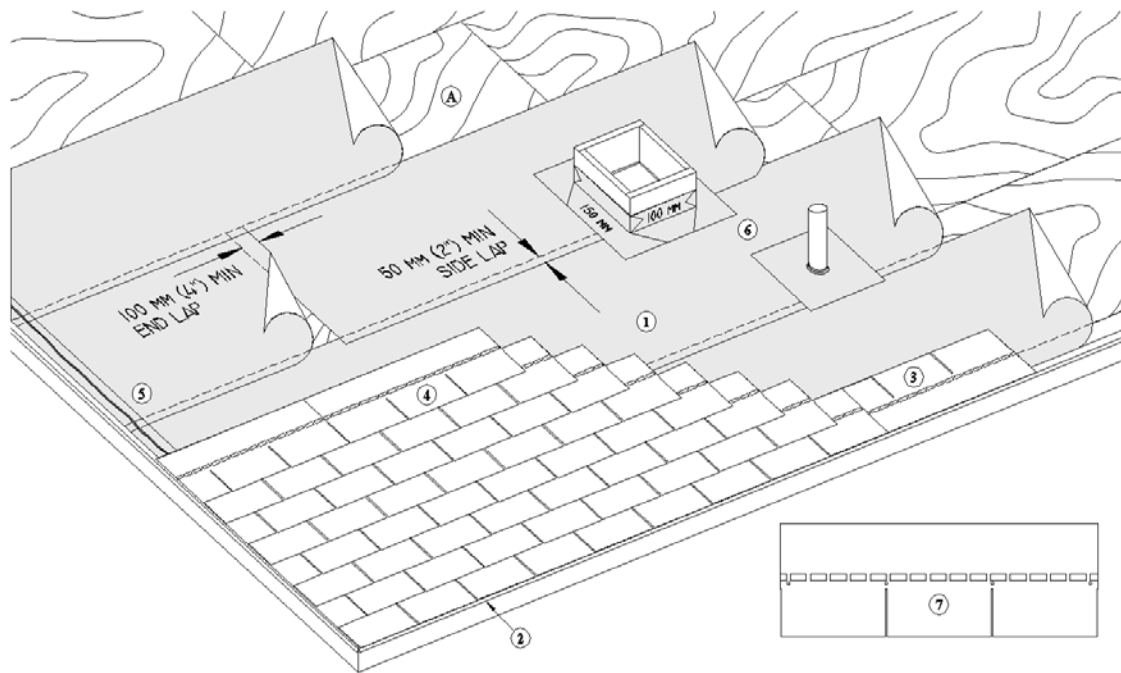

### WORK INCLUDED

1. Underlayment And Eave Protection: One ply of self-adhered modified bituminous underlayment material. Lap 50 mm (2") minimum on sides and 150 mm (6") minimum on ends.
2. Edge Metal Flashing: Optional, installed to manufacturer's printed instructions.
3. Starter Course: Consists of same type shingles used for roof, applied tabs facing up the slope.
4. Strip or Standard Shingles: Applied as recommended by manufacturer. Laminated shingles are not acceptable for this application.
5. Compatible Mastic: Heavy bead of compatible asphaltic mastic at rakes (gables) and valleys.
6. Protrusions: Curbs and skylights must be flashed with underlayment so as to shed water, with minimum 125mm (5") up vertical surfaces and 150 mm (6") lapping onto field surfaces. Vent stack underlayment flashing should fit tight to the vent pipe and be sealed with compatible mastic. For fire-rated stacks or hot pipe protrusions, strip in secondary metal deck flashing before installing rated stack/pipe flashing.
7. Nailing: *Note:* manufacturer's recommended nailing pattern. Placement varies with manufacturer.

### RELATED WORK BY OTHERS

- A. Acceptable Deck

## Asphalt Shingle Application Details

Open Valley

Closed Cut Valley

Woven Valley

Upper Junction Detail - Asphalt Shingle/Built-Up Roof

Lower Junction Detail - Asphalt Shingle/Built-Up Roof

Eave Detail - Standard or Steep Slope Roof

Chimney Flashing Detail – Orthographic

Typical Lead Vent Flashing

Counter Flashing – Diverter Flashings for Shingled Roof Systems

Integral Flashing – With Capillary Tab For Shingled Roof Systems

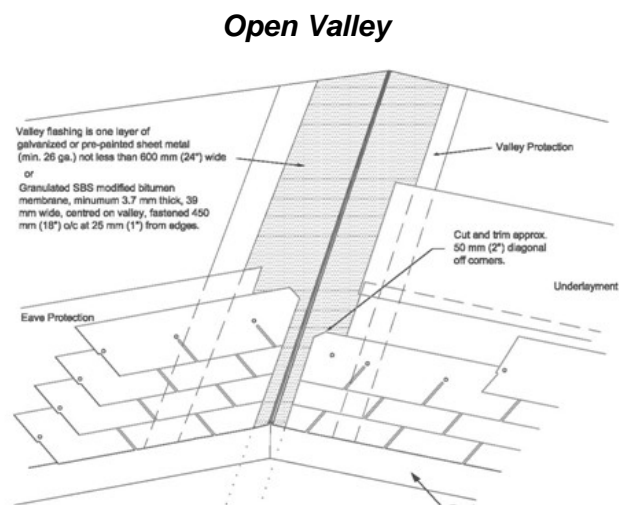



### Closed Cut Valley

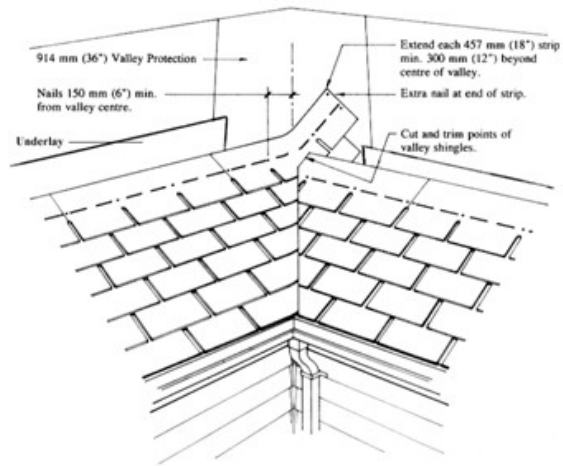

### Woven Valley

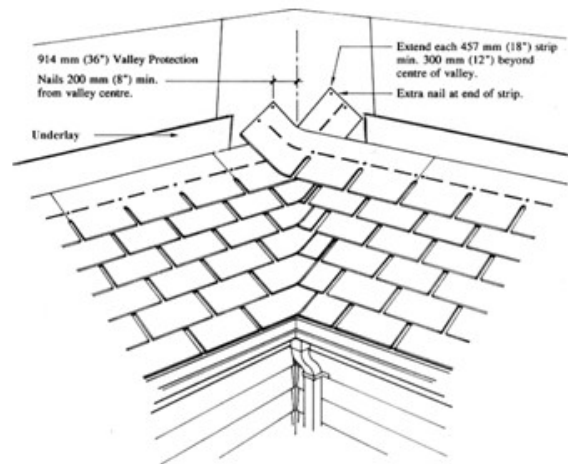

### Upper Junction Detail – Asphalt Shingle/Built-Up Roof

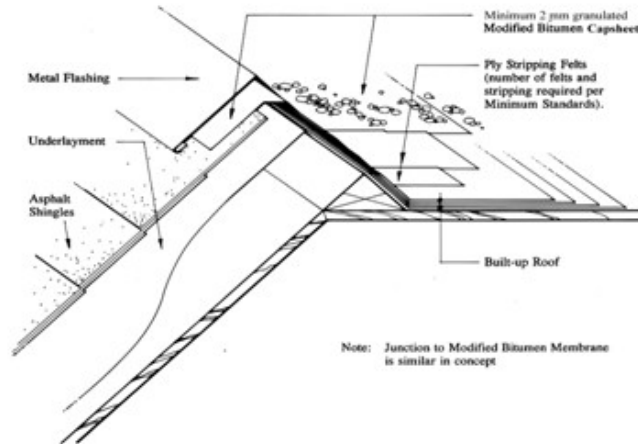

### Lower Junction Detail – Asphalt Shingle/Built-Up Roof

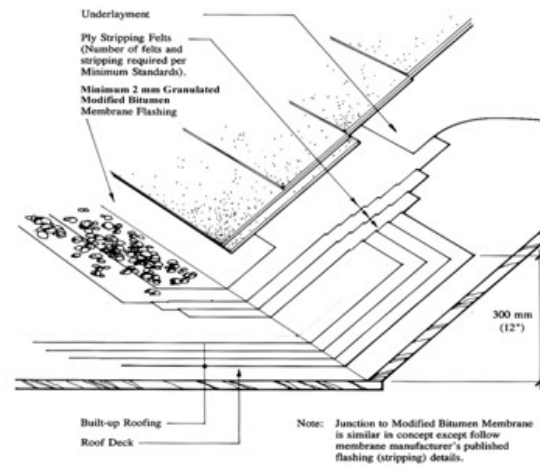

### Eave Detail – Standard or Steep Slope Roof

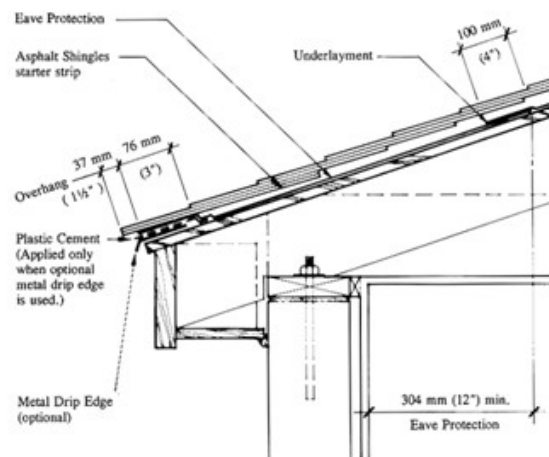

**Chimney Flashing Detail (Orthographic)**  
 (Slope of 1:3 (4" in 12") or Steeper)

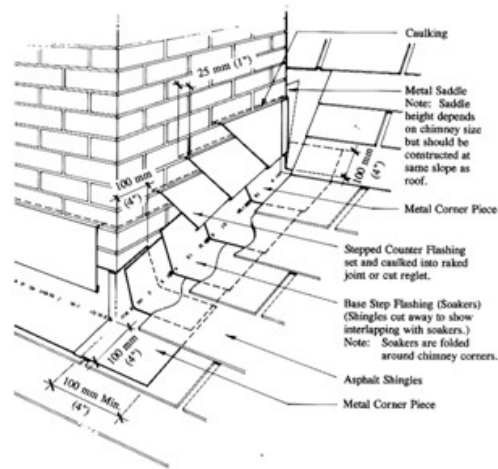

**Typical Lead Vent**

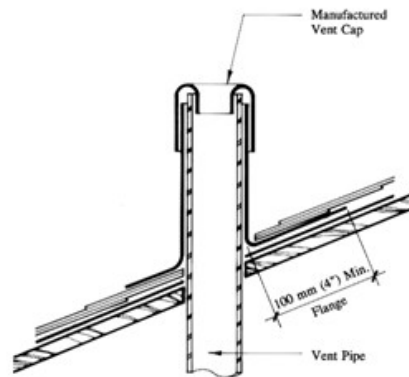

TYPICAL LEAD VENT

## COUNTER FLASHING – DIVERTER FLASHINGS FOR SHINGLED ROOF SYSTEMS

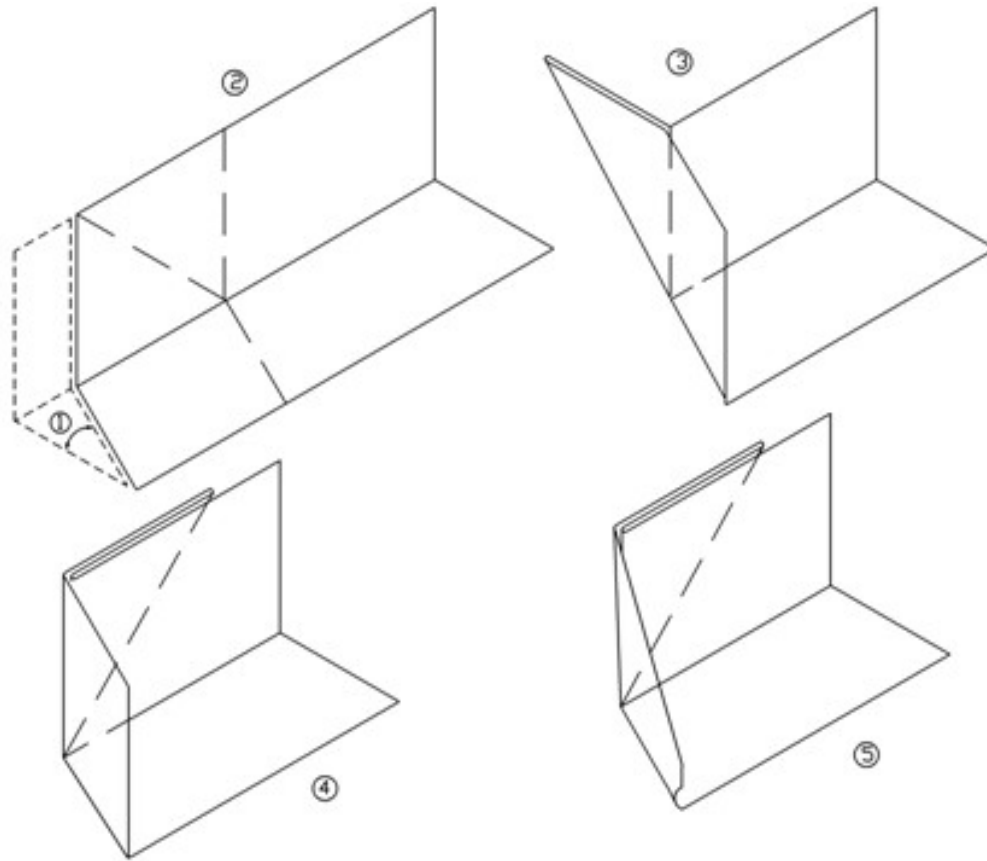

## WORK INCLUDED:

1. Trim: and the kick-out must be approximately 20-degree angle to the vertical slope.
2. Fold Layout: Formed from a minimum 26 gauge galvanized steel diverters shall extend a minimum 125 mm (5") up vertical surfaces 100 mm (4") to the roof.
3. Breadpanned Corner Fold: Fold up must be equal in height to the upstand of the flashing.
4. Hidden Seam: Breadpan fold to be turned behind the upstand.
5. Angle Trim: Kick-out can be angle trimmed and a drip edge formed at the outlet. Outlet is to extend a minimum of 25mm (1") lower than the edge of the roof material and lead water into the gutter where existing.

## INTEGRAL FLASHING – WITH CAPILLARY TAB FOR SHINGLED ROOF SYSTEMS

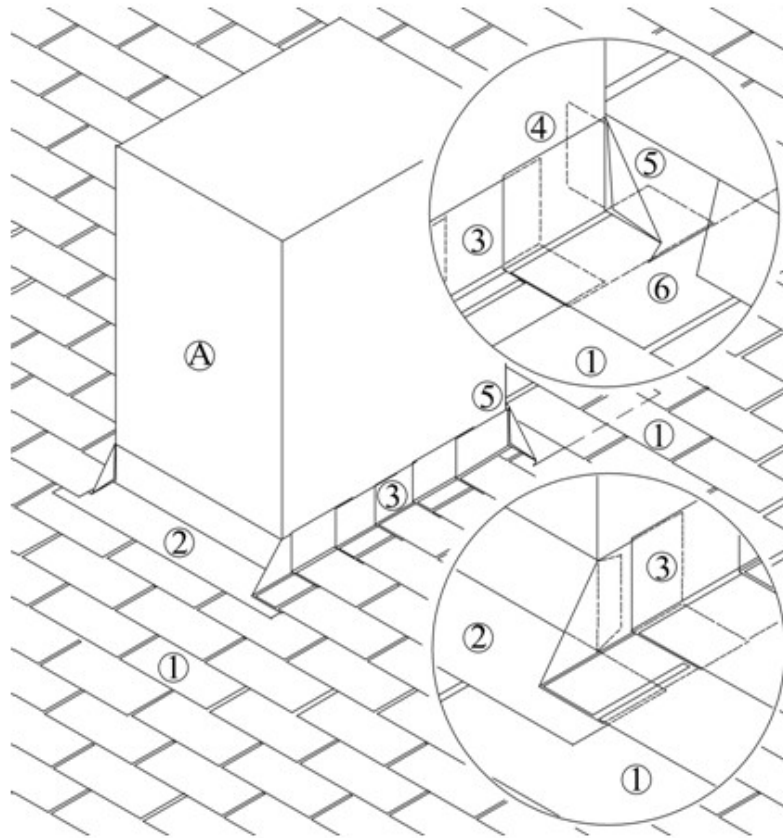

## WORK INCLUDED:

1. Asphalt Shingles: Installed to manufacturer's published instructions and RGC Guarantee Standards.
2. Apron Flashing: Extended a minimum 100mm (4") beyond corners, interwoven with shingles and step flashings.
3. Step flashings: Interwoven with each course of shingles, 75mm (3") head lap.
4. Final Step flashing: Extended around corner of the upstand and under back pan flashing. The upstand fold can alternatively be turned outward under the back pan fold.
5. Back Pan: The back-pan is to be extended 100mm (4") beyond the corner and folded. Apply caulking at the transition corner of the final step flashing and back pan.
6. Capillary Tab: A capillary tab is to be extended off the end of the back pan to lead water around the corner.

## SECTION 4.b CEDAR SHAKES AND SHINGLES

Western Red Cedar is appreciated worldwide for its rich, earthy colours, unique texture, and for its natural resistance to decay. Cedar has a fine, straight, and even grain, is free from pitch, and relatively strong. In addition, cedar has a low ratio of expansion and contraction with changes in moisture content and a relatively high impermeability to liquids. It is these attributes that make a properly milled, graded, and installed cedar shingle or shake a viable and attractive water-shedding roof.

### Materials

Cedar shingles are taper sawn with a relatively smooth face and back. They are installed in a three ply fashion and available in three lengths; 405 mm (16") "Fivex" or "XXXXX"; 455 mm (18") "Perfections"; or 610 mm (24") "Royals"; each length having uniform butt thicknesses. Four grades are available, with only one being acceptable under the RGC Guarantee Program:

No. 1 (Blue Label)

*Note:* No. 2 grade acceptable for starter course only.

Shingles are also available with "Fancy Butts" for aesthetic considerations.

Cedar shakes are split and/or sawn from a log along the natural grain of the wood and have a highly textured surface. They are normally available in two lengths, 455 mm (18") and 610 mm (24"). Roofing shakes are installed in a two-ply fashion and are available in four types:

Hand-split and Resawn Shakes: have split faces and sawn backs. The desired cut length of a log is split into "blanks". The blank is then run diagonally through a bandsaw to produce two tapered shakes.

Taper-split – produced by hand with a steel froe and mallet. A natural taper is achieved by reversing the block, end-for-end, with each split.

Straight-split – produced either by machine or by hand similar to taper-split except that, by splitting from the same end of the block, the shakes have the same thickness throughout.

Taper-sawn – are sawn on both faces to produce a relatively smooth finish

Quality control during the manufacture of cedar shakes and shingles for the RGC Guarantee program is audited by Standards Council of Canada accredited agencies. These agencies perform random unannounced inspections of the manufacturer's product to check that the grading is as stated on the label. Labels are issued by the grading agency to the manufacturer for identification of the type, grade, and origin of the product.

## CEDAR SHINGLE ROOFING APPLICATION

- This specification is intended to meet or exceed the requirements of the Building Code.
- Shingles shall be No. 1 Grade (only) conforming to CSA 0118.1-97 Cedar Shakes and Shingles (latest revision) and not less than 405 mm (16") long, and not less than 75 mm (3") but not more than 350 mm (14") wide, per Building Code requirement.
- Flashings shall be 0.56 mm (26 gauge) galvanized iron or 0.80 mm (0.032") aluminum.
- Underlayment shall be one ply No. 15 (asphalt saturated) roofing felt conforming to CSA A123-3-M1979.

## Roof Sheathing

Red cedar shingles may be applied over spaced sheathing or solid sheathing. When spaced sheathing is used, 19 mm x 89 mm (1" x 4") boards shall be spaced on centres equal to the weather exposure at which the shingles are laid.

## Roof Pitch and Exposure

Proper weather exposure is important and depends largely on roof pitch. On roof slopes of 1:3 (4" in 12") or steeper, the standard exposures are 125 mm (5") for 400 mm (16") shingles, 140 mm (5-1/2") for 455 mm (18") shingles and 190 mm (7-1/2") for 610 mm (24") shingles. On roof slopes less than 1:3 (4" in 12") to a minimum of 1:4 (3" in 12"), exposures shall be as follows: 95 mm (3-3/4") for 405 mm (16") shingles, 105 mm (4-1/4") for 455 mm (18") shingles and 145 mm (5-3/4") for 610 mm (24") shingles.

## Roof Application

- Shingles normally are applied in straight, single courses. But application may be varied to achieve certain effects (thatch, serrated, weave and ocean wave applications are common styles). The following applies regardless: shingles must be tripled at all eaves, and butts of first-course shingles should project 40 mm (1-1/2") beyond the roof edge or far enough to ensure proper spillage into gutter. Maximum recommended exposures must not be exceeded. Spacing between adjacent shingles (joints) shall be 6 mm (1/4") nominal. Joints in any one course shall be separated not less than 40 mm (1-1/2") from joints in adjacent courses, and in any three courses no two joints should be in direct alignment.
- Shingles shall project a minimum of 20 mm (3/4") at gable ends.
- Underlayment shall be minimum No. 15 perforated asphalt-saturated felt conforming to CSA A123.3 M 1979 and/or ASTM D226-95. Fasten one ply No.15 Felt to deck with sufficient nails to hold in place until shingling. Side laps a minimum 50 mm (2") and end laps a minimum 150 mm (6").
- If required by Building Code, eave protection must consist of a minimum of self-adhesive, rubberized asphalt sheet material 2.2 kg/m<sup>2</sup> (No. 50) Type S smooth surface roll roofing or two plies of No. 15 asphalt felt lapped 485 mm (19") and cemented together with lap cement, extending from the edge of the roof a minimum distance of 915 mm (36") up the roof to a point not less than 300 mm (12") inside the inner face of the exterior wall. If a gutter is present, the eave protection shall extend a minimum of 40 mm (1-1/2") behind the gutter.

*Note:* Polyethylene eave protection is not permitted.

## Hips and Ridges

- A strip of No. 15 roofing felt shall be applied at hips and ridges prior to capping.
- All hips and ridges shall be of the alternate overlap type with concealed nailing. Either site-made or factory-assembled hip and ridge units may be used. Hip and ridge capping must be manufactured from products and grades which conform to CSA 0118.1 and Building Code requirements. Weather exposure should be the same as the field of the roof. Nails must be longer than those used in the field of the roof and of sufficient length to penetrate the underlying sheathing a minimum of 20 mm (3/4") or, in the case of plywood, completely through the sheathing.
- Shakes/Shingles used to manufacture hip and ridge capping shall be fastened (joined) together with a minimum on one corrosion resistant nail (hot dipped zinc, aluminum, or stainless steel, type 304 or 316). Placed approximately 37 mm (1-1/2") from the butt end or alternatively fasten with four nails per cap in a staggered pattern.

- Staples or T nails are not acceptable as the only securement method for the manufacture of hip and ridge capping.
- Valleys
- Metal valley sheets shall be centre-crimped, 600 mm (24") minimum width and, for maximum life, galvanized flashings shall be painted both sides with a good grade of metal paint and underlaid with a strip of No. 15 (minimum) roofing felt. Metal gauges to RGC Guarantee Standards.
- Shingles extending into the valley should be sawn to proper mitre. No joints shall be broken into valleys, nor shingles laid with grain parallel to centre line of valley.

## Flashings

**Vertical Upstand Flashing** must be installed at all vertical intersections. When fasteners are required to secure exposed metal counter flashings only cladding screws, minimum No. 8 ( $\frac{1}{8}$ ") with a rubber gasket grommet or washer, made of metal compatible and corresponding in colour to the metal flashing material are acceptable. Nails are not acceptable as exposed fasteners to secure metal counter flashings.

Materials used must conform to Guarantee Standard A6.7, Sheet Metal Material Standards.

**Apron flashing** shall extend a minimum 125 mm (5") up vertical surfaces, 100 mm (4") over the roof material and 100 mm (4") beyond the corners.

**Step flashing** shall extend a minimum 125 mm (5") up vertical surfaces, 100 mm (4") between courses of roofing and have a 75 mm (3") headlap. Step flashing shall extend a minimum 75 mm (3") beyond the down slope corners and be folded, but not cut.

**Water diverter flashing** shall be installed at all roof eaves to direct water away from walls and into drainage systems. Diverters shall extend a minimum 125 mm (5") up vertical surfaces, 100 mm (4") over roof material and be installed on a 20-degree angle to the vertical slope.

**Backpan flashing** shall extend a minimum 150 mm (6") up vertical surfaces, 450 mm (18") up the slope and 100 mm (4") beyond the corners. Corners must be folded, but not cut. If the upstand is more than 750 mm (30") wide, a saddle is recommended. In lieu of a saddle, a backpan that extends a minimum of one-sixth the width of the upstand but not less than 150 mm (6") vertically and up the roof slope to a point equal in height but not less than 450 mm (18") must be used.

**Counter flashing** must be used to shed water from vertical surfaces to the flashings.

**Plastic vents** or vent flashing shall have a minimum 75 mm (3") flange for the roof material on the upslope side and a minimum 50 mm (2") flange for the roof material on all other sides. Plastic vents or vent flashing shall not be used for combustion or grease laden venting. Acceptable plastic vents or vent flashing must conform to CSA-A93-M82 (R1992), or ICBO #4159.

**Metal vents** or vent flashing shall have a minimum 100 mm (4") flange for the roof material on all sides and a minimum vertical sealed height of 75 mm (3"). All seams must be fully soldered or welded. Material used must conform to Guarantee Standard A6.7, Sheet metal Material Standards.

**Plumbing vent flashings** shall have a minimum 100 mm (4") flange on all sides. The flashing must allow for thermal movement of the vent pipe. Settle caps or storm collars must be used where possible. Acceptable plumbing vent flashings must conform to CSA B272-93.

## Nails and Nailing

- Each shingle shall be secured with two only 14-gauge corrosion resistant nails (hot-dipped zinc, aluminum or stainless steel, Type 304 or 316) placed approximately 20 mm ( $\frac{3}{4}$ ") from each edge and approximately 38 mm (1- $\frac{1}{2}$ ") above the butt line of the following course. Nails shall be of



sufficient length to penetrate the underlying sheathing a minimum of 20 mm (3/4") or, in the case of plywood, completely through the sheathing. Nail heads shall be driven flush and tight but not so the nail head crushes the wood. Specially marked power nailers utilizing hot-dipped galvanized (or stainless steel for treated shingles) D-Type head nails may be used. Power staplers and staples or T-nails are not permitted.

- The only acceptable nails for use with pressure treated preservative or fire retardant shingles are stainless steel nails (Type 304 or 316) or hot dip zinc-coated steel nails conforming to CSA B111. Stainless steel nails are manufactured by National Nail Inc. and may be obtained through selected RCABC Associate Members.

### **Ventilation – Attic Space/Cathedral/Insulated Roof Assemblies**

The attic or ceiling space must be adequately ventilated according to appropriate Building Code standards. The design and selection of the ventilation system is the responsibility of the design authority.

Cathedral ceiling and/or insulated roof assemblies must have a minimum space for unobstructed air movement of 63 mm (2.5"), between the roof sheathing and the insulation where joist spaces are not individually vented, the spaces must be cross-strapped with purlins that are not less than 38 mm (1 ½") x 38 mm (1 ½") installed on top of the roof joists.

*Note:* The B.C. Building Code Part 9 for Housing and Small Buildings, Section 9.19 Roof Spaces, 9.19.1.3 Clearances requires:

1. Not less than 63 mm (2.5") of space shall be provided between the top of the insulation and the underside of the roof sheathing.
2. Ceiling insulation shall be installed in a manner that will not restrict a free flow of air through roof vents or through any portion of the attic or roof space.

Cedar shingles applied over insulation and shingles applied to sheathing over insulation without the appropriate air space are not permitted for this application in the RGC Guarantee Program.

### **CEDAR SHINGLES SIDEWALL APPLICATION**

Sidewall applications are not applicable for the RGC Guarantee Program; this specification is included for your information only.

#### **Materials**

Shingles shall be No. 1 Blue Label or No. 2 Red Label grade.

#### **General**

There are two basic methods of shingle sidewall application, single-coursing and double-coursing. In single-coursing, shingles are applied much the same as in roof construction, but greater weather exposures are permitted. Maximum exposure for single-coursing No.1 Grade shingles shall be 190 mm (7-1/2") for 405 mm (16") shingles, 215 mm (8-1/2") for 455 mm (18") shingles and 290 mm (11-1/2") for 610 mm (24") shingles. When single-coursed, a shingle wall shall be double layered at the foundation line (single underlay). Double-coursing allows for the application of shingles at extended weather exposure when applied over undercoursing grade shingles. Double-coursing gives a deep, bold shadow line. Maximum exposure for double-coursing No.1 Grade shingles shall be 305 mm (12") for 405 mm (16") shingles, 355 mm (14") for 455 mm (18") shingles and 405 mm (16") for 610 mm (24") shingles. When double-coursed, a shingle wall shall be triple-layered at the foundation line (double underlay).

Exposures for No.2 Grade shingles shall be reduced 50 mm (2") for 16" shingles, and 50 mm (2") for 18" shingles.

### **Nails and Nailing**

Single-coursed application features concealed nailing with two only box nails of sufficient length to penetrate the sheathing a minimum of 20 mm (3/4") driven approximately 25 mm (1") above the butt line of the following course and approximately 20 mm (3/4") from each edge. For double-coursed application each outer course shingle shall be secured with at least two small-headed nails driven approximately 50 mm (2") above the butt line and approximately 20 mm (3/4") from each side. With shingles wider than 200 mm (8"), two additional nails approximately 25 mm (1") apart shall be placed across the face of the shingle at the same distance above the butt line. Nail heads shall be driven flush and tight but not so the head crushes the wood.

### **Corners**

Outside corners shall be constructed with an alternate overlap of shingles between successive courses. Inside corners shall be mitred over a metal flashing or may be made by nailing a S4S 38 mm (1-1/2") square strip in the corner over a metal flashing after the shingles of each course are butted to the square strip.

## **RED CEDAR SHAKES ROOFING APPLICATION**

### **Materials**

- Red cedar shakes shall be premium or No.1 Grade of straight-split, taper-split, hand-split and resawn or taper-sawn conforming to CSA 0118.1 except that shakes shall be 100% edge grain. No flat grain is acceptable. Shakes shall be not less than 455 mm (18") long and not less than 100 mm (4") nor more than 350 mm (14") wide with a butt thickness of not more than 32 mm (1-1/4") and not less than 9 mm (3/8" nominal).
- Flashings shall be 0.56 mm (26 gauge) galvanized iron or 0.80 mm (0.032") aluminum.
- Roof Sheathing
- Red cedar shakes may be applied over spaced sheathing or solid sheathing. When spaced sheathing is used, minimum 19 mm x 89 mm (1" x 4") boards shall be spaced on centres equal to the weather exposure at which the shakes are laid but never more than 190 mm (7-1/2") for 455 mm (18") shakes nor more than 250 mm (10") for 610 mm (24") shakes.

*Note:* If 24" shakes are used, 19 mm x 140 mm (1" x 6") boards are mandatory.

### **Roof Pitch and Exposure**

- The minimum allowable roof pitch for shakes is 1:3 (4" in 12"). Proper weather exposure is important and shall be limited to the following maximum exposures for a 2-ply roof: 190 mm (7-1/2") for 450 mm (18") shakes and 250 mm (10") for 600 mm (24") shakes.
- For a 3-ply roof the maximum exposures are 140 mm (5-1/2") for 450 mm (18") shakes and 190 mm (7-1/2") for 610 mm (24") shakes.

### **Roof Application**

If required by Building Code, eave protection must consist of a minimum of self-adhesive rubberized asphalt sheet material, 2.2 kg/sq. m (No.50) Type S smooth surface roll roofing or two plies of No.15 asphalt felt lapped 485 mm (19") and cemented together with lap cement, extending from the edge of the roof a minimum distance of 915 mm (36") up the roof to a point not less than 300 mm (12") inside the inner face of the exterior wall. If a gutter is present the eave protection shall extend a minimum of

40 mm (1-1/2") behind the gutter. The beginning or starter course shall be doubled or tripled and butts shall project far enough beyond the roof edge to ensure proper spillage into gutter.

The bottom course may be either 455 mm (18") shakes or cedar shingles No.1 grade or better. Straight-split shakes shall have a tapered starter course (cedar shingles).

After applying each course of shakes, a 455 mm (18") wide strip of No.15 asphalt felt shall be laid over the top portion of the shakes extending onto the sheathing. The bottom edge of the felt shall be positioned at a distance equal to twice the weather exposure above the butt (*Note: If open sheathing is used ensure that the top edge of the felt is laying on and secured to the strapping*). For example 610 mm (24") shakes laid with 250 mm (10") exposure would have the felt applied 500 mm (20") above the shake butts; thus the felts will cover approximately 100 mm (4") of the top of the shake and extend approximately 355 mm (14") onto the sheathing. When straight-split shakes are used, the "Froe-end" (the end from which the shakes have been split and which is smoother) shall be laid upper most, i.e. toward the ridge. Joints in adjacent courses shall be broken or off-set not less than 40 mm (1-1/2"), and when laid in a 3-ply application, in any three courses no two joints should be in direct alignment. Individual shakes shall be spaced 10 mm (3/8") to 16 mm (5/8") apart to allow for possible expansion. Shakes shall project a minimum of 20 mm (3/4") at gable ends.

After applying each course of shakes, a 455 mm (18") wide strip of No.15 asphalt felt shall be laid over the top portion of the shakes extending onto the sheathing. The bottom edge of the felt shall be positioned at a distance equal to twice the weather exposure above the butt (*Note: If open sheathing is used ensure that the top edge of the felt is lying on and secured to the strapping*). For example 610 mm (24") shakes laid with 250 mm (10") exposure would have the felt applied 500 mm (20") above the shake butts; thus the felts will cover approximately 100 mm (4") of the top of the shake and extend approximately 355 mm (14") onto the sheathing. When straight-split shakes are used, the "Froe-end" (the end from which the shakes have been split and which is smoother) shall be laid upper most, i.e. toward the ridge. Joints in adjacent courses shall be broken or off-set not less than 40 mm (1-1/2") and when laid in a 3-ply application, in any three courses no two joints should be in direct alignment. Individual shakes shall be spaced 10 mm (3/8") to 16 mm (5/8") apart to allow for possible expansion. Shakes shall project a minimum of 20 mm (3/4") at gable ends.

### **Hips and Ridges**

A strip of No. 15 roofing felt shall be applied at hips and ridges prior to capping.

All hips and ridges shall be of the alternate overlap type and at same weather exposures as the field of the roof. Either site-made or factory-assembled hip and ridge units may be used.

Hip and ridge capping must be manufactured from the same grade product (100% edge grain) as used in the field of the roof. Nails must be longer than those used in the field of the roof and of sufficient length to penetrate the underlying sheathing a minimum of 20 mm (3/4") or, in the case of plywood, completely through the sheathing.

Shakes/Shingles used to manufacture hip and ridge capping shall be fastened (joined) together with a minimum of one corrosion resistant nail (hot dipped zinc aluminum or stainless steel, type 304 or 316) placed approximately 75 mm (1 1/2") from the butt end or alternatively fasten with four nails per cap in a staggered pattern.

Staples or T nails are not acceptable as the only securement method for the manufacture of hip and ridge capping.

### **Valleys**

Metal valley sheets shall be centre-crimped, 610 mm (24") minimum width and, for maximum life, galvanized flashings shall be painted both sides with a good grade of metal paint and underlaid with a strip of minimum No.15 roofing felt.

Shakes extending into the valley should be sawn to the proper mitre. No joints shall be broken into valleys nor shakes laid with grain parallel to centre line of valley.

## Flashings

**Vertical Upstand Flashing** must be installed at all vertical intersections. When fasteners are required to secure exposed metal counter flashings only cladding screws, minimum No. 8 ( $\frac{1}{8}$ " ) with a rubber gasket grommet or washer, made of metal compatible and corresponding in colour to the metal flashing material are acceptable. Nails are not acceptable as exposed fasteners to secure metal counter flashings.

Materials used must conform to Guarantee Standard A6.7, Sheet Metal Material Standards.

**Apron flashing** shall extend a minimum 125 mm (5") up vertical surfaces, 100 mm (4") over the roof material and 100 mm (4") around the corners.

**Step flashing** shall extend a minimum 125 mm (5") up vertical surfaces above the finished roof surface, 100 mm (4") between courses of roofing and have a 75 mm (3") headlap. Step flashing shall extend a minimum 75 mm (3") beyond the down slope corners and be folded, but not cut.

**Water diverter flashing** shall be installed at all roof eaves to direct water away from walls and into drainage systems. Diverter shall extend a minimum 125 mm (5") up vertical surfaces, 100 mm (4") over roof material and be installed on a 20-degree angle to the vertical slope.

**Backpan flashing** shall extend a minimum 150 mm (6") up vertical surfaces, 450 mm (18") up the slope and 100 mm (4") beyond the corners. Corners must be folded, but not cut. If the upstand is more than 750 mm (30") wide, a saddle is recommended. In lieu of a saddle, a backpan that extends a minimum of one-sixth the width of the upstand but not less than 150 mm (6") vertically and up the roof slope to a point equal in height but not less than 450 mm (18") must be used.

**Counter flashing** must be used to shed water from vertical surfaces to the flashings.

**Metal vents or vent flashing** shall have a minimum 100 mm (4") flange for the roof material on all sides and a minimum vertical sealed height of 75 mm (3"). All seams must be fully soldered or welded. Material used must conform to Guarantee Standard A6.7, Sheet metal Material Standards.

**Plumbing vent flashings** shall have a minimum 100 mm (4") flange on all sides. The flashing must allow for thermal movement of the vent pipe. Settle caps or storm collars must be used where possible. Acceptable plumbing vent flashings must conform to CSA B272-93.

## Nails and Nailing

- Each shake shall be secured with two only 14-gauge corrosion resistant nails (hot-dipped zinc, aluminum or stainless steel, Type 304 or 316) placed approximately 20 mm ( $\frac{3}{4}$ " ) from each edge and approximately 40 mm (1-1/2") above the butt line of the following course. Nails shall be of sufficient length to penetrate the underlying sheathing a minimum of 20 mm ( $\frac{3}{4}$ " ) or, in the case of plywood, completely through the sheathing. Nail heads shall be driven flush and tight but not so the nail head crushes the wood.
- The only acceptable nails for use with pressure treated, preservative, or fire retardant shakes are stainless steel nails (Type 304 or 316) or hot dip zinc-coated steel nails conforming to CSA B111. Stainless steel nails are manufactured by National Nail Inc. and may be obtained through selected RCABC Associate Members.
- Specially marked power nailers utilizing hot-dipped galvanized (or stainless steel for treated shakes) D Type head nails may be used. Power staplers and staples or T nails are not permitted.

### **Ventilation – Attic Space/Cathedral/Insulated Roof Assemblies**

The attic or ceiling space must be adequately ventilated according to appropriate Building Code standards. The design and selection of the ventilation system is the responsibility of the design authority.

Cathedral ceiling and/or insulated roof assemblies must have a minimum space for unobstructed air movement of 63 mm (2.5"), between the roof sheathing and the insulation where joist spaces are not individually vented, the spaces must be cross-strapped with purlins that are not less than 38 mm (1 ½") x 38 mm (1 ½") installed on top of the roof joists.

*Note:* The B.C. Building Code Part 9 for Housing and Small Buildings, Section 9.19 Roof Spaces, 9.19.1.3 Clearances requires:

1. Not less than 63 mm (2.5") of space shall be provided between the top of the insulation and the underside of the roof sheathing.
2. Ceiling insulation shall be installed in a manner that will not restrict a free flow of air through roof vents or through any portion of the attic or roof space.

Cedar Shakes applied over insulation and shakes applied to sheathing over insulation without the appropriate air space are not permitted for this application in the Guarantee Program.

### **CEDAR SHAKE SIDEWALL APPLICATION**

Sidewall applications are not applicable for the RGC Guarantee Program; this specification is included for your information only.

#### **General**

Maximum recommended weather exposure for single-coursed wall construction is 215 mm (8-1/2") for 455 mm (18") shakes and 290 mm (11-1/2") for 610 mm (24") shakes. Nailing shall be concealed with nailing points 25 mm (1") above the butt line of the course to follow.

Double-coursed application requires an underlay of shakes or cedar shingles. Weather exposures up to 355 mm (14") are permissible with 455 mm (18") resawn shakes and up to 500 mm (20") with 610 mm (24") resawn or taper-split shakes. If straight-split shakes are used, the double-coursed exposure may be 405 mm (16") with 455 mm (18") shakes and 560 mm (22") for 610 mm (24") shakes. For double-coursed application each other course shake shall be secured with at least two small-headed nails driven approximately 50 mm (2") above the butt line and approximately 19 mm (3/4") from each side. With shakes wider than 200 mm (8"), two additional nails, approximately 25 mm (1") apart, shall be placed across the face of the shingle at the same distance above the butt line. Nail heads shall be driven flush and tight but not so the head crushes the wood.

#### **Corners**

Outside corners shall be constructed with an alternate overlap of shakes between successive courses. Inside corners shall be mitred over a metal flashing or may be made by nailing a S4S 38 mm (1-1/2") square strip in the corner over a metal flashing after the shakes of each course are butted to the square strip.

## CEDAR ROOF FLASHING

### Flashing Details for Shingle and Shake Valleys

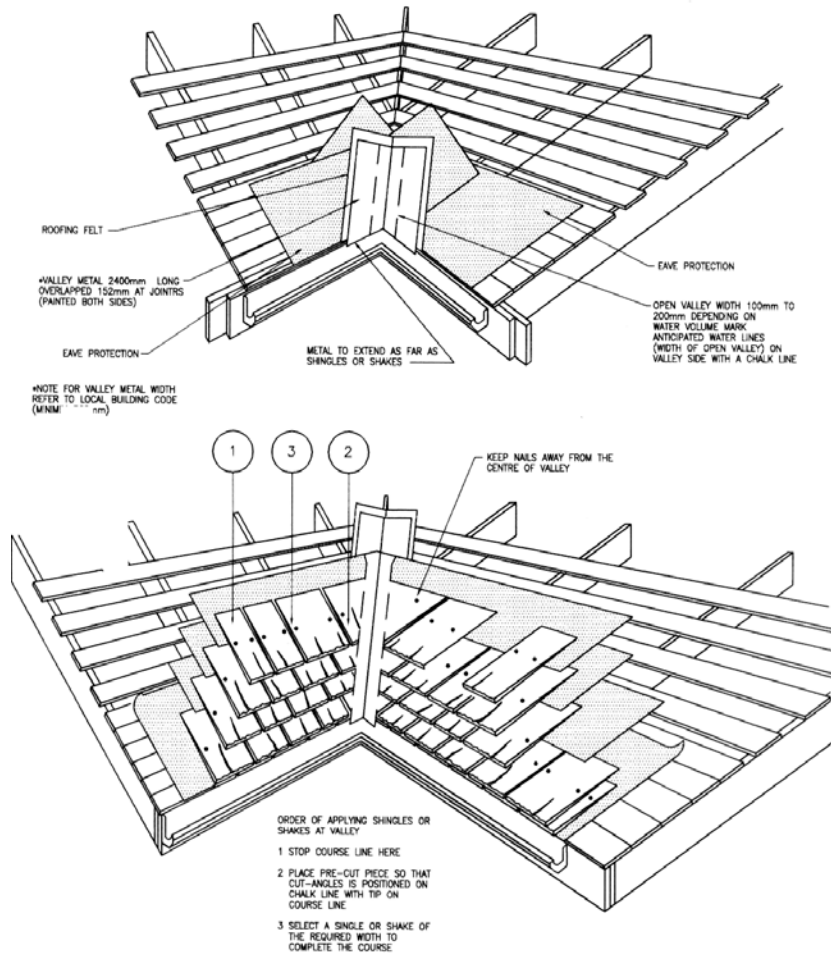

Flashing Details for Typical Roof Projections

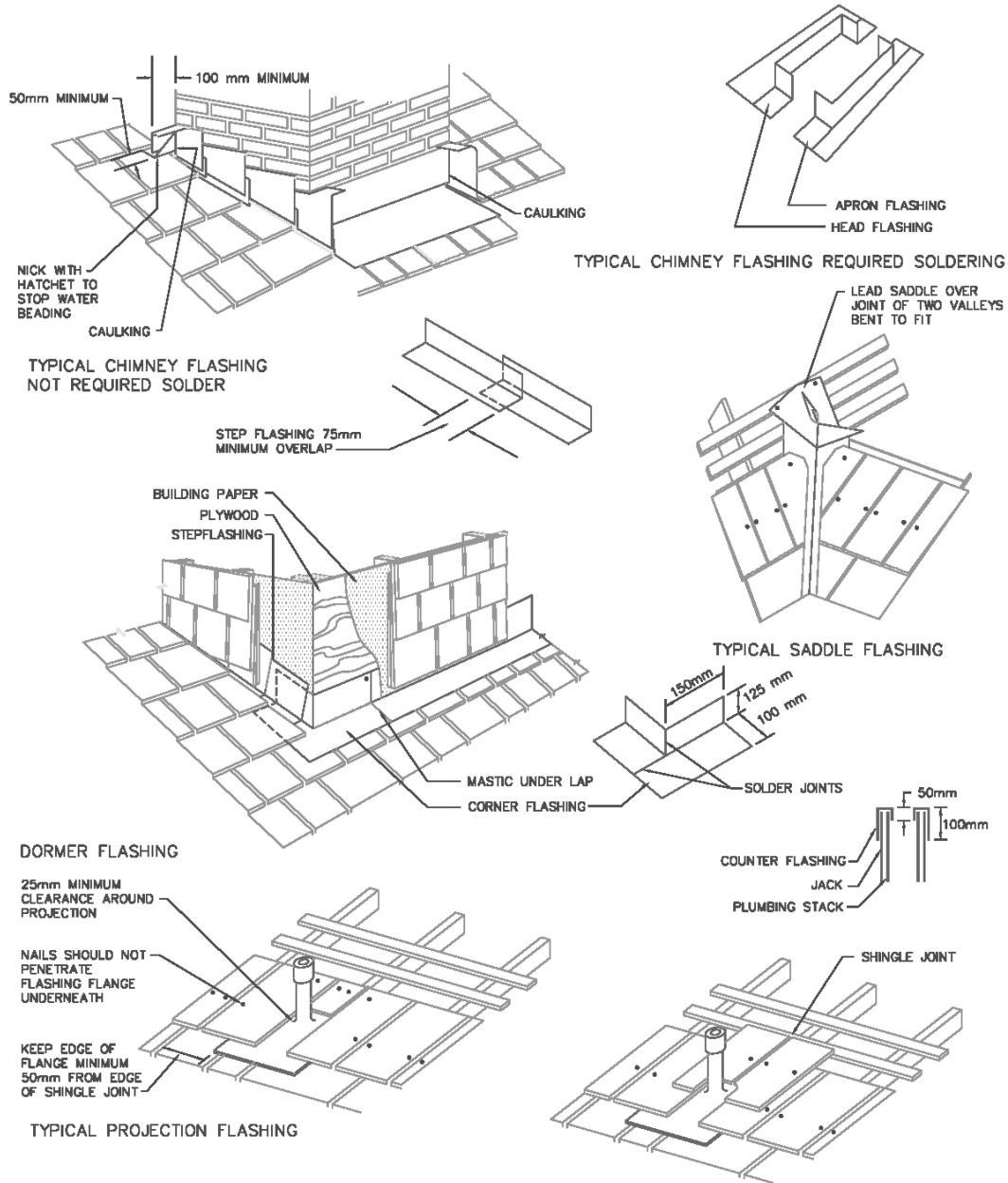

## CEDAR HIP AND RIDGE CAP

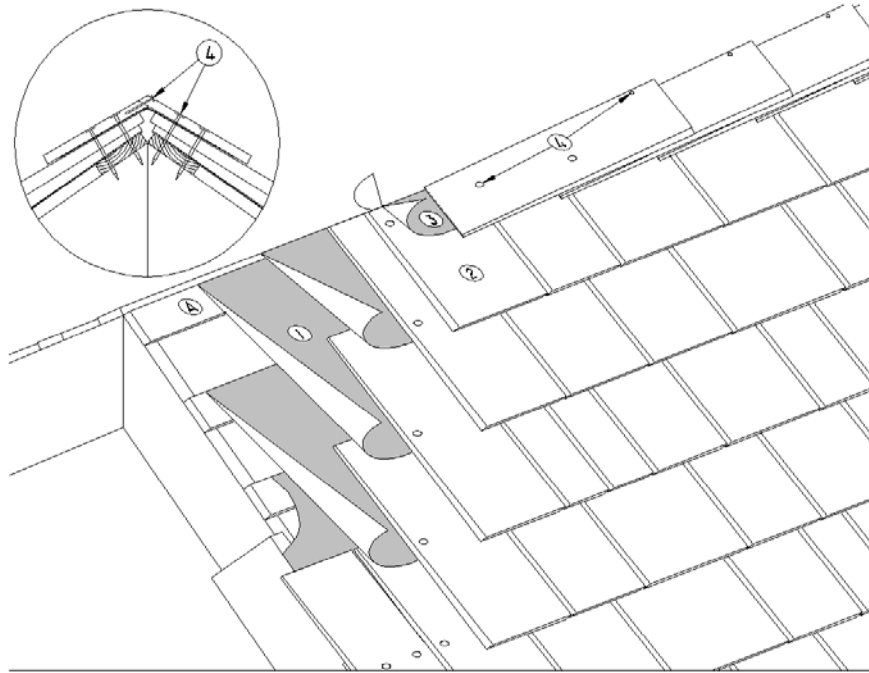

## WORK INCLUDED:

1. Interlay: Minimum No. 15 asphalt saturated felt not less than 450 mm (18") shall be laid between courses of cedar shakes starting from a distance equal to double the weather exposure from the butt. On open sheathing top edge of interlay must rest on and be secured to the strapping.
2. Final Course: Trim final course to top point of ridge or hip.
3. Ridge Underlay: A strip of minimum No. 15 asphalt saturated felt prior to capping.
4. Ridge Cap: Optional locations for second nail. All ridges and hips shall be of the alternate overlap type and at the same exposure as the field of the roof. Each side shall be fastened with 2 nails not in the same line of grain (staggered). Nails should be longer than the field nails and long enough to penetrate the sheathing a minimum of 20 mm (3/4") or in the case of plywood, completely through the sheathing, OR 1 nail per side and an additional nail through the butt end edge at peak of ridge cap (staples alone are not sufficient).

## RELATED WORK BY OTHERS

- A. Sheathing: Minimum 19 mm x 89 mm (1" x 4") boards spaced to match exposure of shakes or shingles, though minimum 19 mm x 140 mm (1" x 6") boards are mandatory for 24" shakes. Solid sheathing is also acceptable.



## SECTION 4.c CONCRETE AND CLAY TILES

### Materials

Concrete roof tiles are available in a wide variety of colours and styles and are frequently used to enhance the overall aesthetics of buildings.

Concrete roof tiles are made of varying proportions of Portland cement, sand and water, which is extruded on moulds under high pressure. Colour is either added to the surface or dispersed throughout the tile. Surface coloured tiles have more variety and resistance to staining by mildews, moss and pollution. Colour-through tiles keep their appearance better in heavy freeze-thaw cycling.

Standard weight concrete tiles have a minimum mass of 40 kg./m<sup>2</sup> (8 lbs./sq. ft.) which should be considered when calculating deck load. Manufacturers' tile weights may vary. The minimum recommended slope for concrete tiles is 4"/12" (1:3).

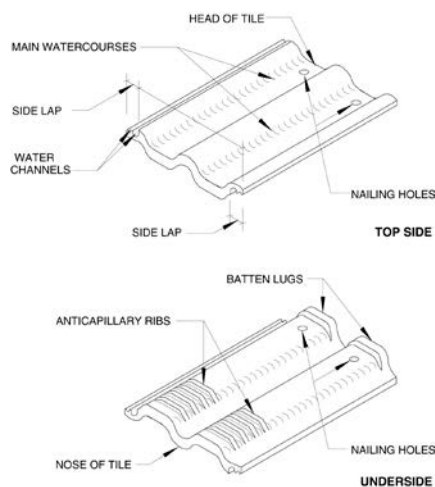

Concrete roof tiles come in two style groups with various colours and finishes:

- Roll Tile        - S Shape (Spanish S)
- Flat Tile        - Shake or Slate Shaped
- Ribbed

Concrete tiles are typically installed over rigid underlayment or rolled underlayment on solid sheathing. The tiles are supported by 25 mm x 100 mm (1" x 4") nominal battens, which the tiles 'lug' rests against, and nails through two holes which are concealed by the lap of the next course.

### Application Details

RGC recommends that concrete tile installations conform to CSA Standards A220.1-M91

The details listed are a general guide to the application of concrete tiles' underlayment, battens, layout and related flashings.

**Underlayment** – Underlayment is an integral part of concrete tile roofing systems.

**Rigid Underlayment** – Made of several plies of wood fibre material then laminated with aluminum on one side and polyethylene on the other. It comes in sheet form and may be applied directly over roof joists under the battens.

**Rolled Underlayment:** Can be #30 organic felt or a multi-layered laminated product. Felt underlayment can only be used over plywood sheathing, under the battens.

All penetrations, soil stacks, chimneys, vents, etc. should be sealed to the underlay.

Underlayments must be applied in 'shingle' fashion overlapping the fascia by at least 40 mm (1-1/2").

Rigid underlayment, nominally 1200 mm x 2500 mm (48" x 100"), is installed with the long side perpendicular to the slope with a minimum 50 mm (2") side lap centred on the rafters a min. 100 mm (4") overlap on previous courses.

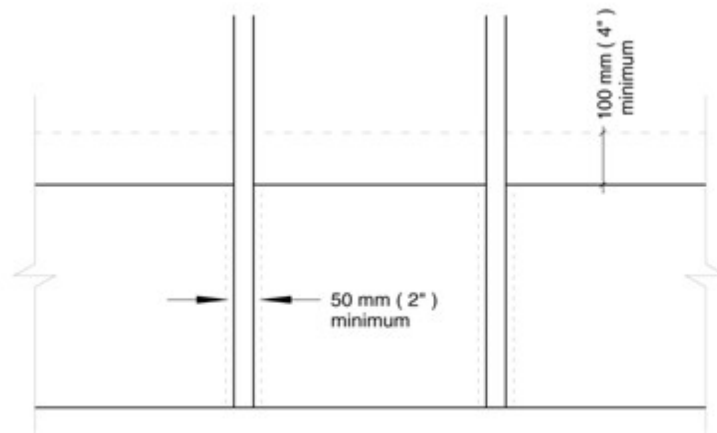

Rolled underlayment is 900 mm - 1000 mm (36" - 39") in width and varying lengths. It is installed perpendicular to the slope with succeeding courses overlapping the previous by a minimum of 50 mm (2") and end laps a minimum of 150 mm (6").

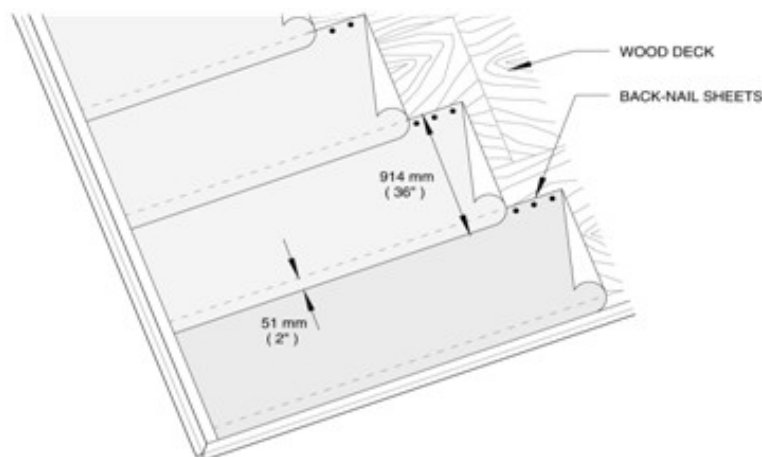

Where a fascia board is used, the underlayment shall be fastened to the top of the fascia board at the junction of the rafter and fascia.

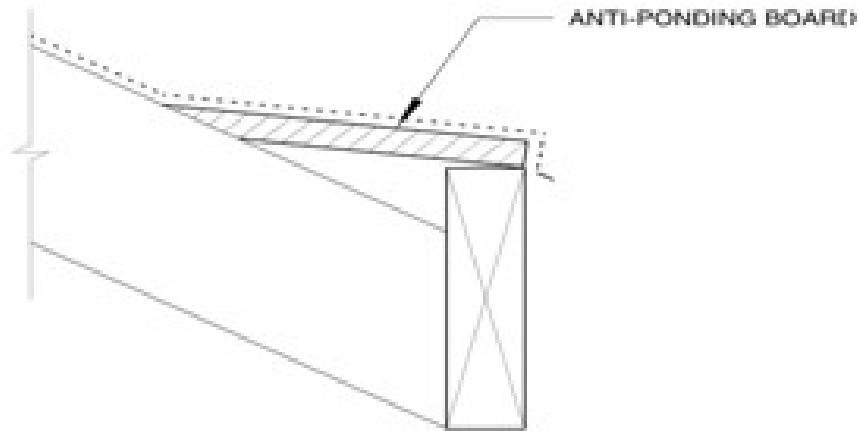

The underlayment shall lap ridges and hips 150 mm (6") in each direction, providing a total 300 mm (12") overlap.

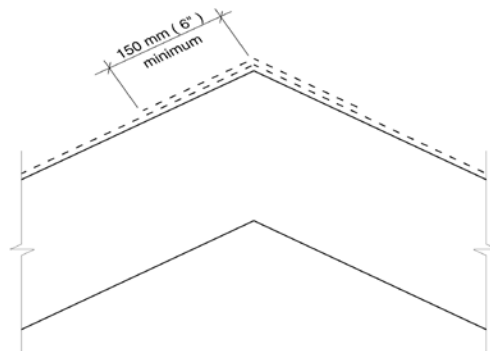

### Tile Application Details

#### Battens (Strapping):

Battens are installed in conjunction with and overtop of the underlayment. The battens provide support and securement for concrete tiles.

Battens are installed perpendicular to the slope, spaced to ensure a minimum 40 mm (1.5") overhang of fascia and a minimal 75 mm (3") head lap on succeeding courses. The ridge batten should be between 25 (1") and 40 mm (1.5") from the ridge board.

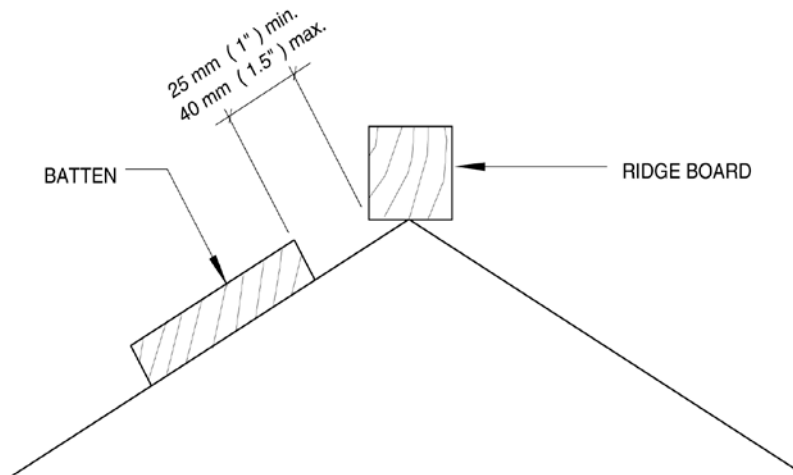
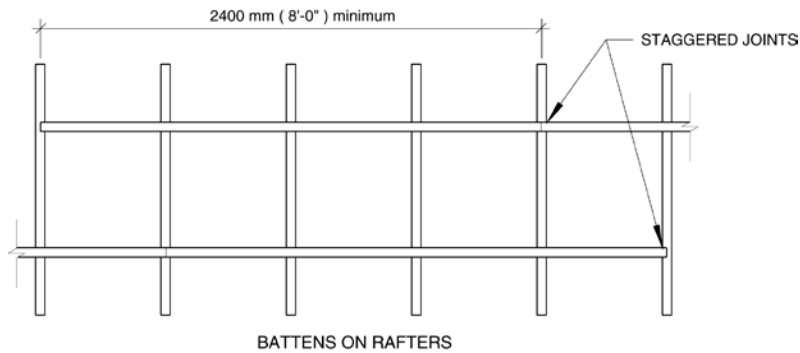

**Ridge and Hip Boards (Nailer):**

Ridge and hip boards are installed to support and provide nail securement for ridge and hip tiles. Ridge and hip boards must be installed to a height which will support the entire weight of the tile with a minimum 3 mm (1/8") clearance of the field tiles.

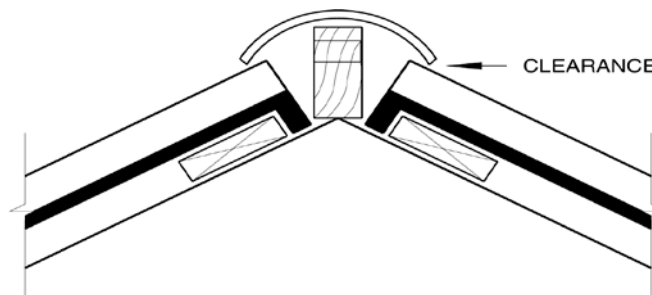

**Field Tiles:**

Concrete tiles are laid in shingle fashion starting at a bottom corner. To prevent excess traffic on the tiles, the roof should be loaded before any tiles are laid, usually in evenly spaced stacks of six.

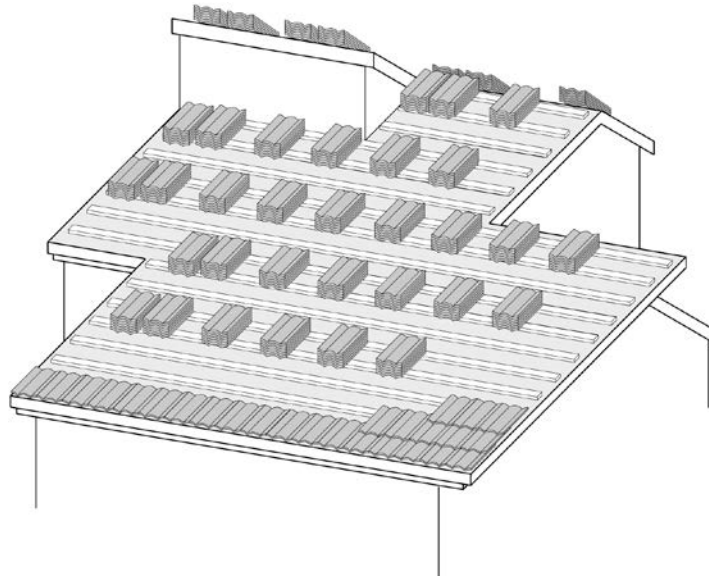

Tiles are placed with the lug resting on the upperside of the batten. Nails should be a minimum 12 ga. Hot dipped galvanized, long enough to penetrate the battens but not through, to avoid penetrating the underlay. Nails should be driven just flush. Underdriven nails can crack the tile above them. Overdriving nails can crack the tile being fastened.

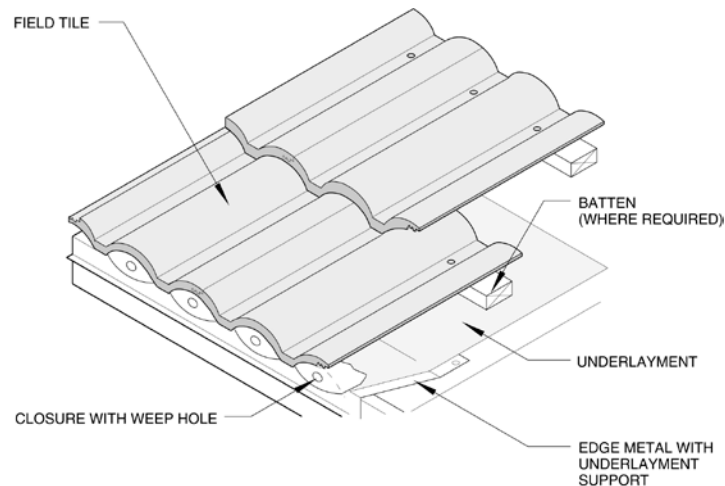

Nailing frequency is determined by slope, local wind conditions and seismic zoning.

STANDARD CONDITIONS CSA CLAUSE 11.2.2.2		
Roof Slope	Fastening for Tile	Fastening at eaves, gables, hips and ridges
$\geq 1:3 \leq 1:1.7$	Nail or clip the tiles in every third course	Nail or clip: (a) first two courses along the eaves (b) first two courses or tiles each side of hips or ridges; and (c) first two rows in from all gables
$> 1:1.7 \leq 1:1$	Nail or clip the tiles in alternate courses	
$> 1:1 \leq 1.25:1$	Nail or clip every tile	Nail or clip every tile
$> 1.25:1$	Nail or clip every tile	Nail or clip every tile
SEISMIC ZONE 4 OR GREATER CSA CLAUSE 11.2.2.3		
Roof Slope	Fastening for Tile	Fastening at eaves, gables, hips and ridges
$\geq 1:3 \leq 1:1.7$	Nail or clip the tiles in every third course	Nail or clip: (a) first three courses along the eaves (b) first three courses or tiles each side of hips or ridges; and (c) first three rows in from all gables
$> 1:1.7 \leq 1:1$	Nail or clip the tiles in alternate courses	
$> 1:1$	Nail and clip every tile	Nail and clip every tile
HIGH WIND CONDITIONS CSA CLAUSE 11.2.2.3		
Roof Slope	Fastening for Tile	Fastening at eaves, gables, hips and ridges
$\geq 1:3 \leq 1:1.7$	Nail and clip the tiles in every third course	Nail and clip: (a) first three courses along the eaves (b) first three courses or tiles each side of hips or ridges; and (c) first three rows in from all gables
$> 1:1.7 \leq 1:1$	Nail and clip the tiles in alternate courses	
$> 1:1$	Nail and clip every tile	Nail and clip every tile

In areas with both high wind and seismic activity, the more stringent requirements should apply.

## Application Details

### Valleys:

Valleys are underlaid before the field with the underlayment running centred on and parallel to the slope of the valley base. Field underlayment should overlap the valley by a minimum 150 mm (6").

Valley flashing should be 1200 mm (24") min. wide and 2400 mm (8') long with a 20 mm (1/2") divider, made of 26 ga. prepainted steel.

The flashing should be made to conform to the valley attached with clips or nails bent over the flashing but not driven through. Under 150 mm (6") min. Laps, the previous piece should be nailed.

Valley peaks and terminations of blind valleys require lead (3 lb.) transitions.

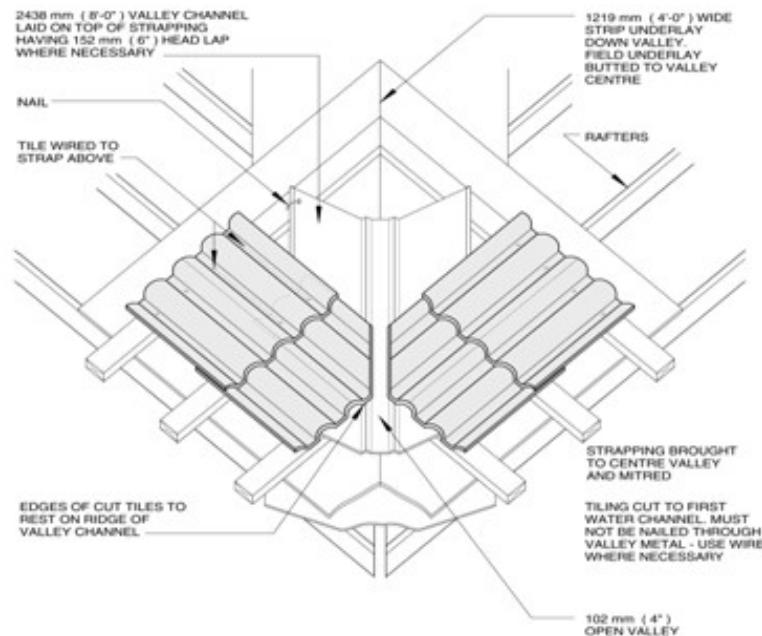
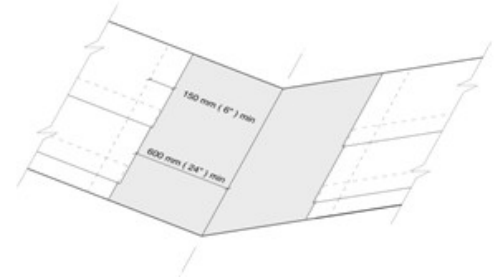

### Hips/Ridges:

Ridge and hip tiles are applied after the field tiles are terminated against the nailer board. A sealant, mortar or plaster cement should be applied to the tops of the field tile and between laps of the ridge/hip tile. This prevents entry of wind driven rain or snow.

Tiles are started at the low end of hips or the leeward end of ridges. Each tile is nailed through the hole provided into the nailer. The lap of the next tile covers the nail. The last ridge tile nails will have to be caulked.

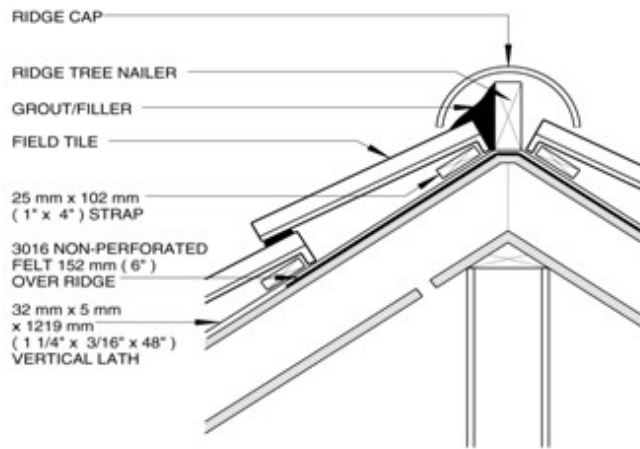
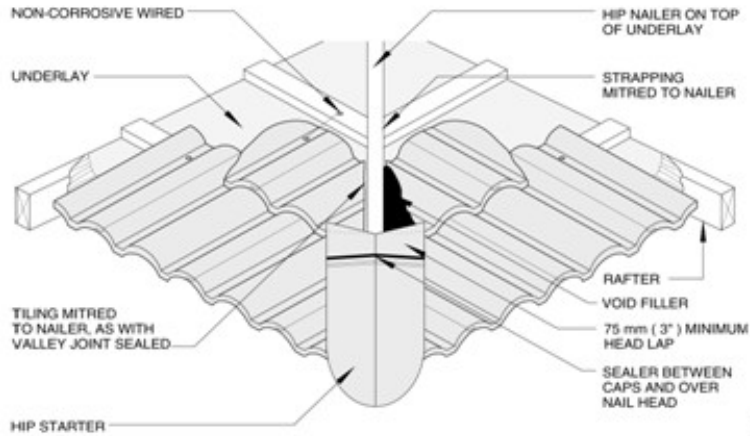

**Rake Tiles:**

Rake tiles cover the exposed edge of field tiles at fascia boards. This helps prevent wind driven rain from entering the system and provides an attractive finish. Rake tiles “butt” against the lower edge of the field tile courses then are fastened with two nails into the fascia.

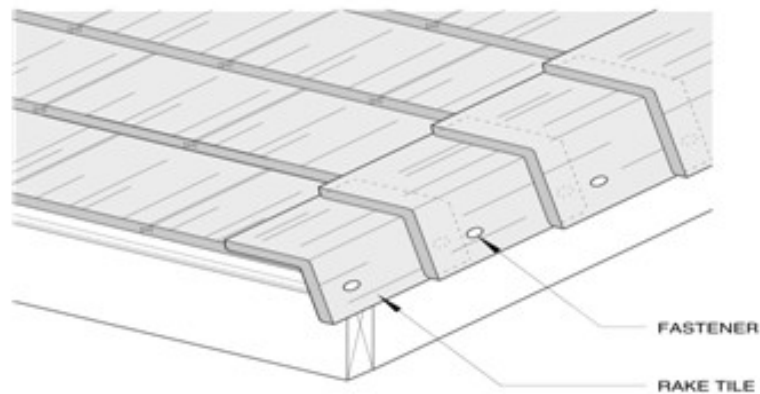

EXAMPLE OF SPECIALTY RAKE TILE



**Flashings:**

Flashings bridge the gap between field areas and any protrusions such as pipes, vents, and adjoining walls. Because these items impede the flow of water, small deficiencies can cause high amounts of water to enter the building. Proper detail work will make the difference between a successful or problematic roof.

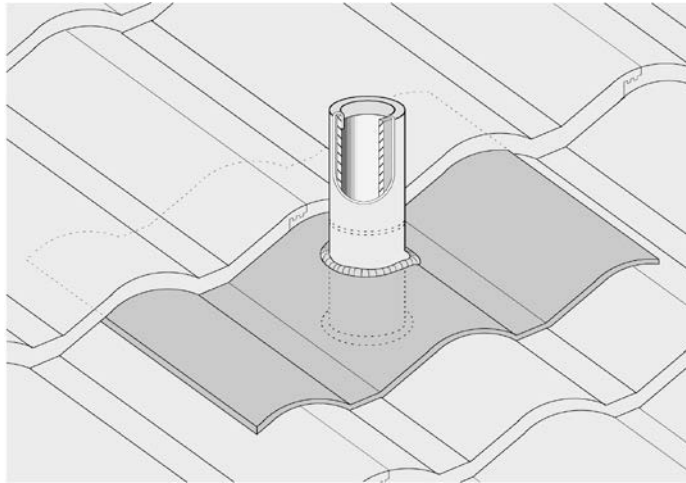
**Pipe Flashings:**

Pipe flashings are made of lead which conforms well to the tiles' surface. They are applied over the course of tile, penetrated by the pipe and under the next course with a 75 mm (3") min. lap.

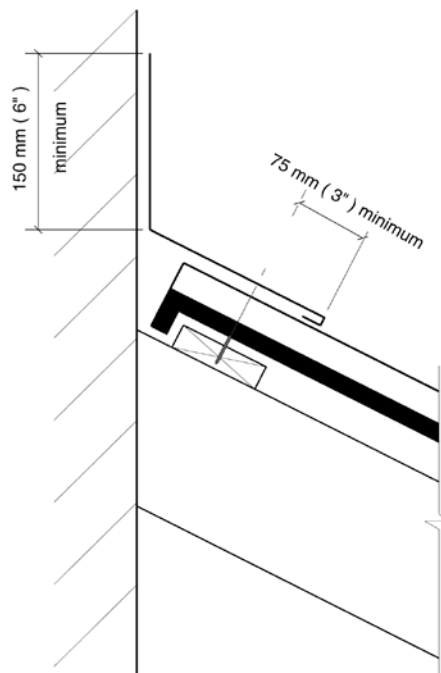
**Walls Perpendicular to Slope:**

Flashing for a wall termination should lap the tile by a minimum of 100 mm (4"). Material should be the 26 ga. pre-painted galvanized with S locks or standing seams to join lengths.

A mortar or mastic bedding should be applied to the tops of the concrete tile before flashing to prevent windblown rain or vermin from entering.

### Curb Flashings:

Curb flashings are applied around skylights, chimneys or other larger penetrations. The basic principle is to deflect the water rushing against the uproof side, safely around then on top of the tiles on the down roof side.

The recommended method is to use 3 lb. lead sheeting due to its malleability and, therefore, easy conformance to the tile's contour.

Upper and lower flashings should be conformed with tile's surface.

Upper flashings should extend 150 mm (6") past corners on each side, then formed around soakers.

Lower flashing should extend 100 mm (4") past corners and lapped under the soakers.

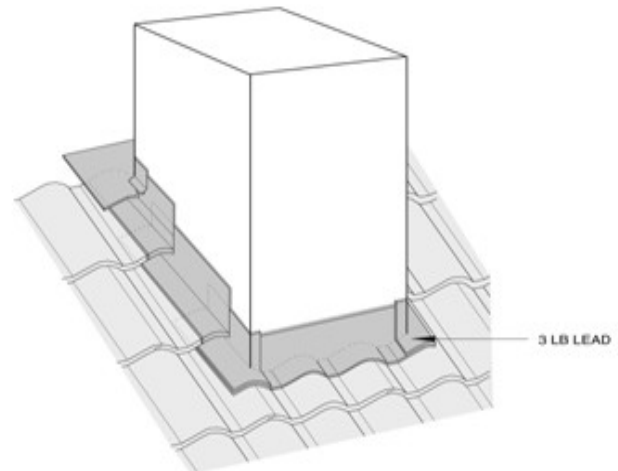

CHIMNEY FLASHING

### History

Tile roofing has a long standing history as a roofing material which adds character and distinction to residential architecture. It is also associated with traditional institutional architecture such as that which is found on college campuses and in major public building. Every year, more and more Canadians are getting the message that beautiful, long-lasting and fireproof tile roofs offer a high value for roofing dollar expenditure. In fact, experienced roofing contractors who have added tile roofs to their application portfolio have found that the general buying public perceives the value of tile roofing at a level much higher than the increased applied cost. In recent years, the long standing popularity of roofing tile in residential applications has been exploited by designers of shopping centres, hospitals, hotels, condominium developments and other commercial projects that want to project an image of affluence and permanence.

Its association with residential architecture is also partly responsible for roofing tile's popularity as a major design element. This allows designers to tie together the commercial/light industrial and residential structures found in mixed-use, suburban developments into a single, homogenous entity or blend commercial buildings into residential areas. Tile roofing is also playing a significant role in the current boom in the renovation and reconstruction of commercial and industrial structures. A tile roof can be a significant part of the design strategy in turning an old factory or train station into a retail centre or condominium.

The design objectives that can be achieved with the use of roofing tile are many, derived primarily from the fact that this is a natural, extremely durable material that offers virtually unlimited options in terms of colour, texture and shape. There is more to a tile roof than superior aesthetics. Most building owners are interested in a roof that will give them at least 25 to 30 years without maintenance problems. When properly designed and constructed, using first-quality materials, tile roofs can last 75 years or more,

making them a very popular choice where building owners (such as universities, government bodies and private foundations) expect to retain ownership of the building for decades.

Snow and ice build-ups are detrimental to all roof coverings and tile is no exception. Special consideration must be given to designing tile roof installations in those areas subject to heavy snow and freeze/thaw cycles. Individual roof tile manufacturers publish suggested details for constructing pitched roofs in cold climates.

### ***Life Expectancy***

Different tiles have different life expectancies. In fact, life expectancy for a roofing tile can range from 10 to 100 years. In fact, English manufacturers of concrete tile give 100 year warranties on their products.

The generally accepted testing standards that certify roofing tile quality are minimum standards and cannot be viewed as a guarantee of the long-term performance of the tile. Therefore, the only reliable guide available to the roofer and specifier whose horizons extend out for decades is the manufacturer's reputation and the terms of his warranty. Terms will vary from no warranty at all to coverage of workmanship and materials for as much as 50 years.

### ***What Makes One Tile Better Than Another?***

Because so much serviceability is expected from the tiles, leading roof tile manufacturers initiate and maintain strict quality control procedures in their plants. The resultant products are predictably consistent in dimension, invariably strong and reliably water and freeze-thaw resistant. There is no reluctance to guarantee roof tiles for as long as 50 years.

Differences in quality may not be visually apparent at first. Quality is determined by the care and consistency with which the manufacturer selects and blends his raw materials and the skill of his controls over the manufacturing processes. The object is a tile with minimal porosity and optimal compressive strength. These are the major factors that determine how well the tile can stand up to the normal extremes of the freeze/thaw cycle and continuous exposure to the elements.

A tile's compressive strength, together with the design of the tile pattern, will determine its walk-on strength. The tile cannot be too thin and light to be walked on during construction. It must be designed to perform reliably in all weather and all locations, and its configuration must assure maximum shedding of precipitation.

In general, the more complex the design of the roof, whether it be constructed of tile or of another material, the more opportunities there are for roofing problems. The more planes there are to the roof, the more junctures there are that require flashing. They are both the most critical point in the water shedding process and the most likely places for water to gain entrance.

### ***Overweight?***

One of the most common misconceptions pertaining to tile roofs is a preconceived "problem" with weight. On new construction, there simply is no problem. The architect or designer specifies the appropriate framing system or the builder simply follows framing tables for heavy roofs in modern building codes.

Reroofing existing structures presents more of a challenge, but that in general is easily overcome by additional bracing as needed when indicated by a structural engineer's recommendations following inspection. He will visually inspect the rafters, walls and wall openings to see how long the spans are. If this is not done, you can open yourself up to a lot of potential problems and liability.

While simplicity in roof design is the most obvious approach to reducing the potential for performance problems, it is not the only one. Highly complex roof designs, incorporating peaks, valleys, dormers

and a wealth of special design features, can be expected to perform reliably if careful attention is given to the initial selection of materials and a regular regimen of inspection is followed.

### **Tile Profile**

The tile industry generally separates roof tile designs into three categories; high profile, low profile, or flat.

High profile tiles are the familiar mission, barrel, "S" or Spanish styles. This type tile is the oldest type of manufactured roofing materials known to man. The Romans, Greeks, and the Chinese before them, learned how to press wet clay into their thighs or into wooden molds and bake the clay under the sun or in ovens heated by steam or burning wood to form a hard, durable finish. Tile roofs installed centuries ago still protect ancient buildings standing today. They are available in a variety of integral and applied colours.

Low profile roof tiles are manufactured in numerous different styles by several roof tile manufacturers. They are also available in a variety of colours, which serve to compliment any architectural style.

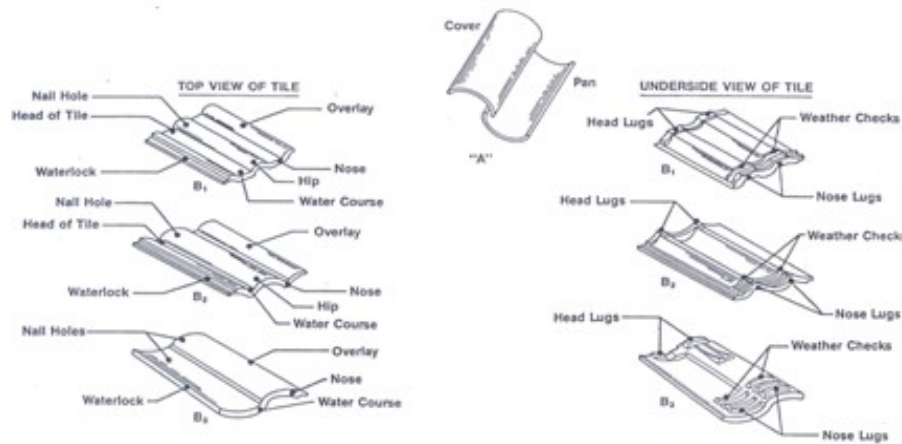

Figure 1-1 Tile parts

Shingle- and slate-like tiles are representative of flat roof tile design. As more restrictions are placed on untreated wood shakes and shingles, architects, builders and roofers are turning to flat shingle tile design or slate style roof tiles. Some of the flat shingle tiles are undistinguishable from wood shingled roofs after they are installed. The appearance of cedar is achieved with the fire-safe and durability features of tile.

### **Standard Tile**

Standard, unglazed clay tiles and concrete roof tiles are produced in British Columbia and Ontario. Modern, high pressure extruded roof tiles will withstand both the highest and lowest temperatures our world has to offer. In most areas, tiles are installed over a single layer of heavy duty underlayment on minimum ½ inch decking.



Figure 1-2 High Profile accessory tiles (A) ridge (B) hip (C) closed ridge end (D) terminal (E) gable terminal.

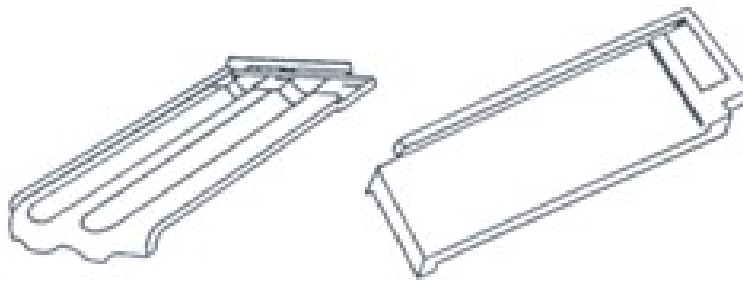

Figure 1-3 Flat tile may be a flat shingle shape or a flat ribbed shape with inter-locking features

### ***Glazed Clay Tile***

Glazes impart on the tile colours and colour effects that cannot be achieved with other methods. Their highly reflective surface imparts a sheen which changes in subtle ways depending on the conditions of the light and the point of view of the observer. This special quality gives the roof endless variety and interest. A full palette of colours and textures ranging from glossy bright reds and vibrant blues to muted matte grays is available from various manufacturers. In addition, the manufacturers are often called upon by the designer or specifier to create tiles in custom colours and special finishes. These custom jobs may be required when the specifier wishes to match the tiles on an existing roof that is being repaired or renovated. Designers will also commonly call upon manufacturers when they wish to create unique tiles to tie the roof into the overall design of the building.

Glazed tile roofs have some performance characteristics that can be important considerations to specifiers. Glazed tile is prized in southern, humid climates for example, because it will discourage mildew and fungus deposits from forming on the roof. Conversely, an unglazed roof tile with a very rough surface texture may promote the growth of the fungus. In an inferior quality roofing tile, this may hasten the deterioration of the roof surface.



Figure 1-4 Oriental Style Glazed Tile

There are advantages as well to glazed tile roofs in northern climates where heavy snow loads are a concern and shedding the snow from the roof is desirable. Glazed tile roofs have a greater tendency to allow the snow to slip off in a sheet than do roof tiles which are unglazed and rough-textured.

For the most part however, the properties of the basic tile are not changed with the added glaze. The glaze does not automatically protect the tile from various weather conditions. In addition, no special packaging or handling is required for glazed tile.

#### ***Application of Glazed Tiles***

Something to watch for when installing glazed tiles are the necessary end cuts. Although accessory tiles can handle many edges, roofers should ask manufacturers for recommendations on touch-up colours to blend the exposed ends of tile with the rest of the roof. When you do cut tile, cutting into the wind is a good idea so that the dust blows off the roof.

#### ***Glazed Tile Costs and Quality***

Glazing can add anywhere from 10% to as much as 400-500% to the cost of a roofing tile, depending on the complexity of the process used. Specifiers pay this premium to get the design effects that cannot be achieved in any other way. The additional expense however, makes it even more important that the glazed be of excellent quality. Failure to carefully control all factors in the process can result in glazed with an imperfect surface, glazes that are not properly bonded to the surface of the tile and glazes that do not give the desired colour effect. Inferior quality glazes can actually contribute to the rapid deterioration of the tile through their failure to shed water properly.

The difference between good and inferior quality glazing work is not always immediately apparent. A sample may be too small or too carefully selected to reveal any of the telltale signs of poor quality glazing work that are not immediately apparent and often develop late in the life of the tile. You should also look closely at the guarantee offered by the manufacturer. Perhaps the most important variable in a guarantee is the number of years the manufacture is willing to stand squarely behind his product. Ask the manufacturer if the appearance of the tile is included in the warranty. The leaders in the tile industry offer guarantees covering their products for as much as 50 years. While this may be more than some owners and specifiers may require, it is an indication of both the quality of the roofing materials and of the likelihood that they will offer superior, low-maintenance performance.

### ***Glaze Formulation - Glazes are really Glass***

A glaze is a surface applied colour in which glasses are formed to achieve a semi-vitreous (glass-like) to vitreous surface on the tile body. Glazed tiles can be made in any colour, shade, hue or intensity that is required. The colour is created by including iron oxides that are known to produce a certain colour at a given firing temperature. By adding combinations of oxides, various colours can be achieved.

Constituent elements in the glaze are usually frits (enamelling and glazing compounds) clays and the oxides used for colouring. Other elements in the formula may be required to assure that the glaze melts at precisely the right time and temperature during the firing process.

The application of the glaze to the tile is done in the early part of the manufacturing process. Glaze can be applied in a variety of ways. Most commonly, however a spray application method is used. Exact temperature control and proper formulation of the elements of the glaze and tile body are the most important considerations in the glazing process.

Both glaze and tile body are chemically and physically changed in the firing process. The glaze material changes as it melts to form glass. Should the glaze melt at too low a temperature, boiling will take place and the surface glass of the finished product will look bubbly and blotchy. If, on the other hand, the glaze is formulated so that it requires a higher temperature to melt than has been achieved in the kiln, imperfect melting will take place and the glass will not form properly producing a product that looks matted, dull and may show a wide an uneven range of colour.

Proper formulation and firing of the glaze is also an extremely important factor in the longevity of the tile. The glaze and the tile begin as two separate entities. During firing, they fuse together in which the glaze forms a tight, glove-like fit over the tile. Tiles can shrink as much as 13% during the firing process. As the elements of the clay body change and shrink in the firing process, the elements of the glaze must change and shrink at a matching rate. If the elements change at different rates, the glaze may either fit too loosely or too tightly.

When the glaze shrinks less than the tile body, the fit will be too loose. The tile will leave the kiln appearing to be in satisfactory condition. After the glazed tile has cooled, however, stresses caused by normal heating and cooling will result in the glaze actually popping off the tile. This separation of glaze and tile may happen shortly after the tile has cooled or at some time after it has been installed on the roof.

When the glaze shrinks more than the tile body, the fit is considered to be under tension. The glaze surface will craze (spider web cracks). Crazing does not normally detract from the product's performance on the roof, but it may detract from the appearance over time. The cracks may pick up dirt and grime reducing their shine and dulling their colour.

The glaze and tile body must also be formulated to match properly in terms of their imperviousness to moisture. The porosity of the clay body and the glaze in a properly designed tile is compatible. The tile, in essence, is able to breathe and shed moisture absorbed from the environment. When this compatibility is not achieved, the tile will trap moisture and tend to break up in freeze-thaw cycles. Improperly designed tile bodies will spall (fracture) underneath the glaze. From outward appearances, the glazed tile roof may look to be in perfect shape. Despite this, the tiles, when lifted, are shown to have spalled, leading to their premature failure.

### ***Concrete Tiles***

Concrete tiles were first introduced in Germany during the mid-1800's. In the early 1900's, when Portland cement became commercially available, European farmers and builders began producing crude, flat or rounded concrete tiles in wooden molds to replace the more expensive and traditional clay

or natural slate roofing materials. The availability of electricity and improved production methods provided the opportunity to produce a better concrete tile in large quantities.

Concrete roofing tile is composed of Portland cement, sand, iron oxide pigments and water in designed proportions which are mixed and usually extruded or compacted in individual molds to form the tile.

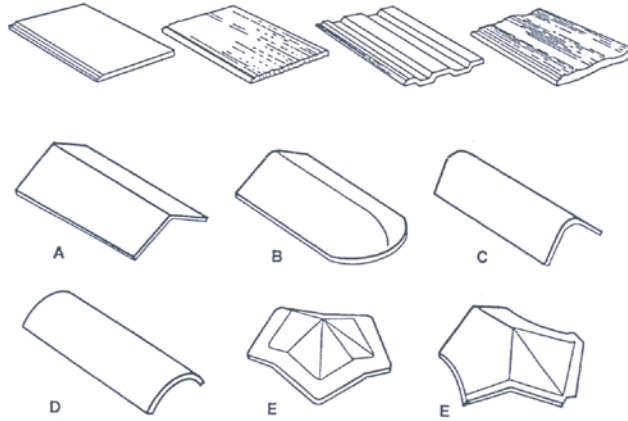
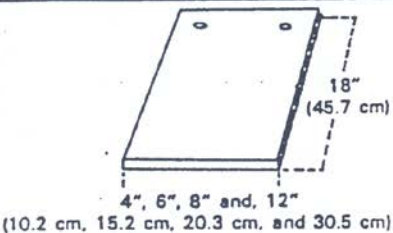

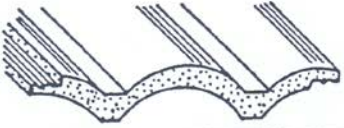
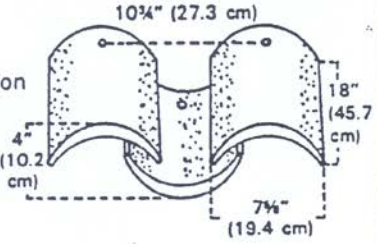
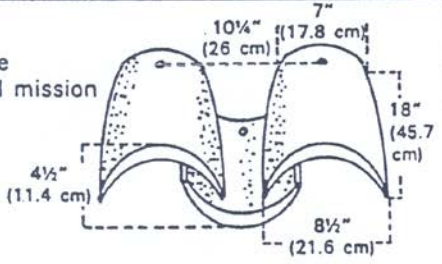

Figure 1-5 Concrete tile types. (A) ridge and hip (B) hip starters or end (C) rake (D) barrel, ridge and hip (E) apexes



Table 1-1 Selected Types of Roofing Tile

Type of tile	Length exposed to weather (regular laying method)	Center-to-center specification	No. of pieces required per square	Average weight per square
Flat shingle 	12" (30.5-cm) widths			
	14" (35.6 cm)	12" (30.5 cm)	86	980 lbs. (444.9 kg)
	Random widths			
	13½" to 15" (34.3 cm to 38.1 cm)	Varies	4"(10.2 cm):12 6"(15.2 cm):26 8"(20.3 cm):26 12"(30.5 cm):52	985 lbs. (447.2 kg)
Flat interlocking 	11" (27.9 cm)	9" (22.9 cm)	150	950 lbs. (431.3 kg)
Sculptured interlocking 	13¼" (33.7 cm)	8¼" (20.6 cm)	90	900 lbs. (408.6 kg)
Two-piece straight mission barrel 	14" (35.6 cm)	10¾" (27.3 cm)	190	1,030 lbs. (467.6 kg)
Two-piece tapered mission barrel 	14" (35.6 cm)	10¾" (27.3 cm)	190	1,150 lbs. (522.1 kg)

**Interlocking Tiles**

Concrete tiles may be classified in two major generic groups: interlocking and non-interlocking. Interlocking tiles, as the name implies, have an interlocking side lap which provides a channel for drainage from the side joint. Interlocking tiles can be used for batten, sealed or hot mop systems. They can be used for steep roof pitches, require less time to install, reduce loose tiles or underlayment slippage, and generally cost less to install. However, these tiles cannot be used on lower sloped roofs in an unsealed system. In the unsealed-batten systems, the roof is not watertight until the tiles are installed and broken or damaged tiles may result in roof leakage.

Probably the most important development in the concrete tile manufacturing process was the high-pressure extrusion process. This technique involves the continuous extrusion of concrete into steel or aluminum molds under high pressure. The resulting product is extremely dense, producing greater strength and minimizing water absorbency exhibiting greater durability in both warm and cold climates.

Concrete tile has a natural reflective characteristic that helps keep the building cooler in summer and warmer in winter. It also improves insulation in a home by creating dead air space below the tile, setting up an effective barrier against heat or cold.

There are two methods for colouring concrete tiles, each producing different effects. Integral colour is a process where iron oxide pigments are added directly to the concrete formula colouring the entire tile all the way through. Colour oxide actually is blended into the sand and cement mixture in varying percentages depending on the colour desired. It is not a colour coating. The other method uses an Acrylic spray technique which is applied to the surface of the tile and has the effect of a high gloss finish referred to as a "whisper luster" and allows for more colour variations in addition to reducing efflorescence, or salt leaching, common to clay and cementitious materials.

Concrete tiles can be extruded into any number of shapes and generally are, simulating everything from wood shakes to clay barrel tiles.

### ***Flashings***

The most common flashing used with roofing tile is prepainted metal flashing steel should be a minimum of 20 ga, Aluminum 20 ga and copper, if used, should be no less than 16 oz per sq. ft.

Lead may also be used where unusual penetrations or design features occur. Improper flashing details and/or installations are the site of most roof failures. Therefore manufacturers should ensure tile installers are properly qualified in the installation of sheet metal flashing.

### ***Fasteners***

Another common cause of failure in a tile roof is found in the incorrect choice of nails. Fasteners must be corrosion resistant because the roof tiles can be expected to last 50 years or longer. Fasteners should provide comparable life expectancy. Most metal nails for installing roof tiles are zinc coated steel, although cadmium plated, stainless steel, brass, copper and other corrosion resistant nails have also been used. Copper nails are recommended. Nails should not be less than No. 11 gauge nails with 5/16" heads.

Nails should not be driven all the way so that they pressure the tile. Proper nailing should bring the nail head close enough to the tile so that the tile essentially is hanging on the nail. Tiles nailed too tightly can crack and fracture. Automatic nailing guns are popularly used on large projects. They can be adjusted to drive each nail to exactly the right depth.

### ***Felts (Underlayments)***

Special care must be given to the selection of the appropriate felt for use as underlayment. Keep in mind that the felt, which serves as both water barrier and cushion, must last for many decades. The felt's function as water barrier is particularly important. While tile very effectively sheds moisture, it is also subject to moisture condensation from underneath. There is a potential for dry rot of the wooden roof substrate if it is not protected. The felt is also the last line of defense from moisture penetration in the event of tile breakage. Felts also serve as a cushion for the tile roof. Tile is non-flexible; in the case of falling tree branched or other pointloading, felts help reduce breakage.

---

## SECTION 4.d ARCHITECTURAL METAL ROOFING

### Introduction

Architectural Metal Roofing Systems that are accepted for use in the RGC Guarantee Program are roll formed, non-structural, hydrokinetic (water-shedding) systems that must be installed over solid roof decks. Although some metal panels may also be designed for use as structural (spanning member) systems, only their use as an architectural metal panel system (over solid deck) is accepted in the RGC Guarantee Program.

Metal roofing panels are roll formed in full rafter length pans that are fastened to decks with metal clips and screws. Galvanized steel and wood are the most common deck materials used with architectural metal roofing.

### Attachment

#### Panel Clips

In-seam (hidden) attachment clips may be a one-piece stationary design that provides a friction fit to the standing seam, which allows unlimited thermal movement of the panel along its length. Alternatively, attachment technology includes built in fastening strips that are formed along the panel seams during the roll forming process and two-piece floating clips that permit a greater range of thermal movement by allowing differential panel movement to take place between the two components of the clip. Only fastening clips that are specifically listed and accepted by the metal panel machine manufacturer are acceptable for use in the RGC Guarantee Program.

#### Drag Load Fasteners

By design most architectural standing seam metal panel systems are intended to float to provide freedom for thermal expansion and contraction. Proprietary attachment clip designs permit metal panels to slide back and forth on the clip as the panel expands and contracts during the thermal cycle. Therefore, metal panels must be pinned to the structure with fasteners to prevent slippage down the roof due to gravity loads or drag loads. Live snow loads can create considerable drag on panels displacing them from their intended location. The most common place to install drag load fasteners (point of fixity) is at the roof ridge, which allows fasteners to be concealed by cap flashing.

Wind Uplift Resistance of Metal Roofing for the simplified procedure for wind design of metal roof assemblies prepared for The Roofing Contractors Association of British Columbia (RCABC) by The National Research Council, Institute in Construction, (NRC/IRC Report No. B1040-3) is provided at the end of this tab section.

### Materials

Portable roll-forming machines for standing seam systems are available for onsite use. Seam spacing can be from 6 to 20 inches. Various seam heights are possible. Rafter length pans can be installed with such equipment. This expedites installation and eliminates transverse seams.

RGC accepted metal panel systems shall be formed of steel conforming to one of the following material specifications, as applicable:

ASTM Standard Specification A653/A653M, Sheet Steel, Zinc-Coated (Galvanized) or Zinc-Iron Alloy Coated (Galvannealed) by the hot dip process, minimum Grade 33, with a design thickness of 24 gauge (.024") or greater and a minimum zinc coating designation Z275 (G-90).

ASTM Standard Specification A792/A792M, Steel Sheet, 55% Aluminum-Zinc Alloy-Coated by the Hot-Dip Process, minimum Grade 33, with a design thickness of 24 gauge (.024") or greater and minimum coating designation AZ150.

The panel manufacturer has the responsibility of designing a panel and fastening system that is capable of providing the load resistance published in their literature. It is important to note that failure to use the specified components of the metal roof system may result in roof failure. When using concealed fasteners to secure panels, compatibility between the clips, fastening screws and panel must be ensured to prevent corrosion and possible roof failure. Systems attached by concealed fasteners use a specialized seaming machine or clip method to complete the application. Although standards, specifications, and technological advances have altered metal fabrication and application techniques, the key to successful metal roof system performance is paying attention to:

- fasteners
- system design for a specific building ( i.e. load calculation, choosing the system to be specified)
- design of supporting members ( i.e. purlins, trusses, substrate)
- underlayment, eave protection, ventilation
- application
- details

**Wind Uplift Standards:**

National Research Council (NRC-CNRC) Report No.B1040 Wind Uplift Resistance of Metal Roofing. The NRC-CNRC Report No. B1040 test results confirm that an acceptable level of wind uplift resistance can be achieved with RGC Accepted Metal Panel Systems on typical roof designs over solid decking for most British Columbia geographical locations.

A simplified design procedure developed by NRC-CNRC for selecting wind pressure calculations for metal roof assemblies by region (location) and building height in the Province of British Columbia is provided at the end of this tab section.

## UNDERLAYMENT/MODIFIED BITUMEN ICE DAM PROTECTION

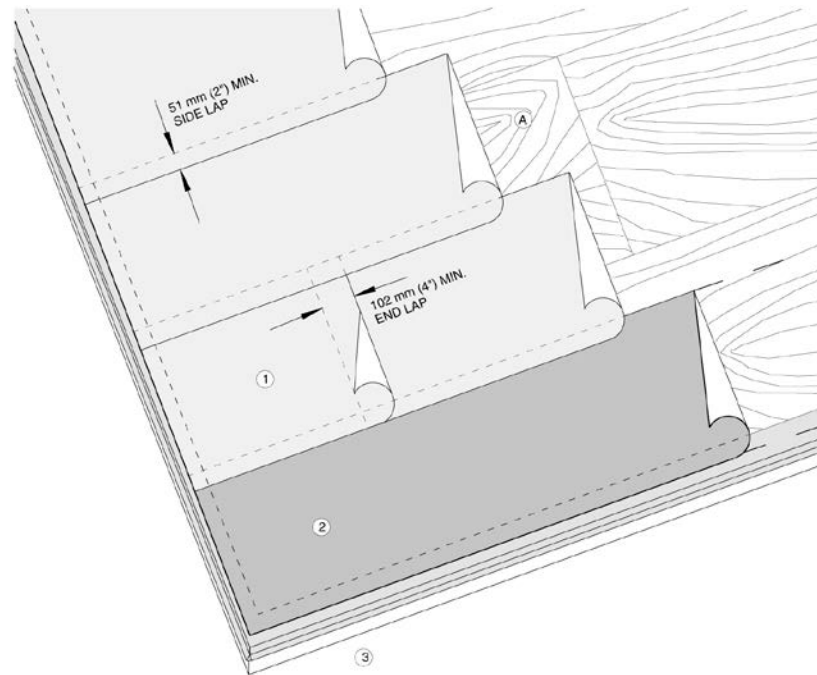

## WORK INCLUDED

1. Underlayment: Proprietary underlayment installed perpendicular to the slope with 50 mm (2") minimum side laps and 100 mm (4") minimum end laps.
2. Ice and Water Protection: One ply of accepted self-adhered modified bituminous membrane.
3. Edge Metal Flashing: Installed to manufacturer's printed instructions.

*Note:*

- This specification is only applicable to slopes 1:3 (4" in 12") or greater
- Slip sheet not shown for clarity

## RELATED WORK BY OTHERS

- A. Acceptable Deck

## MODIFIED BITUMEN UNDERLAYMENT/ICE DAM PROTECTION

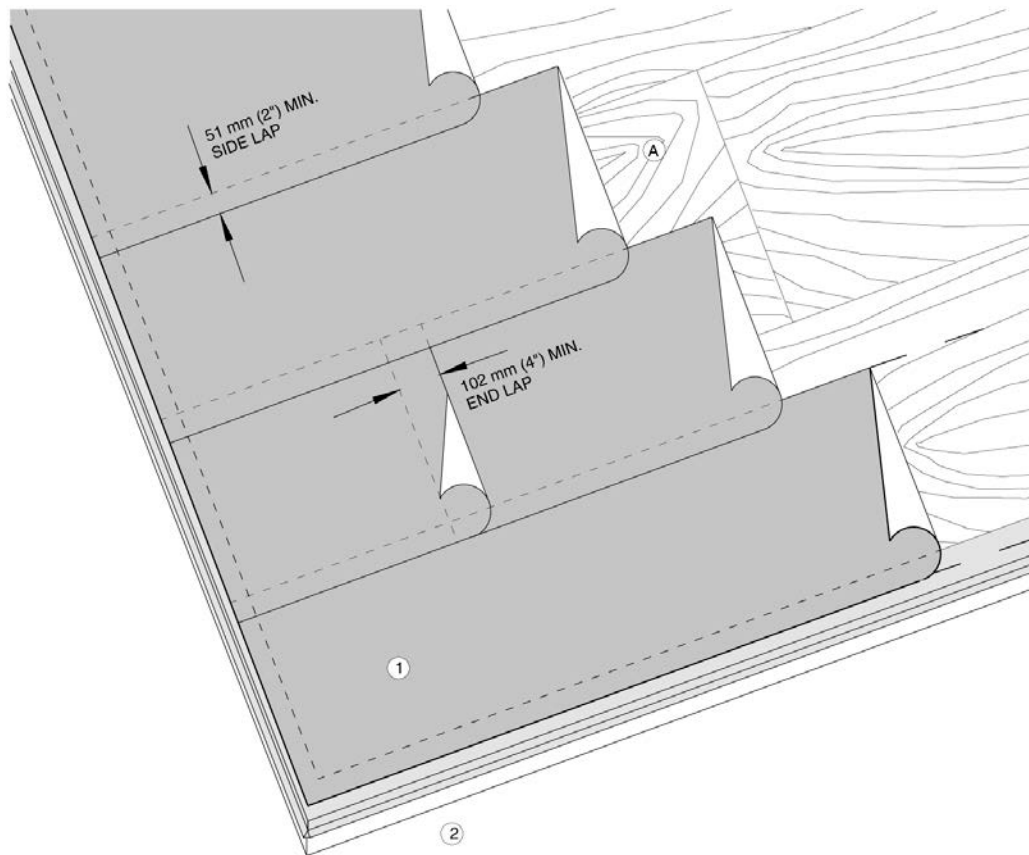

## WORK INCLUDED

1. Underlayment and Eave Protection: One ply of self-adhered modified bituminous underlayment material. Lap 50 mm (2") minimum on sides and 100 mm (4") minimum on ends.
2. Edge Metal Flashing: Installed to manufacturer's printed instructions.  
*Note:* This specification is applicable to slopes 1:6 (2" in 12") and greater.

## RELATED WORK BY OTHERS

- A. Acceptable Deck

## EAVE &amp; GABLE FLASHING FOR STANDING SEAM SYSTEMS

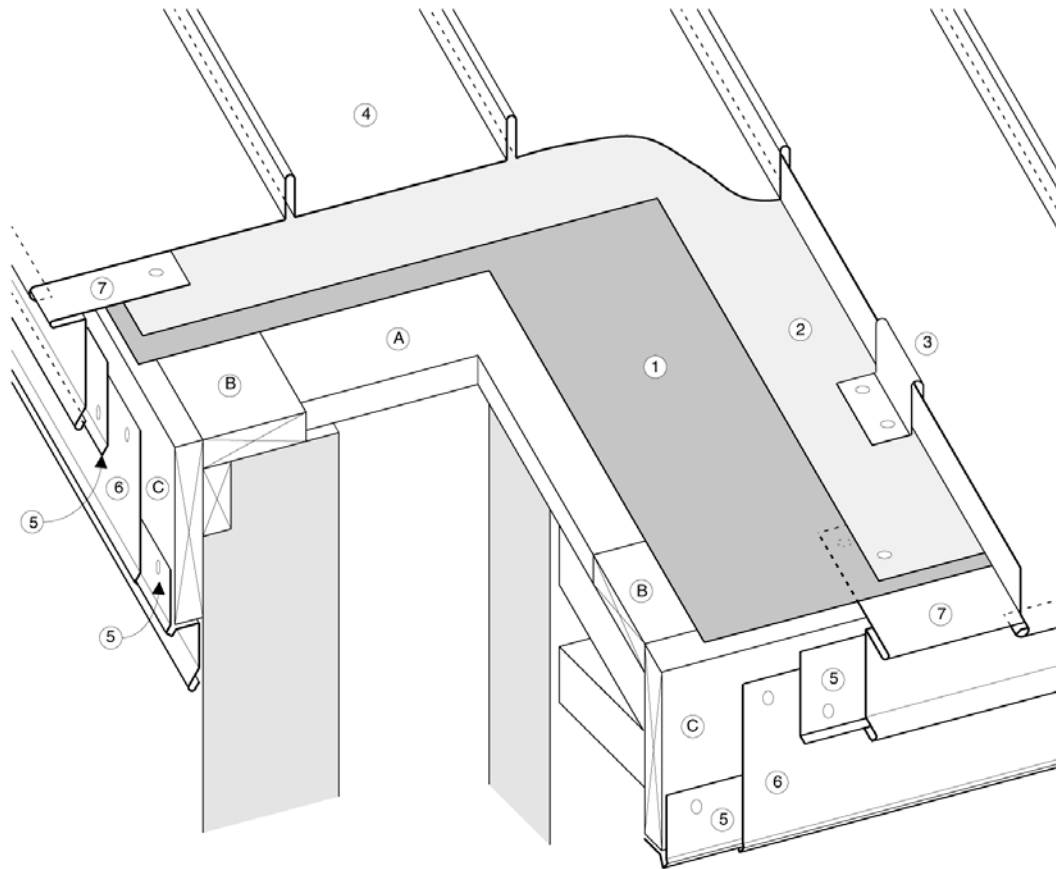

## WORK INCLUDED:

1. Ice Dam Protection: Accepted self-adhered modified bituminous membrane.
2. Slip Sheet: Recommended over asphaltic underlays and/or as required by metal panel manufacturer.
3. Metal Panel Clip: Installed to metal roof panel manufacturer's printed instructions.
4. Architectural Metal Roof Panel
5. Continuous Metal Cleat
6. Metal Fascia Flashing
7. Continuous Edge Metal Flashing

## RELATED WORK BY OTHERS

- A. Acceptable Deck
- B. Wood Nailer
- C. Fascia Board

## EAVE &amp; GABLE PROTECTION FOR PROPRIETARY SYSTEMS

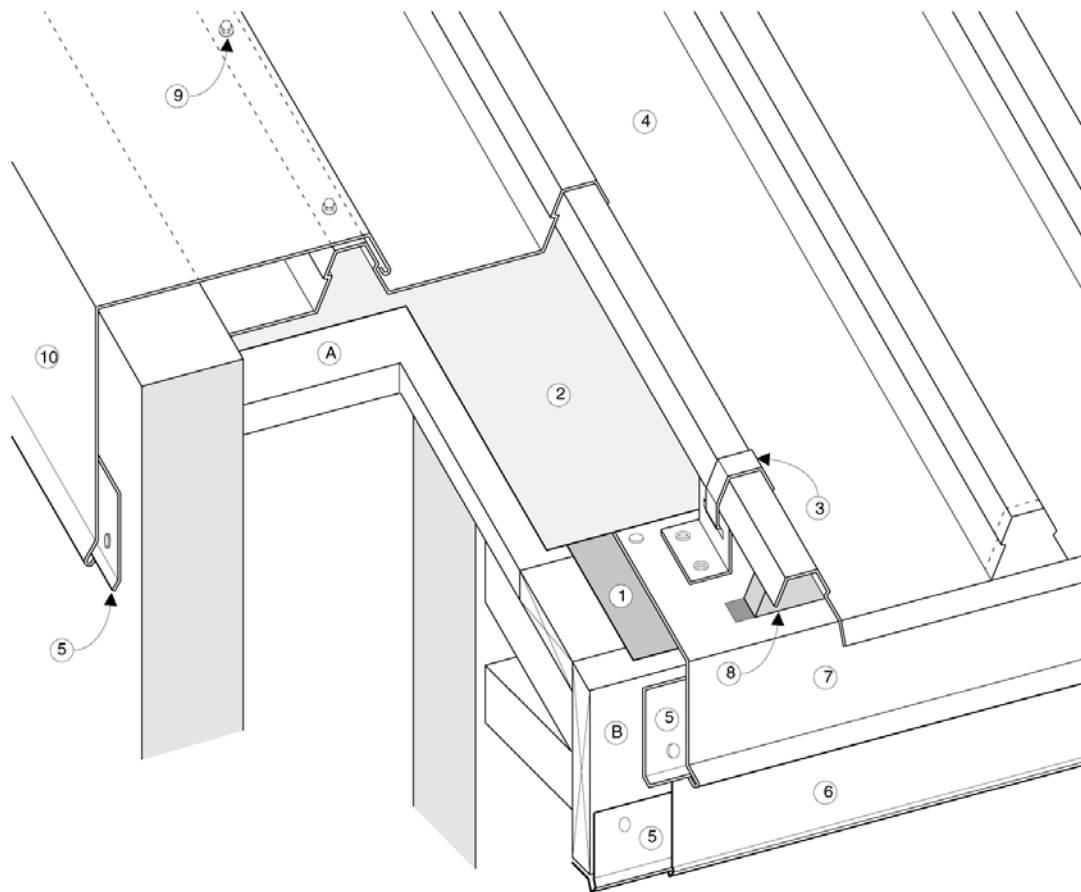

## WORK INCLUDED:

1. Ice Dam Protection: Accepted self-adhered modified bituminous membrane.
2. Slip Sheet: Recommended over asphaltic underlays and/or as required by metal panel manufacturer.
3. Metal Panel Clip: Installed to metal roof panel manufacturer's printed instructions.
4. Architectural Metal Roof Panel
5. Continuous Metal Cleat
6. Metal Fascia Flashing
7. Edge Metal Flashing
8. Preformed Closures
9. Exposed Fasteners: High-domed gasketed cladding type screws compatible with metal roof panel.
10. Rake Edge Metal Flashing

## RELATED WORK BY OTHERS

- A. Acceptable Deck
- B. Fascia Board



## METAL VALLEY - HOOKED FLASHING

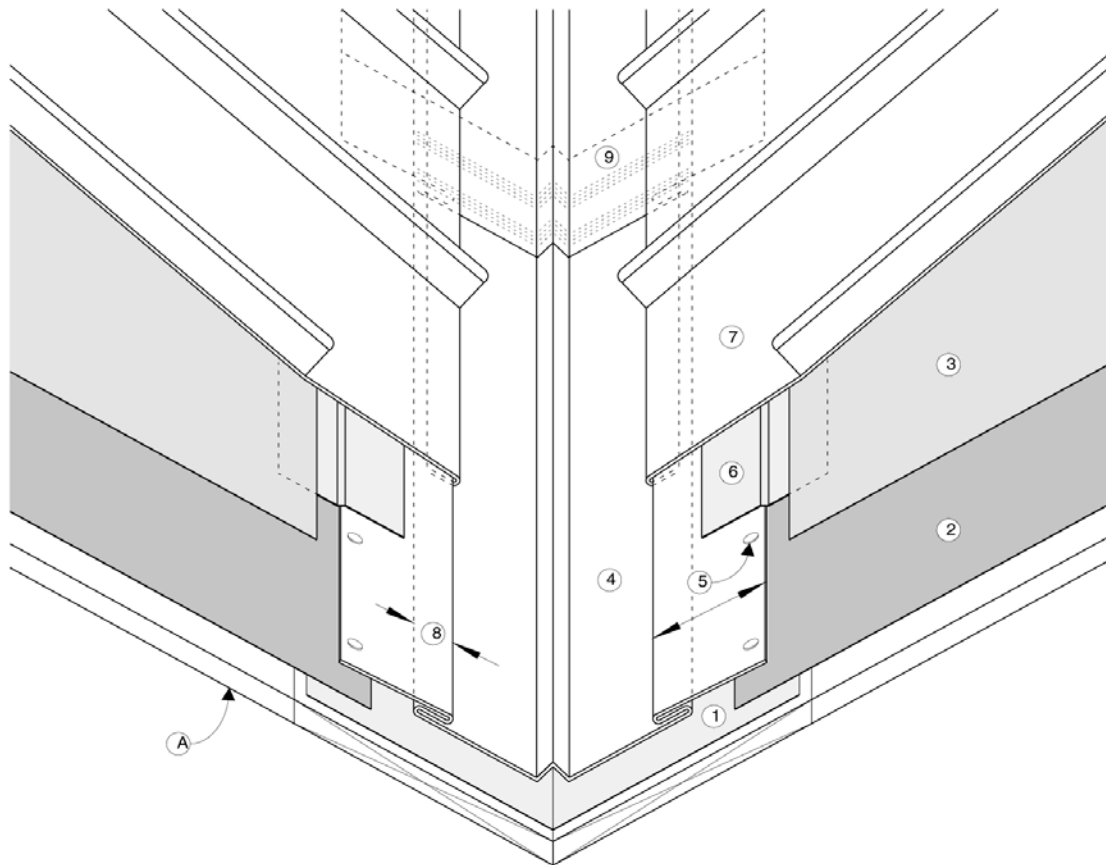

## WORK INCLUDED:

1. Valley Protection Membrane: Accepted self-adhered modified bituminous eave protection membrane.
2. Underlayment: The type of underlay required is determined by roof slope.
3. Slip Sheet: Recommended over asphaltic underlays and/or as required by metal roof panel manufacturer.
4. Valley Metal Panel: Preformed with centre rib and built-in continuous lock.
5. Fastening: Metal valley panels to be secured with compatible, non-corrosive, flat head fasteners 200 mm (8") o/c. Metal roof panel to metal valley panel overlap must be a minimum of 125 mm (5").
6. Membrane Strip-In: Accepted self-adhered modified bituminous eave protection membrane.
7. Architectural Metal Roof Panel
8. Continuous Built-In Hook Strip
9. Valley Panel Overlap: Set in two continuous rows of accepted caulking or sealant tape.

## RELATED WORK BY OTHERS

- A. Acceptable Deck

## METAL VALLEY - UNHOOKED FLASHING

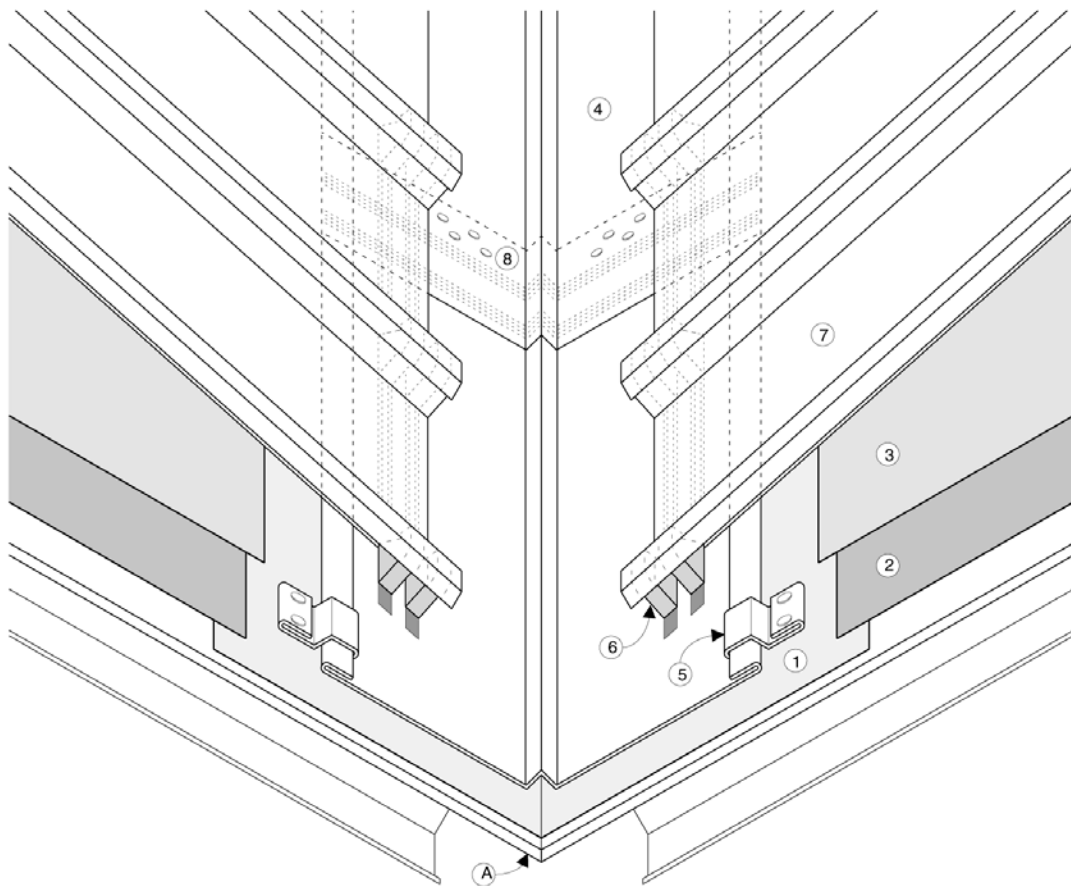

## WORK INCLUDED

1. Valley Protection Membrane: Accepted self-adhered modified bituminous eave protection membrane.
2. Underlayment: The type of underlay required is determined by roof slope.
3. Slip Sheet: Recommended over asphaltic underlays and/or as required by metal roof panel manufacturer.
4. Valley Metal Panel: Preformed with centre rib.
5. Metal Clip: Installed to metal roof panel manufacturer's printed instructions.
6. Pre-Formed Closures: Two rows set in accepted caulking.
7. Architectural Metal Roof Panel
8. Valley Panel Overlap: Overlaps minimum 200 mm (8") sealed with two rows of accepted caulking and drag load fasteners.

## RELATED WORK BY OTHERS

- A. Acceptable Deck

## ROOF TO WALL FLASHING

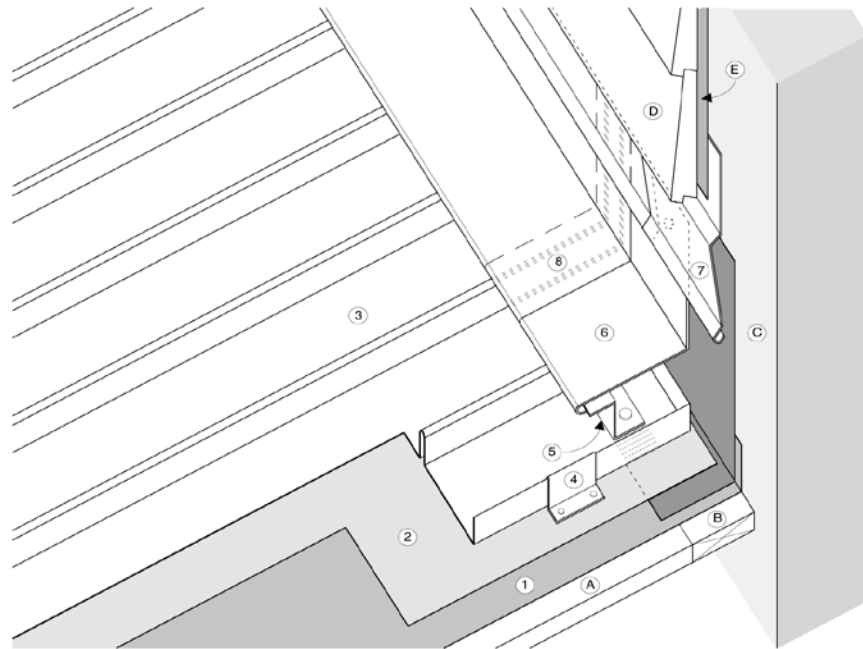

## WORK INCLUDED

1. Underlayment: The type of underlay required is determined by roof slope.
2. Slip Sheet: Recommended over asphaltic underlays and/or as required by metal roof panel manufacturer.
3. Architectural Metal Roof Panel: Turn up (bread panned) at termination and drag load fastened with compatible non-corrosive fasteners.
4. Metal Roof Panel Clip: Installed to metal roof panel manufacturer's printed instructions.
5. 'Z' Closure: Set in accepted caulking and secured with compatible, non-corrosive, flat head fasteners.
6. Sheet Metal Flashing: Hooked to 'Z' closure and fastened to wall with non-corrosive, flat head fasteners 300 mm (12") o/c or preformed foam closures set in acceptable caulking with high domed gasketed cladding type screws at each standing rib.
7. Metal Counter Flashing: Must extend behind siding and building paper. Stucco stops are not considered to be a counter flashing.
8. Overlap: Joints overlapped 100 mm (4") minimum, sealed with two rows of accepted caulking. Exposed edges of joints must be turned under 12.7 mm (1/2").

## RELATED WORK BY OTHERS

- A. Acceptable Deck
- B. Wood Nailer
- C. Wall
- D. Siding
- E. Building Paper

## EQUIPMENT SUPPORT STAND/PIPE FLASHING

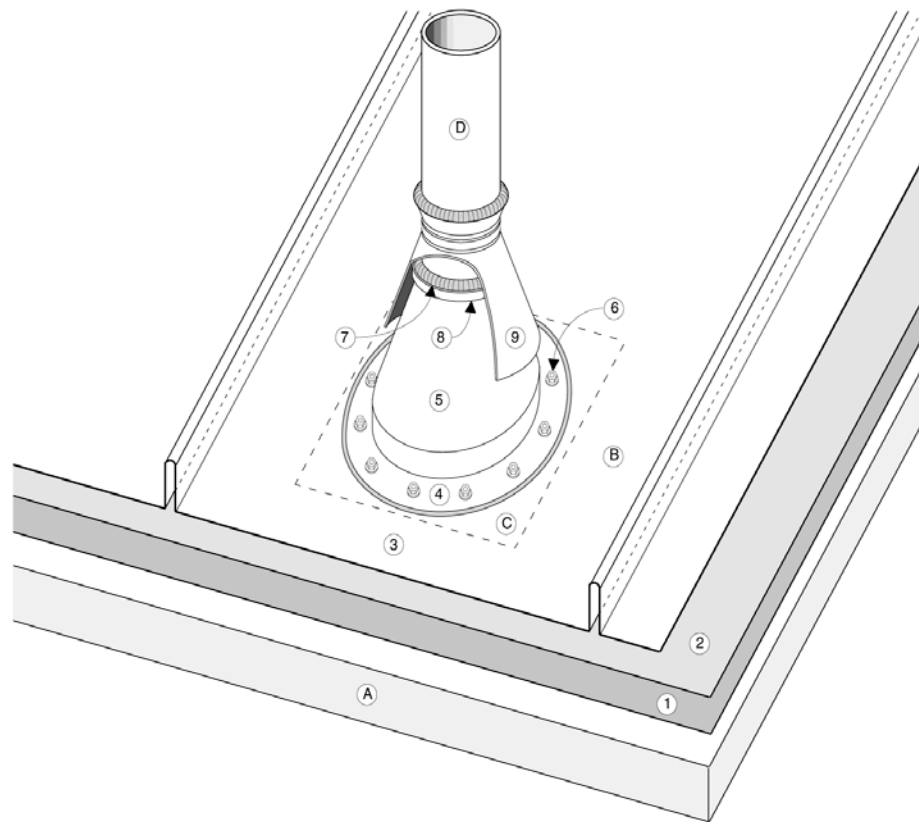

## WORK INCLUDED

1. Underlayment: The type of underlay required is determined by roof slope.
2. Slip Sheet: Recommended over asphaltic underlays and/or as required by metal roof panel manufacturer.
3. Architectural Metal Roof Panel
4. Flange: Set in two continuous beads of accepted caulking.
5. Preformed Penetration Collar
6. High Domed, Gasketed, Cladding Type Screws: Flange fastened to manufacturer's specifications.
7. Seal between Pipe and Flashing: Continuous tooled bead of accepted caulking.
8. Stainless Steel Drawband
9. Water Tight Back Up Storm Collar: Installed where practical.

## RELATED WORK BY OTHERS

- A. Acceptable Deck
- B. Location of Penetrations - must not interfere with standing seams or trapezoidal and intermediate ribs.
- C. Opening in Roof Deck - must be large enough to allow for thermal movement of metal roof panels.
- D. Pipe or Support Stand

## EQUIPMENT SUPPORT STAND, PIPE FLASHING SPLIT PANEL DETAIL

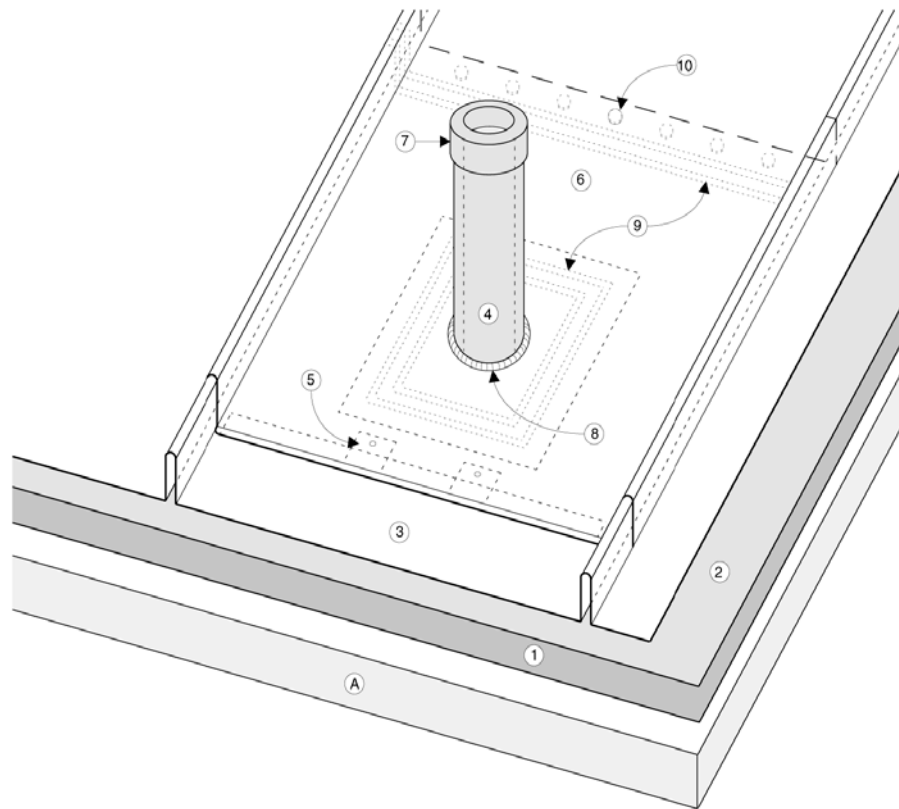

## WORK INCLUDED

1. Underlayment: The type of underlay required is determined by roof slope.
2. Slip Sheet: Recommended over asphaltic underlays and/or as required by metal roof panel manufacturer.
3. Architectural Metal Roof Panel: Lower, installed prior to the pipe flashing, cut hole large enough to allow for movement. Extend 400 mm (16") upslope beyond the pipe.
4. Flashing: Flange set in two continuous beads of accepted caulking.
5. Spaced Cleat: Cleats, set in accepted caulking, spaced 50 mm (2") and fastened with compatible non-corrosive flat head screws.
6. Architectural Metal Roof Panel: Upper, installed after installation of pipe flashing. Cut hole for pipe penetration and turn panel end under to accommodate cleats.
7. Settle Cap: Material must match flashing material.
8. Caulking: Bead of caulking tooled into transition between metal roof panel and flashing.
9. Sealant Tape: Two rows of sealant tape or acceptable caulking.
10. Drag Load Fastening: Compatible non-corrosive fasteners.

## RELATED WORK BY OTHERS

- A. Acceptable Deck

## CURB FOR ROOFTOP EQUIPMENT

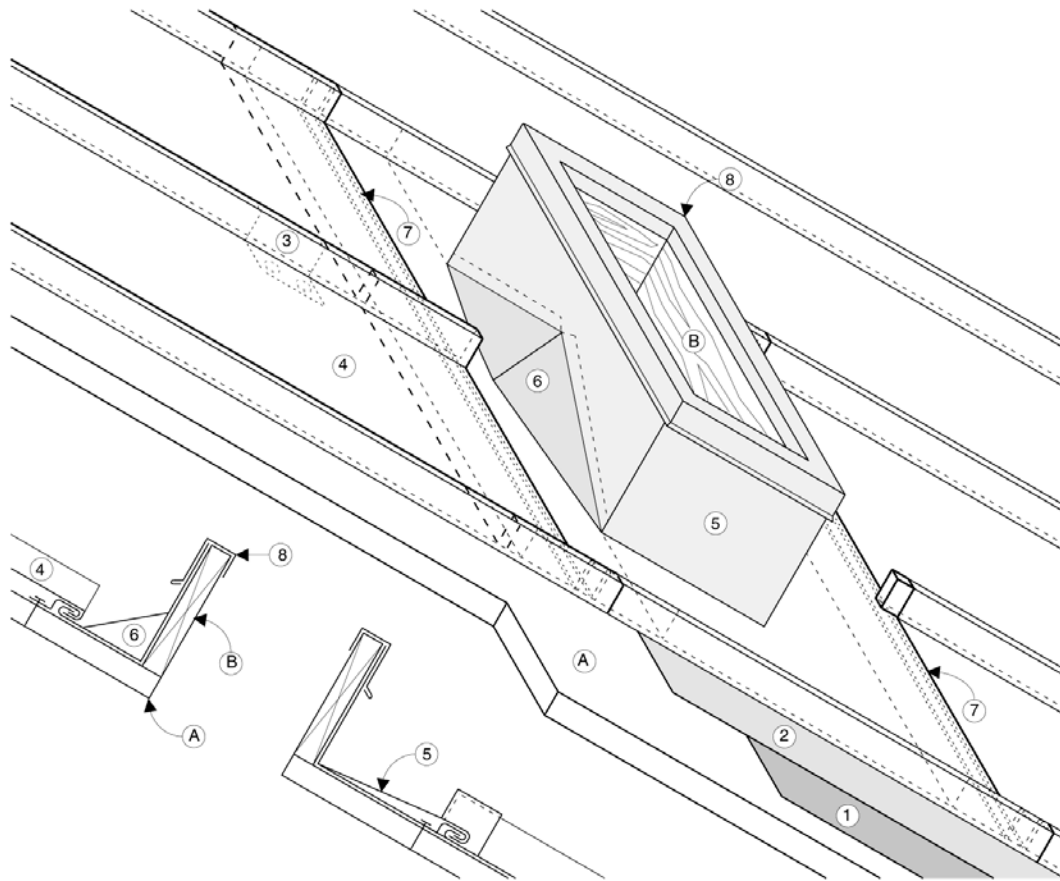

## WORK INCLUDED

1. Underlayment: The type of underlay required is determined by roof slope.
2. Slip Sheet: Recommended over asphaltic underlays and/or as required by metal roof panel manufacturer.
3. Metal Panel Clip: Installed to metal roof panel manufacturer's printed instructions.
4. Architectural Metal Roof Panel
5. Metal Curb Flashing
6. Cricket: Required for curbs more than 900 mm (36") wide
7. Accepted Caulking: Two rows accepted caulking between overlapping sheets, with preformed closures on trapezoidal ribbed roof panels.
8. Counter Flashing

## RELATED WORK BY OTHERS

- A. Acceptable Deck
- B. Wood Curb: 200 mm (8") minimum height

## RIDGE/HIP CAP FLASHING

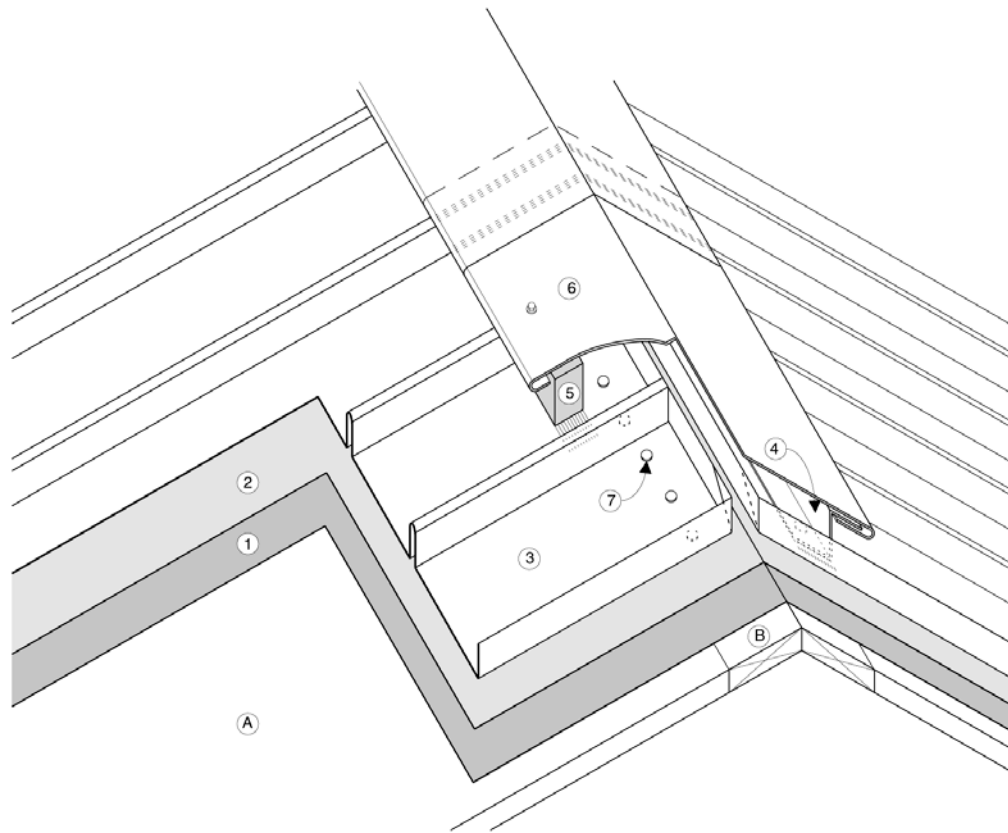

## WORK INCLUDED

1. Underlayment: The type of underlay required is determined by roof slope.
2. Slip Sheet: Recommended over asphaltic underlays and/or as required by metal roof panel manufacturer.
3. Architectural Metal Roof Panel: Turn up (bread panned) at termination and drag load fastened with compatible non-corrosive fasteners.
4. 'Z' Closure: Set in accepted caulking and secured with compatible non-corrosive, flathead fasteners.
5. OR
6. Preformed Foam Closure: Set in accepted caulking.
7. Metal Cap Flashing: Joints overlapped 100 mm (4") minimum, sealed with two rows of accepted caulking. Exposed edges must be turned under 12.7 mm (1/2"). Fastened to each standing seam with high domed gasketed cladding screws or hooked to 'Z' closures.
8. Drag Load Fastening: Compatible non-corrosive fasteners.

## RELATED WORK BY OTHERS

- A. Acceptable Deck
- B. Wood Nailer

## NOTCHED RIDGE/HIP CAP FLASHING

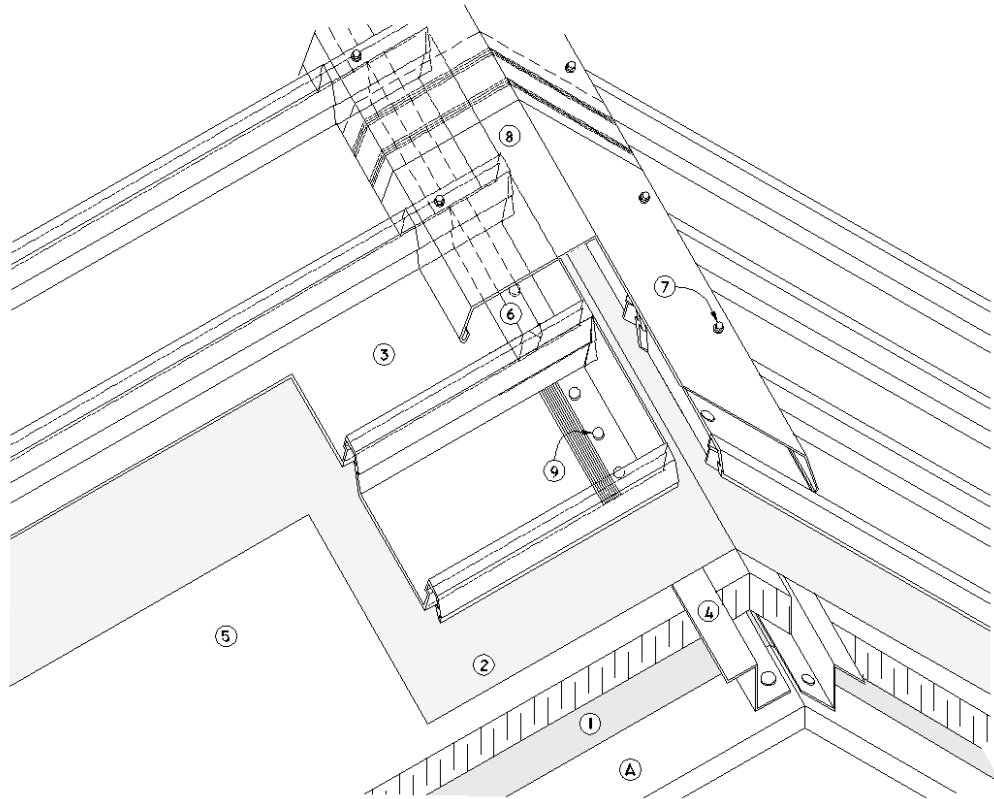

## WORK INCLUDED

1. Underlayment: The type of underlay required is determined by roof slope.
2. Insulation Overlay Protection: Recommended.
3. Architectural Metal Roof Panel: Turn up (bread panned) at termination.
4. 'Z' Bar: Installed to meet adequate attachment for UL I-90 wind uplift requirements.
5. Insulation: Installed between 'Z' bars or wood battens on 600 mm (24") centres.
6. Preformed Foam Closure: Set in accepted caulking.
7. Exposed Fastener: High domed, gasketed cladding type screws compatible with metal roof panel.
8. Metal Cap Flashing: Joints overlapped 100 mm (4") minimum, sealed with two rows of accepted caulking. Exposed edges must be turned under 12.7 mm (1/2").
9. Drag Load Fastening: compatible non-corrosive fasteners.

## RELATED WORK BY OTHERS

- A. Acceptable Deck



## VENTED RIDGE/HIP CAP FLASHING

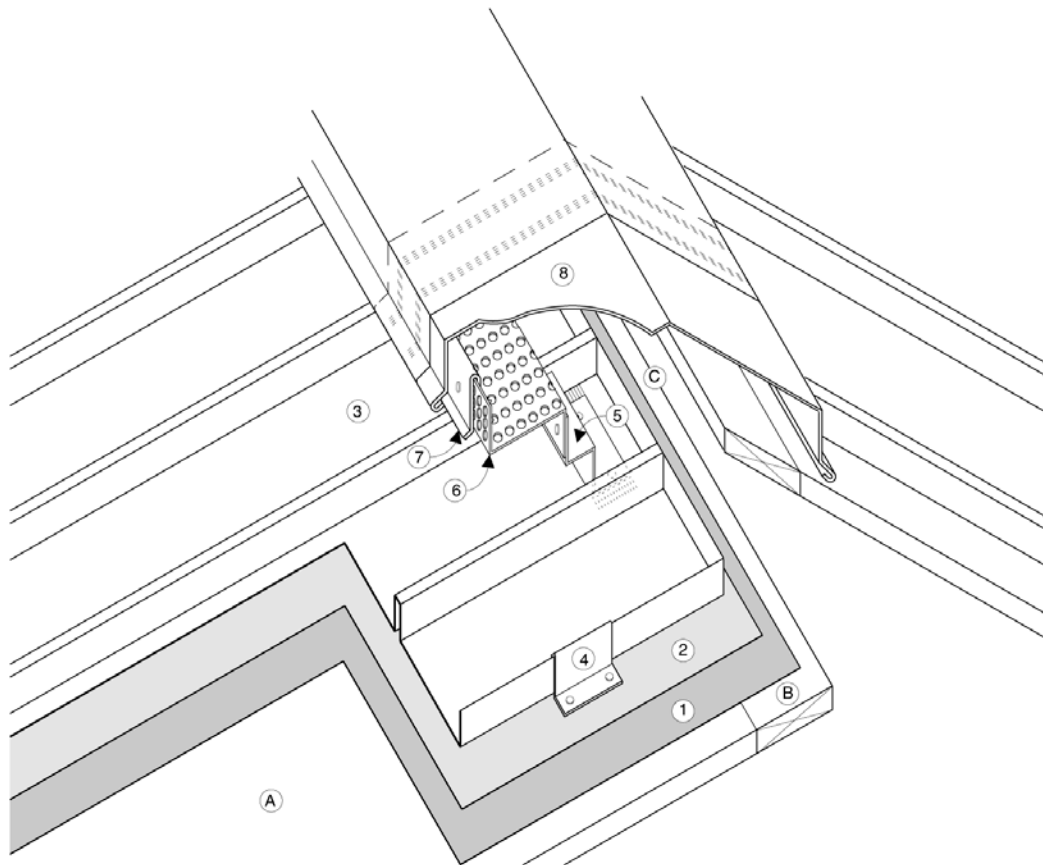

## WORK INCLUDED

1. Underlayment: The type of underlay required is determined by roof slope.
2. Slip Sheet: Recommended over asphaltic underlays and/or as required by metal roof panel manufacturer.
3. Architectural Metal Roof Panel: Turn up (bread panned) at termination and drag load fastened with compatible non-corrosive fasteners.
4. Metal Panel Clip: Installed to metal roof panel manufacturer's printed instructions.
5. 'Z' Closure: Set in accepted caulking and secured with compatible non-corrosive flat head fasteners.
6. Perforated Metal Screen
7. Continuous Cleat
8. Metal Cap Flashing: Joints overlapped 100 mm (4") minimum, sealed with two rows of accepted caulking. Exposed edges must be turned under.

## RELATED WORK BY OTHERS

- A. Acceptable Deck
- B. Wood Nailer
- C. Air Space: Determined by Design Authority.

### PROPRIETARY VENTED RIDGE/HIP CAP FLASHING

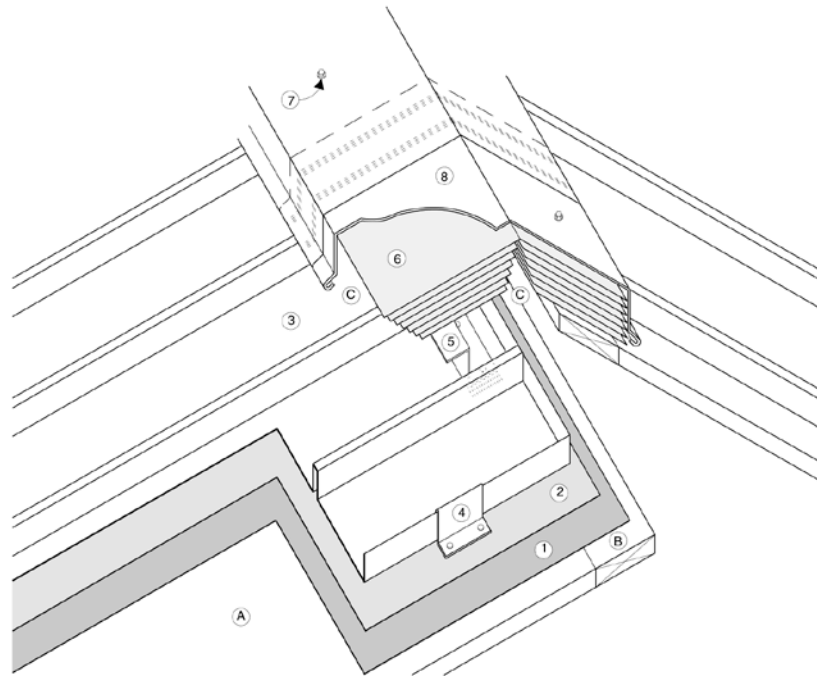

#### WORK INCLUDED

1. Underlayment: The type of underlay required is determined by roof slope.
2. Slip Sheet: Recommended over asphaltic underlays and/or as required by metal roof panel manufacturer.
3. Architectural Metal Roof Panel: Turn up (bread panned) at termination and drag load fastened with compatible non-corrosive fasteners.
4. Metal Panel Clip: Installed to metal roof panel manufacturer's printed instructions.
5. 'Z' Closure: Set in accepted caulking and secured with compatible non-corrosive flat head fasteners.
6. Manufactured plastic louvres
7. Exposed Fastener: High domed, gasketed cladding type screw compatible with metal roof panel.
8. Metal Cap Flashing: Joints overlapped 100 mm (4") minimum, sealed with two rows of accepted caulking. Exposed edges must be turned under.

#### RELATED WORK BY OTHERS

- A. Acceptable Deck
- B. Wood Nailer
- C. Free Vent Area

## PROPRIETARY VENTED WALL FLASHING

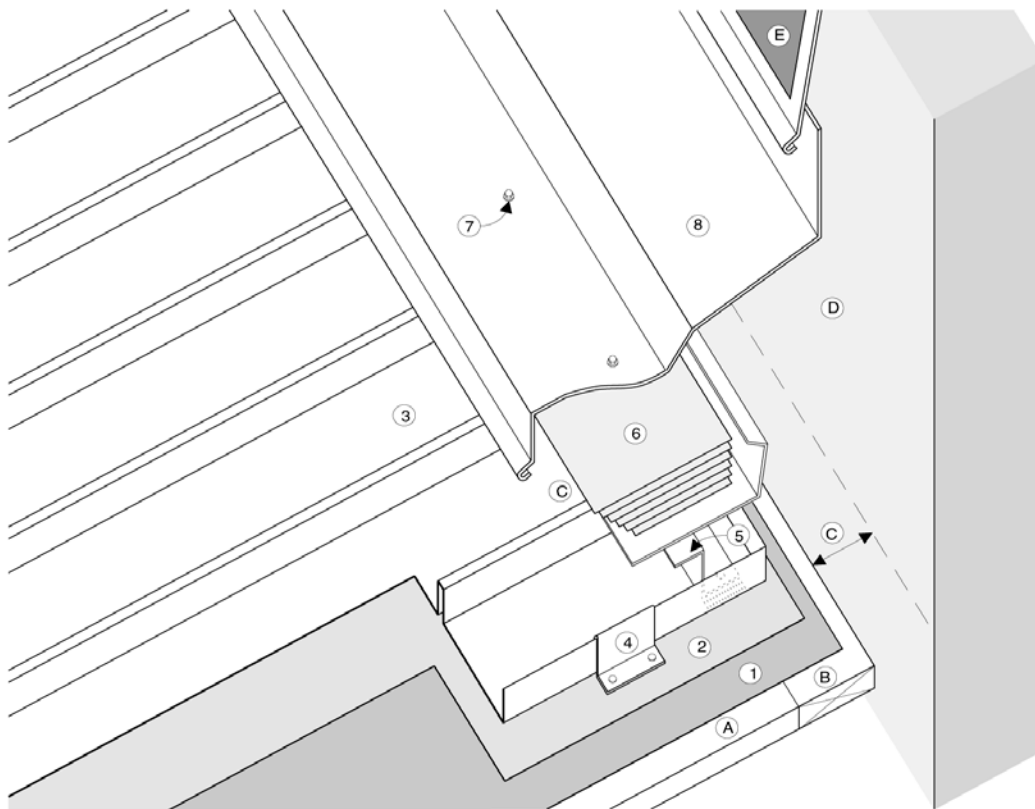

## WORK INCLUDED

1. Underlayment: The type of underlay required is determined by roof slope.
2. Slip Sheet: Recommended over asphaltic underlays and/or as required by metal roof panel manufacturer.
3. Architectural Metal Roof Panel: Turn up (bread panned) at termination.
4. Metal Panel Clip: Installed to metal roof panel manufacturer's printed instructions.
5. 'Z' Closure: Set in accepted caulking and secured with compatible non-corrosive flat head fasteners.
6. Manufactured plastic louvres
7. Exposed Fastener: High domed, gasketed cladding type screw compatible with metal roof panel.
8. Metal Base Flashing: Must extend 200 mm (8") over metal roof panel. Lap joints must be sealed with two rows of accepted caulking. Exposed edges to be turned under.

## RELATED WORK BY OTHERS

- A. Acceptable Deck
- B. Wood Nailer
- C. Free Vent Area
- D. Wall
- E. Building Paper

## **UNDERLAYS FOR METAL ROOFING**

The problems resulting from the presence of condensation represent one of the major causes of damage to the structure and fabric of old and modern buildings alike. They are, therefore, of great importance to the specifier in his design role.

The increased use of insulation and modern roof construction methods have created further major condensation risks within the roof void.

The specifier must ensure that the risk of condensation is minimized by ensuring the correct design, suitable ventilation in accordance with the B.C. Building Code, and specification of the most suitable underlay.

## **WIND UPLIFT RESISTANCE OF METAL ROOFING**

Simplified Design Procedure for Wind Uplift Resistance of Roofing Systems with Metal Coverings

NRC/IRC Client Report No. B1040-3

### ***OBJECTIVE***

To develop a simplified procedure for the wind design of roof assemblies with metal coverings located in the province of British Columbia.

### ***BACKGROUND***

The National Research Council, Institute for Research in Construction (NRC/IRC) was approached by the Roofing Contractors Association of British Columbia (RCABC) to investigate typical 24 Ga metal roof covering systems under dynamic wind load conditions. These investigations were carried out in two Phases.

In Phase I, April 2000, six typical systems with three metal panel products (KR-12, PROLOK and SNAP LOCK 2) were tested with two different deck conditions (air-permeable and airtight). Simulated deck air-leakage ratios, AL (leakage area/deck area), were about 2.42% for air permeable deck conditions and about 0% and 0.05% for airtight deck conditions.

In Phase II, September 2000, four additional systems were investigated with three panels (KR-12, PROLOK and SNAP LOCK 2) configurations with different deck conditions. Simulated deck air-leakage ratios, AL, were about 0% for the airtight deck condition and 0.09% and 0.27% for air permeable deck conditions.

### ***EXPERIMENTAL DATA***

For both Phases, systems were installed at the Dynamic Roofing Facility (DRF) at NRC/IRC and exposed to wind gusts until system failure was observed or maximum load cycle was reached. Details of the experimental setup and collected experiment data were documented under two separate reports as follows:

Wind Uplift Resistance of Metal Roofing System – Phase I by Hee Ham and Bas Baskaran, and

Wind Uplift resistance of Metal Roofing System – Phase II by Hee Ham, Bas Baskaran, and William Lei.

## **SIMPLIFIED DESIGN PROCEDURE**

In this report, a simplified procedure has been developed for designing flat, mono slope and sawtooth roof assemblies with metal coverings located in the province of British Columbia. Designers are directed to use building codes for detailed wind load calculation. This simplified procedure has conservative assumptions, and it is based on the following:

National Building Code of Canada, 1995

Experimental data

Engineering directives, and

Input from RCABC

## **STEP 1 – CALCULATE THE DESIGN WIND PRESSURE**

### Step 1.1

Figure 1 divides the province of British Columbia into three regions:

Region 1 – High wind zone

Region 2 – Moderate wind zone

Region 3 – Low wind zone

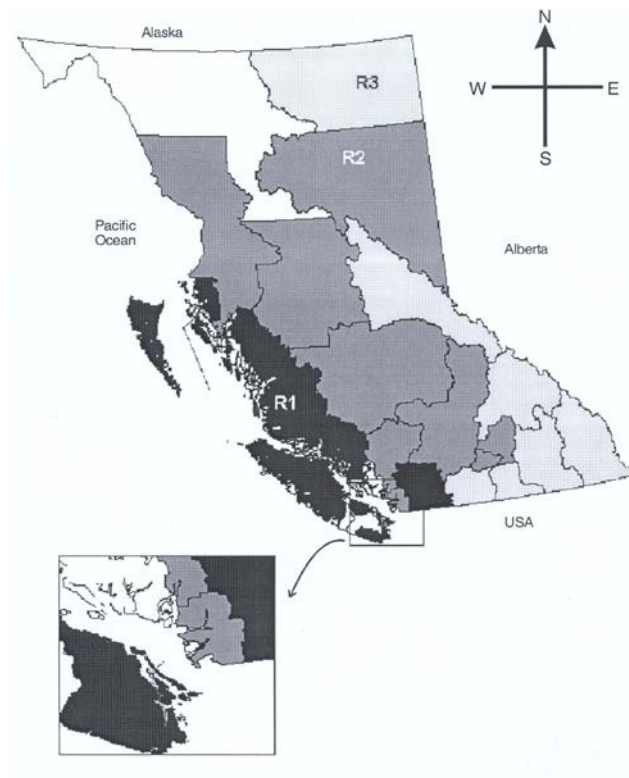

Figure 1. Wind Pressure Zone for the Province of British Columbia

*Note:* it is clear that Region 1 is located near the coast while most of Region 3 is located at the inland area.

Step 1.2

Low-rise buildings with flat roof: For building height less than building width with flat roofs design pressure are given in Table 1. Based on the building height and region, select the design pressure for roof covering design.

Table 1. Flat Roof Cladding Design Pressure

Building Height feet (m)	Region 1 psf (kpa)	Region 11 psf (kpa)	Region 111 psf (kpa)
30 (9.2)	-80 (-3.82)	-57 (-2.72)	-40 (-1.91)
35 (10.7)	-82 (-3.92)	-59 (-2.82)	-42 (-2.01)
40 (12.2)	-84 (-4.02)	-61 (-2.92)	-43 (-2.06)
45 (13.7)	-86 (-4.11)	-62 (-2.96)	-44 (-2.10)
50 (15.3)	-88 (-4.21)	-63 (-3.01)	-45 (-2.15)
55 (16.8)	-90 (-4.30)	-65 (-3.11)	-46 (-2.20)
60 (18.3)	-91 (-4.35)	-66 (-3.15)	-46 (-2.20)
65 (19.8)	-93 (-4.45)	-67 (-3.20)	-47 (-2.25)
70 (21.4)	-94 (-4.49)	-68 (-3.25)	-48 (-2.29)
75 (22.9)	-96 (-4.59)	-69 (-3.30)	-49 (-2.34)
80 (24.4)	-97 (-4.64)	-70 (-3.35)	-49 (-2.34)
85 (25.9)	-98 (-4.68)	-70 (-3.35)	-50 (-2.39)
90 (27.5)	-99 (-4.73)	-71 (-3.39)	-50 (-2.39)
95 (29.0)	-100 (-4.78)	-72 (-3.44)	-51 (-2.44)
100 (30.5)	-101 (-4.83)	-73 (-3.39)	-51 (-2.44)

Step 1.3

Low-rise buildings with mono slope roof: For building height less than building width with roof slopes that are greater than 3° and less than 10°:

$$\text{Design Pressure} = 0.90 \times \text{Design pressure reported in Table 1.}$$

Step 1.4

Low-rise buildings with sawtooth roof: For building height less than building width with the roof slopes that are greater than 10° and less than 30°:

$$\text{Design Pressure} = 1.34 \times \text{Design Pressure reported in Table 1.}$$

Step 1.5

Medium rise buildings with flat roof: For building height greater than building width:

$$\text{Design Pressure} = 1.05 \times \text{Design Pressure reported in Table 1.}$$

## Step 1.6

Wind Uplift Pressure = Design Pressure X Factor of Safety.

NBC, 1995 recommends minimum design values. Selecting an appropriate factor of safety depends on the designer, and it should be 1.0 or higher.

**STEP 2 – REDUCTION FACTOR CALCULATION FOR AIR PERMEABLE DECK CONSTRUCTIONS**

When deck construction permits air to pass through openings or joints (leakage), there will be a significant reduction in the wind uplift resistance of the roof covering. One can minimize this effect by using an air barrier that is adhered to the deck prior to the installation of the covering and by sealing perimeters, penetrations and junction flashing. Some air permeable deck constructions include the following:

- reroofing applications
- acoustical steel decking
- unblocked (or) non-tongue and grooved wood decking
- precast concrete and gypsum planks without grouted joints
- cementitious wood fibre planks.

## Step 2.1

Calculate the ratio of leakage area by using the following formula:

$$AL = \{\text{Leakage area/Deck area}\} * 100, \%$$

For example, convention deck constructions, i.e., new 5/8" (16mm) tongue and groove plywood has AL  $\equiv$  0%, and for 1/2" (13mm) plywood installed with H clips AL can be varied based on roof dimension, number of boards used, and clip locations. A sample calculation is shown in Appendix 1.

## Step 2.2

Using Figure 2, quantify a reduction factor that can account for the air permeable deck constructions. The horizontal axis shows the AL in percentage and the vertical axis displays the reduction factors. The selected reduction factor should fulfill the following criteria:

$$\text{Reduction Factor} \leq 1.0$$

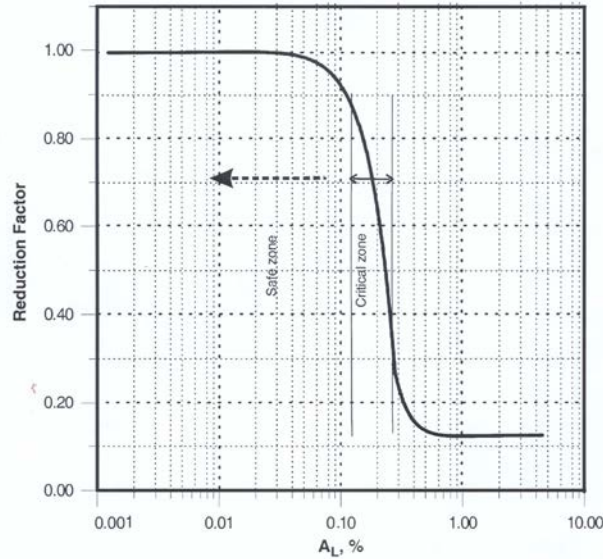

Figure 2. Reduction Factor vs. Air Leakage Ratio, AL

Note 1: These reduction factors were developed based on limited experimental data.

Note 2: It can be observed that the resistant wind pressure is increasing dramatically as the air leakage ratio is decreasing. It can also be estimated that a critical zone exists between  $0.12\% \leq AL \leq 0.27\%$

### STEP 3 – IDENTIFYING A SUITABLE PANEL CONFIGURATION

Using Figure 3, select a panel configuration and its wind uplift rating. This rating represents a conservative scenario of metal coverings installed over airtight deck configuration. Therefore, calculate the actual wind uplift resistance as follows:

Wind Uplift Resistance = Panel Wind Rating X Reduction Factor

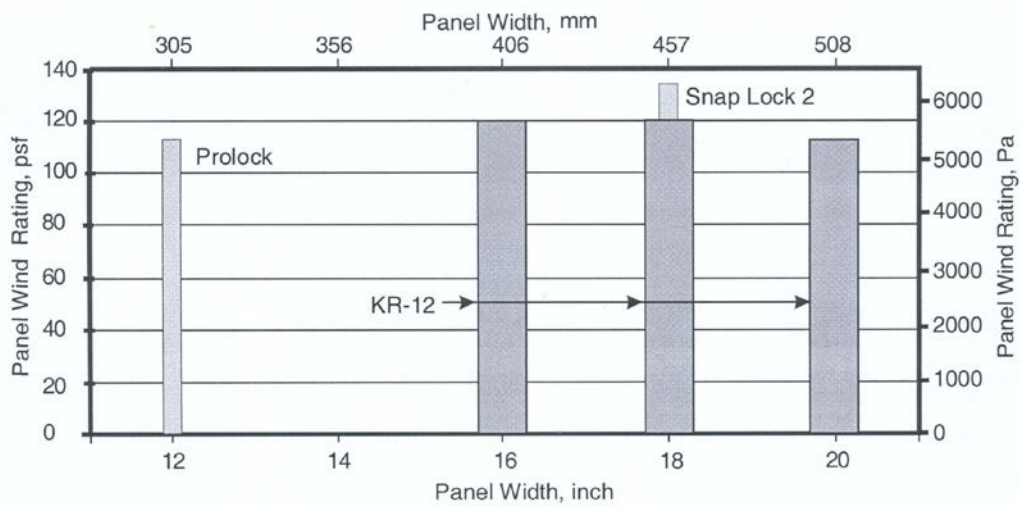

Figure 3. Wind Rating vs. Panel Width



**APPENDIX 1 – SAMPLE CALCULATION FOR AL**

A typical calculation of AL is shown for the 1/2" (13mm) plywood deck with H clips. For a low-rise square or rectangular shape commercial construction, deck layout patterns are shown in Figure A1. Nominal gap for plywood joints is assumed to be 0.08" (2mm). The joists – plywood junctions and flashing edges are assumed to be air sealed. Based on the roof geometry, one can select the appropriate AL from Figure A2. This can be used for the calculation of reduction factors as specified in Step 2.2.

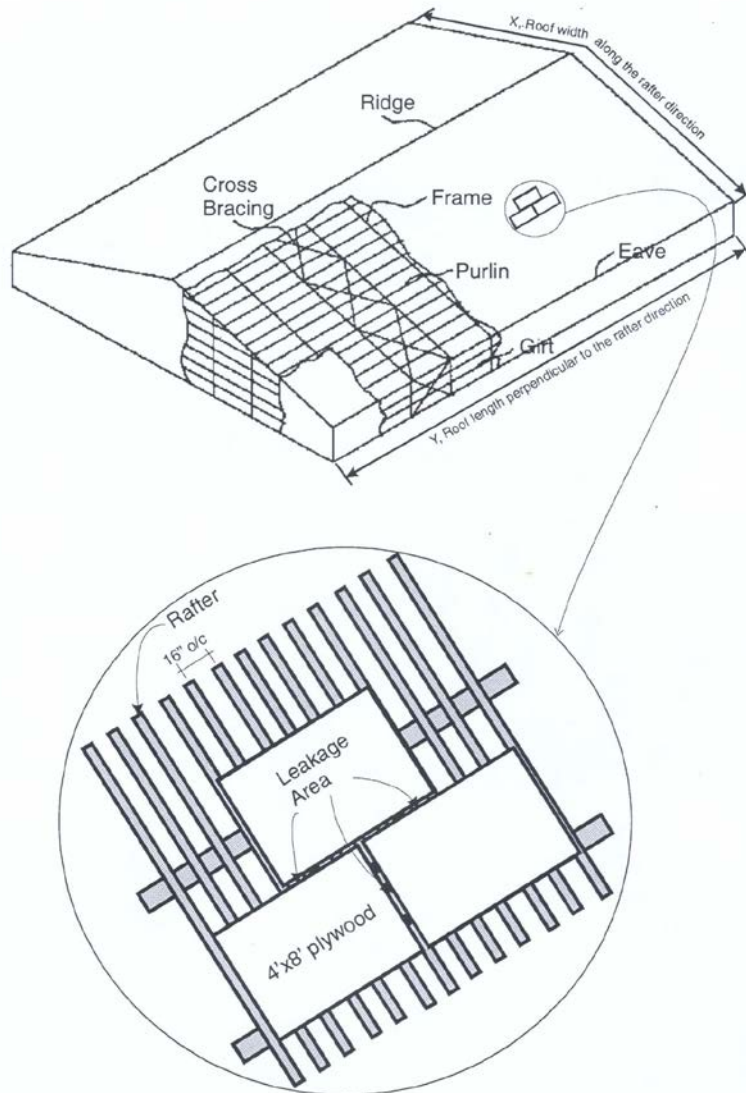

Figure A1. Source of air leakage for plywood decking with H clip installation.

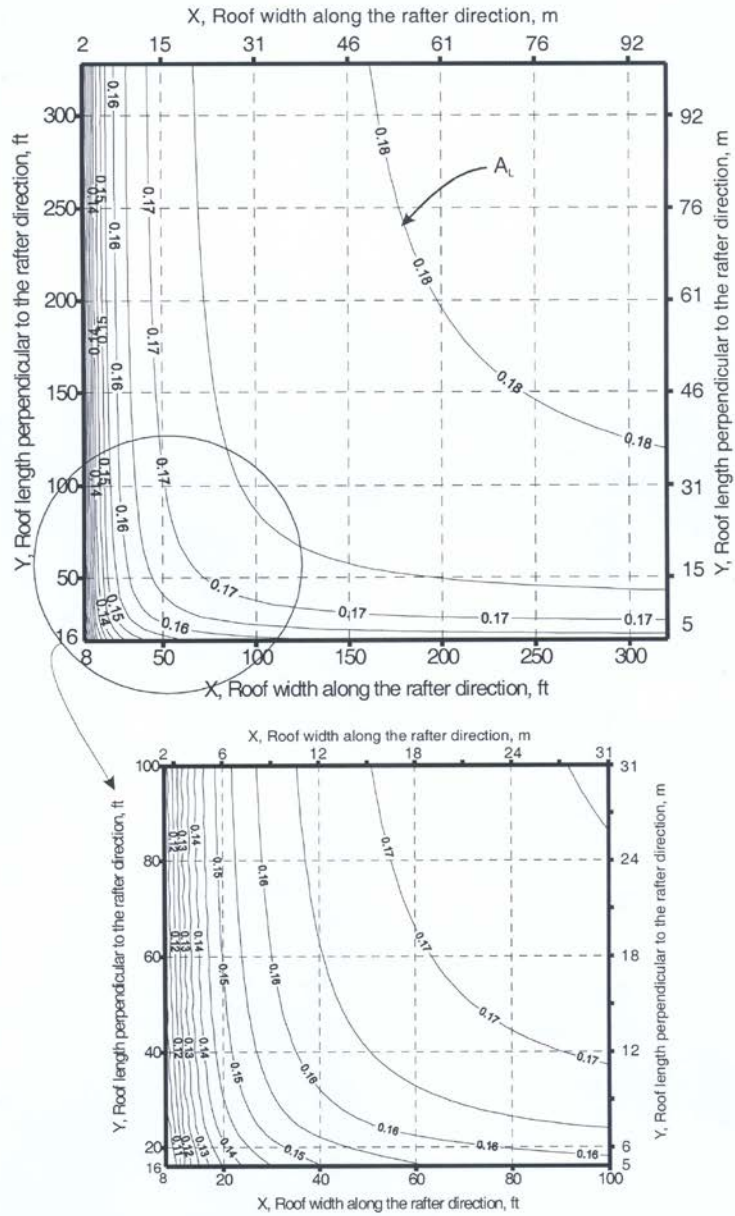

Figure A2. AL for 1/2" (13mm) plywood deck with H clip installation.

## APPENDIX II – OTHER CONSIDERATIONS

### Air Leakage of the deck

Wind uplift resistance of the tested systems increased dramatically as the air leakage ratio decreased. Therefore, one should use caution in using Figure 2.

### Roof construction with building height greater than 100' (31m)

Wind speed increases logarithmically from the ground to the height of the free stream in the atmospheric boundary layer. The obtained result can be applied for low and medium rise buildings (under 100' [31m]). It is not recommended to use the simplified procedure for high rise buildings (exceeding 100' [31m]).

### Roof construction with unique terrain surroundings

The intensifying effects of valleys and other terrain features on wind pressure were not considered in the above procedure.

### Wooden deck span requirement

Spacing of the joists should not be larger than 16" (406mm) for 1/2" (13mm) plywood decking with H clips and 24" (243mm) for 5/8" (16mm) tongue and grooved decking.

### Eaves, overhangs and canopies

Eaves, overhangs, canopies, and nearby areas, by their design, may be subject to greater uplift forces than the roof surface because of pressure differential. These effects should be considered.

### Edge conditions

The use of parapets of insufficient height, typically lower than two feet, may increase the effect of wind on the roofing system. The specific influence of parapet height on wind design should be considered.

### Panel configuration

Experimental data indicate that systems with Prolock and Snap Lock panels exhibit higher wind uplift stability compared to systems with KR-12 panels. The higher stability may be attributed to the locking mechanism at the seam. Systems with Prolock and Snap Lock 2 panels were locked down lower on the seam giving lower pivot points than those systems with the KR-12 panel.

### Panel thickness

The uplift resistance is not only a function of air permeability of the deck and spacing of joists and pullout value of the fastener but also a function of the properties of metal panels such as thickness and elastic and plastic strengths. The obtained results can be applied to 24 Ga or higher thickness (e.g., 20 Ga) metal roof covering systems. Using these results is not recommended for metal roof covering systems with lower thickness (e.g., 26 Ga).

## BUILT IN GUTTERS FOR WATER SHEDDING ROOFS

### Application Details

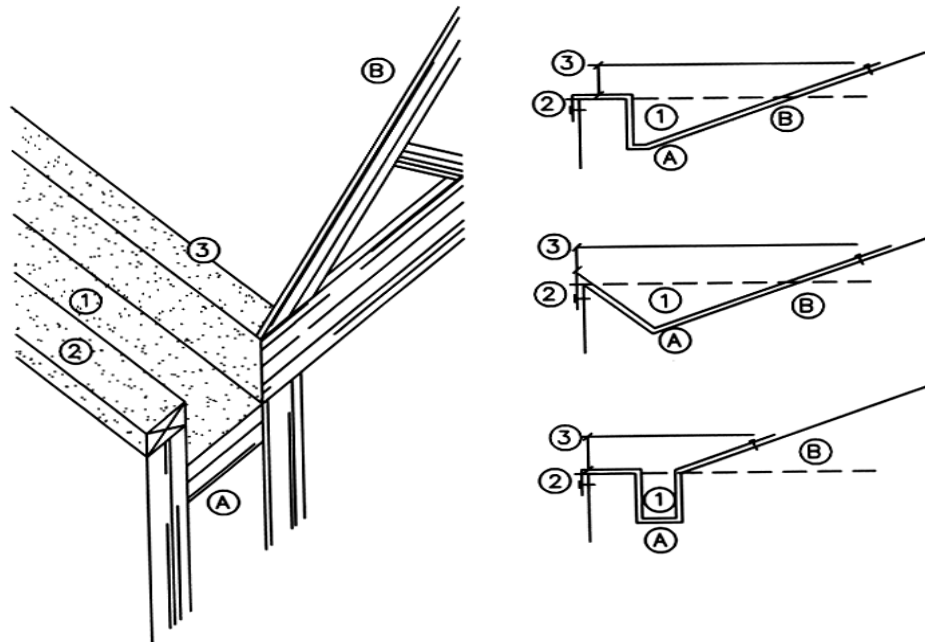

#### WORK INCLUDED

1. **MEMBRANES:** Membranes must be installed to RGC Guarantee Standards and the manufacturer's printed instructions
2. **ADHESION:** Membranes must be fully adhered, where exposed, and mechanically fastened at terminations 300 mm (12") o/c
3. **HEIGHT:** The minimum vertical sealed height above the maximum water level is 150 mm (6"). The membrane run up the slope will vary with roof pitch. Increase height in heavy snow regions.
4. **EAVE PROTECTION:** Built-in gutter membranes can be extended to act as an eave protection membrane. Underlay or eave protection membrane must overlap built-in gutter membrane by a minimum of 200 mm (8") and be installed in shingle fashion (not shown for clarity).

#### RELATED WORK BY OTHERS

- A. **DIMENSIONS:** Dimensions of parapets, cants and water loading of gutters are variable and should be determined by design authority
- B. **ACCEPTABLE DECK**

## SECTION 4.e METAL ROOFING TILES

Metal tiles offer the textured appearance of a traditional wood shake or concrete/clay tile roof combined with the durability of steel. The tiles are protected with a sacrificial metal coating and then finished with either a multi-layered paint and stone chip finish or a paint system. The finished surface, colour, and style vary with the manufacturer.

A high quality metal tile, properly installed on sufficient slope, can provide a strong and light weight roofing system offering low maintenance, high resistance to deterioration, and versatile configurations.

---

## SECTION 4.f BUILT-UP ROOFING (BUR/TAR & GRAVEL)

Built-up or multi-ply, roofs (BUR) offer additional layers of protection against moisture penetration. This feature makes BUR an excellent waterproofing system. Its many years of use, and well known "track record," have made it the "traditional" roofing material.

### COMPONENTS OF A BUR

- A. Vapour retarder, if specified
- B. Insulation
- C. Base sheet, if specified
- D. Felt plies and bitumen as specified
- E. Flood coat, cap sheet, or aggregate as specified

### Roofing Felts

In the construction of a BUR, the felts act as reinforcement for the thin layers of bitumen. The bitumen is the actual waterproofing agent. These alternating strata of material form the BUR membrane. There are several choices of available felt materials, the most common of which are described in the following paragraphs.

#### Asbestos

Asphalt-saturated 15 lb. asbestos fibre felt is an organic felt that has been used extensively in smooth surface applications. It was once the most popular felt material. However, asbestos felt is no longer used for two reasons: its low tensile strength, and its hazardous effects on human health. In fact, asbestos is being removed from buildings under the direction of the Environmental Protection Agency — either by roofing contractors or by asbestos abatement contractors, at great expense to owners.

#### Glass Fibre

For a long time, the "workhorse" felt of the industry was 15 lb. (now referred to as #15) organic (rag/paper) saturated felt. Saturated felt is by far the most common felt used in Canada. Whereas the U.S. has gone to glass felt, the abundant availability and comparable performance characteristics of saturated felt has maintained it as the primary felt material in a BUR. Glass fibre felt is available as either ASTM Type IV chopped strand saturated felts, or continuous strand, premium grades, with higher tensile strength. Type VI felt, with even better performance than premium grade, is also available.

However, since splitting is rare in Type IV glass fibre felts, and they work well with the available bitumens, the proprietary Type VI felts have only a limited market.

In the U.S., the increased use of glass fibre felts (which represent 92% of all felt currently used there) has reduced the incidence of blistering, ridging, and splitting. Blistering has diminished because glass

felts are more porous, allowing moisture to "percolate" up through the felt. Fewer splits occur because of glass fibre's higher strength in both lateral and longitudinal directions. Of course, when improperly installed, channels, voids, and "fishmouths" can still compromise the system. Some bitumens may not be compatible with asphalt-saturated glass fibre felts. For example, there is growing evidence that non-fuming coal tar pitch (Type IV) may be incompatible with glass fibre felts, causing migration of the bitumen from between the felt plies.

Installers should generally stay off a roof until the asphalt has set. This is especially true when glass fibre felts are used. Otherwise, foot or wheel traffic will squeeze the asphalt from between the plies, creating voids.

**Base Sheets** – A base sheet is composed of either an organic or glass fibre core saturated and coated with bitumen. It weighs between 35 and 43 pounds per 100 square feet, depending upon the core material used.

### **Organic (Cellulose) Felt**

No. 15 consists of cellulose (wood fibre) partially saturated with asphalt. When it is applied to the roof and fully saturated, the fibres provide the structural strength for the roof membrane to resist the effects of thermal cycling. They serve much the same purpose as the rebar in a reinforced concrete structure. Because the felts must be delivered undersaturated in order to absorb asphalt during application, they can also absorb moisture. In storage on the job site, they should be kept covered at all times with a tarp or a sheet of polyethylene plastic.

Felt intended for use with hot asphalt is perforated to permit the escape of gases trapped below the felt layers during application. If the felt is not perforated, it is not intended for use in built-up roofing.

At present, a roll of roofing felt consists of 432 sq ft, which is sufficient to cover four roof squares with one ply (4 x 100 sq ft), or one square with four plies. The extra 32 sq ft is an allowance of 8 sq ft per roof square for lapping. Each roll of felt weighs approximately 60 pounds. Since the roll covers four roof squares, each square of felt weighs 15 pounds — hence the designation "No. 15 felt", previously referred to as 15# felt or 15lb. felt.

### **Polyester Mat**

Another felt material, now used in traditional BUR's, is the polyester mat. Its strength is superior to that of glass fibre felts and it is compatible with both hot bitumens and cold adhesives. Polyester mat is used primarily in the manufacture of modified bitumen membranes.

### **Some Questions and Answers on Glass Felts**

*What is the difference between an organic felt and a glass felt?*

An organic felt, for example No. 15 Asphalt Felt, is typically made with what's called 27 lb basis weight felt (27 lbs/480 ft<sup>2</sup>) and saturated with asphalt, then perforated before winding. The perforations are really tiny flaps pointed upwards, designed to enhance the bond and minimize blistering. Conversely, a glass felt is made with a fibreglass reinforcement, usually 2 lb mat (2 lbs/100ft<sup>2</sup>), and then impregnated with asphalt. The term "impregnation" is used because the tiny glass filaments do not actually absorb asphalt; instead, the asphalt is pushed between them. Glass felts do not need to be perforated because they are porous; in other words, you can hold them up to the light and see through (porosity).

What are the advantages of glass felts?

Glass fibre BUR's have three basic advantages over organic BURs:

1. Glass fibre is inorganic; in other words, it will not absorb water and start to rot. If a leak develops, less moisture damage to the membrane itself is liable to occur than with organic felts, prior to repairs.

2. A glass felt BUR generally yields greater tensile strengths or, in laymen's terms, better resistances to cracking, splitting and other thermal shock effects.
3. Glass felt BUR's, properly installed, generally have much less blister potential than organic BUR's, given the greater porosity of glass felt versus organic felt. Entrapped moisture has a better chance of escaping.

*What special application techniques are involved?*

An essential application consideration when applying glass felt is a continuous film of interply asphalt at the rate of 20 to 25 lbs/100ft<sup>2</sup>. Because the glass felt is porous, it offers no inherent moisture resistance. Four (4) plies of organic felt without any asphalt would probably keep a building watertight for a period of time. Because a glass felt is porous, the same would not occur. Voids, those areas where no interply asphalt occurs, can lead to leaks in a glass BUR. The other potential problem with a glass felt is dislocation. Glass felts have a memory; in other words, they want to lie flat and straight. If a contractor steps on a glass felt and "dislocates" the felt, it will eventually want to return to its original flat and straight position, which may lead to a void. Another example would be if the felt goes off line, it may create a fishmouth.

*What is the difference between a Type IV, and a Type VI?*

The product standard for glass roofing felts in Canada is ASTM D2178. Two types of glass felt are available: D2178 Type VI and D2178 Type IV. The difference between the two is in breaking strength. A Type IV glass felt must meet 44 lbs in both machine (the direction in which the felt is made) and cross directions, while the requirement for a Type VI glass felt is 66 lbs in both directions. Virtually all glass felt in North America is manufactured from chopped strand non-woven glass mat. A "continuous strand" reinforcement is also available and is said to yield a strong glass felt with a greater porosity than chopped strand.

*Is a three-ply application sufficient with a GFM (Glass Fiber Membrane) roofing system?*

All laboratory testing, as well as installation of a multitude of roofs in the U.S., indicates that three (3) plies of GFM Type VI outperforms four plies of either No. 15 organic felt or Type IV glass felt.

*Why can't GFM Type VI be used to strip in flashing details?*

Two reasons, the first being the memory element of glass. Glass felts want to lie flat and straight, so if a high parapet is involved, and is subject to intense heat, unless the felt is well nailed, it will want to slide. The second reason is also connected to memory in the sense that a glass felt does not conform easily to bends and irregularities in flashing details.

*Okay, what do I use for flashing?*

Almost every manufacturer of glass felt is now recommending a modified bitumen flashing with its glass BUR's. Few would argue that flashing is the most vulnerable area of the roof and a modified bitumen conforms well, can be easily nailed, can be torch or mop applied, and can be prefinished with ceramic granules.

*Okay, I get my first GFM Type VI specification, what do I tell the mechanic when I get on the roof?*

1. A continuous coat of interply asphalt, no voids, is absolutely critical. The rate should be 20-25 lbs/100 ft<sup>2</sup> and minimum 400 □ EVT.
2. Tell him to avoid walking on freshly applied layers as much as all possible. Freshly applied layers can be displaced or dislodged until the asphalt is "set".
3. Brooming doesn't work because the felt is porous and the broom picks up asphalt. Sheets should be lightly squeegeed to ensure complete embedment. Tiny droplets of asphalt appearing through

the sheet are usually an indication of good embedment. The application of glass felt is called "back lining".

4. Handle rolls with care. Banging or dropping the rolls can damage the felt.
5. Rolls should be applied as straight as possible. Cut fishmouths while asphalt is hot and step them down. Avoid "ganging" more than 3 or 4 rolls if hand mopping.

### **Bitumens**

In a built-up roof, the actual waterproofing agent is the bitumen, a thermoplastic material that "welds" the three or four plies of felt into a membrane. The felts reinforce and stabilize the bitumen layer. The proper temperature is critical to the application of bitumen. The felts must also be dry and free of wrinkles and imperfections. Foreign matter (such as gravel) must not be allowed to lodge between the felts.

### **Application Temperatures**

Heating bitumen to very high temperatures for long periods of time (over four hours) reduces the asphalt softening point, and raises the coal tar softening point. Concern over these properties has resulted in the practice of using temperatures lower than the Equiviscous Temperature (EVT). The negative effects of these lower temperatures include thick moppings, poor adhesion, splitting, slips, and voids. The opposite problem, excessively high temperatures (above EVT), may lead to incomplete coverage of the film, voids, and the consequential penetration of moisture into the membrane. The following table shows the preferred range of application temperatures (EVT) for each type of asphalt and coal tar. In built-up roof installations, the mopping temperatures are critical to the performance of the roof. Therefore, an accurate kettle temperature gauge is an obvious requisite.

### **Thickness of Bitumen Coatings**

If there is good drainage, a thin coat of Type III Steep Asphalt will provide a measure of protection for the roof membrane. For this flood coat, the roofing mechanic should remember that more is not better. A thick application (over 30 pounds per 100 square feet) is subject to cracking ("alligating"). Thick coatings also tend to slump, or run down the slopes and into the gutter or over the gravel stop. Most manufacturers' specifications call for a coating of 15 to 20 pounds per 100 square feet, or just enough to solidly coat the surface of the roof. If the pitch of the roof is more than 3:12, Type IV, or Special Steep Asphalt, should be used (see Table). For these steep roofs, the use of asphalt emulsion applied at three gallons per 100 square feet, or fibrated aluminum roof coating applied at two gallons per 100 square feet offers excellent protection.



Table of Roofing Bitumen Properties			
	Softening Point		Max. Htg. Temp.
	Min.	Max.	
Asphalt ASTM D312-78			
Type I Dead Level Asphalt	135F	151F	475F
Type II Flat Asphalt	158F	176F	500F
Type III Steep Asphalt	185F	205F	525F
Type IV Special Steep	210F	225F	525F
Coal Tar Pitch ASTM 450-78			
Type I Coal Tar Pitch	126F	140F	425F
Type II Waterproofing Pitch	106F	126F	425F
Type III Coal Tar Bitumen	133F	147F	425F

Table of Roofing Bitumen Properties

### Coal Tar versus Asphalt

The major material choices for BUR surfacing are coal tar and asphalt. A larger quantity is required for coal tar pitch than asphalt for a given specification. Where 170 pounds of asphalt bitumen meet a certain specification, the same coverage would require a larger quantity of coal tar bitumen. Coal tar bitumen also costs about 50% more than asphalt, per ton. Therefore, there is a significant price difference in the use of coal tar versus asphalt, due to both the quantity required, and the cost of the bitumen. In many areas, the labour cost is also higher for coal tar than for asphalt, due to the noxious fumes it emits. For these reasons coal tar has been virtually eliminated in BUR applications.

### Surface Material

Most roofing specifications require that a surfacing material be installed after the felts are laid. The purpose of the surfacing material is to protect the felts from direct sunlight, severe weather, fire, and impacts. Roofs without surfacing develop tiny cracks in the asphalt ("alligatoring"), caused by ultraviolet rays. This network of cracks may lead to "ponding" (water collecting in surface depressions) and may eventually destroy the roofing membrane.

Surfacing materials also provide reflectivity, thereby lowering surface temperatures and insuring longer membrane life. Surfacing yields a "thicker" flood coat as the bitumen fills the voids between pieces of aggregate.

### Aggregate

Aggregate (gravel) surfacing is the method most commonly used for the protection of membranes. However, gravel surfacing should not be employed on roofs with a slope greater than 2:12. In these applications, emulsion or fibrated roof coatings are required. From the viewpoint of insurance loss prevention, gravel or slag surfacing is much preferred over smooth surfacing because of its fire protection, hail-shielding properties, and low slippage.

Aggregate used for surfacing should be opaque, about 3/8 inch average diameter, and well-embedded in the flood coat. It should meet ASTM Standard D-1863 for aggregate surfacing. Limestone is sometimes used for surfacing, but should be generally avoided as it is relatively soft and tends to dissolve with repeated freeze/thaw cycles. River bed pea gravel contains shells and mud. This type of material should be washed often and any shells removed during grading.

Some inspectors require that aggregate surfacing immediately follow the installation of the ply sheets. This requirement is valid in the case of organic felt installations, as the sheets curl if left exposed. It is advisable to install the plies well ahead of the surfacing operation so the bitumen may set. This lag time also prevents gravel from entering the space between the plies.

Aggregate is traditionally embedded in a flood coat of bitumen applied at 60lb per 100 sq. ft. and applied with a dipper or mechanical spreader. The aggregate should be "cast" (spread) into the flood coat either with shovels or mobile spreaders. Unless the spreading is done skilfully, soon after the flood coat, the bitumen can cool and harden, the aggregate insufficiently embedding in the bitumen. Erosion of the aggregate can result, leaving bare bitumen.

The logistics of the aggregate spreading operation are critical. It is important that aggregate be on hand when it is required. Most roofing contractors use material hoppers set up beside the building in order to facilitate the movement of material to the point of application on the roof.

### ***Basic Rules of Successful Built-Up Roofing***

If certain basic principles are upheld, BUR should perform well for 20 years or more. The following guidelines offer a good starting point.

#### **Rule 1: Slope the Roof**

The first rule of successful roofing is: never design a flat or "dead level" roof! The design of near-level or dead-level roofs will eventually result in ponding and deterioration of flashing and roofing materials.

#### **Rule 2: Inspection**

The second rule is to provide periodic inspection during the placement of roofing, by a knowledgeable inspector. Manufacturers' published specifications have been developed through experience in the field. Carefully following such specifications should lead to a serviceable built-up roof. Proper preparation of contract documents and carefully designed roof details also contribute to the quality of the roof installation, though they cannot ensure it. Quality control must be ensured at the point of "manufacture," on the roof. Indeed, there is no substitute for inspections by a knowledgeable person, together with a conscientious use of thorough documentation. The National Roofing Contractors Association (NRCA) advises, "periodic thorough visual inspections by a knowledgeable person during application is far preferable to test cuts as a means to monitor the roof application."

#### **Rule 3: Restore Temporary Roofs**

The third rule is to always restore temporary roofing before applying the permanent built-up system. The practice of installing the first plies and one "mopping," then allowing other trades to use it as a staging area, and finally mopping in the additional plies and ballast, has become common as time becomes a crucial factor on construction projects. If a temporary roof is required, it should be properly restored before the permanent roof is installed.

All accessories, curbs, and penetrations through the roof should also be in place before the roof is installed.

#### **Rule 4: Keep Materials Dry**

The fourth rule is to protect roofing and insulation materials from moisture before, as well as during, construction. The system is susceptible to moisture before, during, and after the roof installation. Prior to installation, roofing materials (especially insulation) must be protected from moisture infiltration. Simply covering these materials may not be sufficient. Some insulations have been found to absorb moisture while stored in a warehouse, to the extent that they are too "wet" to install. It is important to store material off the floor or ground on pallets, and cover it with tarpaulins. The lightweight plastic

wrapping that the materials are shipped in is usually not a sufficient covering because it tends to tear easily.

Wet Decks – Lightweight concrete decks are always a concern to the roofing contractor. It is important that they be properly vented. Most specifications call for the roofing contractor to "approve" the deck design before plans for proceeding with roof installation. The roof installer should perform a deck dryness test after having allowed for curing time.

The following procedure, recommended by the NRCA, provides an acceptable means of testing the dryness of the roof deck:

1. Use approximately 1 pint of bitumen that is specified for use in the roof membrane, heated to a temperature that will ensure an application temperature of 400 °F.
2. Pour the bitumen on the surface of the deck. If the bitumen foams, the deck is NOT dry enough to roof.
3. After the bitumen has cooled, an attempt should be made to strip the bitumen from the deck surface. If the bitumen strips clean from the deck, the deck is NOT dry enough to roof.

#### **Rule 5: Avoid the Void**

The fifth rule of successful roofing involves the prevention of voids between plies in a BUR. The most prominent cause of failure in BUR's according to a CA survey was interply blistering.

To prevent voids, an even bitumen application is essential; this can be obtained when the application temperature of the bitumen is in the equiviscous temperature range (EVT). The EVT is usually printed on the asphalt container. The roofing contractor must heat the bitumen in the kettle to a temperature above the EVT, but below the flash point, in order to allow for the chilling of the asphalt as it is transported and applied. Traffic or other factors that could cause movement to the fresh application must be avoided.

#### **Summary**

Despite the popularity of single-ply roofing systems, built-up roofing continues to be a mainstay in contemporary construction. BUR offers the specific advantages of additional layers of protection from moisture penetration, and an ability to seal itself in warm weather. Since it has such a long history, it has a proven "track record". Over the years, roofing installers have become familiar with this system and BUR manufacturers have had the opportunity to improve upon its basic materials.

---

## **SECTION 4.g MODIFIED BITUMINOUS MEMBRANES (TORCH ON)**

Bituminous and modified bituminous membranes represent a large share of the flexible membranes that have replaced traditional built-up roofing felts. While offering the higher performance and versatility of a flexible membrane, these products also offer the practical advantages of bituminous materials (i.e. they are generally compatible with asphalt products and may be useful for re-roofing projects).

### **COMPOSITION**

Bituminous and modified bituminous flexible membrane systems are composite sheet membranes which are thermoplastic in nature but display variable elastomeric properties when modified. These sheets generally consist of bitumen (oxidized or modified), reinforcement, and surfacing materials. The performance of these membranes may be compromised by subtle, seemingly inconsequential changes in composition.

The formulation of the bitumen is critical, particularly when its physical properties are modified by the addition of polymers. Bitumen is most commonly modified with styrene butadiene styrene (SBS) or

atactic polypropylene (APP). The manufacturer must ensure that a suitable degree of compatibility exists between the bitumen and the polymer and that a thorough mix has been obtained. The careful selection and combination of bitumen and polymer (the type of modifier, the percentage of polymer used, etc.) determines the physical properties and long term performance of the modified bituminous "binder". The binder provides the membrane with its waterproofing capability and may impart the following properties:

- low temperature flexibility
- elasticity
- high temperature resistance to flow
- resistance to aging
- The bitumen utilized for oxidized bituminous membranes has been "blown", similar to roofing asphalt. This produces a higher softening point and, therefore, a more useful temperature range.
- The physical properties of the binder are further enhanced by the imposition by saturation or coating onto a carrier or reinforcing mat, most commonly a textile such as:
  - non-woven spun-bonded polyester
  - woven polyester scrim
  - fibreglass mats
  - woven fibreglass cloth
  - combination of the above.

(Some polyester modified membrane manufacturers use oxidized bitumen to saturate the reinforcing, particularly when "heavyweight" reinforcing is used). The type of reinforcing selected depends on the end use and desired physical properties of the finished products. The weight, quality, tension during manufacturer, and method of saturation and coating of the reinforcing, are some of the factors governing the final product's performance.

Membranes are usually surface treated with a parting agent so they do not stick in the roll. Surfaces that will be hot asphalt applied are usually sanded while torch-applied surfaces use polyethylene or other thermofusible films. Exposed surfaces may be embedded with mineral granules (usually ceramic chips or slate flakes) or laminated with metal foil for ultra-violet protection. As an alternative on roofs with minimal slopes, a pour coat and gravel surfacing may be installed over some membranes, although this makes the quality of application difficult to inspect and may lead to problems with membrane slippage due to the weight of the cap sheet and surfacing.

The thickness of the membrane should be suited to the method of application. Torchable membranes must be thick enough to allow the underside to be melted without burning through to the reinforcing and thin enough to be manageable in winter conditions. Hot asphalt applied (mopped) membranes should be of sufficient thickness to perform adequately but should not act as a "heat sink", lowering the temperature of the asphalt before a sufficient bond is achieved. Manufacturers often refer to membrane thickness in one of two ways. "Nominal Thickness" usually refers to the thickness including any granular finishes. As the granular surfaces do not contribute to the performance of the membrane (except as ultra violet protection and appearance), thickness measured "at the selvage edge" usually gives a more accurate indication of the physical properties of the membrane related to thickness.

## **PERFORMANCE**

The physical properties of the membranes available today vary greatly. Each membrane manufacturer "tackles" the problems of roofing technology differently, based on individual design criteria. The design authority, in consultation with the manufacturers, must identify the properties most important for the performance of the roof system on an individual project basis.

As a precaution, RGC has accepted the following performance limitations, based on the lowest expected in-service temperatures of the membrane:

Temperatures warmer than -10°C (+14°F) require membranes with a minimum tensile strength of 150 N/50 mm.

Temperatures warmer than -18°C (0°F) up to -10°C (+14°F) require a base sheet or cap sheet with a minimum tensile strength of 294 N/50 mm (CGSB 37-GP-56M Grade 1).

Temperatures colder than -18°C (0°F) require a base sheet or cap sheet with a minimum tensile strength of 785 N/50 mm (CGSB 37-GP-56M Grade 2).

The design of a roof membrane system is contingent upon many factors and is not solely a function of design temperatures. Consult the membrane manufacturer for assistance with design considerations and membrane selection.

## **APPLICATION**

As with all flexible membranes, the quality of the installation is critical to the performance of bituminous and modified bituminous membranes. Although some of the application techniques for these membranes can be similar to those employed in built-up roofing, and the materials can be "familiar", the differences are critical. It is important that the specifications, details, and installation techniques all conform to the membrane manufacturer's requirements.

One of the major concerns when applying these membranes with hot asphalt is to ensure the asphalt remains hot enough to fuse with the binder of the membrane. The asphalt temperature must conform to the membrane manufacturer's minimum application temperature and minimum +205°C (+400°F) as required by RGC Guarantee Standards. Asphalt should not be mopped more than 1 m (3') preceding the roll as it has been demonstrated that the temperature of mopped asphalt drops sharply once mopped out.

In addition to asphalt temperature, particular attention should be paid to slope limitations, fastening requirements, type of asphalt, the amount of asphalt used, and membrane flashing requirements when using hot asphalt. Some manufacturers may require "torched" membrane flashings to ensure a proper bond and prevent problems with slippage or asphalt running down the vertical and collecting at the cant. Slippage can also be a problem when an excessive amount of asphalt is used. Only enough asphalt to meet the adhesive requirements is needed. The mopping asphalt has a lower softening point than the bitumen in the membrane and may result in asphalt running and slippage problems.

The major concern when installing "torch-on" membranes is an obvious one: SAFETY. In addition to safety, it is essential that the membrane be fully and evenly bonded to the substrate. As the roll is installed, the roofer must ensure the full width of the roll is melted and the preceding roll's side lap is preheated. A small "wave" or "bead" of melted bitumen in front of the roll usually indicates sufficient heat. Special attention to seams is required.

The polyester fabric used as reinforcing in many thermofusible ("torch on") membranes is subject to dimensional changes at high temperatures. Care must be exercised by the applicator not to over-torch or over-heat membranes. Membranes must be designed and manufactured specifically for torch applications.

It is recommended that the cap sheet installation immediately follow base sheet installation in all cases. However, when it may be necessary to delay the installation of the cap sheet due to weather, project scheduling or the like, then the following criteria must be considered:

ANY delay in the installation of a cap sheet will result in the requirement for a special inspection and thorough cleaning of the base sheet. The inspection is for mechanical damage from traffic or trades and cleaning is necessary to ensure good adhesion; this must be done to the satisfaction of the roofing contractor.

Sanded base sheets should have a thin squeegee glaze coat of asphalt applied immediately after application of base sheet if any delay for cap installation is anticipated.

Base sheets which are either sanded, glaze coated or thermofusible can be exposed for up to six months. It must be recognized that an exposed base sheet is vulnerable to mechanical damage and construction dirt. The base sheet should be well protected by carefully placed and maintained protection panels (plywood for example). This protection would be supplied, installed and removed by someone other than the roofing contractor.

Consult manufacturer(s) for specific construction details and specifications.

#### **APPLICATION CAUTION:**

#### **MODIFIED BITUMEN MEMBRANES IN HOT MOPPED ASPHALT**

The design authority should recognize that the appearance of wrinkling and ridging in modified bitumen cap sheets applied in hot asphalt may be generic to certain manufacturers of this system, and particularly when attempted in cooler temperatures. Although some manufacturers' literature suggests application may take place in temperatures as low as -25°C (-13°F), there are many subsequent limitations, the variables of which may result occasionally in severe wrinkling or ridging of the cap sheet as well as potentially poor adhesion.

RGC recommends that, in order to minimize the potential for wrinkling and ridging, the use of mopped cap sheets not be considered or specified when ambient temperatures (including wind chill) may go below +5°C (+41°F).

Many factors affect the behaviour of the finished prefabricated sheets including:

- The quality of the binder (waterproofing agent).
- The choice of carrier including suppliers of fibreglass, polyester, or a combination of the two.
- Saturation of the carrier.
- Engineering of the sheet (composition and placement of the components within the sheet).
- Quality control of the manufacturer.
- Expertise of the manufacturer's personnel (including field representation).
- Recommendations as to what is required for a completed system and the recommended application procedure.
- Installation in the field by a competent contractor.
- The designer's role in choosing the product(s) which satisfy each previous item described.
- The wrinkles or ridges are usually considered an aesthetic problem only, but may occasionally result in fishmouthing and intermittent bonding of the cap sheet. Both of these deficiencies affect the performance of the membrane.

RGC recommends the use of torch applied thermofusible cap sheets in 2-ply modified bitumen systems in all cases, but particularly if roofing must be carried out in cool or cold weather. Appropriate safety precautions regarding torching must be addressed.

Occasionally some mopped systems, particularly with heavy cap sheets, have exhibited a propensity for membrane slippage, frequently on insulated systems where there is a combination of slope, heavy inter-ply mopping and lack of mechanical fastening (back nailing) of sheets.

It is also common for mopped systems to exhibit some asphalt bleed-out at the seams. Minimal or reasonable bleed-out is to be expected and is an aesthetic problem which may be minimized by the embedment of matching granules. Bleed-out which oxidizes and alligators with time does not normally affect the waterproofing efficiency of the roof.

### ***SBS (STYRENE BUTADIENE STYRENE)***

Styrene butadiene styrene (SBS) polymer modifiers are "thermoplastic elastomers". They are elastomers, which behave similar to both thermoplastics and thermosets (or "elastomerics"). Thermoplastics soften with heat and harden when cooled, no cross-linking (vulcanization) of molecules occurs, and they tend to exhibit "plastic" properties. Thermosets are materials in which cross-linking of the molecules occurs and they tend to exhibit "elastomeric" or rubber-like properties.

Simply stated, flexible polybutadiene "chains" interconnect with the glass-like polystyrene "blocks" and, when cooled, the resulting network behaves as if the molecules were cross-linked. The process is repetitive in that the networks may be disrupted by heat or solvents but will reform upon cooling or removal of the solvents.

Bitumens modified with SBS can display improved physical and mechanical properties. The improved properties are only possible if the SBS polymer is properly dispersed within a suitable bitumen. A well dispersed, homogeneous polymer mixture will form a continuous rubber network throughout the bitumen.

SBS modification of bitumens can impart the following changes in properties:

- increased softening point
- improved low temperature flexibility
- greater elasticity
- improved aging characteristics

### ***APP (ATACTIC POLYPROPYLENE)***

Atactic polypropylene (APP) polymer modifiers are by-products of the polymerization of propylene gas into isotactic polypropylene (used for injection molding and extrusion). APP has a lower melting point and is more compatible with asphalt than isotactic polypropylene.

Bitumens modified with APP can display improved physical and mechanical properties. The improved properties are only possible if the APP is finely dispersed throughout the bitumen to avoid separation during manufacture and service.

- APP modification of bitumens can impart the following changes in properties:
- increased softening point
- improved ultraviolet radiation resistance
- improved low temperature flexibility

Cold Weather Application:

Designers and contractors should recognize that APP modified bitumen membranes can be extremely difficult to work with in colder temperatures, and that even attempting to unroll the material in very cold temperatures may result in cracking of the sheet or other problems.

Some manufacturers make different grades of material for application at different times of the year. Most manufacturers recommend an application temperature lower limit of approximately 5°C (40°F). **DO NOT ATTEMPT** to install APP modified bitumen membranes below these recommended temperatures.

---

## **SECTION 4.h MEMBRANE ROOFING NON-BITUMINOUS**

### ***GENERAL***

Due to the complexities involved in non-bituminous flexible membranes, "generic" application specifications and details are not possible. This section of the manual contains both an overview of the products, their composition, usage, and design considerations, and the accepted membrane manufacturer's written submissions. In all cases, the membrane manufacturer should be contacted for further recommendations and details.

In order to formulate materials to satisfy the requirements of a roof membrane, the manufacturer must ensure:

- Strict Quality Control
- Proper Mix of Ingredients
- Consistency of Batches
- Minimum Physical Properties are Obtained

The chemical formulations of specific flexible membranes can be complex, but the end product can generally be defined as either a THERMOSET or THERMOPLASTIC

### ***THERMOSET MATERIALS (ELASTOMERIC)***

Thermoset is defined as a material that solidifies or "sets" irreversibly when heated (vulcanized). This property is usually associated with cross-linking of the molecules induced by heat or radiation. Once the material is cured, it can only be bonded to itself by adhesives; new molecular linkages cannot form. Some thermosets are not cured during manufacture (i.e. EPDM flashings) and are intended to cure over time after they have been installed. This allows the material to cure into the specific shape required for the roofing application.

The generic membrane types defined as cured thermosets include:

EPDM (Ethylene Propylene Diene Monomers)

Neoprene (Chloroprene Rubber)

CPE\* (Chlorinated Polyethylene)

Uncured thermoset membranes include:

CSPE (Chlorosulphonated Polyethylene)

CPE\* (Chlorinated Polyethylene)

PIB (Polyisobutylene)

NBP (Nitrile Alloy)



\*CPE's may be formulated to be used as either a cured or uncured membrane.

#### EPDM (ETHYLENE PROPYLENE DIENE MONOMER)

EPDM is a thermoset, synthetic rubber membrane formulated from ethylene, propylene, and a small amount of diene monomer. Although most commonly available as a cured sheet, EPDM can be formulated as an uncured membrane for specific purposes (i.e., flashings).

EPDM roof systems are single-ply membranes available in thicknesses ranging from a nominal 1.1 mm (.045") to 1.5 mm (.060") and are usually black or white in colour. The membrane may be applied loose-laid and ballasted, mechanically-fastened, or fully-adhered. Seams are joined with contact splicing cement or seaming tape (or a combination of both), and are sometimes caulked (see manufacturer's requirements).

EPDM membranes should conform to CGSB 37-GP-52M 1984, "Roofing and Waterproofing Membrane, Sheet Applied, Elastomeric" which lists two types of membrane, according to manufacture:

Type 1 – non-reinforced

Type 2 – reinforced

and two classes, according to end use:

Class A – exposed

Class B – non-exposed

This standard covers requirements such as "thickness, tensile strength, breaking strength, lap joint strength, elongation, tensile set, low temperature flexibility, water absorption, dimensional stability after water absorption, heat aging, ozone resistance, resistance to accelerated weathering, dynamic impact test, tear resistance, and tearing strength."

#### **THERMOPLASTIC MATERIALS (PLASTOMERIC)**

Thermoplastic materials are defined as polymers which soften when heated and harden when cooled. This process is repetitive provided the material is not heated above the point at which decomposition occurs. No cross-linking or vulcanization occurs. In addition to heat welding, some materials can be solvent welded. These welds develop bonding strengths equaling or surpassing the strength of the base materials.

Thermoplastics materials used for roof membranes include:

PVC (Polyvinyl Chloride)

EIP (Ethylene Interpolymers)

ECB (Ethylene Copolymer Bitumen)

TPO (Thermoplastic Polyolefins)

EPR (Ethylene Propylene Rubber)

#### **PVC (POLYVINYL CHLORIDE)**

PVC is a thermoplastic material produced through the polymerization of vinyl chloride, resulting in a relatively hard, resinous material. This material is then formulated with compounds, such as plasticizers and stabilizers, depending on the physical properties required for end use. PVC formulations have been developed to suit numerous commercial and industrial applications.

PVC roof systems are single-ply membranes available either non-reinforced or reinforced with polyester fabric or glass fibres, and in thicknesses usually ranging from 1.2 mm to 2.0 mm, depending on the

manufacturer. Non-reinforced PVC membranes may typically exhibit excessive shrinkage characteristics, thus their use is often discouraged. The membrane may be applied loose-laid and ballasted, mechanically fastened, or fully adhered. Seams are heat or chemically welded (see manufacturer's requirements).

PVC membrane should conform to CGSB 37-GP-54M 1979, "Roofing and Waterproofing Membrane, Sheet Applied, Flexible, Polyvinyl Chloride" which lists two types of membrane, according to manufacture:

Type 1 – non-reinforced

Type 2 – reinforced

and four classes, according to end use:

Class A – non-exposed roofing

Class B – exposed roofing

Class C – waterproofing

Class D – flashing membrane asphalt compatible

This standard covers requirements such as "thickness, lap joint strength, permeability, tensile strength, elongation at break, low temperature flexibility, water absorption, resistance to accelerated weathering, dimensional change after stress relaxation, and cone penetration"

PVC membranes should be applied in conformance with CGSB 37-GP-55M 1979, "Application of Sheet Applied Flexible Polyvinyl Chloride Roof Membrane" and the membrane manufacturer's printed instructions.

### ***TPO (THERMOPLASTIC POLYOLEFIN)***

TPO single-ply membranes are made of flexible polyolefin polymers. TPO polymers are formed by chemically linking up olefin molecules that soften when heated. This characteristic permits TPO membranes to be heat-welded for seaming of sheets and membrane flashings.

The polymers used to form TPO membranes vary between manufacturers, polypropylene, polyethylene and isobutylene, as well as their derivatives are used in the various manufacturing processes. TPO's do not contain plasticizers.

TPO single-ply membranes are reinforced with polyester, fiberglass or a combination of both fabrics. Membrane reinforcement provides dimensional stability as well as strength to resist in service stresses. Membrane thicknesses range from 1.14mm (45 mils) to 1.52mm (60 mils), and approvals from Factory Mutual (FM), UL and ULC may be available depending on the manufacturer.

TPO membranes must be applied in conformance with the membrane manufacturer's printed instructions.

### **NON-BITUMINOUS FLEXIBLE MEMBRANE CONSTRUCTION DETAILS**

The drawings contained within this section are intended to represent a variety of non-bituminous flexible membrane roof system designs while remaining generic with regards to manufacturers' specific application specifications. They do not represent all possible manufacturer application roof system designs.

**SINGLE PLY MEMBRANE:  
MECHANICALLY ATTACHED GENERIC CONVENTIONAL ASSEMBLY**

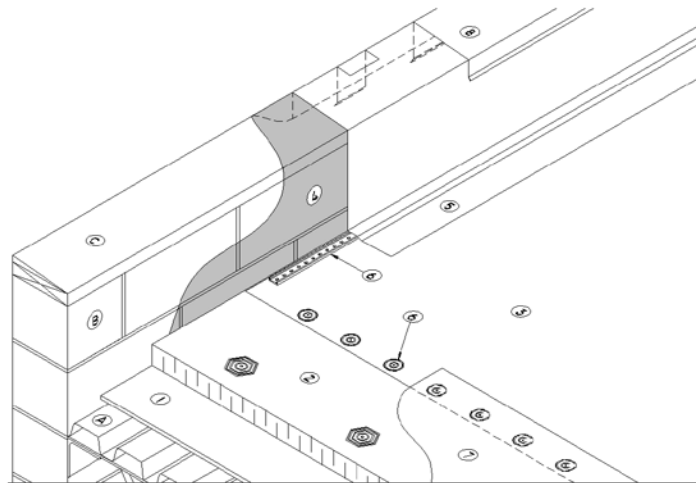

**WORK INCLUDED**

1. Gypsum Overlay Board: May be required depending on insulation thickness or when required as a thermal barrier by design authority.
2. Insulation: Mechanically attached. Installed according to Guarantee Standard A4.3.
3. Single Ply Membrane: Installed according to manufacturer's printed instructions.
4. Adhesive: Proprietary, installed according to manufacturer's instructions, usually brushed, rolled or sprayed.
5. Membrane Flashing: Adhered according to manufacturer's printed specifications using proprietary adhesive. Must be carried to outside of parapet or minimum 200 mm (8") above finished roof surface.
6. Fasteners: Install according to manufacturer's instructions (style may vary depending on material type and manufacturer's specification).
7. Membrane Lap: Thermoplastic membrane may be welded or chemically bonded. Thermoset membrane may be joined using uncured tape or proprietary adhesive.
8. Metal Flashing: As required by RGC standards.

**RELATED WORK BY OTHERS**

- A. Acceptable Deck
- B. Acceptable Parapet Surface: Surface must be smooth, dry and clean. Rough surface must be covered with treated plywood, to be determined by design authority or inspector or as required by manufacturer.
- C. Sloped Wood Blocking

## SINGLE PLY MEMBRANE: FULLY ADHERED

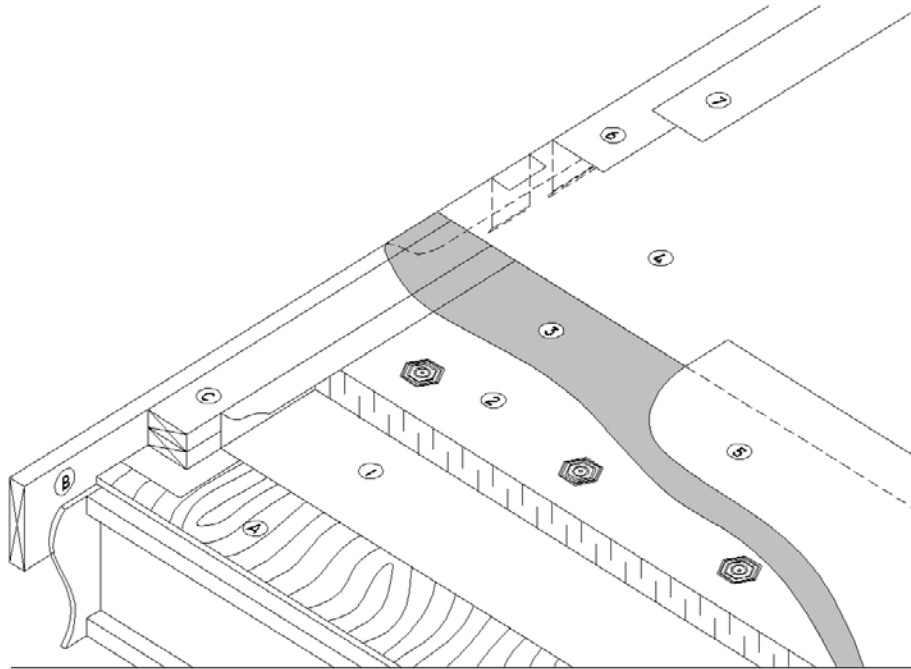

## WORK INCLUDED

1. Vapour Retardant: If required by design authority.
2. Insulation: Mechanically attached where deck type permits.
3. Adhesive: Proprietary, installed according to manufacturer's instructions, usually brushed, rolled or sprayed.
4. Single Ply Membrane: Installed according to manufacturer's instructions.
5. Membrane Lap: Thermoplastic membrane may be welded or chemically bonded. Thermoset membrane may be joined using uncured tape or proprietary adhesive.
6. Edge Flashing: Proprietary.
7. Membrane Flashing: Installed according to manufacturer's instructions.

## RELATED WORK BY OTHERS

- A. Acceptable Deck
- B. Fascia: Optional
- C. Wood Blocking: Equal to height of insulation.

## SINGLE PLY MEMBRANE:BALLASTED PROTECTED MEMBRANE

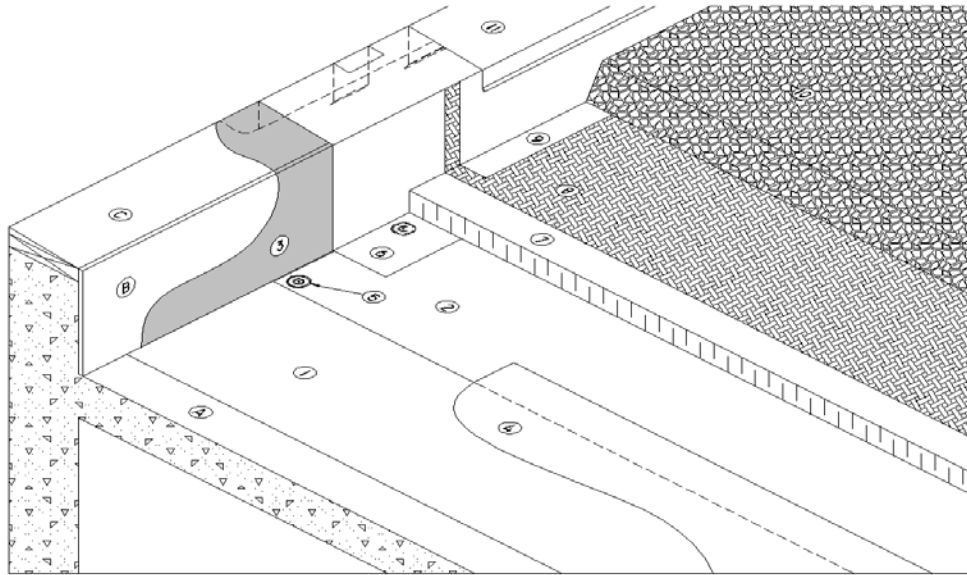

## WORK INCLUDED

1. Protection Mat: Provide protection between concrete deck and membrane with installation of manufacturer specified and RGC accepted protection mat or deck overlay boards.
2. Single Ply Membrane: Installed according to manufacturer's instructions.
3. Adhesive: Proprietary, installed according to manufacturer's instructions, usually brushed, rolled or sprayed.
4. Membrane Lap: Thermoplastic membrane may be welded or chemically bonded. Thermoset membrane may be joined using uncured tape or proprietary adhesive.
5. Fasteners: Install according to manufacturer's instructions (may vary from drawing).
6. Membrane Flashing: Adhered according to manufacturer's printed specifications using proprietary adhesive. Must be carried to outside of parapet or minimum 200 mm (8") above finished roof surface. Welded or adhered to primary membrane depending on membrane type.
7. Insulation: Installed according to Guarantee Standard A4.3
8. Filter Fabric: Metal base flashing required.
9. Metal Flashing: As required by RGC standards.
10. Ballast: Gravel or concrete paving tiles.
11. Parapet Flashing: As required by RGC standards

## RELATED WORK BY OTHERS

- A. Acceptable Deck
- B. Acceptable Parapet Surface: Surface must be smooth, dry and clean. Rough surface must be covered with treated plywood, to be determined by design authority or inspector or as required by manufacturer.
- C. Sloped Wood Blocking

## SINGLE PLY MEMBRANE: CURB OPENING

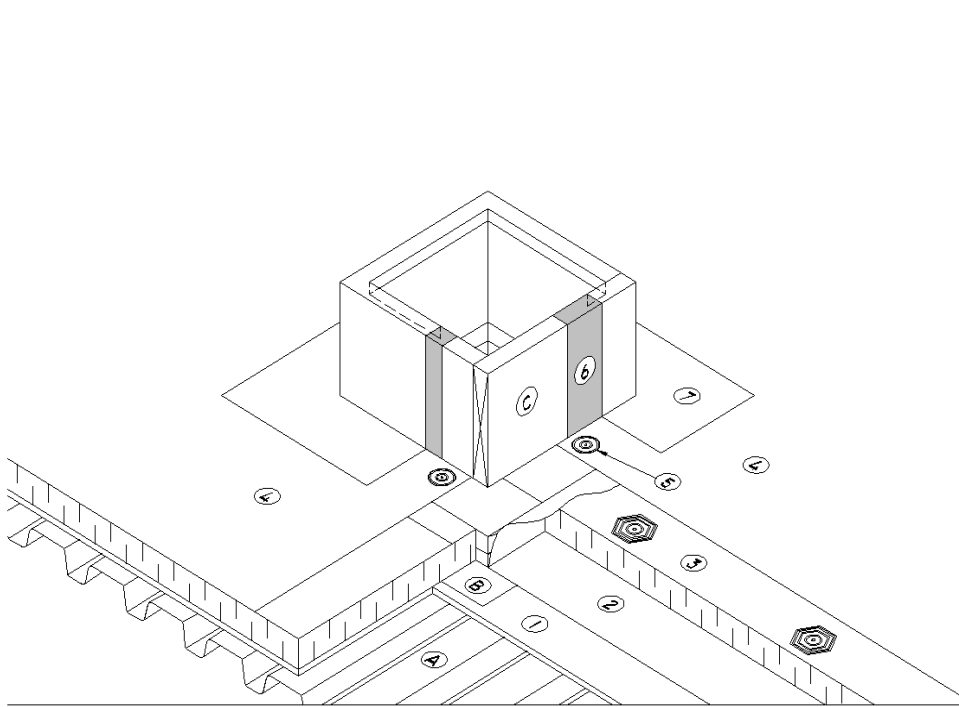

## WORK INCLUDED

1. Gypsum Board: Required when insulation is too thin to span flutes of steel decking or when required as thermal barrier by design authority.
2. Vapor Retarder: If required by design authority.
3. Insulation: Mechanically attached or loose laid for ballasted roof assemblies.
4. Single Ply Membrane: Installed according to manufacturer's instructions.
5. Fasteners: Install according to manufacturer's instructions (may vary from drawing)
6. Adhesive: Proprietary, installed according to manufacturer's instructions, usually brushed, rolled or sprayed.
7. Membrane Flashing: Adhered to curb according to manufacturer's printed specifications using proprietary adhesive. Must be carried to outside of parapet or minimum 200 mm (8") above finished roof surface. Thermoplastic membrane may be welded or chemically bonded. Thermoset membrane may be joined using uncured tape or proprietary adhesive.

## RELATED WORK BY OTHERS

- A. Acceptable Deck
- B. Vapor Retarder
- C. Blocking: Minimum 200 mm (8") in height.

## SINGLE PLY MEMBRANE: CLAMPING COPPER DRAIN

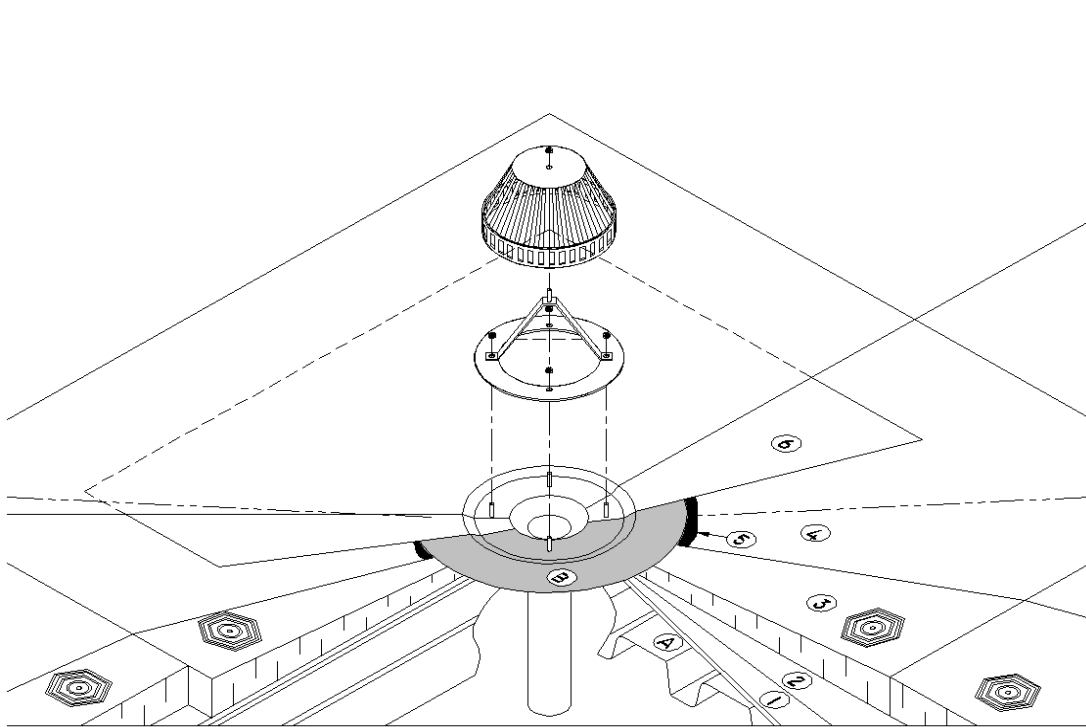

## WORK INCLUDED

1. Gypsum Board: Required when insulation is too thin to span flutes of steel decking or when required as thermal barrier by design authority.
2. Vapor Retarder: If required by design authority.
3. Insulation: Mechanically attached where deck type permits or loose laid for ballasted roof assemblies.
4. Single Ply Membrane: Installed according to manufacturer's instructions.
5. Mastic: Compatible mastic or sealant.
6. Membrane Flashing: Adhered according to manufacturer's printed specifications using proprietary adhesive. Thermoplastic membrane may be welded or chemically bonded. Thermoset membrane may be joined using uncured tape or proprietary adhesive.

## RELATED WORK BY OTHERS

- A. Acceptable Deck
- B. Clamping Copper Drain: Mechanically fastened and coated with adhesive as required by manufacturer. Installed over compatible sealant.

*Note:* Leader size is determined by design authority using the calculation found in the BC Building Code at Appendix P.7.4.10 and Table 7.4.10.11 (Table 7.4.10.10 for gutters) in conjunction with the 15 minute rainfall value from the National Building Code, Appendix C.

**SINGLE PLY MEMBRANE:  
TWO PART BOX FLASHING FOR USE WHEN DISCONNECT  
OF CABLES OR PIPES IS IMPRACTICAL**

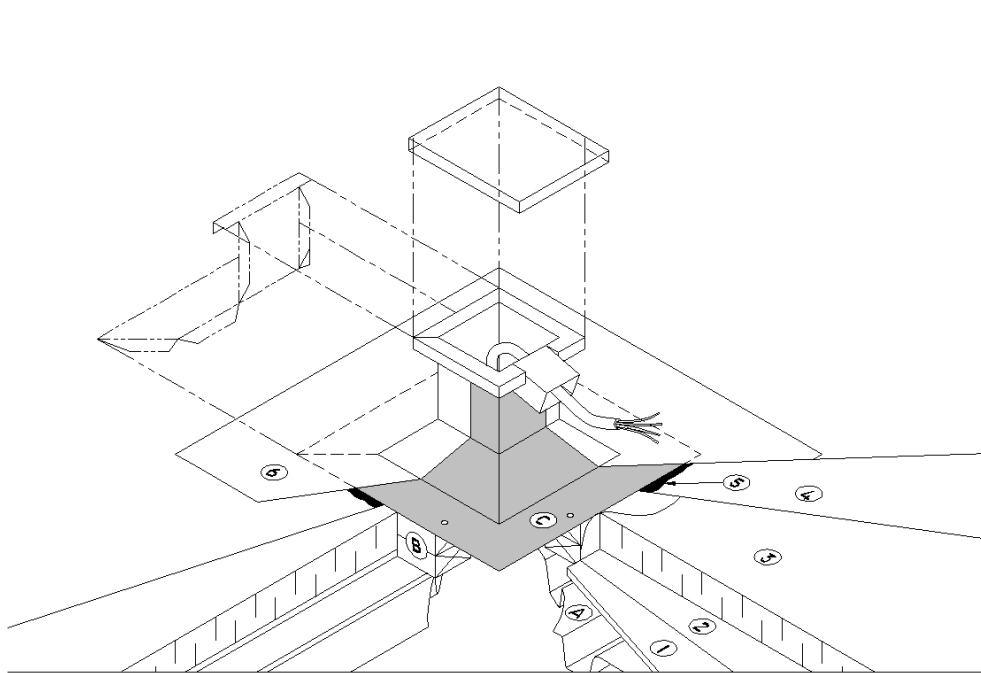

**WORK INCLUDED**

1. Gypsum Board: Required when insulation is too thin to span flutes of steel decking or when required as thermal barrier by design authority.
2. Vapor Retarder: If required by design authority.
3. Insulation: Mechanically attached where deck type permits or loose laid for ballasted roof assemblies.
4. Single Ply Membrane: Installed according to manufacturer's instructions.
5. Mastic: Compatible mastic or sealant.
6. Membrane Flashing: Adhered to curb according to manufacturer's printed specifications using proprietary adhesive. Thermoplastic membrane may be welded or chemically bonded. Thermoset membrane may be joined using uncured tape or proprietary adhesive.

**RELATED WORK BY OTHERS**

- A. Acceptable Deck
- B. Wood Blocking
- C. Two Piece Flashing: Assembled around protrusion, laid over compatible sealant on top of primary membrane. Mechanically fasten two components together and fasten flange to wood blocking or deck.



## SINGLE PLY MEMBRANE: MECHANICAL CURB OPENING

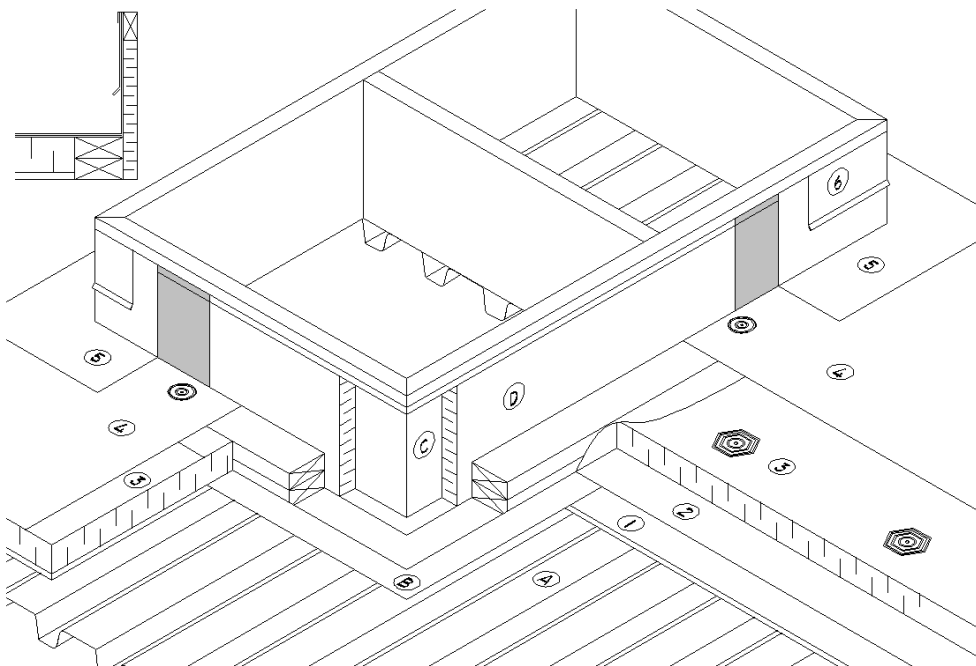

## WORK INCLUDED

1. Gypsum Board: Required when insulation is too thin to span flutes of steel decking or when required as thermal barrier by design authority.
2. Vapor Retarder: If required by design authority.
3. Insulation: Mechanically attached where deck type permits or loose laid for ballasted roof assemblies.
4. Single Ply Membrane: Installed according to manufacturer's instructions.
5. Membrane Flashing: Adhered according to manufacturer's printed specifications using proprietary adhesive. Thermoplastic membrane may be welded or chemically bonded. Thermoset membrane may be joined using uncured tape or proprietary adhesive.
6. Metal Base Flashing: Mechanically fasten, standing seam at corners. Full width base flashing optional on flexible membranes. Partial skirt flashing minimum 75 mm (3") required on mechanical curbs that require flashing under metal flange.

## RELATED WORK BY OTHERS

- A. Acceptable Deck
- B. Air/Vapour Seal
- C. Mechanical Curb: Minimum 200 mm (8") and maximum 300 mm (12") above finished roof surface.
- D. Rigid Insulation

## SECTION 5

# ROOF MAINTENANCE

The information provided in this publication from the Roofing Contractors Association of British Columbia (RCABC) was compiled as a guide to assist consumers with roofing maintenance.

This roofing guide includes information sections reprinted from the RCABC Guarantee Corp. (RGC) Roofing Practices Manual (RPM) and other publications including those used by the RCABC Educational Foundation (REF) during the training of roofing apprentices and journey persons for the province of British Columbia.

---

### SECTION 5.a THE IMPORTANCE OF ROOF MAINTENANCE

Recognizing the importance of a good roof maintenance program and to ensure that owners have the information needed to protect their building investment the Roofing Contractors Association of British Columbia (RCABC) published the Roof Maintenance Guide. The Guide provides good maintenance practices that should be followed by the building owner's or their maintenance personnel.

The most important reason for establishing a program of regular roof maintenance is to protect your building investment. A properly executed maintenance program will add years to the life of the roof by detecting minor problems before they become major, as well as providing better protection for, and avoiding interruption of, the internal functions of the building.

A roof system is exposed to all manners of chemical and physical stress. The long-term effects of these forces are called "Normal Aging". In reality, small isolated problems caused through abuse, stress concentration, inadequate ventilation, error, or other factors result in a shortened lifespan of the roofing system.

Small problems or defects, if not detected and repaired, inevitably become major problems affecting the performance of the whole roof system.

Roofs represent approximately five to seven percent of capital building costs – but roofs cover 100% of the building and its contents.

#### ***BASIC PREVENTIVE MAINTENANCE***

##### ***MAINTENANCE PROGRAM***

A preventive maintenance program is simply a program of scheduled inspections and subsequent corrective action. The purpose is to maximize the life expectancy of the roofing system, thus providing maximum protection to building and contents and minimizing overall costs.

The basic elements of a preventive maintenance program for roofs are:

- Regular visual inspections to determine the current condition of the roof membrane and flashings.
- Immediate repair of any defect before it allows moisture to enter the roof system or building interior.
- Non-destructive moisture detection to determine if moisture has infiltrated into the insulation of the roof system.

Note: RCABC Maintenance Guides available at [www.rcabc.org](http://www.rcabc.org) – Roofing Practices Manual.

A vital part of the condition of the roof system is whether or not the insulation remains dry. A roof may appear to be in excellent condition from the surface, but may have areas of saturated insulation, which severely affect the thermal efficiency of the roof.

Non-destructive moisture detection of roof systems has developed into a sophisticated technique that can provide accurate analysis of roof insulation condition. Two commonly used systems are nuclear meter and infrared thermography. Both systems require trained skilled operators, specific weather conditions, specific roof types, and professional analysis. Visual inspection by a trained person is the key to a successful maintenance program.

### ***INSPECTION***

Roofs should be inspected at least twice a year — Spring and Fall — and also after any significant weather or construction event.

The inspection should be preceded by the preparation of a detailed roof plan on which all defects or notes can be marked. If the inspection indicates that more than minor work is required, an inspection checklist is necessary to ensure thoroughness. Call your professional roofing contractor to perform the required maintenance work.

A typical roof plan and an inspection checklist are included in this guide for your convenience.

Begin the inspection by looking at the underside of the deck, if accessible, and also at the outside of the building. Look for cracks, stains, rusting, watermarks, efflorescence, wet spots, spalled mortar etc. or other signs of excessive moisture or deterioration. The observations may give clues to not only roofing problems but also other conditions affecting the performance of the building envelope.

The final and most important part is inspecting the roof itself. The keys to a competent roof inspection are thoroughness and attention to detail — be prepared to get dirty!

### ***DOS AND DON'T'S OF ROOF MAINTENANCE***

#### **DO'S:**

Do be aware that wise maintenance will prolong the life of any roof — even the best of them.

Do perform inspections at least twice a year, preferably at the end of Winter and right after Summer, when roofs have passed through the periods of severest stress.

Do conduct additional inspections immediately after unusual occurrences such as extremely heavy rains, high winds, hail, nearby fires, explosions, etc.

Do check the building exterior for settlement or movement. Cracks in the wall are a warning of possible cracks in the roofing and flashing. Are overhangs, cornices, fascias and edging in good condition? Are gutters and downspouts satisfactory? Breaks in roof edge elements can cause leaks and also let wind get under the roofing membrane and cause blow-offs. Damaged or clogged gutters, roof drains, and downspouts can cause water back up on the roof.

Do be certain that equipment servicemen going on the roof are warned against penetrating or dropping tools on the roof. They should be accompanied by your trained maintenance man to ensure no damage to the roof assembly occurs.

Do assure that your roof is kept clean and free from debris.

Do recognize that exposure of roof felts (bare spots) on a gravel surfaced roof can lead to quick deterioration. This requires immediate attention by qualified personnel.

Do be advised that flashings, gum pans, gravel stops and all other roof penetrations are the source of most leaks. Pay extreme and careful attention to these items.

**DON'TS:**

Don't allow unqualified personnel to maintain your roofs.

Don't allow traffic on your roof unless accompanied by your informed maintenance man.

Don't allow equipment servicemen to penetrate your roof without being certain that qualified personnel flash the penetrations. If your roof is covered by an RGC guarantee, RGC or the membrane manufacturer should be notified prior to cutting the roof or altering it in any manner.

**WHEN IT'S TIME TO REROOF****DON'TS:**

Don't permit products of unproven quality to be used on your roof.

Don't be taken in by "Cure-All" products, which can be applied by anyone.

Don't take bids on projects without adequate, uniform specifications.

Don't reroof over an existing roof unless a careful evaluation is made, and a qualified consultant or standards authority gives prior approval.

Don't expect a guarantee to keep the water out of your buildings. Guarantees do not cover many of the problem areas of your roof.

Don't think that the lowest price is always the best. Be certain you will not be faced with a number of change order requests for extras after a project is awarded.

Don't deal with firms who cannot stand behind their work and will not be available when you need them. Remember that no product is better than the applicator.

**DO'S:**

Do hire a professional roofer.

Do call a member of RCABC.

Do request the RGC Guarantee

Do benefit from:

- Independent inspections
- RGC accepted materials
- RGC Guarantee Standards

---

**SECTION 5.b CEDAR RESTORATION*****THE BREAK DOWN***

In recent years it seems an entire industry has developed around restoring cedar roofing. BC has several distinct climatic zones. Each zone has unique properties, which affect each type of roofing differently. The Northern and Central Interior areas deal with temperature extremes, cold and hot. The Southern Interior/Okanagan regions have extensive sun and extreme heat. Cedar roofing performs very well in these environments and has historically lasted upwards to 40 or 50 years. The Coast, Lower Mainland and Vancouver Island regions are temperate rainforest. Due to abundant rainfall, the

lifespan of neglected cedar roofing is reduced. Organic debris from overhanging trees, wind-blown leaves, dust and dirt combine with the spring rains to provide an excellent medium to promote the growth of moss, algae and a host of other organisms that break down a cedar roof.

This situation has spawned an army of entrepreneurs offering to extend the life of cedar roofs with high-pressure washing, and treatments with solutions of unknown ingredients while promising unrealistic warranties. Unfortunately the industry is largely unregulated, in the case of both the products and the work force. Desperate homeowners see this as a way to avoid re-roofing for another 10 years, when in fact, the damage in many cases has already been done from years of neglect.

Without question, maintenance in the form of cleaning is essential for roofing of all types but especially for cedar, since it is a natural product. High-pressure washing (with gas-powered pressure washers) can do more damage than good by removing the pulp of the cedar itself.

### **WHAT CAN BE DONE?**

Damaged and prematurely deteriorated tiles should be replaced. Ridge caps often separate due to failure of the fastener, which joins the 2 sides together causing them to open up. See illustration to right.

Ridge and hip caps oppose the flow of water along the grain so they tend to break down a little sooner than field tiles. They should be repaired or replaced as required. Even cracked or warped field tiles can be replaced without losing any water-shedding performance.

Cedar has natural oils and natural anti-fungal agents, which is why cedar trees can live over 1000 years. Besides pressure treating the cedar by the manufacturer before installation, it is difficult to improve on cedar's natural long-lasting properties. Do not use a topical treatment product that makes outrageous claims (such as 10-year effectiveness); makes fire-retardant claims; is a sealant, waterproofer or plasticizer; or contains unfortified linseed oil, diesel fuel or crank case oil. Topical solutions such as latex, butyl-, or silicon, "seal" or coat the surface of the cedar preventing it from "breathing". Anything used as a topical treatment should be labeled as a cedar roof treatment product or have a letter from the manufacturer stating that treating cedar roofs is an appropriate use for that product.

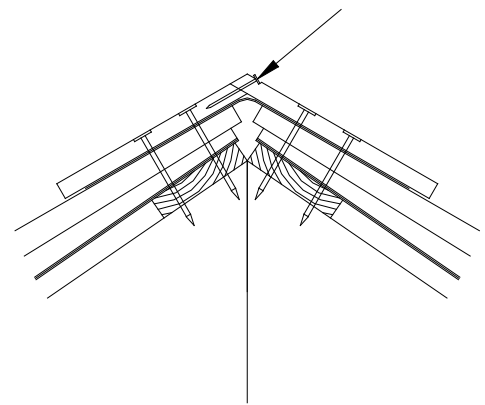

---

## **SECTION 5.c MOSS AND ALGAE CONTROL**

Moss and algae will grow wherever it can take hold on a cool damp surface. When the surface dries out these organisms become dormant and survive until the moisture returns. Rooftops in the temperate rainforest areas of British Columbia provide such conditions. Roof areas that are shaded by overhanging trees or other buildings provide longer periods of cool moisture that extends growth time and encourages a more rapid build up.

Aside from aesthetics a build-up of moss can impede the flow of water off the roof and, depending on the slope, eventually build up enough water to divert it under water shedding roof systems such as asphalt shingles, cedar, or concrete tiles etc. and into the building. On flat roofs the resulting ponded water can build up to a point where it causes a leak or structural damage.

How to remove moss and algae has been answered in a variety of methods involving physical removal, chemicals or a combination of the two. A quick tour of the internet shows a variety of businesses that

will perform a complete service, which is the easiest and safest approach. Moss and algae removal, like any other rooftop activity requires ladder and heights safety precautions before starting.

The first consideration to reduce moss and algae growth is to reduce the time of available moisture, when moss and algae can grow. These plants become dormant when dry but will restart growth when the conditions are favorable. This usually involves cutting back overhanging tree branches and removing excess debris such as leaves and twigs to facilitate drying. Removal of existing moss can also be done at this time with a broom and/or plastic scraper. Care must be taken to avoid damaging the surface of the roofing materials when doing this. Granules on asphalt shingles protect them from the sun and all materials can be broken if care is not taken when walking on, sweeping, or scraping. Damage to the materials or their surfacing will shorten the service life of the roof. Roofing product manufacturers and associations recommend not using power washing devices. The force of the water can remove the surface or break away pieces of material causing immediate leaks or shorten the service life of the roof system.

It is nearly impossible to physically remove all the moss roots and small pieces from a roof surface, and being quite hardy, the moss and algae will re-grow from whatever is left. A number of products can be used to kill the remaining plant material or discourage new growth.

#### **Zinc Sulfate; Zinc-Copper Sulfate mix;**

These are widely available in gardening and home improvement stores. They are usually applied as a powder but can be dissolved in water and sprayed with a basic garden sprayer. If applied as a powder the roof surface should be damp but not raining at that time. Application instructions and cautions from the manufacturer should be followed. These types of products release slowly and can be effective on their own for a year or more. Overspray onto adjacent plants and drainage into ponds etc. should be avoided.

#### **Bleach and Detergent solutions;**

Combinations of Trisodium Phosphate and chlorine bleach are widely used in varying concentrations. These kill the moss and algae quickly when applied from a garden sprayer. Concentrations used vary from 5 gallons of water and 1 gallon of bleach with 1 cup of TSP to 2½ gallons of water and 2½ gallons of bleach with 1 cup of TSP. Apply enough solution to thoroughly soak the roof area but avoid overspray onto adjacent garden areas etc. The roof surface will become more slippery as it is wetted so caution to start at the far end from the roof access is advised, avoiding walking on the wet surface.

#### **Organic Fatty Acids;**

Organic Fatty acids are a natural soap product that can be used to kill algae and moss. When used as directed it is safe around plants and pets etc. The product comes in a liquid concentrated form that can be diluted into a sprayer tank or used with a proportioning hose end sprayer. Most garden supply and home improvement stores carry these products.

#### **Zinc or copper strips and flashing;**

These metals when placed in strips just below the ridge cap or installed as a ridge cap flashing will react with the water running over the surface to produce a mild chemical solution that will reduce moss and algae growth for many years. Many asphalt shingle manufacturers now offer products with the granules having content of these metals. The effectiveness of strips placed near the ridge will vary with the surface area of the strip and the amount of water running over it. The affect of the strip on the moss and algae is usually good for at least 10 to 15 feet down slope. Packaged zinc strips with instructions are available in most home improvement stores. When installing zinc strips the fasteners through roofing materials should not be left exposed to avoid possible roof leaks.

## SECTION 6

# TECHNICAL INFORMATION

The information provided in this publication are articles compiled to assist consumers with specific roofing related topics.

Another excellent source for roofing information articles is the Roofing Consultants Institute website at [www.rci-online.org](http://www.rci-online.org)

---

### SECTION 6.a ROOF DECKS

#### *General*

The roof deck must be designed to serve two major functions:

1. As a structural component to transfer the weight of live and dead loads to supporting members. Live loads include construction equipment and workers, rain, snow, and ice. Dead loads include the deck itself, the roofing system, HVAC units and, possibly, landscaping. Most decks must also act as a diaphragm, transmitting wind or seismic lateral forces to the buildings structural framework.
2. As a suitable substrate to which the roof membrane or roof system is attached.

The roofing contractor is mainly concerned with the deck surface, which must be suitable for applying the roof system materials. Prior to the application of the roof system, the roofing contractor should inspect the deck to ensure it forms a suitable substrate, that it is smooth, straight, and free of "humps" and depressions. In addition, the roof deck must satisfy several other requirements:

It should provide positive slope to drain (required for a 5 year RGC Guarantee for new construction and for organic felt membrane systems when re-roofing). Positive slope to drain is attained when no standing water remains on the deck 48 hours after a rainfall stops. Where required, crickets and saddles should be provided to assist drainage. Slope can be provided by sloping the deck, or using tapered insulation boards or insulating fill (insulating fill is rarely used in B.C.). A minimum slope of 1:50 (1/4" in 12") is strongly recommended.

It should be dimensionally stable and capable of accommodating roof system component movement.

Deck deflections should be limited to 1/240 of the total span, but must conform to the Building Code. For plywood decks, RGC limits the allowable deck deflection to 1/360 of the total span to prevent differential edge movement. Concentrated, non-uniform construction loads should be considered during design. Drains should be located at points of maximum deflection whenever possible, not over columns or bearing walls.

Conduit applied on top of roof deck surfaces is not acceptable unless prior express written approval has been issued by RGC. If conduit is present on decks, the membrane substrate must be made smooth and even, to the satisfaction of the inspection agency. The last layer of insulation shall be over the top of the conduit. Detailed as-built drawings should be made to prevent conduit damage and safety risks to roofers, should the roof require replacement at a future date.

Prior to acceptance of the deck and the commencement of roofing, the roofing contractor should ensure that curbs, cants and blocking are installed by others.

## **Wood Decks**

Wood is a common construction material that has been used for many years because of its economy, ease of fabrication, lighter construction, and ready availability. Acceptable wood roof decks may include wood board decks, plywood decks, and, subject to restrictions, non-veneered wood decks (oriented strand board, waferboard, etc.). All types of wood decks should be roofed promptly after installation.

### **Wood Board Decks**

Wood board decks include tongue-and-groove, shiplapped, or splined boards or planks usually ranging from 19 mm to 89 mm (nominal 1" to 4") thickness. Also 38 mm (nominal 2") by various width boards, placed on end, can be spiked together to form a "mill deck". The thicknesses of the boards is determined by the anticipated loads and spacing of roof joists or trusses (consult Building Code).

Wood board decks should be of sound seasoned lumber, properly secured to supporting structure. The deck should form a firm smooth surface, free from knotholes, cracks, projections, depressions and other defects. Prior to the roofing contractor's acceptance of the deck, minor knotholes and cracks should be covered with securely nailed sheet metal (performed by others).

Wood board decks, especially mill decks, often have so many surface defects that a plywood overlay is desirable (9.5 mm (3/8") plywood is often acceptable). Where a plywood overlay is not required, a mechanically fastened base sheet or separator sheet is required for built-up roofs or fully-adhered bituminous or modified bituminous flexible roofing membranes. For non-bituminous flexible membranes (elastomeric or plastomeric membranes such as EPDM or PVC), a slip sheet or separator sheet should be installed according to membrane manufacturer's recommendations. Separation sheets, slip sheets, and mechanically fastened base sheets are installed to help relieve stresses in the membrane due to movement of the deck.

### **Plywood Decks**

Plywood roof decks consist of exterior type plywood mechanically fastened to the roof framing. The plywood panels should conform to CSA 0121, "Douglas Fir Plywood", CSA 0151, "Canadian Softwood Plywood", or CSA 0153, "Poplar Plywood", as per Building Code requirements.

For steep slope roofing (e.g. asphalt shingles), plywood thicknesses must – as a minimum – conform to Building Code requirements; however, the following minimum plywood thicknesses should be considered:

12.7 mm (1/2") for 400 mm (16") o/c supports

15.9 mm (5/8") for 600 mm (24") o/c supports

These thickness/span ratios will minimize deck deflection, especially with construction loads, and will provide a better surface for nailing as the bouncing effect of thin plywoods is reduced.

For low slope roofing (e.g. BUR), plywood must be minimum 12.7 mm (1/2") thick unless mechanically attached rigid insulation is installed prior to the roofing membrane. The minimum centres for supporting members are:

400 mm (16") for 12.7 mm (1/2") plywood sheathing

600 mm (24") for 15.9 mm (5/8") plywood sheathing



For low-slope roofing, differential edge movement and deflection in excess of 1/360 of the span must be prevented by:

- solid blocking under non-supported edges, and/or
- use of tongue-and-groove plywood with non-grooved edges supported by joists or solid blocking, and/or when rigid insulation is over the deck, properly sized and installed H-clips should be used on the unsupported edges.

Plywood roof sheathing should be installed with the surface grain at right angles to the roof framing, with end joints staggered.

Plywood decks receiving roofing directly applied to the deck should be attached using wood screws or nails which are especially resistant to pull-out or nail popping, particularly when using a single-ply membrane (i.e., use ring-type or ardox; smooth common nails are not acceptable). Nail popping is usually caused by a combination of thermal and structural movement and is especially critical where the membrane is directly adhered to the deck. All fasteners should have a corrosion-resistant coating (such as galvanizing). The structural suitability of the fastener is the responsibility of the design authority.

### ***Non-veneer Wood Decks***

Non-veneer panels are identified as waferboard or oriented strand board (OSB) panels, as opposed to plywood or veneered panels.

Non-veneer (O.S.B. or waferboard) panels are acceptable decks on low-slope roofing applications when an approved separation sheet or rigid insulation is mechanically attached before roofing is applied. (See Tab 4 System Data Sheets).

The use of non-veneered panels in steep slope applications with asphalt shingles applied directly to the deck is also not recommended by RGC, as there can be an increased chance of worker injury due to their slippery surfaces.

### ***Concrete Decks***

Concrete roof decks include decks that are cast-in-place or pre-cast, and structural or non-structural in nature. Although this roof deck category includes numerous variations (discussed later), many of the precautions involved with roofing over them are similar.

The finished surface of the deck should be smooth, level, and free of moisture or frost. All ridges or projections should be removed; and curbs, cants, blocking, and nailing strips should be installed where required prior to the roofing contractor's acceptance of the deck. With cast-in-place decks, special care must be taken to ensure that the deck is cured for 28 days and that the surface is dry. (A simple test for determining whether the deck is dry enough for roofing is to apply hot asphalt to the deck; if it foams or is easily peeled off after it cools, the deck is too wet.) Pre-cast decks may require joints to be "taped" or stripped-in with felts, and the joints, weld plates, and elevation differences to be feathered with grout.

Although some concrete decks are considered "nailable", insulation is most commonly attached by using hot asphalt over a primed deck. The asphalt is mopped to the deck and allowed to cool to the point where the insulation is not melted, but is still sufficiently bonded to the deck.

Built-up roof membranes can be directly adhered to both cast-in-place decks and, provided precautions are taken, pre-cast decks. Vented base sheets may be used to provide semi-adherence to the roof deck.

- Concrete roof decks include:
- Cast-in-place reinforced concrete

- Pre-cast concrete panels
- Pre-stressed concrete
- Lightweight insulating concrete
- Poured gypsum concrete

A cast-in-place reinforced concrete roof deck is produced by pouring concrete into formwork containing reinforcing steel bars or welded steel mesh. The surface of deck should be screeded and trowelled to provide a smooth, level surface. Caution should be exercised when using certain curing agents and techniques. Curing agents may not be compatible with roofing materials and some curing techniques do not allow the deck to dry sufficiently.

Pre-cast concrete-panel roof decks consist of manufactured panels designed to span between beams or load-bearing walls. They are available in the following cross-sectional shapes: single "T", double "T", solid slabs, hollow-core slabs, inverted channels, and tongue-and-groove planks. Metal plates may be installed to provide a welded structural connection and lateral bracing.

Pre-stressed concrete roof decks consist of concrete (usually pre-cast panels) that is pre-stressed using integral steel tendon reinforcement. The unit is compressed to counteract flexural tensile stresses which usually result in a cambered unit (a slight curve that results in the centre of the unit being higher than the supporting ends). The camber will usually flatten once the structure is loaded.

Lightweight insulating concrete roof decks and fills consist of concrete mixtures that have vermiculite or perlite as insulating aggregates, or they may also be produced by mixing a pre-generated foam with portland cement and water. This type of deck is usually designed for application over steel decks, corrugated metal forms, or bulb-tee or formboard systems. The concrete mixture is placed and screeded on site. Usually these mixes use a very high water/cement ratio and may require a lengthy cure time and a vented base sheet because of high moisture content. Vented base sheets provide a path for moisture vapour to vent to an appropriate point where the vapour may be released.

Poured gypsum concrete roof decks consist of a mixture of gypsum concrete, wood fibres or mineral aggregate, and water. The mixture is poured into formboards that contain welded or woven galvanized wire fabric. The formboards are left in place and may provide the finished interior surface.

### ***Steel Decks***

Steel roof decks are constructed of light gauge (usually 22, 20, or 18 gauge) cold-rolled steel sections (panels) that are usually galvanized. In cross-section the panels are ribbed, with the ribs usually spaced at 150 mm (6") on centre. The ribs provide the strength and rigidity of the panels. Steel decks are generally supported by open-web steel joist framing and are welded or mechanically-fastened to the framework. Steel deck panels must be properly aligned, squarely intersect walls, and provide a smooth level surface for roofing.

For insulated roof assemblies, a thermal barrier may be required to conform to Building Code or fire insurance-rated assemblies. This is usually required where the insulation is classified as combustible. Uninsulated systems require a levelling underlay for the membrane. Gypsum board may serve both purposes (thermal barrier & level surface).

Minimum thicknesses of insulations should be checked carefully to ensure that the material can safely span the flutes. The insulation or insulation overlay must be mechanically-fastened to the deck, unless it is a ballasted system.

### ***Corrosion Protection for New Steel Roof Decks***

When steel roof decks are specified, RGC recommends that the design authority specify the decking be factory-galvanized or factory-coated with aluminum zinc alloy for corrosion protection.

When specifying galvanized protection (in the section of the specifications addressing metal decking), the design authority should specify a coating that complies with ASTM A 525 Class G-60 or

Class G-90. A G-90 coating provides greater corrosion protection than a G-60 coating (the ASTM specification previously identified G-60 as "light commercial" and G-90 as "commercial").

When specifying aluminum zinc alloy protection (in the section of the specification addressing metal decking), the design authority should specify a coating that complies with ASTM A 792. An aluminum zinc alloy coating provides greater corrosion protection than a G-90 galvanized coating.

*Note:* The above recommendation applies to most buildings. However, in highly corrosive or chemical atmospheres, special care in specifying protective finishes should be taken, and individual deck manufacturers should be contacted.

### **Roof Expansion Joints**

Roof expansion joints are designed to prevent membrane splitting and ridging (caused by either movement of the building or movement of the roof assembly due to thermal expansion and contraction).

Roof expansion joints should be considered wherever:

- the type of deck changes
- additions connect to existing buildings
- expansion and control joints exist in the structural system
- separate wings of a building join (e.g. "L" or "T" configurations)
- interior heating conditions change
- differential movement may occur (e.g. parapet detail where the deck is not supported by the wall)

The location of roof expansion joints must be clearly indicated on the drawings and in the specifications, as the installation of wood blocking and cants is the responsibility of "others" and must be in place prior to the roofing contractor's acceptance of the deck.

### **Roof Divider/Control Joints**

Roof dividers (sometimes referred to as control joints or area dividers) are built on-site. They are designed to help control thermal expansion and contraction stresses in the roof system where no structural expansion joint has been provided in the building design. Roof dividers are especially useful for controlling stress concentration in the membrane, and should be considered (and may be required) on all fully-adhered roof membrane systems.

A roof divider is usually designed as two raised wood members attached to a wood base-plate that is securely anchored to the roof deck and then properly flashed with membrane and metal. Roof dividers should divide the roof into approximately equal, regularly-shaped areas. Ideally, roof dividers should be located at the high points of the roof, with drainage away from the divider on both sides, but **DRAINAGE MUST NOT BE IMPEDED BY THE ROOF DIVIDER.**

The location of roof dividers must be clearly indicated on the drawings and in the specifications, as the installation of wood blocking and cants is the responsibility of "others" and must be in place prior to the roofing contractor's acceptance of the deck.

*Note:* that the requirement for roof divider/control joints for flexible membranes differs, and must be evaluated on a product performance basis.

---

## SECTION 6.b VAPOUR RETARDERS

### *General*

Vapour retarders are used to retard the flow of moisture vapour from the interior of a building into the roof system. Moisture vapour flows outward by vapour diffusion and air leakage.

#### Vapour Diffusion and Condensation

A VAPOUR is the gaseous form of any substance, but it commonly refers to those gases, which exist as liquids or solids under normal temperatures and pressures. To fully understand the behaviour of vapours, a simple model should be considered: a sealed container of air with water at the bottom. The liquid molecules are almost as close together as with solid matter but they are not held in a rigid pattern. These molecules are in a constant state of thermal agitation due to its kinetic energy. (This motion is easily evidenced by placing a drop of dye or ink into a glass of water. It will diffuse relatively quickly into a uniform mixture). Some of the molecules near the water will break free (evaporate) due to this motion and diffuse within the air forming water vapour. The vapour molecules are still in a constant state of motion and will collide randomly with the container's surface, with each other, and with the remaining water. These collisions create a pressure on the surfaces known as VAPOUR PRESSURE; the greater the number of collisions, the greater the pressure.

If more heat energy is added to the container, more vapour molecules break free from the water to diffuse in the air. The air is said to be saturated when the number of molecules escaping the water equals the number colliding back into the water. In this state, a point of equilibrium has been reached and the air can hold no more vapour unless additional heat energy is added. Similarly, if the container is cooled, the thermal activity decreases, less vapour molecules break free than return to the liquid, and vapour molecules begin to condense into droplets on the sides of the container (condensation). Therefore, it can be stated that warm air can hold more moisture vapour than cold air.

The pressure exerted on the container by the air/vapour mixture is the sum of the air pressure and moisture temperature and the relative humidity. Temperature has the most effect as the pressure increases exponentially with raises in temperature and linearly with increases in relative humidity. When differences in vapour pressure exist on either side of a material, moisture vapour molecules will attempt to "flow" through the material and equalize the pressures. The moisture vapour molecules will flow at a rate dependent upon the pressure differential, the thickness of the material, and the material's permeance.

PERMEANCE is the measure of a material's ability to permit the flow of vapour. Permeance (SI) is measured in  $\text{ng}/(\text{Pa}\cdot\text{s}\cdot\text{m})$ , or nanograms per second for one meter thickness and one Pascal pressure difference. Permeance (ASTM standard) is also measured in grains of water (700 grains of water = 1 pound of water vapour) per hour for one square foot area and one inch of mercury (1" of mercury = 0.491 psi).

To fully understand how vapour behaves, RELATIVE HUMIDITY (RH) and CONDENSATION must be examined. When the water and air/moisture vapour mixture reach a point of equilibrium and the air is said to be saturated, as discussed earlier, the air is said to have a relative humidity of 100% for those temperature and pressure conditions. Humidity is a term used to describe the amount of moisture vapour in the air. Relative humidity is the ratio of the amount of moisture vapour actually present in the air to that amount which would be present if the air were saturated at that temperature. Relative humidity is expressed as a percentage, and is calculated as follows:

mass of vapour present

$$RH = \frac{\text{mass of vapour present}}{\text{mass of vapour if saturated}} \times 100$$

mass of vapour if saturated

If a quantity of unsaturated air is kept at a constant temperature and the moisture vapour is changed, the relative humidity will increase as moisture vapour is added and will decrease as moisture vapour content is kept constant. If the temperature is changed, the relative humidity will decrease as the temperature increases and will increase as it is cooled.

As the unsaturated sample is cooled, the point of saturation may be reached as the molecules lose the ability to remain separate and droplets will form. This is known as the DEW-POINT TEMPERATURE; i.e., the temperature at which a sample of humid air cools from its original temperature, becomes saturated, and condensation occurs.

In buildings located in moderate to colder climates, the conditions exist for problems with vapour diffusion and condensation. The building's interior is kept warm and humid while the exterior is colder and drier. This creates a vapour pressure differential and, as discussed earlier the moisture vapour will attempt to flow through the material which separates them: the roof and walls. Since heat and vapour flow tends to be upwards, the roof is the "benefactor" of most of the pressure. By insulating the roof, the problem of condensation on the roof deck surface has been eliminated, but not the pressure differential. The vapour pressure now may result in moisture vapour flow up into the insulation. As the moisture vapour travels closer to the exterior, the vapour cools and the dew-point temperature may be reached and condensation within the roof system can occur. Since the roof membrane is traditionally placed above the insulation the moisture is trapped within the system and can cause a roof failure and/or structural problems within the building. Severe condensation is a serious problem.

To calculate the relationships between relative humidity, vapour pressure, and temperature, a PSYCHROMETRIC CHART should be consulted. This chart will reveal the relevant vapour pressure and the temperature at which a given sample of mixed air/moisture will condense. Given this information and the design temperature and humidity for the building's location, the design authority can determine the vapour pressure differential and dew-point temperature, and determine the requirement for a vapour retarder, insulation value, etc.

### ***Air Leakage***

Although vapour diffusion may be a factor, the most common cause of moisture vapour condensing in a roof system is air leakage. Air leakage occurs through poorly sealed joints and through material imperfections, such as cracks and punctures. The major differences between air leakage and diffusion are the quantity involved and the causes, but the result is the same: moisture vapour condensing within the system. With air leakage, the quantity of water vapour is likely to be much greater than that with diffusion. Air leakage occurs due to differences in air pressure. As with vapour pressure, air tends to flow from areas of high pressure to areas of low pressure.

Air pressure differences resulting from temperature differences between inside air and outside air can sometimes result in a stack effect, similar to a chimney. This effect will cause infiltration of air at lower levels and exfiltration at higher levels: most notably, the roof. Wind will also add to the problem, resulting in infiltration on the windward side and exfiltration on the leeward side. Mechanical systems may also pressurize the building, causing exfiltration. All three factors add to the stack effect and create a large outflow of air trying to escape through the roof. The air pressure differences result in warm humid air flowing outward into the walls and roofs causing the moisture vapour to condense and leading to possible roof and other failures.

### ***Causes of Roof Failure***

Vapour that is allowed to flow upward through a roof system, whether through diffusion or leakage, may result in roof failure. Some of the common problems posed by moisture vapour are:

- condensation within the insulation, which can reduce or eliminate most insulation's the thermal resistance. The thermal conductivity of water is approximately twenty times that of air. Freeze-thaw cycling of the moisture may break down the insulation.
- absorbed moisture, which can contribute to the decay of organic roofing materials and insulation.
- trapped moisture, which can freeze and cause delamination of the membrane.
- condensation trapped within voids, which can expand with the sun's heat and create blisters.
- condensation which collects on the underside of the insulation and flows through joints or cracks in the roof deck, which can then leak onto suspended ceilings or into the roof assembly.

### ***Vapour Retarder Materials***

The purpose of a vapour retarder is to retard the flow of moisture vapour from the interior of the building into the roof system. The decision to use a vapour retarder is up to the design authority, as it relates to the design and occupancy of the building. The design authority should perform the necessary psychrometric calculations to determine the requirement for, and the permeance rating of, the vapour retarder.

The vapour retarder systems most commonly available are:

- bituminous vapour retarders
- laminated kraft paper vapour retarders
- self-adhered modified bitumen membranes
- the key to any vapour retarder is in its continuity; the vapour retarder must be sealed at all laps, penetrations, etc., to ensure continuity

Bituminous vapour retarder systems are commonly used and are usually either:

- two plies No. 15 felt, mopped
- an asphalt-coated base sheet with mopped foil laminate
- proprietary systems offered by flexible membrane manufacturers

Laminated kraft paper vapour retarders are usually composed of glass fibre-reinforced kraft paper. Factory Mutual may approve kraft paper laminated with fire-retardant adhesive for use in Class 1 construction. Asphalt is also used with this product to attach the laminated sheets to steel roof decks and to attach insulation to the vapour retarder. Kraft paper laminated with asphalt adhesive must be applied with a fire-resistant adhesive that meets Factory Mutual requirements for Class 1 construction.

The claimed principal advantage for kraft paper retarders is that they possess greater strength than common felts due to glass fibre reinforcement.

Self-adhered modified bitumen vapour retarders are composed of a synthetic sheet and compatible SBS and asphalt adhesives. The self adhesive bitumen is used to adhere the sheets to the primed substrate and seams between sheets.

### ***Vapour Retarder Design for High-Humidity Building Interiors***

RGC recommends that when design authorities specify roof assemblies over high-humidity building interiors that careful consideration is given to the type and construction of the vapour retarder.

Because great amounts of moisture are released into interior environments of high humidity buildings [swimming pools, commercial laundry facilities, large aquariums, paper mills, etc.] there is a high degree of risk that extreme amounts of moisture will accumulate within the roof assembly when an effective vapour retarder is not included.

Vapour retarders for high humidity facilities should have a perm rating as close to zero as possible, be durable, multi-layer membranes that are effective in preventing vapour drive into the roof systems from the interior of high humidity environments.

Thin, lightweight, single-layer kraft paper vapour retarders are prone to damage during installation of roof assemblies and are therefore not recommended for use over high humidity building interiors.

## **SECTION 6.c ROOF DECK INSULATION**

### ***General***

Buildings are designed to provide an interior environment (or shelter) that is not governed by the exterior environment. The roof is a fundamental component of this design and must perform several functions. As part of the roof assembly, properly designed and installed roof insulation provides the following benefits:

It reduces energy costs and provides a comfortable interior environment by resisting heat loss.

It can prevent condensation occurring on interior surfaces by raising the dew point above the roof deck.

It generally provides a more suitable substrate for the membrane than does the roof deck.

It reduces deck component temperature fluctuations and, therefore, the expansion and contraction of the deck.

The following disadvantages have been associated with "conventionally" placed roof insulation (i.e., insulation placed between the membrane and the roof deck):

In hot weather the insulation resists heat flow into the building, thereby increasing the surface temperature of the membrane. This accelerates the aging (or oxidization) process of the membrane. In built-up roofing this can result in either the hardening and embrittlement of the bitumen, alligating, or splitting.

By eliminating the problem of interior condensation, the insulation creates the possibility of moisture (vapour or liquid) trapped within the roof system. This can lead to numerous problems and may create the need for a vapour retarder.

The frequency of thermal expansion and contraction in the membrane may be increased, thereby increasing the stresses on the membrane which can result in membrane splitting.

A protected membrane roof assembly (PMR) may eliminate some of the possible disadvantages, but this assembly has its own characteristics.

### ***Theory***

The function of insulation is to retard the flow of heat energy. Heat may flow in three ways:

- **Conduction** – the transfer of heat energy through direct contact molecule to molecule.

- **Convection** – the transfer of heat energy by the movement of liquid or gas.
- **Radiation** – the transfer of heat energy by electromagnetic waves.

Through the use of solid materials such as insulation in the roof assembly, the mode of heat transfer can be considered purely conductive. The rate at which a material allows heat transfer by conduction is referred to as its thermal conductivity (K or KSI). Conductivity is the basic unit of heat flow.

Thermal conductance (C or CSI) refers to the conductivity of a specific thickness of a material. The formula for determining the thermal conductance of a material is:

$$C = \frac{K}{\text{unit thickness}}$$

Thermal resistance (R or RSI) refers to a material's resistance to heat flow which is the reciprocal of its thermal conductance (C or CSI). Thermal resistances are additive and are therefore useful in design calculations. The formula for determining the thermal resistance of a material is:

$$R = \frac{1}{C} \quad \text{OR} \quad \frac{\text{unit thickness}}{K}$$

The overall coefficient of heat transfer (U) is the time rate of heat energy flow for a complete assembly, including air films. To calculate the U-value, take the reciprocal of the additive total of the resistance, for example:

$$U = \frac{1}{R1 + R2 + R3 + \text{etc.}}$$

The units for these quantities can be either metric or standard. Metric units usually include "SI" (Système International d'Unités) after the unit symbol.

Thin air at inside and outside surfaces provides thermal resistance. Wind reduces outside air-film thickness, thus reducing its thermal resistance (R-value) as wind speed increases. The thermal resistances of indoor air films vary with the direction of heat flow. A ceiling air film has greater thermal resistance against downward heat flow because upward heat flow is accompanied by convective currents that disturb the air film and reduce its resistance to conductive heat flow.

If the space between the structural roof deck and the suspended ceiling is used as a return-air plenum, only R-values above the plenum should be considered.

### **Installation**

The following procedures for installing insulation in roof systems should be followed:

1. On steel roof decks, deck flutes and felts should normally run in parallel alignment and be perpendicular to the roof slope.
2. On steel roof decks, insulation boards should be firmly supported by steel deck flanges. When only one layer of insulation is installed, the long dimension of insulation boards should not cantilever over steel deck flutes.
3. A staggered double-layer insulation system may provide the following benefits:
  - a. elimination of thermal bridges, where leakage of heating or cooling energy may occur.



- b. reduced ridging, by eliminating through-joint migration of moisture vapour into the membrane, and subsequent deformation.
  - c. reduced ridging and splitting in the roof membrane.
4. The edges of insulation boards should be square, flush and have moderate contact with the edges of adjacent insulation boards. End joints between adjacent insulation boards should be staggered.
  5. For heat sensitive insulations and heat insensitive foamed insulations, RGC Guarantee Standards should be consulted for fibreboard overlay requirements for 5 year RGC Guarantee requirements.
  6. The specifier should not simply reference the thermal performance for a roof assembly by specifying the total R-value. The generic type, thickness, C-value, and applicable standards of the insulation required for application should also be specified.

### ***Desirable Properties***

Ideally a roof insulation would provide the following physical properties:

1. Compatibility with Asphalt/Adhesives: it would not have an adverse chemical reaction upon contact with asphalt/adhesives used with the roofing system.
2. Compatibility with Roof System Components: it would be compatible with the other components of the roof system. This is of special concern with flexible membranes (bituminous or non-bituminous) and the solvents, adhesives, application methods, etc. involved in their application.
3. Resistance to Thermal Conductivity: the lower the thermal conductivity, the less thickness of insulation is required to obtain the desired thermal resistance.
4. Resistance to Fire: it would not support combustion and would comply with the accepted fire rating.
5. Resistance to the Effects of Moisture: it would not be adversely affected by moisture vapour and free water.
6. Resistance to Cell Deterioration: it would be of a material that is durable and not subject to deterioration.
7. Resistance to Impact: it would be resistant to impact damage – providing rigidity and strength; and of sufficient density to provide a workable surface.
8. Dimensional Stability: it would be unaffected by varying moisture and temperature conditions, and resistant to thermal cycling.
9. Unaffected by Asphalt Application Temperatures: it would not "burn out" or deform due to the application temperatures of asphalt.
10. Stable K-value: the thermal conductivity would remain stable and would not drift higher with age.
11. Attachment Capability: its surfaces would accommodate secure attachment by traditional methods (roofing nails, or screws and plates).

The remaining sections will discuss some of the roof insulations available in British Columbia. This includes generic information on the insulation type, and product information for some of the RGC Accepted Materials. The generic information will discuss the properties of the materials relative to their use and to similar materials. The product information that has been included is taken from referenced publications.

## Tapered Roof Insulation Systems

Tapered roof insulation systems are generally available in three forms:

- Field-sloped lightweight insulating concrete roof fill
- Field-tapered perlite insulation boards
- Factory-tapered insulation boards

For a discussion of field-sloped lightweight insulating concrete roof fill systems see Tab 3.3, Roof Decks.

Field-tapered perlite insulation board systems consist of multiple layers of square-edged perlite boards that are tapered by cutting or grinding in the field.

Factory-tapered insulation board systems are the ones most commonly used because they are inexpensive and easy to use. The insulation boards can be tapered to provide slopes of 1:200 (1/16" in 12") or greater. The following types of insulation are factory-tapered:

- Rigid Fibreglass
- Extruded polystyrene
- Expanded polystyrene
- Polyurethane
- Polyisocyanurate
- Fibreboard

## Composite Board

Composite board roof insulation products consist of an insulation bonded with another insulation and/or a variety of other products (typically fibreboard, perlite, gypsum, etc.) to form a unified, multi-layered insulation board. The top and bottom surfaces of the board may be impregnated and/or coated with asphalt (or other binders), and covered with facing materials such as roofing felts, foils, kraft paper, etc. Composite board insulation is primarily manufactured for use on steel roof decks.

The properties and performance of composite board roof insulation varies with the components of the board. Generally, the boards are manufactured to provide some of the following properties and advantages:

- Compatible with asphalt,
- Resistant to thermal conductivity,
- Resistant to fire,
- Resistant to the effects of moisture,
- Resistant to cell deterioration (durable),
- Resistant to impact, and/or
- Unaffected by asphalt application temperatures (no overlay may be required).
- The possible disadvantages and precautions involved in the use of composite board insulations include:
  - Complexity of manufacture and dissimilar materials,

- Sometimes expensive, and
- Limited availability.

### **Glass Fibreboard (Fibreglass)**

Glass fibreboard roof insulations are composed of fine glass fibres compressed into rigid insulation boards. These boards are most commonly available top-surfaced with a glass fibre-reinforced asphalt and kraft paper. This provides a suitable surface for directly mopped bituminous membranes and for some flexible membrane roof systems. In addition, boards made of glass fibres bound in a resinous binder are available either top-surfaced for bituminous roofing, or plain for use under ballasted membrane systems.

Glass fibreboard roof insulation may provide the following properties and advantages:

- Compatible with asphalt,
- Compatible with most roof system components,
- Resistant to thermal conductivity,
- Resistant to fire,
- Resistant to the effects of moisture,
- Resistant to cell deterioration (durable),
- Resistant to petroleum solvents,
- Resistant to impact (if top-surfaced),
- Resistant to thermal cycling (dimensionally stable),
- Unaffected by asphalt application temperatures (no fibreboard overlay required),
- Stable K-value (the thermal conductivity does not change with aging),
- Conforms to minor deck irregularities, and/or
- Retains roofing nails (first layer in a two-layer application only).

The possible disadvantages or precautions involved in the use of glass fibreboard insulation include:

- The kraft paper facing may change dimensionally if allowed to absorb moisture (protect from weather prior to application), and/or
- Heavy equipment may compress the insulation and cause delamination of the membrane.
- Glass fibreboard roof insulation should meet or exceed CAN/CGSB-51.31-M84.

### **Extruded Expanded Polystyrene Foam**

Molten polystyrene and a blowing agent HCFC (142B) are mixed, under pressure, in an extruder. As this solution is extruded through an orifice into ambient temperature and controlled conditions, the blowing agent vapourizes causing the polystyrene to expand approximately 30 times its original size. The continuous extrusion process produces boards with a surface "skin" and closed cell structure and, for this reason, has been used extensively for protected membrane roof assemblies. The rigid insulation boards are expanded to a specific thickness during manufacture and have an approximate density of 32 kg/cu. m (2 lb/cu.ft.).

Extruded expanded polystyrene foam roof insulation is combustible and, when used on steel decks or over a roof that is subject to fire exposure from below, a fire-rated underlayment or thermal barrier

(such as gypsum board) may be required between the roof deck and the insulation (consult Building Code and insurance requirements).

Extruded expanded polystyrene roof insulation is manufactured to CAN/ULC-S701 standard and is currently available in three types (depending on physical properties) and in four forms, as follows:

- Type 4 for use on conventional or protected membrane roofing systems
- Type 4 with a factory-applied latex-modified concrete topping for protected membrane roofing systems
- Type 3 for use on conventional roof systems
- Type 2 for use on conventional roofing systems (density of 24 kg/cu.m [1.5 lb/cu.ft])

Extruded polystyrene roof insulation provides the following properties and advantages:

- Compatible with asphalt
- Resistant to the effects of moisture
- Resistant to cell deterioration (durable)
- Resistant to impact
- Resistant to thermal conductivity
- Stable K-value

The possible disadvantages or precautions involved in the use of extruded polystyrene roof insulation include:

- Flammable (combustible)
- Affected by solvents (i.e. adhesives and cleaners used for single ply membranes)
- Heat sensitive (requires an insulation overlay, such as fibreboard, to prevent "melting" [burnouts] from hot asphalt)
- Will not retain nails (requires screws and plates)

### **Expanded Polystyrene Foam**

Third Party Certification: RGC welcomes and accepts the industry recommendation presented by all EPS manufacturers currently active in the B.C. market to require third party certification of the EPS products meeting CAN/ULC-S701-97 (formerly CAN/CGSB-51.20-M87) requirements. It is understood that such a certification program requires annual inspections/recertification by an independent testing lab.

Molten polystyrene and a blowing agent are mixed and formed into uniform closed-cell structures ("beads"). These are later expanded up to 40 times by steam in a pre-expander. (The amount of expansion determines the density and, therefore, the thermal conductivity of the final product.) The expanded beads are stabilized in curing bins, fused into a billet in a block mold, and cut into the desired size, shape and thickness. This process produces rigid boards of interconnecting closed cells of densities varying from 16 to 48 kg/cu.m (1 to 3 lb/cu.ft). Expanded polystyrene insulation is commonly referred to as "beadboard" or "popcorn".

Expanded polystyrene roof insulation is presently manufactured to the CAN/ULC-S701-97 (formerly CAN/CGSB-51.20-M87) standard and is available in four types, depending on the physical properties of the material. Basically, the strength (tensile, compressive, flexural, and shear) and thermal resistance

properties increase, and the water vapour permeance and water absorption properties decrease from Type 1 to Type 4.

*Note:* Type 4 is usually, if not always, extruded.

Expanded polystyrene foam roof insulation is combustible and, when used on steel decks or over a roof that is subject to fire exposure from below, a fire-rated underlayment or thermal barrier (such as gypsum board) may be required between the roof deck and the insulation (consult Building Code and insurance requirements).

Expanded polystyrene foam roof insulation provides the following properties and advantages:

- Compatible with asphalt
- Resistant to the effects of moisture
- Resistant to cell deterioration (durable)
- Resistant to impact
- Resistant to thermal conductivity
- Stable K-value (the thermal conductivity does not change with aging)

The possible disadvantages or precautions involved in the use of expanded polystyrene roof insulation include:

- Flammable (combustible)
- Affected by solvents (i.e. adhesives and cleaners used for single-ply membranes)
- Heat sensitive (requires an insulation overlay (such as fibreboard) to prevent "burnouts" from hot asphalt)
- Will not retain nails (requires screws and plates)
- Dimensional instability may result from improper curing at the factory.

### **Polyisocyanurate Foam**

Polyisocyanurate is a closed-cell rigid foam material. The insulation boards are manufactured with asphalt-saturated felt or glass fibre facer sheets on the top or bottom of the foam core. In some cases the foam core is reinforced with glass fibre to provide additional fire resistance and greater dimensional stability.

Polyisocyanurate foamboard roof insulation is presently manufactured to two standards:

- CGSB 51-GP-21M applies to unfaced polyisocyanurate rigid insulation boards intended for applications where the continuous use surface temperature does not exceed +110°C (+230°F). This standard establishes one type (Type 4) and three classes (Class 1, 2 or 3) of polyisocyanurate insulation. The type is determined by the physical properties of the material and the class is determined by its surface burning characteristics.
- CAN/CGSB-51.26-M86 applies to faced polyisocyanurate rigid insulation boards intended for applications where the continuous use temperature is within -60°C to +80°C (-76°F to +176°F). This standard establishes four types (Type 1, 2, 3, or 4), four facing categories (Facing 1, 2, 3, or 4), and two surface burning characteristic classifications (surface burning characteristic "a" or "b"). The type is determined by the physical properties of the material, the facing is determined by the product the insulation is foamed between, and the surface burning characteristic is derived from the final product's flame spread classification.

RGC Guarantee Standards require that polyisocyanurate insulation manufacturers clearly identify the manufacturing date on product labels.

Polyisocyanurate insulation provides the following properties and advantages:

- Compatible with asphalt
- Compatible with roof system components
- Resistant to the effects of moisture
- Resistant to cell deterioration
- Resistant to impact
- Resistant to thermal conductivity
- Resistant to fire
- Resistant to thermal cycling (dimensionally stable)
- Unaffected by hot asphalt
- Retains mechanical fasteners

The possible disadvantages or precautions involved in the use of polyisocyanurate foam insulation include:

- Requires an insulation overlay (fibreboard or retrofit board) to prevent potential asphalt blistering
- Aged thermal resistance should be used for design calculations
- Felt skin may change dimensionally if exposed to weathering (provide protection prior to installation)
- Heavy equipment may compress insulation, causing deflections and de-bonding of the membrane
- Will not retain nails (requires screws and plates)

### **Fibreboard Roof Insulation**

Fibreboard insulation is composed of wood, cane, or other vegetable fibres and waterproofing binders. A water slurry containing the wood fibres and waterproofing binders is deposited onto a moving screen. The water drains through the screen and the remaining mass is heated in an oven or dryer to produce the finished product. Fibreboard roof insulation is produced in several forms:

- Plain
- Impregnated with asphalt or petroleum based paraffin
- Coated with asphalt

Fibreboard Roof Insulation that is adhered in a roof assembly with hot asphalt or asphaltic-based adhesives must have an asphalt coating on the top and bottom surfaces (minimum coated two sides) to meet RGC Guarantee Standards. Fibreboard for use as roofing insulation is manufactured to meet or exceed the requirements of CAN/CSA A247-M86 (Insulating Fibreboard), Type I (Roof Board).

Fibreboard roof insulation provides the following properties and advantages:

- Compatible with asphalt
- Compatible with most roof system components
- Resistant to thermal conductivity

- Resistant to cell deterioration (durable)
- Resistant to impact
- Resistant to thermal cycling (dimensionally stable)
- Unaffected by asphalt application temperatures (no overlay required)
- Stable K-value (the thermal conductivity does not change with aging)
- Retains roofing nails

The possible disadvantages or precautions involved in the use of fibreboard insulation include:

- Flammable (Combustible)
- Absorbs moisture (protect from the effects of weathering)
- Low thermal values
- Organic in nature and will rot on exposure to moisture.

## SECTION 6.d VENTILATION

### General

This section of the RGC Roofing Practices Manual provides general information on the benefits, types of vents and BC Building Code Requirements for attic and roof space ventilation.

### Benefits of Attic Ventilation

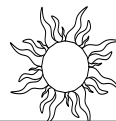

#### Attic Ventilation During Hot Weather

##### Unvented Attic

Roof surfaces can reach temperatures in excess of 170° C. Radiant heat penetrates through roofing, increasing attic and living space temperatures.

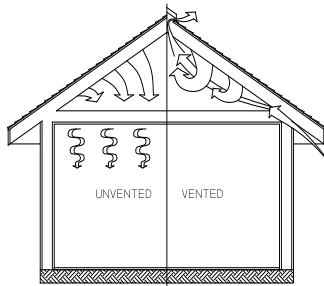

##### Vented Attic

Proper ventilation removes heat by causing air to move through the attic, keeping both the attic and living space cooler.

#### Attic Ventilation During Cold Weather

##### Unvented Attic

Moisture rising up through living space condenses in the attic, producing moisture on wood framing, insulation and roofing.

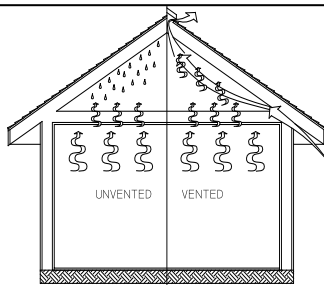

##### Vented Attic

Proper ventilation allows moisture to escape as fresh, dry air moves through the attic.

## Types of Pitched Roof Attic Vents

### Natural Air Flow Ventilators

#### Plastic Air Flow Vents

Acceptable plastic vents must conform to CSA – A93 –M82 (R 1992) or ICBO #4159. Vents must have a minimum 75 mm (3”) flange on the up-slope side and a minimum 50 mm (2”) flange on the remaining three sides.

Continuous ridge air vents must provide a minimum of 50 mm (2”) of flashing flange to overlap roofing material on each side of the roof ridge

Plastic Continuous Ridge Air Vent

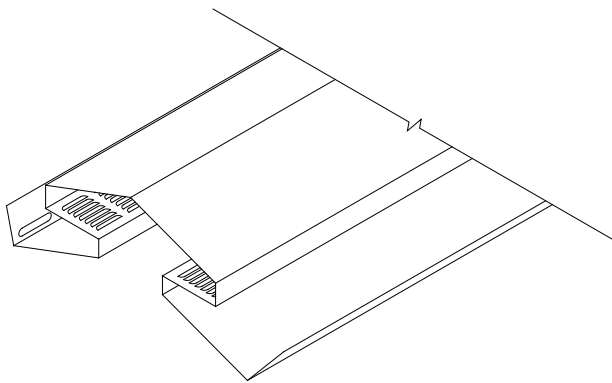

Plastic Air Flow Vent

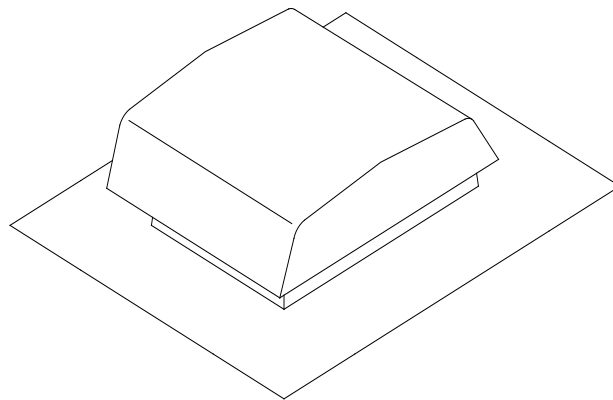

#### Metal Air Flow Vents

Acceptable metal vents must have a minimum 100 mm (4”) flange to receive roofing on all sides and a minimum vertical sealed height of 75 mm (3”). All seams are to be fully soldered or welded. Galvanized steel must be a minimum of 26 gauge and aluminium must be a minimum of 20 gauge. Ridge vents must provide a minimum of 50 mm (2”) of flashing flange to overlap roofing material on each side of the roof ridge.

Metal Ridge Air Vent

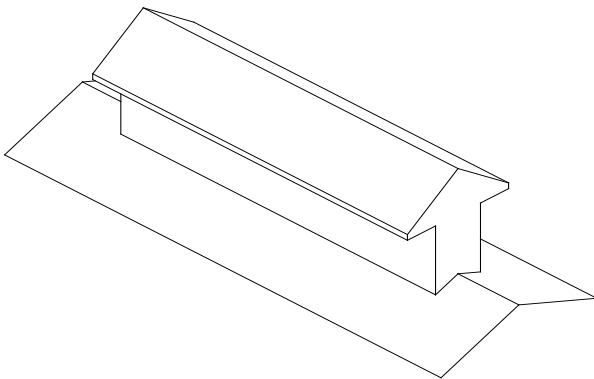

Metal Air Flow Vent

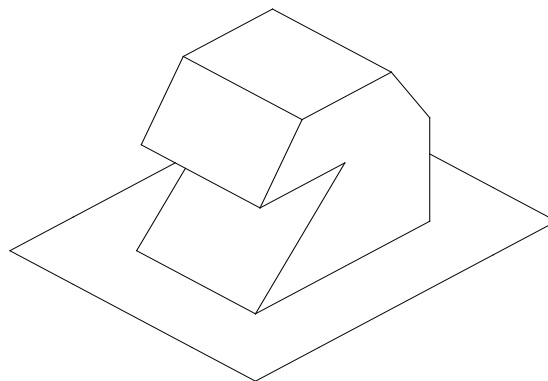



## Attic and Roof Space Ventilation

Requirements for Residential and Small Buildings (BC Building Code Section 9.19)

### Continuous Ridge Vent and Soffit Ventilation

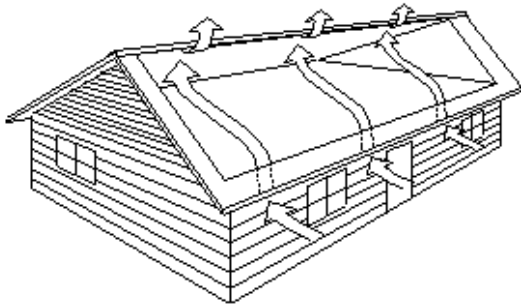

Where insulation is installed between ceilings and the underside of roof sheathing, space shall be provided between the insulation and roof sheathing, and vents shall be installed to permit the transfer of moisture from the space to the exterior.

(See Section 9.19 BC Building Code)

Vents shall be in conformance with CAN3-A93 natural ventilators for buildings and shall be designed to prevent the entry of rain, snow and insects.

### Gable End Vents and Soffit Ventilation

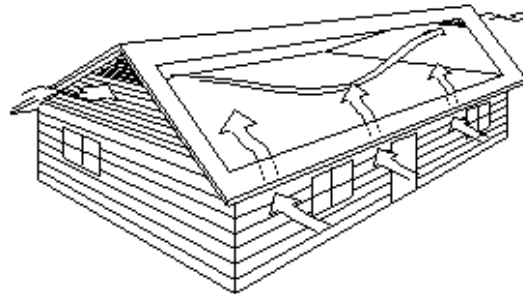

Ceiling insulation shall not be installed in a manner that will restrict free flow of air through roof vents or through any portion of the attic or roof space.

The unobstructed vent shall be not less than 1/300 of the insulated ceiling area. On roofs sloped less than 1:6 (2" in 12"), that are constructed with roof joists; the vent shall not be less than 1/150 of the insulated ceiling area.

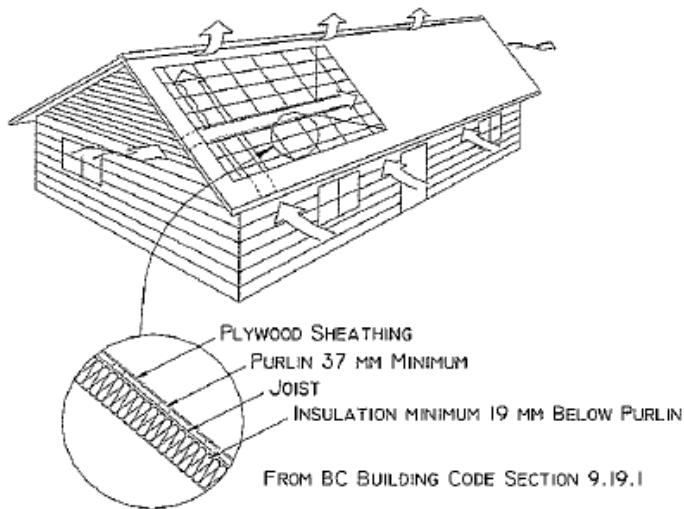

Spaced Purlins provide air space.

Where each joist space is not separately vented, roof joist spaces shall be interconnected by installing purlins not less than 38 mm (1 1/2 ") by 37 mm (1 1/2 ") on top of the roof joists. Not less than 63 mm (2 1/2 ") of space shall be provided between the top of the insulation and the underside of the roof sheathing.

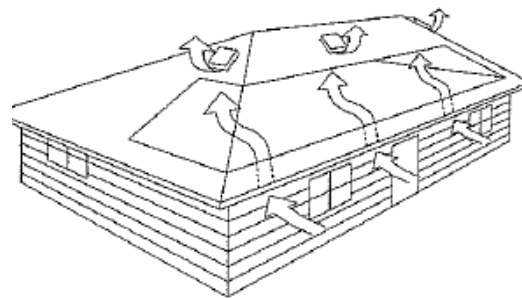

Vents may be roof, eave or gable end type or any combination thereof, as long as adequate ventilation is provided. The vents must be distributed uniformly on opposite sides of the building.

Not less than 25% of required vent openings shall be located at the top of the attic or roof space, and not less than 25% of the required openings shall be located at the bottom of the space.

The lower portion of the mansard or gambrel style roofs does not need to be ventilated. The upper portion requires ventilation as noted above.

## SECTION 6.e METHODS FOR GRANULE LOSS REPAIRS

### ON MINERAL SURFACED ROOFING

Jim Watson, PRC, RRO

RCABC Guarantee Corp. (RGC) Technical Manager

#### Introduction

An investigation is being conducted at the RCABC Roofing Institute in Langley, to identify effective methods and products to repair granule loss on mineral surface modified bituminous roofing membranes that was prompted by concerns raised by building owners about both the appearance of granule loss and the possibility of not receiving the expected serviceable life from roof membranes due to deterioration as a result of excessive granule loss.

Loss of membrane granules may result from poor granule embedment during manufacture, excessive foot traffic, wind scouring, overheating during application and mud caking in ponded locations, among other things. A severe granule loss problem on numerous roofs in Victoria, British Columbia, is a result of bird droppings with a high acid content caused by one of the birds' major food sources, wild cherries.

#### Initial General Observations



Figure 1

A preliminary investigation was completed in 1999 in order to determine the scope of our present study. Products and methods used by the Roofing Industry to repair granule loss were investigated. Replacing cap sheets or resetting new granules on reheated membrane or in cold applied mastics appear to be the methods most often used to repair granule loss. On-site observations, as well as tests carried out at the Roofing Institute, indicate that reheating membranes to set new granules generally results in poor granule adhesion as they tend to be displaced by normal weathering in a short period of time. Finally scorching or discolouration of surrounding granules often occurs during the reheating process.

Cold applied bituminous mastic repairs provide better granule adhesion, although mastics are difficult to apply to precise locations. The mastic method results in a build up of mastic on the membrane and is not practical for large areas. Furthermore, mastic repairs have a tendency to peel and curl at the edges as the mastic dries out. Finally, over time, granules tended to sink into or wear off the surface of the mastic leaving a visible dark spot that may, especially on light coloured membranes, be an aesthetic concern.

### **Alternative Granule Adhesive Identified**

A number of products used in the roofing industry were investigated, including mastics, roof coatings, and primers. One product group, adhesive primers used with self adhesive membranes, demonstrated superior adhesive qualities with little build up or negative effects on the membrane. The primers are extremely easy to apply by paintbrush or paint roller (See Figure 1) and can be sprayed. Loose granules were simply broadcast by hand into the wet adhesive primer and left to dry (See Figure 2). The primers initial set drying time is 30 minutes, with an additional 1½ hours to set thoroughly.

Initial tests were so encouraging that a similar primer from Soprema Inc., Elastocol 700 was tested, with very similar results.

The primers investigated are synthetic rubber based adhesive primers designed for use with self-adhesive membranes. The chemical composition of the primers is: toluene, naphtha, hydrocarbon resin aromatic modified, styrene-butadiene copolymer and styrene-isoprene copolymer.



Figure 2

### **Field Performance and Weathering**



Figure 3

Two samples of each manufacturer's primer with granules were prepared and have undergone weathering tests at the Roofing Institute (See Figure 3). The samples have weathered on a roofing institute training module for over two years and the results to date are excellent.

#### **Test Results**

The self-adhesive membrane primers tested appear to be excellent products for the repair of granule loss. The products are easy to apply and are not expensive.

A report to RCABC was received from Bakor Inc. on the results of accelerated weathering and mineral surface abrasion tests that were carried out at their laboratory. The report confirms that their Blue Skin Ultra adhesive primer used to

repair granule loss performs well without negative effects to the membrane and is suitable for use with their modified bituminous membranes. Soprema Inc. also confirmed that their Elastocol 700 adhesive primer for self adhesive membranes is suitable to repair granule loss on their modified bituminous membranes.

The results of natural weathering tests prepared at the Roofing Institute and the results of the tests carried out on these primers by manufacturers and the successful repairs carried out on numerous

RGC Guarantee jobs to date confirmed our original findings. The adhesive primers appear to be an improved alternative method for the roofing industry to repair granule loss for both small and larger areas on mineral surfaced roofing.

**Caution:** Ask for the membrane manufacturer's approval prior to using adhesive primers for granule repairs.

**Reference:**

ASTM D4977-98D Standard Test Method for Granule Adhesion to Mineral Surfaces Roofing by Abrasion.

Adhesive Primers:

- Bakor Inc. – Blueskin Ultra Primer
- Soprema Inc. – Elastocol 700

## SECTION 6.f RIDGING AND WRINKLING OF MODIFIED BITUMEN ROOF MEMBRANES

Modified bituminous roof membranes have been installed in Canada since the late 1970's. Since that time they have grown in popularity to command a significant share of the commercial/industrial roofing market. These membranes carried with them, however, an unrealistically high expectation for aesthetic perfection. As a result, controversy has arisen regarding the cause and performance consequences of wrinkles and ridges in these roofing membrane systems.

Building owners and their representatives (architects, engineers, roof consultants, etc.) are concerned about the impact of these wrinkles and ridges on the performance of their roofs. Roofing contractors are concerned with the claims that wrinkling and ridging are always the result of incorrect installation practices. And, of course, manufacturers are not happy when they are told that their prescribed application methods are too restrictive. This insert is intended to be an objective discussion of the wrinkling and ridging of these membranes and will provide information to minimize their occurrence.

### GENERAL

Much of the wrinkling and ridging that occurs is only cosmetic; many of these phenomena can be prevented during application. Some of the aesthetic problems with modified membranes are inherent physical properties of the materials or substrate. These materials, once wound into rolls will, due to their "memory", prefer to stay in a rolled position. Also, the most popular reinforcing for these membranes is polyester, which is heat sensitive and can stretch. For this reason, over-torcing and rolls that will not roll or lay straight are problems that must be addressed. The following are the most common examples of ridges and wrinkles found in modified bitumen roof membranes.

### WASHBOARD APPEARANCE

Washboard appearances are undulations across the sheet width. They usually occur in large numbers, are fairly evenly spaced and are at right angles to the application direction.

They are most often caused by the uneven stop/start of the roll during application, or an uneven build-up of bitumen in front of the roll combined with the weight of the roll sinking into the soft bitumen.

They are most predominant on hard substrates such as concrete or plywood.





If the edge lap is solidly sealed, this washboard appearance will have no effect on roof performance and no repairs will be needed.

### **CROSS DIMENSIONAL WRINKLE**

These wrinkles are found to run across the width of the roll, although they do not appear as regularly or exactly at right angles to the application direction as in the washboard effect.

One of the causes of this type of wrinkle is the attempt to straighten the roll during application. This may result in a "fish mouth" opening at the side lap of the membrane. If these appear in the base sheet and are not corrected, they will telegraph through to the surface and be visible once the cap sheet is applied. To avoid this, the rolls should be carefully aligned and not kicked out into position. If a roll of material does run off line and a wrinkle begins, stop the operation, cut the roll and cut out the wrinkle. Restart the roll as you would for built-up roofing felt.



Another cause of cross-dimensional wrinkles is the insufficient relaxation or conditioning of the rolls of membrane. The "memory" in these rolls, particularly for mopped base sheets, exaggerates this problem if the membrane is applied at temperatures below five degrees Celsius (5° C or 41° F). The rolls of material will begin to stiffen and will not tend to roll as easily as in warmer temperatures. One way to help prevent this is to store the rolls in a heated environment just prior to application. We all know, however, this is extremely difficult when working on projects where a warm storage area is not available. So, another way to condition these base sheet rolls during application is to lightly heat the underside of the rolls with a propane torch as they are being applied into a mopping of hot asphalt.

The other important factor to remember is that the asphalt used to adhere the sheet, with a mopped system, should be a minimum 205 degrees Celsius (205° C or 400° F) at the point of application to ensure a good bond of the membrane. The practice of slightly heating the sheet while it is being mopped has proven, in many areas, to be successful, as it will also help to reheat the mopping asphalt used for adhesion.

If these wrinkles appear after the sheet has been applied and they project out to affect the side lap of the sheet they should be cut, removed and a patch installed over the area prior to proceeding. A "fish mouth" should never be left in either the base or the cap sheet.

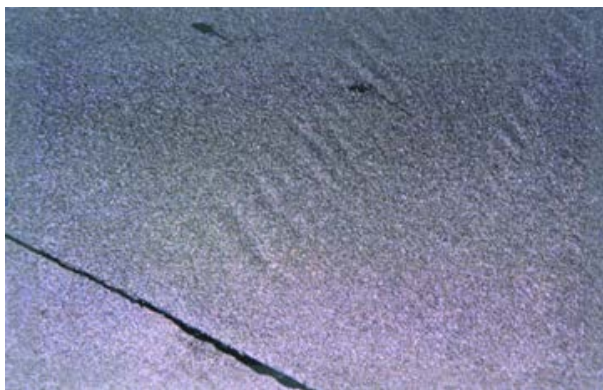

### **LONGITUDINAL WRINKLES**

There are two types of wrinkles that fall into this category and they are limited to torch applied systems only.

One is a short wrinkle that runs parallel to the length of the roll. This is most often caused by over torching (too much heat applied to the membrane during application) which causes the polyester reinforcing in the sheet to distort. This over-torching can occur by directing the torch too close to the sheet or by not moving the torch in a smooth and fluid motion.

Another cause of these wrinkles is insufficient backside coating of the sheet during manufacture. If the coating is not thick enough or uneven, inadequate protection will be provided for the reinforcing fabric

during the torching application, and distortion may occur. Any suspected material deficiency should be thoroughly investigated before work resumes.

Another type of longitudinal wrinkle is usually found to run in line with the side laps of the underlying base sheet. If asphalt, in a mopped base sheet application, is allowed to bleed out onto the polyethylene film on top of the adjacent roll and a cap sheet is torched, this bleed-out can build up and cause slippage and movement. One way to prevent this condition is to torch off, prior to application of the base sheet roll, the polyethylene film from the adjacent base sheet where the bleed-out may occur or, alternatively, eliminate the bleed-out.

Another cause of this type of wrinkle is a hollow or a void that is formed between the undersides of the cap sheet at the base sheet side lap locations. This is usually the result of an insufficient weld of the cap sheet to the base sheet in these areas.

### **BLISTERS**

Blisters are raised areas in the roof membrane containing an air or vapour pocket. Although these can occur between the base sheet and the substrate, blisters between the base sheet and cap sheet are most common. These are caused by air, gas or moisture trapped between the two surfaces during application. If the base sheet is not dry and clean when the cap sheet is applied, blisters may occur between them.

*Note:* Water, when heated to 100 degrees Celsius (100° C or 212° F) and at constant pressure (1 atmosphere) can expand to 1500 times its original volume.



Also pointing the torch directly under the sheet during application will push hot air under the roll and this air may become trapped, forming a blister.

To reduce the possibilities of blisters occurring, ensure that the substrate surface is dry prior to the base sheet application and ensure the base sheet surface is dry prior to the cap sheet application.

The cap sheet should be applied as soon as possible after the base sheet. The material manufacturer should be contacted regarding appropriate time intervals and preventive measures should this not be feasible.



If blisters appear under a lap, regardless of their size, they should be inspected for water tightness and should be cut out and repaired if the seal at the seam is inadequate. Blisters in the field of the sheet should remain untouched unless they appear to be growing, over time, in which case they should be cut, dried out and patched, as should blisters that may, because of their location, have adverse affects on the attachment of the assembly.

## **RIDGES**

Ridges appear as long raised areas extending beyond the dimensions of a single membrane sheet. They usually occur under the base sheet. Rarely are ridges a result of poor membrane application. They are usually associated with substrate (insulation or deck) movement. Simply cutting and repairing these will not solve the situation, as they normally will reoccur. These phenomena are not usually a waterproofing problem, but, once they affect a lap in a cap sheet or become sharp enough to affect the granule cover, they should be corrected. After an investigation to determine and repair the underlying cause, the roof membrane itself can be repaired.



## **SUMMARY**

Modified bitumen roof membranes can be successfully installed by employing a few basic installation practices.

As a general rule, it is much easier to mop thinner sheets and to torch thicker ones. Lightly torching base sheets as they are being mopped into hot asphalt will relax the rolls and help ensure that the asphalt temperature is adequate. Base sheet stripping should be torch applied on vertical surfaces to prevent slippage.

A fluid, even torching technique, that does not apply too much heat, will help prevent distortion of the polyester reinforcing. Extra care should be taken while applying the last two metres (2 m or 6') of a roll. At this point there is very little weight left in the roll to press the membrane down to secure a bond and especially if the membrane is wound very tightly it may not easily lay flat. Heavy polyester reinforced sheets may be stiff in cold weather. They will tend to keep their rolled shape unless properly conditioned prior to, or during application.

There are differences from one product to another. Experience working with each manufacturer's products will allow the necessary modifications to be made during application to suit each material. Ensure that the manufacturer's instructions are read and followed with each product used.

Although the information in these recommendations should reduce the number of wrinkles and ridges that appear in modified bitumen roof membranes, an owner should not necessarily be alarmed if these abnormalities occur on his/her roofs. As this review states, however, most cosmetic wrinkles and ridges are best left alone to ensure the continued performance of the membrane system.

---

---

## **Disclaimer**

While every attempt has been made to ensure completeness and accuracy has been made, this guide should be used as a reference only. The authors of this guide accept no responsibility for any errors or omissions with respect to the subject matter contained herein and expressly disclaim any such responsibility. This guide is not intended to provide legal advice; if legal or other expert assistance is required, the services of the appropriate professional should be sought.