



C182T Profiles Guide

Feb 2018, rev 1



The contents of this guide are unofficial non-mandatory guidance which do not replace procedures from official sources such as the airplane's POH and other Cessna, Garmin, and FAA sources. Use only as advisory for training purposes.

TABLE OF CONTENTS

CESSNA 182T TAKE-OFF	3
CESSNA 182T ABORTED TAKE-OFF	4
CESSNA 182T LANDING	5
CESSNA 182T GO-AROUND	6
MANEUVERING FLIGHT CHECKLIST	7
CESSNA 182T 45 DEGREE STEEP TURN	8
CESSNA 182T SLOW FLIGHT	9
CESSNA 182T POWER OFF (LANDING) STALL	10
CESSNA 182T POWER-ON (DEPARTURE) STALL	11
CESSNA 182T PRECISION INSTRUMENT APPROACH	12
CESSNA 182T NON-PRECISION INSTRUMENT APPROACH	13
CESSNA 182T MISSED APPROACH	14
C182T G1000/GFC-700 TAKE-OFF AUTOMATON	15
C182T G1000/GFC-700 CLIMB / DESCEND / LEVEL-OFF AUTOMATON	16
LOCAL GROUP 2 AIRPORT PROCEDURES	17

Cessna 182T Take-off

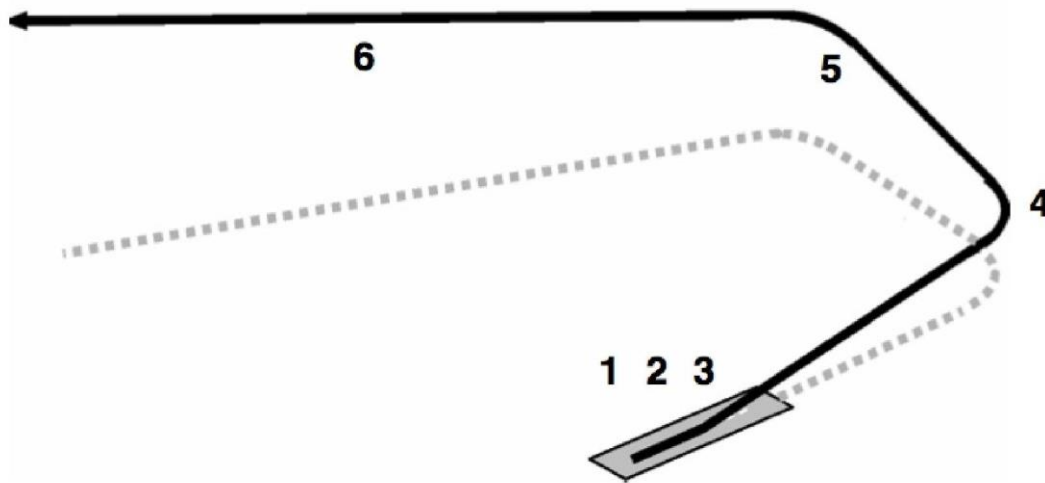

1. Cleared into Position

- Crew Departure Brief - COMPLETE
- Final Traffic – CLEAR
- Pre-takeoff checklist previously complete

2. Takeoff

- Perform normal takeoff checklist
- Engine Instruments - CHECK
- Airspeed – ACCELERATING
- Rotation pitch is approximately 7.5 degrees up (12-15 for short field takeoff until clearing the obstacle)
- Short field takeoff: Rotate approximately at 53 knots
- Ensure positive climb rate and clear of obstacles before retracting flaps

3. Cross Wind Departure

- Turn Above 700 AGL or as necessary

4. Climb

- Complete appropriate climb checklist (normal or maximum performance)

6. Downwind Departure

- Continue to Climb to Cruise Altitude

At uncontrolled airports, state intentions on CTAF when departing and before making any turns.

If departing against or across traffic flow, wait until at least pattern altitude + 500 before turning on course

Soft field takeoffs

Hold elevator aft using rolling takeoff technique on the runway. When rotating, level airplane just above runway. Be mindful of how much rudder is required to keep the nose aligned with the runway.

CAUTION: A tail strike can occur if elevator backpressure is not reduced as power is increased during the take-off roll.

Cessna 182T Aborted Take-off

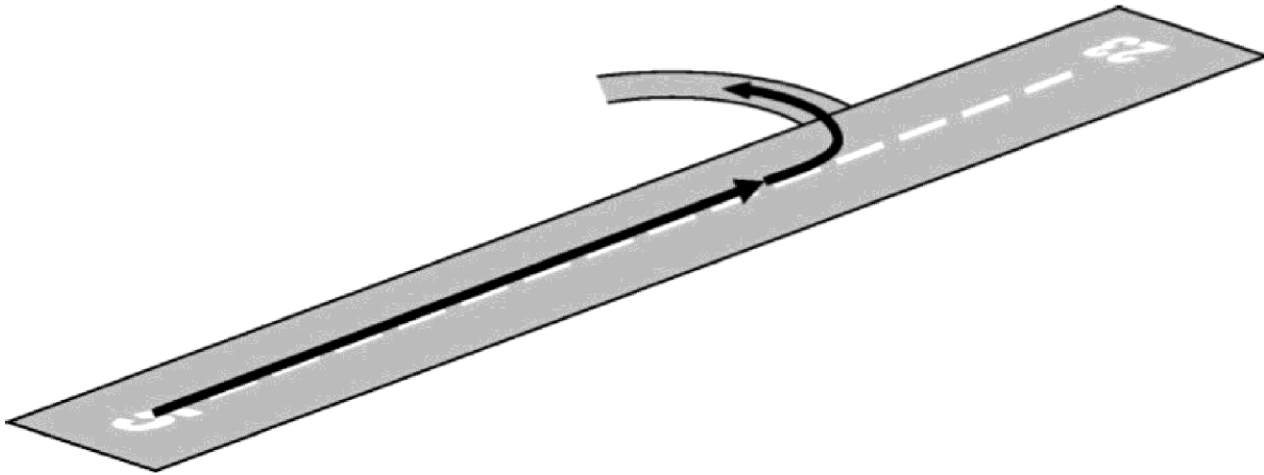

1. Decision to Abort/Reject Take-off

- a. Pilot noting the Anomaly Requiring Abort – **Announce ABORT, ABORT, ABORT**
- b. Throttle – IDLE
- c. Brakes –AS REQUIRED
- d. ATC/Local Traffic - NOTIFY

3. Clearing Runway

- a. Emergency Evacuation Checklist – COMPLETE AS APPROPRIATE

4. Evacuation NOT Required

- a. Appropriate Emergency Checklist - COMPLETE

Cessna 182T Landing

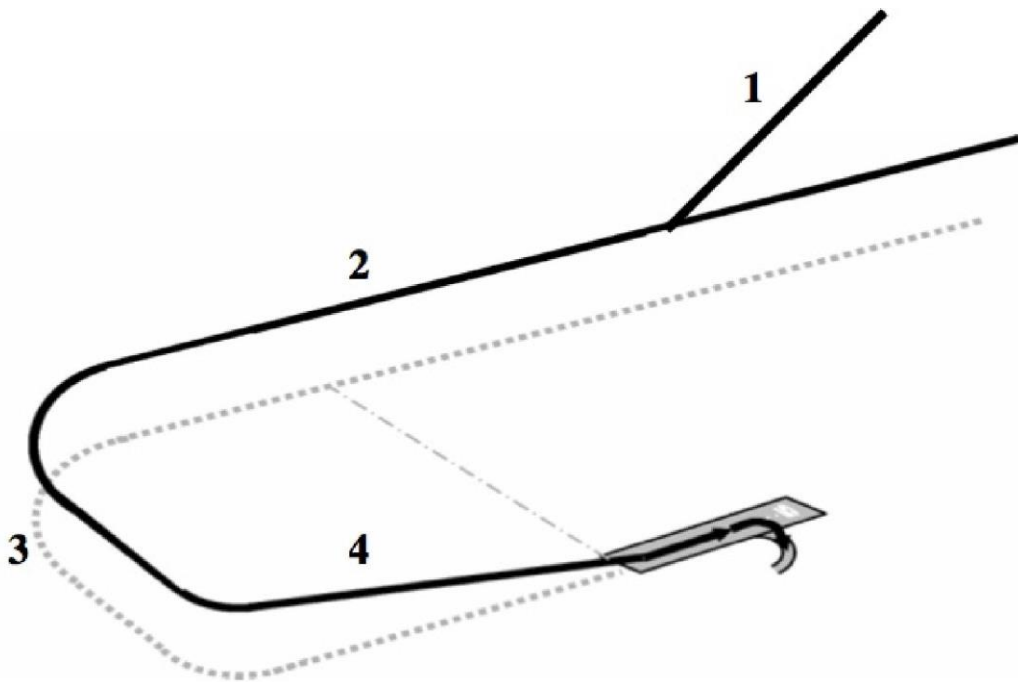

1. 45 Degree Entry

- Descend to traffic pattern altitude at well before pattern entry
- Airspeed slowing to 90 KIAS
- Pre-landing checklist - COMPLETE

2. Downwind

- Airspeed 90 KIAS (16-18" MP)
- Abeam landing point
 - Reduce Power (12-15" MP)
 - Pitch - Lower Nose
 - Flaps - 10 Degrees

3. Base

- Airspeed - 80 KIAS (12-15" MP)
- Flaps - 20 Degrees

4. Final

- Execute normal or short field checklist
- 12-15" MP will result in approximately 65-70 knots on final approach with flaps. Approximately 10-12 for 60 knots. MPs depend on weight and density altitude
- Soft field: full flaps and maintain 10-12" MP until after landing
- TRIM for airspeed

5. Touch Down

- Elevator Control - Slowly release back pressure. Hold aft if soft field landing to keep pressure off nose landing gear
Soft field: Maintain power through landing if required. Avoid stopping on wet or soft surfaces. Keep rolling until on firm terrain.
- After landing checklist complete once clear of runway and stopped.

NOTE: Gusty and/or strong crosswinds may require partial flaps and increase airspeed by $\frac{1}{2}$ the gust factor. Care must be taken not to flat spot tires.

Cessna 182Ts do not have a recommendation against forward slips with flaps extended. Still, be attentive on both airspeed and attitude while in a slip and gently roll out for passenger comfort. Also, remember to use aerodynamic braking on the runway.

Cessna 182T Go-Around

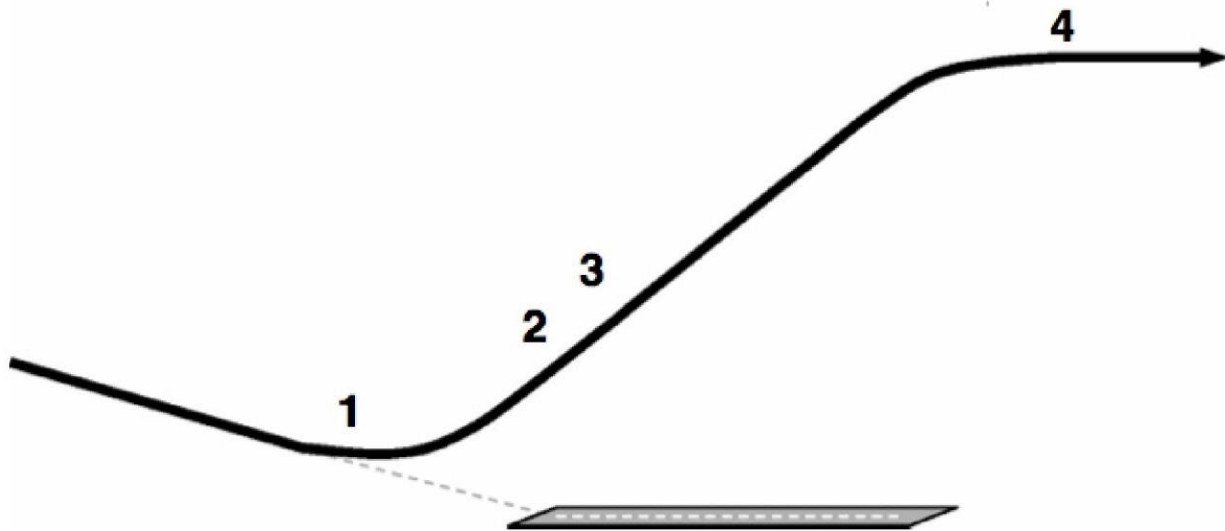

1. Go-Around Decision

- a. Perform BALKED LANDING checklist
- b. GA BUTTON – Depress
- c. PITCH – To FD Bars (GFC700)

2. Positive Rate

- a. FLAPS – Retract slowly in 10-degree increments > 70 KIAS
- b. Maintain Runway heading

3. Climb

- a. Perform appropriate climb checklist (normal or maximum performance)

4. Continue in traffic pattern or exit area

Cessna Maneuvering Flight Checklist

Maneuvering flight is best performed with more than one pilot, where one pilot performs maneuvers and the other monitors the flight and environment (terrain, traffic, etc.). The checklist below should be performed before practicing maneuvers.

- Airspace - Use uncongested airspace
- Emergency - Nearby emergency landing field
- Altitude – Above 1500' AGL except for ground reference maneuvers
- Seatbelts - SECURE
- Fuel Sector – BOTH
- Propeller – High RPM
- Engine Instruments – GREEN
- Wind Direction – CHECK
- Clearing Turns – ACCOMPLISHED for **EACH** maneuver
- Multi-Function Display – TRAFFIC AND TERRAIN ENABLE
- Airspeed – SLOW TO NO MORE THAN MANEUVERING (V_a)

Cessna 182T 45 Degree Steep Turn

Notes

Avoid sudden head movements.
 Maintaining constant bank angle will reduce attitude changes
 Do not “chase the VSI”.
 Make small corrections.
 Steep turns are a visual maneuver. Look outside for traffic and to prevent unintended pitch ups and downs.
 Establish 45 degrees and notice where the horizon intersects the cowl. Keep the horizon at that spot to stay at 45 degrees.

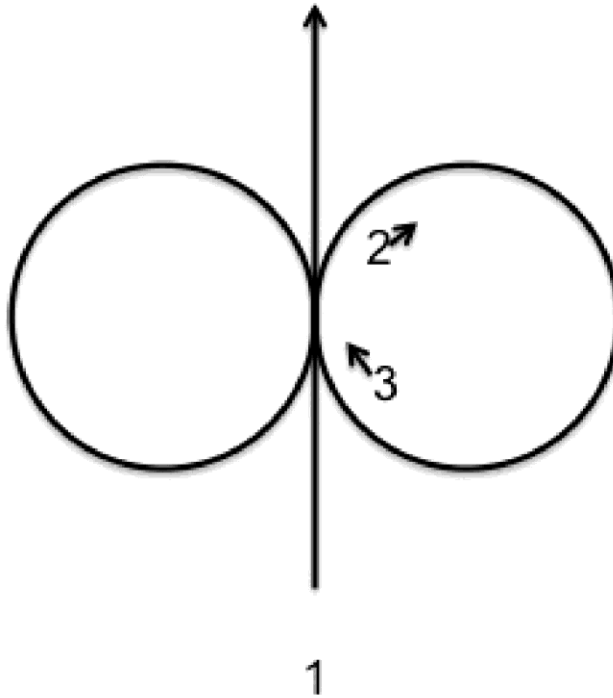

PERFORM CLEARING TURNS BEFORE ALL MANEUVERS

1. Entry Settings

- a. Power -17-19"
- b. Speed - Below V_a for current weight (101 KIAS at 2600 pounds)
- c. Heading Bug – Push to sync for entry Heading (push HEADING knob) or (preferably) pick a prominent landmark

2. Enter Turn

- a. Smoothly bank to 45 degrees (50 for commercial or ATP). Maintain coordinated flight.
- b. Pitch – 3-4 degrees nose up (typical) upon passing 30 deg bank
- c. Power - Add 1-2" MP to hold speed

3. Exit Turn

- a. Smoothly reduce bank to 0 degrees – Start 20 degrees before entry heading

4. Repeat

- a. Repeat in opposite direction

5. Recovery

- a. Complete the CRUISE checklist

Cessna 182T Slow Flight

PERFORM CLEARING TURNS BEFORE ALL MANEUVERS

Please monitor CHT throughout and open cowl flaps as needed

1. Entry Settings

- a. Engine Instruments – Select System -> Lean. CHT must remain < 400 degrees
- c. Heading Bug – SNAP to entry Heading (push HEADING knob) or (preferably) pick a prominent landmark

2. Clean Configuration

- a. Flaps – 0 Degrees
- b. Power – 12” MP
- c. Pitch – maintain level flight
- d. Speed – Any decrease would result in stall warning
- e. Power – Increase power to maintain altitude and airspeed just above stall warning
- f. Turns – No more than 15 degrees bank. Add power as needed

3. Full Flaps Configuration

- a. Flaps – 40 degrees
- b. Power – As needed to maintain altitude
- c. Pitch – maintain level flight
- d. Speed – Any increase would result in stall warning
- e. Power – Increase power to maintain altitude and airspeed just above stall warning. Turns – No more than 15 degrees bank. Add power as needed

4. Recovery

- a. Power – 23” to get back to cruise speed
- b. Pitch – Lower nose to horizon to increase speed
- c. Complete CRUISE checklist

Cessna 182T Power Off (Landing) Stall

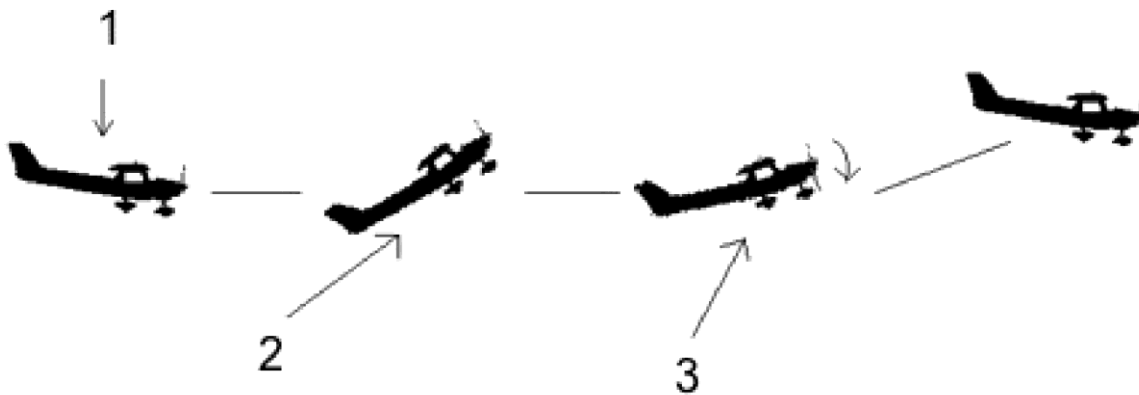

**PERFORM CLEARING TURNS BEFORE ALL MANEUVERS.
USE RUDDER TO MAINTAIN COORDINATED FLIGHT THROUGHOUT
THIS MANEUVER**

1. Entry Settings

- Engine Instruments – Select System -> Lean. CHT must remain < 400 degrees
- Power – 12" MP
- Flaps – To full staying under flap speeds for each increment
- Complete BEFORE LANDING checklist
- Heading Bug – SNAP to entry Heading (push HEADING knob) or (preferably) pick a prominent landmark
- Speed – Reduce to final approach speed

2. Induce Stall

- Pitch – lower nose to attain a 500 FPM descent and stabilize descent
- Power – Reduce to IDLE
- Pitch – Maintain 500 FPM descent until imminent (horn) or full stall

3. Recovery

- Simultaneously
 - Pitch – Reduce angle of attack by releasing only as much back elevator pressure as necessary to minimize altitude loss
 - Power – Advance to maximum allowable power
- Flaps – 20 Degrees
- Flaps - Slowly retract as airspeed increases (> 70 KIAS) and open cowl flaps
- Complete CRUISE checklist

Cessna 182T Power-On (Departure) Stall

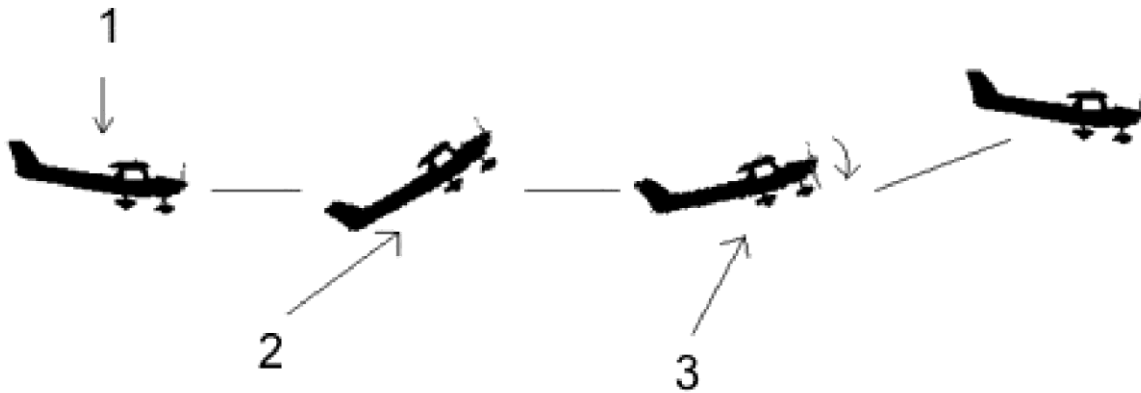

**PERFORM CLEARING TURNS BEFORE ALL MANEUVERS.
USE RUDDER TO MAINTAIN COORDINATED FLIGHT THROUGHOUT
THIS MANEUVER**

1. Entry Settings

- Engine Instruments – Select System -> Lean. CHT must remain < 400 degrees
- Power – 12" MP
- Flaps – 0 degrees
- Pitch – Maintain level flight
- Heading Bug – SNAP to entry heading (push HEADING knob) or (preferably) pick a prominent landmark
- Speed – 60 KIAS
- Cowl Flaps – Open
- Mixture – Rich
- Propeller – Full forward

2. Induce Stall

- Power – 20-22" MP (at least 65% of available power)
- Pitch – Increase as necessary until imminent (horn) or full stall
- Bank – 0-20 degrees

3. Recovery

- Simultaneously
 - Pitch – Reduce angle of attack by releasing back elevator pressure only as required to break the stall, in order to minimize altitude loss
 - Power – Advance to maximum allowable power
 - Flaps – Slowly retract as airspeed increases
- Complete CRUISE checklist

Cessna 182T Precision Instrument Approach

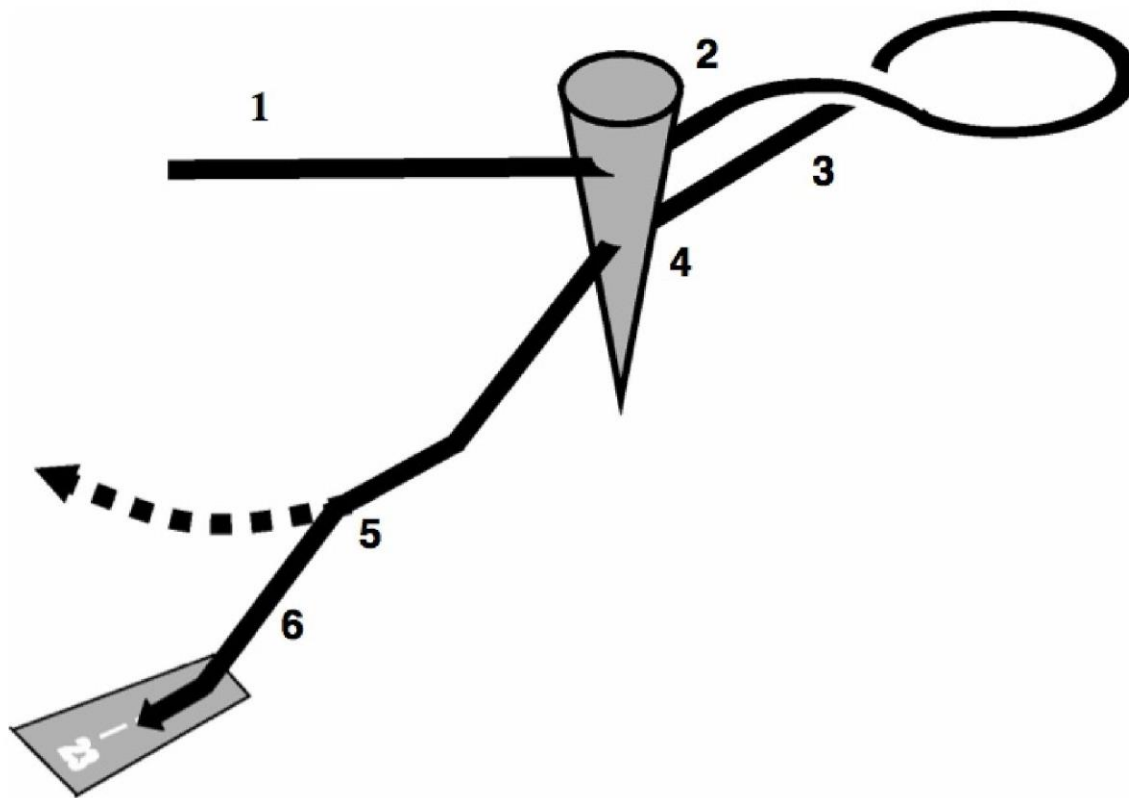

1. Outside IAF or- Downwind (Vectors)

- ATIS
- Procedure loaded in G1000
Activate when cleared
- Descent Checklist complete
- Approach Brief - COMPLETE

2. IAF or- Base Leg (Vectors)

- Flaps - 0-20 degrees (10 typical)
- Airspeed 90 KIAS (16-18" MP)

3. 2-3 NM before FAF

- Verify configuration & Speed
- Verify CDI NAV Mode is correct for the approach
- FLAPS - 0 to 20 degrees (10 typical)
- Landing checklist complete
- Altitude bug to missed approach altitude

4. Glide-slope/path Intercept

- Initiate Descent - 90 KIAS (12-15" MP)
- TIMER - Start (or FAF if appropriate) as applicable
- Verify Glide Slope Intercept Altitude
- Verify FAF altitude intercept

5. Decision Height

- Elect LAND -OR- MISSED
- IF LANDING - Flaps and/or Power as needed to slow to normal landing speed
- IF MISSED - Press GA, pitch up, add power, retract flaps....

Remember the acronym ALBAA to remind you of tasks to accomplish for each approach:

A: ATIS **L:** Load **B:** Brief (including missed) **A:** Activate **A:** Arm (if following GS or GP)

Cessna 182T Non-Precision Instrument Approach

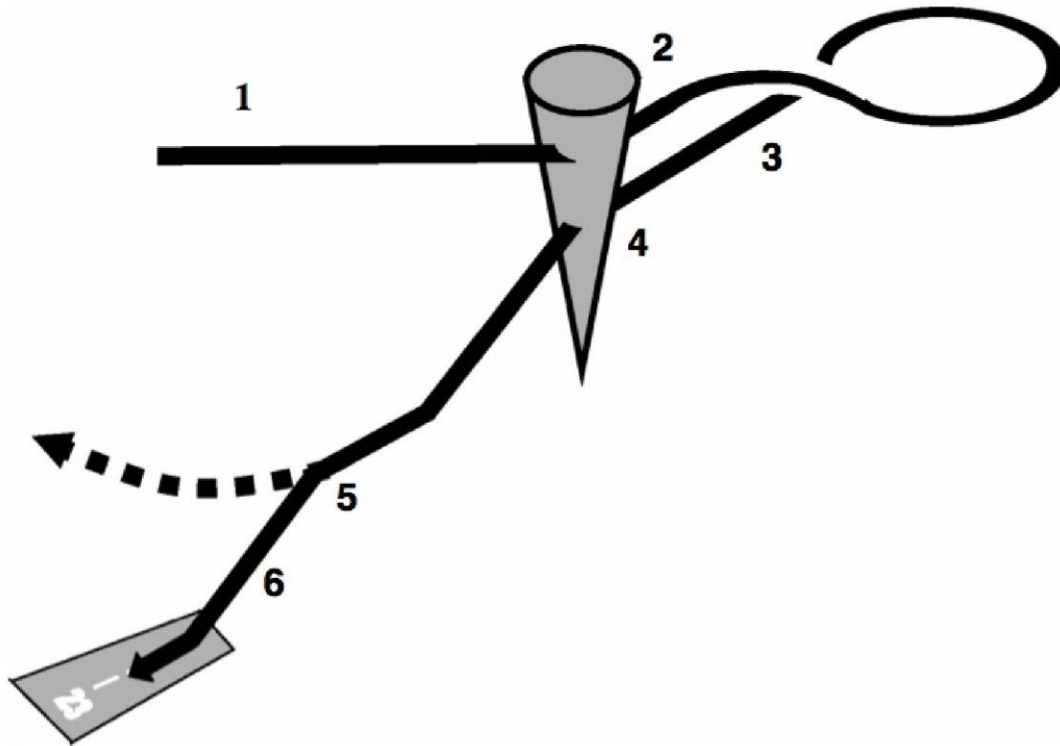

1. Outside IAF or- Downwind (Vectors)

- ATIS
- Procedure loaded in G1000. Activate when cleared
- Approach Checklist complete
- Approach Brief - COMPLETE

2. IAF or- Base Leg (Vectors)

FLAPS – 0-20 degrees (10 typical). Airspeed 90 KIAS (16-18" MP)

3. 2-3 NM before FAF

- Verify configuration & Speed
- Verify CDI NAV mode
- FLAPS – 0 to 20 degrees (10 typical)
- Landing checklist complete
- Altitude bug to missed approach altitude
- Approach armed

4. Final Approach Fix

- Initiate Descent – 90 KIAS (12-15" MP)
- TIMER – Start as necessary

5. MDA

- Elect LAND –OR- MISSED
- IF LANDING – Flaps and/or Power as needed to maneuver and slow to normal landing speed
- IF MISSED – Press GA, pitch up, add power, retract flaps....

Remember the acronym ALBAA to remind you of tasks to accomplish for each approach:

A: ATIS **L:** Load **B:** Brief (including missed) **A:** Activate **A:** Arm (if following GS or GP)

Cessna 182T Missed Approach

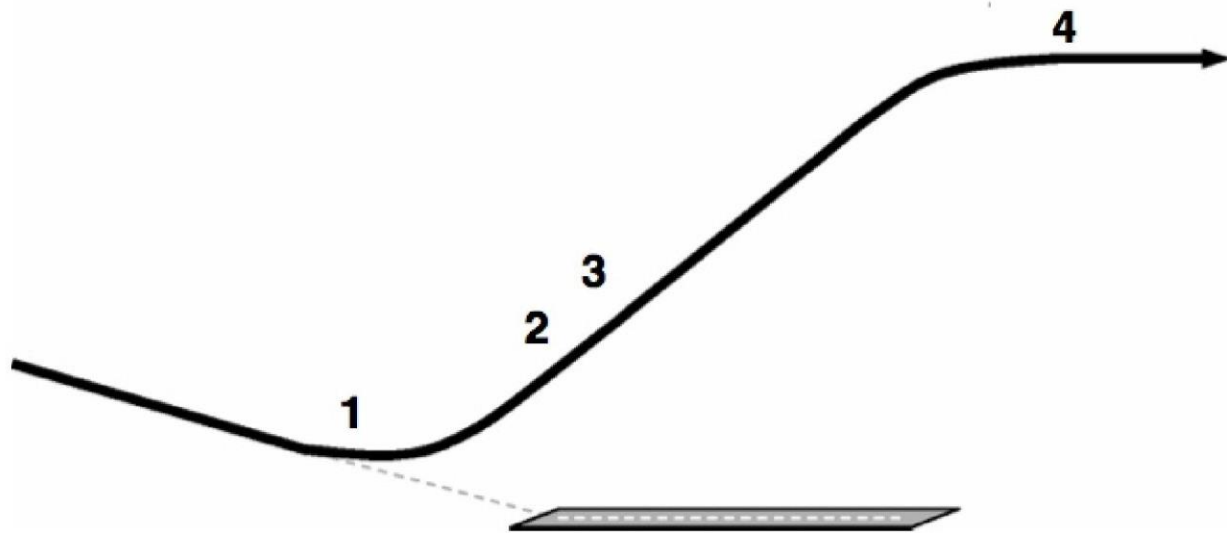

1. Missed Approach Decision

- a. THROTTLE – Set Full
- b. GA BUTTON – Depress (GFC700 Only)
- c. PITCH – To FD Bars (GFC700)–or- 7-8 degrees up (KAP140) (MAINTAIN V_x)
- d. FLAPS – Retract to 20 if FULL (go around checklist)
- e. COWL FLAPS - Open

2. Positive Rate & Over 70 KIAS

- a. FLAPS – Retract slowly – 10 degrees at a time
Over 1,000' and if climb rate suffices
- b. Complete climb checklist

3. Flight Director (GFC 700)(KAP 140)

- a. HDG and ALT BUGS – Per Missed Approach
- b. SUSP Soft key – Per Missed Approach Procedure
- c. CDI SOFTKEY – Verify NAV source
- d. NAV BUTTON – Depress

4. Report

- a. Report Missed Approach to ATC

CAUTIONARY NOTE:

Follow Missed Approach Procedures
EXACTLY as published, i.e. climb
before
turning (READ CAREFULLY!!!)

C182T G1000/GFC-700 Take-Off Automation

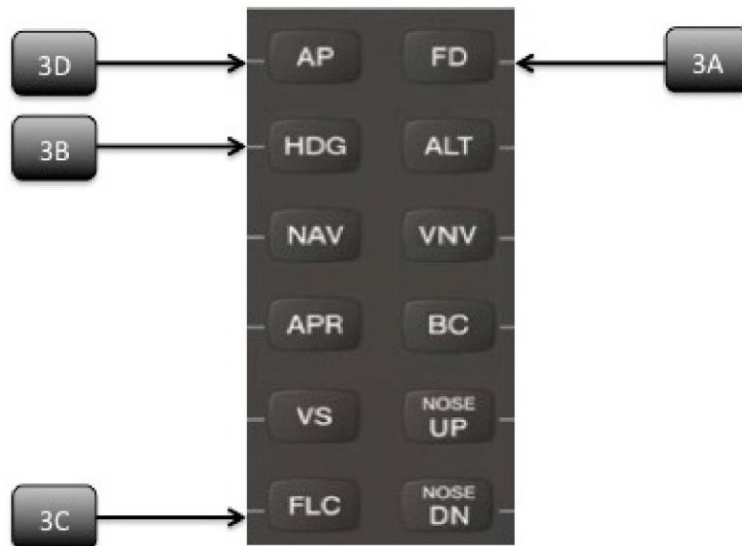

1. Pre-takeoff

- a. PFD ALT KNOB – Verify desired altitude set above Altitude Tape
- b. PFD HEADING BUG – Set runway heading

2. Establish Normal Climb

- a. See Take-Off Procedures
- b. Wait until at or above 1000' AGL

3. Engage Autopilot

- a. FD (Flight Director) – ON (Verify on PFD)
- b. HDG – Set heading of desired track
- c. FLC – Set 90 KIAS (or 85-95 depending on needs)
- d. AP - Autopilot engage Verify status on PFD (HDG, FLC to ALTS)
- e. Callout – “AUTOPILOT ENGAGED”

4. Intercept Course

- a. PFD CDI Source – Select GPS or VOR. Set VOR course
- b. PFD Heading Bug – Turn to an intercept course. Validate heading converging on course
- c. NAV - Lateral Mode – Set lateral mode to intercept CDI (Verify status HDG to GPS or VOR)

C182T G1000/GFC-700 Climb / Descend / Level-off Automation

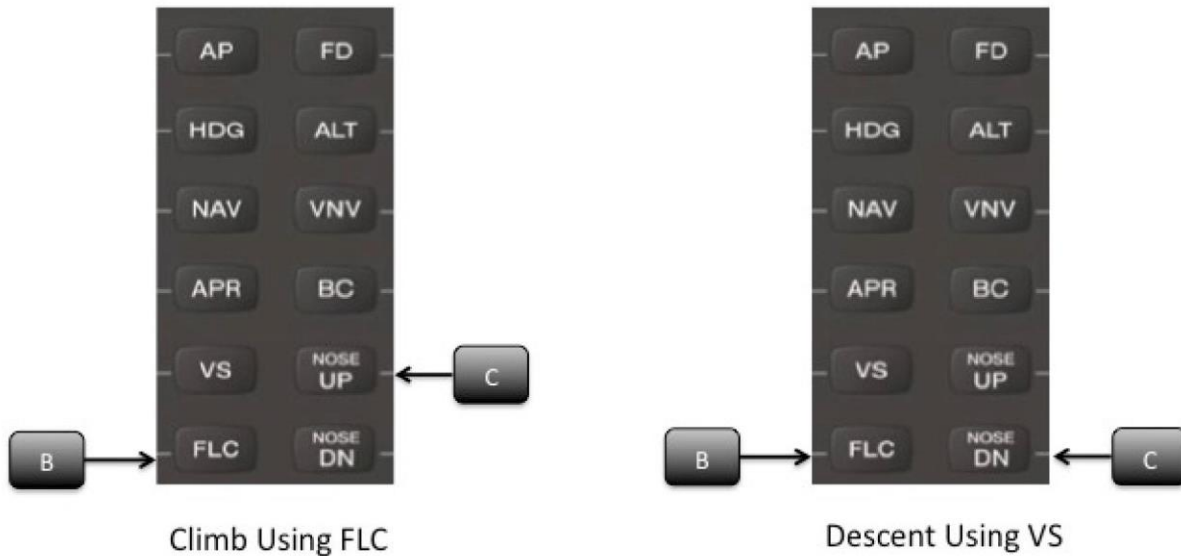

Climb to a selected altitude (autopilot engaged)

- PFD ALT KNOB - Set altitude in window above altitude tape
- FLC BUTTON - Set constant airspeed climb
- NOSE UP BUTTON - Set desired airspeed on airspeed tape (85-95 KIAS)
- Perform climb checklist

Descend to a selected altitude (autopilot engaged)

- PFD ALT KNOB - Set altitude in window above altitude tape
- VS BUTTON - Select constant rate descent
- NOSE DOWN - Select rate of descent on autopilot status bar ~500 FPM (manage pax comfort)
- Perform descent checklist

Arriving at selected altitude

- 1000' TO GO - Pilot callout
- 200' TO GO - Pilot Callout
- Monitor autopilot for level out
- CRUISE CHECKLIST - COMPLETE

Local Group 2 Airport Procedures

This section describes some local procedures at group 2 airports that host a CAP airplane. As always, directives from local authorities and the FAA (such as the chart supplement) take precedence. Please make sure you check airplane squawks before flying. This document does not comment on the operational capability or maintenance state of our airplanes.

CONCORD (CCR) (948CP or CAP 448)

The hangar is in Northwest corner of airport and is accessed through gate at the end of Sally Ride Drive.

Need an access card to get in gate. If card needed, get Affiliate application from airport website. Tim Albert (or current Squadron 44 Commander) needs to sign (wet signatures required). Form needs to be taken to airport office during normal business hours to get a card. There is a deposit for the card (call airport operations for

In an emergency where no card is available, contact airport operations at 925-383-0005.

Opening hangar:

- Open side doors first
- Do NOT hang padlock where door halves come together
- After side doors are LOCKED open, open center door slowly but fully
- **BE SURE SIDE DOORS ARE LOCKED OPEN AND CENTER DOOR IS ALL THE WAY UP BEFORE MOVING AIRCRAFT IN OR OUT OF HANGAR**

Generator can be used for night ops and/or GPU use. It is kept with the fuel turned off. To start, turn on key, turn fuel on, set choke, pull handle to start. Once running, turn off choke. Plug extension cord into 110 outlet on generator, other end into outlet in hangar.

To shut generator off, turn key off, turn fuel off, unplug and coil extension cord, placing on top of generator.

GPU is on back shelf under plastic. To use, plug into generator after it is running, set to 28 Volts, plug into aircraft external power jack (ensure all electrical is off), validate set to 28 Volts again, turn on. To shut off, turn all ship electrical off, turn GPU off, unplug from aircraft, unplug from generator, return to shelf and place plastic over it.

Closing hangar:

- Ensure aircraft is COMPLETELY inside hangar
- Close center door SLOWLY
- Validate both doortop locks are secure
- Close desk side door – ensure both top and bottom posts are locked
- Close generator side door and lock – ensure digits on lock are upright

SECURING AIRCRAFT:

- Keys should be kept in lockbox hanging from pilot side wing tie down loop.
- Cowl plugs should be in when aircraft is in hangar – ENSURE rope is in FRONT of propeller blade.
- Pitot tube cover should be on when aircraft is in hangar.
- Cowl flaps should be CLOSED when in hangar.
- Fuel Selector should be on Left or Right when in hangar.
- Throttle lock should be installed while in hangar.
- All three aircraft doors should be locked while in hangar.
- AIF should be placed on the pilot's seat while in hangar.
- Tow bar (blue one) should rest against desk.

Be aware of HOT SPOTS! If needed, get a progressive taxi. You are at the CIVIL AIR PATROL hangar (next to Discovery air).

Read back all crossing and hold short instructions.

If in 32L runup, validate you do NOT inadvertently enter 19R when taxiing out to runway (it's on your left).

Noise abatement takeoff runways 32, no turns before crossing railroad tracks.

Cheapest fuel is Sterling – 925-676-2100. Alternately you can use PSA – 925-685-4400. Fuel closes at 1800 Local (Winter) or 2000 Local (Summer). There is NO SELF-SERVICE fuel on the field. Plan ahead and if landing after Sterling / PSA are closed, you need an additional sortie and go to O88, C83, or LVK to fuel prior to returning to CCR.

LIVERMORE (LVK) (N6183E or CAP 483)

<p>LIVERMORE MUNICIPAL AIRPORT (KLVK) PILOT INFORMATION GUIDE www.cityoflivermore.net/airport</p>	
<p>LOCATION N 37° 41' 36.20" W 121° 49' 13.30" N 37° 41' 60.3333" W 121° 49' 22.1667" N 37.6933889° W 121.8203611° Elevation : 400 ft MSL / 121.9 m (surveyed) Variation : 13.7° E (1/2015) 3 miles West of Livermore, CA (zip = 94551)</p>	<p>AIRPORT OPERATIONS Airport Use : Open to the public Sectional Chart : SAN FRANCISCO Control Tower : YES (0700-2100 PST/PDT daily) ARTCC : OAKLAND CENTER FSS : OAKLAND FSS (1-866-469-7828) NOTAM's Facility : LVK NOTAM-D Service Available FBO Hours : 0600-1800 (925-315-4130) Pattern Altitude: 1400 ft MSL Wind Indicator: Midfield, Lighted Segmented Circle: YES Lights 07L/25R : Lighted, PCL on CTAF (3x, 5x, 7x) 07R/25L : NONE Taxiways : Lighted, PCL on CTAF Beacon: White-Green (lighted land airport)</p>
<p>COMMUNICATIONS ATIS 119.65 TOWER 118.1 GROUND 128.2 ASOS 121.6 CTAF 119.65 ILS/LOC 118.1 UNICOM 110.5 NDB (REIGA) 374 NORCAL APPROACH : 123.850 RWY 07R/07L/25R/25L NORCAL DEPARTURE: 125.350 RWY 25R/25L 125.850 RWY 07R/07L</p>	<p>COMMUNICATIONS 925-447-9516 925-443-0666, 0700-2100 LCL (when necessary) 925-443-0666, 0700-2100 LCL (when tower closed) 925-606-5412 (monitored by FBO)</p>

Copyright © 2016, Courtesy Brett M Wayne

FOR REFERENCE ONLY!
 ALWAYS COMPLY WITH ATC INSTRUCTIONS!
 SAFETY IS ALWAYS PARAMOUNT!

HELP US TO REDUCE NOISE!
 Adhere to Voluntary Restraint from Night Flying Policy (10 PM - 6 AM local)
ARRIVALS
 ♦ Remain at traffic pattern altitude (1400' MSL) as long as practical before descending to land.
DEPARTURES
 ♦ Climb as quickly as practical to pattern altitude.
 ♦ Avoid intersection takeoffs

RECOMMENDED VFR PROCEDURES
 ♦ Use preferred arrival and departure corridors
 ♦ Keep you patterns tight
 ♦ Avoid overflying residential areas
 ♦ Avoid straight-in VFR arrivals
 ♦ Avoid low passes and formation arrivals
 ♦ Avoid abrupt maneuvering, power, and sudden propeller RPM changes
 ♦ Watch those propeller helical tip speeds!

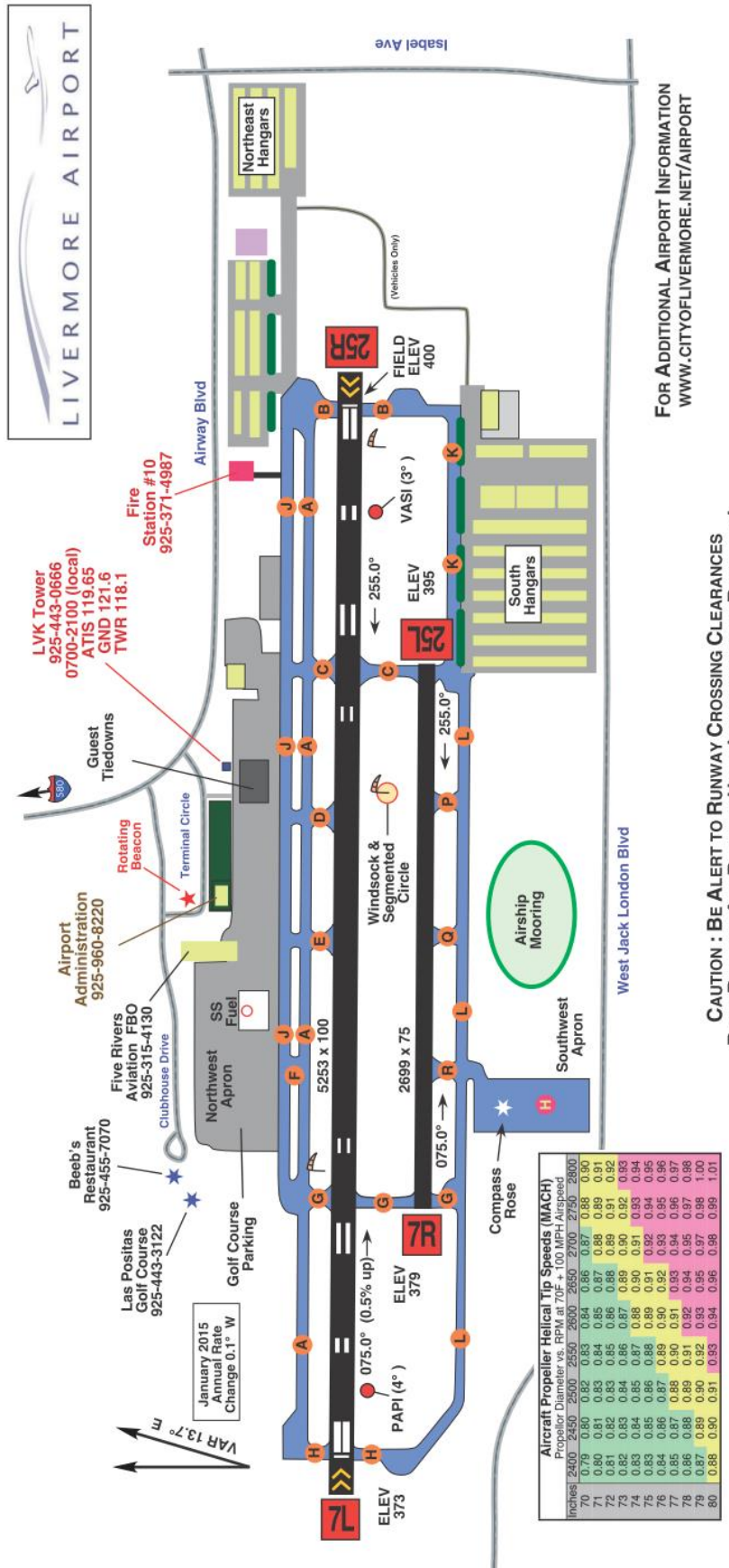

N6183E is hosted at LVK at the base of the tower. Gaining access requires walking through the unsecured man gate in front of the old Terminal Building or walking through the secured gate in front of the new terminal. The vehicle gate code is available through the aircraft manager (name and contact info available through WMIRS).

LVK has a training tower and sometimes when traffic increases a south tower frequency of 128.2 to control runway 25L and approaches from the south. Livermore north tower remains on 118.1 for 25R and approaches from the north. There is both a self-serve fuel pump and a fuel truck by five rivers aviation.

Please familiarize yourself with the Livermore airport information above. Subject to change. The most up to date version can be found at:
<http://www.cityoflivermore.net/civica/filebank/blobdload.asp?BlobID=14348>

OAKLAND (OAK) (N183CP or CAP 481)

N183CP (CAP 481) is hosted at OAK's north field between hangars 7 and 8 (coordinates: 37.734342 N, 122.216223 W). Gaining access to the airplane requires a TSA airport badge and a hangar key, both of which require a lengthy process that must be coordinated with the local squadron (188). Kaiser air is preferred but signature also serves us. Note that the fuel truck does not issue receipts or take credit cards. You'll have to either call in and give them your credit card over the phone and an email to send the receipt to or drop by their offices. If you are flying a CAP plane other than CAP481 be sure to ask for the CAP discount.

Note that OAK includes several taxiway hotspots and a "zipper" lane for vehicles to use. Also, large airline jets, and more frequently other smaller jets, use the north (GA) field so be careful of jet blasts and appropriate distances from other airplanes.

Noise abatement procedures are included in the chart supplement. Most frequently, when taking off from 28R you should make your crosswind turn after passing abeam runway 33 numbers and before the airport fence. If you are landing late at night tower may offer runway 30 at the south field. OAK does allow airplanes to stay in the pattern though when busy tower may have you extend your downwind frequently. When in the pattern for 28L, you need to stay to the east of the tower (between the tower and runway 28L). This requires an unusually tight traffic pattern with not enough space for a crosswind leg. You may have to keep your turn close, but not over, to 30 degrees bank.

The preferred runway is 28R or 28L if tower offers it. Runway 33 is also an option but is shorter, narrower, and has no good options for a straight-ahead landing in the event of a low-altitude engine loss during takeoff. None of these runways have a painted run-up area. For runway 28R, this is typically accomplished abeam the runway 28R numbers, between those and the squadron

building. Be careful not to block the zipper lane and to give ample space from the adjacent taxiway for jet traffic. Runway 33 has no good options close to it. The best options are to perform the run-up next to a nearby blast fence shown in the third figure below. The airplane's tail should face the Blast Fence so that prop-wash is deflected upward and away from other aircraft and buildings. Should light traffic conditions prevail, run-ups may be conducted prior to the Runway 33 holding position marking on Taxiway C as shown in Figures 2, and 3. However, should lengthy mission related programming be anticipated, utilize the Blast Fence run-up area as shown in 3. Run-ups shall not be conducted at Hangar 7 as displayed in Figure 1. Run-ups shall not be conducted beside the port-a-ports or the trailers displayed in Figures 1, and 2. Run-ups shall not be conducted on taxiway Juliet. Be sure to stay inside taxiway double solid lines at all times:





PALO ALTO (PAO) (N445CP or CAP 445)

To reach the squadron building turn off Embarcadero at the golf course and take the airport boundary road toward the tower. Plane is tied down next to the squadron building and the key is on the tieddown, standard combination. There is a self-serve fuel pump and fuel truck by Rossi aviation.



Taxi: When ready to taxi contact ground and give them your location as row Hotel and your desired departure, typically left or right Dumbarton. Expect taxi instructions of "hotel zulu" and either a 180 in run-up or "turn right on mike into run-up".

Departures: The wind generally favors runway 31, in which case you would use a left or right Dumbarton departure: proceed on the departure leg until the Dumbarton auto bridge and then turn left or right. When runway 13 is active, use either a Leslie salt (hdg 020 and below 1500ft until reaching Leslie salt) or a left 270 overhead then continue westbound. Beware of San Francisco airspace (2500 ft), San Jose airspace (1500 ft) and Moffett field airspace.

Arrivals: From the East: Report over Leslie salt, then proceed to the East end of the train bridge and enter a 45 for right traffic for runway 31 or left base for runway 13. From the West: Report over SLAC and proceed on a 45 for runway 31 or right base for runway 13.

Reporting points: Dumbarton bridge (auto bridge), train bridge, Cooley landing, Amphitheater, bird house, Leslie salt, KGO, SLAC.

Pattern: TPA is 800ft for right/left traffic on runway 31/13 and 1000ft for left/right traffic on runway 31/13. For runway 31 turn base within 1nm of the airport (approximately abeam the landfill), but occasionally the tower will get an extension from Moffett and direct airplanes to turn base over the Amphitheater.

Noise abatement procedures: Airplane are asked to climb and maintain at least 1500ft before crossing Highway 101 and to fly over the bay whenever possible. When using runway 31 for right traffic, turn to heading 320 on the departure leg. See <http://www.countyairports.org/docs/PilotInsert-PAO.pdf>

Fuel. Both Chevron (122.85) and Exxon (122.95) offer fueling from their respective trucks from 7 AM to dark.

REID-HILLVIEW (RHV) (N7304N or CAP404)

CAP404 is located close to the squadron building on an outside tiedown close to the airport fence (spot H11). If you are driving in or using the pedestrian gate, it will be just ahead and to your left. CAP404 has the old paint CAP scheme so do not be confused. The lockbox to access the keys has the standard combination. There is a box next to the airplane with supplies. The throttle sometimes has a lock on. There is a lockbox at the squadron door (for the combo ask the aircraft manager as stated in WIMRS) with a card if you have to drive on the field, though there is usually no reason to do so because there is ample parking.

CAP404 is a Cessna 206U round-dial. It has an on-board IFR GPS but no working autopilot. This is an airplane that requires good training and proficiency because of operating limitations in the POH, such as for continuous power output, RPM, and the two operation settings of the electrical fuel pump. The fuel selector has no “both” option. The baggage door is also entirely different than Cessna 182s, and there is a switch to detect when the door is open which disables the flaps. There are four seats, not six. Cessna 206 training will cover all these aspects. Even if you are qualified in 206s, please make a proper self-assessment for your currency.

Be mindful of the RHV noise abatement procedure when departing 31R, spelled out in the chart supplement. When making a downwind departure from 31L, be careful not to enter SJC class C which is both ahead and to your left. Don't make your pattern wide. 31R and 31L are most often used due to winds. Survey the area and have a solid emergency plan because good landing spots are hard to find. “UTC” is a popular reporting position south of the airport and approximately 10 nm away. That area often has heavy traffic departing from or arriving to RHV. Another popular departure is “Calaveras” which requires making a right 45 degree turn when departing from 31R (or 31L if cleared to do so) towards the calaveras reservoir. That is another dense traffic area. Be careful when turning from base to final because sometimes there is traffic for the parallel runway doing the same, which will put it near you. Careful not to overshoot your turn. Because of the parallel runways, be especially mindful to read back runway assignments and watch for traffic when you taxi onto the runway.