

Holt Mathematics

Course 3 Homework and Practice Workbook



HOLT, RINEHART AND WINSTON

A Harcourt Education Company

Orlando • Austin • New York • San Diego • London

Copyright © by Holt, Rinehart and Winston

All rights reserved. No part of this publication may be reproduced or transmitted in any form or by any means, electronic or mechanical, including photocopy, recording, or any information storage and retrieval system, without permission in writing from the publisher.

Teachers using HOLT MATHEMATICS may photocopy complete pages in sufficient quantities for classroom use only and not for resale.

Printed in the United States of America

If you have received these materials as examination copies free of charge, Holt, Rinehart and Winston retains title to the materials and they may not be resold. Resale of examination copies is strictly prohibited and is illegal.

Possession of this publication in print format does not entitle users to convert this publication, or any portion of it, into electronic format.

ISBN 0-03-078464-6

1 2 3 4 5 170 09 08 07 06

CONTENTS

Chapter 1

Lesson 1-1	Variables and Expressions	1
Lesson 1-2	Algebraic Expressions	2
Lesson 1-3	Integers and Absolute Value	3
Lesson 1-4	Adding Integers	4
Lesson 1-5	Subtracting Integers	5
Lesson 1-6	Multiplying and Dividing Integers	6
Lesson 1-7	Solving Equations by Adding or Subtracting	7
Lesson 1-8	Solving Equations by Multiplying or Dividing	8
Lesson 1-9	Introduction to Inequalities	9

Chapter 2

Lesson 2-1	Rational Numbers	10
Lesson 2-2	Comparing and Ordering Rational Numbers	11
Lesson 2-3	Adding and Subtracting Rational Numbers	12
Lesson 2-4	Multiplying Rational Numbers	13
Lesson 2-5	Dividing Rational Numbers	14
Lesson 2-6	Adding and Subtracting with Unlike Denominators	15
Lesson 2-7	Solving Equations with Rational Numbers	16
Lesson 2-8	Solving Two-Step Equations	17

Chapter 3

Lesson 3-1	Ordered Pairs	18
Lesson 3-2	Graphing on a Coordinate Plane	19
Lesson 3-3	Interpreting Graphs and Table	20
Lesson 3-4	Functions	21
Lesson 3-5	Equations, Tables, and Graphs	22
Lesson 3-6	Arithmetic Sequences	23

Chapter 4

Lesson 4-1	Exponents	24
Lesson 4-2	Look for a Pattern in Integer Exponents	25
Lesson 4-3	Properties of Exponents	26
Lesson 4-4	Scientific Notation	27
Lesson 4-5	Squares and Square Roots	28
Lesson 4-6	Estimate Square Roots	29
Lesson 4-7	The Real Numbers	30
Lesson 4-8	The Pythagorean Theorem	31

CONTENTS, *CONTINUED*

Chapter 5

Lesson 5-1	Ratios and Proportions	32
Lesson 5-2	Ratios, Rates, and Unit Rates	33
Lesson 5-3	Dimensional Analysis	34
Lesson 5-4	Solving Proportions	35
Lesson 5-5	Similar Figures	36
Lesson 5-6	Dilations	37
Lesson 5-7	Indirect Measurement	38
Lesson 5-8	Scale Drawings and Scale Models	39

Chapter 6

Lesson 6-1	Relating Decimals, Fractions, and Percents	40
Lesson 6-2	Estimate with Percents	41
Lesson 6-3	Finding Percents	42
Lesson 6-4	Finding a Number When the Percent is Known	43
Lesson 6-5	Percent Increase and Decrease	44
Lesson 6-6	Applications of Percents	45
Lesson 6-7	Simple Interest	46

Chapter 7

Lesson 7-1	Points, Lines, Planes, and Angles	47
Lesson 7-2	Parallel and Perpendicular Lines	48
Lesson 7-3	Angles in Triangles	49
Lesson 7-4	Classifying Polygons	50
Lesson 7-5	Coordinate Geometry	51
Lesson 7-6	Congruence	52
Lesson 7-7	Transformations	53
Lesson 7-8	Symmetry	54
Lesson 7-9	Tessellations	55

Chapter 8

Lesson 8-1	Perimeter and Area of Rectangles and Parallelograms	56
Lesson 8-2	Perimeter and Area of Triangles and Trapezoids	57
Lesson 8-3	Circles	58
Lesson 8-4	Drawing Three-Dimensional Figures	59
Lesson 8-5	Volume of Prisms and Cylinders	60
Lesson 8-6	Volume of Pyramids and Cones	61
Lesson 8-7	Surface Area of Prisms and Cylinders	62
Lesson 8-8	Surface Area of Pyramids and Cones	63
Lesson 8-9	Spheres	64
Lesson 8-10	Scaling Three-Dimensional Figures	65

CONTENTS, *CONTINUED*

Chapter 9

Lesson 9-1	Samples and Surveys	66
Lesson 9-2	Organizing Data	67
Lesson 9-3	Measures of Central Tendency	68
Lesson 9-4	Variability	69
Lesson 9-5	Displaying Data	70
Lesson 9-6	Misleading Graphs and Statistics	71
Lesson 9-7	Scatter Plots	72
Lesson 9-8	Choosing the Best Representation of Data	73

Chapter 10

Lesson 10-1	Probability	74
Lesson 10-2	Experimental Probability	75
Lesson 10-3	Use a Simulation	76
Lesson 10-4	Theoretical Probability	77
Lesson 10-5	Independent and Dependent Events	78
Lesson 10-6	Making Decisions and Predictions	79
Lesson 10-7	Odds	80
Lesson 10-8	Counting Principles	81
Lesson 10-9	Permutations and Combinations	82

Chapter 11

Lesson 11-1	Simplifying Algebraic Expressions	83
Lesson 11-2	Solving Multi-Step Equations	84
Lesson 11-3	Solving Equations with Variables on Both Sides	85
Lesson 11-4	Solving Inequalities by Multiplying or Dividing	86
Lesson 11-5	Solving Two-Step Inequalities	87
Lesson 11-6	Systems of Equations	88

Chapter 12

Lesson 12-1	Graphing Linear Equations	89
Lesson 12-2	Slope of a Line	90
Lesson 12-3	Using Slopes and Intercepts	91
Lesson 12-4	Point-Slope Form	92
Lesson 12-5	Direct Variation	93
Lesson 12-6	Graphing Inequalities in Two Variables	94
Lesson 12-7	Lines of Best Fit	95

CONTENTS, *CONTINUED*

Chapter 13

Lesson 13-1	Terms of Arithmetic Sequences	96
Lesson 13-2	Terms of Geometric Sequences	97
Lesson 13-3	Other Sequences	98
Lesson 13-4	Linear Functions	99
Lesson 13-5	Exponential Functions	100
Lesson 13-6	Quadratic Functions	101
Lesson 13-7	Inverse Variation	102

Chapter 14

Lesson 14-1	Polynomials	103
Lesson 14-2	Simplifying Polynomials	104
Lesson 14-3	Adding Polynomials	105
Lesson 14-4	Subtracting Polynomials	106
Lesson 14-5	Multiplying Polynomials by Monomials	107
Lesson 14-6	Multiplying Binomials	108

LESSON
1-1 **Practice**
Variables and Expressions

Evaluate each expression for the given value of the variable.

1. $6x + 2$ for $x = 3$

2. $18 - a$ for $a = 13$

3. $\frac{1}{4}y$ for $y = 16$

4. $9 - 2b$ for $b = 3$

5. $44 - 12n$ for $n = 3$

6. $7.2 + 8k$ for $k = 2$

7. $20(b - 15)$ for $b = 19$

8. $n(18 - 5)$ for $n = 4$

Evaluate each expression for the given value of the variables.

9. $2x + y$ for $x = 7$ and $y = 11$

10. $4j - k$ for $j = 4$ and $k = 10$

11. $9a - 6b$ for $a = 6$ and $b = 2$

12. $5s + 5t$ for $s = 15$ and $t = 12$

13. $7(n - m)$ for $m = 4$ and $n = 15$

14. $w(14 - y)$ for $w = 8$ and $y = 5$

If q is the number of quarts of lemonade, then $\frac{1}{4}q$ can be used to find the number of cups of lemonade mix needed to make the lemonade. How much mix is needed to make each amount of lemonade?

15. 2 quarts

16. 8 quarts

17. 12 quarts

18. 18 quarts

19. If m is the number of minutes a taxi ride lasts, then $2 + 0.35m$ can be used to find the cost of a taxi ride with Bill's Taxi Company.

How much will it cost for a 12-min taxi ride? _____

LESSON **Practice**
1-2 *Algebraic Expressions*

Write an algebraic expression for each word phrase.

1. 6 less than twice x

2. 1 more than the quotient of 21 and b

3. 3 times the sum of b and 5

4. 10 times the difference of d and 3

5. the sum of 11 times s and 3

6. 7 minus the product of 2 and x

Write a word phrase for each algebraic expression.

7. $2n + 4$

8. $3r - 1$

9. $10 - 6n$

10. $7 + \frac{2}{c}$

11. $15x - 12$

12. $\frac{y}{5} + 8$

13. Maddie earns \$8 per hour. Write an algebraic expression to evaluate how much money Maddie will earn if she works for 15, 20, 25, or 30 hours.

n		Earnings
15		
20		
25		
30		

14. Write a word problem that can be evaluated by the algebraic expression $y - 95$, and evaluate it for $y = 125$.

LESSON
1-3 **Practice**
Integers and Absolute Value

Write the integers in order from least to greatest.

1. 7, 3, -9

2. -6, 2, -5

3. -4, 1, -1

4. -8, 2, -11

5. -12, -15, 0

6. -24, -17, 30

7. 16, -14, -7

8. -9, -7, -16

9. -19, -23, -10

Find the additive inverse of each integer.

10. -8

11. 6

12. -14

13. 29

Evaluate each expression.

14. $|-8| + |-4|$

15. $|-12| + |12|$

16. $|19| + |-8|$

17. $|29 - 16|$

18. $|35 - 9|$

19. $|14 - 14|$

20. $|-15| + |10|$

21. $|-9| + |30|$

22. $|24| + |-8|$

23. Natalie keeps track of her bowling scores. The scores for the games she played this Saturday relative to her best score last Saturday are Game A, 6; Game B, -3; Game C, 8; and Game D, -5. Use $<$, $>$, or $=$ to compare her first two games. Then list her games in order from the lowest score to the highest.
- _____

LESSON **Practice**
1-4 **Adding Integers**

Use a number line to find each sum.

1. $3 + 1$

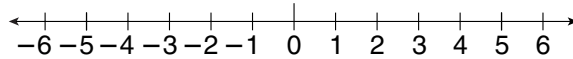

2. $-3 + 2$

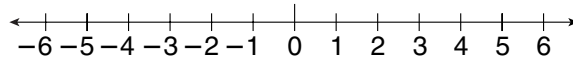

Add.

3. $-5 + 18$

4. $-10 + 17$

5. $-22 + (-9)$

6. $24 + (-15)$

Evaluate each expression for the given value of the variable.

7. $r + 7$ for $r = 3$

8. $m + 5$ for $m = 9$

9. $x + 9$ for $x = 4$

10. $-6 + t$ for $t = -8$

11. $-7 + y$ for $y = -4$

12. $x + 9$ for $x = -8$

13. $-5 + d$ for $d = -2$

14. $x + (-4)$ for $x = -4$

15. $k + (-3)$ for $k = -5$

16. $-8 + b$ for $b = 13$

17. $-10 + d$ for $d = -2$

18. $t + (-3)$ for $t = 3$

19. Joleen has 2560 trading cards in her collection. She buys 165 new cards for the collection. How many trading cards does she have now?

20. The running back for the Bears carries the ball twice in the first quarter. The first run he gained fifteen yards and the second run he lost eight yards. How many yards did the two runs total?

LESSON
1-5 **Practice**
Subtracting Integers**Subtract.**

1. $8 - 2$

2. $10 - 5$

3. $7 - 12$

4. $16 - 10$

5. $3 - 10$

6. $16 - 9$

7. $-4 - 9$

8. $-8 - 10$

9. $33 - 57$

10. $16 - 49$

11. $-114 - 19$

12. $-88 - (-10)$

Evaluate each expression for the given value of the variable.

13. $x - 8$ for $x = 10$

14. $w - 10$ for $w = 15$

15. $15 - w$ for $w = 8$

16. $12 - t$ for $t = -8$

17. $15 - x$ for $x = -12$

18. $w - 20$ for $w = -15$

19. $-15 - x$ for $x = -10$

20. $-9 - x$ for $x = -20$

21. $-11 - d$ for $d = -15$

22. $y - (-10)$ for $y = -10$

23. $x - (-15)$ for $x = -5$

24. $a - (-12)$ for $a = 10$

25. The altitude of Mt. Blackburn in Alaska is 16,390 feet. The altitude of Mt. Elbert in Colorado is 14,433 feet. What is the difference in the altitudes of the two mountains?

26. In January, Jesse weighed 230 pounds. By November, he weighed 185 pounds. How much did Jesse's weight change?

LESSON

Practice**1-6*****Multiplying and Dividing Integers*****Multiply or divide.**

1. $6 \cdot 7$

2. $\frac{-15}{5}$

3. $-7 \cdot 3$

4. $\frac{20}{-4}$

5. $\frac{-36}{-4}$

6. $-8(-9)$

7. $\frac{-48}{-6}$

8. $7(-7)$

9. $5(-8)$

10. $(-6)(-9)$

11. $\frac{-36}{4}$

12. $\frac{42}{-7}$

13. $-9(-3)$

14. $(-4)(8)$

15. $\frac{-54}{-9}$

16. $\frac{-72}{8}$

Simplify.

17. $-5(3 + 7)$

18. $10(8 - 2)$

19. $-4(12 - 3)$

20. $9(15 - 8)$

21. $12(-9 + 4)$

22. $-11(7 - 13)$

23. $15(-12 + 8)$

24. $-10(-8 - 6)$

25. $6(-12 + 1)$

26. $-5(3 - 12)$

27. $-8(-5 - 5)$

28. $7(12 - 3)$

29. $10(-7 - 1)$

30. $12(2 - 5)$

31. $-15(-2 - 1)$

32. $9(8 - 20)$

33. Kristin and her three friends buy a pizza with twelve slices and split it equally. How many slices will each person receive?

34. The temperature was -1°F , -5°F , 8°F , and -6°F on four consecutive days. What was the average temperature for those days?

LESSON **Practice****1-7** *Solving Equations by Adding or Subtracting*

Determine which value is a solution of the equation.

1. $x - 6 = 12$; $x = 6, 8, \text{ or } 18$

2. $9 + x = 17$; $x = 6, 8, \text{ or } 26$

3. $x - 12 = 26$; $x = 14, 38, \text{ or } 40$

4. $x + 18 = 59$; $x = 37, 41, \text{ or } 77$

Solve.

5. $n - 8 = 11$

6. $9 + g = 13$

7. $y + 6 = 2$

8. $-6 + j = -12$

9. $s - 8 = 11$

10. $-16 + r = -2$

11. $a + 35 = 51$

12. $m - 6 = -13$

13. $d - 12 = -5$

14. $7.5 + c = 10.6$

15. $y - 1.7 = 0.6$

16. $m - 2.25 = 4.50$

17. Two sisters, Jenny and Penny, play on the same basketball team. Last season they scored a combined total of 458 points. Jenny scored 192 of the points. Write and solve an equation to find the number of points Penny scored.

18. After his payment, Mr. Weber's credit card balance was \$245.76. His payment was for \$75.00. Write and solve an equation to find the amount of his credit card bill.

LESSON **Practice**
1-8 *Solving Equations by Multiplying or Dividing***Solve and check.**

1. $4w = 48$

2. $8y = 56$

3. $-4b = 64$

4. $\frac{x}{4} = -9$

5. $\frac{v}{-6} = -14$

6. $\frac{n}{21} = -3$

7. $5a = -75$

8. $54 = 3q$

9. $23b = 161$

10. $\frac{k}{21} = 15$

11. $\frac{w}{-17} = 17$

12. $11 = \frac{r}{34}$

13. $672 = -24b$

14. $\frac{u}{25} = 13$

15. $42m = -966$

16. $3x + 7 = 16$

17. $\frac{t}{5} + 8 = 10$

18. $5 = 2n - 3$

19. Alex scored 13 points in the basketball game. This was $\frac{1}{5}$ of the total points the team scored. Write and solve an equation to determine the total points t the team scored.

20. Jar candles at the Candle Co. cost \$4. Nikki spent \$92 buying jar candles for party favors. Write and solve an equation to determine how many jar candles c Nikki bought at the Candle Co.

LESSON **Practice**
1-9 *Introduction to Inequalities*

Compare each inequality. Write $<$ or $>$.

1. $7 + 10 \square 16$

2. $21 \square 4(5)$

3. $25 - 7 \square 19$

4. $58 \square 7(8)$

5. $-4(8) \square -30$

6. $3 - 8 \square -2$

7. $7 + (-7) \square -17$

8. $9(-7) \square -70$

9. $-43 + (-18) \square -23$

Solve and graph each inequality.

10. $x + 4 > 9$



11. $c - 6 \leq 1$

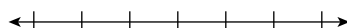

12. $y + 3 \geq -8$

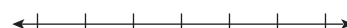

13. $3 + v < -5$



14. $7 + x \leq 10$

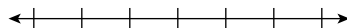

15. $s - 4 < -10$



16. $b - 2 \leq 5$

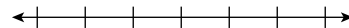

17. $7 + n > -2$

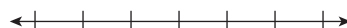

18. $r + 6 \geq -1$



19. $-9 + w < -15$



20. $14 + k > 25$



21. $a - 8 \geq -12$



22. $k + 3 \leq 0$

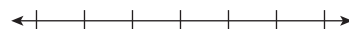

23. $n + 6 \geq 2$



24. $-1 + b \leq -1$



LESSON
2-1 **Practice**
Rational Numbers**Simplify.**

1. $\frac{6}{9}$

2. $\frac{48}{96}$

3. $\frac{13}{52}$

4. $-\frac{7}{28}$

5. $\frac{15}{40}$

6. $-\frac{4}{48}$

7. $-\frac{14}{63}$

8. $\frac{12}{72}$

Write each decimal as a fraction in simplest form.

9. 0.72

10. 0.058

11. -1.65

12. 2.1

13. 0.036

14. -4.06

15. 2.305

16. 0.0064

17. -0.60

18. 6.95

19. 0.016

20. 0.0005

Write each fraction as a decimal.

21. $\frac{1}{8}$

22. $\frac{8}{3}$

23. $\frac{14}{15}$

24. $\frac{16}{5}$

25. $\frac{11}{16}$

26. $\frac{7}{9}$

27. $\frac{4}{5}$

28. $\frac{31}{25}$

29. Make up a fraction that cannot be simplified that has 24 as its denominator.

LESSON
2-2 Practice
Comparing and Ordering Rational NumbersCompare. Write $<$, $>$, or $=$.

1. $\frac{1}{8} \square \frac{1}{10}$

2. $\frac{3}{5} \square \frac{7}{10}$

3. $-\frac{1}{3} \square -\frac{3}{4}$

4. $\frac{5}{6} \square \frac{3}{4}$

5. $-\frac{2}{7} \square -\frac{1}{2}$

6. $1\frac{2}{9} \square 1\frac{2}{3}$

7. $-\frac{8}{9} \square -\frac{3}{10}$

8. $-\frac{4}{5} \square -\frac{8}{10}$

9. $0.08 \square \frac{3}{10}$

10. $\frac{11}{15} \square 0.7\bar{3}$

11. $2\frac{4}{9} \square 2\frac{3}{4}$

12. $-\frac{5}{8} \square -0.58$

13. $3\frac{1}{4} \square 3.3$

14. $-\frac{1}{6} \square -\frac{1}{9}$

15. $0.75 \square \frac{3}{4}$

16. $-2\frac{1}{8} \square -2.1$

17. $1\frac{1}{2} \square 1.456$

18. $-\frac{3}{5} \square -0.6$

19. On Monday, Gina ran 1 mile in 9.3 minutes. Her times for running 1 mile on each of the next four days, relative to her time on Monday, were $-1\frac{2}{3}$ minutes, -1.45 minutes, -1.8 minutes, and $-1\frac{3}{8}$ minutes. List these relative times in order from least to greatest.
-

20. Trail A is 3.1 miles long. Trail C is $3\frac{1}{4}$ miles long. Trail B is longer than Trail A but shorter than Trail C. What is a reasonable distance for the length of Trail B?
-

LESSON **Practice**
2-3 **Adding and Subtracting Rational Numbers**

1. Gretchen bought a sweater for \$23.89. In addition, she had to pay \$1.43 in sales tax. She gave the sales clerk \$30. How much change did Gretchen receive from her total purchase?

2. Jacob is replacing the molding around two sides of a picture frame. The measurements of the sides of the frame are $4\frac{3}{16}$ in. and $2\frac{5}{16}$ in. What length of molding will Jacob need?

Use a number line to find each sum.

3. $-0.5 + 0.4$

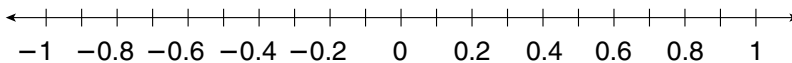

4. $-\frac{2}{7} + \frac{6}{7}$

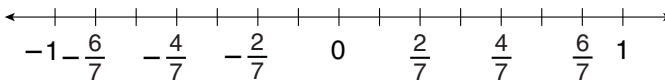

Add or subtract. Simplify.

5. $\frac{3}{8} + \frac{1}{8}$

6. $-\frac{1}{10} + \frac{7}{10}$

7. $\frac{5}{14} - \frac{3}{14}$

8. $\frac{4}{15} + \frac{7}{15}$

9. $\frac{5}{18} - \frac{7}{18}$

10. $-\frac{8}{17} - \frac{2}{17}$

11. $-\frac{1}{16} + \frac{5}{16}$

12. $\frac{3}{20} + \frac{1}{20}$

Evaluate each expression for the given value of the variable.

13. $38.1 + x$ for $x = -6.1$

14. $18.7 + x$ for $x = 8.5$

15. $\frac{8}{15} + x$ for $x = -\frac{4}{15}$

LESSON
2-4 Practice
Multiplying Rational Numbers**Multiply. Write each answer in simplest form.**

1. $8\left(\frac{3}{4}\right)$

2. $-6\left(\frac{9}{18}\right)$

3. $-9\left(\frac{5}{6}\right)$

4. $-6\left(-\frac{7}{12}\right)$

5. $-\frac{5}{18}\left(\frac{8}{15}\right)$

6. $\frac{7}{12}\left(\frac{14}{21}\right)$

7. $-\frac{1}{9}\left(\frac{27}{24}\right)$

8. $-\frac{1}{11}\left(-\frac{3}{2}\right)$

9. $\frac{7}{20}\left(-\frac{15}{28}\right)$

10. $\frac{16}{25}\left(-\frac{18}{32}\right)$

11. $\frac{1}{9}\left(-\frac{18}{17}\right)$

12. $\frac{17}{20}\left(-\frac{12}{34}\right)$

13. $-4\left(2\frac{1}{6}\right)$

14. $\frac{3}{4}\left(1\frac{3}{8}\right)$

15. $3\frac{1}{5}\left(\frac{2}{3}\right)$

16. $-\frac{5}{6}\left(2\frac{1}{2}\right)$

Multiply.

17. $-2(-5.2)$

18. $0.53(0.04)$

19. $(-7)(-3.9)$

20. $-2(8.13)$

21. $0.02(-4.62)$

22. $0.5(-7.8)$

23. $(-0.41)(-8.5)$

24. $(-8)(6.3)$

25. $15(-0.05)$

26. $(-3.04)(-1.7)$

27. $10(-0.09)$

28. $(-0.8)(-0.15)$

29. Travis painted for $6\frac{2}{3}$ hours. He received \$27 an hour for his work. How much was Travis paid for doing this painting job?

LESSON **Practice**
2-5 **Dividing Rational Numbers**

Divide. Write each answer in simplest form.

1. $\frac{1}{5} \div \frac{3}{10}$

2. $-\frac{5}{8} \div \frac{3}{4}$

3. $\frac{1}{4} \div \frac{1}{8}$

4. $-\frac{2}{3} \div \frac{4}{15}$

5. $1\frac{2}{9} \div 1\frac{2}{3}$

6. $-\frac{7}{10} \div \left(\frac{2}{5}\right)$

7. $\frac{6}{11} \div \frac{3}{22}$

8. $\frac{4}{9} \div \left(-\frac{8}{15}\right)$

9. $\frac{3}{8} \div -15$

10. $-\frac{5}{6} \div 12$

11. $6\frac{1}{2} \div 1\frac{5}{8}$

12. $-\frac{9}{10} \div 6$

Divide.

13. $24.35 \div 0.5$

14. $2.16 \div 0.04$

15. $3.16 \div 0.02$

16. $7.32 \div 0.3$

17. $87.36 \div 0.6$

18. $79.36 \div 0.8$

19. $4.27 \div 0.007$

20. $63.81 \div 0.9$

21. $1.23 \div 0.003$

22. $62.46 \div 0.09$

23. $21.12 \div 0.4$

24. $82.68 \div 0.06$

Evaluate each expression for the given value of the variable.

25. $\frac{18}{x}$ for $x = 0.12$

26. $\frac{10.8}{x}$ for $x = 0.03$

27. $\frac{9.18}{x}$ for $x = -1.2$

28. A can of fruit contains $3\frac{1}{2}$ cups of fruit. The suggested serving size is $\frac{1}{2}$ cup. How many servings are in the can of fruit?

LESSON **Practice**
2-6 *Adding and Subtracting with Unlike Denominators*

Add or subtract.

1. $\frac{2}{3} + \frac{1}{2}$

2. $\frac{3}{5} + \frac{1}{3}$

3. $\frac{3}{4} - \frac{1}{3}$

4. $\frac{1}{2} - \frac{5}{9}$

5. $\frac{5}{16} - \frac{5}{8}$

6. $\frac{7}{9} + \frac{5}{6}$

7. $\frac{7}{8} - \frac{1}{4}$

8. $\frac{5}{6} - \frac{3}{8}$

9. $2\frac{7}{8} + 3\frac{5}{12}$

10. $1\frac{2}{9} + 2\frac{1}{18}$

11. $3\frac{2}{3} - 1\frac{3}{5}$

12. $1\frac{5}{6} + (-2\frac{3}{4})$

13. $8\frac{1}{3} - 3\frac{5}{9}$

14. $5\frac{1}{3} + 1\frac{11}{12}$

15. $7\frac{1}{4} + (-2\frac{5}{12})$

16. $5\frac{2}{5} - 7\frac{3}{10}$

Evaluate each expression for the given value of the variable.

17. $2\frac{3}{8} + x$ for $x = 1\frac{5}{6}$

18. $x - \frac{2}{5}$ for $x = \frac{1}{3}$

19. $x - \frac{3}{10}$ for $x = \frac{3}{7}$

20. $1\frac{5}{8} + x$ for $x = -2\frac{1}{6}$

21. $x - \frac{3}{4}$ for $x = \frac{1}{6}$

22. $x - \frac{3}{10}$ for $x = \frac{1}{2}$

23. Ana worked $6\frac{1}{2}$ h on Monday, $5\frac{3}{4}$ h on Tuesday and $7\frac{1}{6}$ h on Friday. How many total hours did she work these three days?

LESSON **Practice**
2-7 **Solving Equations with Rational Numbers**

Solve.

1. $x + 6.8 = 12.19$

2. $y - 10.24 = 5.3$

3. $0.05w = 6.25$

4. $\frac{a}{9.05} = 8.2$

5. $-12.41 + x = -0.06$

6. $\frac{d}{-8.4} = -10.2$

7. $-2.89 = 1.7m$

8. $n - 8.09 = -11.65$

9. $\frac{x}{5.4} = -7.18$

10. $\frac{7}{9} + x = 1\frac{1}{9}$

11. $\frac{6}{11}y = -\frac{18}{22}$

12. $\frac{7}{10}d = \frac{21}{20}$

13. $x - \left(-\frac{9}{14}\right) = \frac{5}{7}$

14. $x - \frac{15}{21} = 2\frac{6}{7}$

15. $-\frac{8}{15}a = \frac{9}{10}$

16. A recipe calls for $2\frac{1}{3}$ cups of flour and $1\frac{1}{4}$ cups of sugar. If the recipe is tripled, how much flour and sugar will be needed?

17. Daniel filled the gas tank in his car with 14.6 gal of gas. He then drove 284.7 mi before needing to fill up his tank with gas again. How many miles did the car get to a gallon of gasoline?

LESSON **Practice**
2-8 Solving Two-Step Equations

Write and solve a two-step equation to answer the following questions.

1. The school purchased baseball equipment and uniforms for a total cost of \$1762. The equipment costs \$598 and the uniforms were \$24.25 each. How many uniforms did the school purchase?

2. Carla runs 4 miles every day. She jogs from home to the school track, which is $\frac{3}{4}$ mile away. She then runs laps around the $\frac{1}{4}$ -mile track. Carla then jogs home. How many laps does she run at the school?

Solve.

3. $\frac{a+5}{3} = 12$

4. $\frac{x+2}{4} = -2$

5. $\frac{y-4}{6} = -3$

6. $\frac{k+1}{8} = 7$

7. $0.5x - 6 = -4$

8. $\frac{x}{2} + 3 = -4$

9. $\frac{1}{5}n + 3 = 6$

10. $2a - 7 = -9$

11. $\frac{3x-1}{4} = 2$

12. $-7.8 = 4.4 + 2r$

13. $\frac{-4w+5}{-3} = -7$

14. $1.3 - 5r = 7.4$

15. A phone call costs \$0.58 for the first 3 minutes and \$0.15 for each additional minute. If the total charge for the call was \$4.78, how many minutes was the call?

16. Seventeen less than four times a number is twenty-seven. Find the number.

LESSON **Practice**
3-1 **Ordered Pairs**

Determine whether each ordered pair is a solution of $y = 4 + 2x$.

1. (1, 1) 2. (2, 8) 3. (0, 4) 4. (8, 2)

Determine whether each ordered pair is a solution of $y = 3x - 2$.

5. (1, 1) 6. (3, 7) 7. (5, 15) 8. (6, 16)

Use the given values to complete the table of solutions.

9. $y = x + 5$ for $x = 0, 1, 2, 3, 4$

x	$x + 5$	y	(x, y)
0			
1			
2			
3			
4			

10. $y = 3x + 1$ for $x = 1, 2, 3, 4, 5$

x	$3x + 1$	y	(x, y)
1			
2			
3			
4			
5			

11. $y = 2x + 6$ for $x = 0, 1, 2, 3, 4$

x	$2x + 6$	y	(x, y)
0			
1			
2			
3			
4			

12. $y = 4x - 2$ for $x = 2, 4, 6, 8, 10$

x	$4x - 2$	y	(x, y)
2			
4			
6			
8			
10			

13. Alexis opened a savings account with a \$120 deposit. Each week she will put \$20 into the account. The equation that gives the total amount t in her account is $t = 120 + 20w$, where w is the number of weeks since she opened the account. How much money will Alexis have in her savings account after 5 weeks?

LESSON

3-2

Practice

Graphing on a Coordinate Plane

Give the coordinates of each point and quadrant.

- | | |
|-------------|-------------|
| 1. <i>F</i> | 2. <i>X</i> |
| _____ | _____ |
| 3. <i>T</i> | 4. <i>B</i> |
| _____ | _____ |
| 5. <i>D</i> | 6. <i>R</i> |
| _____ | _____ |
| 7. <i>H</i> | 8. <i>Y</i> |
| _____ | _____ |

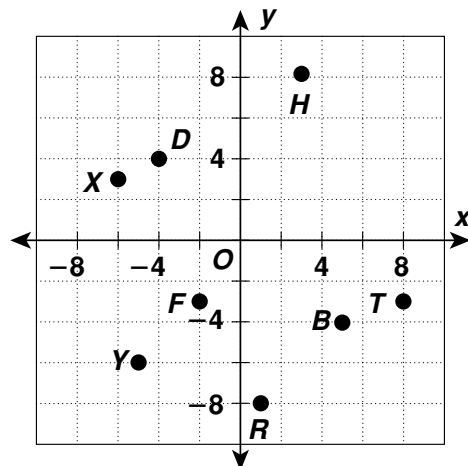

Graph each point on a coordinate plane.

- | | |
|---------------------------|----------------------------|
| 9. $A(2\frac{1}{2}, 1)$ | 10. $B(0, 4)$ |
| 11. $C(2, -1.5)$ | 12. $D(-2, 3.5)$ |
| 13. $E(-2\frac{1}{3}, 0)$ | 14. $F(-1\frac{1}{2}, -3)$ |

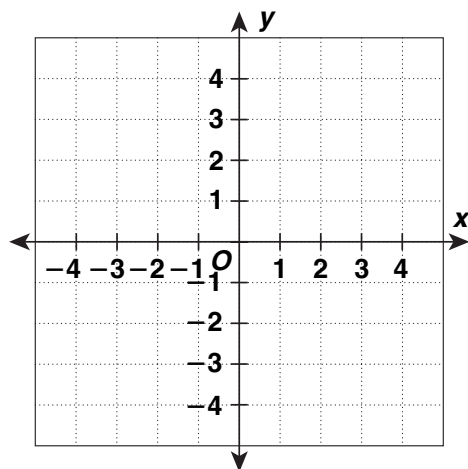

Complete the table of ordered pairs. Graph each ordered pair on a coordinate plane. Draw a line through the points.

15. $y = 1\frac{1}{2}x$

<i>x</i>	$1\frac{1}{2}x$	<i>y</i>	(<i>x</i> , <i>y</i>)
0			
1			
2			

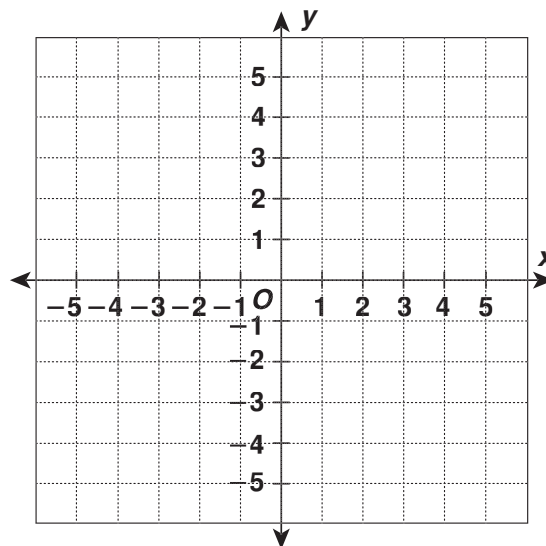

LESSON **Practice**
3-3 *Interpreting Graphs and Tables*

The table gives the speed of three dogs in mi/h at the given times. Tell which dog corresponds to each situation described below.

Time	5:00	5:01	5:02	5:03	5:04
Dog 1	0	1	12	0	0
Dog 2	5	23	4	0	0
Dog 3	14	0	18	2	9

1. Leshaan walks his dog. Then he lets the dog off the leash and it runs around the yard. Then they go into the house and the dog stands eating from his dog dish and drinking from his water bowl.

2. Luke’s dog is chasing its tail. Then it stops and pants. The dog then runs to the backyard fence and walks along the fence, barking at a neighbor. Then it runs to Luke at the back door.

Tell which graph corresponds to each situation in Exercises 1–2.

3.

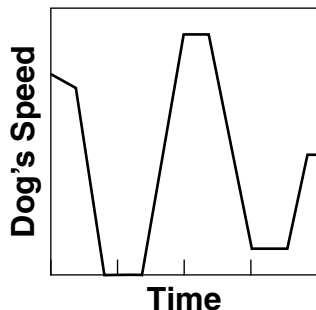

4.

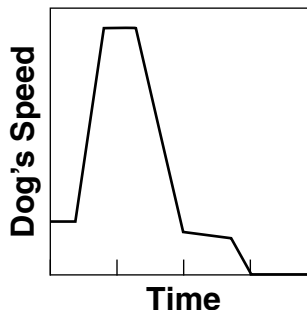

5. Create a graph that illustrates the temperature inside the car.

Location	Temperature on Arrival	Temperature on Departure
Home	—	74° at 8:30
Summer job	77° at 9:00	128° at 12:05
Pool	92° at 12:15	136° at 2:30
Library	95° at 2:40	77° at 5:10

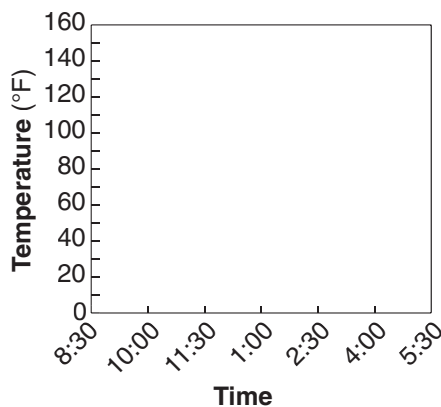

LESSON **Practice**
3-4 **Functions**

Complete the table and graph each function.

1. $y = -2x + 5$

x	$-2x + 5$	y
-2		
-1		
0		
1		
2		

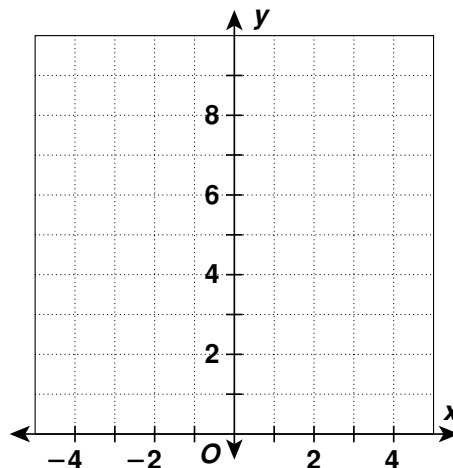

2. $y = x - 2$

x	$x - 2$	y
-2		
-1		
0		
1		
2		

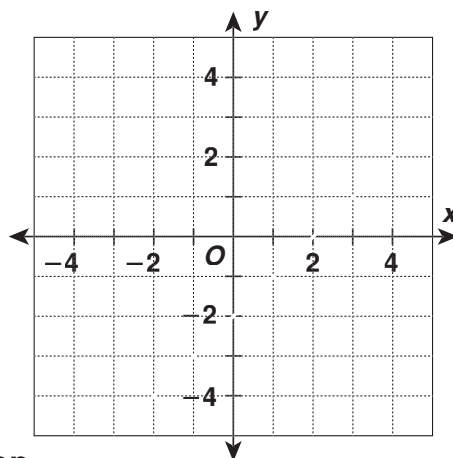

Determine if each relationship represents a function.

3. $y = \frac{1}{3}x - \frac{2}{5}$

4.

x	1	2	1	2
y	6	5	-6	-5

5.

x	y
0	0
1	-1
2	-8
3	-27
4	-64

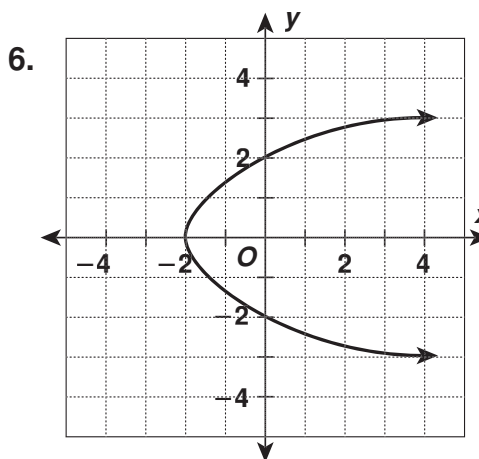

LESSON

Practice

3-5 Equations, Tables, and Graphs

1. The amount of water in a tank being filled is represented by the equation $g = 20m$, where g is the number of gallons in the tank after m minutes. Make a table and sketch a graph of the equation.

m	$20m$	g
0		
1		
2		
3		
4		

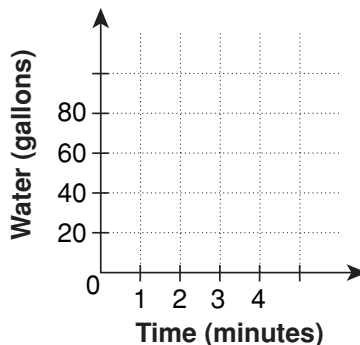

2. Use the table to make a graph and to write an equation.

x	0	2	5	8	12
y	4	6	9	12	16

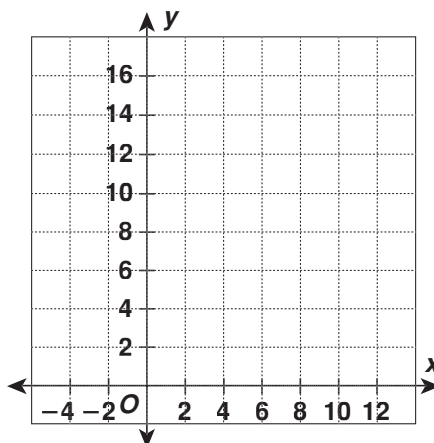

3. Use the graph to make a table and to write an equation.

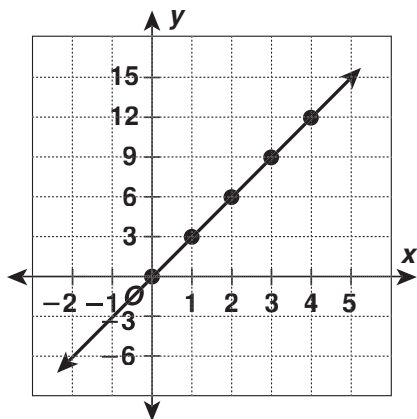

x					
y					

LESSON

3-6

Practice**Arithmetic Sequences**

Find the common difference in each arithmetic sequence.

1. 5, 9, 13, 17, ...

2. 3, 10, 17, 24, ...

3. 35, 32, 29, 26, ...

4. 6, 15, 24, 33, ...

5. 92, 87, 82, 77, ...

6. 60, 54, 48, 42, ...

7. 108, 96, 84, 72, ...

8. 3.8, 4, 4.2, 4.4, ...

9. 95, 88, 81, 74, ...

Find the next three terms in each arithmetic sequence.

10. 12, 18, 24, 30, ...

11. $1\frac{1}{2}$, 2, $2\frac{1}{2}$, 3, ...

12. -7, -14, -21, -28, ...

13. 0.5, 1, 1.5, 2, ...

14. -8, -16, -24, -32, ...

15. 72, 63, 54, 45, ...

16. 3.5, 7, 10.5, 14, ...

17. $\frac{1}{3}$, $\frac{2}{3}$, 1, $1\frac{1}{3}$, ...

18. 10, 9.5, 9, 8.5, ...

Find a function that describes each arithmetic sequence. Use y to identify each term in the sequence and n to identify each term's position.

19. 6, 12, 18, 24, ...

20. -8, -16, -24, -32, ...

21. 12, 24, 36, 48, ...

22. It costs \$12 to rent a mini-car to go around the track, plus \$4 per lap. Find a function that describes the sequence. Then find the total cost of driving 5 laps around the track.

LESSON
4-1 Practice
Exponents

Write in exponential form.

1. $6 \cdot 6 \cdot 6 \cdot 6 \cdot 6 \cdot 6$

2. $7 \cdot 7 \cdot 7 \cdot 7$

3. $(-8) \cdot (-8) \cdot (-8) \cdot (-8)$

4. $5 \cdot 5 \cdot 5 \cdot b \cdot b \cdot b \cdot b$

Evaluate.

5. 10^2

6. $(-6)^2$

7. 8^2

8. $(-7)^2$

9. $(-5)^3$

10. 12^2

11. $(-9)^2$

12. $(-4)^3$

13. 2^5

14. 5^4

15. $(-3)^4$

16. 6^3

Evaluate each expression for the given values of the variables.

17. $n^3 - 5$ for $n = 4$

18. $4x^2 + y^3$ for $x = 5$ and $y = -2$

19. $m^p + q^2$ for $m = 5$, $p = 2$, and $q = 4$

20. $a^4 + 2(b - c^2)$ for $a = 2$, $b = 4$, and $c = -1$

21. Write an expression for five times a number used as a factor three times.
_____22. Find the volume of a regular cube if the length of a side is 10 cm. (Hint: $V = l^3$.)

LESSON

Practice**4-2*****Look for a Pattern in Integer Exponents***

Evaluate the powers of 10.

1. 10^{-3}

2. 10^3

3. 10^{-5}

4. 10^{-2}

5. 10^0

6. 10^4

7. 10^1

8. 10^5

Evaluate.

9. $(-6)^{-2}$

10. $(-9)^{-3}$

11. 2^{-5}

12. $(-3)^{-4}$

13. $(-12)^{-1}$

14. 6^{-3}

15. $10 - (3 + 2)^0 + 2^{-1}$

16. $15 + (-6)^0 - 3^{-2}$

17. $6(8 - 2)^0 + 4^{-2}$

18. $2^{-2} + (-4)^{-1}$

19. $3(1 - 4)^{-2} + 9^{-1} + 12^0$

20. $9^0 + 64(3 + 5)^{-2}$

21. One milliliter equals 10^{-3} liter. Evaluate 10^{-3} .

22. The volume of a cube is 10^6 cubic feet. Evaluate 10^6 .

LESSON **Practice**
4-3 *Properties of Exponents*

Multiply. Write the product as one power.

1. $10^5 \cdot 10^7$

2. $x^9 \cdot x^8$

3. $14^7 \cdot 14^9$

4. $12^6 \cdot 12^8$

5. $y^{12} \cdot y^{10}$

6. $15^9 \cdot 15^{14}$

7. $(-11)^{20} \cdot (-11)^{10}$

8. $(-a)^6 \cdot (-a)^7$

Divide. Write the quotient as one power.

9. $\frac{12^9}{12^2}$

10. $\frac{(-11)^{12}}{(-11)^8}$

11. $\frac{x^{10}}{x^5}$

12. $\frac{16^{10}}{16^2}$

13. $\frac{17^{19}}{17^2}$

14. $\frac{14^{15}}{14^{13}}$

15. $\frac{23^{17}}{23^9}$

16. $\frac{(-a)^{12}}{(-a)^7}$

Simplify.

17. $(6^2)^4$

18. $(2^4)^{-3}$

19. $(3^5)^{-1}$

20. $(y^5)^2$

21. $(9^{-2})^3$

22. $(10^0)^3$

23. $(x^4)^{-2}$

24. $(5^{-2})^0$

Write the product or quotient as one power.

25. $\frac{w^{12}}{w^3}$

26. $d^8 \cdot d^5$

27. $(-15)^5 \cdot (-15)^{10}$

28. Jefferson High School has a student body of 6^4 students. Each class has approximately 6^2 students. How many classes does the school have? Write the answer as one power.

29. Write the expression for a number used as a factor fifteen times being multiplied by a number used as a factor ten times. Then, write the product as one power.

LESSON

4-4**Practice****Scientific Notation**

Write each number in standard notation.

1. 2.54×10^2

2. 6.7×10^{-2}

3. 1.14×10^3

4. 3.8×10^{-1}

5. 7.53×10^{-3}

6. 5.6×10^4

7. 9.1×10^5

8. 6.08×10^{-4}

9. 8.59×10^5

10. 3.331×10^6

11. 7.21×10^{-3}

12. 5.88×10^{-4}

Write each number in scientific notation.

13. 75,000,000

14. 208

15. 907,100

16. 56

17. 0.093

18. 0.00006

19. 0.00852

20. 0.0505

21. 0.003007

22. 5226

23. 0.04

24. 98,856

25. Jupiter is about 778,120,000 kilometers from the Sun. Write this number in scientific notation.

26. The *E. coli* bacterium is about 5×10^{-7} meters wide. A hair is about 1.7×10^{-5} meters wide. Which is wider, the bacterium or the hair?

LESSON
4-5 **Practice**
Squares and Square Roots

Find the two square roots of each number.

1. 36

2. 81

3. 49

4. 100

5. 64

6. 121

7. 25

8. 144

Evaluate each expression.

9. $\sqrt{32 + 17}$

10. $\sqrt{100 - 19}$

11. $\sqrt{64 + 36}$

12. $\sqrt{73 - 48}$

13. $2\sqrt{64} + 10$

14. $36 - \sqrt{36}$

15. $\sqrt{100} - \sqrt{25}$

16. $\sqrt{121} + 16$

17. $\sqrt{\frac{25}{4}} + \frac{1}{2}$

18. $\sqrt{\frac{100}{25}}$

19. $\sqrt{\frac{196}{49}}$

20. $3(\sqrt{144} - 6)$

The Pyramids of Egypt are often called the first wonder of the world. This group of pyramids consists of Menkaura, Khufu, and Khafra. The largest of these is Khufu, sometimes called Cheops. During this time in history, each monarch had his own pyramid built to bury his mummified body. Cheops was a king of Egypt in the early 26th century B.C. His pyramid's original height is estimated to have been 482 ft. It is now approximately 450 ft. The estimated completion date of this structure was 2660 B.C.

21. If the area of the base of Cheops' pyramid is $570,025 \text{ ft}^2$, what is the length of one of the sides of the ancient structure?
(Hint: $s = \sqrt{A}$)
- _____

22. If a replica of the pyramid were built with a base area of 625 in^2 , what would be the length of each side?
(Hint: $s = \sqrt{A}$)
- _____

LESSON
4-6 Practice
Estimating Square Roots

Each square root is between two integers. Name the integers.
Explain your answer.

1. $\sqrt{6}$

2. $\sqrt{20}$

3. $\sqrt{28}$

4. $\sqrt{44}$

5. $\sqrt{31}$

6. $\sqrt{52}$

Use a calculator to find each value. Round to the nearest tenth.

7. $\sqrt{14}$

8. $\sqrt{42}$

9. $\sqrt{21}$

10. $\sqrt{47}$

11. $\sqrt{58}$

12. $\sqrt{60}$

13. $\sqrt{35}$

14. $\sqrt{75}$

Police use the formula $r = 2\sqrt{5L}$ to approximate the rate of speed in miles per hours of a vehicle from its skid marks, where L is the length of the skid marks in feet.

15. About how fast is a car going that leaves skid marks of 80 ft?

16. About how fast is a car going that leaves skid marks of 245 ft?

17. If the formula for finding the length of the skid marks is $L = \frac{r^2}{20}$, what would be the length of the skid marks from a vehicle traveling 80 mi/h?

LESSON
4-7 **Practice**
The Real Numbers

Write all names that apply to each number.

1. $-\frac{7}{8}$

2. $\sqrt{0.15}$

3. $\sqrt{\frac{18}{2}}$

4. $\sqrt{45}$

5. -25

6. -6.75

State if the number is rational, irrational, or not a real number.

7. $\sqrt{14}$

8. $\sqrt{-16}$

9. $\frac{6.2}{0}$

10. $\sqrt{49}$

11. $\frac{7}{20}$

12. $-\sqrt{81}$

13. $\sqrt{\frac{7}{9}}$

14. -1.3

Find a real number between each pair of numbers.

15. $7\frac{3}{5}$ and $7\frac{4}{5}$

16. 6.45 and $\frac{13}{2}$

17. $\frac{7}{8}$ and $\frac{9}{10}$

18. Give an example of a rational number between $-\sqrt{4}$ and $\sqrt{4}$

19. Give an example of an irrational number less than 0.

20. Give an example of a number that is not real.

LESSON **Practice**
4-8 *The Pythagorean Theorem*

Find the length of the hypotenuse to the nearest tenth.

1.

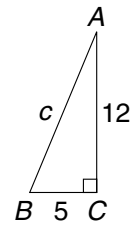

2.

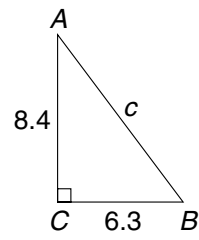

3.

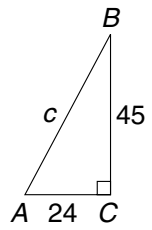

Solve for the unknown side in each right triangle to the nearest tenth.

4.

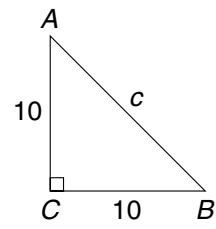

5.

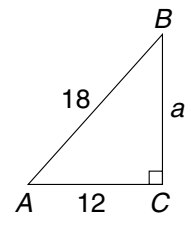

6.

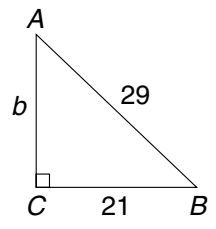

7.

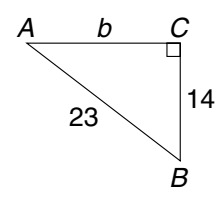

8.

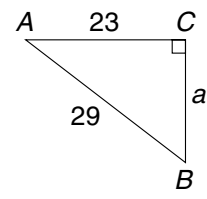

9.

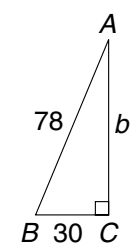

10. A glider flies 8 miles south from the airport and then 15 miles east. Then it flies in a straight line back to the airport. What was the distance of the glider's last leg back to the airport?

LESSON **Practice**
5-1 *Ratios and Proportions*

Find two ratios that are equivalent to each given ratio.

1. $\frac{9}{12}$

2. $\frac{4}{20}$

3. $\frac{15}{25}$

4. $\frac{7}{12}$

5. $\frac{14}{7}$

6. $\frac{11}{22}$

7. $\frac{10}{3}$

8. $\frac{18}{28}$

9. $\frac{12}{27}$

Simplify to tell whether the ratios form a proportion.

10. $\frac{13}{39}$ and $\frac{16}{48}$

11. $\frac{21}{49}$ and $\frac{28}{56}$

12. $\frac{12}{28}$ and $\frac{18}{42}$

13. $\frac{18}{27}$ and $\frac{10}{15}$

14. $\frac{24}{27}$ and $\frac{27}{30}$

15. $\frac{14}{10}$ and $\frac{35}{25}$

16. $\frac{10}{32}$ and $\frac{25}{80}$

17. $\frac{16}{48}$ and $\frac{15}{45}$

18. Mrs. Walters wanted one daffodil plant for every 2 tulip plants in her garden. If she planted 20 daffodil bulbs, how many tulip bulbs did she plant?

19. In a survey, 9 out of 10 doctors recommended a certain medicine. If 80 doctors were surveyed, how many doctors recommended the medicine?

20. A molecule of sodium carbonate contains 2 atoms of sodium to every 3 atoms of oxygen. Could a compound containing 12 atoms of sodium and 15 atoms of oxygen be sodium carbonate? Explain.

LESSON
5-2 Practice
Ratios, Rates, and Unit Rates

1. Copper weighing 4480 kilograms has a volume of 0.5 cubic meters. What is the density of copper?

2. Yoshi's yogurt contains 15 calories per ounce. How many calories are in an 8-ounce container of Yoshi's yogurt?

3. Emily earns \$7.50 per hour. How much does she earn in 3 hours?

Estimate the unit rate.

4. 43 apples in 5 bags

5. \$71.00 for 8 hours

6. 146 students in 6 classes

7. \$52.00 for 5 hours

8. 7 miles in 64 minutes

9. \$3.55 for 4 pounds

Determine the better buy.

10. 8.2 oz of toothpaste for \$2.99 or 6.4 oz of toothpaste for \$2.49

11. a 3 lb bag of apples for \$2.99 or a 5 lb bag of apples for \$4.99

12. 16 oz bottle of soda for \$1.25 or 20 oz bottle of soda for \$1.55

13. Mavis rides the bus every day. She bought a bus pass good for the month of October for \$38.75. How much was Mavis charged per day for the bus pass?

LESSON
5-3 **Practice**
Dimensional Analysis

Find the appropriate factor for each conversion.

1. grams to kilograms 2. quarts to gallons 3. minutes to seconds

4. David takes 300 milligrams of medicine every day. How many grams is this?

5. Jody runs the 500-yard dash for his school's track team. How many feet does he run in each 500-yard dash?

6. Sean drinks six 12-ounce cans of soda a week. How many pints of soda does he drink in a week?

7. A recipe for punch requires diluting the punch concentrate with 7 quarts of water. How many gallons of water are required to dilute the concentrate according to the directions?

8. Jesse's dog Angel weighs $18\frac{1}{2}$ pounds. How many ounces does Angel weigh?

9. A roll of tape contains 32.9 meters of tape. How many millimeters of tape does the roll contain?

10. There are two types of lifts in the sport of weightlifting, the *snatch* and the *clean and jerk*. Winners are determined by the combined weights of the two type of lifts. In the 2002 Collegiate Weightlifting Competition, Timothy Leancu from the U.S. Naval Academy competed in the 94-kilogram weight class. He lifted 100 kg in the *snatch* and 132.5 kg in the *clean and jerk*. What was the combined weight of his lifts in grams?

LESSON
5-4 **Practice**
Solving Proportions

Tell whether the ratios are proportional.

1. $\frac{3}{4} \stackrel{?}{=} \frac{9}{12}$

2. $\frac{9}{24} \stackrel{?}{=} \frac{18}{48}$

3. $\frac{16}{24} \stackrel{?}{=} \frac{10}{18}$

4. $\frac{13}{25} \stackrel{?}{=} \frac{26}{50}$

5. $\frac{10}{32} \stackrel{?}{=} \frac{16}{38}$

6. $\frac{20}{36} \stackrel{?}{=} \frac{50}{90}$

7. $\frac{20}{28} \stackrel{?}{=} \frac{28}{36}$

8. $\frac{14}{42} \stackrel{?}{=} \frac{16}{36}$

Solve each proportion.

9. $\frac{\$d}{3 \text{ CDs}} = \frac{\$64.75}{5 \text{ CDs}}$

10. $\frac{c \text{ chairs}}{7 \text{ rows}} = \frac{252 \text{ chairs}}{9 \text{ rows}}$

11. $\frac{m \text{ miles}}{5 \text{ hours}} = \frac{135 \text{ miles}}{3 \text{ hours}}$

12. $\frac{\$d}{4 \text{ subs}} = \frac{\$45}{10 \text{ subs}}$

Solve each proportional situation using equivalent fractions.

13. $\frac{c}{15} = \frac{4}{10}$

14. $\frac{a}{6} = \frac{8}{12}$

15. $\frac{b}{20} = \frac{15}{12}$

16. $\frac{w}{6} = \frac{15}{10}$

17. Janessa bought 4 stamps for \$1.48. At this rate, how much would 10 stamps cost?

18. A karate team had 6 girls and 9 boys. Then 2 more girls and 3 more boys joined the team. Did the ratio of girls to boys stay the same? Explain.

19. A 30 kg weight is positioned 2 m from a fulcrum. At what distance from the fulcrum must a 40 kg weight be positioned to keep the scale balanced?

LESSON **Practice**
5-5 **Similar Figures**

1. Are any of these triangles similar?

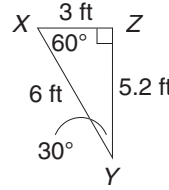
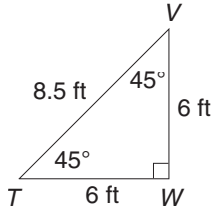
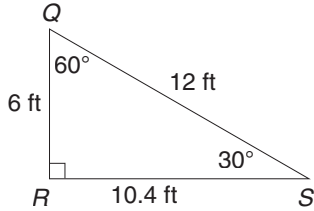

2. A photo is 12 in. wide by 18 in. tall. If the width is scaled down to 9 inches, how tall should the similar photo be?

3. An isosceles triangle has a base of 20 cm and legs measuring 36 cm. How long are the legs of a similar triangle with base measuring 50 cm?

4. A picture of a school's mascot is 18 in. wide and 24 in. long. It is enlarged proportionally to banner size. If the width is enlarged to 63 in., what is the length of the banner?

5. Carol has a 24 cm × 36 cm photo that she reduces to $\frac{3}{4}$ of its size. What are the dimensions of the new photo?

6. Erik is drawing a picture of his school's basketball court. The actual basketball court is 84 ft long and 50 ft wide. If Erik draws the court with a length of 21 in., what will be the width?

7. IMAX theaters have the world's largest screens. There are numerous IMAX theaters around the world. The Henry Ford Museum in Dearborn, Michigan hosts an IMAX theater with a 60 ft × 84 ft screen. If a classroom projection screen were changed to be in direct proportion with the IMAX screen at the Henry Ford Museum, the dimensions would be 5 ft × ____ ft.

LESSON Practice
5-6 Dilations

Tell whether each transformation is a dilation.

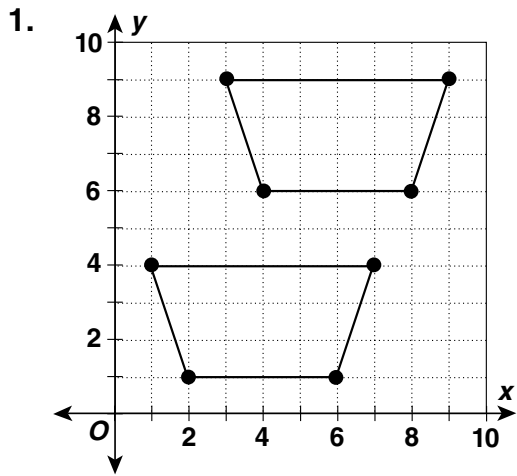

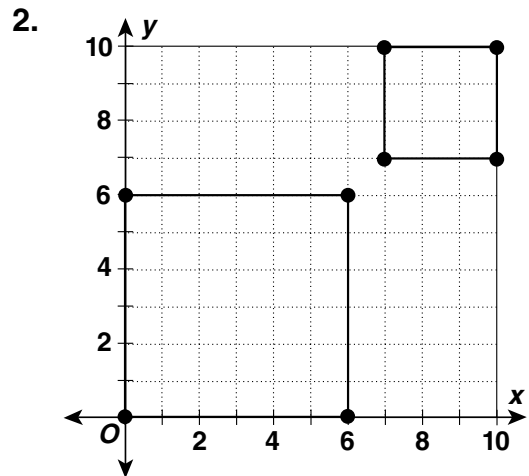

Dilate each figure by the given scale factor with the origin as the center of dilation. What are the vertices of the image?

3. scale factor of 2

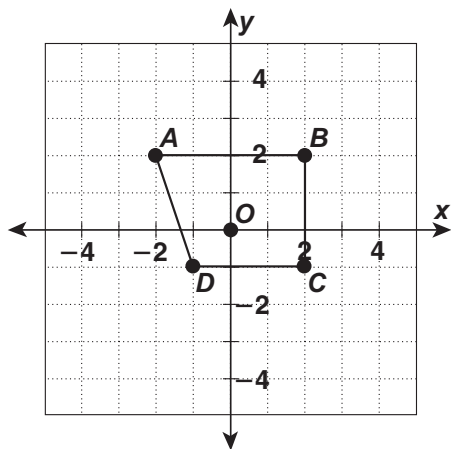

4. scale factor of $\frac{1}{2}$

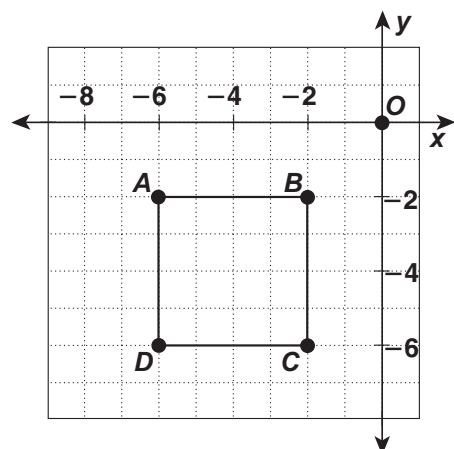

LESSON **Practice**
5-7 *Indirect Measurement*

1. Tamara wants to know the width of the pond at the park. She drew the diagram and labeled it with the measurements she made. How wide is the pond?

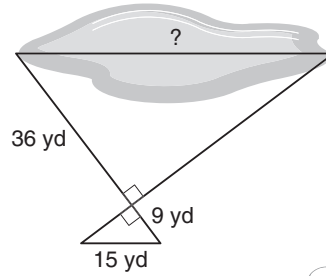

Use the diagram for 2 and 3.

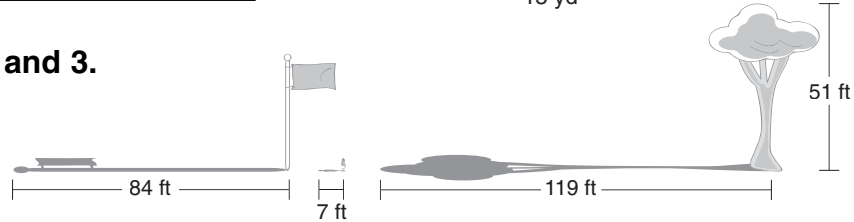

2. How tall is the flagpole?

3. How tall is the child?

Use the diagram for 4 and 5.

4. How tall is the house?

5. The tree is 56 feet tall. How long is its shadow?

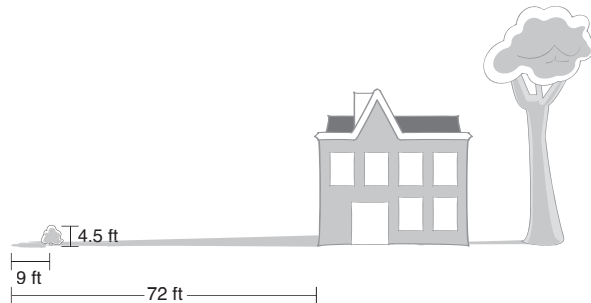

6. Drew wants to know the distance across the river. He drew the diagram and labeled it with the measurements he made. What is the distance across the river?

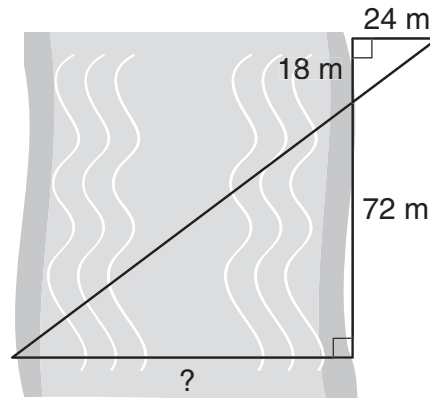

7. A warehouse is 120 feet tall and casts a shadow 288 feet long. At the same time, Julie casts a shadow 12 feet long. How tall is Julie?

LESSON
5-8 **Practice**
Scale Drawings and Scale Models

The scale of a drawing is $\frac{1}{4}$ in. = 15 ft. Find the actual measurement.

1. 9 in.

2. 12 in.

3. 14 in.

4. 15 in.

The scale is 2 cm = 25 m. Find the length each measurement would be on a scale drawing.

5. 150 m

6. 475 m

7. 350 m

8. 500 m

Tell whether each scale reduces, enlarges, or preserves the size of an actual object.

9. 1 m : 25 cm

10. 8 in. : 1 ft

11. 12 in. : 1 ft

12. On a map the distance between Atlanta, Georgia, and Nashville, Tennessee, is 12.5 in. The actual distance between these two cities is 250 miles. What is the scale?

13. Blueprints of a house are drawn to the scale of $\frac{1}{4}$ in. = 1 ft. A kitchen measures 3.5 in. by 5 in. on the blueprints. What is the actual size of the kitchen?

14. A scale model of a house is 1 ft long. The actual house is 50 ft long. In the model, the window is $1\frac{1}{5}$ in. high. How many feet high is the actual window?

15. A model of a skyscraper is 1.6 in. long, 2.8 in. wide, and 11.2 in. high. The scale factor is 8 in. : 250 ft. What are the actual dimensions of the skyscraper?

LESSON **Practice**
6-1 *Relating Decimals, Fractions, and Percents*

Find the missing ratio or percent equivalent for each letter on the number line.

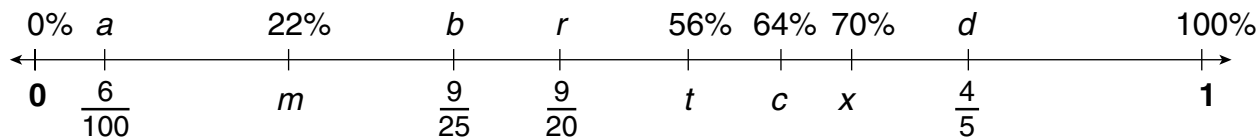

1. a _____ 2. b _____ 3. c _____ 4. d _____

5. m _____ 6. r _____ 7. t _____ 8. x _____

Compare. Write $<$, $>$, or $=$.

9. $\frac{3}{4}$ 70% 10. 60% $\frac{3}{5}$ 11. 58% 0.6
12. 0.09 15% 13. $\frac{2}{3}$ 59% 14. 0.45 40.5%

Order the numbers from least to greatest.

15. 99%, 0.95, $\frac{5}{9}$, 9.5% 16. $\frac{3}{8}$, 50%, 0.35, 38%
- _____
17. $\frac{4}{5}$, 54%, 0.45, 44.5% 18. $\frac{1}{3}$, 20%, 0.3, 3%
- _____

19. There are 25 students in math class. Yesterday, 6 students were absent. What percent of the students were absent? _____
20. Albert spends 2 hours a day on his homework and an hour playing video games. What percent of the day is this? _____
21. Ragu ran the first 3 miles of a 5 mile race in 24 minutes. What percent of the race has he run? _____

LESSON **Practice**
6-2 *Estimate with Percents*

Estimate.

1. 74% of 99

2. 25% of 39

3. 52% of 10

4. 21% of 50

5. 30% of 61

6. 24% of 48

7. 5% of 41

8. 50% of 178

9. 33% out of 62

Estimate.

10. 48% of 30 is about what number?

11. 26% of 36 is about what number?

12. 30% of 22 is about what number?

13. 21% of 63 is about what number?

14. Rodney's weekly gross pay is \$91. He must pay about 32% in taxes and deductions. Estimate Rodney's weekly take-home pay after deductions.

15. In the last school election, 492 students voted. Mary received 48% of the votes. About how many votes did she receive?

16. A restaurant bill for lunch is \$14.10. Grace wants to leave a 15% tip and the sales tax rate is 5.5%. About how much will lunch cost Grace in all?

17. A company has found that on average about 6% of the batteries they manufacture are defective. Out of 1,385 batteries, the supervisor assumes that about 83 are defective. Estimate to determine if the manager's number is reasonable? Explain.

LESSON
6-3 **Practice**
Finding Percents

Find each percent.

1. What percent of 84 is 21?

2. 24 is what percent of 60?

3. What percent of 150 is 75?

4. What percent of 80 is 68?

5. 36 is what percent of 80?

6. What percent of 88 is 33?

7. 19 is what percent of 95?

8. 28.8 is what percent of 120?

9. What percent of 56 is 49?

10. What percent of 102 is 17?

11. What percent of 94 is 42.3?

12. 90 is what percent of 75?

13. Daphne bought a used car for \$9200. She made a down payment of \$1840. Find the percent of the purchase price that is the down payment. _____
14. Tricia read $\frac{1}{4}$ of her book on Monday. On Tuesday, she read 36% of the book. On Wednesday, she read 0.27 of the book. She finished the book on Thursday. What percent of the book did she read on Thursday? _____
15. An airplane traveled from Boston to Las Vegas making a stop in St. Louis. The plane traveled 2410 miles altogether, which is 230% of the distance from Boston to St. Louis. Find the distance from Boston to St. Louis to the nearest mile. _____
16. The first social studies test had 16 questions. The second test had 220% as many questions as the first test. Find the number of questions on the second test. _____

LESSON Practice**6-4 Finding a Number When the Percent Is Known****Find each number to the nearest tenth.**

1. 40% of what number is 18?

 2. 28 is 35% of what number?

 3. 21 is 60% of what number?

 4. 25% of what number is 19?

 5. 40% of what number is 22?

 6. 41 is 50% of what number?

 7. 50 is 15% of what number?

 8. 0.3% of what number is 24?

 9. 36 is 30% of what number?

 10. 26 is 75% of what number?

 11. 12.5% of what number is 14?

 12. 25% of what number is 28.25?

 13. 27 is $33\frac{1}{3}\%$ of what number?

 14. 54 is 150% of what number?

15. There were 546 students at a school assembly. This was 65% of all students who attend Content Middle School. How many students attend Content Middle School?

16. On his last test Greg answered 64 questions correctly. This was 80% of the questions. How many questions were on the test?

17. The price of a jacket is \$48. If the sales tax rate is 5.5%, what is the amount of tax? What is the total cost of the jacket?

18. Carla has finished swimming 14 laps in swim practice. This is 70% of the total number of laps she must swim. How many more laps must Carla swim to complete her practice?

LESSON **Practice**
6-5 *Percent Increase and Decrease*

Find each percent increase or decrease to the nearest percent.

1. from 16 to 20

2. from 30 to 24

3. from 15 to 30

4. from 35 to 21

5. from 40 to 46

6. from 45 to 63

7. from 18 to 26.1

8. from 24.5 to 21.56

9. from 90 to 72

10. from 29 to 54

11. from 42 to 92.4

12. from 38 to 33

13. from 64 to 36.4

14. from 78 to 136.5

15. from 89 to 32.9

16. Mr. Havel bought a car for \$2400 and sold it for \$2700.
 What was the percent of profit for Mr. Havel in selling the car? _____

17. A computer store buys a computer program for \$24 and
 sells it for \$91.20. What is the percent of increase in the
 price? _____

18. A manufacturing company with 450 employees begins
 a new product line and must add 81 more employees.
 What is the percent of increase in the number of employees? _____

19. Richard earns \$2700 a month. He received a 3% raise.
 What is Richard's new annual salary? _____

20. Marlis has 765 cards in her baseball card collection.
 She sells 153 of the cards. What is the percent of
 decrease in the number of cards in the collection? _____

LESSON
6-6 **Practice**
Applications of Percents

Complete the table to find the amount of sales tax for each sale amount to the nearest cent.

1.

Sale amount	5% sales tax	8% sales tax	6.5% sales tax
\$67.50			
\$98.75			
\$399.79			
\$1250.00			

Complete the table to find the commission for each sale amount to the nearest cent.

2.

Sale amount	6% commision	9% commision	8.5% commission
\$475.00			
\$2450.00			
\$12,500.00			
\$98,900.00			

3. Alice earns a monthly salary of \$315 plus a commission on her total sales. Last month her total sales were \$9640, and she earned a total of \$1182.60. What is her commission rate? _____

4. Phillipe works for a computer store that pays a 12% commission and no salary. What will Phillipe's weekly sales have to be for him to earn \$360? _____

5. The purchase price of a book is \$35.85. The sales tax rate is 6.5%. How much is the sales tax to the nearest cent? What is the total cost of the book?

6. Who made more commission this month? How much did she make? Salesperson A made 11% of \$67,530. Salesperson B made 8% of \$85,740.

7. Jon earned \$38,000 last year. He paid \$6,840 towards entertainment. What percent of his earnings did Jon pay in entertainment expenses? _____

8. The Cougars won 62% of their games. They won 93 games. How many games did they lose? _____

LESSON **Practice**
6-7 *More Applications of Percents*

Find the missing value.

1. principal = \$125
 rate = 4%
 time = 2 years
 interest = ?

2. principal = ?
 rate = 5%
 time = 4 years
 interest = \$90

3. principal = \$150
 rate = 6%
 time = ? years
 interest = \$54

4. principal = \$200
 rate = ?%
 time = 3 years
 interest = \$30

5. principal = \$550
 rate = ?%
 time = 3 years
 interest = \$57.75

6. principal = ?
 rate = $3\frac{1}{4}\%$
 time = 2 years
 interest = \$63.05

7. Kwang deposits money in an account that earns 5% simple interest. He earned \$546 in interest 2 years later. How much did he deposit? _____

8. Simon opened a certificate of deposit with the money from his bonus check. The bank offered 4.5% interest for 3 years of deposit. Simon calculated that he would earn \$87.75 interest in that time. How much did Simon deposit to open the account? _____

9. Douglas borrowed \$1000 from Patricia. He agreed to repay her \$1150 after 3 years. What was the interest rate of the loan? _____

10. What is the interest paid for a loan of \$800 at 5% annual interest for 9 months? _____

LESSON **Practice**
7-1 *Points, Lines, Planes, and Angles*

Use the diagram to name each figure.

1. four points

2. a line

3. a plane

4. three segments

5. four rays

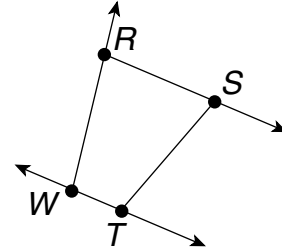

Use the diagram to name each figure.

6. a right angle

7. two acute angles

8. two obtuse angles

9. a pair of complementary angles

10. three pairs of supplementary angles

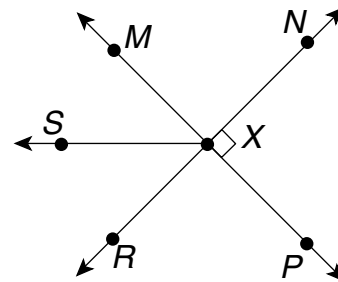

In the figure, $\angle 1$ and $\angle 3$ are vertical angles, and $\angle 2$ and $\angle 4$ are vertical angles.

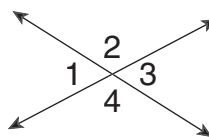

11. If $m\angle 2 = 110^\circ$, find $m\angle 4$.

12. If $m\angle 1 = n^\circ$, find $m\angle 3$.

LESSON **Practice**
7-2 **Parallel and Perpendicular Lines**

1. Measure the angles formed by the transversal and the parallel lines. Which angles seem to be congruent?

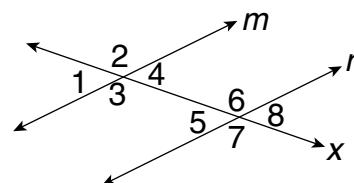

In the figure, line $m \parallel$ line n . Find the measure of each angle.

2. $\angle 1$ 3. $\angle 2$ 4. $\angle 5$

5. $\angle 6$ 6. $\angle 8$ 7. $\angle 7$

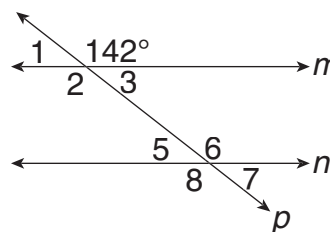

In the figure, line $a \parallel$ line b . Find the measure of each angle.

8. $\angle 2$ 9. $\angle 5$ 10. $\angle 6$

11. $\angle 7$ 12. $\angle 4$ 13. $\angle 3$

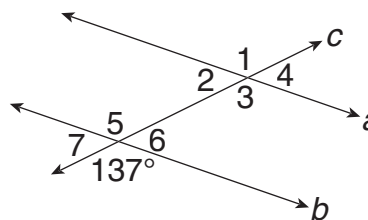

In the figure, line $r \parallel$ line s .

14. Name all angles congruent to $\angle 2$.

15. Name all angles congruent to $\angle 7$.

16. Name three pairs of supplementary angles.

17. Which line is the transversal?

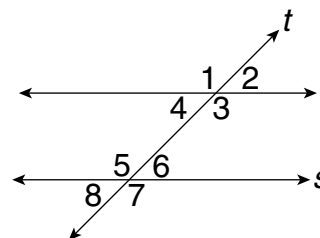

LESSON
7-3 **Practice**
Angles in Triangles

1. Find x° in the right triangle.

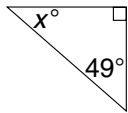

2. Find y° in the obtuse triangle.

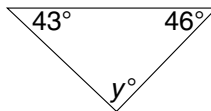

3. Find m° in the acute triangle.

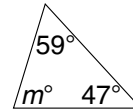

4. Find n° in the obtuse triangle.

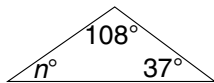

5. Find w° in the acute triangle.

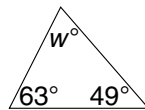

6. Find t° in the right triangle.

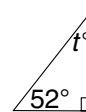

7. Find t° in the scalene triangle.

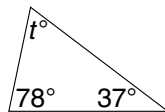

8. Find x° in the isosceles triangle.



9. Find n° in the scalene triangle.



10. Find x° in the isosceles triangle.

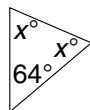

11. Find y in the equilateral triangle.

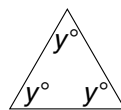

12. Find r in the isosceles triangle.

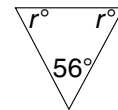

13. The second angle in a triangle is one third as large as the first. The third angle is two thirds as large as the first angle. Find the angle measures. Draw a possible picture of the triangle.

LESSON **Practice**
7-4 **Classifying Polygons**

Find the sum of the angle measures in each figure.

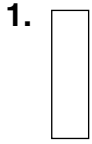

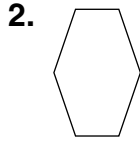

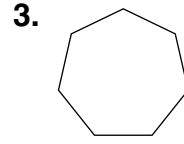

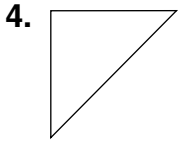

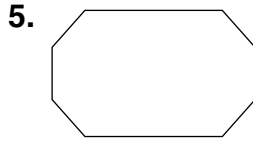

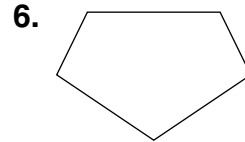

Find the angle measures in each regular polygon.

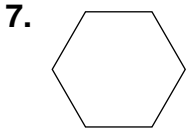

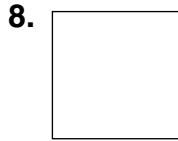

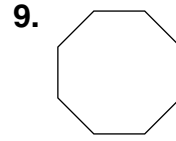

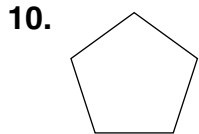

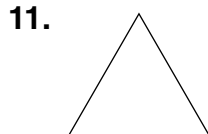

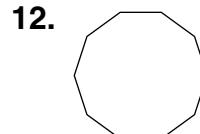

Give all the names that apply to each figure.

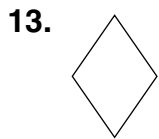

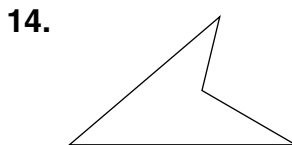

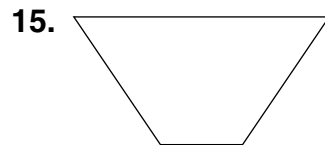

LESSON **Practice**
7-5 **Coordinate Geometry**

Determine if the slope of each line is positive, negative, 0, or undefined. Then find the slope of each line.

1. \overleftrightarrow{AB}

2. \overleftrightarrow{CD}

3. \overleftrightarrow{RS}

4. \overleftrightarrow{TC}

5. \overleftrightarrow{DR}

6. \overleftrightarrow{TX}

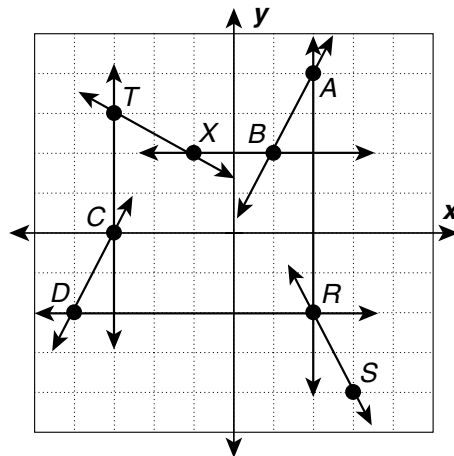

7. Which lines are parallel?

8. Which lines are perpendicular?

Graph the quadrilateral with the given vertices. Write all the names that apply to the quadrilateral.

9. $(-1, 1)$, $(4, 1)$, $(1, -3)$, $(-4, -3)$

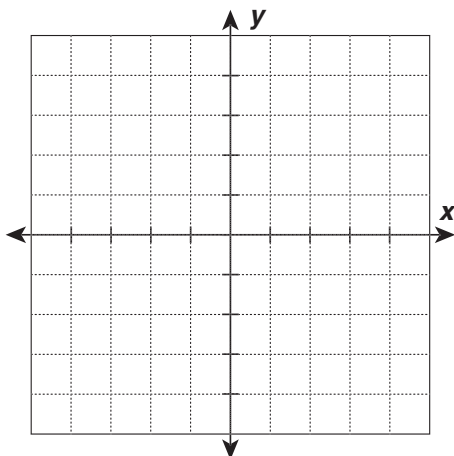

Find the coordinates of the missing vertex.

10. rhombus $ABCD$ with $A(0, 4)$, $B(4, 1)$, and $C(0, -2)$

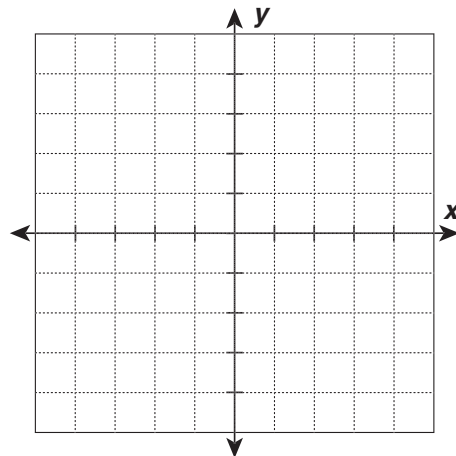

LESSON **Practice**
7-6 **Congruence**

Write a congruence statement for each pair of polygons.

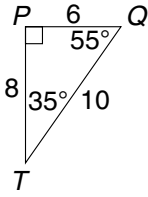
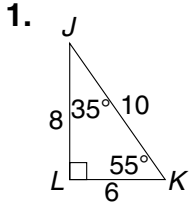

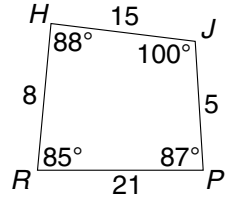
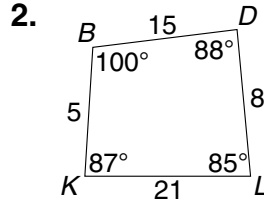

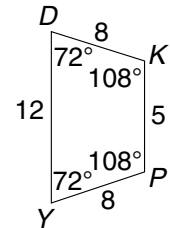
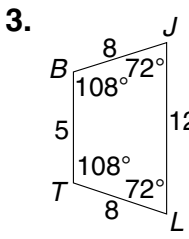

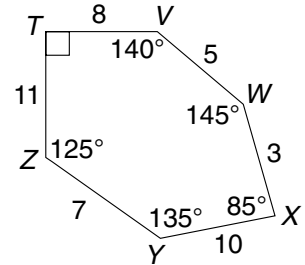
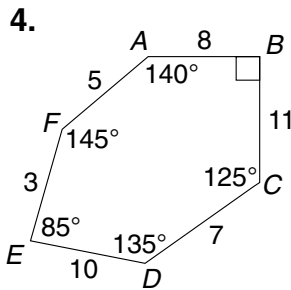

In the figure, triangle $PRT \cong$ triangle FJH .

5. Find a .

6. Find b .

7. Find c .

8. Find x .

9. Find y .

10. Find z .

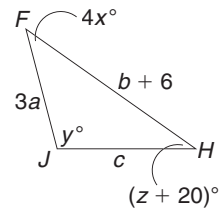
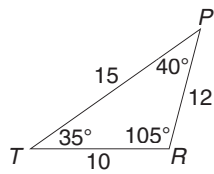

LESSON **Practice**
7-7 **Transformations**

Identify each as a translation, rotation, reflection, or none of these.

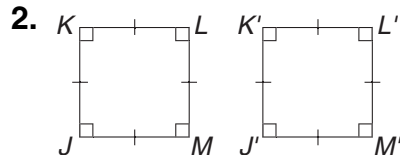
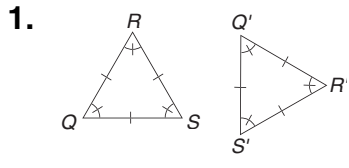

Draw the image of the rectangle $ABCD$ with vertices $(-2, 1)$, $(-1, 3)$, and $(3, 3)$, $(2, 1)$ after each transformation.

3. translation 3 units down

4. 180° rotation around $(0, 0)$

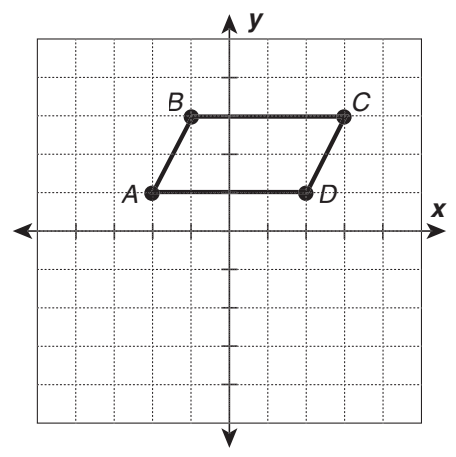
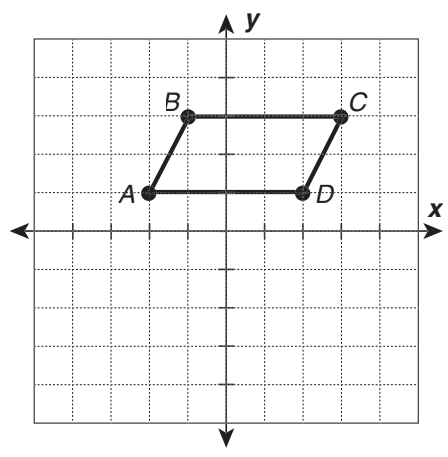

Triangle ABC has vertices $A(-3, 1)$, $B(2, 4)$, and $C(3, 1)$. Find the coordinates of the image of each point after each transformation.

5. reflection across the x -axis, point B

6. translation 6 units down, point A

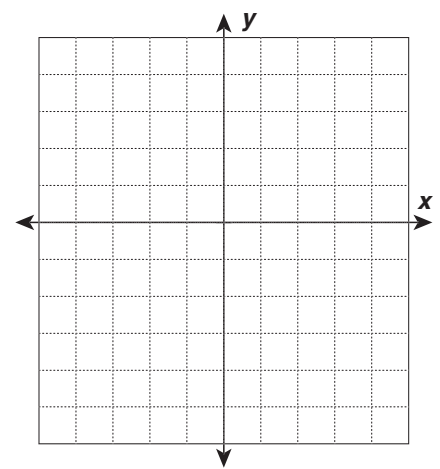
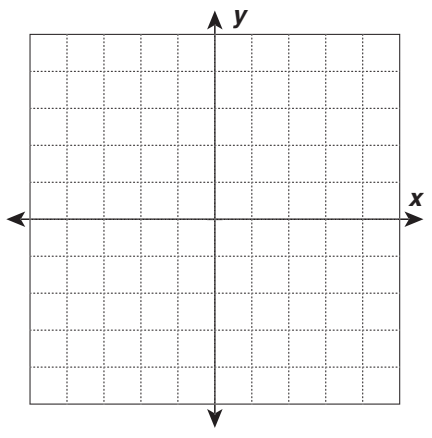

LESSON

7-8

Practice

Symmetry

Complete each figure. The dashed line is the line of symmetry.

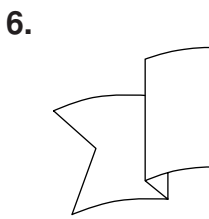
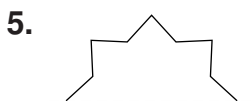
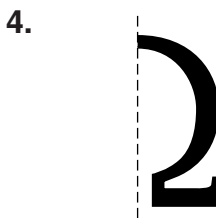
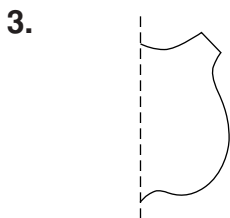

Complete each figure. The point is the center of rotation.

7. 5-fold



8. 4-fold



9. 2-fold



10. 2-fold

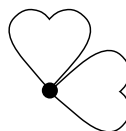

LESSON
7-9 **Practice**
Tessellations

1. Create a tessellation with quadrilateral $ABCD$.

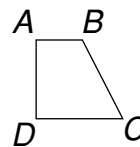

2. Use rotations to create a variation of the tessellation in Exercise 1.

3. Create a tessellation with hexagon $ABCDEF$.

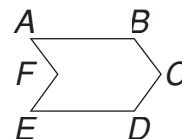

4. Use rotations to create a variation of the tessellation in Exercise 3.

LESSON **Practice**
8-1 *Perimeter and Area of Rectangles and Parallelograms*

Find the perimeter of each figure.

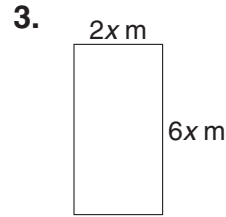
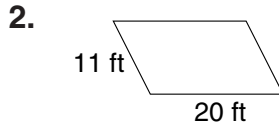
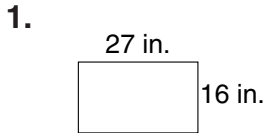

Graph and find the area of each figure with the given vertices.

4. $(-3, 4), (3, 4), (3, -4), (-3, -4)$

5. $(-1, 3), (2, 3), (-1, -4), (-4, -4)$

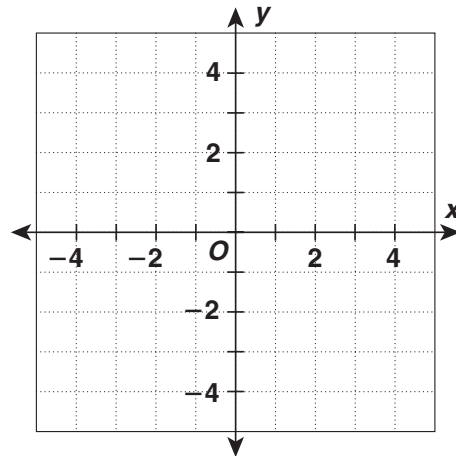
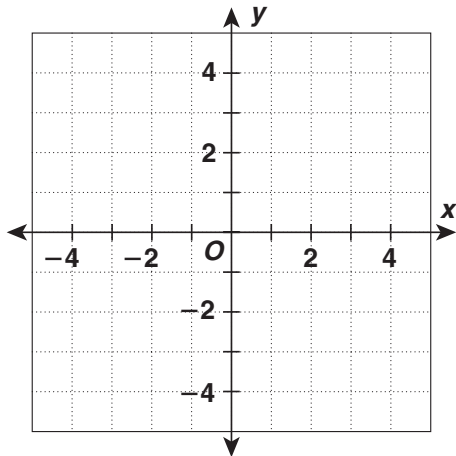

6. Sloppi and Sons Painting Co. charges its customers \$1.50 per square foot. How much would Sloppi and Sons charge to paint the rooms of this house if the walls in each room are 9 ft high?

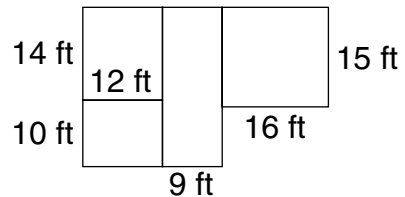

LESSON **Practice**
8-2 **Perimeter and Area of Triangles and Trapezoids**

Find the perimeter of each figure.

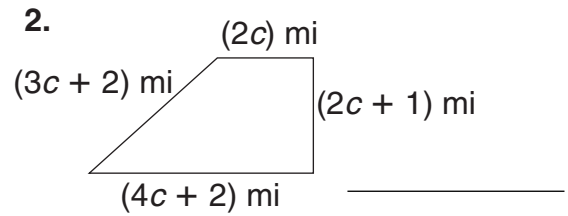
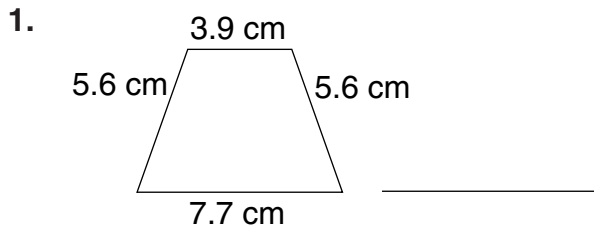

Find the missing measurement for each figure with the given perimeter.

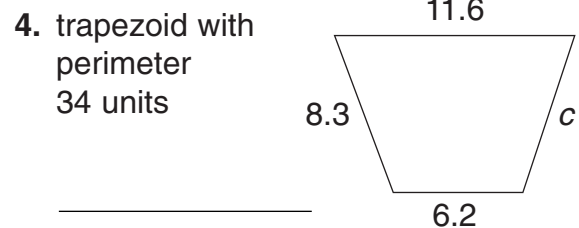
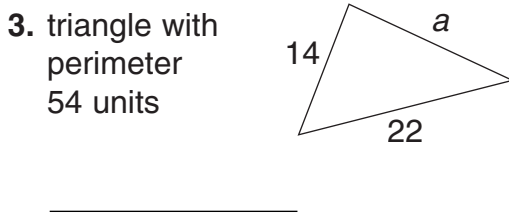

Graph and find the area of each figure with the given vertices.

5. $(-1, 3), (4, 3), (4, -4), (-4, -4)$

6. $(-1, 2), (-4, -2), (4, -2)$

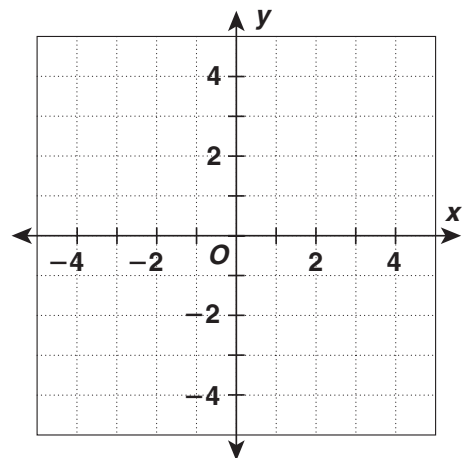
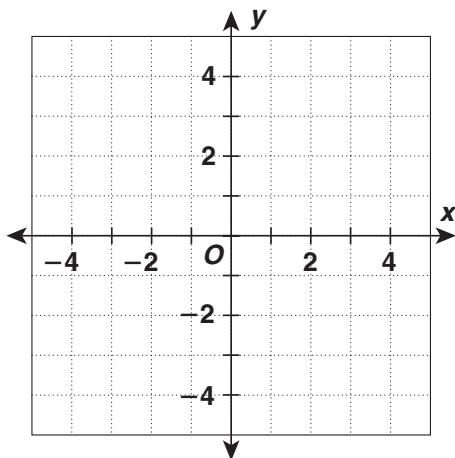

7. The two shortest sides of a pennant shaped like a right triangle measure 10 inches and 24 inches. Hank wants to put colored tape around the edge of the pennant. How many inches of tape does he need?

LESSON
8-3 **Practice**
Circles

Find the circumference of each circle, both in terms of π and to the nearest tenth. Use 3.14 for π .

1. circle with radius 10 in.

2. circle with diameter 13 cm

3. circle with diameter 18 m

4. circle with radius 15 ft

5. circle with radius 11.5 in.

6. circle with diameter 16.4 cm

Find the area of each circle, both in terms of π and to the nearest tenth. Use 3.14 for π .

7. circle with radius 9 in.

8. circle with diameter 14 cm

9. circle with radius 20 ft

10. circle with diameter 17 m

11. circle with diameter 15.4 m

12. circle with radius 22 yd

13. Graph a circle with center $(0, 0)$ that passes through $(0, -3)$. Find the area and circumference, both in terms of π and to the nearest tenth. Use 3.14 for π .

14. A wheel has a radius of $2\frac{1}{3}$ feet. About how far does it travel if it makes 60 complete revolutions? Use $\frac{22}{7}$ for π .

LESSON **Practice**
8-4 **Drawing Three-Dimensional Figures**

1. Name the vertices, edges, and faces of the three-dimensional figure shown.

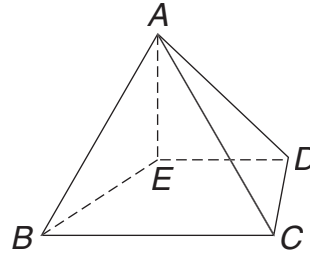

edges: _____

faces: _____

2. Draw the figure that has the following top, front, and side views.

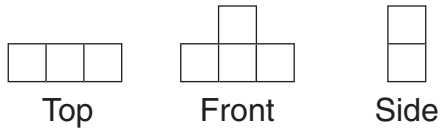

3. Draw the front, top, and side views of the figure.

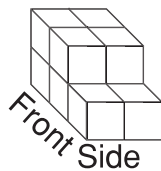

LESSON **Practice**
8-5 **Volume of Prisms and Cylinders**

Find the volume of each figure to the nearest tenth. Use 3.14 for π .

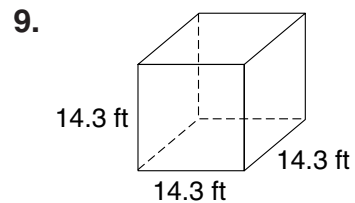
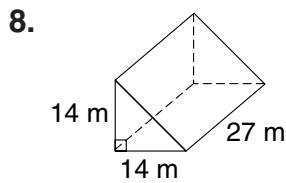
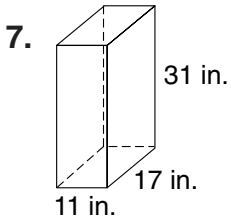
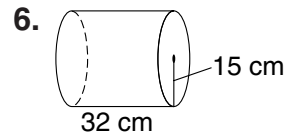
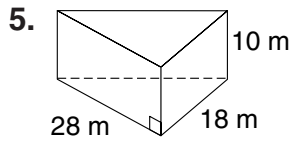
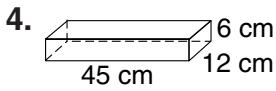
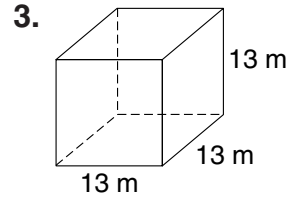
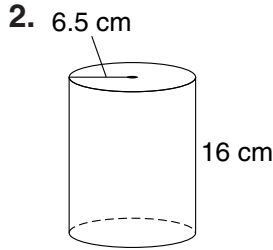
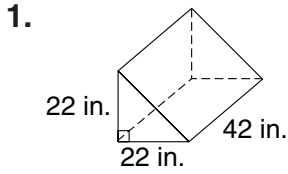

10. A cylinder has a radius of 6 ft and a height of 25 ft. Explain whether tripling the height will triple the volume of the cylinder.

11. Contemporary American building bricks are rectangular blocks with the standard dimensions of about 5.7 cm by 9.5 cm by 20.3 cm. What is the volume of a brick to the nearest tenth of a unit?

12. Ian is making candles. His cylindrical mold is 8 in. tall and has a base with a diameter of 3 in. Find the volume of a finished candle to the nearest tenth of a unit.

LESSON **Practice**
8-6 **Volume of Pyramids and Cones**

Find the volume of each figure to the nearest tenth. Use 3.14 for π .

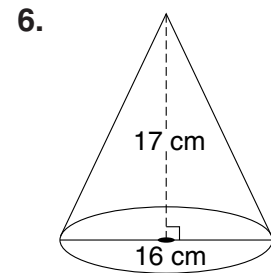
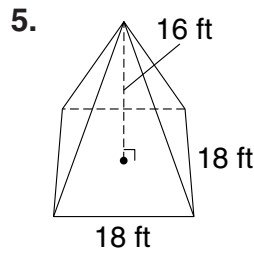
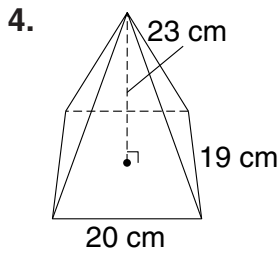
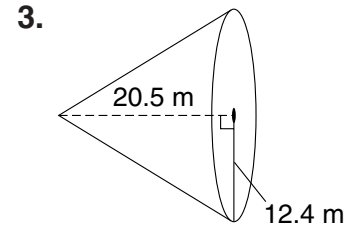
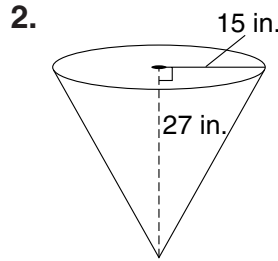
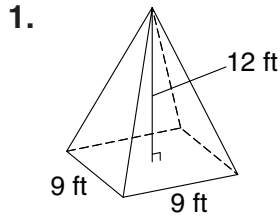

7. The base of a regular pyramid has an area of 28 in^2 . The height of the pyramid is 15 in. Find the volume.

8. The radius of a cone is 19.4 cm and its height is 24 cm. Find the volume of the cone to the nearest tenth.

9. Find the volume of a rectangular pyramid if the height is 13 m and the base sides are 12 m and 15 m.

10. A funnel has a diameter of 9 in. and is 16 in. deep. Use a calculator to find the volume of the funnel to the nearest hundredth.

11. A square pyramid has a height 18 cm and a base that measures 12 cm on each side. Explain whether tripling the height would triple the volume of the pyramid.

LESSON **Practice**
8-7 **Surface Area of Prisms and Cylinders**

Find the surface area of each figure to the nearest tenth. Use 3.14 for π .

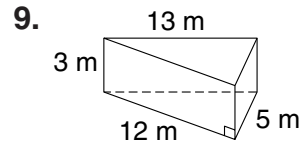
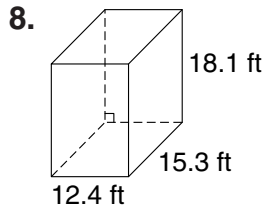
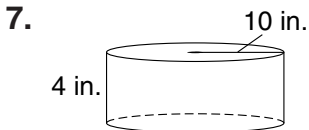
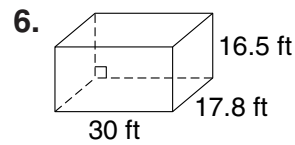
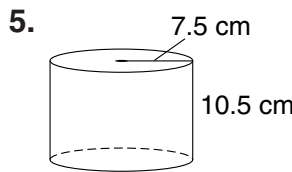
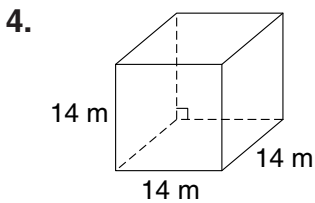
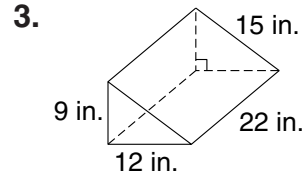
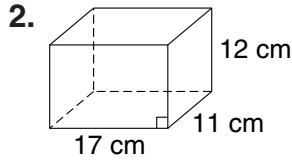
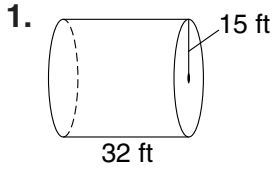

10. Find the surface area to the nearest tenth of a rectangular prism with height 15 m and sides 14 m and 13 m. _____

11. Find the surface area to the nearest tenth of a cylinder 61.7 ft tall that has a diameter of 38 ft. _____

12. Henry wants to paint the ceiling and walls of his living room. One gallon of paint covers 450 ft^2 . The room is 24 ft by 18 ft, and the walls are 9 ft high. How many full gallons of paint will Henry need to paint his living room? _____

13. A rectangular prism is 18 in. by 16 in. by 10 in. Explain the effect, if any, tripling all the dimensions will have on the surface area of the figure.

LESSON **Practice**
8-8 **Surface Area of Pyramids and Cones**

Find the surface area of each figure to the nearest tenth.
 Use 3.14 for π .

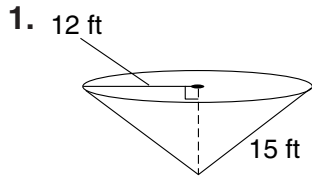

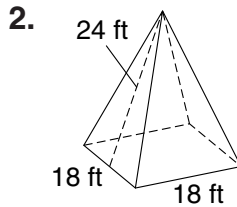

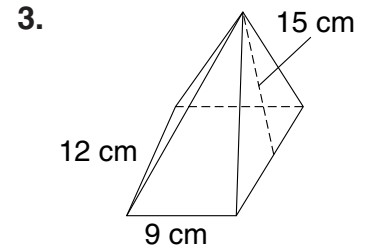

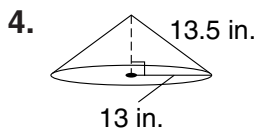

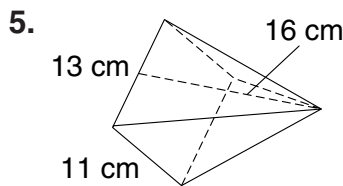

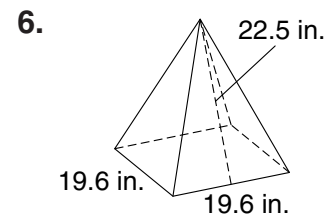

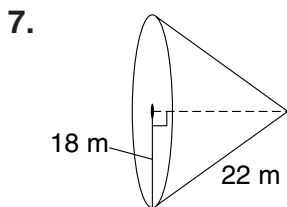

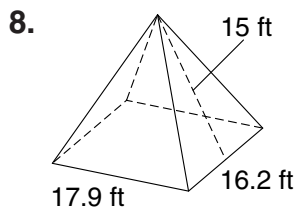

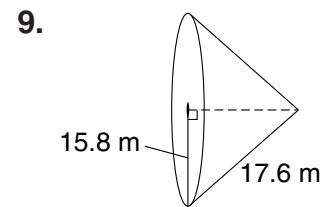

10. Find the surface area of a regular square pyramid with a slant height of 17 m and a base perimeter of 44 m. _____

11. Find the length of the slant height of a square pyramid if one side of the base is 15 ft and the surface area is 765 ft^2 . _____

12. Find the length of the slant height of a cone with a radius of 15 cm and a surface area of 1884 cm^2 . _____

13. A cone has a diameter of 12 ft and a slant height of 20 ft. Explain whether tripling both dimensions would triple the surface area.

LESSON **Practice**
8-9 **Spheres**

Find the volume of each sphere, both in terms of π and to the nearest tenth. Use 3.14 for π .

1. $r = 9$ ft.

2. $r = 21$ m

3. $d = 30$ cm

4. $d = 24$ cm

5. $r = 15.4$ in.

6. $r = 16.01$ ft

Find the surface area of each sphere, both in terms of π and to the nearest tenth. Use 3.14 for π .

7.

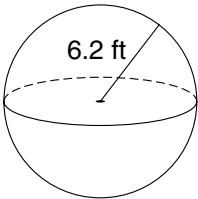

8.

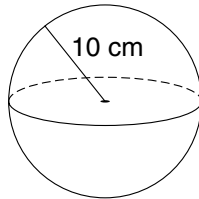

9.

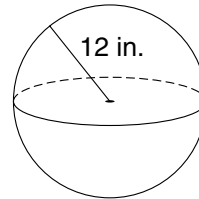

10.

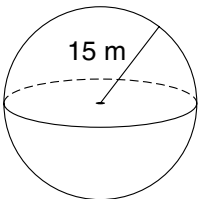

11.

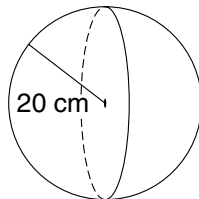

12.

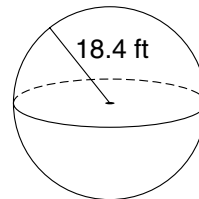

13. In the sport of track and field, a field event is the shot put. This is a game in which a heavy ball or shot is thrown or put for distance. The shot itself comes in various sizes, weights and composition. Find the volume and surface area of a shot with diameter 5.5 cm both in terms of π and to the nearest tenth.

LESSON
8-10 **Practice**
Scaling Three-Dimensional Figures

**A 10 in. cube is built from small cubes, each 2 in. on a side.
Compare the following values.**

1. The side lengths of the two cubes

2. The surface area of the two cubes

3. The volumes of the two cubes

**A 9 cm cube is built from small cubes, each 3 cm on a side.
Compare the following values.**

4. The side lengths of the two cubes

5. The surface area of the two cubes

6. The volumes of the two cubes

7. The dimensions of a warehouse are 120 ft long, 180 ft wide, and 60 ft high. The scale model used to build the warehouse is 20 in. long. Find the width and height of the model of the warehouse.

8. It takes a machine 40 seconds to fill a cubic box with sides measuring 10 in. How long will it take the same machine to fill a cubic box with sides measuring 15 in.?

LESSON
9-1 **Practice**
Samples and Surveys

Identify the sampling method used.

1. People in the security line at the airport are asked to step out of the line for a more detailed search. The people pulled out of the line have not necessarily done anything wrong, and they are not chosen according to any particular rule.

2. At the 1-mile marker of a marathon, a timekeeper shouts out the time elapsed to every 10th runner that passes by. A statistician records the times shouted.

3. A geologist visits 10 randomly-selected lakes in the region and collects soil samples in randomly-selected areas along each shoreline.

Identify the population and sample. Give a reason the sample could be biased.

4. At a convention of science teachers, various attendees are asked to name their favorite subject in high school.

population _____

sample _____

possible bias _____

5. Donors participating in a blood drive are given a small amount of money for their blood donation. Before they can give blood, each person is surveyed to find out if they are eligible to give blood.

population _____

sample _____

possible bias _____

6. Interviewers at the mall are surveying girls with red hair to find out if a correlation exists between personality and red hair.

population _____

sample _____

possible bias _____

LESSON
9-2 **Practice**
Organizing Data

1. Use a line plot to organize the data of **Distances Students Travel to School (mi)**
the distances students travel to school. 2 8 6 10 5 4 6 8 3 2
11 5 1 3 6 5 7 5 2 4

List the data values in the stem-and-leaf plot.

2. 2 | 0 1 5 7
3 | 2 2 9
4 | 5 6 7 9
5 | 1 3 Key: 5 | 1 = 51

3. Use the given data to make a back-to-back stem-and-leaf plot.

NBA Midwest Division 2000–2001 Final Standings

NBA Team	Wins	Losses	NBA Team	Wins	Losses
San Antonio Spurs	58	24	Houston Rockets	45	37
Utah Jazz	53	29	Denver Nuggets	40	42
Dallas Mavericks	53	29	Vancouver Grizzlies	23	59
Minnesota Timberwolves	47	35			

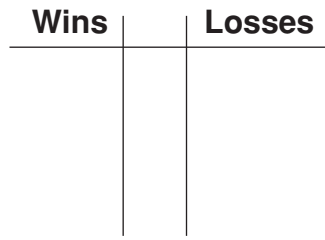

Key:

4. Make a Venn diagram to show how many girls in an eighth-grade class belonged to both a team and a club.

Team	yes	no	yes	no	yes	yes	yes	no	no	yes	no	no
Club	yes	yes	no	yes	yes	no	yes	yes	yes	no	no	yes

LESSON

9-3

Practice

Measures of Central Tendency

Find the mean, median, mode, and range of each data set.

1. 7, 7, 4, 9, 6, 4, 5, 8, 4

mean: _____

median: _____

mode: _____

range: _____

2. 1.2, 5.8, 3.7, 9.7, 5.5, 0.3, 8.1

mean: _____

median: _____

mode: _____

range: _____

3. 31, 28, 31, 30, 31, 30, 31, 31, 30, 31, 30, 31

mean: _____

median: _____

mode: _____

range: _____

4. 65, 46, 78, 3, 87, 12, 99, 38, 71, 38

mean: _____

median: _____

mode: _____

range: _____

Determine and find the most appropriate measure of central tendency or range for each situation. Refer to the table at the right for Exercises 5–7.

5. Which measure best describes the middle of the data?

6. Which earthquake magnitude occurred most frequently?

7. How spread out are the data?

Some Major Earthquakes in United States History

Year	Location	Magnitude
1812	Missouri	7.9
1872	California	7.8
1906	California	7.7
1957	Alaska	8.8
1964	Alaska	9.2
1965	Alaska	8.7
1983	Idaho	7.3
1986	Alaska	8.0
1987	Alaska	7.9
1992	California	7.6

8. Nicole purchased gasoline 8 times in the last two months. The prices that she paid per gallon each time were \$2.19, \$2.14, \$2.28, \$2.09, \$2.01, \$1.99, \$2.19, and \$2.39. Which measure makes the prices appear lowest?

LESSON
9-4 **Practice**
Variability

Find the first and third quartiles for each data set.

1. 37, 48, 56, 35, 53, 41, 50

first quartile: _____

third quartile: _____

2. 18, 20, 34, 33, 16, 44, 42, 27

first quartile: _____

third quartile: _____

Use the given data to make a box-and-whisker plot.

3. 55, 46, 70, 36, 43, 45, 52, 61

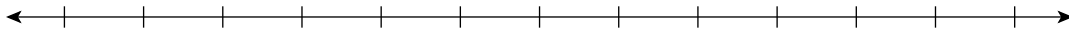

4. 23, 34, 31, 16, 38, 42, 45, 30, 28, 25, 19, 32, 53

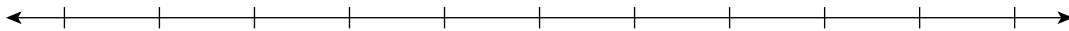

Use the box-and-whisker plots to compare the data sets.

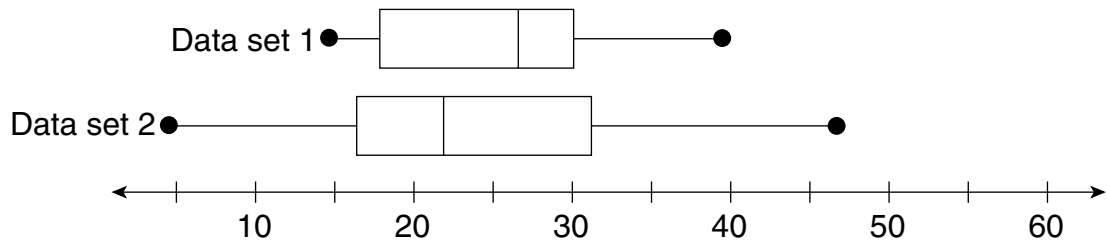

5. Compare the medians and ranges.

6. Compare the ranges of the middle half of the data for each set.

LESSON

9-5

Practice

Displaying Data

1. Make a double-bar graph.

Daily Hours Worked	6	7	8	9	10	11	12
Crew A	4	3	6	1	3	1	2
Crew B	5	5	4	3	2	0	1



2. Use the data to make a histogram with intervals of 5.

Weekly Allowance of 20 Students			
\$5	\$15	\$2	\$10
\$12	\$12	\$10	\$15
\$10	\$5	\$6	\$4
\$8	\$7	\$20	\$7
\$5	\$4	\$5	\$9

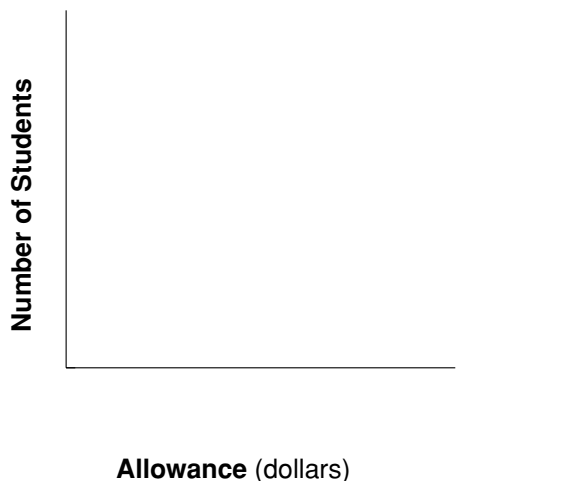

3. Make a double-line graph of the given data. Use the graph to estimate the number of radio stations and cable TV systems in 2002.

Commercial Media in the United States		
Year	Radio Stations	Cable TV Systems
1997	10,207	10,950
1999	10,444	10,700
2001	10,516	9,924
2003	10,605	9,339

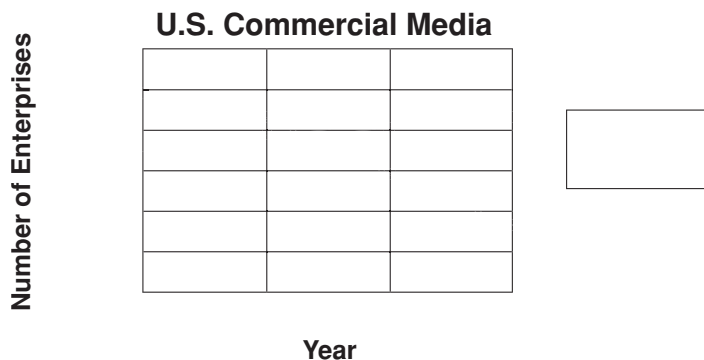

LESSON **Practice**
9-6 **Misleading Graphs and Statistics**

Explain why each graph is misleading.

1. **On the Road**
Number of Trucks that Travel City Roads

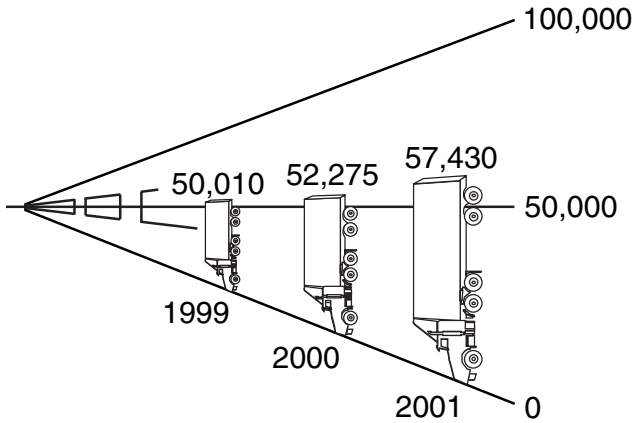

2. **Federal Minimum Wage Rates Since 1980**

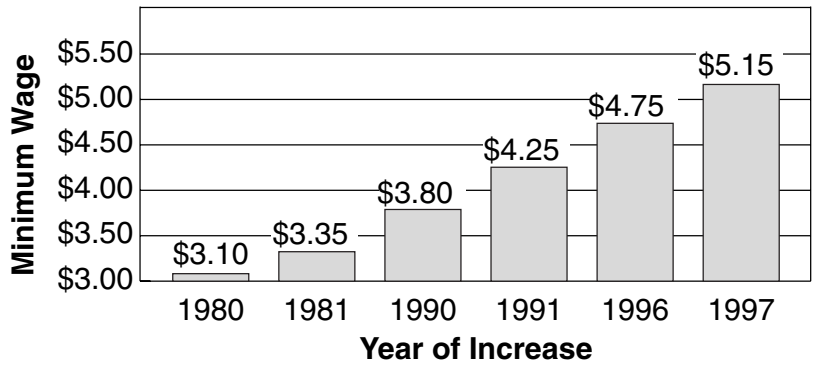

Explain why the statistic is misleading.

3. A chewing gum company advertises that the flavor of its new chewing gum lasts for an average of 55 minutes based on the following durations reported by customers: 12 min, 33 min, 5 min, 200 min, and 25 min.

LESSON
9-7 **Practice**
Scatter Plots

1. Use the given data to make a scatter plot.

Tall Buildings in U.S. Cities

Building	City	Stories	Height (meters)
Sears Tower	Chicago	110	442
Empire State Building	New York	102	381
Bank of America Plaza	Atlanta	55	312
Library Tower	Los Angeles	75	310
Key Tower	Cleveland	57	290
Columbia Seafirst Center	Seattle	76	287
NationsBank Plaza	Dallas	72	281
NationsBank Corporate Center	Charlotte	60	265

Tall Buildings in U.S. Cities

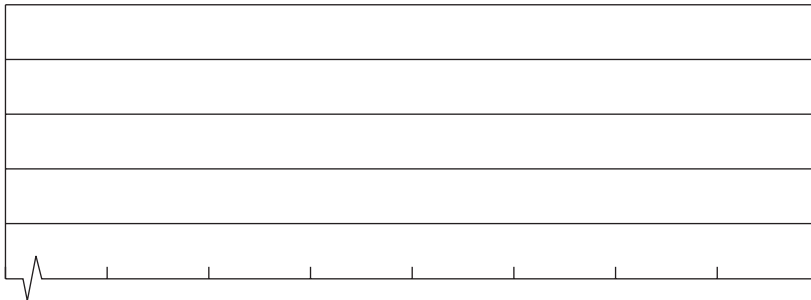

Do the data sets have a positive, a negative, or no correlation?

- | | |
|--|---|
| <p>2. The temperature outside and the number of ice cream cones sold</p> | <p>3. The amount of time spent in the bathtub and the temperature of the bath water</p> |
|--|---|

4. Use the data to predict the percent of Americans owning a home in 1955.

Percent of Americans Owning Homes

Year	1950	1960	1970	1980	1990
Percent	55.0%	61.9%	62.9%	64.4%	64.2%

According to the data, about _____% of Americans owned a home in 1955.

LESSON **Practice**
9-8 **Choosing the Best Representation of Data**

1. Which graph is a better display of the number of students in a class who chose math as their favorite subject?

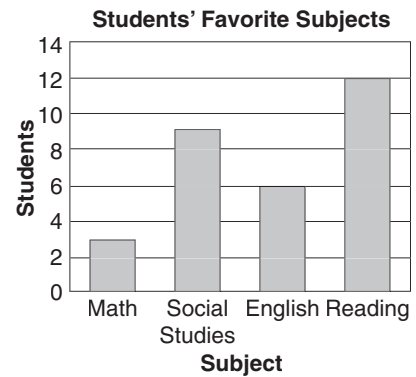
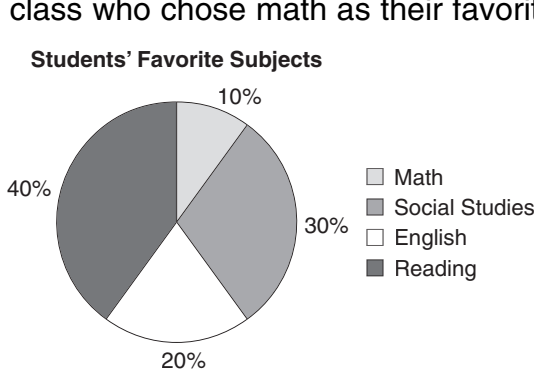

2. Which graph is a better display of the change in the number of cell telephone subscribers?

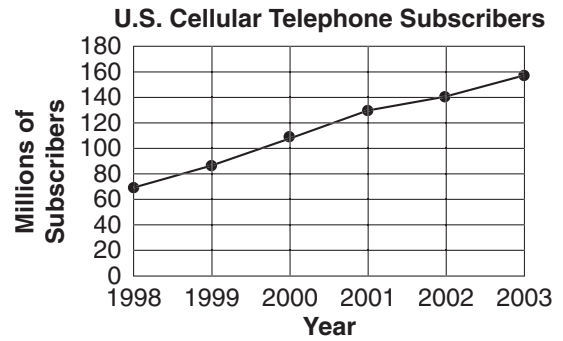
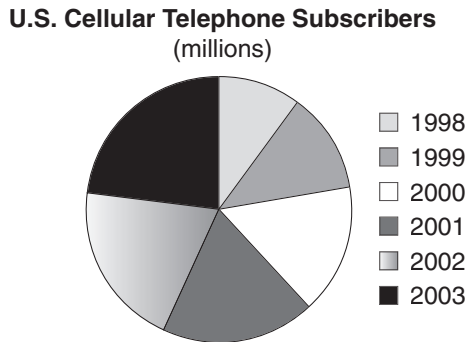

3. The table shows the heights of players on a school basketball team. Choose an appropriate data display and draw the graph.

Heights of Basketball Players (in.)			
70	64	68	71
61	68	65	73

LESSON **Practice**
10-1 **Probability**

These are the results of the last math test. The teacher determines that anyone with a grade of more than 70 passed the test. Give the probability for the indicated grade.

Grade	65	70	80	90	100
# of Students	5	3	12	10	2

1. $P(70)$ _____
2. $P(100)$ _____
3. $P(80)$ _____
4. $P(\text{passing})$ _____
5. $P(\text{grade} > 80)$ _____
6. $P(60)$ _____
7. $P(\text{failing})$ _____
8. $P(\text{grade} \leq 80)$ _____

A bowling game consists of rolling a ball and knocking up to 5 pins down. The number of pins knocked down are then counted. The table gives the probability of each outcome.

Number of Pins Down	0	1	2	3	4	5
Probability	0.175	0.189	0.264	0.205	0.132	0.035

9. What is the probability of knocking down all 5 pins?

10. What is the probability of knocking down no pins?

11. What is the probability of knocking down at most 2 pins?

12. What is the probability of knocking down at least 2 pins?

13. What is the probability of knocking down more than 3 pins?

LESSON
10-2 **Practice**
Experimental Probability

1. A number cube was thrown 150 times. The results are shown in the table below. Estimate the probability for each outcome.

Outcome	1	2	3	4	5	6
Frequency	33	21	15	36	27	18
Probability						

A movie theater sells popcorn in small, medium, large and jumbo sizes. The customers of the first show purchase 4 small, 20 medium, 40 large, and 16 jumbo containers of popcorn. Estimate the probability of the purchase of each of the different size containers of popcorn.

2. $P(\text{small container})$ 3. $P(\text{medium container})$

4. $P(\text{large container})$ 5. $P(\text{jumbo container})$

Janessa polled 154 students about their favorite winter sport.

Outcome	Frequency
Skiing	46
Sledding	21
Snowboarding	64
Ice Skating	14
Other	9

6. Use the table to compare the probability that a student chose snowboarding to the probability that a student chose skiing.

7. Use the table to compare the probability that a student chose ice skating to the probability that a student chose sledding.

8. The class president made 75 copies of the flyer advertising the school play. It was found that 8 of the copies were defective. Estimate the probability that a flyer will be printed properly.

LESSON
10-3 **Practice**
Use a Simulation

Use the table of random numbers for the problems below.

8125	4764	7693	3675	1642	7988	7048	9135	3138	3256
9566	4413	7215	7992	4320	7438	3805	5473	8847	2397
7336	5393	8623	8570	5095	5685	6695	3570	3605	4656
6470	6065	8239	2953	5942	6496	8899	0701	5368	2106
5210	2570	8137	3587	3578	6657	6636	7188	5717	1770
4329	4110	2655	8258	9928	3873	5609	3695	7091	0368
5315	2654	0484	4601	4336	6624	5403	5870	8545	3905
2361	9097	3753	2498	0544	0923	6099	1737	4025	1221
2677	7741	5342	9844	3722	5120	8742	1382	2842	7386
3292	5084	1130	2747	0664	9718	6072	9432	7008	2024

Mr. Domino gave the same math test to all three of his math classes. In the first two classes, 80% of the students passed the test. If the third class has 20 students, estimate the number of students who will pass the test.

- Using the first row as the first trial, count the successful outcomes and name the unsuccessful outcomes.

- Count and name the successful outcomes in the second row as the second trial.

Determine the successful outcomes in the remaining rows of the random number table.

- third row

- fourth row

- fifth row

- sixth row

- seventh row

- eighth row

- ninth row

- tenth row

- Based on the simulation, estimate the probability that 80% of the class will pass the math test.

LESSON

Practice**10-4****Theoretical Probability**

An experiment consists of rolling one fair number cube.
Find the probability of each event.

1. $P(3)$

2. $P(7)$

3. $P(1 \text{ or } 4)$

4. $P(\text{not } 5)$

5. $P(< 5)$

6. $P(> 4)$

7. $P(2 \text{ or odd})$

8. $P(\leq 3)$

An experiment consists of rolling two fair number cubes.
Find the probability of each event.

9. $P(\text{total shown} = 3)$

10. $P(\text{total shown} = 7)$

11. $P(\text{total shown} = 9)$

12. $P(\text{total shown} = 2)$

13. $P(\text{total shown} = 4)$

14. $P(\text{total shown} = 13)$

15. $P(\text{total shown} > 8)$

16. $P(\text{total shown} \leq 12)$

17. $P(\text{total shown} < 7)$

18. A bag contains 9 pennies, 8 nickels, and 5 dimes. How many quarters should be added to the bag so the probability of drawing a dime is $\frac{1}{6}$?

19. In a game two fair number cubes are rolled. To make the first move, you need to roll a total of 6, 7, or 8. What is the probability that you will be able to make the first move?

LESSON **Practice**
10-5 *Independent and Dependent Events*

Determine if the events are dependent or independent.

1. choosing a tie and shirt from the closet _____
2. choosing a month and tossing a coin _____
3. rolling two fair number cubes once, then rolling them again if you received the same number on both number cubes on the first roll _____

An experiment consists of rolling a fair number cube and tossing a fair coin.

4. Find the probability of getting a 5 on the number cube and tails on the dime. _____
5. Find the probability of getting an even number on the number cube and heads on the dime. _____
6. Find the probability of getting a 2 or 3 on the number cube and heads on the dime. _____

A box contains 3 red marbles, 6 blue marbles, and 1 white marble. The marbles are selected at random, one at a time, and are not replaced. Find the probability.

- | | | |
|---|--|--|
| 7. $P(\text{blue and red})$
_____ | 8. $P(\text{white and blue})$
_____ | 9. $P(\text{red and white})$
_____ |
| 10. $P(\text{red and white and blue})$
_____ | 11. $P(\text{red and red and blue})$
_____ | 12. $P(\text{red and blue and blue})$
_____ |
| 13. $P(\text{red and red and red})$
_____ | 14. $P(\text{white and blue and blue})$
_____ | 15. $P(\text{white and red and white})$
_____ |

LESSON **Practice**
10-6 *Making Decisions and Predictions*

A sports store sells water bottles in different colors. The table shows the colors of the last 200 water bottles sold. The manager plans to order 1800 new water bottles.

Water Bottles Sold

Color	Number
Red	30
Blue	50
Green	25
Yellow	10
Purple	10
Clear	75

- How many red water bottles should the manager order? _____
- How many green water bottles should the manager order? _____
- How many clear water bottles should the manager order? _____
- If the carnival spinner lands on 10, the player gets a large stuffed animal. Suppose the spinner is spun 30 times. Predict how many large stuffed animals will be given away. _____

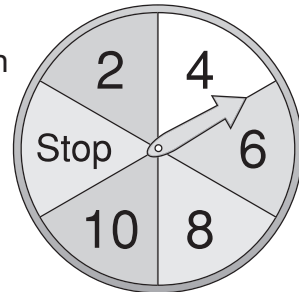

Decide whether the game is fair.

- Roll two fair number cubes labeled 1–6. Player A wins if both numbers are the same. Player B wins if both numbers are different.

- Roll two fair number cubes labeled 1–6. Add the numbers. Player A wins if the sum is 5 or less. Player B wins if the sum is 9 or more.

- Toss three fair coins. Player A wins if exactly one tail lands up. Otherwise, Player B wins.

LESSON **Practice**
10-7 Odds

A bag contains 9 red marbles, 5 green marbles, and 6 purple marbles.

1. Find $P(\text{red marble})$ 2. Find $P(\text{green marble})$ 3. Find $P(\text{purple marble})$

4. Find the odds in favor of choosing a red marble.

5. Find the odds against choosing a red marble.

6. Find the odds in favor of choosing a green marble.

7. Find the odds against choosing a green marble.

8. Find the odds in favor of choosing a purple marble.

9. Find the odds against choosing a purple marble.

10. Find the odds in favor of not choosing a green marble.

11. Find the odds in favor of choosing a red or purple marble.

12. If the probability of Helena winning the contest is $\frac{2}{5}$, what are the odds in favor of Helena winning the contest?

13. The odds in favor of the Bruins winning the Stanley Cup are 5 to 4. What is the probability that the Bruins will win the Stanley Cup?

LESSON
10-8 **Practice**
Counting Principles

Employee identification codes at a company contain 2 letters followed by 2 numbers. All codes are equally likely.

- | | |
|---|---|
| <p>1. Find the number of possible identification codes.</p> <p>_____</p> | <p>2. Find the probability of being assigned the code MT49.</p> <p>_____</p> |
|---|---|

- | | |
|--|--|
| <p>3. Find the probability that an ID code of the company does not contain the letter <i>A</i> as the second letter of the code.</p> <p>_____</p> | <p>4. Find the probability that an ID code of the company does not contain the number 2.</p> <p>_____</p> |
|--|--|

5. Mrs. Sharpe is planning her dinners for next week. The choices for the entree are roast beef, turkey, or pork. The choices of carbohydrates are mashed potatoes, baked potatoes, or noodles. The vegetable choices are broccoli, spinach, or carrots. Make a tree diagram indicating the possible outcomes for each entree.

6. How many different meals could Mrs. Sharpe prepare? _____

Find the probability for each of the following.

- | | |
|---|--|
| <p>7. $P(\text{dinner with baked potato})$</p> <p>_____</p> | <p>8. $P(\text{dinner with noodles and carrots})$</p> <p>_____</p> |
|---|--|

9. Mitch bought 2 sports magazines, 3 guitar magazines, and 3 news magazines. How many choices of magazines does he have to read?

LESSON
10-9 **Practice**
Permutations and Combinations

Evaluate each expression.

1. $10!$

2. $13!$

3. $11! - 8!$

4. $12! - 9!$

5. $\frac{15!}{8!}$

6. $\frac{18!}{12!}$

7. $\frac{13!}{(17 - 12)!}$

8. $\frac{19!}{(15 - 2)!}$

9. $\frac{15!}{(18 - 10)!}$

10. Signaling is a means of communication through signals or objects. During the time of the American Revolution, the colonists used combinations of a barrel, basket, and a flag placed in different positions atop a post. How many different signals could be sent by using 3 flags, one above the other on a pole, if 8 different flags were available?

11. From a class of 25 students, how many different ways can 4 students be selected to serve in a mock trial as the judge, defending attorney, prosecuting attorney, and the defendant?

12. How many different 4 people committees can be formed from a group of 15 people?

13. The girls' basketball team has 12 players. If the coach chooses 5 girls to play at a time, how many different teams can be formed?

14. A photographer has 50 pictures to be placed in an album. How many combinations will the photographer have to choose from if there will be 6 pictures placed on the first page?

LESSON
11-1 Practice
Simplifying Algebraic Expressions**Combine like terms.**

1. $8a - 5a$

2. $12g + 7g$

3. $4a + 7a + 6$

4. $6x + 3y + 5x$

5. $10k - 3k + 5h$

6. $3p - 7q + 14p$

7. $3k + 7k + 5k$

8. $5c + 12d - 6$

9. $13 + 4b + 6b - 5$

10. $4f + 6 + 7f - 2$

11. $x + y + 3x + 7y$

12. $9n + 13 - 8n - 6$

Simplify.

13. $4(x + 3) - 5$

14. $6(7 + x) + 5x$

15. $3(5 + 3x) - 4x$

Solve.

16. $6y + 2y = 16$

17. $14b - 9b = 35$

18. $3q + 9q = 48$

19. Gregg has q quarters and p pennies. His brother has 4 times as many quarters and 8 times as many pennies as Gregg has. Write the sum of the number of coins they have, and then combine like terms.

20. If Gregg has 6 quarters and 15 pennies, how many total coins do Gregg and his brother have?

LESSON **Practice**
11-2 Solving Multi-Step Equations

Solve.

1. $2x + 5x + 4 = 25$

2. $9 + 3y - 2y = 14$

3. $16 = 4w + 2w - 2$

4. $26 = 3b - 2 - 7b$

5. $31 + 4t - t = 40$

6. $14 - 2x + 4x = 20$

7. $\frac{5m}{8} - \frac{6}{8} + \frac{3m}{8} = \frac{2}{8}$

8. $-4\frac{2}{3} = \frac{2n}{3} + \frac{1}{3} + \frac{n}{3}$

9. $7a + 16 - 3a = -4$

10. $\frac{x}{2} + 1 + \frac{3x}{4} = -9$

11. $7m + 3 - 4m = -9$

12. $\frac{2x}{5} + 3 - \frac{4x}{5} = \frac{1}{5}$

13. $\frac{7k}{8} - \frac{3}{4} - \frac{5k}{16} = \frac{3}{8}$

14. $6y + 9 - 4y = -3$

15. $\frac{5a}{6} - \frac{7}{12} + \frac{3a}{4} = -2\frac{1}{6}$

16. The measure of an angle is 28° greater than its complement.
Find the measure of each angle.
- _____

17. The measure of an angle is 21° more than twice its supplement.
Find the measure of each angle.
- _____

18. The perimeter of the triangle is 126 units.
Find the measure of each side.
- _____
- _____

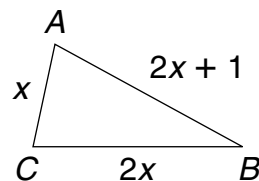

19. The base angles of an isosceles triangle are congruent. If the measure of each of the base angles is twice the measure of the third angle, find the measure of all three angles.
- _____

LESSON **Practice**
11-3 *Solving Equations with Variables on Both Sides*

Solve.

1. $7x - 11 = -19 + 3x$

2. $11a + 9 = 4a + 30$

3. $4t + 14 = \frac{6t}{5} + 7$

4. $19c + 31 = 26c - 74$

5. $\frac{3y}{8} - 9 = 13 + \frac{y}{8}$

6. $\frac{3k}{5} + 44 = \frac{12k}{25} + 8$

7. $10a - 37 = 6a + 51$

8. $5w + 9.9 = 4.8 + 8w$

9. $15 - x = 2(x + 3)$

10. $15y + 14 = 2(5y + 6)$

11. $14 - \frac{w}{8} = \frac{3w}{4} - 21$

12. $\frac{1}{2}(6x - 4) = 4x - 9$

13. $4(3d - 2) = 8d - 5$

14. $\frac{y}{3} + 11 = \frac{y}{2} - 3$

15. $\frac{2x - 9}{3} = 8 - 3x$

16. Forty-eight decreased by a number is the same as the difference of four times the number and seven. Find the number.

17. The square and the equilateral triangle at the right have the same perimeter. Find the length of the sides of the triangle.

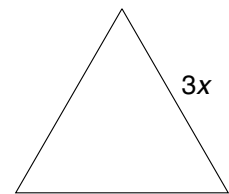
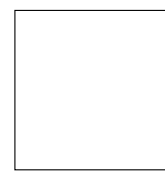

LESSON

Practice

11-4 Solving Inequalities by Multiplying or Dividing

Solve and graph.

1. $\frac{m}{-5} \leq 4$

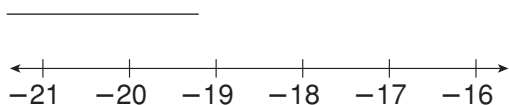

2. $-16 < -8n$

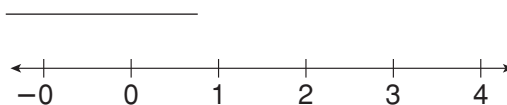

3. $7p \geq 49$



4. $10 > \frac{q}{2}$



5. $-\frac{r}{3} \leq 15$

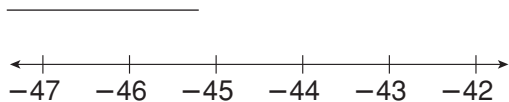

6. $22 > -2s$

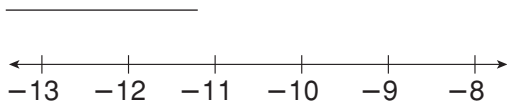

7. $-6t < -24$

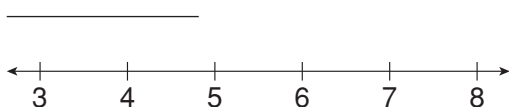

8. $\frac{v}{20} \geq 2$

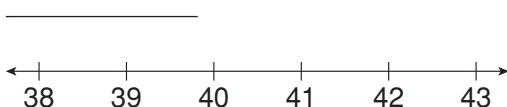

9. On a snorkeling trip, Antonia dove at least 7 times as deep as Lucy did. If Antonia dove 35 feet below the ocean's surface, what was the deepest that Lucy dove?

10. Last week, Saul ran more than one-fifth the distance that his friend Omar ran. If Saul ran 14 miles last week, how far did Omar run?

LESSON **Practice**
11-5 Solving Two-Step Inequalities

Solve and graph.

1. $4x - 2 < 26$

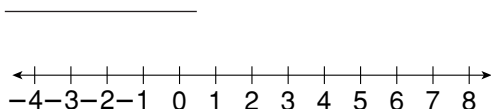

2. $6 - \frac{1}{5}y \leq 7$

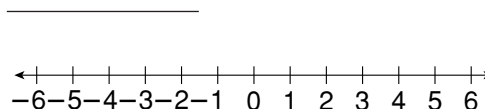

3. $2x + 27 \geq 15$

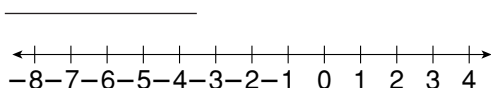

4. $10x > 14x + 8$

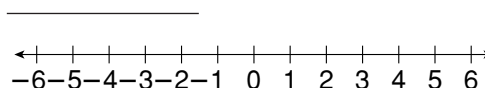

5. $7 - 4w \leq 19$

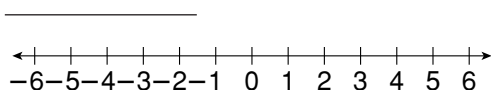

6. $\frac{k}{5} + \frac{3}{20} < \frac{3}{10}$



7. $4.8 - 9.6x \leq 14.4$

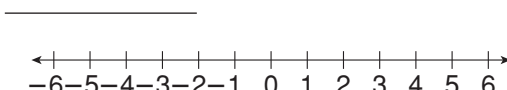

8. $\frac{2}{9} + \frac{y}{3} > \frac{1}{3}$



9. One-third of a number, decreased by thirty-six, is at most twenty-two. Find the number. _____

10. Jack wants to run at least 275 miles before the baseball season begins. He has already run 25 miles. He plans to run 2.5 miles each day. At this rate, what is the fewest number of days he will need to reach his goal? _____

LESSON

Practice

11-6 *Systems of Equations*

Solve each system of equations.

1. $y = 2x - 4$
 $y = x - 1$

2. $y = -x + 10$
 $y = x + 2$

3. $y = 2x - 1$
 $y = -3x - 6$

4. $y = 2x$
 $y = 12 - x$

5. $y = 2x - 3$
 $y = 2x + 1$

6. $y = 3x - 1$
 $y = x + 1$

7. $x + y = 0$
 $5x + 2y = -3$

8. $2x - 3y = 0$
 $2x + y = 8$

9. $2x + 3y = 6$
 $4x + 6y = 12$

10. $6x - y = -14$
 $2x - 3y = 6$

11. The sum of two numbers is 24. The second number is 6 less than the first. Write a system of equations and solve it find the number.

15. Kerry and Luke biked a total of 18 miles in one weekend. Kerry biked 4 miles more than Luke. Write a system of equations and solve it to find how far each boy biked.

LESSON **Practice**
12-1 *Graphing Linear Equations*

Graph each equation and tell whether it is linear.

1. $y = -2x - 5$

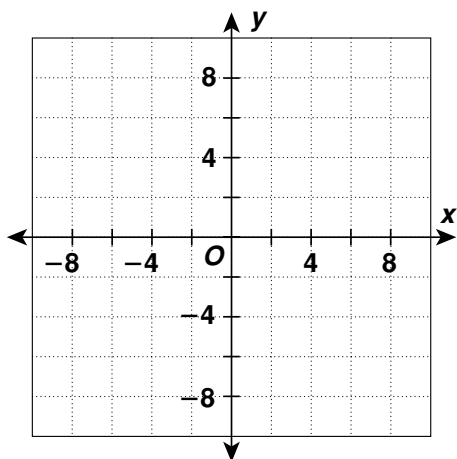

2. $y = -x^2 + 1$

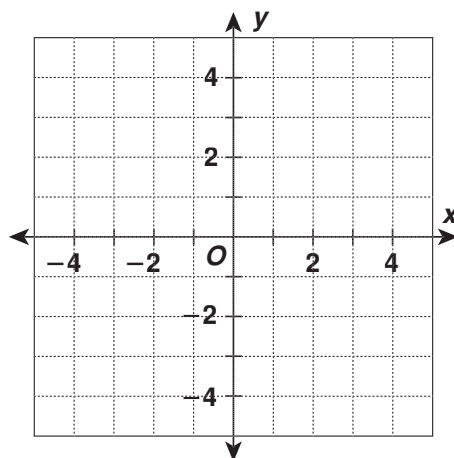

3. $y = x^2 - 7$

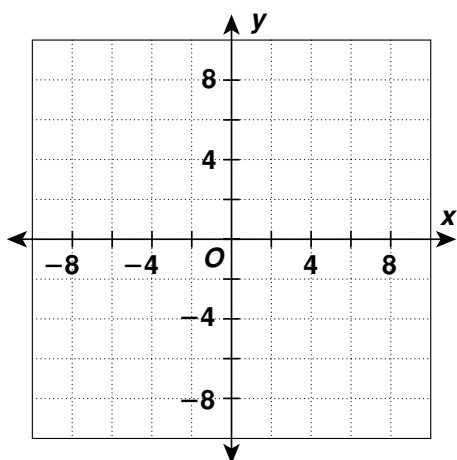

4. $y = \frac{1}{2}x - 1$

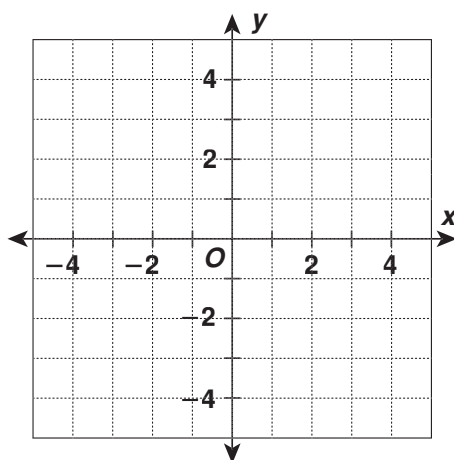

5. A real estate agent commission may be based on the equation $C = 0.06s + 450$, where s represents the total sales. If the agent sells a property for \$125,000, what is the commission earned by the agent? Graph the equation and tell whether it is linear.

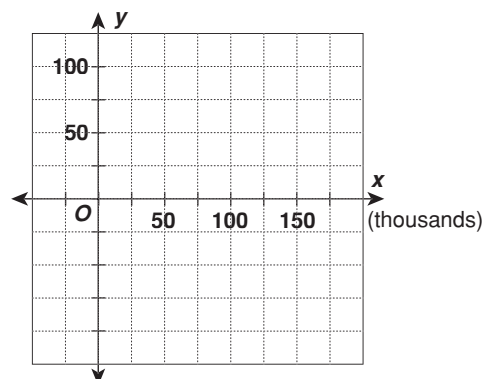

LESSON **Practice**
12-2 *Slope of a Line*

Find the slope of the line that passes through each pair of points.

1. $(-2, -8), (1, 4)$ 2. $(-2, 0), (0, 4),$ 3. $(0, 4), (4, 4)$ 4. $(3, -6), (2, -4)$

5. $(-3, 4), (3, -4)$ 6. $(3, 0), (0, -6),$ 7. $(3, 2), (3, -2)$ 8. $(-4, 4), (3, -1)$

Determine whether each graph shows a constant or variable rate of change. Explain your reasoning.

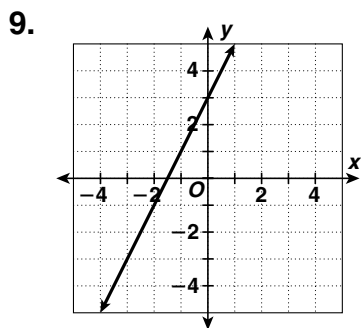

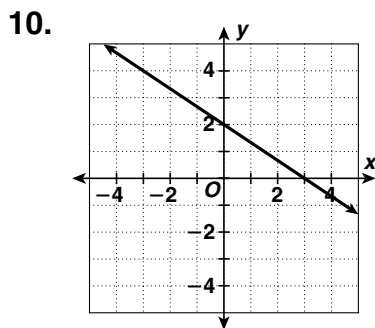

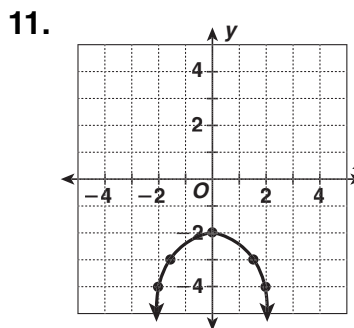

12. The table shows the distance Ms. Long had traveled as she went to the beach. Use the data to make a graph. Find the slope of the line and explain what it shows.

Time (min)	Distance (mi)
8	6
12	9
16	12
20	15

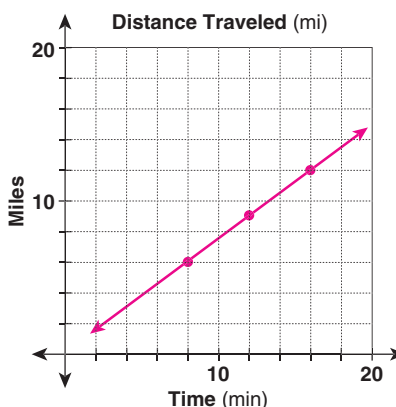

LESSON **Practice**
12-3 *Using Slopes and Intercepts*

Find the x -intercept and y -intercept of each line.
 Use the intercepts to graph the equation.

1. $x - y = -3$

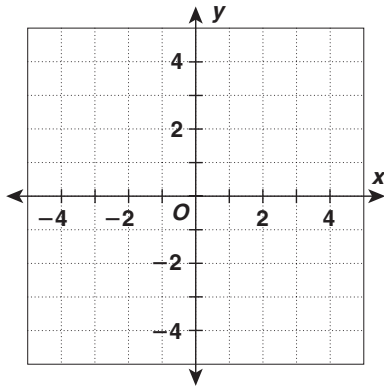

2. $2x + 3y = 12$

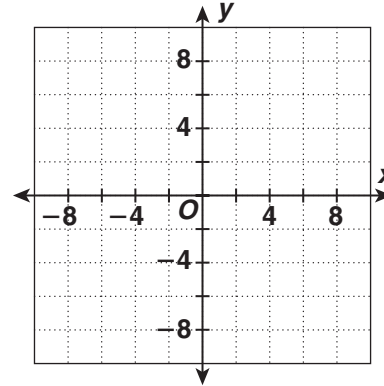

Write each equation in slope-intercept form, and then find the slope and y -intercept.

3. $3x + y = 0$

4. $2x - y = -15$

5. $x - 5y = 10$

Write the equation of the line that passes through each pair of points in slope-intercept form.

6. $(3, 4), (4, 6)$

7. $(-1, -1), (2, -10)$

8. $(6, 5), (-9, -20)$

9. A pizzeria charges \$8 for a large cheese pizza, plus \$2 for each topping. The total cost for a large pizza is given by the equation $C = 2t + 8$, where t is the number of toppings. Identify the slope and y -intercept, and use them to graph the equation for t between 0 and 5 toppings.

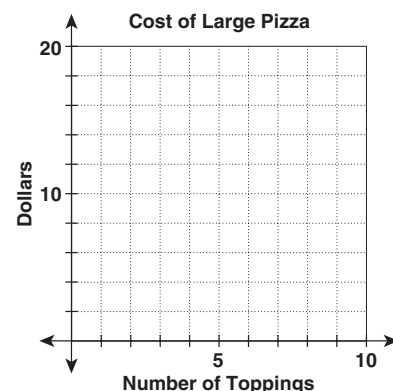

LESSON
12-4 **Practice**
Point-Slope Form

Use the point-slope form of each equation to identify a point the line passes through and the slope of the line.

1. $y - 2 = 4(x - 1)$

2. $y + 1 = 2(x - 3)$

3. $y - 4 = -3(x + 1)$

4. $y + 5 = -2(x + 6)$

5. $y + 4 = -9(x + 3)$

6. $y - 7 = -7(x - 7)$

7. $y - 10 = 6(x - 8)$

8. $y + 12 = 2.5(x + 4)$

9. $y + 8 = \frac{1}{2}(x - 3)$

Write the point-slope form of the equation with the given slope that passes through the indicated point.

10. the line with slope -1 passing through $(2, 5)$

11. the line with slope 2 passing through $(-1, 4)$

12. the line with slope 4 passing through $(-3, -2)$

13. the line with slope 3 passing through $(7, -6)$

14. the line with slope -3 passing through $(-6, 4)$

15. the line with slope -2 passing through $(5, 1)$

16. Michael was driving at a constant speed of 60 mph when he crossed the Sandy River. After 1 hour, he passed a highway marker for mile 84. Write an equation in point-slope form, and find which highway marker he will pass 90 minutes after crossing the Sandy River.

LESSON **Practice**
12-5 *Direct Variation*

Make a graph to determine whether the data sets show direct variation.

1.

x	y
6	9
4	6
0	0
-2	-3
-8	-12

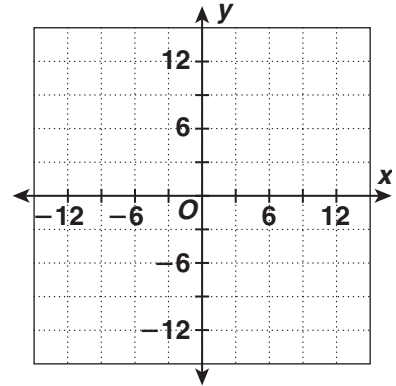

2. Write the equation of direct variation for Exercise 1.

Find each equation of direct variation, given that y varies with x .

3. y is 32 when x is 4

4. y is -10 when x is -20

5. y is 63 when x is -7

6. y is 40 when x is 50

7. y is 87.5 when x is 25

8. y is 90 when x is 270

9. The table shows the length and width of various U.S. flags. Determine whether there is direct variation between the two data sets. If so, find the equation of direct variation.

Length (ft)	2.85	5.7	7.6	9.88	11.4
Width (ft)	1.5	3	4	5.2	6

LESSON **Practice**
12-6 *Graphing Inequalities in Two Variables*

Graph each inequality.

1. $y \geq 2x + 3$

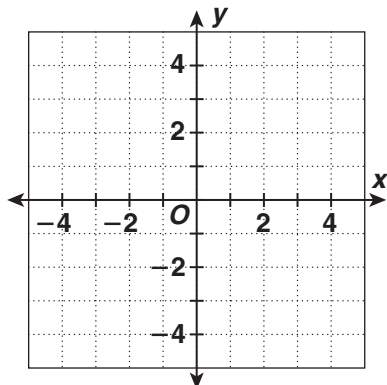

2. $y - 4x \leq 1$

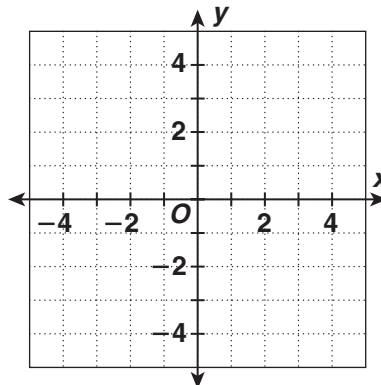

3. $2(3x - y) > 6$

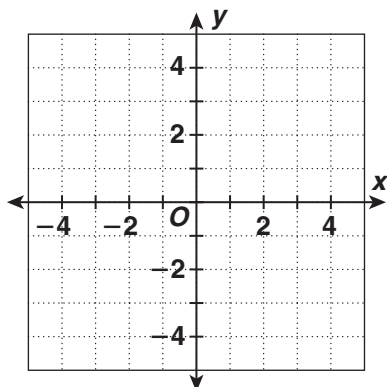

4. $y \geq \frac{3}{4}x - 1$

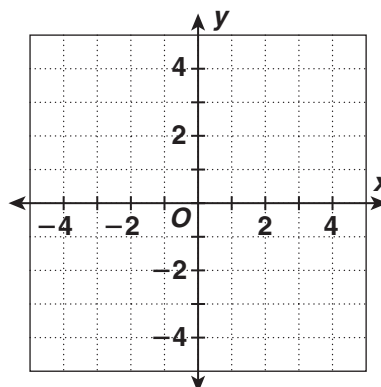

5. a. A theater club hopes to raise at least \$550 on the opening night of its new show. Student tickets for the show cost \$2.75, and adult tickets cost \$5.50. Write and graph an inequality showing the numbers of tickets that would meet the club's goal.

b. If the club sells 95 student tickets and 40 adult tickets, will it meet its goal?

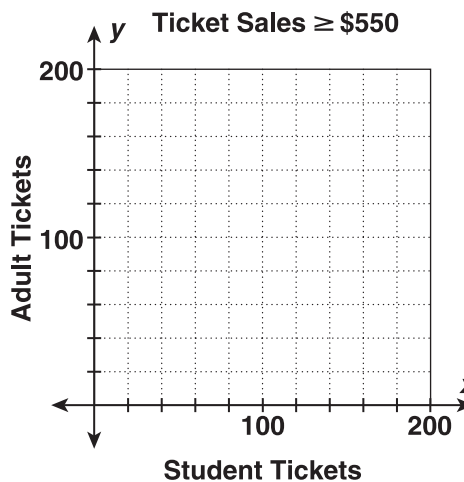

LESSON **Practice**
12-7 *Lines of Best Fit*

Plot the data and find a line of best fit.

1.

x	20	30	50	60	80	90	110	120
y	13	20	40	54	75	82	100	112

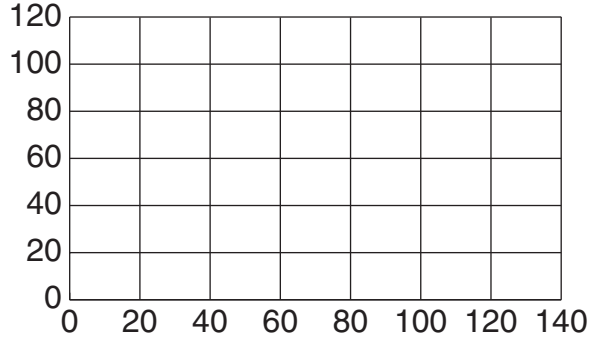

2.

x	1.9	2.9	4.8	2.5	3.9	2.3	6.3	3.4
y	26	34	58	31	52	27	76	48

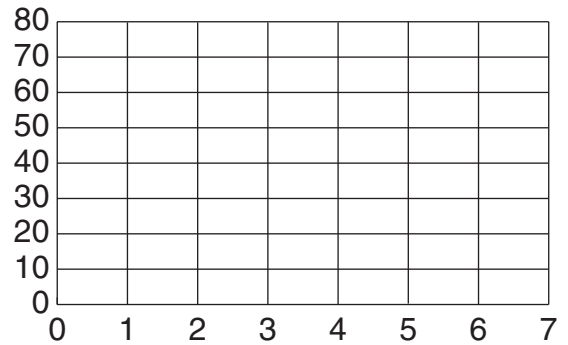

3. Find the line of best fit for the student enrollment data. Use the equation of the line to predict what the enrollment at Columbus Junior High School will be in year 10. Is it reasonable to make this prediction? Explain.

Enrollment	405	485	557	593	638	712
Year	1	2	3	4	5	6

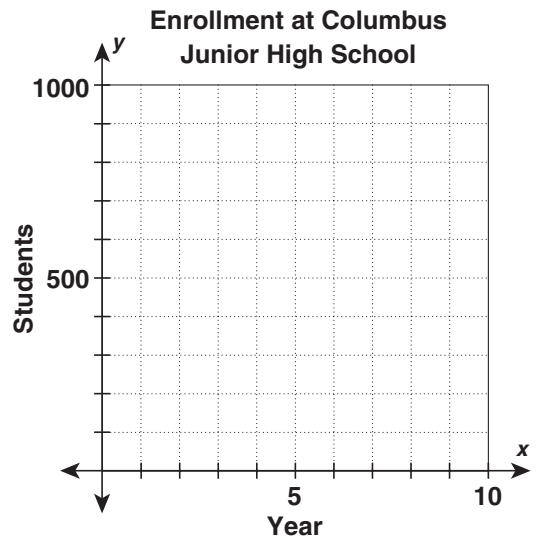

LESSON **Practice**
13-1 *Terms of Arithmetic Sequences*

Determine if each sequence could be arithmetic. If so, give the common difference.

1. 18, 20, 22, 24, 26, ... 2. 48, 42, 36, 30, 24, ... 3. 15, 30, 60, 120, 240, ...

4. 10.4, 8.3, 6.2, 4.1, 2, ... 5. $\frac{1}{3}, \frac{1}{9}, \frac{1}{27}, \frac{1}{81}, \frac{1}{243}, \dots$ 6. 83, 66, 49, 32, 15, ...

7. 8.1, 2.7, 0.9, 0.3, 0.1, ... 8. $\frac{2}{3}, \frac{4}{3}, 2, \frac{8}{3}, \frac{10}{3}, \dots$ 9. -58, -35, -12, 11, 34, ...

Find the given term in each arithmetic sequence.

10. 14th term: 60, 68, 76, 84, 92, ... 11. 35th term: 3.5, 3.8, 4.1, 4.4, 4.7, ...

12. 21st term: 103, 84, 65, 46, 27, ... 13. 22nd term: -2, -5, -8, -11, -14, ...

14. 16th term: 73, 44, 15, -14, -43, ... 15. 50th term: -9, 2, 13, 24, 35, ...

16. 19th term: -87, -78, -69, -60, -51, ... 17. 25th term: $3\frac{1}{4}, 3\frac{1}{2}, 3\frac{3}{4}, 4, 4\frac{1}{4}, \dots$

18. A cook started with 26 ounces of special sauce. She used 1.4 ounces of the sauce in each of a number of dishes and had 2.2 ounces left over. How many dishes did she make with the sauce?

19. Kuang started the basketball season with 54 points in his career. He scores 3 points more each game he plays. How many games will it take for him to have scored a total of 132 points in his basketball career?

LESSON **Practice**
13-2 *Terms of Geometric Sequences*

Determine if each sequence could be geometric. If so, give the common ratio.

1. 4, 16, 64, 256, 1024, ... 2. $3, \frac{3}{2}, \frac{3}{4}, \frac{3}{8}, \frac{3}{16}, \dots$ 3. 5, 10, 15, 20, 25, ...

4. 3, 18, 108, 648, 3888, ... 5. 1250, 125, 12.5, 1.25, 0.125, ... 6. 10, 15, 22.5, 33.75, 50.625, ...

7. $36, 12, 4, \frac{4}{3}, \frac{4}{9}, \dots$ 8. 1440, 720, 240, 60, 12, ... 9. 9, 3, 1, 0.5, 0.25, ...

Find the given term in each geometric sequence.

10. 6th term: 25, 75, 225, 675, ...

11. 10th term: 320, 160, 80, 40, ...

12. 9th term: 4.5, 9, 18, 36, ...

13. 7th term: 0.02, 0.2, 2, 20, ...

14. 12th term: $\frac{1}{1000}, \frac{1}{100}, \frac{1}{10}, 1, \dots$

15. 8th term: $\frac{3}{8}, \frac{3}{4}, \frac{3}{2}, 3, \dots$

16. In an experiment a population of flies triples every week. The experiment starts with 12 flies. How many flies will there be by the end of week 5?

17. A small business earned \$21 in its first month. It quadrupled this amount each month for the next several months. How much did the business earn in the 4th month?

LESSON **Practice**
13-3 *Other Sequences*

Use first and second differences to find the next three terms in each sequence.

1. 3, 6, 10, 15, 21, ...

2. 11, 14, 18, 25, 37, ...

3. 10, 16, $22\frac{1}{3}$, 29, 36, ...

4. 14.5, 22.5, 31, 40, 49.5, ...

Give the next three terms in each sequence using the simplest rule you can find.

5. 6, 7, 10, 19, 38, ...

6. 0.5, 2, 4.5, 8, 12.5, ...

7. 36, 55, 80, 111, 148, ...

8. 3, 10, 21, 36, 55, ...

9. 1, 6, 15, 28, 45, ...

10. 0, 11, 30, 57, 92, ...

Find the first five terms of each sequence defined by the given rule.

11. $a_n = \frac{n^2 + 2}{n}$

12. $a_n = \frac{5n - 2}{n + 1}$

13. $a_n = \frac{3n^2}{n + 2}$

14. Suppose a , b , and c are three consecutive numbers in the Fibonacci sequence. Complete the following table and guess the pattern.

a, b, c	ab	bc
1, 1, 2		
2, 3, 5		
5, 8, 13		
13, 21, 34		
34, 55, 89		

LESSON **Practice**
13-4 **Linear Functions**

Determine whether each function is linear.

1. $f(x) = -3x + 2$

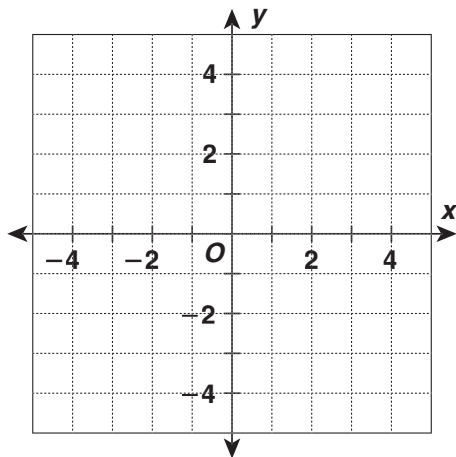

2. $f(x) = x^2 - 1$

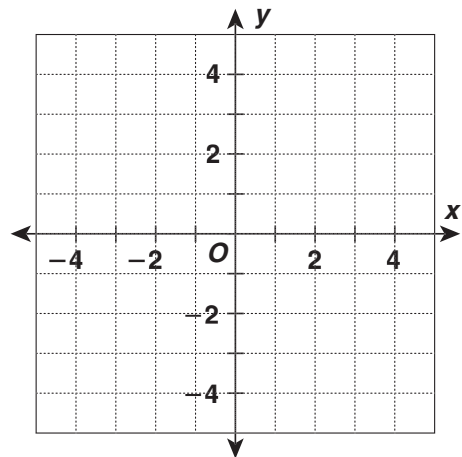

Write a rule for each linear function.

3.

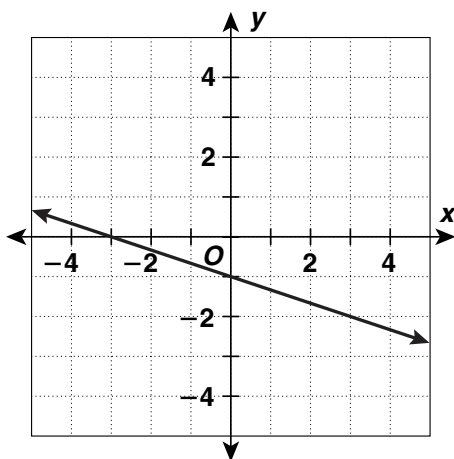

4.

x	y
-3	16
-1	12
3	4
7	-4

5. At the Sweater Store, the price of a sweater is 20% more than the wholesale cost, plus a markup of \$8. Find a rule for a linear function that describes the price of sweaters at the Sweater Store. Use it to determine the price of a sweater with a wholesale cost of \$24.50.

LESSON **Practice**
13-5 Exponential Functions

Create a table for each exponential function, and use it to graph the function.

1. $f(x) = 0.5 \cdot 4^x$

x	y
-1	$y = 0.5 \cdot 4^{-1} = 0.125$
0	
1	
2	

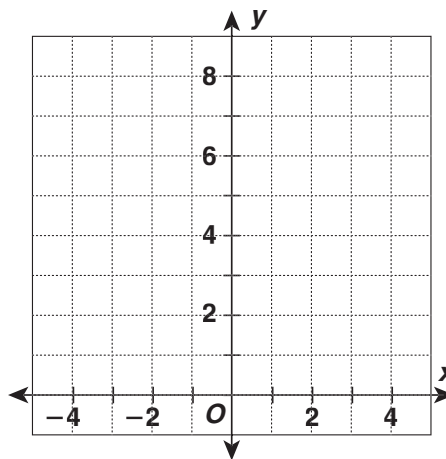

2. $f(x) = \frac{1}{3} \cdot 3^x$

x	y
-1	$y = \frac{1}{3} \cdot 3^{-1} = \frac{1}{9}$
0	
1	
2	

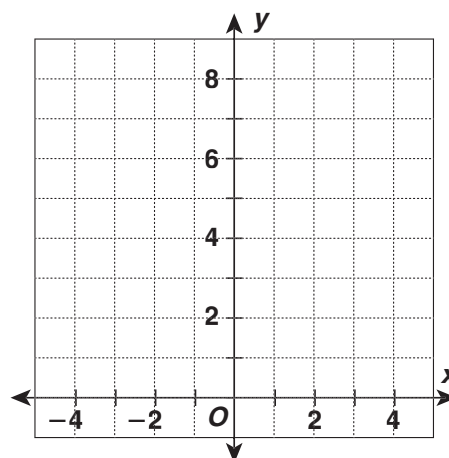

3. A forestry department introduce 500 fish to a lake. The fish are expected to increase at a rate of 35% each year. Write an exponential function to calculate the number of fish in the lake at the end of each year. Predict how many fish will be in the lake at the end of 5 years.

4. A stock valued at \$756 has been declining steadily at the rate of 4% a year for the last few years. If this decline continues, predict what the value of the stock will be at the end of 3 years.

5. Todd's starting salary at his new job is \$400 a week. He is promised a 3% increase in salary every year. Predict to the nearest dollar what Todd's expected yearly salary will be after working for 4 years.

LESSON **Practice**
13-6 Quadratic Functions

Create a table for each quadratic function, and use it to make a graph.

1. $f(x) = x^2 - 5$

x	$f(x) = x^2 - 5$
-3	$f(-3) = (-3)^2 - 5 = 4$
-1	
0	
2	
3	

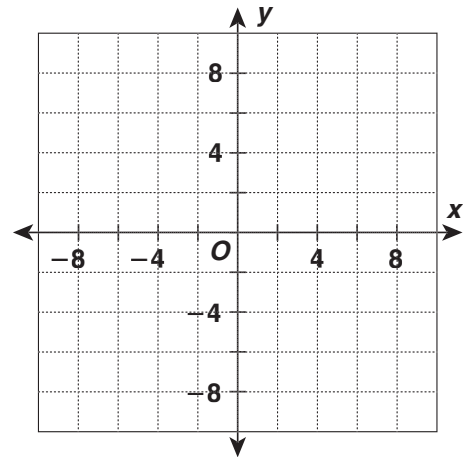

2. $f(x) = x^2 - 2x + 3$

x	$f(x) = x^2 - 2x + 3$
3	
2	
1	
0	
-1	

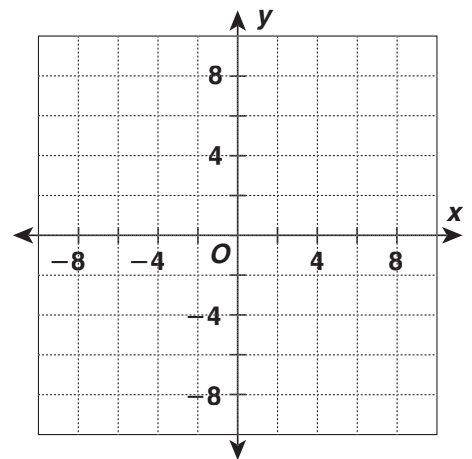

3. Find $f(-3)$, $f(0)$, $f(3)$ for each quadratic function.

	$f(-3)$	$f(0)$	$f(3)$
$f(x) = x^2 - 2x + 1$			
$f(x) = x^2 - 6$			
$f(x) = x^2 - x + 3$			

4. The function $f(t) = -4.9t^2$ gives the distance in meters that an object will fall toward Earth in t seconds. Find the distance an object will fall in 1, 2, 3, 4, and 5 seconds. (Note that the distance traveled by a falling object is shown by a negative number.)

LESSON **Practice**
13-7 *Inverse Variation*

Tell whether each relationship is an inverse variation.

1. The table shows the length and width of certain rectangles.

Length	6	8	12	16	24
Width	8	6	4	3	2

2. The table shows the number of days needed to paint a house for the size of the work crew.

Crew Size	2	3	4	5	6
Days of Painting	21	14	10.5	8.5	7

3. The table shows the time spent traveling at different speeds.

Hours	5	6	8	9	12
mi/h	72	60	45	40	30

Graph each inverse variation function.

4. $f(x) = \frac{4}{x}$

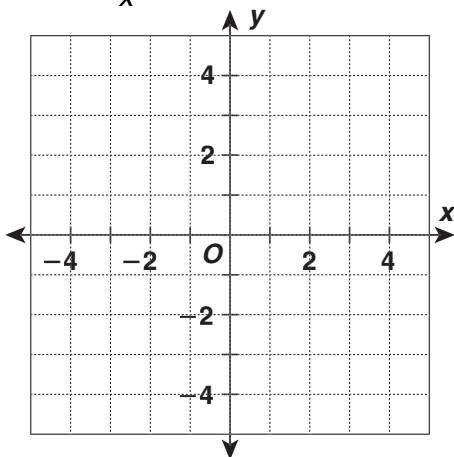

5. $f(x) = \frac{5}{x}$

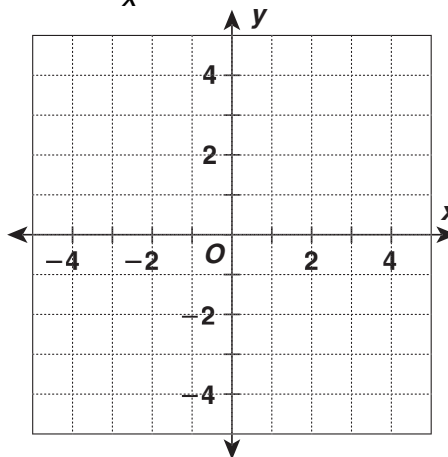

6. Amperes (abbreviated amp) measure the strength of electric current. An ohm is the unit of electrical resistance. In an electric circuit, the current varies inversely as the resistance. If the current is 24 amps when the resistance is 20 ohms, find the inverse variation function and use it to find the resistance in ohms when the current is 40 amps. _____

LESSON
14-1 **Practice**
Polynomials

Determine whether each expression is a monomial.

1. $-135x^5$

2. $2.4x^3y^{19}$

3. $\frac{2p^2}{q^3}$

4. $3r^{\frac{1}{2}}$

5. $43a^2b^{6.1}$

6. $\frac{7}{9}x^2yz^5$

Classify each expression as a monomial, a binomial, a trinomial, or not a polynomial.

7. $-8.9xy + \frac{6}{y^5}$

8. $\frac{9}{8}ab^8c^2d$

9. $x^8 + x + 1$

10. $-7pq^{-2}r^4$

11. $5n^{15} - 9n + \frac{1}{3}$

12. $r^8 - 5.5r^{75}$

Find the degree of each polynomial.

13. $7 - 14x$

14. $5a + a^2 + \frac{6}{7}a^3$

15. $7w - 16u + 3v$

16. $9p - 9q - 9p^3 - 9q^2$

17. $z^9 + 10y^8 - x$

18. $100,050 + \frac{4}{5}k - k^4$

19. The volume of a box with height x , length $x - 1$, and width $2x + 2$ is given by the trinomial $2x^3 - 2x$. What is the volume of the box if its height is 4 feet?

20. The trinomial $-16t^2 + 32t + 32$ describes the height in feet of a ball thrown upward after t seconds. What is the height of the ball $\frac{5}{8}$ seconds after it was thrown?

LESSON
14-2 **Practice**
Simplifying Polynomials

Identify the like terms in each polynomial.

1. $x^2 - 8x + 3x^2 + 6x - 1$

2. $2c^2 + d^3 + 3d^3 - 2c^2 + 6$

3. $2x^2 - 2xy - 2y^2 + 3xy + 3x^2$

4. $2 - 9x + x^2 - 3 + x$

5. $xy - 5x + y - x + 10y - 3y^2$

6. $6p + 2p^2 + pq + 2q^3 - 2p$

7. $3a + 2b + a^2 - 5b + 7a$

8. $10m - 3m^2 + 9m^2 - 3m - m^3$

Simplify.

9. $2h - 9hk + 6h - 6k$

10. $9(x^2 + 2xy - y^2) - 2(x^2 + xy)$

11. $7qr - q^2r^3 + 2q^2r^3 - 6qr$

12. $8v^4 + 3v^2 + 2v^2 - 16$

13. $3(x + 2y) + 2(2x - 3y)$

14. $7(1 - x) + 3x^2y + 7x - 7$

15. $6(9y + 1) + 8(2 - 3y)$

16. $a^2b - a^2 + ab^2 - 3a^2b + ab$

17. A student in Tracey's class created the following expression:
 $y^3 - 3y + 4(y^2 - y^3)$. Use the Distributive Property to write
an equivalent expression.

LESSON
14-3 **Practice**
Adding Polynomials**Add.**

1. $(a^2 + a + 3) + (15a^2 + 2a + 9)$

2. $(5x + 2x^2) + (3x - 2x^2)$

3. $(mn - 10 + mn^2) + (5 + 3mn - 4mn^2)$

4. $(7y^2z + 9 + yz^2) + (y^2z - 2yz^2)$

5. $(s^3 + 3s - 3) + (2s^3 + 9s - 2) + (s - s^3)$

6. $(6wv - 4w^2v + 7wv^2) + (5w^2v - 7wv^2) + (wv^2 - 5wv + 6w^2v)$

7. $(6b^2c^2 - 4b^2c + 3bc) + (9b^2c^2 - 4bc + 12) + (2b^2c - 3bc - 8)$

8. $(7e^2 + 3e + 2) + (9 - 6e + 4e^2) + (9e + 2 - 6e^2) + (4e^2 - 7e + 8)$

9. $(f^4g - fg^3 + 2fg - 4) + (3fg^3 + 3) + (4f^4g - 5fg) + (3 - 12fg^3 + f^4g)$

10. Six blocks of height $4h + 4$ each and 3 blocks of height $8 - 2h$ each are stacked on top of each other to form one big tower. Find an expression for the overall height of the tower.
-
- _____

LESSON **Practice**
14-4 **Subtracting Polynomials**

Find the opposite of each polynomial.

1. $18xy^3$

2. $-9a + 4$

3. $6d^2 - 2d - 8$

Subtract.

4. $(4n^3 - 4n + 4n^2) - (6n + 3n^2 - 8)$

5. $(-2h^4 + 3h - 4) - (2h - 3h^4 + 2)$

6. $(6m + 2m^2 - 7) - (-6m^2 - m - 7)$

7. $(17x^2 - x + 3) - (14x^2 + 3x + 5)$

8. $w + 7 - (3w^4 + 5w^3 - 7w^2 + 2w - 10)$

9. $(9r^3s - 3rs + 4rs^3 + 5r^2s^2) - (2rs^2 - 2r^2s^2 + 6rs + 7r^3s - 9)$

10. $(3qr^2 - 2 + 14q^2r^2 - 9qr) - (-10qr + 11 - 5qr^2 + 6q^2r^2)$

11. The volume of a rectangular prism, in cubic meters, is given by the expression $x^3 + 7x^2 + 14x + 8$. The volume of a smaller rectangular prism is given by the expression $x^3 + 5x^2 + 6x$. How much greater is the volume of the larger rectangular prism?

12. Sarah has a table with an area, in square inches, given by the expression of $y^2 + 30y + 200$. She has a tablecloth with an area, in square inches, given by the expression of $y^2 + 18y + 80$. She wants the tablecloth to cover the top of the table. What expression represents the number of square inches of additional fabric she needs to cover the top of the table?

LESSON **Practice**
14-5 *Multiplying Polynomials by Monomials***Multiply.**

1. $(x^2)(-3x^2y^3)$

2. $(-9pr^4)(p^2r^2)$

3. $(2st^9)(-st^2)$

4. $(3efg^2)(-3e^2f^2g)$

5. $2q(4q^2 - 2)$

6. $-x(x^2 + 2)$

7. $5m(-3m^2 + 2m)$

8. $6x(-x^5 + 2x^3 + x)$

9. $-4st(st - 12t - 2s)$

10. $-9ab(a^2 + 2ab - b^2)$

11. $-7v^2w^2(vw^2 + 2vw + 1)$

12. $8p^4(p^2 - 8p + 17)$

13. $4x(-x^2 - 2xy + 3)$

14. $7x^2(3x^2y + 7x^2 - 2x)$

15. $-4t^3r^2(3t^2r - t^5r - 6t^2r^2)$

16. $h^2k(2hk^2 - hk + 7k)$

17. A triangle has a base of $4x^2$ and a height of $6x + 3$. Write and simplify an expression for the area of the triangle.

LESSON

Practice**14-6** *Multiplying Binomials***Multiply.**

1. $(z + 1)(z + 2)$

2. $(1 - y)(2 - y)$

3. $(2x + 1)(2x + 4)$

4. $(w + 1)(w - 3)$

5. $(3v + 1)(v - 1)$

6. $(t + 2)(2t - 2)$

7. $(-3g + 4)(2g - 1)$

8. $(3c + d)(c - 2d)$

9. $(2a + b)(a + 2b)$

10. A box is formed from a 1 in. by 18 in. piece of cardboard by cutting a square with side length m inches out of each corner and folding up the sides. Write and simplify an expression for the area of the base of the box.
- _____

11. A table is placed in a 14 ft \times 18 ft room so that there is an equal amount of space of width s feet all the way around the table. Write and simplify an expression for the area of the table.
- _____

12. A circular swimming pool with a radius of 14 ft is surrounded by a deck with width y feet. Write and simplify an expression for the total area of the pool and the deck. Use $\frac{22}{7}$ for pi.
- _____

Multiply.

13. $(r - 2)^2$

14. $(2 + q)^2$

15. $(p + 4)(p - 4)$

16. $(3n - 3)(3n + 3)$

17. $(a + b)(a - b)$

18. $(4e - f)^2$

19. $(2y + z)^2$

20. $(9p - 2)(-2 + 9p)$

21. $(m - 1)^2$
