

Cabinetry Installation

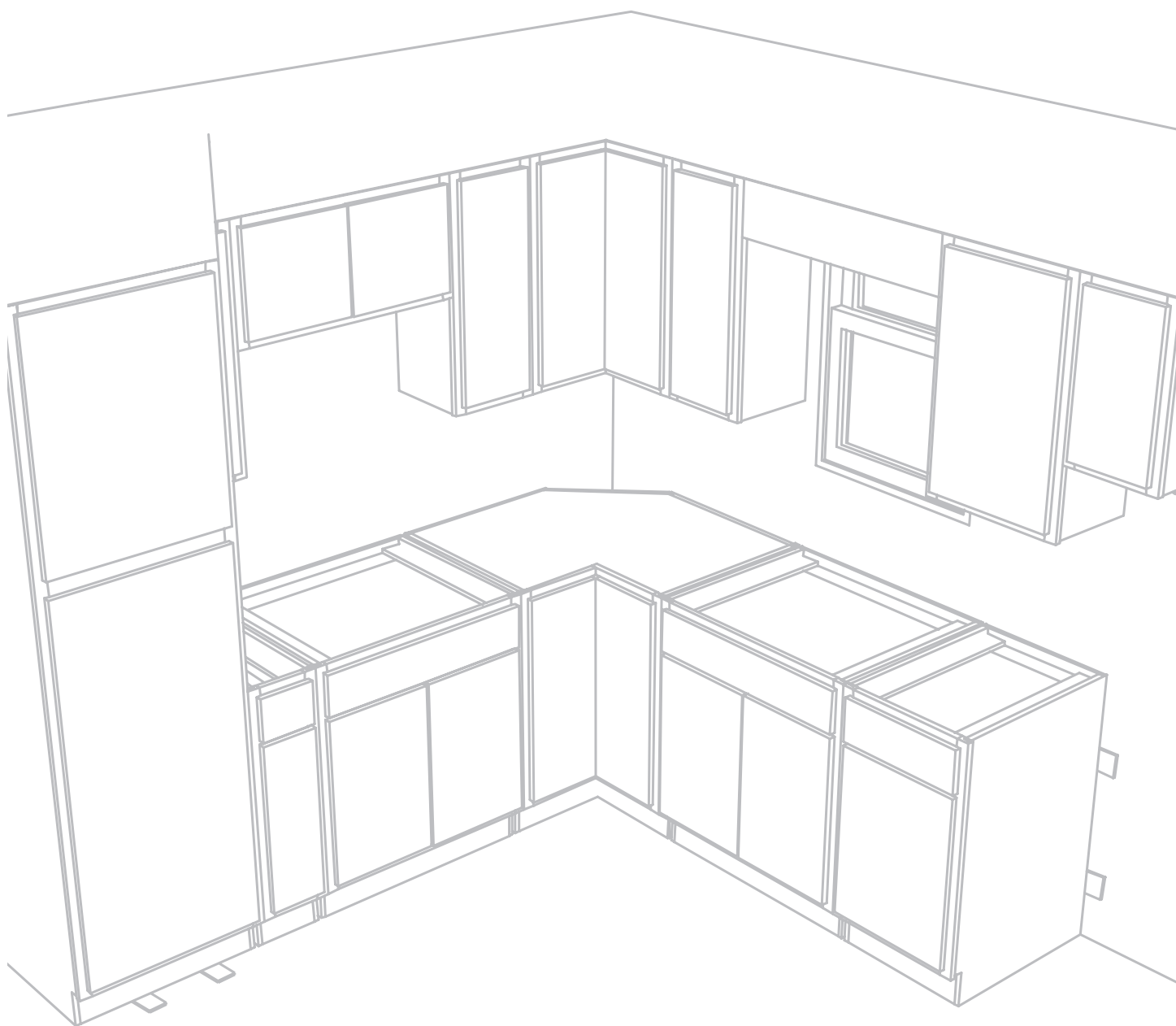

STARMARK
C A B I N E T R Y

INSTALLATION EQUIPMENT

#8 x 2½" screws	Small carpenter's saw or jigsaw
#8 x 2½" washer head screws	Electric or hand planer
Variable speed drill, electric or cordless	Scribing tool and pencil
Extension cord	Utility knife
Countersink drill bit	Chalk line
Drill bits, 3/16" and 1/4"	Stud finder
Assorted screwdriver bits	Patching plaster and putty knife
Phillips and flat screwdriver	Sandpaper
Stepladder	Cedar shakes, shingles or other suitable tapered pieces of wood for shims
Two 6" bar clamps or "C" clamps	Finishing nails
Steel tape measure	Putty Stick and Touch Up Pen
Carpenter's square	Soft cloth
Carpenter's level at least 24" in length	Painter's tape
Claw hammer	

!! ALWAYS USE SCREWS, NEVER NAILS, TO INSTALL STARMARK CABINETRY. USING NAILS VOIDS THE WARRANTY.

DEFINITIONS

Base Cabinets

The lower set of cabinets that rest on the floor.

Baseline

The horizontal line used as a reference point for measuring and placing base and wall cabinets. The baseline will be either the floor, or a line on the wall corresponding to the high point on the floor.

Level

Alignment along a true horizontal line. If something is "out of level" it is not horizontal.

Plumb

Alignment along a true vertical line. If something is "out of plumb" it is not vertical.

Rail

A horizontal framing member of a cabinet.

Shim

A thin wedge of wood for driving between cabinets and walls to plumb cabinets, and for driving between cabinets and floor to level cabinets.

Soffit

An enclosed space between the top of the wall cabinets and ceiling.

Starter hole

A small hole drilled to facilitate the insertion of a screw. A starter hole has a slightly smaller diameter than the diameter of the screw.

Stile

A vertical framing member of a cabinet.

Stud

An upright framing member of a wall or partition. Typically these are 2x4 and are spaced 16" on center.

Wall Cabinets

The upper set of cabinets which are mounted to the wall, ceiling or soffit.

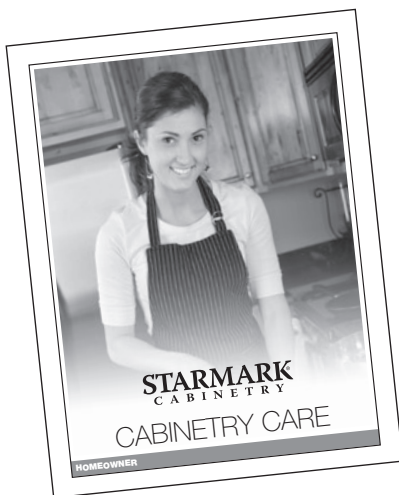
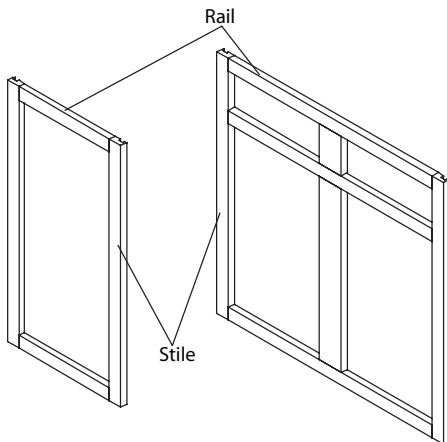

HOMEOWNER INFORMATION

In addition to this Installation brochure, we've enclosed a Homeowner Help Sheet. Please leave the Homeowner Help Sheet in a spot that the homeowner is sure to see.

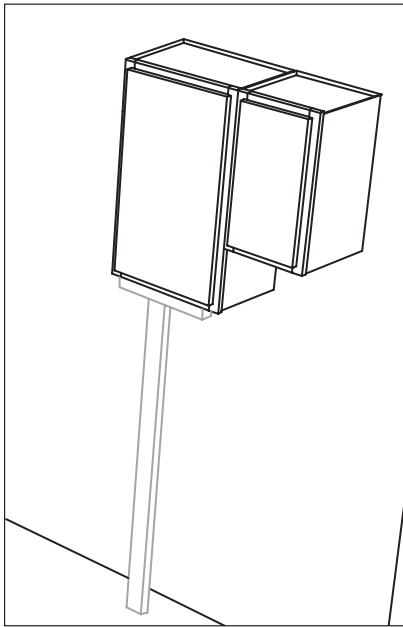
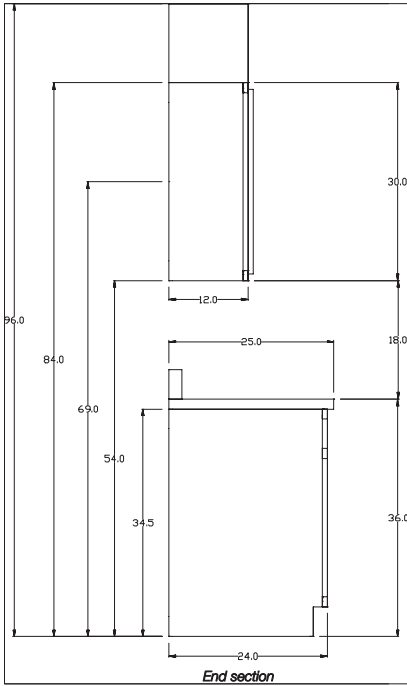

If you are working alone, improvise a T-support from two sections of 2x4. Pad with carpet scraps or soft cloth to prevent scratches. Use this to prop the front side of the cabinet to the proper height while you install screws.

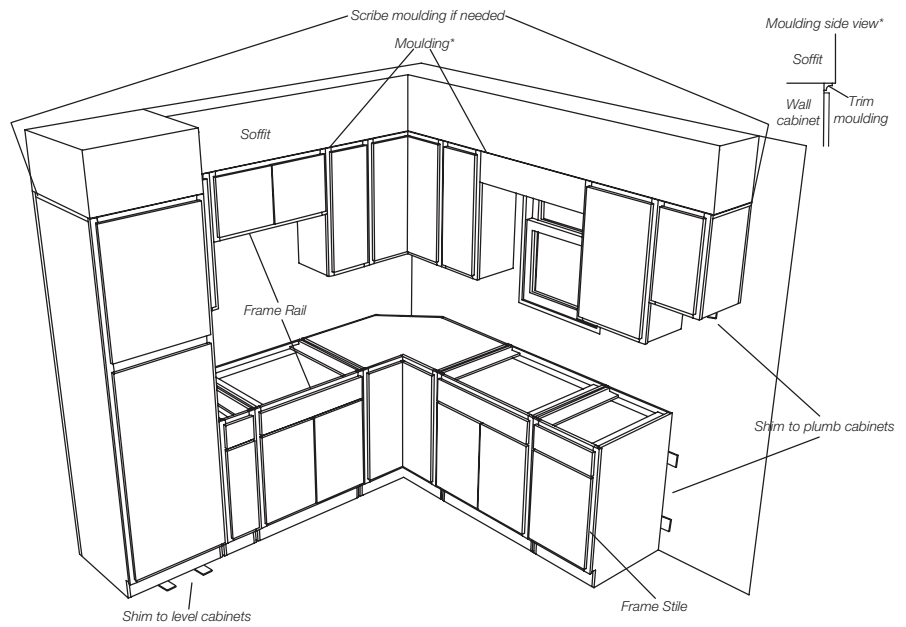

BEFORE YOU BEGIN

- Screws provide stronger, safer installation than nails. **The use of nails to install StarMark Cabinetry voids all guarantees, written or implied.** Nails could allow heavy cabinets to pull away from the wall, causing damage and injury. Order Installation Screws from StarMark (block 12905), or use #8 x 2½" screws, available at hardware or home improvement stores.
- Plaster or wallboard alone is not strong enough to support the cabinets. **All screws must be firmly driven into wall studs.**
- If the kitchen has a soffit, the bottom of the soffit should be:
 - at least 84½" from the baseline
 - not more than 84¾" from the baseline.

This height allows for an 84" high cabinet to be installed, and any gap between the cabinet and soffit can be finished with trim moulding.

- If you are working alone, improvise a T-support from two sections of 2x4. Pad with carpet scraps or soft cloth to prevent scratches. Use this to prop the front side of the cabinet to the proper height while you install screws.
1. Remove old cabinets, if any. Existing woodwork may also need to be removed.
 2. Consult a professional plumber or electrician to disconnect appliances.
 3. Complete any installation of new electrical outlets and plumbing prior to cabinet installation.
 4. Repair cracks and holes with patching plaster. When dry, sand to level any obvious high spots.
 5. Gather the necessary tools and equipment.
 6. Remove doors and drawers. Cabinets are easier to handle when doors are removed. Doors that are left on during installation can swing open, damaging the doors and hinges. As you remove them, use painter's tape to number the doors and drawers on the back to correspond to the cabinets to ensure that you can return them to the proper cabinet.
 7. Remove shelves to avoid damage during the installation process. **Always check the top of each wall and base cabinet, as shelves may be stored in the cabinet's top recess for safe shipping.**
 8. Locate the Putty Stick and Touch Up Pen and set aside in a safe place.

REVIEW THE FLOOR PLAN

StarMark Cabinetry has many modifications and products that make installation easier. Check with the StarMark Cabinetry dealer to find out if the install includes the following features.

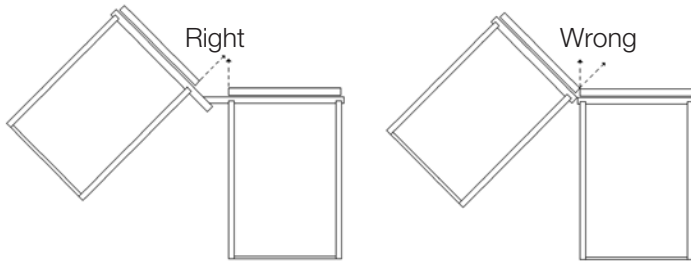

To ensure proper drawer function, use extended stiles or fillers when cabinets are installed at angles to one another.

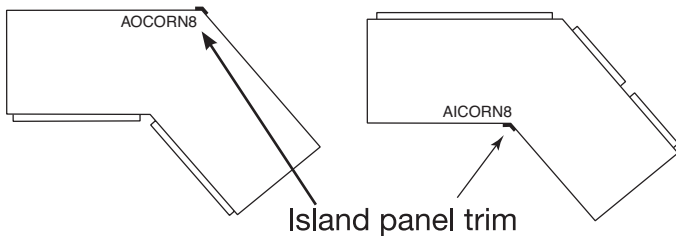

To save time, you can square fit panels together (instead of mitering the joint) and pin AICORN8 (block 10205) or AOCORN8 (block 10207) moulding over the seam to give the same professional finished look as a mitered joint.

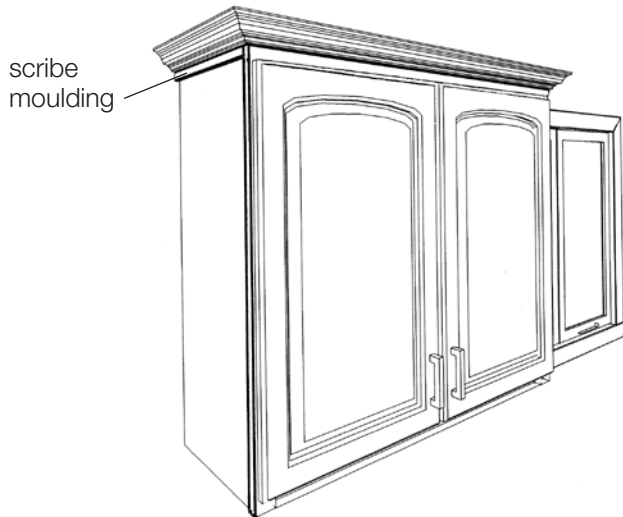

It's time consuming to notch moulding around the frame. There are two ways to eliminate this work.

1. Use scribe moulding (FLAT, block 10210) to flush out the reveal that exists where the end panel and face frame meet.
2. The dealer may have specified Flush Ends (block 12070) or Furniture Ends (block 12065).

This area is enlarged below.

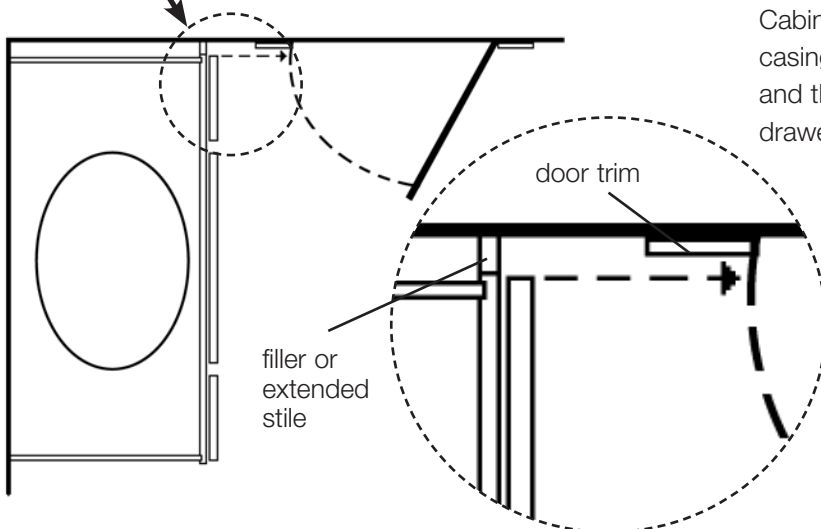

Cabinetry, especially bathroom vanities, installed near door casings may need a filler installed between the cabinet and the wall to ensure proper clearance for the doors and drawers.

A filler, extended stile or wide stile will prevent a drawer from opening into the door trim.

This situation occurs most frequently with Full International door styles and in small, close installations, such as baths.

PREPARE THE INSTALLATION AREA

1. **For full support, you *must* attach cabinets to wall studs.** Find studs using a stud finder, or by tapping the wall lightly with a hammer until you find a spot that does not sound hollow. Prove the spot by driving a nail into the wall until you locate the center of the stud. Studs are usually 16 inches apart on center. Mark vertical lines to identify each stud in the installation area.
2. Find your baseline. Many floors are not level, so use your level to examine the floor in the installation area. If it has obvious high points, use the highest point to determine the horizontal plane on which the cabinets will be installed. Transfer a mark to the wall at the height of the high point on the floor. Extend this line with a level and pencil or a chalk line throughout the installation area. This is the “baseline”.
3. Measure 34½” up the wall from the baseline. Draw a horizontal line using a carpenter’s level and pencil or a chalk line. This will be the top height of your base cabinets. As you install, shim the base cabinets to this line at the back, and use a level as you shim the front edge as needed.
4. The space between the finished countertop and the bottom of the wall cabinet is typically 18”. This may vary based on individual preference and accessibility. Use a level to mark a horizontal line at the appropriate height for the top of the cabinets used in your installation. See chart below for standard top heights.

Wall cabinet height	Top height from baseline
30”	84”
36”	90”
42”	96”

5. To assist you in installing and leveling wall cabinets, mount the top edge of a 1x2 board 54” up from the baseline. Nail the board to the studs. When installing cabinets, place the bottom of the cabinet on the 1x2 board, shim, and fasten cabinet to the wall. Remove board after cabinets are fastened. Patch holes.

!! ALWAYS USE SCREWS, NEVER NAILS, TO INSTALL STARMARK CABINETRY. USING NAILS VOIDS THE WARRANTY.

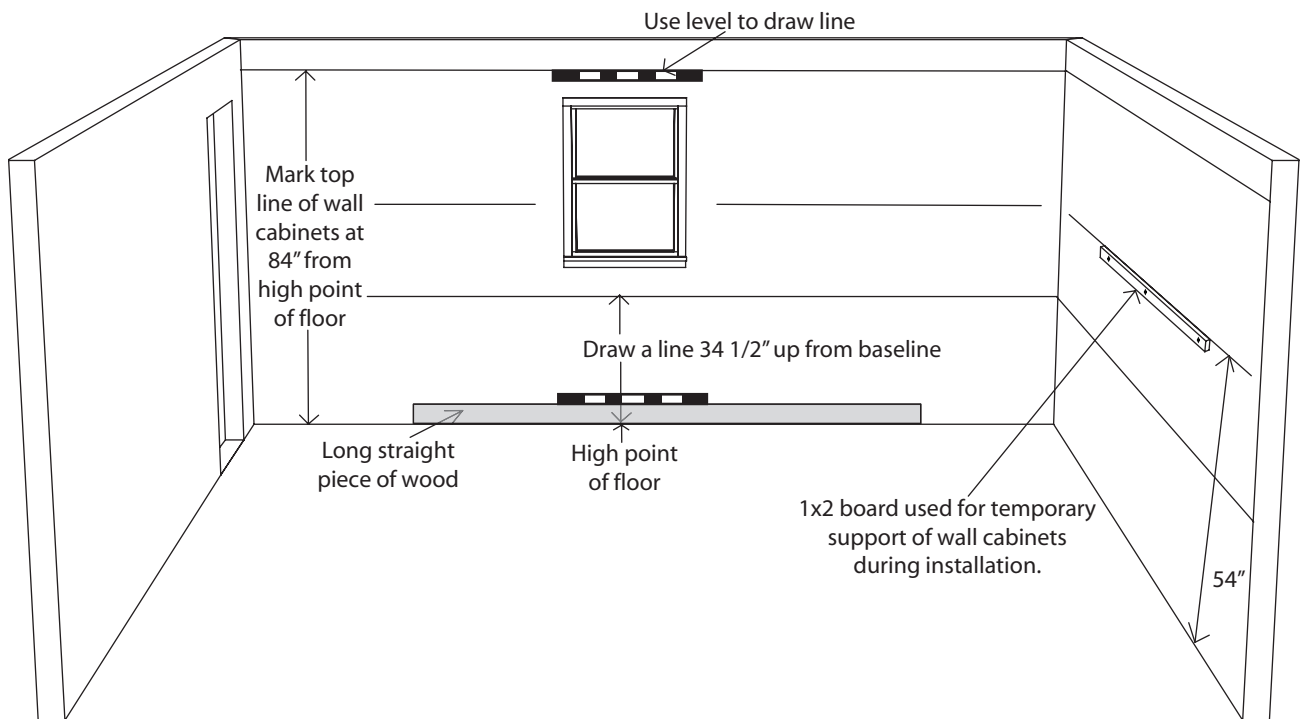
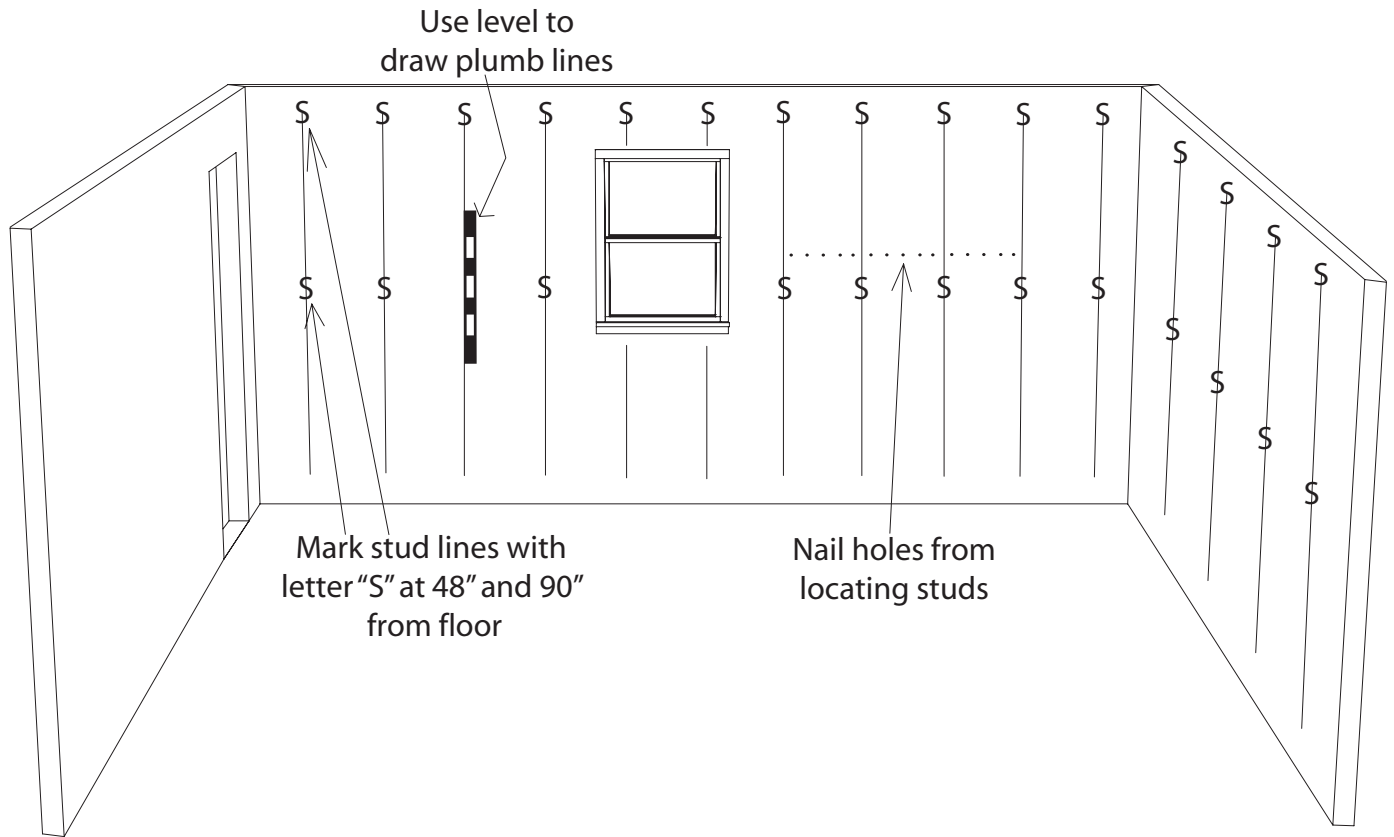

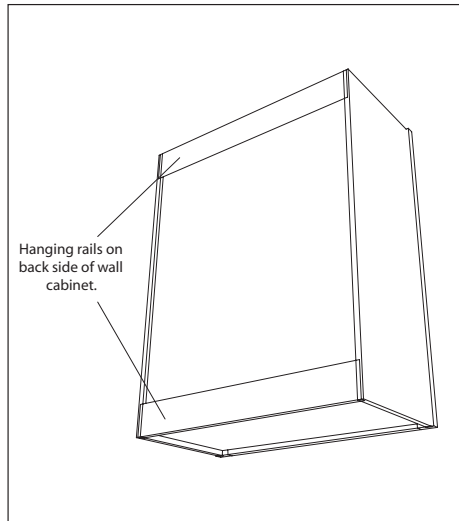

Use at least two #8 x 2 1/2" screws through the hanging rail of the cabinet. Attach only loosely at first, to allow for necessary adjustments.

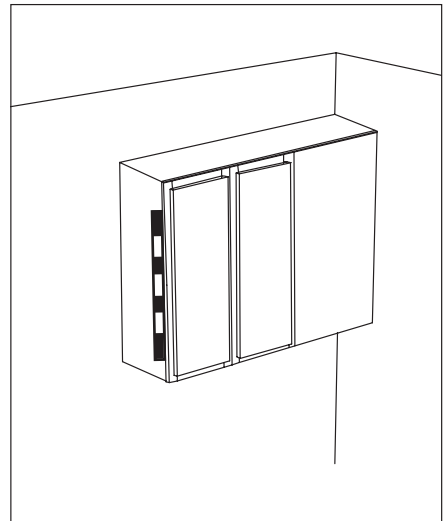

Check alignment of cabinets with a carpenter's level on front, sides and bottom.

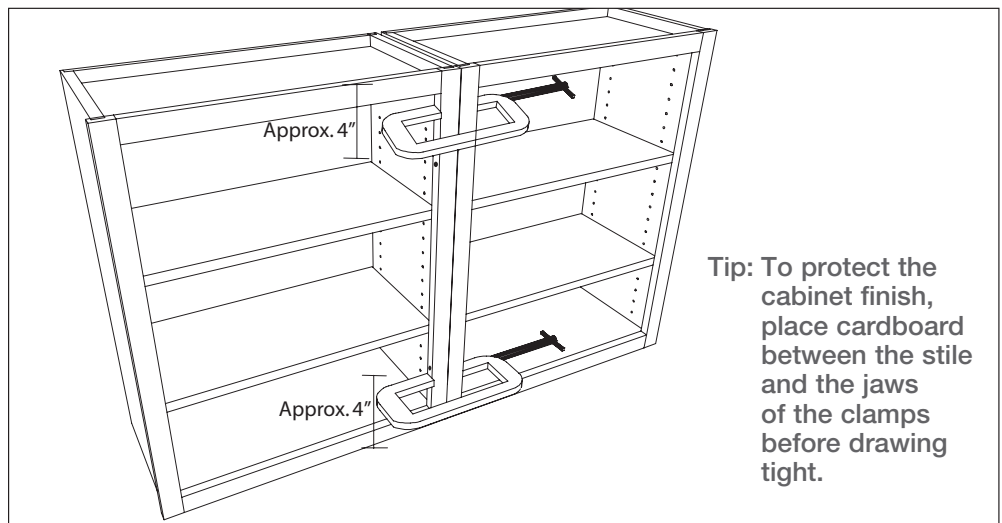

Tip: To protect the cabinet finish, place cardboard between the stile and the jaws of the clamps before drawing tight.

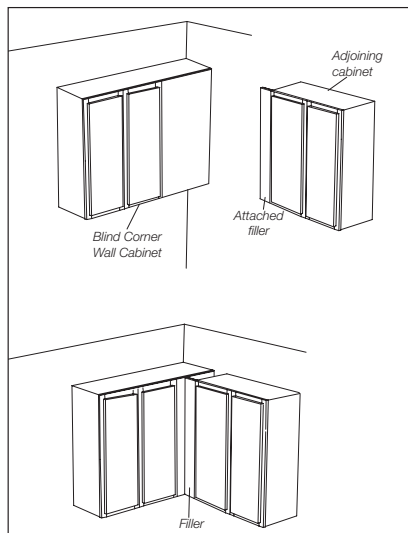

Tip: For a custom fit, you can adjust blind corner cabinets in both directions. First, install the corner cabinet and all other wall cabinets on the same wall. Next, cut filler to width and length as needed in the same manner as described for attaching one unit to the next. Last, install adjoining cabinet with filler attached.

INSTALL WALL CABINETS

Experienced installers recommend that wall cabinets be installed first.

1. If you are using filler strips, they should be attached to the cabinet before you install the cabinet. Clamp filler into place on the cabinet stile. Use a countersink bit to drill a starter hole and attach with screws.
2. Start with a corner unit. Pre drill the backs and hanging rails of the cabinet. Be sure all screws will be driven into studs.
3. Use at least two #8 x 2½" screws through the hanging rail of the cabinet. Attach only loosely at first, to allow for necessary adjustments. Check alignment of cabinets with a carpenter's level on front, sides and bottom. Shim the back edges of the cabinet as necessary. Tighten screws.

Tip: Inset cabinetry must be properly shimmed to maintain door alignment with face frame. The tight reveals around the doors and the small adjustment in the hinges magnifies any racking that may occur if an inset cabinet is not shimmed correctly.

4. Position an adjoining wall cabinet next to the first one you installed. Use bar clamps to draw the stiles together securely near the upper and lower hinges. Shim and secure the second cabinet to the wall loosely as before, making sure the stiles line up with each other at the front.
5. About 4" from top and 4" from bottom, use a countersink bit to drill starter holes completely through one stile and about 1/4" into the other. Secure stiles with screws, making sure that the length of screw used doesn't exceed the combined width of the two stiles. Tighten screws into wall studs.

Tip: The screws driven into the stiles of inset cabinetry must be countersunk so the doors will operate. One way to conceal these screws is to install them so the hinge will cover them. However, make sure you don't place them where the hinge screws need to go.

6. Wall cabinets above a peninsula or island must hang from the ceiling or soffit. Use **at least** one #8 washer head screw every 16". These screws must have **at least** 1½" penetration into solid wood ceiling joists or soffit frames. Pre drill 3/16" starter holes in the front frames.

!! ALWAYS USE SCREWS, NEVER NAILS, TO INSTALL STARMARK CABINETY. USING NAILS VOIDS THE WARRANTY.

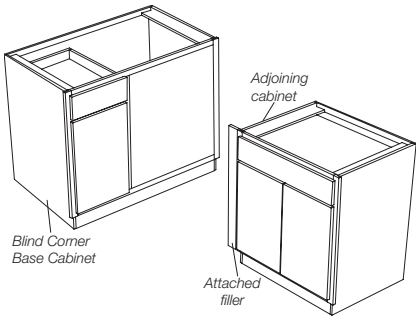

INSTALL BASE CABINETS

Base cabinets are installed similar to wall cabinets.

1. If you are using filler strips, they should be attached to the cabinet before you install the cabinet. Clamp filler into place on the cabinet stile. Use a countersink bit to drill a starter hole and attach with screws.
2. Start with a corner base cabinet and add cabinets to each side. As each cabinet is installed, make certain that the fronts are plumb and level. Attach cabinets loosely at first so you can make adjustments. Use shims to adjust cabinets as necessary to level line and to compensate for uneven walls.
2. Fasten the front stiles together before fully tightening screws to wall studs.
4. If base cabinets are installed on either side of a lazy susan, fasten them together as a unit and then install, shimming where necessary. Make sure the the lazy susan base operates properly before you attach more cabinets.

Tip: To support the countertop in a corner above a lazy susan base (block 3320), attach strips of 1x2 to the wall and level with the height of the cabinet tops.

5. For peninsula or island installation, trace the cabinet footprint on the floor and secure blocks to floor along this line under the cabinet. Fasten the cabinet to the blocks.
6. Before installing a sink base cabinet, use a jigsaw or hole saw to cut an opening for the plumbing. Measure your water and drain line for the proper dimension of the openings. You may also need an opening for an electrical outlet for a garbage disposal.

Tip: For a custom fit, you can adjust blind corner cabinets in both directions. First, install the corner cabinet and all other base cabinets on the same wall. Next, cut filler to width and length as needed in the same manner as described for attaching one unit to the next. Last, install adjoining cabinet with filler attached.

Tip: Inset cabinetry must be properly shimmed to maintain door alignment with face frame. The tight reveals around the doors and the small adjustment in the hinges magnifies any racking that may occur if an inset cabinet is not shimmed correctly.

Tip: The screws driven into the stiles of inset cabinetry must be countersunk so the doors and drawers will operate. One way to conceal these screws is to install them so the hinge will cover them. However, make sure you don't place them where the hinge screws need to go.

Tip: Decorative hardware can project out, preventing a drawer from opening properly. Always check the projection of decorative hardware to see if you need to install a filler for proper drawer operation.

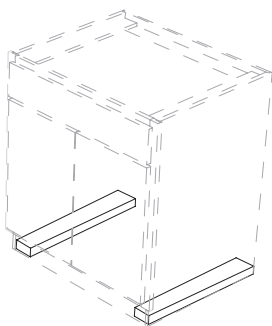
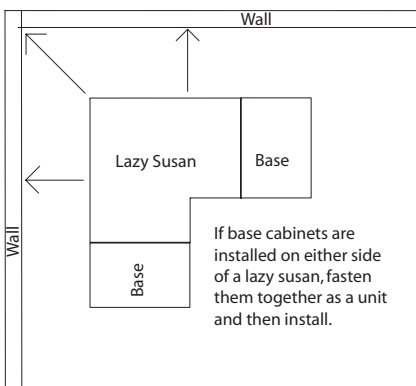

For peninsula or island installation, trace the cabinet footprint on the floor and secure blocks to floor along this line under the cabinet. Fasten the cabinet to the blocks.

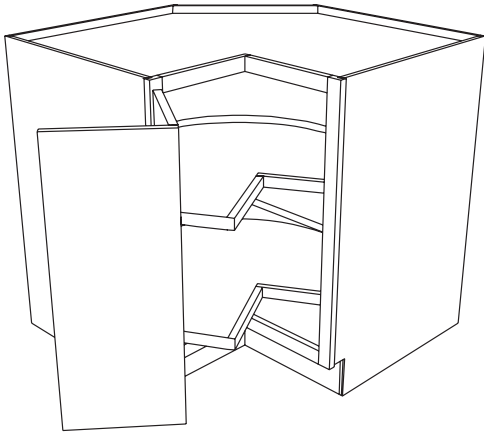

Most lazy susan cabinets have side and end panels, so no extra countertop support is necessary.

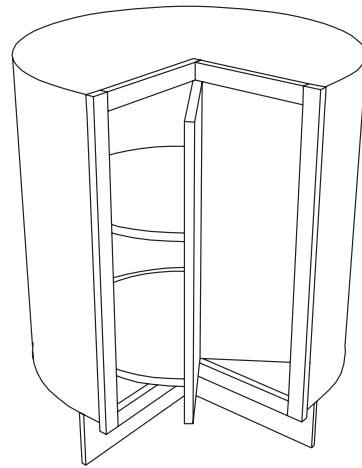

Just one lazy susan base (block 3320) doesn't have side or end panels. To support the countertop in a corner above this lazy susan base, attach strips of 1x2 to the wall and level with the height of the cabinet tops, as shown below.

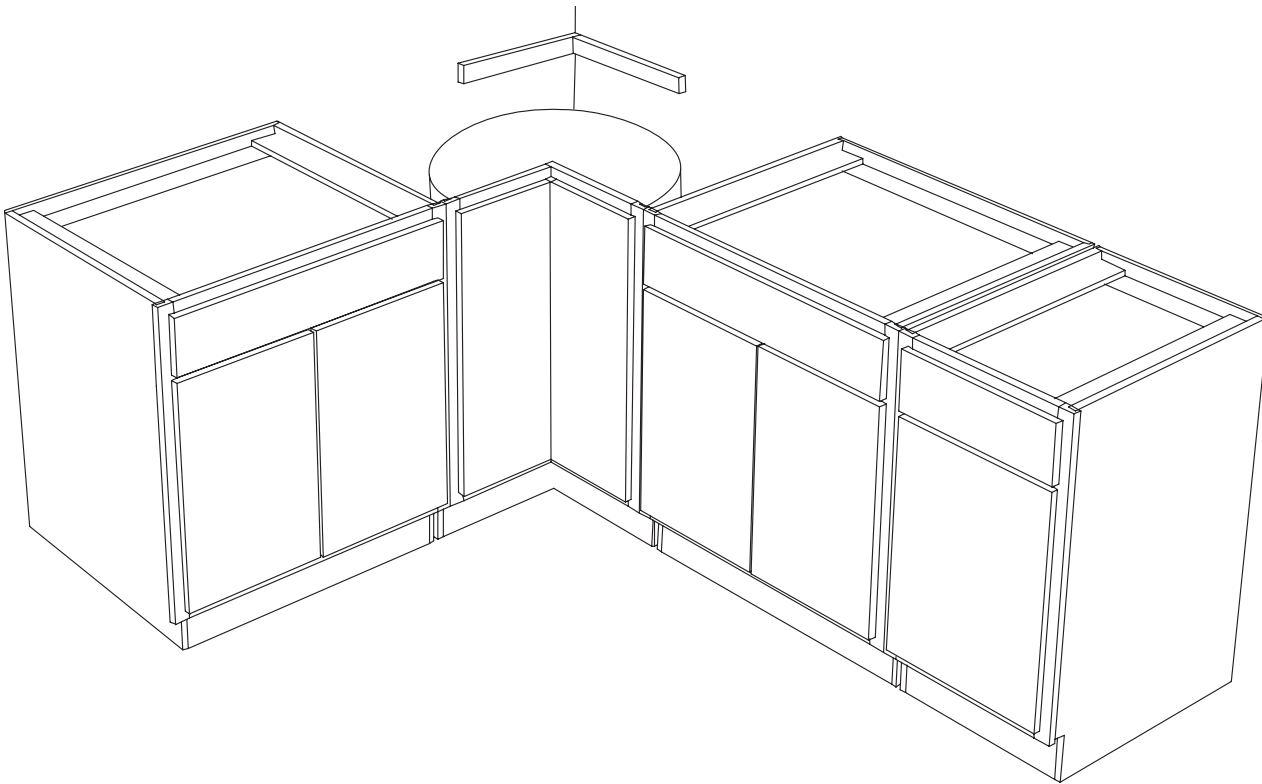

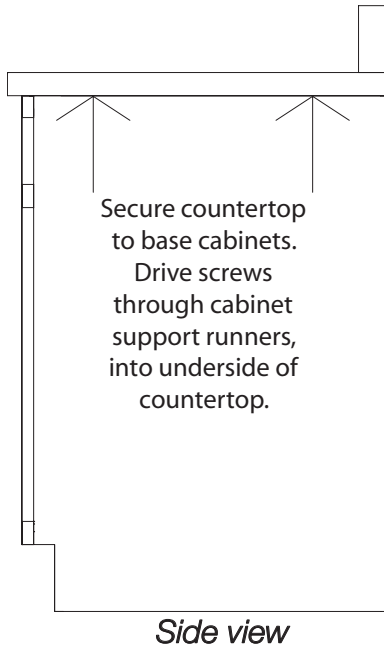

FINISHING

Using a level, confirm that all cabinets are level and plumb. Any final adjustments should be made at this time. Confirm that all screws are tight.

Install valances.

Measure the space where the valance will go. Trim the valance to size and install by screwing through the face frames of the adjoining cabinets.

Install toe board trim.

Cut to length and fasten with small finishing nails. Fill holes with Putty Stick (block 12910) and buff with a soft cloth.

Install countertops.

Have countertop measurements taken by a countertop professional after the base cabinets have been installed. This will allow compensation for any walls that are not square, and ensure a professional appearance and fit.

A countertop thickness of 1½" brings the base cabinets to a standard height of 36".

Select a screw length that will fasten the countertop to the cabinet support without protruding through the top.

Attach countertop to base cabinets by first drilling starter holes upward through the support runners into the underside of the countertop. Attach with screws.

Re-attach doors to the proper cabinets and adjust door hinges.

Hinges may need to be adjusted to correct alignment. See page 11 for inset instructions, and page 12 for overlay instructions.

Install drawers and adjust the drawer headers.

Before attaching decorative hardware, adjust the drawer headers. See page 11 for inset instructions, and page 12 for overlay instructions.

Install shelves.

Install shelf clips so the weight of the shelf rests on the shelf supports. On a double door cabinet, install shelf clips in the center of the cabinet to prevent sagging.

Install trim.

In a kitchen without a soffit, use crown moulding or other millwork to finish the top edge of the cabinets. Attach with small finishing nails. Fill holes with Putty Stick (block 12910) and buff with a soft cloth.

If there is a soffit, use trim moulding to conceal gaps between the soffit and cabinets with small finishing nails. Fill holes with Putty Stick (block 12910) and buff with a soft cloth.

Use scribe moulding to conceal gaps between cabinets of varying depths, and on end cabinets at the wall. Attach with small finishing nails. Fill holes with Putty Stick (block 12910) and buff with a soft cloth.

Install hardware.

Install door and drawer hardware according to manufacturer's instructions. Countersink the screws so they don't scratch the cabinet face frame.

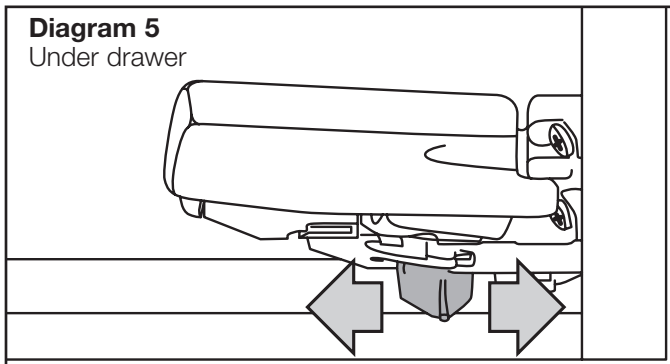
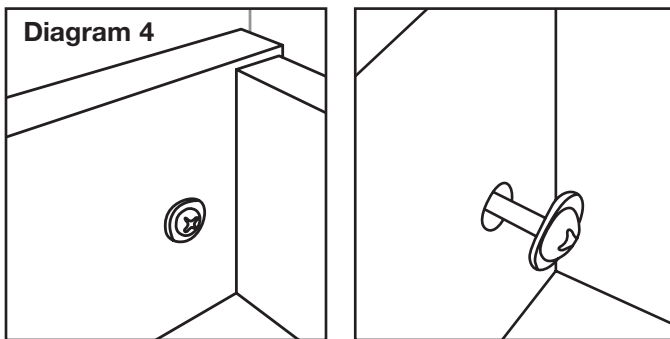
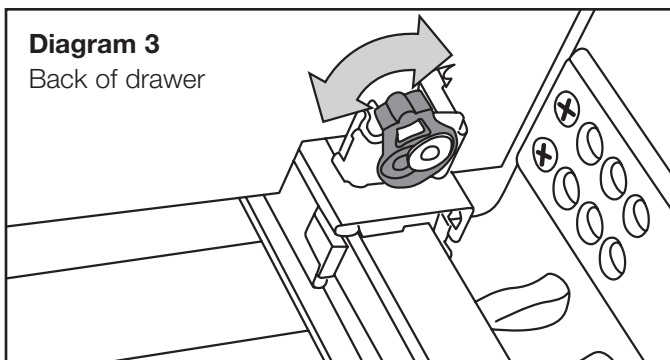
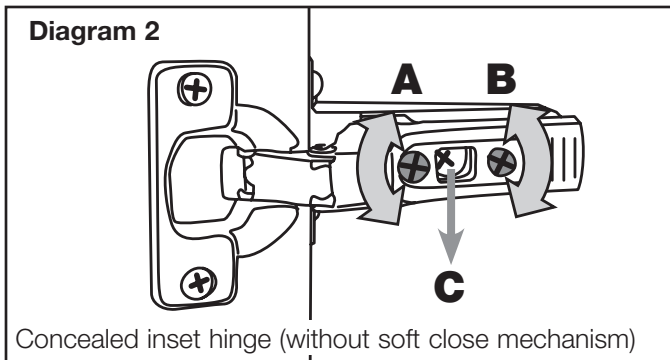
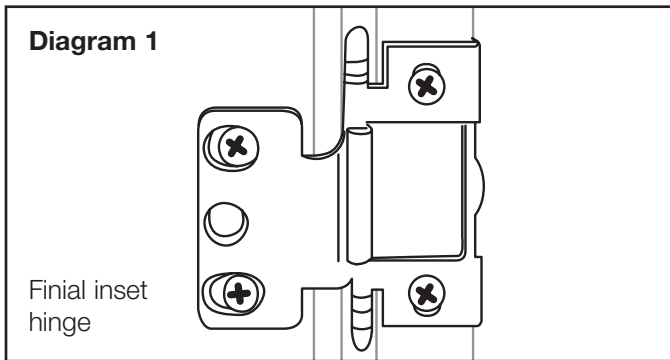

INSET DOOR HINGE AND DRAWER ADJUSTMENT

DOORS

1. After the cabinets are installed, square the doors to the door opening using a Phillips screwdriver to adjust the hinges. **Diagram 1** shows the four screws you can use to adjust finial hinges.
2. To adjust concealed hinges, see **Diagram 2**. Turn Screw A (the screw closest to the door) to move the door left and right in the door opening. Turn Screw B (the screw furthest back in the cabinet) to move the door forwards and back. Turn Screw C to move the door up and down. Be aware, the moves will be small.

If the cabinet doors are equipped with soft close, you will have to remove the soft close mechanism (it has a gray plunger) before you can adjust hinges. Remove it by sliding it toward you. Replace it after adjusting the hinges.

DRAWERS

After the cabinets are installed but before the decorative hardware is attached, adjust the drawer headers. There are three ways to do this.

3. **Adjust the undermount glides (Diagram 3).** There is a cam at the back of the drawer that can be rotated back and forth. This will move the back of the drawer up or down, thereby adjusting how flat the drawer front will sit with the face of the cabinet.
4. **Adjust the screws that hold the drawer front to the drawer box (Diagram 4).** These screw holes are oversized to allow vertical and horizontal adjustment. You do not need to remove the drawers to adjust the tracks.
5. **A vertical-only adjustment can be made using the sliding tab under the drawer box (Diagram 5).** The lever is very sensitive and makes very minute adjustments.

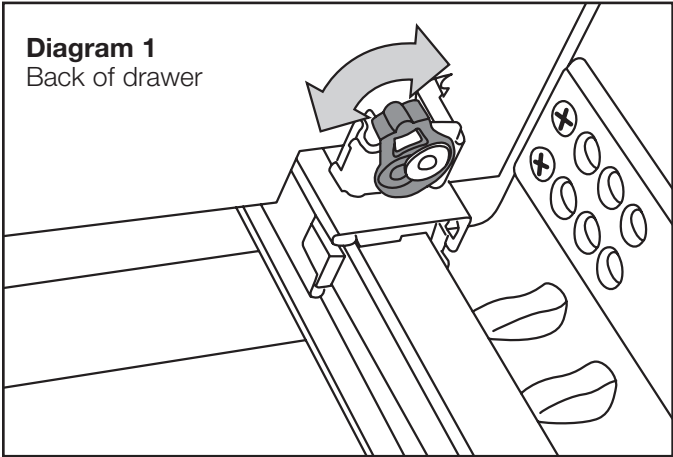

OVERLAY DOOR HINGE AND DRAWER ADJUSTMENT

There are two ways to adjust drawer headers.

There is a cam at the back of the drawer that can be rotated back and forth. This will move the back of the drawer up or down, thereby adjusting how flat the drawer front will sit with the face of the cabinet.

The lever is very sensitive and makes very minute adjustments. Remove doors before installing cabinets. To adjust doors after they've been re-installed, use the two cam screws on each hinge. The screws are protected so you are unable to turn them too far.

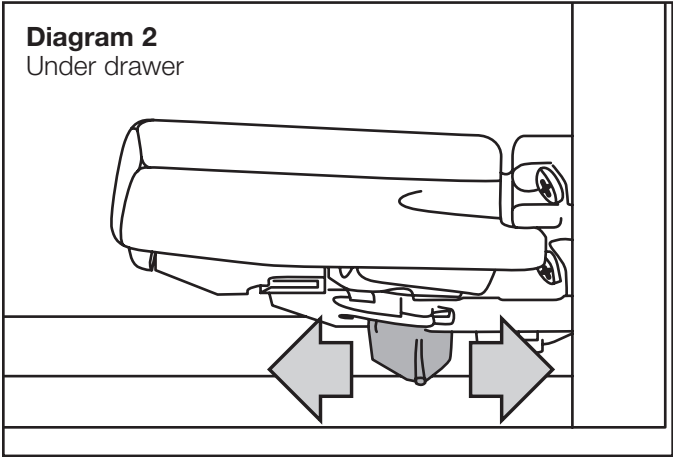

The screw on the outside of the face frame moves that corner of the door left and right bringing the doors straight with each other.

The screw on the inside of the face frame brings that corner of the door forward and back to keep the door flat to the face of the cabinet.

