

TURNTABLE DIAMETER

[599.00in]
15215mm

TURNTABLE HEIGHT

[18.39in]
467mm

DRIVE	480V 3-PHASE 10.0 HP NORD MOTOR & GEARBOX
CAPACITY	26,000LB DISTRIBUTED ACTIVE 52,000LB STATIC DISTRIBUTED 7,500LB POINT LOAD
TOP SURFACE	1/4" DIAMOND TREAD CARBON STEEL POWDERED COATED
STRUCTURE FINISH	PRIMED AND PAINTED
FEATURES	DESIGN FOR A 600" PIT

SERVICE HATCH

TOP SURFACE

DRAWN	E.CONTRERAS	9/23/2015
EXPORTED		9/24/2015



TITLE:			
M152HD Turntable Specification			
CAROUSEL USA 6370 N. Irwindale Ave. Irwindale CA, 91702 TEL: (626) 334-7190 FAX: (626) 236-4060 www.Carousel-USA.com	PROPRIETARY AND CONFIDENTIAL The information contained in this drawing is the sole property of Carousel USA. Any reproduction in part or as a whole without the written permission of Carousel USA is prohibited.	SIZE B	DWG. NO. M152HD--1
		SCALE: 1:60	REV 1
		DO NOT SCALE DRAWING	SHEET 1 OF 7

8 7 6 5 4 3 2 1

PRIMED AND PAINTED STEEL COMPONENTS

D

D

C

C

B

B

A

A

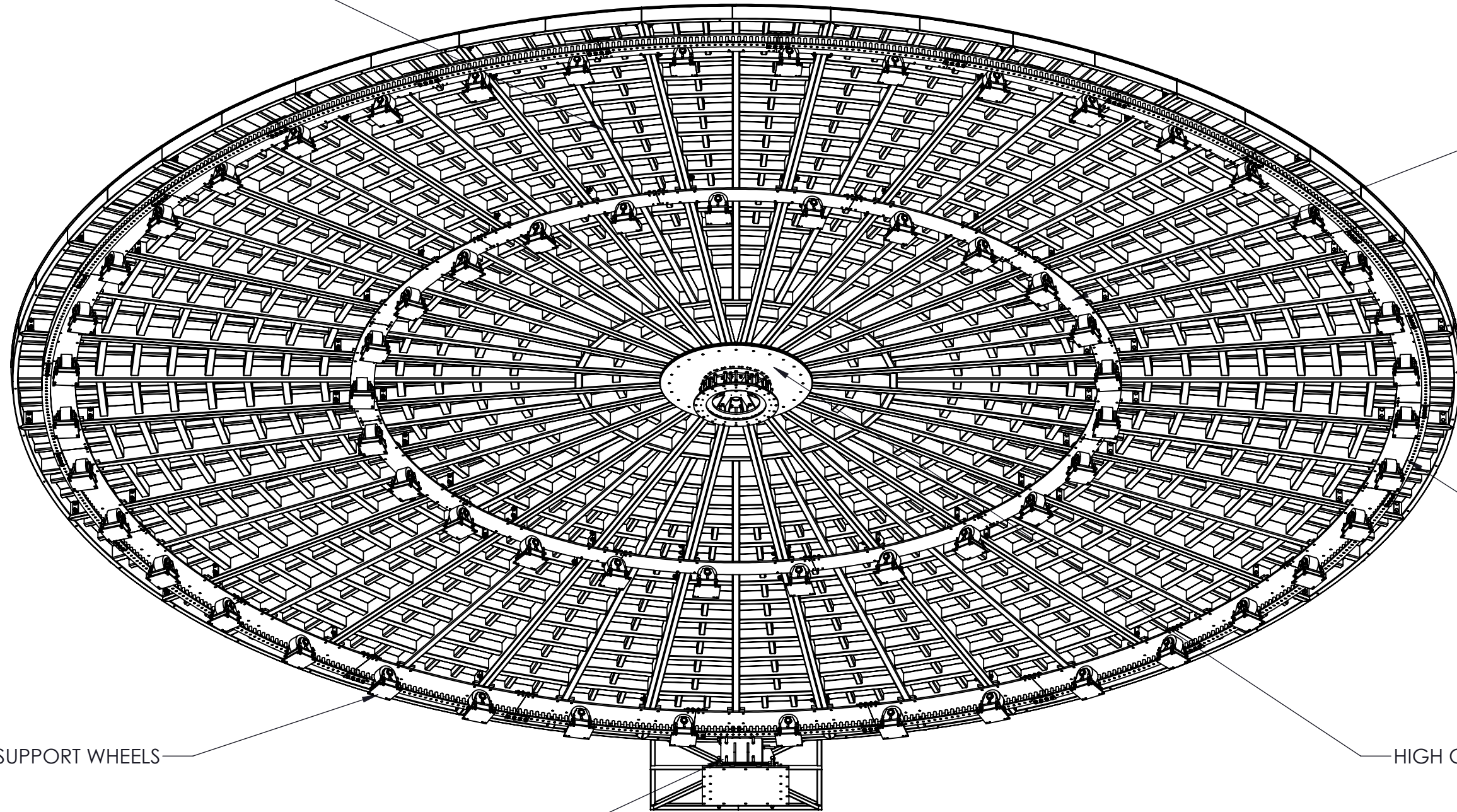

INNER RUNNING RAIL

OUTER RUNNING RAIL

HIGH CAPACITY SUPPORT WHEELS

HIGH CAPACITY CENTER BEARING

NORD MOTOR AND GEARBOX

DRAWN	E.CONTRERAS	9/23/2015
EXPORTED		9/24/2015



TITLE:

**M152HD
Turntable Features**

CAROUSEL USA 6370 N. Irwindale Ave. Irwindale CA, 91702 TEL: (626) 334-7190 FAX: (626) 236-4060 www.Carousel-USA.com	PROPRIETARY AND CONFIDENTIAL The information contained in this drawing is the sole property of Carousel USA. Any reproduction in part or as a whole without the written permission of Carousel USA is prohibited.	SIZE B	DWG. NO. M152HD--2	REV 1
		SCALE: 1:50	DO NOT SCALE DRAWING	SHEET 2 OF 7

8 7 6 5 4 3 2 1

8 7 6 5 4 3 2 1

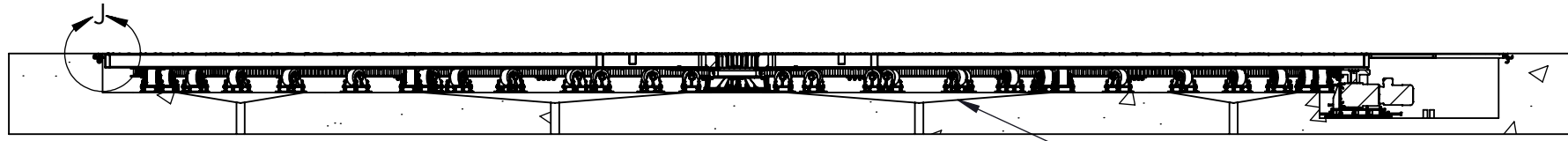

SECTION H-H

OPTIONAL SLOPE WITH DRAINAGE

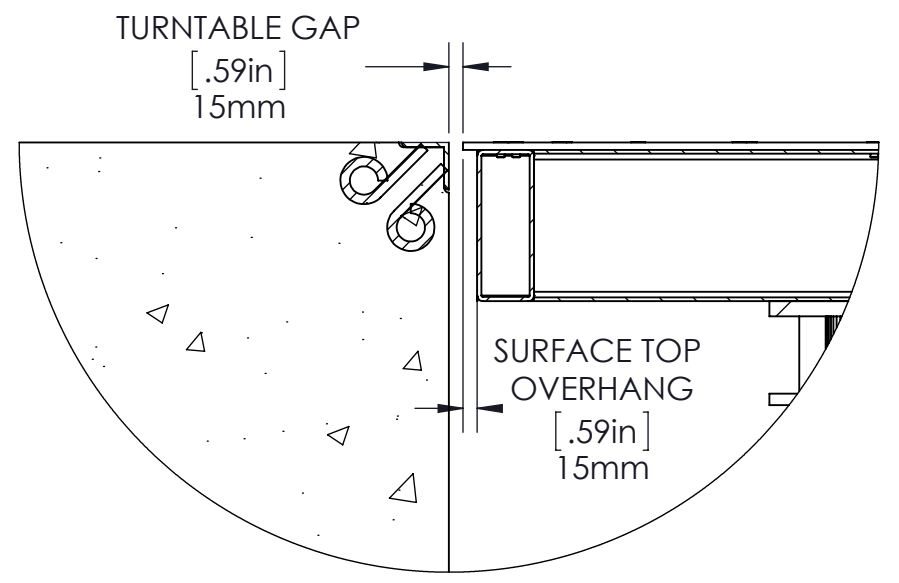

DETAIL J
SCALE 1 : 8

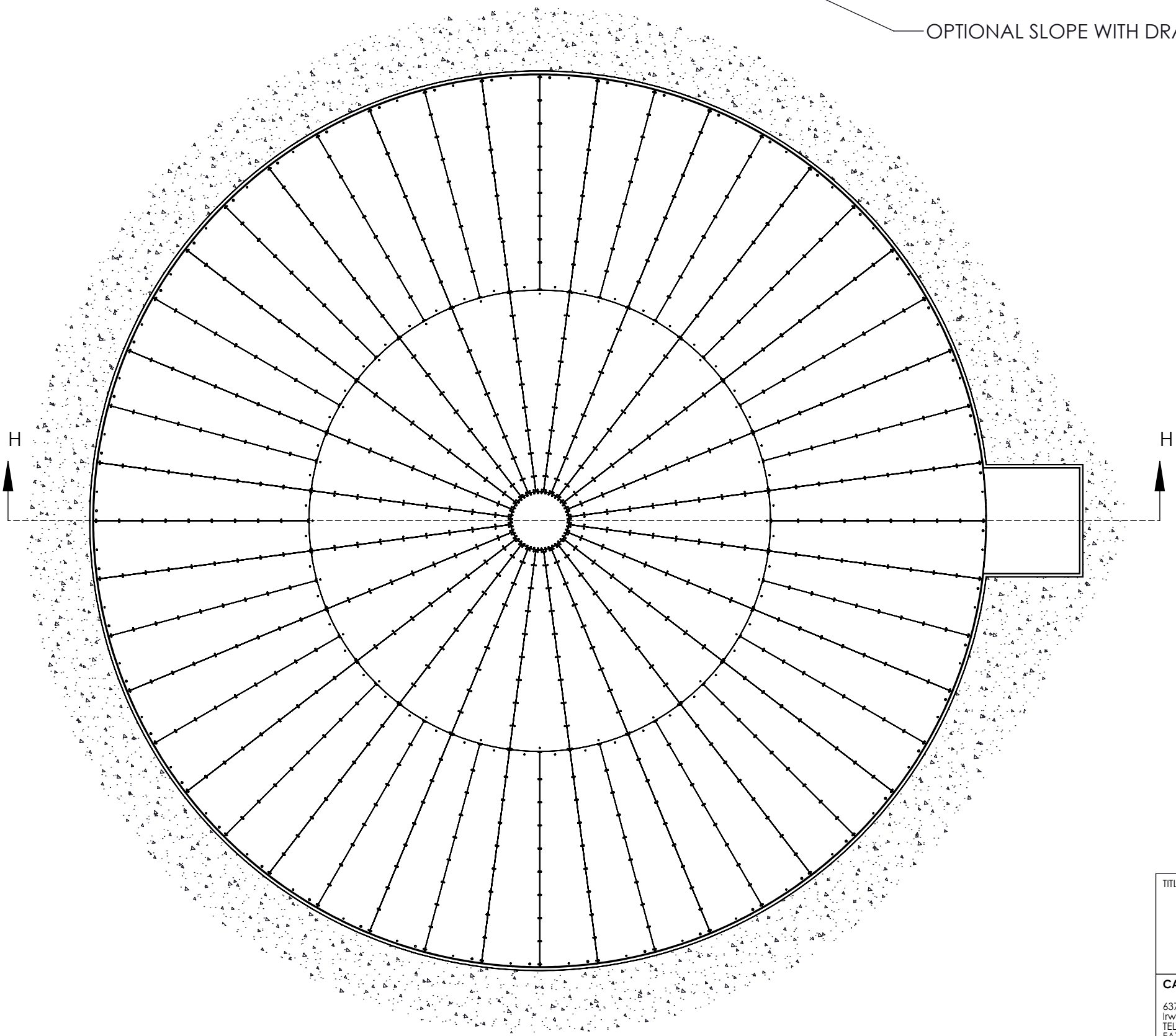

DRAWN	E.CONTRERAS	9/23/2015
EXPORTED		9/24/2015



TITLE:
**M152HD
Turntable In Pit**

CAROUSEL USA 6370 N. Irwindale Ave. Irwindale CA, 91702 TEL: (626) 334-7190 FAX: (626) 236-4060 www.Carousel-USA.com	PROPRIETARY AND CONFIDENTIAL The information contained in this drawing is the sole property of Carousel USA. Any reproduction in part or as a whole without the written permission of Carousel USA is prohibited.	SIZE	DWG. NO.	REV
		B	M152HD--3	1
SCALE: 1:80		DO NOT SCALE DRAWING	SHEET 3 OF 7	

8 7 6 5 4 3 2 1

8 7 6 5 4 3 2 1

OPTIONAL SLOPE WITH DRAINAGE

MOTOR PIT

D

D

C

C

B

B

A

A

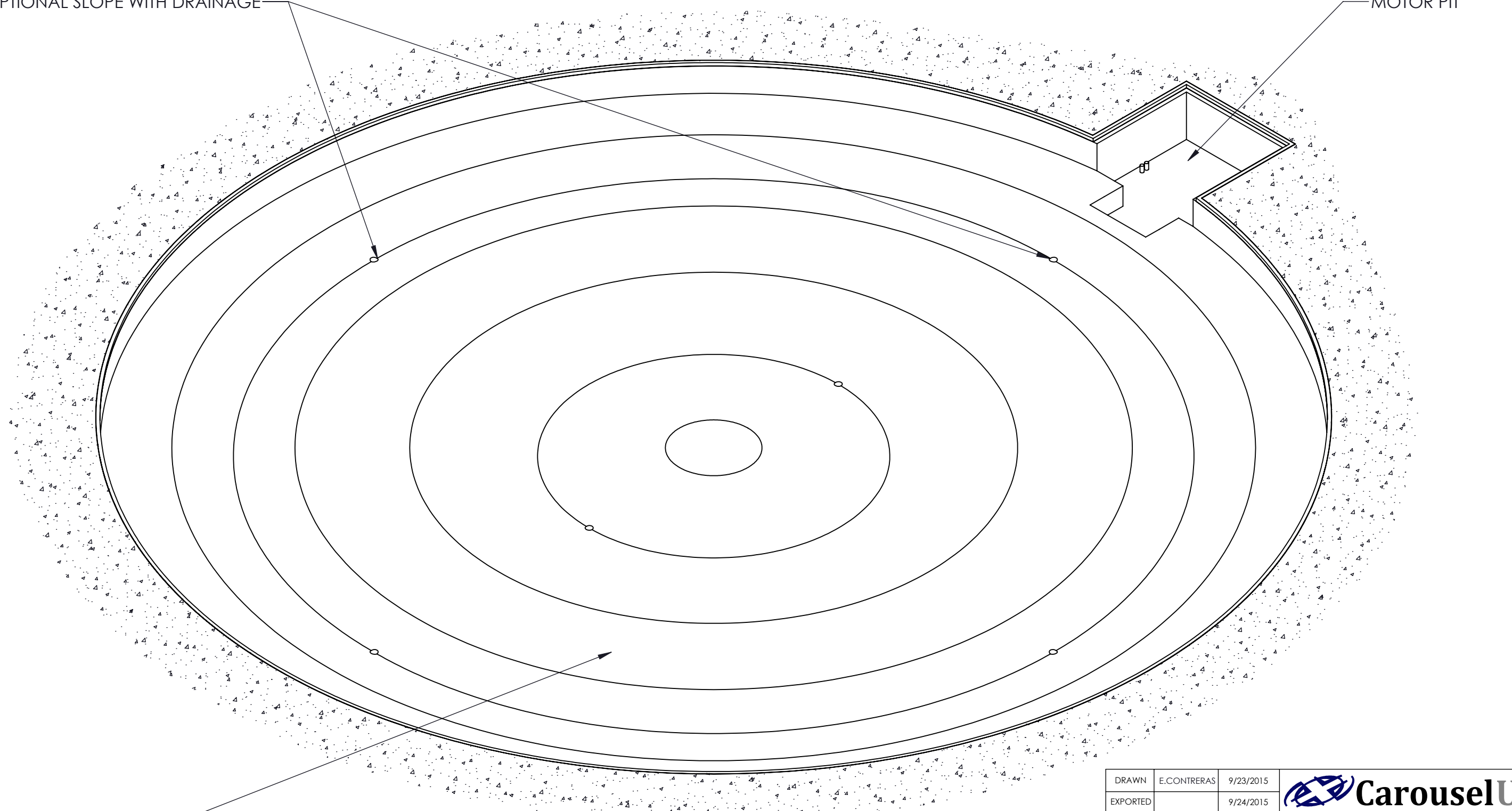

TURNTABLE PIT

DRAWN	E.CONTRERAS	9/23/2015	
EXPORTED		9/24/2015	

TITLE:

M152HD
Concrete Pit Overview

CAROUSEL USA 6370 N. Irwindale Ave. Irwindale CA, 91702 TEL: (626) 334-7190 FAX: (626) 236-4060 www.Carousel-USA.com	PROPRIETARY AND CONFIDENTIAL The information contained in this drawing is the sole property of Carousel USA. Any reproduction in part or as a whole without the written permission of Carousel USA is prohibited.	SIZE	DWG. NO.	REV
		B	M152HD--4	1
SCALE: 1:50		DO NOT SCALE DRAWING	SHEET 4 OF 7	

8 7 6 5 4 3 2 1

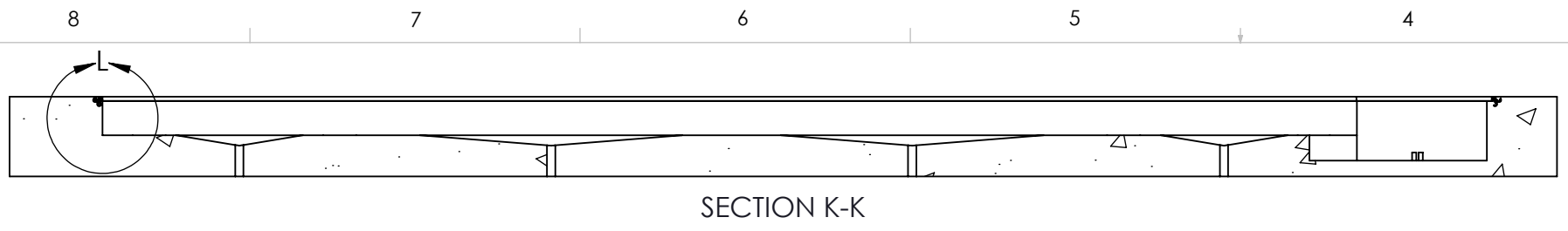

LEVEL SURFACE ID
[297in]
Ø 7550mm
LEVEL SURFACE OD
[410in]
Ø 10400mm

LEVEL SURFACE ID
[529.92in]
Ø 13460mm
LEVEL SURFACE OD
[600in]
Ø 15240mm

LEVEL SURFACE
[47in]
Ø 1200mm

PIT DIAMETER
[600in]
15245mm

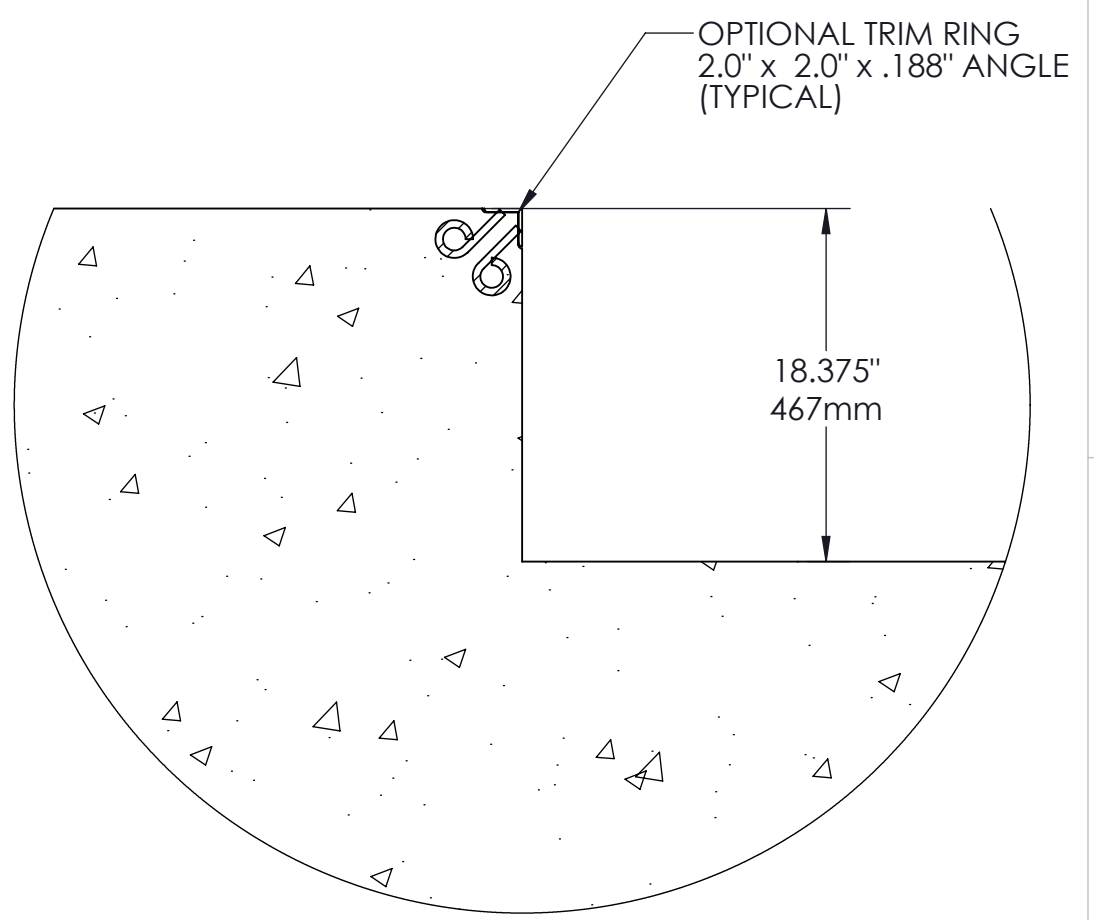

1X CONDUIT FOR 480V 3Ø 10HP MOTOR
(RECOMMEND 1.5" ID)

1X 3/4" CONDUIT
2" AWAY FROM WALL
FOR CONTROLS

DRAWN	E.CONTRERAS	9/23/2015
EXPORTED		9/24/2015



TITLE: M152HD Pit Dimensions			
CAROUSEL USA 6370 N. Irwindale Ave. Irwindale CA, 91702 TEL: (626) 334-7190 FAX: (626) 236-4060 www.Carousel-USA.com	PROPRIETARY AND CONFIDENTIAL The information contained in this drawing is the sole property of Carousel USA. Any reproduction in part or as a whole without the written permission of Carousel USA is prohibited.	SIZE B	DWG. NO. M152HD--5
SCALE: 1:80		DO NOT SCALE DRAWING	REV 1
		SHEET 5 OF 7	

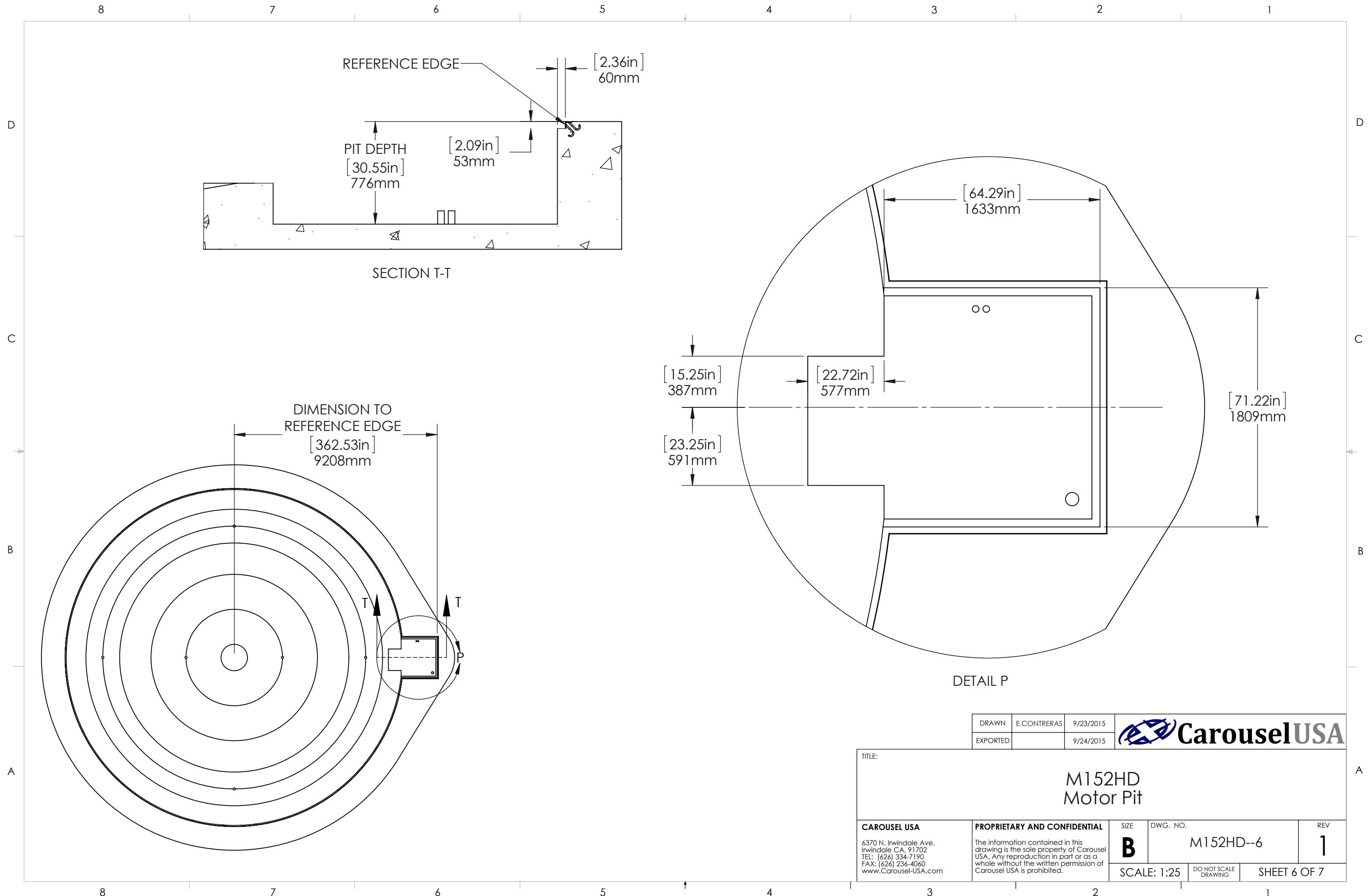

DRAWN	E.CONTRERAS	9/23/2015	
EXPORTED		9/24/2015	

TITLE:			
M152HD Motor Pit			
CAROUSEL USA 6370 N. Irwindale Ave. Irwindale CA, 91702 TEL: (626) 334-7190 FAX: (626) 236-4060 www.Carousel-USA.com	PROPRIETARY AND CONFIDENTIAL The information contained in this drawing is the sole property of Carousel USA. Any reproduction in part or as a whole without the written permission of Carousel USA is prohibited.	SIZE B	DWG. NO. M152HD--6
SCALE: 1:25		DO NOT SCALE DRAWING	REV 1
			SHEET 6 OF 7

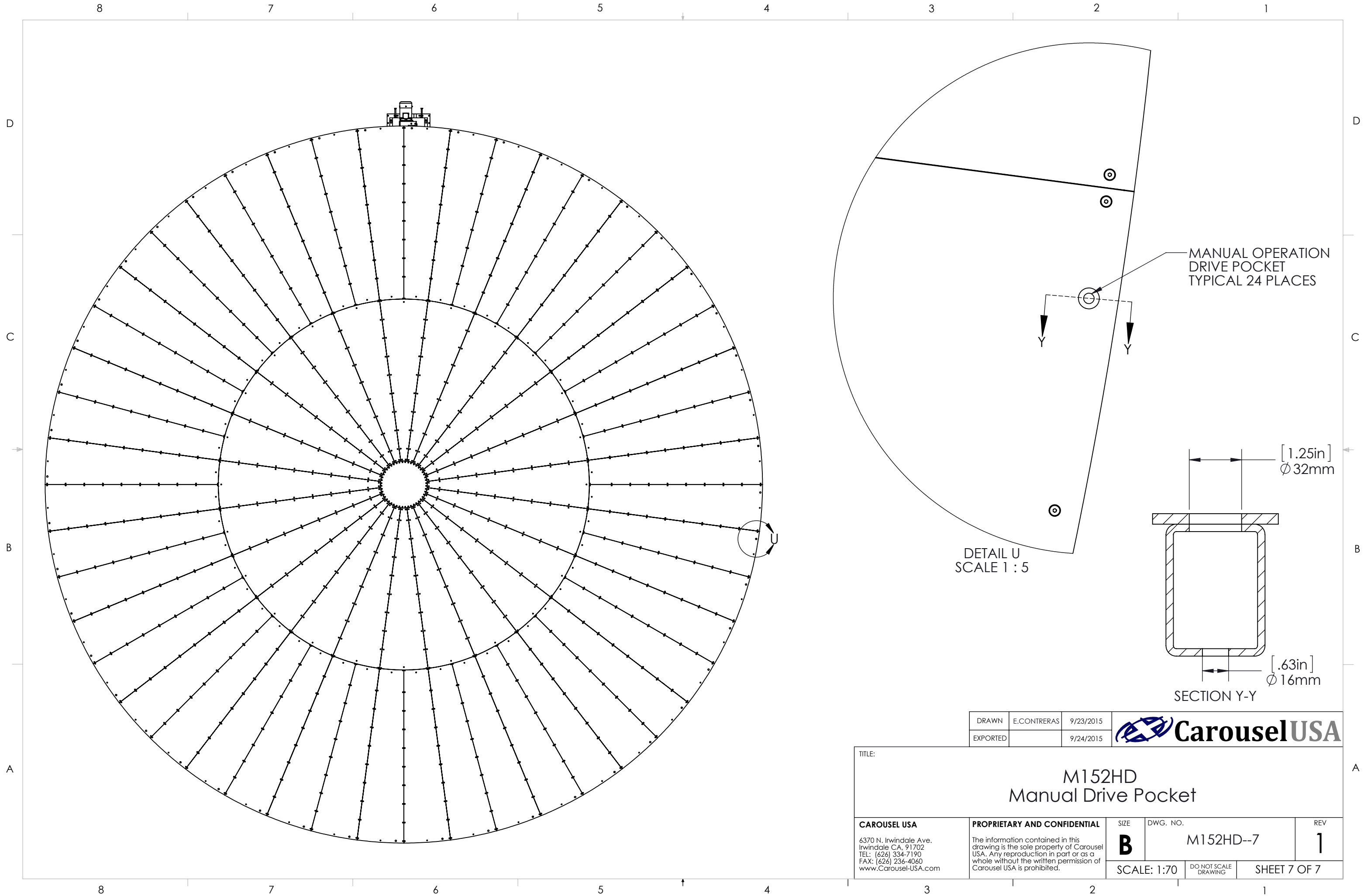

DRAWN	E.CONTRERAS	9/23/2015
EXPORTED		9/24/2015



TITLE:
M152HD
Manual Drive Pocket

CAROUSEL USA 6370 N. Irwindale Ave. Irwindale CA, 91702 TEL: (626) 334-7190 FAX: (626) 236-4060 www.Carousel-USA.com	PROPRIETARY AND CONFIDENTIAL The information contained in this drawing is the sole property of Carousel USA. Any reproduction in part or as a whole without the written permission of Carousel USA is prohibited.	SIZE	DWG. NO.	REV
		B	M152HD--7	1
SCALE: 1:70		DO NOT SCALE DRAWING	SHEET 7 OF 7	