

7th Edition



jay-cee sales & rivet inc.

"THE QUALITY RIVET PEOPLE"



www.rivetsinstock.com

32861 Chesley Drive, Farmington, MI 48336

Phone: (248) 478-2150 Fax: (248) 478-6416

email: sales@rivetsinstock.com

Our supplier is one of the world's market leaders in anaerobics, cyanoacrylates, epoxies and ultra-violet technologies. With low overhead and in-house chemical formulation and blending, we offer products with the same high quality and performance of name brands, but at cost savings of up to 40%.



Anaerobic Threadlockers - Lock and seal threaded fasteners.

Types: Low Strength, Medium Strength, Oil Tolerant, High Strength, Permanent Strength
 Sizes: 2 mL Bullet Tube, 10 mL Bottle, 50 mL Bottle, 250 mL Bottle, 1 L Jug



VC-3 Threadmate - Non-traditional threadlocker. Adjustable; Removable; Reusable.

Prevents loosening of fasteners from shock and vibration.
 Sizes: 1 mL Pillow Pack, 5 mL Tube, 30 mL Bottle w/ Brush Cap Applicator, 250 mL Can w/ Spout



Thread Sealants - Seal and secure metal pipes and fittings.

Types: Controlled Strength, High Strength, Pneumatic, Hydraulic, Refrigerant, General Purpose
 Sizes: 50 mL Tube, 250 mL Tube, 50 mL Bottle, 250 mL Bottle, 1 L Jug



Retaining Compounds - Increase shear strength on non-threaded, cylindrical metal assemblies.

Types: General Purpose, High Strength, Impact Resistant, Rapid Curing, Core Plug Sealant, High Temp.
 Sizes: 2 mL Bullet Tube, 10 mL Bottle, 50 mL Bottle, 250 mL Bottle, 1 L Jug

Liquid Gasketing - Form-in-place gasket for close-fitting, rigid, metal flanges.

Types: Flexible; High Temperature Rigid Flange
 Sizes: 50 mL Tube, 250 mL Tube, 300 mL Cartridge



Anti-Seize Compounds - Prevents seizing, galling, and cold welding.

Reduces excessive wear on threads, gears, cables, chains, and sprockets. Protects against corrosion.
 Types: Aluminum, Copper, and Graphite; Copper and Graphite; Nickel and Graphite
 Sizes: 2 mL Bullet Tube, 4 oz Jar w/ Brush Applicator, 8 oz Jar w/ Brush Applicator, 16 oz Jar w/ Brush



Cyanoacrylates (Super Glues) - Single-part, quick-fixturing, clear adhesives.

Types: Multi-Purpose, Wicking Grade, Metal Bonder, Plastic Bonder, Shock Resistant, Rubber Toughened
 Sizes: 2 mL Bullet Tube, 20 gm Tube, 20 gm Bottle, 1 oz Bottle, 1 lb Bottle

Light Cure Adhesives - Single-part acrylates that cure when exposed to UV light.

Types: Flexible; High Temperature Rigid Flange
 Sizes: 50 mL Tube, 250 mL Tube, 300 mL Cartridge



Structural Adhesives - Use with Activator to bond metal, composite, plastic, wood, & more.

Sizes: 50 mL Bottle, 1 L Bottle



Primers, Accelerators, and Activators - Use to promote maximum performance.

Hot-Melts / Urethanes / Epoxies - Solutions for a variety of assembly requirements.

Private Label Services - Create your own unique brand identity.

32861 Chesley Drive
 Farmington, Michigan 48336

PHONE: (248) 478-2150
 Fax: (248) 478-6416

Web address: www.rivetsinstock.com
 E-mail: Sales@rivetsinstock.com



CONTENTS

SOLID SMALL RIVETS UNDER 7/16 INCH DIAMETER	2-3	RIVET NUTS: L-SERIES	40-41
SOLID LARGE RIVETS 1/2 INCH DIAMETER AND OVER	4-5	RIVET NUTS: K-SERIES	42-43
RIVET BURRS	5	RIVET NUTS: HEX BODY	44
QUALITY STANDARDS & DATA	6-7	RIVET NUTS: FLAT HEAD	45
ALUMINUM RIVET HEAD STYLES	8-9	RIVET NUTS: THREADED INSERTS	45
ALUMINUM RIVET DATA	10	RIVET NUTS: COUNTERSUNK HEAD	46
TINNERS RIVETS	11	JACK NUTS	47
COPPER BELT RIVETS & BURRS	11	RIVNUT® PN - PLUSNUT® PRE-BULBED	48
SEMI-TUBULAR RIVETS	12-13	RIVNUT® PN - PLUSNUT®	49
BRAKE & CLUTCH RIVETS	14	THREAD REPAIR KITS - UNIQUE/SPECIAL SIZE	50
SECTION RIVETS	15	THREAD REPAIR KITS - INDIVIDUAL SIZE	51-52
BRASS ESCUTCHEON PINS	15	EYELETS	53
COPPER BRAKE BAND RIVETS	15	SPLIT RIVETS	54
DRIVE RIVETS: ALUMINUM	16-17	DRIVE SCREWS	54
DRIVE RIVETS: STEEL	18-19	COMPRESSION RIVETS/SPEEDY RIVETS	55
BLIND RIVETS: OPEN END	20-23	STEEL BARREL NUTS & SCREWS	56
BLIND RIVETS: CLOSED END	24-25	BINDER POST & SCREWS: BRASS	57
BLIND RIVETS: BULBTITE®	26-29	BINDER POST & SCREWS: ALUMINUM	58
BLIND RIVETS: Q® RIVET	30-32	BINDER POST & SCREWS: BLACK ANODIZED ALUMINUM	59
BLIND RIVETS: AVINOX II RIVETS	33	BINDER POST & SCREWS: PLASTIC	60
BLIND RIVETS: STRUCTURAL JC-LOCKS	34	CLEVIS PINS	61
BLIND RIVETS: 2-PIECE MATE RIVETS	35	HAIRPIN COTTERS & COTTER PINS	61
BLIND RIVETS: MULTIGRIP	36	CLECO FASTENERS/TEMPORARY RIVETS	62
BLIND RIVETS: DOME PEEL RIVETS	37	RIVET SETS - SQUEEZERS - TOOLS	63
BLIND RIVETS: TRIBEX	38	MS & AN SOLID RIVET HEAD STYLES/MARKINGS	64
LOCKBOLTS AND COLLARS	39		



SOLID SMALL RIVETS UNDER 7/16" INCH DIAMETER

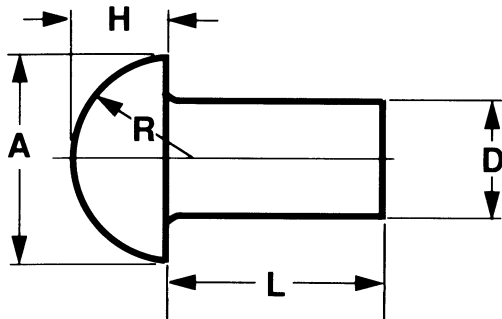

ROUND HEAD RIVETS

Nominal Size or Basic Shank Diameter	D		A		H		R	
	Shank Diameter		Head Diameter		Head Height		Head Radius	
	Max	Min	Max	Min	Max	Min	Approx	
1/16	0.062	0.064	0.059	0.122	0.102	0.052	0.042	0.055
3/32	0.094	0.096	0.090	0.182	0.162	0.077	0.065	0.084
1/8	0.125	0.127	0.121	0.235	0.215	0.100	0.088	0.111
5/32	0.156	0.158	0.152	0.290	0.268	0.124	0.110	0.138
3/16	0.188	0.191	0.182	0.348	0.322	0.147	0.133	0.166
7/32	0.219	0.222	0.213	0.405	0.379	0.172	0.158	0.195
1/4	0.250	0.253	0.244	0.460	0.430	0.196	0.180	0.221
9/32	0.281	0.285	0.273	0.518	0.484	0.220	0.202	0.249
5/16	0.312	0.316	0.304	0.572	0.538	0.243	0.225	0.276
11/32	0.344	0.348	0.336	0.630	0.592	0.267	0.247	0.304
3/8	0.375	0.380	0.365	0.684	0.646	0.291	0.271	0.332
13/32	0.406	0.411	0.396	0.743	0.699	0.316	0.294	0.358
7/16	0.438	0.443	0.428	0.798	0.754	0.339	0.317	0.387

Notes: 1. Approximate proportions: $A = 1.750 \times D$
 $H = 0.750 \times D$
 $R = 0.885 \times D$
 2. Length tolerance for rivets shall be plus or minus 0.016 in.

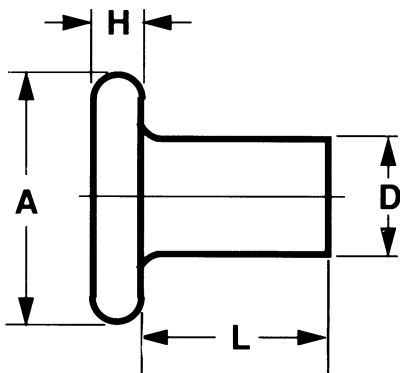

FLAT HEAD RIVETS

Nominal Size or Basic Shank Diameter	D		A		H		
	Shank Diameter		Head Diameter		Head Height		
	Max	Min	Max	Min	Max	Min	
1/16	0.062	0.064	0.059	0.140	0.120	0.027	0.017
3/32	0.094	0.096	0.090	0.200	0.180	0.038	0.026
1/8	0.125	0.127	0.121	0.260	0.240	0.048	0.036
5/32	0.156	0.158	0.152	0.323	0.301	0.059	0.045
3/16	0.188	0.191	0.182	0.387	0.361	0.069	0.055
7/32	0.219	0.222	0.213	0.453	0.427	0.080	0.065
1/4	0.250	0.253	0.244	0.515	0.485	0.091	0.075
9/32	0.281	0.285	0.273	0.579	0.545	0.103	0.085
5/16	0.312	0.316	0.304	0.641	0.607	0.113	0.095
11/32	0.344	0.348	0.336	0.705	0.667	0.124	0.104
3/8	0.375	0.380	0.365	0.769	0.731	0.135	0.115
13/32	0.406	0.411	0.396	0.834	0.790	0.146	0.124
7/16	0.438	0.443	0.428	0.896	0.852	0.157	0.135

Notes: 1. Approximate proportions: $A = 2.00 \times D$
 $H = 0.33 \times D$
 2. Length tolerance for rivets shall be plus or minus 0.016 in.

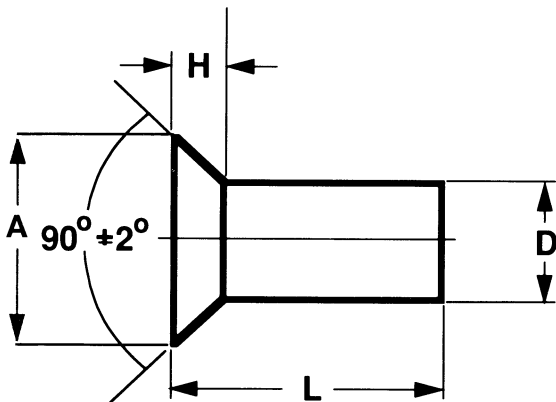

COUNTERSUNK HEAD RIVETS

Nominal Size or Basic Shank Diameter	D		A		H	
	Shank Diameter		Head Diameter		Head Height	
	Max	Min	Max	Min	Ref	
1/16	0.062	0.064	0.059	0.118	0.110	0.027
3/32	0.094	0.096	0.090	0.176	0.163	0.040
1/8	0.125	0.127	0.121	0.235	0.217	0.053
5/32	0.156	0.158	0.152	0.293	0.272	0.066
3/16	0.188	0.191	0.182	0.351	0.326	0.079
7/32	0.219	0.222	0.213	0.413	0.384	0.094
1/4	0.250	0.253	0.244	0.469	0.437	0.106
9/32	0.281	0.285	0.273	0.528	0.491	0.119
5/16	0.312	0.316	0.304	0.588	0.547	0.133
11/32	0.344	0.348	0.336	0.646	0.602	0.146
3/8	0.375	0.380	0.365	0.704	0.656	0.159
13/32	0.406	0.411	0.396	0.763	0.710	0.172
7/16	0.438	0.443	0.428	0.823	0.765	0.186
See Notes				1		2

Notes: 1. Calculated on basic diameter of rivet and 90 deg included angle extended to a sharp corner.
 2. Head height (H) is given for reference purposes only. Variations in this dimension are controlled by the diameters (A) and (D) and the included angle of the head.
 3. Approximate proportions: $A = 1.850 \times D$
 $H = 0.425 \times D$
 4. Length tolerance for rivets shall be plus or minus 0.016 in.



SOLID SMALL RIVETS UNDER 7/16" INCH DIAMETER

PAN HEAD RIVETS

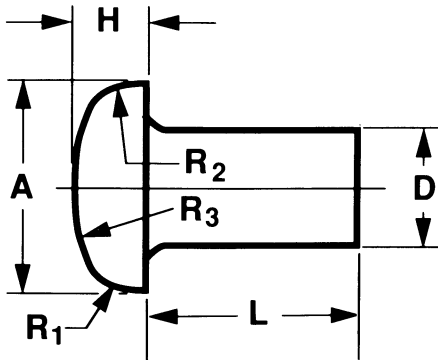

Nominal Size or Basic Shank Diameter	D		A		H		R ₁	R ₂	R ₃	
	Shank Diameter		Head Diameter		Head Height		Head Radius			
	Max	Min	Max	Min	Max	Min	Approx			
1/16	0.062	0.064	0.059	0.118	0.098	0.040	0.030	0.019	0.052	0.217
3/32	0.094	0.096	0.090	0.173	0.153	0.060	0.048	0.030	0.080	0.326
1/8	0.125	0.127	0.121	0.225	0.205	0.078	0.066	0.039	0.106	0.429
5/32	0.156	0.158	0.152	0.279	0.257	0.096	0.082	0.049	0.133	0.535
3/16	0.188	0.191	0.182	0.334	0.308	0.114	0.100	0.059	0.159	0.641
7/32	0.219	0.222	0.213	0.391	0.365	0.133	0.119	0.069	0.186	0.754
1/4	0.250	0.253	0.244	0.444	0.414	0.151	0.135	0.079	0.213	0.858
9/32	0.281	0.285	0.273	0.499	0.465	0.170	0.152	0.088	0.239	0.963
5/16	0.312	0.316	0.304	0.552	0.518	0.187	0.169	0.098	0.266	1.070
11/32	0.344	0.348	0.336	0.608	0.570	0.206	0.186	0.108	0.292	1.176
3/8	0.375	0.380	0.365	0.663	0.625	0.225	0.205	0.118	0.319	1.286
13/32	0.406	0.411	0.396	0.719	0.675	0.243	0.221	0.127	0.345	1.392
7/16	0.438	0.443	0.428	0.772	0.728	0.261	0.239	0.137	0.372	1.500

Notes: 1. Approximate proportions: $A = 1.750 \times D$
 $H = 0.570 \times D$
 $R_1 = 0.314 \times D$
 $R_2 = 0.850 \times D$
 $R_3 = 3.430 \times D$

2. Length tolerance for rivets shall be plus or minus 0.016 in.

TRUSS HEAD RIVETS

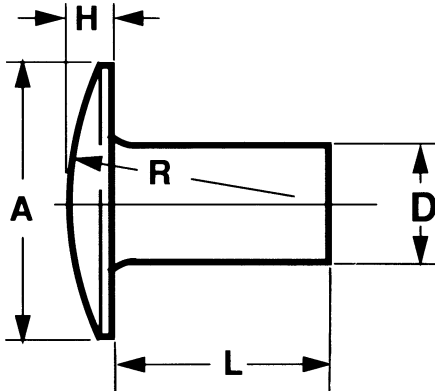

Nominal Size or Basic Shank Diameter	D		A		H		R	
	Shank Diameter		Head Diameter		Head Height		Head Radius	
	Max	Min	Max	Min	Max	Min	Approx	
3/32	0.094	0.096	0.090	0.226	0.206	0.038	0.026	0.239
1/8	0.125	0.127	0.121	0.297	0.277	0.048	0.036	0.314
5/32	0.156	0.158	0.152	0.368	0.348	0.059	0.045	0.392
3/16	0.188	0.191	0.182	0.442	0.422	0.069	0.055	0.470
7/32	0.219	0.222	0.213	0.515	0.495	0.080	0.066	0.555
1/4	0.250	0.253	0.244	0.590	0.560	0.091	0.075	0.628
9/32	0.281	0.285	0.273	0.661	0.631	0.103	0.085	0.706
5/16	0.312	0.316	0.304	0.732	0.702	0.113	0.095	0.784
11/32	0.344	0.348	0.336	0.806	0.776	0.124	0.104	0.862
3/8	0.375	0.380	0.365	0.878	0.848	0.135	0.115	0.942
13/32	0.406	0.411	0.396	0.949	0.919	0.145	0.123	1.028
7/16	0.438	0.443	0.428	1.020	0.990	0.157	0.135	1.098

Notes: 1. This rivet was previously designated as a wagon box rivet in addition to the present truss head designation.

2. Approximate proportions: $A = 2.300 \times D$
 $H = 0.330 \times D$
 $R = 2.512 \times D$

3. Length tolerance for rivets shall be plus or minus 0.016 in.

UNIVERSAL HEAD RIVETS

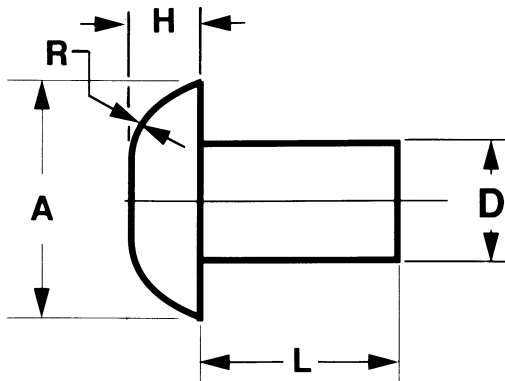

Nominal Size or Basic Shank Diameter	D		A		H		R	
	Shank Diameter		Head Diameter		Head Height		Head Radius	
	Max	Min	Max	Min	Max	Min	Approx	
1/16	.062	0.064	0.059	0.135	0.115	0.037	0.027	0.054
3/32	.093	0.096	0.090	0.197	0.177	0.051	0.039	0.082
1/8	.125	0.127	0.121	0.260	0.240	0.065	0.053	0.108
5/32	.156	0.158	0.152	0.323	0.301	0.079	0.065	0.135
3/16	.187	0.191	0.182	0.387	0.361	0.092	0.078	0.164
1/4	.250	0.253	0.244	0.515	0.485	0.120	0.104	0.217
5/16	.312	0.316	0.304	0.641	0.607	0.147	0.129	0.272
3/8	.375	0.380	0.365	0.769	0.731	0.176	0.156	0.328

Notes: 1. Approximate proportions: $A = 2.00 \times D$
 $H = 0.465 \times D$
 $R = 0.872 \times D$

2. Length tolerance for rivets shall be plus or minus 0.016 in.



SOLID LARGE RIVETS 1/2" AND OVER DIAMETER

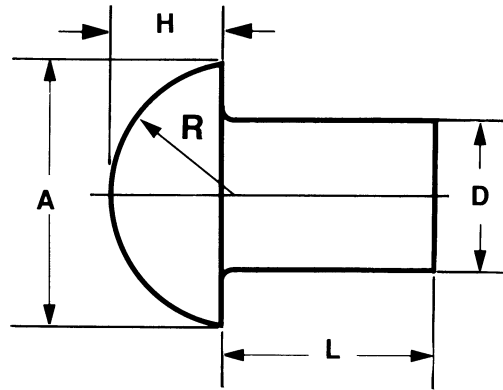

ROUND HEAD RIVETS

D Shank Diameter		A Head Diameter			H Head Height		R Head Radius	
Nominal Size	Max	Min	Basic	Max	Min	Max	Min (Basic)	Radius
1/2	0.500	0.520	0.478	0.875	0.938	0.844	0.406	0.443
5/8	0.625	0.655	0.600	1.094	1.157	1.063	0.500	0.553
3/4	0.750	0.780	0.725	1.312	1.390	1.281	0.593	0.664
7/8	0.875	0.905	0.850	1.531	1.609	1.500	0.687	0.775
1	1.000	1.030	0.975	1.750	1.828	1.719	0.781	0.885
1-1/8	1.125	1.160	1.098	1.969	2.063	1.938	0.891	0.996
1-1/4	1.250	1.285	1.223	2.188	2.282	2.157	0.985	1.107
1-3/8	1.375	1.415	1.345	2.406	2.500	2.375	1.078	1.217
1-1/2	1.500	1.540	1.470	2.625	2.719	2.594	1.188	1.328
1-5/8	1.625	1.665	1.588	2.844	2.938	2.813	1.282	1.439
1-3/4	1.750	1.790	1.713	3.062	3.171	3.031	1.375	1.549

Notes: 1. Approximate proportions of manufactured shape. $A = 1.75 \times D$; $H = 0.75 \times D$; $R = 0.885 \times D$.

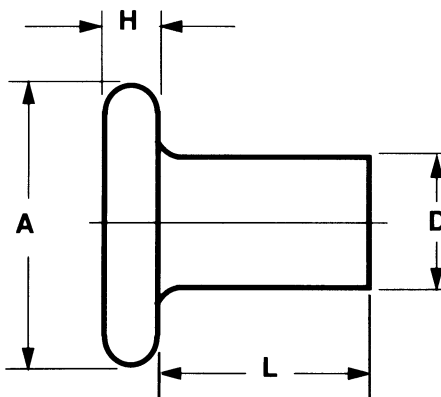

FLAT HEAD RIVETS

Nominal	Diameter of Body D		Diameter of Head A			Height of Head H		
	Max.	Min	Basic	Max	Min	Max	Min	
1/2	0.500	0.520	0.478	0.875	0.938	0.844	0.281	0.250
5/8	0.625	0.655	0.600	1.094	1.157	1.063	0.344	0.313
3/4	0.750	0.780	0.725	1.312	1.390	1.281	0.406	0.375
7/8	0.875	0.905	0.850	1.531	1.609	1.500	0.469	0.438
1	1.000	1.030	0.975	1.750	1.828	1.719	0.531	0.500
1-1/8	1.125	1.160	1.098	1.969	2.063	1.938	0.610	0.563
1-1/4	1.250	1.285	1.223	2.188	2.282	2.157	0.672	0.625
1-3/8	1.375	1.415	1.345	2.406	2.500	2.375	0.735	0.688

Notes: Approximate proportions: $A = 1.75 \times D$; $H = .500 \times D$; $D = \text{Basic diameter of rivet shank}$. Flat head rivets are **not standard**. Head dimensions can be modified or changed from those shown. The above dimensions are furnished when no other size is specified.



SOLID LARGE RIVETS 1/2" AND OVER DIAMETER

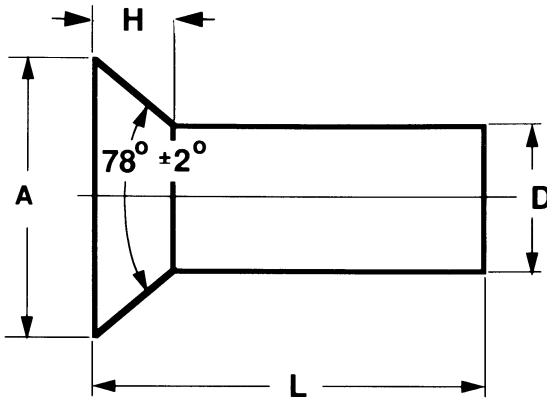

COUNTERSUNK HEAD RIVETS

Nominal Size of Basic Shank Diameter	D Shank Diameter		A Head Diameter		H Head Height	
	Max	Min	Max	Min	Ref	
	1/2	0.500	0.520	0.478	0.936	0.872
5/8	0.625	0.655	0.600	1.194	1.112	0.339
3/4	0.750	0.780	0.725	1.421	1.322	0.400
7/8	0.875	0.905	0.850	1.647	1.532	0.460
1	1.000	1.030	0.975	1.873	1.745	0.520
1-1/8	1.125	1.160	1.098	2.114	1.973	0.589
1-1/4	1.250	1.285	1.223	2.340	2.199	0.650
1-3/8	1.375	1.415	1.345	2.567	2.426	0.710
1-1/2	1.500	1.540	1.470	2.793	2.652	0.771
1-5/8	1.625	1.665	1.588	3.019	2.878	0.831
1-3/4	1.750	1.790	1.713	3.262	3.121	0.901
See Notes				2	3	4

- Notes:
1. Approximate proportions: $A = 1.81 \times D$; $H = 1.192 \left(\frac{\text{MAX } A-D}{2} \right)$
 2. Sharp edged calculated on basic diameter of rivet and 78-degree included angle extended to a sharp corner.
 3. Rounded or flat edged irregular shaped head since the heads of these rivets are not machined or trimmed, the circumference may be somewhat irregular and edges may be rounded or flat.
 4. Head height (H) is given for reference purposes only. Variations in this dimension are controlled by the diameters (A) and (D) and the included angle of the head.

LARGE RIVET LENGTH TOLERANCES

Lengths	Rivet Diameter (in.)	Length Tolerance (in.)	Lengths	Rivet Diameter (in.)	Length Tolerance (in.)
Up to and incl. 6 in.	1/2 and 5/8	± 1/32	Over 6 in.	1/2 and 5/8	± 1/16
	3/4 and 7/8	± 1/16		3/4 and 7/8	± 1/8
	1 and larger	± 3/32		1 and larger	± 3/16

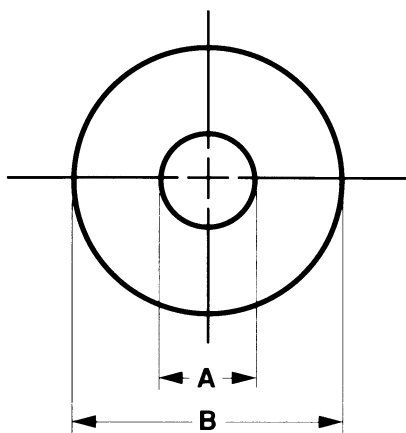

RIVET BURRS

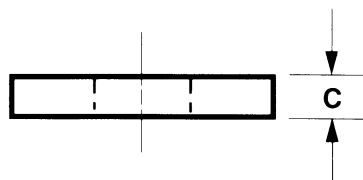

Recommended Burr Rivet Dia.	Inside Diameter A	Outside Diameter B	Thickness C	
			Min	Max
1/8	0.140	0.437	.036	.065
5/32	0.162	0.437	.036	.065
3/16	0.203	0.500	.036	.065
1/4	0.265	0.625	.036	.065

Burrs supplied in steel, aluminum and stainless steel.
Other sizes and materials quoted on request.



QUALITY STANDARDS

The different types of rivet imperfections indicated in these drawings are generally permissible by industry standards. Each imperfection is exaggerated for greater clarity. No more than three defects are permitted per rivet. A crack is defined as a clear, crystalline break passing through the grain or grain boundary. This classification includes nicks, seams, inclusions and gouges. Seams or longitudinal scratches sometimes cause cracks to appear.

Major Defects

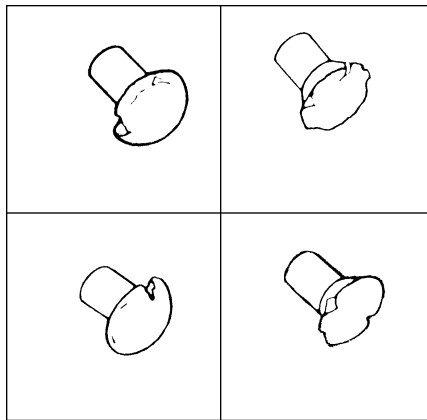

Minor Defects

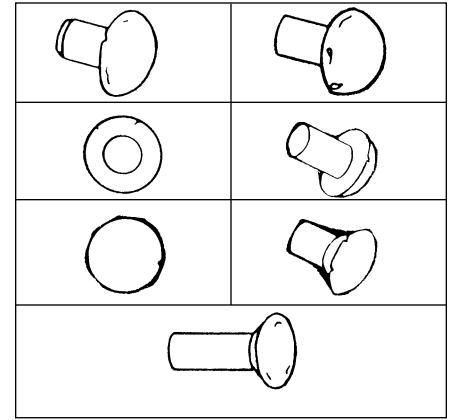

PRESSURES TO DRIVE RIVETS

Diameter	Tons Pressure Cold	Tons Pressure Hot
3/16"	4.5	
1/4"	7	
5/16"	12	
3/8"	16	
7/16"	22	
1/2"	29	13
5/8"	44	19
3/4"	64	28
7/8"	87	38
1"	112	50
1-1/8"		63
1-1/4"		77

Recommendation of Safe Practice to Form Steel Rivet Heads

Formula

$$\text{DIA}^2 \times 88.36 = \text{Tons of Pressure to Drive Rivets}$$

DRIVEN HEADS

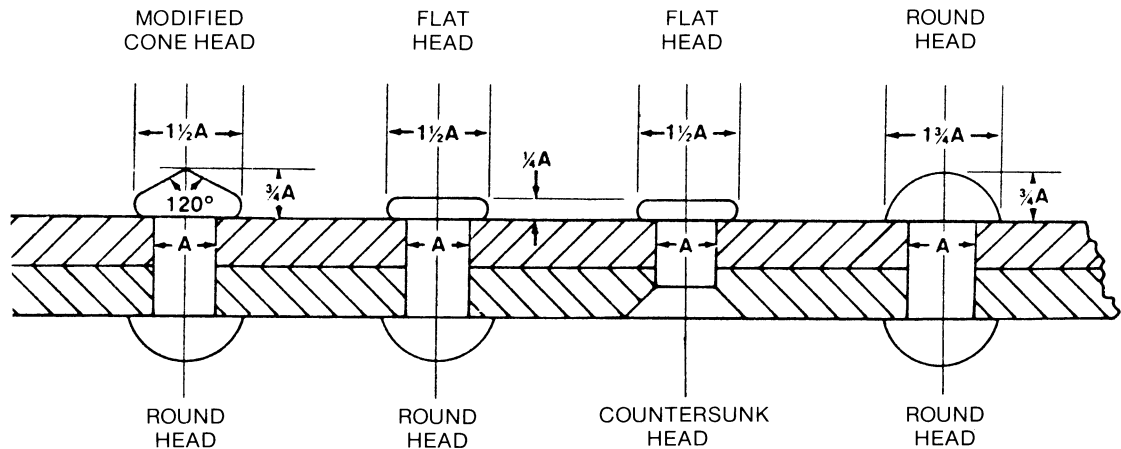

MANUFACTURED HEADS

The above driven heads represent what is considered good practice for riveting. Rivets used for cold riveting should be cold formed and must be annealed after forming before driving.

The pressure required to cold form the heads will, of course, depend on the material in the rivet. For the commonly used carbon steel rivet, the above listed pressures are needed.



RIVET LENGTHS FOR VARIOUS GRIPS

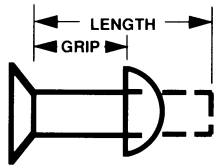
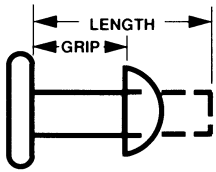
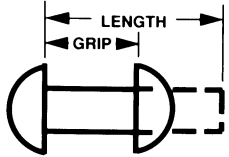

A general rule of thumb that is practiced throughout the industry in determining the length of small rivets is to take 1-1/2 times the body diameter and add it to the material thickness, result being the length.

Grips	Rivet Diameters								
	1/4	3/8	1/2	5/8	3/4	7/8	1	1-1/8	1-1/4
1/2	1-1/8	1-1/4	1-1/2	1-5/8	1-3/4	2	2-1/4	-	-
5/8	1-1/4	1-3/8	1-5/8	1-3/4	1-7/8	2-1/8	2-3/8	-	-
3/4	1-3/8	1-1/2	1-3/4	1-7/8	2-1/8	2-1/4	2-1/2	-	-
7/8	1-1/2	1-5/8	1-7/8	2	2-1/4	2-3/8	2-5/8	-	-
1	1-5/8	1-3/4	2	2-1/8	2-3/8	2-1/2	2-3/4	2-7/8	-
1/8	1-3/4	1-7/8	2-1/8	2-1/4	2-1/2	2-5/8	2-7/8	3	-
1/4	1-7/8	2	2-1/4	2-3/8	2-5/8	2-7/8	3	3-1/8	-
3/8	2	2-1/8	2-3/8	2-1/2	2-3/4	3	3-1/8	3-1/4	-
1/2	2-1/8	2-1/4	2-1/2	2-3/4	3	3-1/8	3-3/8	3-1/2	3-3/4
5/8	2-1/4	2-3/8	2-5/8	2-7/8	3-1/8	3-1/4	3-1/2	3-5/8	3-7/8
3/4	2-3/8	2-1/2	2-3/4	3	3-1/4	3-3/8	3-5/8	3-3/4	4
7/8	2-1/2	2-5/8	2-7/8	3-1/8	3-3/8	3-1/2	3-3/4	3-7/8	4-1/8
2	2-5/8	2-3/4	3-1/8	3-1/4	3-1/2	3-3/4	3-7/8	4	4-1/4
1/8	2-3/4	2-7/8	3-1/4	3-3/8	3-5/8	3-7/8	4	4-1/8	4-3/8
1/4	2-7/8	3	3-3/8	3-1/2	3-3/4	4	4-1/4	4-1/4	4-1/2
3/8	3	3-1/8	3-1/2	3-5/8	3-7/8	4-1/8	4-3/8	4-3/8	4-5/8
1/2	3-1/8	3-1/4	3-5/8	3-7/8	4	4-1/4	4-1/2	4-5/8	4-3/4
5/8	3-1/4	3-3/8	3-3/4	4	4-1/8	4-3/8	4-5/8	4-3/4	4-7/8
3/4	3-3/8	3-1/2	3-7/8	4-1/8	4-3/8	4-1/2	4-7/8	4-7/8	5-1/8
7/8	3-1/2	3-5/8	4	4-1/4	4-1/2	4-5/8	5	5	5-1/4
3	3-5/8	3-3/4	4-1/4	4-3/8	4-5/8	4-3/4	5-1/8	5-1/8	5-3/8
1/8	-	-	4-3/8	4-1/2	4-3/4	4-7/8	5-1/4	5-1/4	5-1/2
1/4	-	-	4-1/2	4-5/8	4-7/8	5	5-1/2	5-1/2	5-5/8
3/8	-	-	4-5/8	4-3/4	5	5-1/8	5-5/8	5-5/8	5-3/4
1/2	-	-	4-3/4	5	5-1/8	5-1/4	5-3/4	5-3/4	5-7/8
5/8	-	-	4-7/8	5-1/8	5-1/4	5-3/8	5-7/8	5-7/8	6
3/4	-	-	5	5-1/4	5-3/8	5-1/2	6-1/8	6-1/8	6-1/4
7/8	-	-	5-1/8	5-3/8	5-1/2	5-5/8	6-1/4	6-1/4	6-3/8
4	-	-	5-3/8	5-1/2	5-5/8	5-3/4	6-3/8	6-3/8	6-1/2
1/8	-	-	5-1/2	5-5/8	5-3/4	5-7/8	6-1/2	6-1/2	6-5/8
1/4	-	-	5-5/8	5-3/4	5-7/8	6-1/8	6-5/8	6-5/8	6-3/4
3/8	-	-	5-3/4	5-7/8	6	6-1/4	6-3/4	6-3/4	6-7/8
1/2	-	-	5-7/8	6	6-1/4	6-3/8	6-7/8	6-7/8	7
5/8	-	-	6	6-1/8	6-3/8	6-1/2	7	7	7-1/8
3/4	-	-	6-1/8	6-1/4	6-1/2	6-5/8	7-1/8	7-1/8	7-1/4
7/8	-	-	6-1/4	6-3/8	6-5/8	6-3/4	7-3/8	7-3/8	7-3/8
5	-	-	6-1/2	6-5/8	6-3/4	6-7/8	7-1/2	7-1/2	7-5/8
1/8	-	-	6-5/8	6-3/4	6-7/8	7	7-5/8	7-5/8	7-3/4
1/4	-	-	6-3/4	6-7/8	7	7-1/8	7-3/4	7-3/4	7-7/8
3/8	-	-	6-7/8	7	7-1/8	7-1/4	7-7/8	7-7/8	8
1/2	-	-	7	7-1/8	7-3/8	7-1/2	8-1/8	8-1/8	8-1/8
5/8	-	-	7-1/8	7-1/4	7-1/2	7-5/8	8-1/4	8-1/4	8-1/4
3/4	-	-	7-1/4	7-3/8	7-5/8	7-3/4	8-3/8	8-3/8	8-3/8
7/8	-	-	7-3/8	7-1/2	7-3/4	7-7/8	8-1/2	8-1/2	8-1/2
6	-	-	7-5/8	7-3/4	7-7/8	8	8-5/8	8-5/8	8-3/4
For Countersunk Deduct	1/4	1/4	3/8	1/2	5/8	3/4	7/8	7/8	1-1/16



HEAD STYLES OF ALUMINUM RIVETS

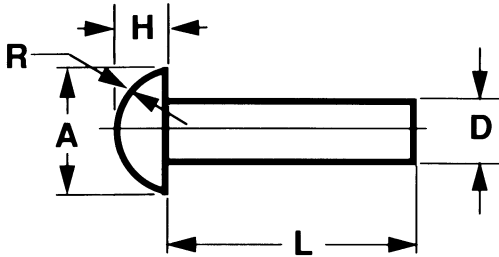

ROUND HEAD RIVETS

Nominal diameter (D)		A	H	R
Fraction	Decimal	Head Diameter	Head Height	Head Radius
3/32	0.094	0.187	0.070	0.098
1/8	0.125	0.250	0.094	0.130
5/32	0.156	0.312	0.117	0.163
3/16	0.187	0.375	0.141	0.195
1/4	0.250	0.500	0.188	0.260
5/16	0.312	0.625	0.234	0.326
3/8	0.375	0.750	0.281	0.391

Notes: 1. Approximate proportions: $A = 2.00 \times D$
 $H = 0.75 \times D$
 $R = 1.042 \times D$

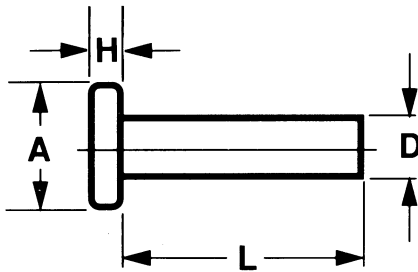

FLAT HEAD RIVETS

Nominal diameter (D)		A	H
Fraction	Decimal	Head Diameter	Head Height
3/32	0.094	0.187	0.038
1/8	0.125	0.250	0.050
5/32	0.156	0.312	0.062
3/16	0.187	0.375	0.075
1/4	0.250	0.500	0.100
5/16	0.312	0.625	0.125
3/8	0.375	0.750	0.150

Notes: 1. Approximate proportions: $A = 2.00 \times D$
 $H = 0.40 \times D$

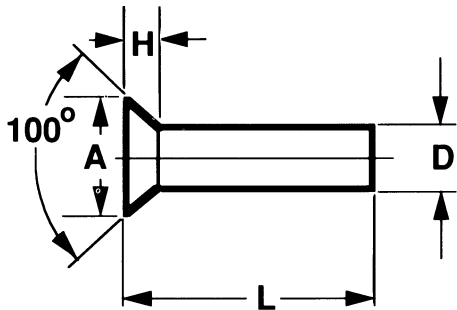

100° COUNTERSUNK HEAD RIVETS

Nominal diameter (D)		A	H
Fraction	Decimal	Head Diameter	Head Height
3/32	0.094	0.170	0.036
1/8	0.125	0.216	0.042
5/32	0.156	0.278	0.055
3/16	0.187	0.344	0.070
1/4	0.250	0.467	0.095
5/16	0.312	0.555	0.106
3/8	0.375	0.685	0.134

Notes: 1. Approximate proportions: $A = 1.54 \times D$
 $H = 0.26 \times D$

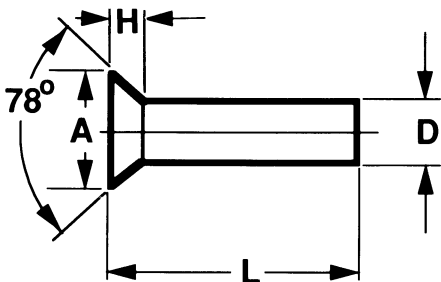

78° COUNTERSUNK HEAD RIVETS

Nominal diameter (D)		A	H
Fraction	Decimal	Head Diameter	Head Height
3/32	0.094	0.170	0.047
1/8	0.125	0.225	0.062
5/32	0.156	0.282	0.078
3/16	0.187	0.339	0.094
1/4	0.250	0.452	0.125
5/16	0.312	0.565	0.156
3/8	0.375	0.678	0.187

Notes: 1. Approximate proportions: $A = 1.81 \times D$
 $H = 0.50 \times D$



HEAD STYLES OF ALUMINUM RIVETS

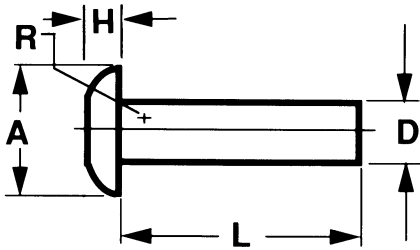

UNIVERSAL HEAD RIVETS

Nominal diameter (D)		A	H	R
Fraction	Decimal	Head Diameter	Head Height	Head Radius
3/32	0.094	0.187	0.045	0.082
1/8	0.125	0.250	0.059	0.108
5/32	0.156	0.312	0.072	0.135
3/16	0.187	0.375	0.085	0.164
1/4	0.250	0.500	0.112	0.217
5/16	0.312	0.625	0.138	0.272
3/8	0.375	0.750	0.166	0.328

Notes: 1. Approximate proportions: $A = 2.00 \times D$
 $H = 0.465 \times D$
 $R = 0.872 \times D$

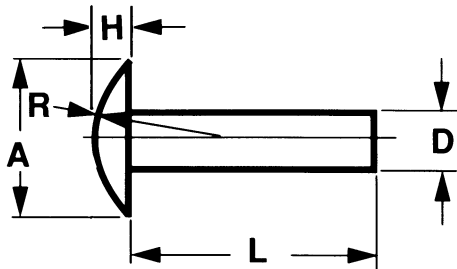

BRAZIER HEAD RIVETS

Nominal diameter (D)		A	H	R
Fraction	Decimal	Head Diameter	Head Height	Head Radius
3/32	0.094	0.234	0.047	0.170
1/8	0.125	0.312	0.062	0.227
5/32	0.156	0.391	0.078	0.283
3/16	0.187	0.469	0.094	0.340
1/4	0.250	0.625	0.125	0.453
5/16	0.312	0.781	0.156	0.566
3/8	0.375	0.937	0.187	0.680

Notes: 1. Approximate proportions: $A = 2.00 \times D$
 $H = 0.50 \times D$
 $R = 1.8125 \times D$

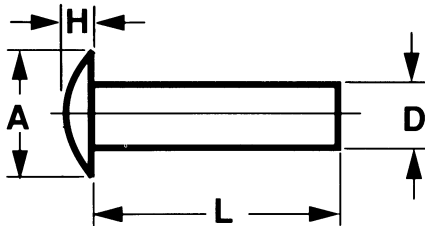

MODIFIED BRAZIER HEAD RIVETS

Nominal diameter (D)		A	H
Fraction	Decimal	Head Diameter	Head Height
3/32	0.094	0.156	0.031
1/8	0.125	0.235	0.047
5/32	0.156	0.312	0.063
3/16	0.187	0.390	0.078
1/4	0.250	0.468	0.094
5/16	0.312	0.625	0.125
3/8	0.375	0.781	0.156

Notes: 1. Approximate proportions: $A = 1.94 \times D$
 $H = 0.33 \times D$

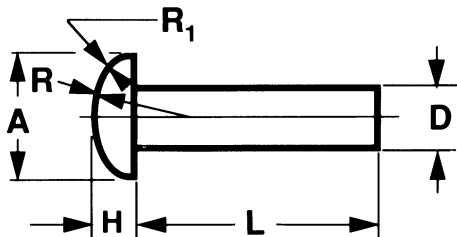

MUSHROOM HEAD RIVETS

Nominal diameter (D)		A	H	R	R ₁
Fraction	Decimal	Head	Diameter	Head	Height
3/32	0.094	0.187	0.059	0.153	0.047
1/8	0.125	0.250	0.078	0.204	0.062
5/32	0.156	0.312	0.098	0.255	0.078
3/16	0.187	0.375	0.117	0.306	0.094
1/4	0.250	0.500	0.156	0.408	0.125
5/16	0.312	0.625	0.195	0.511	0.156
3/8	0.375	0.750	0.234	0.613	0.187

Notes: 1. Approximate proportions: $A = 2.00 \times D$
 $H = 0.625 \times D$
 $R = 1.634 \times D$
 $R_1 = 0.50 \times D$



ALUMINUM RIVET DATA

APPROXIMATE PRESSURES REQUIRED TO DRIVE ROUND HEADS WITH SQUEEZE RIVETER

Pressures given are for complete round heads as dimensioned.

Rivet size, in.	Pressures in tons		
	Cold-driven		
	1100-F	2117-T4	6053-T61
3/16	3	6	4
1/4	6	10	8
3/8	14	23	16
1/2	25	39	30

1. Driven immediately after quenching.

RIVET TOLERANCES

Diameter of Shank

Dimensions in Inches

Nominal Diameter	Minus	Plus
0.052-0.094	0.001	0.003
0.095-0.156	0.001	0.004
0.157-0.219	0.002	0.005
0.220-0.375	0.003	0.006
0.376-0.625	0.004	0.008
0.626-0.875	0.006	0.012
0.876-1.000	0.007	0.015

Height of Head

Plus 8 percent minus 4 percent of the nominal or basic head height, but in no case less than ± 0.005 in.

Out-of-Roundness of Head and Eccentricity of Head in Relation to Shank

Dimensions in Inches

Nominal head diameter	Total dial indicator reading resulting from eccentricity and out-of-roundness not to exceed
up to 1/4	0.015
over 1/4 to 3/8	0.020

Length of Shank

Diameters to 3/4 in. x up to 4 in. long inclusive $\pm 1/64$ in. Diameters to 3/4 in. in lengths over 4 in. $\pm 1/32$ in. Diameters over 3/4 in. to 4 in. long $\pm 1/32$ in. Diameters over 3/4 in. in lengths over 4 in. $\pm 1/16$ in.

Diameter of Head

Because the heads of these rivets are not machined or trimmed, the circumference may be irregular and the edges rounded or flat.

The diameter of the rivet head shall be within -8 percent and + 4 percent of the nominal head diameter



TINNERS RIVETS & COPPER BELT RIVETS AND BURRS

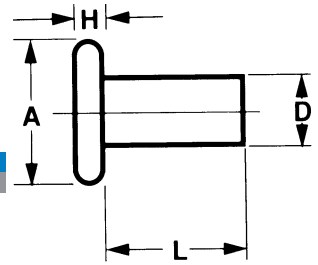

FLAT HEAD TINNERS RIVETS

Diameter of Body D			Diameter of Head A		Height of Head H		Length		
Size No.	Max.	Min.	Max.	Min.	Max.	Min.	Nom.	Max.	Min.
6 oz.	0.081	0.075	0.213	0.193	0.028	0.016	1/8	0.135	0.115
8 oz.	0.091	0.085	0.225	0.205	0.036	0.024	5/32	0.166	0.146
10 oz.	0.097	0.091	0.250	0.230	0.037	0.025	11/64	0.182	0.162
12 oz.	0.107	0.101	0.265	0.245	0.037	0.025	3/16	0.198	0.178
14 oz.	0.111	0.105	0.275	0.255	0.038	0.026	3/16	0.198	0.178
1 lb.	0.113	0.107	0.285	0.265	0.040	0.028	13/64	0.213	0.193
1-1/4 lb.	0.122	0.116	0.295	0.275	0.045	0.033	7/32	0.229	0.209
1-1/2 lb.	0.132	0.126	0.316	0.294	0.046	0.034	15/64	0.244	0.224
1-3/4 lb.	0.136	0.130	0.331	0.309	0.049	0.035	1/4	0.260	0.240
2 lb.	0.146	0.140	0.341	0.319	0.050	0.036	17/64	0.276	0.256
2-1/2 lb.	0.150	0.144	0.311	0.289	0.069	0.055	9/32	0.291	0.271
3 lb.	0.163	0.154	0.329	0.303	0.073	0.059	5/16	0.323	0.303
3-1/2 lb.	0.168	0.159	0.348	0.322	0.074	0.060	21/64	0.338	0.318
4 lb.	0.179	0.170	0.368	0.342	0.076	0.062	11/32	0.354	0.334
5 lb.	0.190	0.181	0.388	0.362	0.084	0.070	3/8	0.385	0.365
6 lb.	0.206	0.197	0.419	0.393	0.090	0.076	25/64	0.401	0.381
7 lb.	0.223	0.214	0.431	0.405	0.094	0.080	13/32	0.416	0.396
8 lb.	0.227	0.218	0.475	0.445	0.101	0.085	7/16	0.448	0.428
9 lb.	0.241	0.232	0.490	0.460	0.103	0.087	29/64	0.463	0.443
10 lb.	0.241	0.232	0.505	0.475	0.104	0.088	15/32	0.479	0.459
12 lb.	0.263	0.251	0.532	0.498	0.108	0.090	1/2	0.510	0.490
14 lb.	0.288	0.276	0.577	0.543	0.113	0.095	33/64	0.525	0.505
16 lb.	0.304	0.292	0.597	0.563	0.128	0.110	17/32	0.541	0.521
18 lb.	0.347	0.335	0.706	0.668	0.156	0.136	19/32	0.603	0.583

COPPER BELT RIVETS AND BURRS

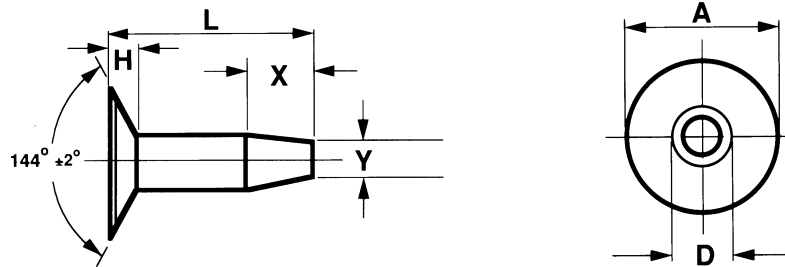

Diameter of Body D			Diameter of Head A		Height of Head H		Point	
Size No.	Max.	Min.	Max.	Min.	Max.	Min.	Dia. Y	Length X
							Nom.	Nom.
15	0.091	0.087	0.255	0.245	0.030	0.020	0.070	0.114
14	0.103	0.099	0.322	0.302	0.035	0.025	0.077	0.143
13	0.119	0.115	0.353	0.333	0.045	0.035	0.090	0.160
12	0.138	0.134	0.385	0.365	0.050	0.040	0.108	0.166
11	0.142	0.138	0.416	0.396	0.055	0.045	0.112	0.166
10	0.152	0.148	0.447	0.427	0.060	0.050	0.122	0.166
9	0.162	0.158	0.478	0.458	0.063	0.053	0.130	0.177
8	0.182	0.178	0.510	0.490	0.068	0.058	0.150	0.177
7	0.192	0.188	0.577	0.547	0.075	0.065	0.160	0.177
6	0.229	0.225	0.702	0.672	0.095	0.085	0.190	0.217
5	0.251	0.246	0.890	0.860	0.115	0.095	0.207	0.246
4	0.271	0.266	0.952	0.922	0.120	0.100	0.240	0.171

All dimensions are given in inches. Length tolerance on rivets shall be plus 1/32 inch and minus 0 inch.

COPPER BURR DIMENSIONS

	SIZE OR NO.	3	4	5	6	7	8	9	10	11	12	13	14	15	16
	O.D., INCHES (B)		.922	.875	.813	.656	.500	.469	.438	.406	.391	.360	.344	.313	.281
I.D. INCHES (A)		.290	.256	.223	.206	.176	.166	.146	.138	.128	.124	.106	.093	.086	.067
THICKNESS, INCHES (C)		.081	.071	.064	.057	.051	.045	.040	.036	.031	.028	.025	.022	.020	.018
APPROX. NO. PER LB.		64	76	102	184	380	465	580	750	950	1240	1350	2050	2950	3825



SEMI-TUBULAR RIVETS

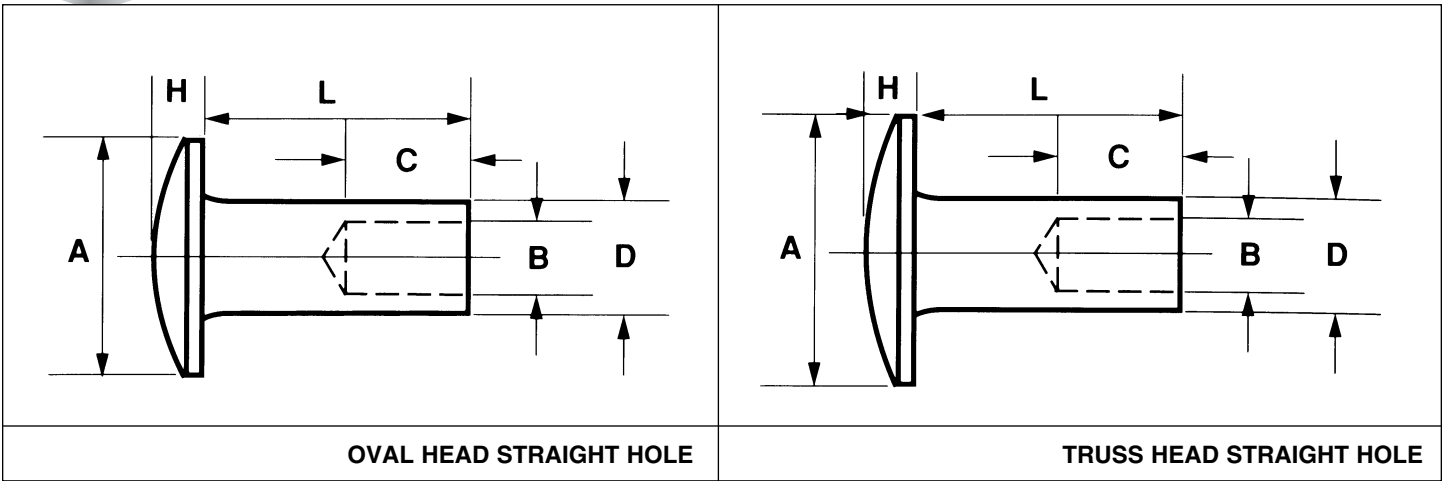

“L” DIMENSION DETERMINED BY APPLICATION

Nominal Shank Diameter	Shank Diameter D		Head Style	Head Diameter A		Head Thickness H		Hole Diameter B		Hole Depth C	Suggested Clinch Allowance	Hole Dia. in Assembly
	Min.	Max.		Basic	Tol.	Basic	Tol.	Min.	Max.			
1/16	.058	.061	Oval	.109	± .005	.017	± .002	.039	.044	0.046	0.040	0.067
1/16	.058	.061	Truss	.125	± .005	.017	± .002	.039	.044	0.046	0.040	0.067
3/32	.085	.089	Oval	.147	± .005	.023	± .003	.062	.068	0.064	0.045	0.093
3/32	.085	.089	Truss	.187	± .005	.023	± .003	.062	.068	0.064	0.045	0.093
3/32	.095	.099	Oval	.156	± .005	.023	± .003	.070	.076	0.077	0.050	0.100
3/32	.095	.099	Truss	.187	± .005	.029	± .003	.070	.076	0.077	0.050	0.100
1/8	.118	.123	Oval	.218	± .005	.034	± .004	.084	.090	0.094	0.075	0.128
1/8	.118	.123	Truss	.281	± .005	.034	± .004	.084	.090	0.094	0.075	0.128
9/64	.141	.146	Oval	.234	± .005	.040	± .005	.100	.107	0.126	0.092	0.152
9/64	.141	.146	Truss	.312	± .006	.040	± .005	.100	.107	0.126	0.092	0.152
5/32	.151	.156	Oval	.312	± .006	.046	± .005	.110	.117	0.155	0.096	0.165
5/32	.151	.156	Truss	.328	± .006	.046	± .005	.110	.117	0.155	0.096	0.165
3/16	.182	.188	Oval	.312	± .006	.060	± .005	.134	.141	0.155	0.120	0.196
3/16	.182	.188	Truss	.375	± .006	.060	± .005	.134	.141	0.155	0.120	0.196
7/32	.213	.220	Oval	.375	± .006	.063	± .005	.158	.165	0.187	0.137	0.228
7/32	.213	.220	Truss	.437	± .006	.080	± .005	.158	.165	0.187	0.137	0.228
1/4	.244	.252	Oval	.437	± .007	.068	± .007	.176	.184	0.219	0.157	0.265
1/4	.244	.252	Truss	.500	± .007	.078	± .007	.176	.184	0.219	0.157	0.265
9/32	.281	.289	Oval	.437	± .007	.068	± .007	.187	.195	0.219	0.172	0.297
9/32	.281	.289	Truss	.500	± .007	.078	± .007	.187	.195	0.219	0.172	0.297
5/16	.302	.310	Oval	.500	± .008	.093	± .007	.211	.219	0.243	0.188	0.328
5/16	.302	.310	Truss	.562	± .008	.093	± .007	.211	.219	0.243	0.188	0.328
3/8	.370	.380	Oval	.500	± .008	.125	± .007	.276	.286	0.281	0.219	0.390
3/8	.370	.380	Truss	.750	± .010	.156	± .007	.276	.286	0.281	0.219	0.390
7/16	.437	.442	Oval								0.250	0.443
7/16	.437	.442	Truss								0.250	0.443
1/2	.478	.520	Oval								0.281	0.516
1/2	.478	.520	Truss								0.281	0.516

AS REQUIRED



SEMI-TUBULAR RIVET DATA

The LENGTH (L) of rivet to be used is determined by adding the MATERIAL THICKNESS (MT) and the CLINCH ALLOWANCE (CA). Specify the length to the nearest fraction (not less than 64ths).

EXAMPLE: to determine the length of a 1/8 diameter for two parts each of which are .093" thick.

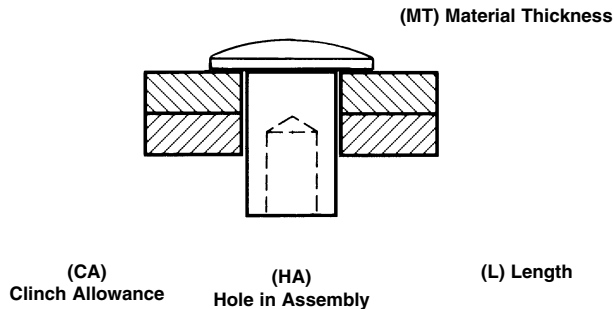

Total work thickness (2 x .093") 186
 Clinch allowance for 1/8" diameter..... 075
 Total 261
 Rivet length (nearest fraction = .265) 17/64"

GENERAL DATA:

Bearing surface for the oval and truss head rivets shall be at right angles with the body within 2 degrees.

Eccentricity of the rivet head to the shank, unevenness of the tubular end, surface seams or other imperfections shall not be such that the usability of the rivet will be impaired.

Radius of the fillet under the head of oval and truss head rivets shall not exceed the values in standards shown in table 2.

Materials of semi-tubular rivets shall be low carbon steel (0.1 of 1 percent carbon or less), commercial yellow brass, copper, aluminum and other materials as agreed upon between purchaser and supplier.

NOTES:

1. All dimensions are in inches.
2. Rivet length is measured from the under side of rivet head.
3. The hole depth to point of apex shall not be greater than shank length.
4. Because the heads of these rivets are not machined or trimmed the circumference may be somewhat irregular and edges may be rounded or flat.

TABLE 2 / LENGTH INCREMENTS, LENGTH TOLERANCES AND FILLET RADIUS STANDARDS

Body Diameter Limits	Length Increment	Minimum Length	Length Tolerances			Maximum Fillet Radius
			Up To And Including 4 Times Body Diameter	Over 4 Times Body Diameter And Up To And Including 8 Times Body Diameter	Over 8 Times Body Diameter	
.118 - .123	1/64"	1/8"	± .007	± .010	± .015	.020
.140 - .146	1/32"	1/8"	± .010	± .012	± .015	.025
.149 - .156	1/32"	5/32"	± .010	± .012	± .015	.025
.181 - .188	1/32"	3/16"	± .010	± .012	± .015	.035
.213 - .220	1/16"	3/16"	± .010	± .015	± .020	.030
.243 - .250	1/16"	7/32"	± .010	± .015	± .020	.030
.273 - .281	1/16"	1/4"	± .010	± .015	± .020	.030
.303 - .312	1/16"	1/4"	± .010	± .015	± .020	.030
.375 - .500	1/16"	3/8"	± .010	± .015	± .020	.030

FORMULA NEEDED FOR UPSETTING, STEEL SEMI-TUBULAR RIVETS

$$\left[\left((\text{DIA.}^2 \times \pi) \div 4 \right) - \left(\left(\frac{\text{ID. of SHANK}^2}{4} \right) \times \pi \right) \right] \times 250,000$$



STANDARD BRAKE AND CLUTCH RIVETS

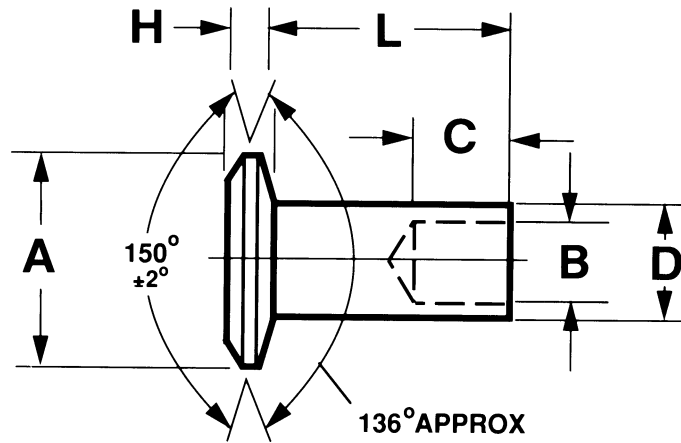

BRAKE LINING RIVETS

Nominal Shank Diameter	Nominal Head Diameter	Brake Rivet Number	D		A		H		B		C Hole Depth to Start of Apex.
			Shank Diameter		Head Diameter		Head Thickness		Hole Diameter		
			Min.	Max.	Min.	Max.	Min.	Max.	Min.	Max.	
9/64	19/64	BR 4-	0.141	0.146	0.289	0.303	0.035	0.045	.099	.105	0.141
9/64	23/64	BR 5-	0.141	0.146	0.351	0.367	0.041	0.051	.099	.105	0.141
3/16	23/64	BR 7-	0.182	0.188	0.351	0.367	0.041	0.051	.133	.139	0.188
3/16	15/32	BR 8-	0.182	0.188	0.458	0.478	0.053	0.067	.133	.139	0.188
.195/200	1/2	BR 20-	0.195	0.200	0.493	0.507	0.053	0.067	.135	.141	0.188
1/4	15/32	BR 10-	0.244	0.252	0.458	0.478	0.053	0.067	.173	.183	0.250

CLUTCH FACING RIVETS

Nominal Shank Diameter	Nominal Head Diameter	Brake Rivet Number	D		A		H		B		C Hole Depth to Start of Apex.
			Shank Diameter		Head Diameter		Head Thickness		Hole Diameter		
			Min.	Max.	Min.	Max.	Min.	Max.	Min.	Max.	
9/64	19/64	BR 3-	.141	.146	.289	.303	.035	.045	.099	.105	0.218
9/64	23/64	BR 5-	.141	.146	.351	.367	.041	.051	.099	.105	0.141
9/64	23/64	BR 16-	.141	.146	.351	.367	.041	.051	.099	.105	0.218
5/32	23/64	BR 11-	.151	.156	.351	.367	.041	.051	.107	.114	0.250
3/16	23/64	BR 17-	.182	.188	.351	.367	.041	.051	.133	.139	0.281

BRAKE LINING RIVETS

Nominal Shank Diameter	Nominal Head Diameter	Brake Rivet Number	D		A		H		B		C Hole Depth to Start of Apex.
			Shank Diameter		Head Diameter		Head Thickness		Hole Diameter		
			Min.	Max.	Min.	Max.	Min.	Max.	Min.	Max.	
9/64	19/64	BR 22-	.141	.146	.287	.307	.036	.044	.099	.105	0.140
3/16	23/64	BR 24-	.182	.188	.349	.369	.036	.044	.133	.139	0.187
.210	23/64	BR 23-	.208	.212	.349	.369	.036	.044	.165	.169	0.187

Above rivets available in brass and steel. After selecting the style and dimensions of the rivet required, a suffix must be added to the part number indicating the length of rivet in 16ths of an inch. Example: A brake-rivet 5/16th of an inch long would be BR4-5B, if the same part was steel the part number would be BR4-5S.



SECTION RIVETS • BRASS ESCUTCHEON PINS COPPER BRAKE BAND RIVETS

OVAL HEAD

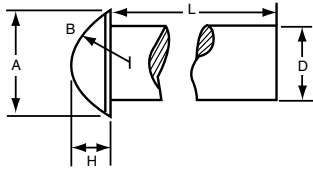

LOW CARBON STEEL
PLAIN FINISH • ANNEALED

COUNTERSUNK HEAD

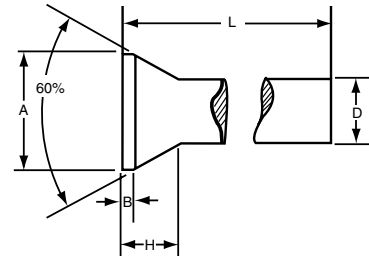

		5	5-1/2	6
D	D DIAMETER, MAX	.220	.212	.203
	SHANK DIAMETER, MIN.	.215	.205	.198
A	HEAD DIAMETER, MAX.	.385	.327	.327
	HEAD DIAMETER, MIN.	.365	.307	.307
H	HEAD HEIGHT, MAX.	.169	.125	.125
	HEAD HEIGHT, MIN.	.154	.115	.115
B	HEAD RADIUS	.169R	.169R	.169R
		.178R	.178R	.179R

		5-1/2	6
D	SHANK DIAMETER, MAX	.212	.203
	SHANK DIAMETER, MIN.	.205	.198
A	HEAD DIAMETER, MAX.	.306	.306
	HEAD DIAMETER, MIN.	.286	.286
H	HEAD HEIGHT, MAX.	.091	.099
	HEAD HEIGHT, MIN.	.076	.084
B	FEED THICKNESS, MAX.	.008	.008
	FEED THICKNESS, MIN.	.000	.000

BRASS ESCUTCHEON PINS • OVAL HEAD

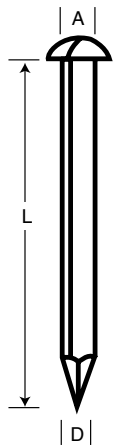

Gauge	D Shank Diameter	A Head Diameter
12	.109	.218
13	.095	.190
14	.083	.166
15	.072	.144
16	.065	.130
17	.058	.116
18	.049	.098

- Notes: 1.) All Head Diameters and Head Thickness Dimensions are $\pm .005$
 2.) Length Tolerances are –
 1/4 to 5/8 $\pm .015$ 3/4 to 7/8 $\pm .020$
 1" to 1-1/4 $\pm .025$
 1-1/2 to 2" $\pm .030$
 3.) 12 to 16 Gauge available to 2" Long
 17 to 18 Gauge available to 1-3/4" Long

COPPER BRAKE BAND RIVETS - COUNTERSUNK HEAD

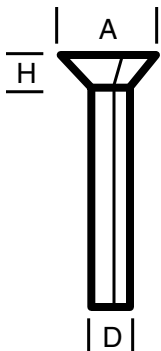

Size or No.	A Diameter of Head	H Thickness of Head	D Diameter of Shank
4	.406	.125	.238
5	.382	.125	.220
6	.359	.125	.203
7	.343	.109	.180
8	.328	.250	.165
9	.290	.062	.148
10	.250	.062	.134
12	.225	.046	.109



ALUMINUM DRIVE RIVETS

Ø 3.2 (.125)

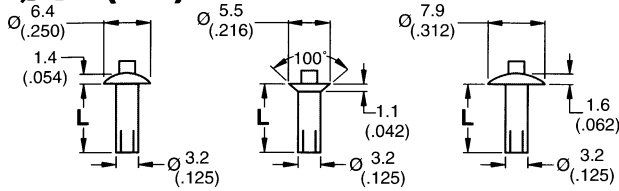

Ø 4 (.156)

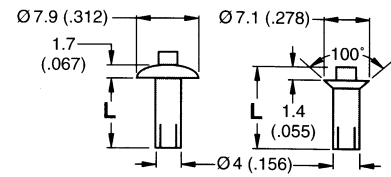

PART NUMBERS			L	GRIP			L	PART NUMBERS	
Universal Head	100° CSK Head	Full Brazier Head		MIN.	NOM.	MAX.		Universal Head	100° CSK Head
38-104-01-13			4 (.156)	0.4 (.016)	0.8 (.031)	1.2 (.047)	4.8 (.188)	38-105-01-13	
38-104-02-13			4 (.156)	1.2 (.047)	1.6 (.063)	2 (.078)	4.8 (.188)	38-105-02-13	
38-104-03-13	38-504-03-13	38-204-03-13	4.8 (.188)	2 (.078)	2.4 (.094)	2.8 (.109)	5.6 (.219)	38-105-03-13	
38-104-04-13	38-504-04-13	38-204-04-13	5.6 (.219)	2.8 (.109)	3.2 (.125)	3.6 (.141)	6.4 (.250)	38-105-04-13	38-505-04-13
38-104-05-13	38-504-05-13	38-204-05-13	6.4 (.250)	3.6 (.141)	4 (.156)	4.4 (.172)	7.1 (.281)	38-105-05-13	38-505-05-13
38-104-06-13	38-504-06-13	38-204-06-13	7.1 (.281)	4.4 (.172)	4.8 (.188)	5.2 (.203)	7.9 (.313)	38-105-06-13	38-505-06-13
38-104-07-13	38-504-07-13	38-204-07-13	7.9 (.313)	5.2 (.203)	5.6 (.219)	6 (.234)	8.7 (.344)	38-105-07-13	38-505-07-13
38-104-08-13	38-504-08-13	38-204-08-13	8.7 (.344)	6 (.234)	6.4 (.250)	6.8 (.266)	9.5 (.375)	38-105-08-13	38-505-08-13
38-104-09-13	38-504-09-13	38-104-09-13	9.5 (.375)	6.8 (.266)	7.1 (.281)	7.5 (.297)	10.3 (.406)	38-105-09-13	38-505-09-13
38-104-10-13	38-504-10-13		10.3 (.406)	7.5 (.297)	7.9 (.313)	8.3 (.328)	11.1 (.438)	38-105-10-13	38-505-10-13
38-104-11-13	38-504-11-13		11.1 (.438)	8.3 (.328)	8.7 (.344)	9.1 (.359)	11.9 (.469)	38-105-11-13	38-505-11-13
38-104-12-13	38-504-12-13	38-204-12-13	11.9 (.469)	9.1 (.359)	9.5 (.375)	9.9 (.391)	12.7 (.500)	38-105-12-13	38-505-12-13
38-104-13-13	38-504-13-13		12.7 (.500)	9.9 (.391)	10.3 (.406)	10.7 (.422)	13.5 (.531)	38-105-13-13	38-505-13-13
38-104-14-13			13.5 (.531)	10.7 (.422)	11.1 (.438)	11.5 (.453)	14.3 (.563)	38-105-14-13	38-505-14-13
				11.5 (.453)	11.9 (.469)	12.3 (.484)	15.1 (.594)	38-105-15-13	38-505-15-13
				12.3 (.484)	12.7 (.500)	13.1 (.516)	15.9 (.625)	38-105-16-13	38-505-16-13
				13.1 (.516)	13.5 (.531)	13.9 (.547)	16.7 (.656)	38-105-17-13	38-505-17-13
				13.9 (.547)	14.3 (.563)	14.7 (.578)	17.5 (.688)	38-105-18-13	38-505-18-13
				14.7 (.578)	15.1 (.594)	15.5 (.609)	18.3 (.719)	38-105-19-13	38-505-19-13
				15.5 (.609)	15.9 (.625)	16.3 (.641)	19.1 (.750)	38-105-20-13	38-505-20-13

Ø 4.8 (.188)

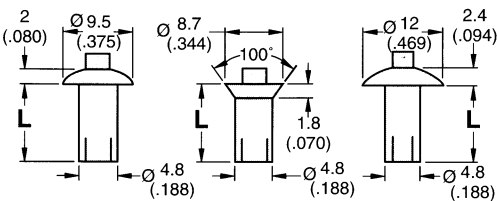

Ø 6.4 (.250)

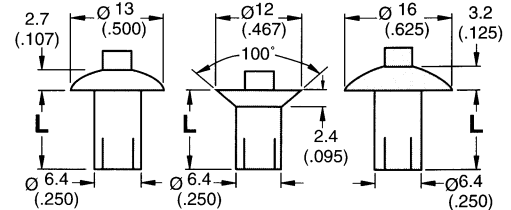

PART NUMBERS			L	GRIP			L	PART NUMBERS		
Universal Head	100° CSK Head	Full Brazier Head		MIN.	NOM.	MAX.		Universal Head	100° CSK Head	Full Brazier Head
38-106-02-16		38-206-02-16	6.4 (.250)	1.2 (.047)	2.4 (.094)	3.6 (.141)	6.4 (.250)	38-108-02-16		38-208-02-16
38-106-04-16		38-206-04-16	7.1 (.281)	2 (.078)	3.2 (.125)	4.4 (.172)	7.1 (.281)	38-108-04-16		38-208-04-16
38-106-06-16	38-506-06-16	38-206-06-16	8.7 (.344)	3.6 (.141)	4.8 (.188)	6 (.234)	8.7 (.344)	38-108-06-16	38-508-06-16	38-208-06-16
38-106-08-16	38-506-08-16	38-206-08-16	10.3 (.406)	5.2 (.203)	6.4 (.250)	7.5 (.297)	10.3 (.406)	38-108-08-16	38-508-08-16	38-208-08-16
38-106-10-16	38-506-10-16	38-206-10-16	11.9 (.469)	6.8 (.266)	7.9 (.313)	9.1 (.359)	11.9 (.469)	38-108-10-16	38-508-10-16	38-208-10-16
38-106-12-16	38-506-12-16	38-206-12-16	13.5 (.531)	8.3 (.328)	9.5 (.375)	10.7 (.422)	13.5 (.531)	38-108-12-16	38-508-12-16	38-208-12-16
38-106-14-16	38-506-14-16	38-206-14-16	15.1 (.594)	9.9 (.391)	11.1 (.438)	12.3 (.484)	15.1 (.594)	38-108-14-16	38-508-14-16	38-208-14-16
38-106-16-16	38-506-16-16	38-206-16-16	16.7 (.656)	11.5 (.453)	12.7 (.500)	13.9 (.547)	16.7 (.656)	38-108-16-16	38-508-16-16	38-208-16-16
38-106-18-16	38-506-18-16	38-206-18-16	18.3 (.719)	13.1 (.516)	14.3 (.563)	15.5 (.609)	18.3 (.719)	38-108-18-16	38-508-18-16	38-208-18-16
38-106-20-16	38-506-20-16	38-206-20-16	19.8 (.781)	14.7 (.578)	15.9 (.625)	17.1 (.672)	19.8 (.781)	38-108-20-16	38-508-20-16	38-208-20-16
38-106-22-16	38-506-22-16	38-206-22-16	21.4 (.844)	16.3 (.641)	17.5 (.688)	18.7 (.734)	21.4 (.844)	38-108-22-16	38-508-22-16	38-208-22-16
38-106-24-16	38-506-24-16	38-206-24-16	23 (.906)	17.9 (.703)	19.1 (.750)	20.3 (.797)	23 (.906)	38-108-24-16	38-508-24-16	38-208-24-16
38-106-26-16	38-506-26-16	38-206-26-16	24.6 (.969)	19.4 (.766)	20.6 (.813)	21.8 (.859)	24.6 (.969)	38-108-26-16	38-508-26-16	38-208-26-16
38-106-28-16	38-506-28-16	38-206-28-16	26.2 (1.031)	21 (.828)	22.2 (.875)	23.4 (.922)	26.2 (1.031)	38-108-28-16	38-508-28-16	38-208-28-16
38-106-30-16	38-506-30-16	38-206-30-16	27.8 (1.094)	22.6 (.891)	23.8 (.938)	25 (.984)	27.8 (1.094)	38-108-30-16	38-508-30-16	38-208-30-16
38-106-32-16	38-506-32-16	38-206-32-16	29.4 (1.156)	24.2 (.953)	25.4 (1.000)	26.6 (1.047)	29.4 (1.156)	38-108-32-16	38-508-32-16	38-208-32-16



LARGE DIAMETER ALUMINUM DRIVE RIVETS

Ø 7.9 (.313)

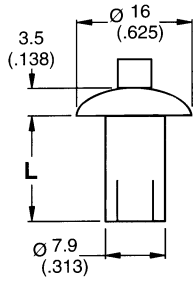

GRIP			L	PART NUMBERS
MIN.	NOM.	MAX.		Universal Head
3.4 (.132)	4.8 (.188)	6.2 (.242)	11.1 (.438)	38-110-06-16
5.7 (.226)	7.1 (.281)	8.5 (.336)	13.5 (.531)	38-110-09-16
8.1 (.320)	9.5 (.375)	10.9 (.430)	15.9 (.625)	38-110-12-16
10.5 (.414)	11.9 (.469)	13.3 (.523)	18.3 (.719)	38-110-15-16
12.9 (.508)	14.3 (.563)	15.7 (.617)	20.6 (.813)	38-110-18-16
15.3 (.601)	16.7 (.656)	18.1 (.711)	23 (.906)	38-110-21-16
17.7 (.695)	19.1 (.750)	20.5 (.804)	25.4 (1.000)	38-110-24-16
20 (.789)	21.4 (.844)	22.8 (.898)	27.8 (1.094)	38-110-27-16
22.4 (.882)	23.8 (.938)	25.2 (.992)	30.2 (1.188)	38-110-30-16
24.8 (.976)	26.2 (1.031)	27.6 (1.086)	32.5 (1.281)	38-110-33-16

Ø 9.5 (.375)

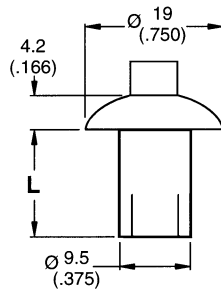

GRIP			L	PART NUMBERS
MIN.	NOM.	MAX.		Universal Head
3.2 (.125)	4.8 (.188)	6.4 (.250)	12.7 (.500)	38-112-06-16
5.5 (.219)	7.1 (.281)	8.7 (.344)	15.1 (.594)	38-112-09-16
7.9 (.313)	9.5 (.375)	11.1 (.438)	17.5 (.688)	38-112-12-16
10.3 (.406)	11.9 (.469)	13.5 (.531)	19.8 (.781)	38-112-15-16
12.7 (.500)	14.3 (.563)	15.9 (.625)	22.2 (.875)	38-112-18-16
15.1 (.594)	16.7 (.656)	18.3 (.719)	24.6 (.969)	38-112-21-16
17.5 (.688)	19.1 (.750)	20.7 (.813)	27 (1.063)	38-112-24-16
19.8 (.781)	21.4 (.844)	23 (.906)	29.4 (1.156)	38-112-27-16
22.2 (.875)	23.8 (.938)	25.4 (1.000)	31.8 (1.250)	38-112-30-16
24.6 (.969)	26.2 (1.031)	27.8 (1.094)	34.1 (1.344)	38-112-33-16



STEEL DRIVE RIVETS

Ø 3.2 (.125)

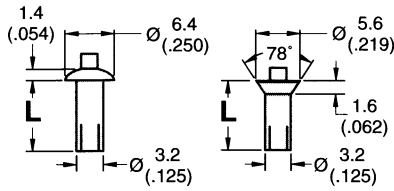

Ø 4.8 (.188)

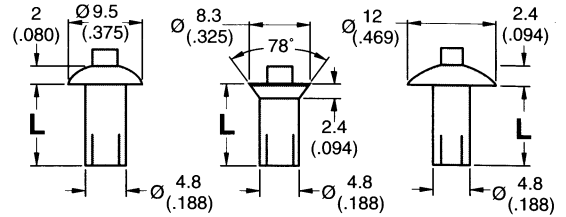

PART NUMBERS		L	GRIP			L	PART NUMBERS		
Universal Head	100° CSK Head		MIN.	NOM.	MAX.		Universal Head	100° CSK Head	Full Brazier Head
38-104-01-93		4 (.156)	0.4 (.016)	0.8 (.031)	1.2 (.047)				
38-104-02-93		4 (.156)	1.2 (.047)	1.6 (.063)	2 (.078)	5.6 (.219)		38-206-02-91	
38-104-03-93	38-604-03-93	4.8 (.188)	2 (.078)	2.4 (.094)	2.8 (.109)	5.6 (.219)	38-106-03-91	38-206-03-91	
38-104-04-93	38-604-04-93	5.6 (.219)	2.8 (.109)	3.2 (.125)	3.6 (.141)	6.4 (.250)	38-106-04-91	38-206-04-91	
38-104-05-93	38-604-05-93	6.4 (.250)	3.6 (.141)	4 (.156)	4.4 (.172)	7.1 (.281)	38-106-05-91	38-206-05-91	
38-104-06-93	38-604-06-93	7.1 (.281)	4.4 (.172)	4.8 (.188)	5.2 (.203)	7.9 (.313)	38-106-06-91	38-606-06-91 38-206-06-91	
38-104-07-93	38-604-07-93	7.9 (.313)	5.2 (.203)	5.6 (.219)	6 (.234)	8.7 (.344)	38-106-07-91	38-606-07-91 38-206-07-91	
38-104-08-93	38-604-08-93	8.7 (.344)	6 (.234)	6.4 (.250)	6.8 (.266)	9.5 (.375)	38-106-08-91	38-606-08-91 38-206-08-91	
38-104-09-93	38-604-09-93	9.5 (.375)	6.8 (.266)	7.1 (.281)	7.5 (.297)	10.3 (.406)	38-106-09-91	38-606-09-91 38-206-09-91	
38-104-10-93	38-604-10-93	10.3 (.406)	7.5 (.297)	7.9 (.313)	8.3 (.328)	11.1 (.438)	38-106-10-91	38-606-10-91 38-206-10-91	
38-104-11-93	38-604-11-93	11.1 (.438)	8.3 (.328)	8.7 (.344)	9.1 (.359)	11.9 (.469)	38-106-11-91	38-606-11-91	
38-104-12-93	38-604-12-93	11.9 (.469)	9.1 (.359)	9.5 (.375)	9.9 (.391)	12.7 (.500)	38-106-12-91	38-606-12-91	
38-104-13-93	38-604-13-93	12.7 (.500)	9.9 (.391)	10.3 (.406)	10.7 (.422)	13.5 (.531)	38-106-13-91	38-606-13-91 38-206-13-91	
38-104-14-93		13.5 (.531)	10.7 (.422)	11.1 (.438)	11.5 (.453)	14.3 (.563)	38-106-14-91	38-606-14-91 38-206-14-91	
			11.5 (.453)	11.9 (.469)	12.3 (.484)	15.1 (.594)	38-106-15-91	38-606-15-91	
			12.3 (.484)	12.7 (.500)	13.1 (.516)	15.9 (.625)	38-106-16-91	38-606-16-91 38-206-16-91	
			13.1 (.516)	13.5 (.531)	13.9 (.547)	16.7 (.656)	38-106-17-91	38-606-17-91	
			13.9 (.547)	14.3 (.563)	14.7 (.578)	17.5 (.688)	38-106-18-91	38-606-18-91	
			14.7 (.578)	15.1 (.594)	15.5 (.609)	18.3 (.719)	38-106-19-91	38-606-19-91	
			15.5 (.609)	15.9 (.625)	16.3 (.641)	19.1 (.750)	38-106-20-91	38-606-20-91 38-206-20-91	

Ø 6.4 (.250)

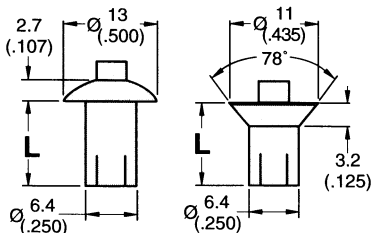

GRIP			L	PART NUMBERS	
MIN.	NOM.	MAX.		Universal Head	78° CSK Head
2 (.078)	2.4 (.094)	2.8 (.109)	5.6 (.219)	38-108-03-91	
2.8 (.109)	3.2 (.125)	3.6 (.141)	6.4 (.250)	38-108-04-91	
3.6 (.141)	4 (.156)	4.4 (.172)	7.1 (.281)	38-108-05-91	
4.4 (.172)	4.8 (.188)	5.2 (.203)	7.9 (.313)	38-108-06-91	38-608-06-91
5.2 (.203)	5.6 (.219)	6 (.234)	8.7 (.344)	38-108-07-91	38-608-07-91
6 (.234)	6.4 (.250)	6.8 (.266)	9.5 (.375)	38-108-08-91	38-608-08-91
6.8 (.266)	7.1 (.281)	7.5 (.297)	10.3 (.406)	38-108-09-91	38-608-09-91
7.5 (.297)	7.9 (.313)	8.3 (.328)	11.1 (.438)	38-108-10-91	38-608-10-91
8.3 (.328)	8.7 (.344)	9.1 (.359)	11.9 (.469)	38-108-11-91	38-608-11-91
9.1 (.359)	9.5 (.375)	9.9 (.391)	12.7 (.500)	38-108-12-91	38-608-12-91
9.9 (.391)	10.3 (.406)	10.7 (.422)	13.5 (.531)	38-108-13-91	38-608-13-91
10.7 (.422)	11.1 (.438)	11.5 (.453)	14.3 (.563)	38-108-14-91	38-608-14-91
11.5 (.453)	11.9 (.469)	12.3 (.484)	15.1 (.594)	38-108-15-91	38-608-15-91
12.3 (.484)	12.7 (.500)	13.1 (.516)	15.9 (.625)	38-108-16-91	38-608-16-91
13.1 (.516)	13.5 (.531)	13.9 (.547)	16.7 (.656)	38-108-17-91	38-608-17-91
13.9 (.547)	14.3 (.563)	14.7 (.578)	17.5 (.688)	38-108-18-91	38-608-18-91
14.7 (.578)	15.1 (.594)	15.5 (.609)	18.3 (.719)	38-108-19-91	38-608-19-91
15.5 (.609)	15.9 (.625)	16.3 (.641)	19.1 (.750)	38-108-20-91	38-608-20-91



STEEL DRIVE RIVETS

Ø 7.9 (.313)

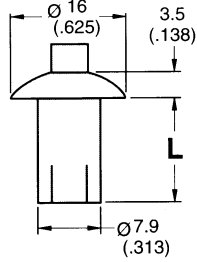

GRIP			L	PART NUMBERS
MIN.	NOM.	MAX.		Universal Head
2.4 (.094)	3.2 (.125)	4 (.156)	7.9 (.313)	38-110-04-91
4 (.156)	4.8 (.188)	5.6 (.219)	9.5 (.375)	38-110-06-91
5.6 (.219)	6.4 (.250)	7.1 (.281)	11.1 (.438)	38-110-08-91
7.1 (.281)	7.9 (.313)	8.7 (.344)	12.7 (.500)	38-110-10-91
8.7 (.344)	9.5 (.375)	10.3 (.406)	14.3 (.563)	38-110-12-91
10.3 (.406)	11.1 (.438)	11.9 (.469)	15.9 (.625)	38-110-14-91
11.9 (.469)	12.7 (.500)	13.5 (.531)	17.5 (.688)	38-110-16-91
13.5 (.531)	14.3 (.563)	15.1 (.594)	19.1 (.750)	38-110-18-91
15.1 (.594)	15.9 (.625)	16.7 (.656)	20.6 (.813)	38-110-20-91
16.7 (.656)	17.5 (.688)	18.3 (.719)	22.2 (.875)	38-110-22-91
18.3 (.719)	19.1 (.750)	19.8 (.781)	23.8 (.938)	38-110-24-91
19.8 (.781)	20.6 (.813)	21.4 (.844)	25.4 (1.000)	38-110-26-91
21.4 (.844)	22.2 (.875)	23 (.906)	27 (1.063)	38-110-28-91
23 (.906)	23.8 (.938)	24.6 (.969)	28.6 (1.125)	38-110-30-91
24.6 (.969)	25.4 (1.000)	26.2 (1.031)	30.2 (1.188)	38-110-32-91

Ø 9.5 (.375)

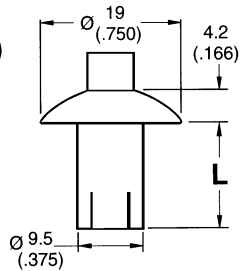

GRIP			L	PART NUMBERS
MIN.	NOM.	MAX.		Universal Head
3.2 (.125)	4.8 (.188)	6.4 (.250)	12.7 (.500)	38-112-06-91
5.6 (.219)	7.1 (.281)	8.7 (.344)	15.1 (.594)	38-112-09-91
7.9 (.313)	9.5 (.375)	11.1 (.438)	17.5 (.688)	38-112-12-91
10.3 (.406)	11.9 (.469)	13.5 (.531)	19.8 (.781)	38-112-15-91
12.7 (.500)	14.3 (.563)	15.9 (.625)	22.2 (.875)	38-112-18-91
15.1 (.594)	16.7 (.656)	18.3 (.719)	24.6 (.969)	38-112-21-91
17.5 (.688)	19.1 (.750)	20.7 (.813)	27 (1.063)	38-112-24-91
19.8 (.781)	21.4 (.844)	23 (.906)	29.4 (1.156)	38-112-27-91
23 (.906)	23.8 (.938)	24.6 (.969)	30.2 (1.188)	38-112-30-91
24.6 (.969)	25.4 (1.000)	26.2 (1.031)	31.8 (1.250)	38-112-32-91



BLIND RIVETS - OPEN END

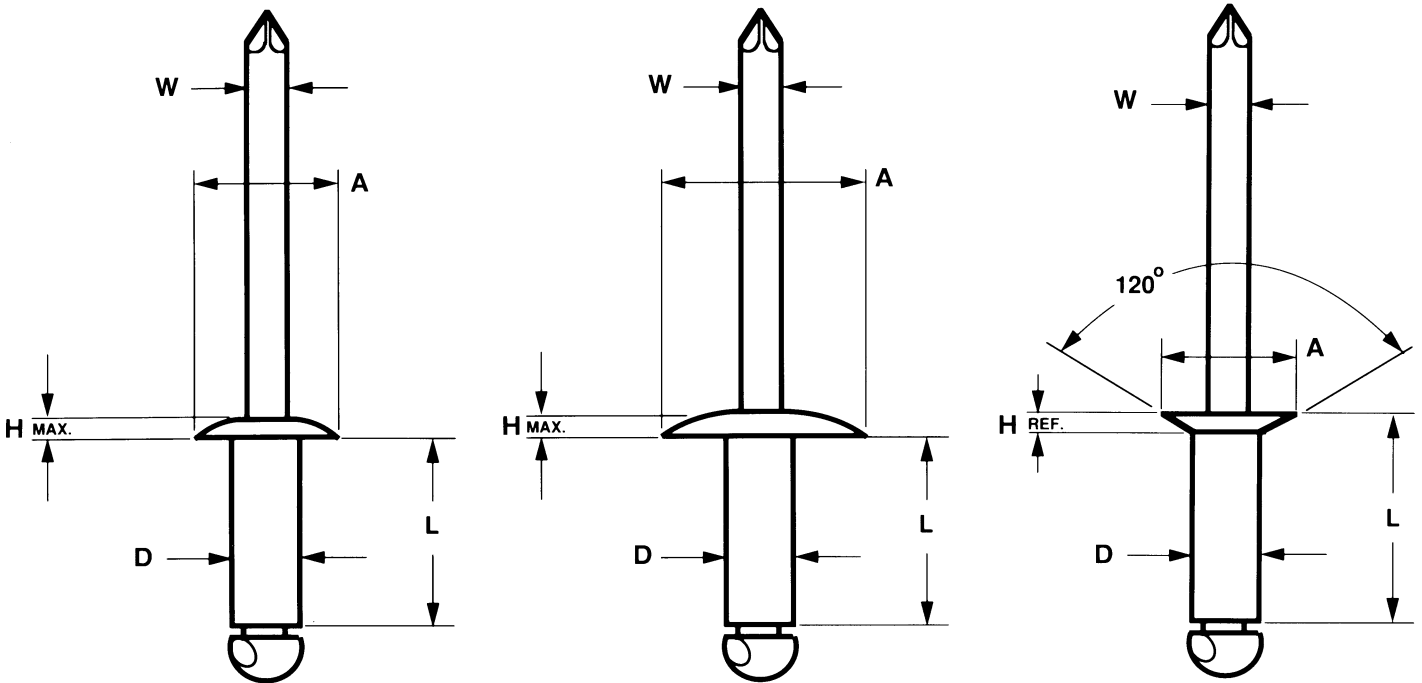

Rivet Series Number	Nominal Rivet Size	D Body Diameter		W Mandrel Diameter	Dome Head		Large Flange		Countersunk Head		Hole Size and Drill Number
		Max.	Min.		A Head Dia.	H Max. Head Height	A Head Dia.	H Max. Head Height	A Head Dia.	H Max. Head Height	
		3	3/32 (2.4mm)		.096	.090	0.057	.187	.032	.281	
4	1/8 (3.2mm)	.128	.122	0.076	.250	.040	.375	.065	.226	.032	.129-.133 (#30)
5	5/32 (4.0mm)	.159	.153	0.095	.312	.050	.469	.075	.281	.040	.160-.164 (#20)
6	3/16 (4.8mm)	.191	.183	0.114	.375	.060	.625	.092	.344	.050	.192-.196 (#11)
8	1/4 (6.4mm)	.255	.246	0.151	.500	.080	.750	.107	.468	.071	.257-.261 (F)

Length varies with each grip length, see pages 16-17
 Values in blue are metric.

PART NUMBERING

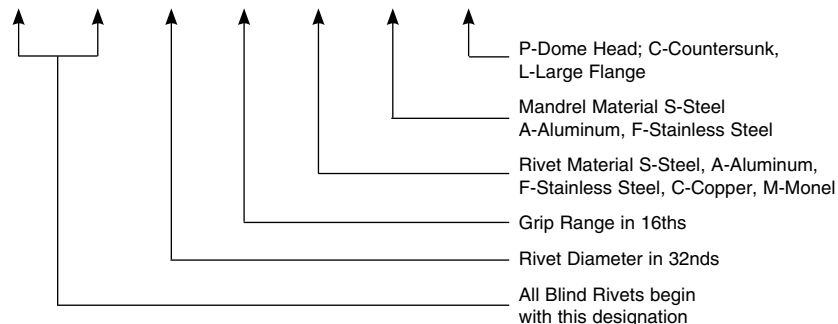
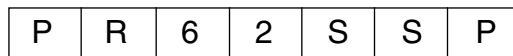



BLIND RIVETS - OPEN END

Rivet Diameter	G Grip Range	L Rivet Lengths Max	Aluminum Rivet Aluminum Mandrel IFI Grade 11					Aluminum Rivet Steel Mandrel IFI Grade 19					Steel Rivet Steel Mandrel IFI Grade 30				
			Dome Head	Large Flange	Countsk. Head	S H E A R	T E N S I L E	Dome Head	Large Flange	Countsk. Head	S H E A R	T E N S I L E	Dome Head	Large Flange	Countsk. Head	S H E A R	T E N S I L E
3/32 (2.4mm)	.020-.125 0.8-3.2mm	.250 6.4mm	32AAP	-	32AAC	70	80	32ASP	-	32ASC	90	120	32SSP	-	32SSC	130	170
	.126-.250 3.3-6.4mm	.375 9.5mm	34AAP	-	34AAC			34ASP	-	34ASC			34SSP	-	34SSC		
	.251-.375 6.5-9.5mm	.500 12.7mm	36AAP	-	36AAC			36ASP	-	36ASC			36SSP	-	36SSC		
1/8 (3.2mm)	.020-.062 0.8-1.6mm	.212 5.4mm	41AAP	-	-	120	150	41ASP	-	41ASC	170	220	41SSP	-	41SSC	260	310
	.063-.125 1.7-3.2mm	.275 7.0mm	42AAP	42AAL	34AAC			42ASP	42ASL	42ASC			42SSP	42SSL	42SSC		
	.126-.187 3.3-4.8mm	.337 8.6mm	43AAP	-	43AAC			43ASP	-	43ASC			43SSP	-	43SSC		
	.188-.250 4.9-6.4mm	.400 10.2mm	44AAP	44AAL	44AAC			44ASP	44ASL	44ASC			44SSP	44SSL	44SSC		
	.251-.312 6.5-7.9mm	.462 11.7mm	45AAP	-	45AAC			45ASP	-	45ASC			45SSP	-	45SSC		
	.313-.375 8.0-9.5mm	.525 13.4mm	46AAP	46AAL	46AAC			46ASP	46ASL	46ASC			46SSP	46SSL	46SSC		
	.376-.500 9.6-12.7mm	.650 16.5mm	48AAP	48AAL	48AAC			48ASP	48ASL	48ASC			48SSP	48SSL	48SSC		
	.501-.625 12.8-15.9mm	.775 19.7mm	410AAP	-	410AAC			410ASP	-	410ASC			410SSP	410SSL	410SSC		
5/32 (4.0mm)	.020-.125 1.6-3.2mm	.300 7.6mm	52AAP	-	-	190	230	52ASP	-	52ASC	260	350	52SSP	-	-	370	470
	.126-.187 3.3-4.8mm	.362 9.2mm	53AAP	-	-			53ASP	-	-			53SSP	-	-		
	.188-.250 4.9-6.4mm	.425 10.8mm	54AAP	54AAL	54AAC			54ASP	54ASL	54ASC			54SSP	54SSL	54SSC		
	.251-.375 6.5-9.5mm	.550 14.0mm	56AAP	56AAL	56AAC			56ASP	56ASL	56ASC			56SSP	56SSL	56SSC		
	.376-.500 9.6-12.7mm	.675 17.2mm	58AAP	58AAL	58AAC			58ASP	58ASL	58ASC			58SSP	58SSL	58SSC		
	.501-.625 12.7-17.1mm	.800 20.3mm	510AAP	-	510AAC			510ASP	-	510ASC			510SSP	-	510SSC		

* ALL PART NUMBERS PRECEDED WITH PR., EXAMPLE PR44SSP

** SPECIALS AVAILABLE UPON REQUEST



BLIND RIVETS – OPEN END

Rivet Diameter	G Grip Range	L Rivet Lengths Max	Aluminum Rivet Aluminum Mandrel IFI Grade 11				Aluminum Rivet Steel Mandrel IFI Grade 19				Steel Rivet Steel Mandrel IFI Grade 30						
			Dome Head	Large Flange	Countsk. Head	S H E A R	T E N S I L E	Dome Head	Large Flange	Countsk. Head	S H E A R	T E N S I L E	Dome Head	Large Flange	Countsk. Head	S H E A R	T E N S I L E
3/16 (4.8mm)	.020-.125 1.6-3.2mm	.325 8.3mm	62AAP	-	-	260	320	62ASP	-	-	380	500	62SSP	-	-	540	680
	.125-.250 3.2-6.4mm	.450 11.5mm	64AAP	64AAL	64AAC			64ASP	64ASL	64ASC			64SSP	64SSL	64SSC		
	.251-.375 6.5-9.5mm	.575 14.6mm	66AAP	66AAL	66AAC			66ASP	66ASL	66ASC			66SSP	66SSL	66SSC		
	.376-.500 9.6-12.7mm	.700 17.8mm	68AAP	68AAL	68AAC			68ASP	68ASL	68ASC			68SSP	68SSL	68SSC		
	.501-.625 12.8-15.9mm	.825 21.0mm	610AAP	610AAL	610AAC			610ASP	610ASL	610ASC			610SSP	610SSL	610SSC		
	.626-.750 16.0-19.1mm	.950 24.2mm	612AAP	612AAL	612AAC			612ASP	612ASL	612ASC			612SSP	612SSL	612SSC		
	.751-.875 19.1-22.2mm	1.075 27.3mm	614AAP	614AAL	614AAC			614ASP	614ASL	614ASC			614SSP	614SSL	614SSC		
	.876-1.000 22.3-25.4mm	1.200 30.5mm	616AAP	-	616AAC			616ASP	-	616ASC			616SSP	-	616SSC		
1/4 (6.4mm)	.020-.125 1.6-3.2mm	.375 9.5mm	82AAP	-	-	460	560	82ASP	-	-	700	920	82SSP	-	-	1000	1240
	.126-.250 3.3-6.4mm	.500 12.7mm	84AAP	84AAL	84AAC			84ASP	84ASL	84ASC			84SSP	84SSL	84SSC		
	.251-.375 6.5-9.5mm	.625 15.9mm	86AAP	86AAL	86AAC			86ASP	86ASL	86ASC			86SSP	86SSL	86SSC		
	.376-.500 9.6-12.7mm	.750 19.1mm	88AAP	88AAL	88AAC			88ASP	88ASL	88ASC			88SSP	88SSL	88SSC		
	.501-.625 12.8-15.9mm	.875 21.0mm	810AAP	810AAL	810AAC			810ASP	810ASL	810ASC			810SSP	810SSL	810SSC		
	.626-.750 16.0-19.1mm	1.000 25.4mm	812AAP	812AAL	812AAC			812ASP	812ASL	812ASC			812SSP	812SSL	812SSC		
	.751-.875 19.1-22.2mm	1.125 28.6mm	814AAP	814AAL	814AAC			814ASP	814ASL	814ASC			814SSP	814SSL	814SSC		
	.876-1.000 22.3-25.4mm	1.250 31.8mm	816AAP	816AAL	816AAC			816ASP	816ASL	816ASC			816SSP	816SSL	816SSC		



BLIND RIVETS - OPEN END

Rivet Diameter	G Grip Range	L Rivet Lengths Max	Stainless Rivet Stainless Mandrel IFI Grade 51					Stainless Rivet Steel Mandrel IFI Grade 50					Copper Rivet Steel Mandrel IFI Grade 20				
			Dome Head	Large Flange	Counts. Head	SHEAR	TENSILE	Dome Head	Large Flange	Counts. Head	SHEAR	TENSILE	Dome Head	Large Flange	Counts. Head	SHEAR	TENSILE
3/32 (2.4mm)	.020-.125 0.8-3.2mm	.250 6.4mm	32FFP	-	32FFC	230	280	32FSP	-	32FSC	230	280	-	-	-		
	.126-.250 3.3-6.4mm	.375 9.5mm	34FFP	-	34FFC			34FSP	-	34FSC			-	-	-		
1/8 (3.2mm)	.020-.062 0.8-1.6mm	.212 5.4mm	41FFP	-	-	420	530	41FSP	-	-	420	530	41CSP	-	-	215	300
	.063-.125 1.7-3.2mm	.275 7.0mm	42FFP	42FFL	42FFC			42FSP	42FSL	42FSC			42CSP	42CSL	42CSC		
	.126-.187 3.3-4.8mm	.337 8.6mm	43FFP	43FFL	43FFC			43FSP	43FSL	43FSC			43CSP	-	43CSC		
	.188-.250 4.9-6.4mm	.400 10.2mm	44FFP	44FFL	44FFC			44FSP	44FSL	44FSC			44CSP	44CSL	44CSC		
	.251-.312 6.5-7.9mm	.462 11.7mm	45FFP	-	45FFC			45FSP	-	45FSC			45CSP	-	45CSC		
	.313-.375 8.0-9.5mm	.525 13.4mm	46FFP	46FFL	46FFC			46FSP	46FSL	46FSC			46CSP	46CSL	-		
	.376-.500 9.6-12.7mm	.650 16.5mm	48FFP	48FFL	-			48FSP	-	-			48CSP	48CSL	48CSC		
	.501-.625 12.8-15.9mm	.775 19.7mm	410FFP	-	-			410FSP	-	-			410CSP	-	410CSC		
5/32 (4.0mm)	.020-.125 1.6-3.2mm	.300 7.6mm	52FFP	-	-	650	820	-	-	-	650	820	-	-	-		
	.126-.187 3.3-4.8mm	.337 8.6mm	53FFP	-	-			-	-	-			-	-			
	.188-.250 4.9-6.4mm	.400 10.2mm	54FFP	54FFL	54FFC			54FSP	54FSL	54FSC			-	-	-		
	.313-.375 8.0-9.5mm	.525 13.4mm	56FFP	56FFL	56FFC			56FSP	56FSL	56FSC			-	-	-		
3/16 (4.8mm)	.020-.125 1.6-3.2mm	.325 8.3mm	62FFP	-	-	950	1200	62FSP	-	-	950	1200	-	-	-		
	.125-.250 3.2-6.4mm	.450 11.5mm	64FFP	64FFL	64FFC			64FSP	64FSL	64FSC			-	-	-		
	.251-.375 6.5-9.5mm	.575 14.6mm	66FFP	66FFL	66FFC			66FSP	66FSL	66FSC			-	-	-		
	.376-.500 9.6-12.7mm	.700 17.8mm	68FFP	68FFL	68FFC			68FSP	68FSL	68FSC			-	-	-		
	.501-.625 12.8-15.9mm	.825 21.0mm	610FFP	610FFL	-			-	-	-			-	-	-		
	.626-.750 16.0-19.1mm	.950 24.2mm	612FFP	612FFL	-			612FSP	612FSL	-			-	-	-		
	.751-.875 19.1-22.2mm	1.075 27.3mm	614FFP	614FFL	-			-	-	-			-	-	-		
	.876-1.00 22.3-25.4mm	1.200 30.5mm	616FFP	616FFL	-			-	-	-			-	-	-		
1/4 (6.4mm)	.020-.125 1.6-3.2mm	.375 9.5mm	82FFP	-	-	1700	2100	82FSP	-	-	1700	2100	-	-	-		
	.126-.250 3.3-6.4mm	.500 12.7mm	84FFP	-	84FFC			84FSP	-	84FSC			-	-			
	.251-.375 6.5-9.5mm	.625 15.9mm	86FFP	-	86FFC			86FSP	-	86FSC			-	-			
	.376-.500 9.6-12.7mm	.750 19.1mm	88FFP	-	88FFC			88FSP	-	88FSC			-	-			
	.501-.625 12.8-15.9mm	.875 21.0mm	810FFP	-	810FFC			810FSP	-	810FSC			-	-			



CLOSED END BLIND RIVETS - DOME HEAD

Dimensions of Dome Head Style Break Mandrel Closed end Blind Rivets (Table 1)

Rivet Series NO.	Nom Rivet Size	D		H		E	R	W	P	F	L
		Body Dia		Style 1 Regular Head		Head Height	Radius of Fillet	Mandrel Dia	Mandrel Protrusion	Blind Side Protrusion	Rivet Body Length
		Max	Min	Max	Min			All Materials			
4	1/8 0.1250	0.128	0.122	0.252	0.224	0.050	0.025	0.074	1.00	Equal "L" Rivet Body Length	See Table 2
5	5/32 0.1562	0.159	0.153	0.328	0.296	0.065	0.025	0.092	1.06		
6	3/16 0.1875	0.191	0.183	0.394	0.356	0.080	0.025	0.110	1.06		
8	1/4 0.2500	0.255	0.246	0.525	0.475	0.100	0.025	0.146	1.06		
See Notes							3			4	

Notes:

* All Dimensions are in inches.

* Recommended drill sizes are those which normally produce holes within the specified hole size limits.

Dome Head Closed-End Blind Rivets

PR-AAPH (Aluminum Rivet / Aluminum Mandrel)

PR-ASPH (Aluminum Rivet / Steel Mandrel)

PR-FFPH (Stainless Steel Rivet / Stainless Steel Mandrel)

Example: **PR64FFPH**

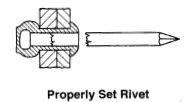
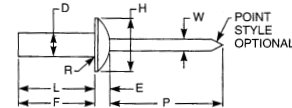

Dome Head

Rivet Series NO.	Nom Rivet Size	Recommended Drill Size	Recommended Hole Size		Rivet No.	Grip Range	Rivet Body Length
			Max	Min			Max
4	1/8 0.1250	#30	0.133	0.129	41	.020-.062	0.297
					42	.063-.125	0.360
					43	.126-.187	0.422
					44	.188-.250	0.485
					45	.251-.312	0.547
5	5/32 0.1562	#20	0.164	0.160	46	.313-.375	0.610
					47	.376-.500	0.735
					52	.020-.125	0.375
					53	.126-.187	0.437
					54	.188-.250	0.500
6	3/16 0.1875	#11	0.196	0.192	55	.251-.312	0.562
					56	.313-.375	0.625
					57	.376-.500	0.750
					62	.020-.125	0.406
					64	.126-.250	0.531
8	1/4 0.2500	F	0.261	0.257	66	.251-.375	0.656
					68	.376-.500	0.781
					610	.501-.625	0.906
					612	.626-.750	1.026
					82	.020-.125	0.445
See Notes	2				84	.126-.250	0.570
					86	.251-.375	0.695
					88	.376-.500	0.820
					810	.501-.625	0.945
					812	.626-.750	1.070
					814	.751-.875	1.195
					816	.876-1.00	1.320

Notes:

* All Dimensions are in inches.

* For application data, see table 2

* The Junction of head shank shall have a fillet with a max radius as shown.

* The blind side protrusion (F) equals the max length of rivet body (L) as given in Table 2 for the applicable grip. Minimum blind side clearance may be calculated by subtracting the actual grip (G) (i.e. the total thickness of material to be joined) from the blind side protrusion (F). (Example: To join two plates each .100 in. thick with a 5/32 in. rivet, a No. 54 rivet would be used. Minimum blind side clearance necessary to permit proper rivet setting would be L-G, which is .500 - .200 and equals .300 in.)



CLOSED END BLIND RIVETS - 120° COUNTERSUNK HEAD

Closed-End Blind Rivets Countersunk Head Specifications

Rivet Series NO.	Nom Rivet Size	D		H		E	R	W	P	F	L
		Body Dia		Style 1 Regular Head		Head Height	Radius of Fillet	Mandrel Dia	Mandrel Protrusion	Blind Side Protrusion	Rivet Body Length
		Max	Min	Max	Min			All Materials			
4	1/8 0.1250	0.128	0.122	0.252	0.221	0.0420	0.025	0.074	1.00	Equal "L" Rivet Body Length	See Table 2
5	5/32 0.1562	0.159	0.153	0.328	0.296	0.051	0.025	0.092	1.06		
6	3/16 0.1875	0.191	0.183	0.394	0.356	0.060	0.025	0.110	1.06		
8	1/4 0.2500	0.255	0.246	0.525	0.475	0.080	0.025	0.146	1.06		
See Notes				3		4				5	

Notes:

- * All Dimensions are in inches.
- * Recommended drill sizes are those which normally produce holes within the specified hole size limits.

Countersunk Head Closed-End Blind Rivets

- PR-AAACH** (Aluminum Rivet / Aluminum Mandrel)
 - PR-ASCH** (Aluminum Rivet / Steel Mandrel)
 - PR-FFCH** (Stainless Steel Rivet / Stainless Steel Mandrel)
- Example: **PR64FFCH**

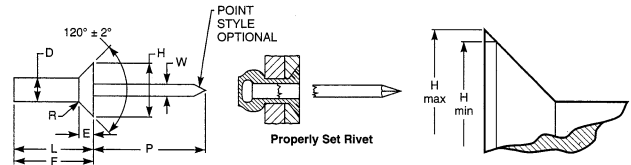

120° Countersunk Head

Rivet Series NO.	Nom Rivet Size	Recommended Drill Size	Recommended Hole Size		Rivet No.	Grip Range	Rivet Body Length
			Max	Min			Max
4	1/8 0.1250	#30	0.133	0.129	41	.031-.062	0.332
					42	.063-.125	0.395
					43	.126-.187	0.457
					44	.188-.250	0.520
					45	.251-.312	0.582
5	5/32 0.1562	#20	0.164	0.160	46	.313-.375	0.645
					47	.376-.500	0.770
					48	.376-.500	0.770
					52	.063-.125	0.425
					53	.126-.187	0.487
6	3/16 0.1875	#11	0.196	0.192	54	.188-.250	0.550
					55	.251-.312	0.612
					56	.313-.375	0.675
					57	.376-.500	0.800
					58	.376-.500	0.800
8	1/4 0.2500	F	0.261	0.257	62	.063-.125	0.471
					63	.126-.250	0.601
					64	.126-.250	0.601
					66	.251-.375	0.736
					68	.376-.500	0.851
See Notes		2			610	.501-.625	1.026
					612	.626-.750	1.101
					82	.020-.125	0.525
					84	.126-.250	0.650
					86	.251-.375	0.775
					88	.376-.500	0.900
					810	.501-.625	1.025
					812	.626-.750	1.150
					814	.751-.875	1.275
					816	.876-1.00	1.400

Notes:

- * All Dimensions are in inches.
- * For application data, see table 2
- * Maximum head diameter is called on nominal rivet diameter and nominal head angle extended to sharp corner. Minimum head diameter is absolute
- * Head Height is given for reference purposes only. Variations in this dimension are controlled by the diameters (H) and (D) and the included angle of the head.
- * The blind side protrusion (F) equals the max length of rivet body (L) as given in Table 2 for the applicable grip. Minimum blind side clearance may be calculated by subtracting the actual grip (G) (i.e. the total thickness of material to be joined) from the blind side protrusion (F). (Example: To join two plates each .100 in. thick with a 5/32 in. rivet, a No. 54 rivet would be used. Minimum blind side clearance necessary to permit proper rivet setting would be L-G, which is .550 - .200 and equals .350 in.)



BULB-TITE® BLIND RIVETS



More than forty years ago the first Bulb-tite was developed to solve application requirements in the Pre-Engineered Metal Building industry. Since that time the Bulb-tite product line has been expanded to meet application requirements in a wide range of industries. The Bulb-tite rivet body folds into three separate legs forming a large blind-side head. This large bearing head evenly distributes the Bulb-tite's high clamp force in soft, thin or brittle materials while providing high pull-through resistance. The Bulb-tite's wide grip range enables a single Bulb-tite to work in a greater variation of thickness. Some versions of the Bulb-tite feature a special flush break mandrel that effectively seals the rivet bore and adds greater shear strength. See note for special installation tool nose tip requirements.*

**Note – Special Bulb-tite installation tool nosepiece is required for use with Bulb-tite rivets: RV6601, RV6603, RV6604, RV6605, RV6606, RV6671, RV6676 and RV6696 series.*

HOW THE BULB-TITE WORKS: During installation the rivet body folds into three separate legs, forming the blind-side upset head. The Bulb-tite mandrel breaks off *flush with the rivet head.

**Flush mandrel break requires use of special Bulb-tite installation tool nose tip.*

WEATHER TIGHT: A special nose tip on the rivet installation tool crimps a crown feature on the rivet head. This crown-cripp effectively seals the rivet bore off from intrusion of dirt and moisture. Adding the optional washer to the Bulb-tite, creates an additional seal around the perimeter of the rivet head, to stop moisture from intruding beneath the rivet head.

HIGH STRENGTH: Another benefit of the Bulb-tite rivet's retained mandrel core is the added strength it provides. Bulb-tite rivets are less prone to failure in high shear loads.

HIGH CLAMPING: The large three-legged upset head evenly distributes the Bulb-tite rivet's high clamp load over a broader bearing surface than do conventional blind rivets. This enables soft, thin, ductile and even brittle materials to be securely clamped without deformation, cracking or other damage to the application.

HARD-TO-FASTEN APPLICATIONS: Bulb-tite rivets function well in materials where other fasteners fail. The folded legs individually conform to curved surfaces enabling fastening onto pipes, corrugations and other challenging shaped applications. Oversized or elongated holes can be adequately covered by the large leg formations to resist pull through under stress in high tension-load applications.

MULTI-GRIP CAPABILITY: Each Bulb-tite handles a wide variation in material thickness. Most sizes fasten over a 1/4" thickness range. Fewer rivet sizes may be required resulting in reduced inventory requirements and simplified fastener selection.

CHOICE OF FINISHED APPEARANCE: Bulb-tite rivets are offered in a variety of head styles. Standard Dome, Low Profile, Large Flange and Countersunk head styles are available. Color matched plastic finish caps can be snapped onto certain Bulb-tite head styles to conceal installed rivet heads. The unique Shaveable Head Bulb-tite was specifically designed for use in heavy truck and trailer applications where solid rivets are used. They are ideal for repair of solid riveted assemblies where access to the application's blind side may be no longer accessible. The Shaveable Bulb-tite rivet head is finished using a special head-shaving tool. Shaved Bulb-tite rivet heads then match the appearance of solid rivets in the assembly.

MATERIAL CHOICES: The standard Bulb-tite rivets are made of aluminum alloy, providing a durable non-rusting fastener that can withstand weather-related corrosion. Some Bulb-tite sizes are also available in steel and monel materials where higher strength is required



BULB-TITE® BLIND RIVETS

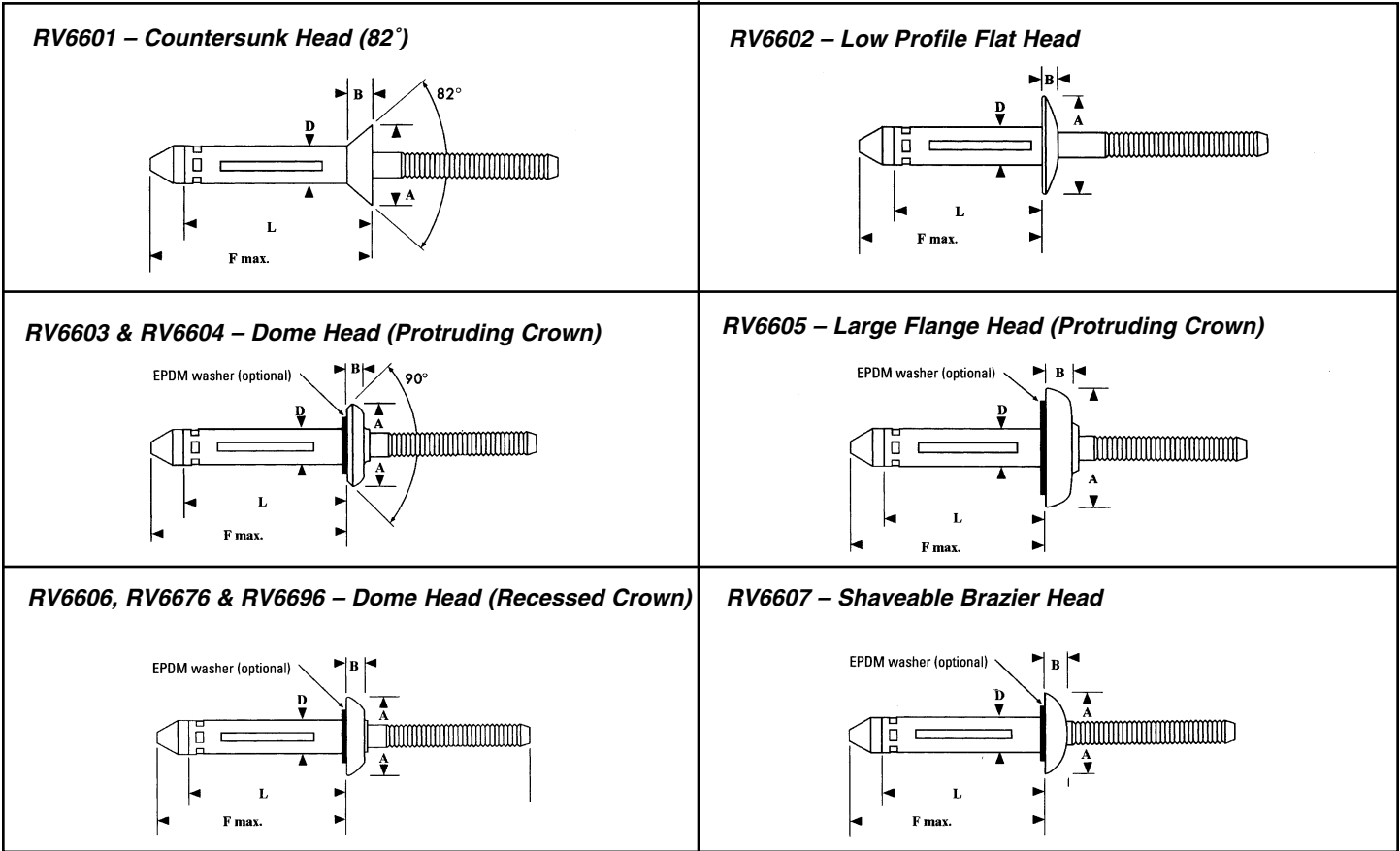

A - Body Diameter • B - Head Height • D - Head Diameter • L - Rivet Body Length • F - Blind Side Protrusion

Aluminum Rivet/Aluminum Mandrel

Head Style	Rivet Dia. Nom.	GESIPA Part Number	Grip Range (Inches)	Hole Sizes Drill No.	Dimensions (Inches)					Typ. Strength (lbs)	
					D	B Max.	A	L Max.	F	Shear	Tensile
Counter Sunk Head	3/16	RV6601-0604	.106-.250	.209-.221 #4	.205	.103	.340	.770	.935	675	450
		RV6601-0606	.187-.375					.895	1.060		
		RV6601-0608	.312-.500					1.020	1.185		
		RV6601-0610	.437-.625					1.145	1.310		
		RV6601-0612	.563-.750					1.270	1.435		
	1/4"	RV6601-0804	.150-.250	.250-.263 1/4	.246	.147	.452	.815	1.005	1100	675
RV6601-0806	.187-.375	.940	1.130								
RV6601-0808	.250-.500	1.065	1.255								
Low Profile Flat Head	5/32"	RV6602-0504	.125-.250	.162-.167 #20	.161	.057	.355-.375	.790	.862	350	225
		RV6602-0506	.187-.375					.852	.987		
		RV6602-0508	.250-.500					.977	1.112		
	3/16"	RV6602-0604	.125-.250	.209-.221 #4	.205	.062	.430-.455	.770	.935	675	450
		RV6602-0606	.187-.375					.895	1.060		
		RV6602-0608	.250-.500					1.020	1.185		
		RV6602-0610	.375-.625					1.145	1.310		
		RV6602-0612	.500-.750					1.270	1.435		
		1/4	RV6602-8-4					.125-.250	.250-.263 1/4		
	RV6602-8-6	.187-.375	.940	1.130							
	RV6602-8-8	.250-.500	1.065	1.255							
	RV6602-8-10	.375-.625	1.190	1.360							



BULB-TITE® BLIND RIVETS

Aluminum Rivet/Aluminum Mandrel

Head Style	Rivet Dia. Nom.	GESIPA Part Number	Grip Range (Inches)	Hole Sizes Drill No.	Dimensions (Inches)					Typ. Strength (lbs)				
					D	B Max.	A	L Max.	F	Shear	Tensile			
Dome Head Protruding Crown	5/32"	RV6604-0504	.067-.250	.162-.167	.161	.074	.343	.805	.925	350	225			
		RV6604-0508	.250-.500	#20								.992	1.112	
	3/16"	RV6604-0603	.050-.187	.209-.221	#4	.205	.125	.443	.895	1.032	675	450		
		RV6604-0604	.062-.250										.707	.844
		RV6604-0606	.187-.375										.770	.907
		RV6604-0608	.312-.500										1.020	1.157
		RV6604-0610	.437-.625										1.145	1.282
	1/4"	RV6604-0612	.563-.750	1.270	1.407									
		RV6604-0804	.062-.250	.250-.263	1/4	.246	.118	.560	.815	1.005	1100	675		
		RV6604-0806	.125-.375										.940	1.130
	RV6604-0808	.250-.500	1.065										1.255	
	9/32"	RV6604-0810	.375-.625	1.190	1.360									
RV6603-0903		.032-.187	.304-.3125	5/16	.304	.150	.615	.863	1.000	1500	1100			
RV6603-0906		.032-.375										1.110	1.325	
RV6603-0910	.250-.625	1.360										1.575		
Large Flange Prot. Crown	9/32"	RV6603-0912	.375-.750	1.485	1.700									
		RV6605-0906	.042-.375	.308-.327	5/16	.304	.150	.743	1.110	1.325	1500	1100		
		RV6605-0910	.250-.625										1.360	1.575
RV6605-0912	.375-.750	1.485	1.700											
Low Profile Head Recessed Crown	3/16"	RV6606-0603	.050-.187	.209-.221	.205	.099	.469	.895	1.032	675	450			
		RV6606-0604	.062-.250									.707	.844	
		RV6606-0606	.187-.375									.770	.907	
		RV6606-0608	.312-.500									1.020	1.157	
		RV6606-0610	.437-.625									1.145	1.282	
	1/4"	RV6606-0612	.563-.750	1.270	1.407									
		RV6606-0804	.040-.250	.250-.263	1/4	.246	.116	.543	.815	1.005	1100	675		
		RV6606-0806	.125-.375										.940	1.130
		RV6606-0808	.250-.500										1.065	1.255
		RV6606-0810	.375-.625										1.190	1.380

Steel Rivet/Steel Mandrel

Countersunk Head	1/4"	RV6671-0804	.150-.250	.250-.263	.246	.147	.477-.485	.915	1.005	1250	950		
		RV6671-0806	.187-.375									1.040	1.130
		RV6671-0808	.250-.500									1.165	1.355
Dome Head Recessed Crown	1/4"	RV6676-0804	.040-.250	.250-.263	.246	.116	.535-.550	.815	1.005	1250	950		
		RV6676-0806	.125-.375									.940	1.130
		RV6676-0808	.250-.500									1.065	1.255
		RV6676-0810	.375-.625									1.190	1.380

Monel Rivet/Stainless Steel Mandrel

Dome Head Recessed Crown	1/4"	RV6696-0804	.040-.250	.250-.263	.246	.116	.535-.550	.815	1.005	2100	1455		
		RV6696-0806	.125-.375									1.045	1.255
		RV6696-0808	.250-.500									1.170	1.380
		RV6696-0810	.375-.625										

Part Number Identification

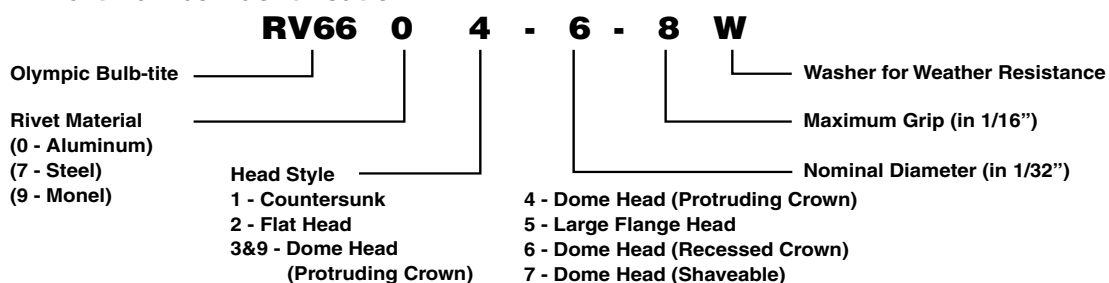



BULB-TITE® BLIND RIVETS

Aluminum Rivet/Aluminum Mandrel

Head Style	Rivet Dia. Nom.	GESIPA Part Number	Grip Range (Inches)	Hole Sizes Drill No.	Dimensions (Inches)					Typ. Strength (lbs)	
					D	B Max.	A	L Max.	F	Shear	Tensile
Shaveable Brazier Head	5/32"	RV6607-0505	.020-.312	.162-.167 #20	.161	.077	.296-.328	.800	.920	350	225
	3/16"	RV6607-0603	.020-.187	.209-.221	.205	.105	.446-.492	.707	.872	675	450
		RV6607-0604	.050-.250	#4				.770	.935		
		RV6607-0606	.050-.375	.895				1.060			
		RV6607-0608	.040-.500	1.020				1.185			
		RV6607-0610	.050-.625	1.145				1.310			
	RV6607-0612	.050-.750	1.270	1.435							
1/4"	RV6607-0808	.050-.500	.250-.263 1/4	.246	.120	.469	1.045	1.255	1100	675	

Shaveable Series

The Shaveable series of Bulb-tite rivets are designed for use in applications where solid "bucked" type rivets are commonly used such as truck/trailer body assembly or repair. The Shaveable Bulb-tite simplifies repairs made to solid riveted assemblies, as rivet replacement does not require access to the blind side of the application. The Bulb-tite's large blindside footprint functions well in rivet holes that have become elongated or too large to allow use of a solid rivet. Simply install the Bulb-tite and finish the rivet head with an Olympic head-shaving tool. The shaved head profile perfectly matches the solid brazier head rivets used elsewhere in the assembly. Shaveable Bulb-tites are available in 5/32", 3/16" and 1/4" diameters and can be installed with most standard blind rivet tools. A special tool nose tip is not required. The installed rivet's mandrel is designed to break high, leaving an exposed mandrel plug extending above the set fastener's head. The remaining mandrel protrusion is snipped off using the RV57 mandrel trimming tool. Finally, the rivet head is shaved using the HS310 rivet head shaver, leaving a finished rivet head that matches solid rivets in appearance.





Q[®] RIVET



Internal friction lock with positive retention. Good shear strength. Provides moderate hole fill and a weather-resistant feature. Available in a variety of materials and headstyles.

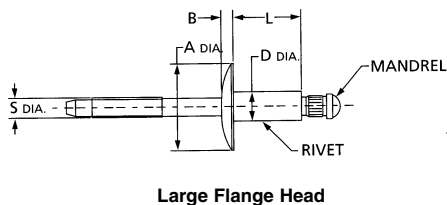
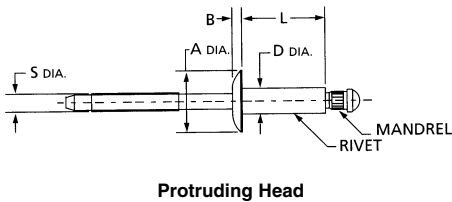
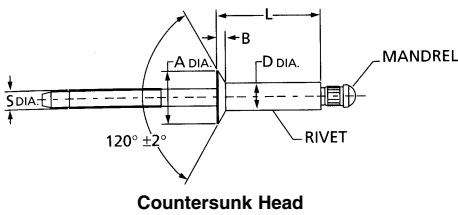
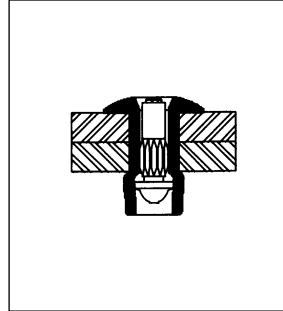

Nom. Rivet Diam.	Hole Size & Drill No.	S Mand. Diam.	D Rivet Diam.	Protruding		Large Flange		Countersunk	
				A Head Diam.	B Max. Head Thick.	A Head Diam.	B Max. Head Thick.	A Head Diam.	B Ref. Head Thick.
1/8" (3.2mm)	.129-.133 (#30) (3.28-3.38)	.075 (1.91)	.125 (3.18)	.250 (6.35)	.042 (1.07)	.375 (9.53)	.065 (1.65)	.226 (5.74)	.032 (0.81)
5/32" (4.0mm)	.160-.164 (#20) (4.06-4.17)	.094 (2.39)	.156 (3.96)	.312 (7.920)	.050 (1.27)	.469 (11.91)	.075 (1.91)	.281 (7.14)	.040 (1.02)
3/16" (4.8mm)	.192-.196 (#11) (4.88-4.98)	.114 (2.90)	.187 (4.75)	.375 (9.53)	.060 (1.52)	.625 (15.88)	.092 (2.34)	.344 (8.74)	.050 (1.27)
1/4" (6.4mm)	.257-.261 (F) (6.53-6.63)	.151 (3.84)	.250 (6.35)	.500 (12.70)	.080 (1.96)	.750 (19.50)	.107 (2.72)	.468 (11.89)	.071 (1.80)

*L - Length varies with each grip length (see following pages).
(1) Mandrels may be either smooth or serrated, manufacturer's option.

Rivet Shear and Tensile Strength lbs. f (N) Tested per IFI 135 Q [®] Rivet								
Rivet Diam.	Series AA Alum. Rivet Alum. Mand.		Series AS Alum. Rivet Steel Mand.		Series SS Steel Rivet Steel Mand.		Series FF Stain. Rivet Stain. Mand.	
	Shear	Tens.	Shear	Tens.	Shear	Tens.	Shear	Tens.
1/8" (3.2mm)	225 (1001)	250 (1112)	350 (1557)	325 (1445)	500 (2224)	400 (1779)	700 (3114)	600 (2669)
5/32" (4.0mm)	325 (1445)	325 (1445)	525 (2335)	450 (2002)	700 (3114)	550 (2446)	1050 (4670)	1000 (4448)
3/16" (4.8mm)	500 (2224)	450 (2002)	750 (3336)	650 (2891)	1050 (4670)	825 (3670)	1650 (7339)	1300 (5782)
1/4" (6.4mm)	850 (3781)	750 (3336)	1250 (5560)	1050 (4670)	1750 (7784)	1450 (6450)	2450 (10898)	2250 (10008)



Q[®] RIVET

AAPQ-06-08

IDENTIFICATION CODE:

First letter is rivet material:

A = 5052 Aluminum **A** = 5056 Aluminum **F** = Stainless **S** = Steel

Second letter is mandrel material:

A = 7178 Aluminum **S** = Steel **F** = Stainless

Third letter is head style:

P = Protruding **L** = Large Flange **C** = Countersunk

Fourth letter is type of rivet:

Q = Q Rivet, structural, self-plugging

First number is rivet diameter in 32nds of an inch. For example, 06 is 6/32nds or 3/16" diameter

Second number is rivet maximum grip length in 16th of an inch. For example, 08 is 8/16th or 1/2" grip length

Rivet Diam.	G Grip Range			L Rivet Length Max.	Series AA Aluminum Rivet Aluminum Mandrel			Series AS Aluminum Rivet Steel Mandrel, Plated		
	Min.	Mid.*	Max.		Prot. Head	Lrg. Head	Ctsk. Head	Prot. Head	Lrg. Head	Ctsk. Head
1/8" (3.2mm)			.062 (1.57)	.212 (5.38)	AAPQ-04-01			ASPQ-04-01		
	0.63 (1.60)	.093 (2.36)	.125 (3.18)	.275 (6.99)	AAPQ-04-02	AALQ-04-02		ASPQ-04-02	ASLQ-04-02	
	.094 (2.39)	.125 (3.18)	.187 (4.75)	.337 (8.56)	AAPQ-04-03		AACQ-04-03	ASPQ-04-03		ASCQ-04-03
	.126 (3.20)	.187 (4.75)	.250 (6.35)	.400 (10.16)	AAPQ-04-04	AALQ-04-04	AACQ-04-04	ASPQ-04-04	ASLQ-04-04	ASCQ-04-04
	.188 (4.78)	.250 (6.35)	.312 (7.92)	.462 (11.73)	AAPQ-04-05		AACQ-04-05	ASPQ-04-05		ASCQ-04-05
	.251 (6.38)	.312 (7.92)	.375 (9.53)	.535 (13.59)	AAPQ-04-06	AALQ-04-06	AACQ-04-06	ASPQ-04-06	ASLQ-04-06	ASCQ-04-06
	.313 (7.95)	.375 (9.53)	.437 (11.10)	.602 (15.29)	AAPQ-04-07		AACQ-04-07	ASPQ-04-07		ASCQ-04-07
	.376 (9.55)	.437 (11.10)	.500 (12.70)	.670 (17.02)	AAPQ-04-08	AALQ-04-08	AACQ-04-08	ASPQ-04-08		ASCQ-04-08
5/32" (4.0mm)	.062 (1.57)	.093 (2.36)	.125 (3.18)	.300 (7.62)	AAPQ-05-02			ASPQ-05-02	ASLQ-05-02	
	.126 (3.20)	.187 (4.75)	.250 (6.35)	.425 (10.80)	AAPQ-05-04	AALQ-05-04	AACQ-05-04	ASPQ-05-04	ASLQ-05-04	ASCQ-05-04
	.251 (6.38)	.312 (7.92)	.375 (9.53)	.550 (13.97)	AAPQ-05-06	AALQ-05-06	AACQ-05-06	ASPQ-05-06	ASLQ-05-06	ASCQ-05-06
	.376 (9.55)	.437 (11.10)	.500 (12.70)	.675 (17.65)	AAPQ-05-08	AALQ-05-08	AACQ-05-08	ASPQ-05-08	ASLQ-05-08	ASCQ-05-08
3/16" (4.8mm)	.062 (1.57)	.093 (2.36)	.125 (3.18)	.325 (8.26)	AAPQ-06-02			ASPQ-06-02		
	.126 (3.20)	.187 (4.75)	.250 (6.35)	.450 (11.43)	AAPQ-06-04	AALQ-06-04	AACQ-06-04	ASPQ-06-04		ASCQ-06-04
	.251 (6.38)	.312 (7.92)	.375 (9.53)	.575 (14.61)	AAPQ-06-06	AALQ-06-06	AACQ-06-06	ASPQ-06-06	ASLQ-06-06	ASCQ-06-06
	.376 (9.55)	.437 (11.10)	.500 (12.70)	.700 (17.78)	AAPQ-06-08	AALQ-06-08	AACQ-06-08	ASPQ-06-08	ASLQ-06-08	ASCQ-06-08
	.501 (12.73)	.562 (14.27)	.625 (15.88)	.850 (21.59)	AAPQ-06-10	AALQ-06-10	AACQ-06-10	ASPQ-06-10	ASLQ-06-10	ASCQ-06-10
	.626 (15.90)	.687 (17.45)	.750 (19.05)	.980 (24.89)	AAPQ-06-12	AALQ-06-12	AACQ-06-12	ASPQ-06-12	ASLQ-06-12	ASCQ-06-12
	.751 (19.08)	.812 (20.62)	.875 (22.23)	1.11 (28.19)	AAPQ-06-14	AALQ-06-14	AACQ-06-14	ASPQ-06-14	ASLQ-06-14	ASCQ-06-14
1/4" (6.4mm)	.062 (1.57)	.093 (2.36)	.125 (3.18)	.375 (9.53)	AAPQ-08-02			ASPQ-08-02		
	.126 (3.20)	.187 (4.75)	.250 (6.35)	.500 (12.70)	AAPQ-08-04	AALQ-08-04	AACQ-08-04	ASPQ-08-04	ASLQ-08-04	ASCQ-08-04
	.251 (6.38)	.312 (7.92)	.375 (9.53)	.625 (15.88)	AAPQ-08-06	AALQ-08-06	AACQ-08-06	ASPQ-08-06	ASLQ-08-06	ASCQ-08-06
	.376 (9.55)	.437 (11.10)	.500 (12.70)	.750 (19.05)	AAPQ-08-08	AALQ-08-08	AACQ-08-08	ASPQ-08-08	ASLQ-08-08	ASCQ-08-08
	.501 (12.73)	.562 (14.27)	.625 (15.88)	.900 (22.86)	AAPQ-08-10	AALQ-08-10	AACQ-08-10	ASPQ-08-10	ASLQ-08-10	ASCQ-08-10
	.626 (15.90)	.687 (17.45)	.750 (19.05)	1.03 (26.16)	AAPQ-08-12	AALQ-08-12	AACQ-08-12	ASPQ-08-12	ASLQ-08-12	ASCQ-08-12
	.751 (19.08)	.812 (20.62)	.875 (22.23)	1.16 (29.46)	AAPQ-08-14	AALQ-08-14	AACQ-08-14	ASPQ-08-14	ASLQ-08-14	ASCQ-08-14
	.876 (22.25)	.937 (23.80)	1.00 (25.40)	1.29 (32.77)	AAPQ-08-16	AALQ-08-16	AACQ-08-16	ASPQ-08-16	ASLQ-08-16	ASCQ-08-16



NOTE: ITEMS LISTED ON THESE PAGES REFLECT OUR MANUFACTURING CAPABILITY.

Series SS Steel Rivet, Plated Steel Mandrel, Plated			Series FF Stainless Rivet Stainless Mandrel		
Prot. head	Lrg. head	Ctsk. head	Prot. head	Lrg. head	Ctsk. head
SSPQ-04-01			FFPQ-04-01		
SSPQ-04-02	SSLQ-04-02		FFPQ-04-02	FFLQ-04-02	
SSPQ-04-03		SSCQ-04-03	FFPQ-04-03		FFCQ-04-03
SSPQ-04-04	SSLQ-04-04	SSCQ-04-04	FFPQ-04-04	FFLQ-04-04	FFCQ-04-04
SSPQ-04-05		SSCQ-04-05	FFPQ-04-05		FFCQ-04-05
SSPQ-04-06	SSLQ-04-05	SSCQ-04-06	FFPQ-04-06	FFLQ-04-06	FFCQ-04-06
SSPQ-04-07		SSCQ-04-07			
SSPQ-04-08	SSLQ-04-08	SSCQ-04-08			
SSPQ-05-02			FFPQ-05-02		
SSPQ-05-04	SSLQ-05-04	SSCQ-05-04	FFPQ-05-04	FFLQ-05-04	FFCQ-05-04
SSPQ-05-06	SSLQ-05-06	SSCQ-05-06	FFPQ-05-06	FFLQ-05-06	FFCQ-05-06
SSPQ-05-08	SSLQ-05-08	SSCQ-05-08			
SSPQ-06-02			FFPQ-06-02		
SSPQ-06-04	SSLQ-06-04	SSCQ-06-04	FFPQ-06-04	FFLQ-06-04	FFCQ-06-04
SSPQ-06-06	SSLQ-06-06	SSCQ-06-06	FFPQ-06-06	FFLQ-06-06	FFCQ-06-06
SSPQ-06-08	SSLQ-06-08	SSCQ-06-08	FFPQ-06-08	FFLQ-06-08	FFCQ-06-08
SSPQ-06-10	SSLQ-06-10	SSCQ-06-10			
SSPQ-06-12	SSLQ-06-12	SSCQ-06-12			
SSPQ-08-02			FFPQ-08-02		
SSPQ-08-04	SSLQ-08-04	SSCQ-08-04	FFPQ-08-04		FFCQ-08-04
SSPQ-08-06	SSLQ-08-06	SSCQ-08-06	FFPQ-08-06		FFCQ-08-06
SSPQ-08-08	SSLQ-08-08	SSCQ-08-08	FFPQ-08-08		FFCQ-08-08
SSPQ-08-10	SSLQ-08-10	SSCQ-08-10	FFPQ-08-10		FFCQ-08-10
SSPQ-08-12	SSLQ-08-12	SSCQ-08-12			
SSPQ-08-14	SSLQ-08-14	SSCQ-08-14			
SSPQ-08-16	SSLQ-08-16	SSCQ-08-16			



BLIND RIVETS: AVINOX II RIVETS

The Avinox® stainless steel rivet offers a high-strength fastening solution ideal for thin sheet metals. The stainless steel breakstem provides excellent bulbing tail formation and high shear and tensile strength. This industrial fastener's stainless steel construction provides good corrosion resistance in applications subject to elevated temperatures.

Key features and benefits

- High corrosion resistance
- High shear and tensile strength
- Good hole fill
- Provides a large blind side bearing area against the rear sheet
- Retained stem
- Ideal for applications requiring elevated temperatures
- Spreads the tail bearing load/clamp load on the rear sheet
- Ideal for use in thin sheet materials
- Compensates for irregular, oversized, slotted or misaligned holes
- Can stop movement in non-standard holes
- Provides strong, vibration resistant joints
- No damage, electrical problems or rattling due to loose stems

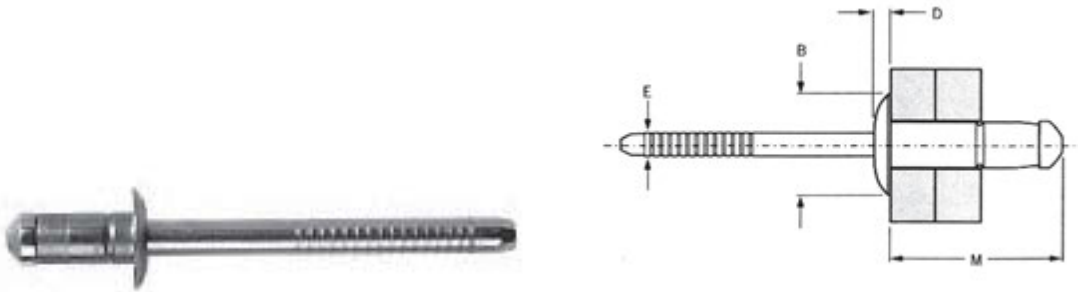

Rivet Material Mandrel Material	Head style	Part Number	Body Diameter	Work Hole Diameter	Grip Range	Body Length (Max.)	Head Diameter (Nom.)	Head Height (Max.)	Typical Ultimate Strengths in LBS. (See Note)		
			"A"	"H"	"G"	"M"	"B"	"D"	Shear		Tensile
									Stem Inside Shear Plane	Stem Outside Shear Plane	
	Lo-Profile Head	PR42FFPA	.122/.130	.130/.134	.039-.118	.350	.248	.043	360	360	450
		PR43FFPA	.122/.130	.130/.134	.118-.197	.450	.248	.043	382	360	450
		PR44FFPA	.122/.130	.130/.134	.197-.276	.540	.248	.043	719	360	450
		PR52FFPA	.153/.160	.161/.169	.039-.118	.400	.303	.059	1169	629	899
		PR53FFPA	.153/.160	.161/.169	.118-.197	.480	.303	.059	1169	629	899
		PR54FFPA	.153/.160	.161/.169	.197-.276	.600	.303	.059	1169	629	899
		PR63FFPA	.183/.191	.193/.201	.059-.138	.510	.366	.059	1236	877	1124
		PR64FFPA	.183/.191	.193/.201	.138-.236	.610	.366	.059	1236	877	1124
		PR65FFPA	.183/.191	.193/.201	.236-.335	.730	.366	.059	1236	877	1124

NOTE: Values for typical ultimate strengths are a guide only and may vary greatly depending upon the application.



JC-LOCK BLIND RIVETS

The JC-Lock is a structural blind rivet with a wide grip range, high strength and water resistant.

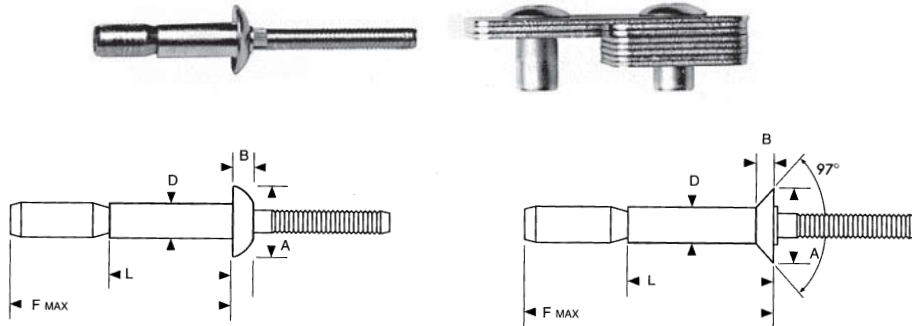

Steel Rivet/Steel Mandrel Product Specifications

Head Style	Rivet Dia. Nom.	JAY-CEE Part Number	Grip Range (Inches)	Hole Sizes Drill No.	Dimensions (Inches)					Min. Strength (lbs)		
					D	B Max.	A	L Max.	F	Shear	Tensile	Mandrel Pushout
Dome	3/16"	PR64SSPI	.062-.270	.194-.204	.185-.188	0.088	.353-.373	0.415	0.675	1300	1200	150
		PR67SSPI	.214-.437					0.572	0.825			
		PR67SSPIE	.062-.437	#8				0.572	0.95			
	1/4"	PR86SSPI	.080-.375	.261-.272	.253-.257	0.116	.480-.500	0.56	0.97	2500	2220	300
		PR810SSPI	.350-.625					0.81	1.22			
		PR810SSPIE	.080-.625	H				0.81	1.405			
Counter-sunk	3/16"	PR66SSCI	.125-.331	.194-.204	.185-.188	0.072	.321-.338	0.486	0.8	1300	1200	150
		PR68SSCI	.275-.500	#8	Ref.			0.606	1.032			
	1/4"	PR87SSCI	.125-.437	.261-.272	.253-.257	Ref.	.410-.422	0.079	0.66	2500	2200	300
								H	1.2			

Aluminum Rivet/Aluminum Mandrel Product Specifications

Head Style	Rivet Dia. Nom.	JAY-CEE Part Number	Grip Range (Inches)	Hole Sizes Drill No.	Dimensions (Inches)					Min. Strength (lbs)		
					D	B Max.	A	L Max.	F	Shear	Tensile	Mandrel Pushout
Dome	3/16"	PR64AAPI	.062-.270	.194-.204	.185-.188	0.088	.353-.373	0.415	0.675	600	500	50
		PR67AAPI	.214-.437					0.572	0.825			
		PR67AAPIE	.062-.437	#8				0.572	0.95			
	1/4"	PR86AAPI	.080-.375	.261-.272	.253-.257	0.116	.480-.500	0.56	0.97	1300	890	100
		PR810AAPI	.350-.625					0.81	1.22			
		PR810AAPIE	.080-.625	H				0.81	1.405			
Counter-sunk	3/16"	PR66AACI	.125-.331	.194-.204	.185-.188	0.072	.321-.338	0.486	0.8	600	500	50
		PR68AACI	.275-.500	#8	Ref.			0.606	1.032			
	1/4"	PR87AACI	.125-.437	.261-.272	.253-.257	Ref.	.410-.422	0.079	0.66	1300	890	100
								H	1.2			

Stainless Steel Rivet/Stainless Steel Mandrel Product Specifications

Head Style	Rivet Dia. Nom.	JAY-CEE Part Number	Grip Range (Inches)	Hole Sizes Drill No.	Dimensions (Inches)					Min. Strength (lbs)		
					D	B Max.	A	L Max.	F	Shear	Tensile	Mandrel Pushout
Dome	3/16"	PR64FFPI	.062-.270	.194-.204	.185-.188	0.088	.353-.373	0.415	0.675	1300	950	100
		PR67FFPIE	.062-.437	#8				0.572	0.825			
	1/4"	PR86FFPI	.080-.375	.261-.272	.253-.257	0.116	.480-.500	0.56	1.025	2350	1800	200
		PR810FFPIE	.080-.625	H				0.81	1.355			
Counter-sunk	3/16"	PR66FFCI	.125-.331	.194-.204	.185-.188	REF.	.321-.338	0.486	0.8	1300	950	100
		PR68FFCI	.275-.500	#8	REF.			0.606	1.032			
	1/4"	PR87FFCI	.125-.437	.261-.272	.253-.257	Ref.	.410-.422	0.079	0.66	2350	1800	200
								H	1.2			



2 PIECE MATE RIVETS

2 Piece Mate Rivets

A two-piece Non-Structural fastening rivet system for extra-long grip applications.

Benefits:

- * Extra Wide Grip Range: Can be used in thickness up to nearly 4 inches.
- * Controlled Clamp Up: Clamps securely without crushing parent material.
- * Non-Critical: Not necessary to have close-tolerance hole preparation.
- * Dimensional Data

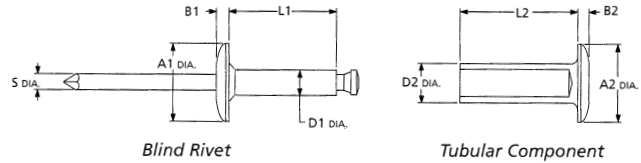

Nom. Rivet Diam.	Hole Size and Drill Number	Blind Rivet				Tubular Comp.		
		Mand Diam.	Rivet Diam.	Head Diam.	Head Thick	Rivet Diam.	Head Diam.	Head Thick
3/16" (4.8mm)	.250 (5.4)	.076 (1.9)	.125 (3.2)	.375 (9.5)	.059 (1.5)	.188 (4.8)	.375 (9.5)	.057 (1.)
1/4" (6.5mm)	.312 (7.9)	.114 (2.9)	.187 (4.8)	.625 (15.9)	.095 (2.4)	.250 (6.4)	.625 (15.9)	.095 (2.4)

Rivet Diam.	Grip Range	L1 Rivet Length (Max.)	L2 Comp. Length (Max.)	Blind Rivet Alum. Sleeve Alum. Mandrel Tubular Comp. Aluminum	Blind Rivet Steel Sleeve Plated Steel Mandrel Plated Tubular Comp. Steel Plated	Blind Rivet Alum. Sleeve Steel Mandrel Plated Tubular Comp. Aluminum
3/16" (4.8mm)	5/8 to 3/4	.525 (13.3)	.585 (14.9)	BALM-6BP-12	SSLM-6SP-12	BSLM-6BP-12
	11/16 to 7/8	.525 (13.3)	.647 (16.4)	BALM-6BP-14	SSLM-6SP-14	BSLM-6BP-14
	7/8 to 1-1/16	.525 (13.3)	.825 (21.0)	BALM-6BP-17	SSLM-6SP-17	BSLM-6BP-17
	1-1/16 to 1-1/4	.525 (13.3)	1.012 (25.7)	BALM-6BP-20	SSLM-6SP-20	BSLM-6BP-20
	1-1/4 to 1-7/16	.525 (13.3)	1.200 (30.5)	BALM-6BP-23	SSLM-6SP-23	BSLM-6BP-23
	1-7/16 to 1-5/8	.525 (13.3)	1.387 (35.2)	BALM-6BP-26	SSLM-6SP-26	BSLM-6BP-26
	1-5/8 to 1-13/16	.525 (13.3)	1.575 (40.0)	BALM-6BP-29	SSLM-6SP-29	BSLM-6BP-29
	1-13/16 to 2	.525 (13.3)	1.762 (44.8)	BALM-6BP-32	SSLM-6SP-32	BSLM-6BP-32
	2 to 2-3/16	.525 (13.3)	1.950 (49.5)	BALM-6BP-35	SSLM-6SP-35	BSLM-6BP-35
2-3/16 to 2-3/8	.525 (13.3)	2.137 (54.3)	BALM-6BP-38	SSLM-6SP-38	BSLM-6BP-38	
1/4" (6.4mm)	5/8 to 3/4	.454 (11.5)	.580 (14.7)	BALM-8BP-12	SSLM-8SP-12	BSLM-8BP-12
	3/4 to 7/8	.608 (15.4)	.695 (17.7)	BALM-8BP-14	SSLM-8SP-14	BSLM-8BP-14
	7/8 to 1-1/8	.608 (15.4)	.820 (20.8)	BALM-8BP-18	SSLM-8SP-18	BSLM-8BP-18
	1-1/8 to 1-3/8	.608 (15.4)	1.070 (27.2)	BALM-8BP-22	SSLM-8SP-22	BSLM-8BP-22
	1-3/8 to 1-5/8	.608 (15.4)	1.320 (33.5)	BALM-8BP-26	SSLM-8SP-26	BSLM-8BP-26
	1-5/8 to 1-7/8	.608 (15.4)	1.570 (39.9)	BALM-8BP-30	SSLM-8SP-30	BSLM-8BP-30
	1-7/8 to 2-1/8	.608 (15.4)	1.820 (46.2)	BALM-8BP-34	SSLM-8SP-34	BSLM-8BP-34
	2-1/8 to 2-3/8	.608 (15.4)	2.070 (52.6)	BALM-8BP-38	SSLM-8SP-38	BSLM-8BP-38
	2-3/8 to 2-5/8	.608 (15.4)	2.320 (58.9)	BALM-8BP-42	SSLM-8SP-42	BSLM-8BP-42
	2-5/8 to 2-7/8	.608 (15.4)	2.570 (65.3)	BALM-8BP-46	SSLM-8SP-46	BSLM-8BP-46
	2-7/8 to 3-1/8	.608 (15.4)	2.820 (71.6)	BALM-8BP-50	SSLM-8SP-50	BSLM-8BP-50
	3-1/8 to 3-3/8	.608 (15.4)	3.070 (78.0)	BALM-8BP-54	SSLM-8SP-54	BSLM-8BP-54
	3-3/8 to 3-5/8	.608 (15.4)	3.320 (84.3)	BALM-8BP-58	SSLM-8SP-58	BSLM-8BP-58
	3-5/8 to 3-7/8	.608 (15.4)	3.570 (90.7)	BALM-8BP-62	SSLM-8SP-62	BSLM-8BP-62
Typical Tensile Values for 1/4 diam. only.				250 lb.	350 lbs.	450 lb.

Note: This table reflects typical results in test parameters.



MULTIGRIP BLIND RIVETS

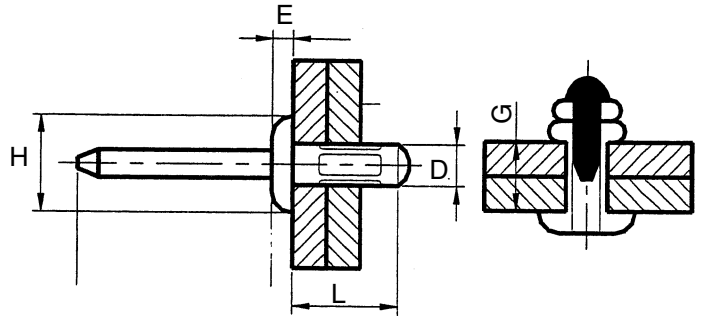

Extended grip range capacity reduces inventory (fewer sizes required).
 Use as a standard open-end rivet.
 No special tools required.
 Aluminum Rivet/Steel Mandrel.

Dome Head

RIVET NO.	"D"	"H"	"E"	"L"	GRIP RANGE
PR43ASPAA	0.121 min. 0.130 max.	0.240 min. 0.260 max.	0.040	0.315	.039-.187
PR44ASPAA				0.437	.046-.250
PR45ASPAA				0.453	.157-.312
PR46ASPAA				0.530	.187-.375
PR47ASPAA				0.595	.251-.441
PR54ASPAA	0.153 min. 0.161 max.	0.299 min. 0.327 max.	0.050	0.402	.047-.250
PR55ASPAA				0.484	.126-.315
PR58ASPAA				0.717	.376-.500
PR64ASPAA	0.183 min. 0.193 max.	0.394 min. 0.358 max.	0.060	0.425	.063-.250
PR66ASPAA				0.606	.126-.375
PR68ASPAA				0.717	.188-.500
PR612ASPAA				1.051	.438-.750

Large Flange Head

RIVET NO.	"D"	"H"	"E"	"L"	GRIP RANGE
PR43ASLAA	0.121 min. 0.130 max.	0.358 min. 0.390 max.	0.065	0.315	.039-.187
PR44ASLAA				0.437	.039-.250
PR45ASLAA				0.453	.157-.312
PR47ASLAA				0.595	.251-.441
PR54ASLAA	0.153 min. 0.161 max.	0.449 min. 0.484 max.	0.075	0.402	.047-.250
PR55ASLAA				0.484	.126-.315
PR58ASLAA				0.717	.376-.500
PR64ASLAA	0.183 min. 0.193 max.	0.602 min. 0.650 max.	0.091	0.425	.063-.250
PR66ASLAA				0.606	.126-.375
PR68ASLAA				0.717	.188-.500
PR612ASLAA				1.051	.438-.750

Countersunk Head

PART NO.	BODY DIAMETER	GRIP RANGE	M Max.	B Max.	D Max.	E Max.
PR44ASCAA	1/8	.093-.250	0.470	0.207	0.05	0.074
PR45ASCAA		.155-.312	0.530			
PR46ASCAA		.217-.375	0.600			
PR55ASCAA	5/32	.109-.312	0.550	0.247	0.052	0.09
PR56ASCAA		.174-.375	0.610			
PR65ASCAA	3/16	.125-.312	0.800	0.347	0.069	0.112
PR68ASCAA		.250-.500	0.610			

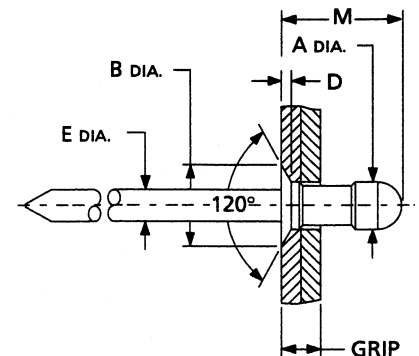

Available in steel upon request.



BLIND RIVETS: DOME PEEL RIVETS

ALUMINUM RIVET / STEEL MANDREL

Dome Peel Rivets split into four legs providing a large blind side bearing head for improved support in brittle, soft, or ductile materials. For more information or to place your order call us today.

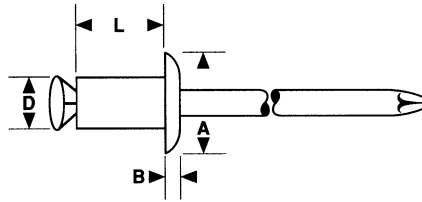

Head Style	Rivet Dia. Nom.	JAY-CEE Part Number	Grip Range (Inches)	Hole Sizes Drill No.	Dimensions (Inches)				Min. Strength (lbs)	
					D	B Max.	A	L Max.	Shear	Tensile
Dome	1/8"	PR42ASPP	.039 - .138	.142 #27	.122 - .138	.048	.228 - .256	.354	180	213
		PR43ASPP	.098 - .197					.433		
		PR44ASPP	.177 - .276					.512		
		PR46ASPP	.256 - .354					.590		
		PR47ASPP	.335 - .433					.669		
Dome	5/32"	PR52ASPP	.039 - .118	.173 #17	.151 - .169	.059	.275 - .315	.354	315	450
		PR53ASPP	.098 - .197					.433		
		PR54ASPP	.177 - .256					.512		
		PR55ASPP	.236 - .315					.590		
		PR56ASPP	.295 - .394					.669		
		PR58ASPP	.354 - .422					.748		
		PR510ASPP	.452 - .551					.827		
Dome	3/16"	PR62ASPP	.039 - .118	.204 #6	.183 - .201	.063	.335 - .374	.354	450	607
		PR63ASPP	.098 - .197					.433		
		PR64ASPP	.177 - .276					.512		
		PR65ASPP	.256 - .354					.590		
		PR66ASPP	.335 - .394					.669		
		PR68ASPP	.375 - .472					.748		
		PR610ASPP	.453 - .551					.827		
		PR612ASPP	.531 - .748					1.024		



TRIBEX BLIND RIVETS

Tribex Blind Rivets are ideal for applications involving brittle materials.

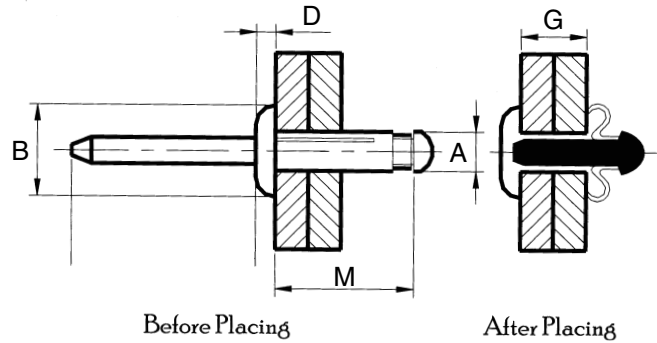

Series	Head Style	Material		Finish	
		Rivet	Mandrel	Rivet	Mandrel
AAPAB	Dome Head	Aluminum	Aluminum	Plain	Plain
AALAB	Large Flange	Aluminum	Aluminum	Plain	Plain

Nom. Rivet Diam.	Hole Size	E Max.	A Rivet Diam.	Dome Head		Large-Flange Head	
				B Nom. Head Diam.	D Max. Head Ht.	B Nom. Head Diam.	D Max. Head Ht.
5/32"	.165-.177	0.09	0.157	0.312	0.06	-	-
(4.0mm)	(4.20-4.50 mm)	(2.27 mm)	(4.19 mm)	(07.9 mm)	(1.53 mm)	-	-
3/16"	.197-.207	0.112	0.188	0.387	0.08	0.61	0.08
(4.8mm)	(5.00-5.25 mm)	(2.83 mm)	(5 mm)	(9.83 mm)	(2.04 mm)	(15.5 mm)	(2.04 mm)

Rivet Diam.	Grip Range	M Max.	AAPAB - Dome Head Aluminum Rivet Aluminum Mandrel	AALAB - Large-Flange Head Aluminum Rivet Aluminum Mandrel
5/32" (4.0mm)	.040-.118 (1.00-3.00 mm)	.630 (16 mm)	PR52AAPAB	-
	.040-.275 (1.00-7.50 mm)	.840 (21.2 mm)	PR54AAPAB	-
3/16" (4.8mm)	.040-.157 (1.00-4.00)	.720 (18.3 mm)	PR62.5AAPAB	PR62.5AALAB
	.040-.354 (1.00-9.00 mm)	.920 (23.3 mm)	PR66AAPAB	PR66AALAB
	.157-.472 (4.00-12.00 mm)	1.07 (27.1 mm)	PR68AAPAB	-

Typical Rivet Shear and Tensile Strength lbf. (N) TRIBEX

Rivet Diam.	AAPAB/AALAB Aluminum	
	Shear	Tensile
5/32" (4.0mm)	135 (600)	225 (1000)
3/16" (4.8mm)	175 (780)	240 (1070)



LOCKBOLTS AND COLLARS



Huck Magna Grip®



Huck Lock Bolt C6L®



Hucktainer®



Lockbolt Tooling

LOCKBOLTS

LockBolts consist of two parts: a pin, and a collar. The bolt is inserted into one side of the joint material and the collar is placed over the bolt from the other side of the joint material. Access to both sides of the joint is required. A Huck installation tool is used to swage the collar materials into the grooves of the bolt providing a permanent and vibration resistant fastening.

Key Benefits:

- Permanent, mechanically locked fastener
- Installation process automatically provides fastener values
- No torque or re-torque required
- Unlike conventional nuts and bolts, they will not work loose, even during extreme vibration
- Rapid installation with Quick and easy visual inspection
- Excellent gap closure capability
- Can be installed onto angled surfaces (5° maximum)
- Tamperproof

HOW LOCKBOLTS WORK

Clamp Force or Pre-Load: In the initial stages of the installation process, the tool engages and pulls on the pintail. The joint is pulled together before the conical shaped cavity of the nose assembly is forced down the collar. This progressively locks (swages) it into the grooves of the harder pin. The pin and swaged collar combine to form the installed fastener.

The squeezing action reduces the diameter of the collar, increasing its length. This in turn stretches the pin, generating a clamp force over the joint.

Shear strength of LockBolts vary according to the material strength and minimal diameter of the fastener. By increasing the diameter or the grade of material, the shear strength of the fastener can be increased.

The tensile strength of LockBolts is dependent on the shear resistance of the collar material and the number of grooves it fills

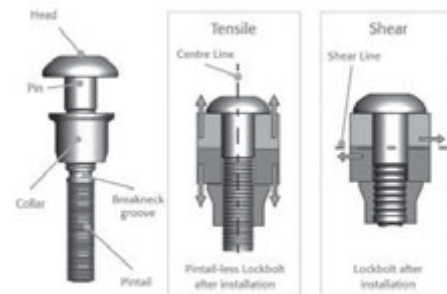

LockBolt Installation Sequence

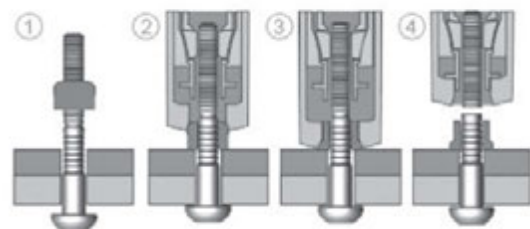

1. Pin placed into prepared hole - Collar placed over pin
2. Tool is placed over the fastener pintail and activated
 - Pin head pulled against material
 - Anvil pushes collar against joint
 - Initial clamp generated
3. Tool swages collar, increasing clamp
4. Pintail breaks, installation complete



RIVET NUTS: L-SERIES

The ribbed L Rivet Nut Series features a large flange head configuration with a ribbed body.

RIBBED BODY

The ribbed body provides increased resistance from spinning.

LARGE HEAD

Provides a large bearing surface which increases push-out performance.

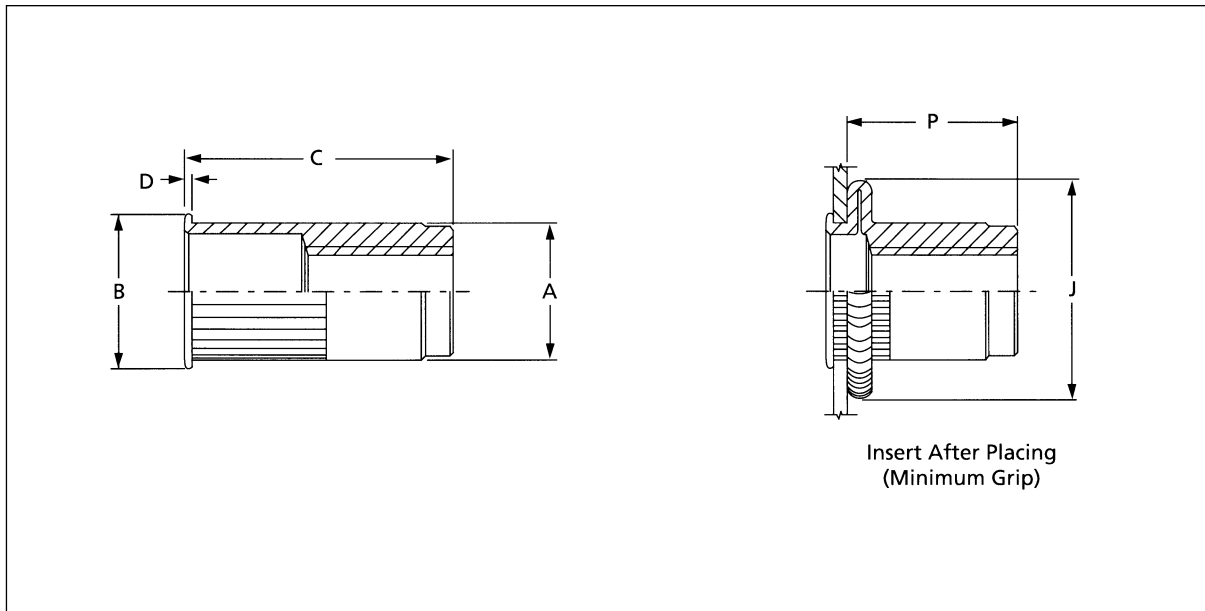



RIVET NUTS: L-SERIES

ALUMINUM - 5056 plain finish
 STEEL - C1008, yellow zinc (Bu)
 STAINLESS STEEL - 18-8

Thread Designation	Grip Range	Hole +.006 Dia. -.000	Steel Series	Aluminum Series	18-8 S/S Series	A Max.	B Nom.	C Max.	P Ref.	D Max.
#6-32 UNC	.020-.080	17/64 (.2656)	RN632080SLR	RN632080ALR	RN632080FLR	.265	.375	.460	.275	.032
#6-32 UNC	.080-.130	17/64 (.2656)	RN632130SLR	RN632130ALR	RN632130FLR	.265	.375	.510	.275	.032
#8-32 UNC	.020-.080	17/64 (.2656)	RN832080SLR	RN832080ALR	RN832080FLR	.265	.375	.460	.275	.032
#8-32 UNC	.080-.130	17/64 (.2656)	RN832130SLR	RN832130ALR	RN832130FLR	.265	.375	.510	.275	.032
#10-24 UNC	.020-.130	19/64 (.2969)	RN1024130SLR	RN1024130ALR	RN1024130FLR	.296	.400	.515	.300	.037
#10-24 UNC	.130-.225	19/64 (.2969)	RN1024225SLR	RN1024225ALR	RN1024225FLR	.296	.400	.625	.300	.037
#10-32 UNF	.020-.130	19/64 (.2969)	RN1032130SLR	RN1032130ALR	RN1032130FLR	.296	.400	.515	.300	.037
#10-32 UNF	.130-.225	19/64 (.2969)	RN1032225SLR	RN1032225ALR	RN1032225FLR	.296	.400	.625	.300	.037
1/4-20 UNC	.027-.165	25/64 (.3906)	RN2520165SLR	RN2520165ALR	RN2520165FLR	.390	.500	.620	.355	.037
1/4-20 UNC	.165-.260	25/64 (.3906)	RN2520260SLR	RN2520260ALR	RN2520260FLR	.390	.500	.720	.355	.037
1/4-28 UNF	.027-.165	25/64 (.3906)	RN2528165SLR	RN2528165ALR	RN2528165FLR	.390	.500	.620	.355	.037
1/4-28 UNF	.165-.260	25/64 (.3906)	RN2528260SLR	RN2528260ALR	RN2528260FLR	.390	.500	.720	.355	.037
5/16-18 UNC	.027-.150	17/32 (.5312)	RN5161815SLR	RN5161815ALR	RN5161815FLR	.530	.670	.735	.430	.042
5/16-18 UNC	.150-.312	17/32 (.5312)	RN5161831SLR	RN5161831ALR	RN5161831FLR	.530	.670	.850	.430	.042
5/16-24 UNF	.027-.150	17/32 (.5312)	RN5162415SLR	RN5162415ALR	RN5162415FLR	.530	.670	.735	.430	.042
5/16-24 UNF	.150-.312	17/32 (.5312)	RN5162431SLR	RN5162431ALR	RN5162431FLR	.530	.670	.850	.430	.042
3/8-16 UNC	.027-.150	17/32 (.5312)	RN3816150SLR	RN3816150ALR	RN3816150FLR	.530	.670	.735	.430	.042
3/8-16 UNC	.150-.312	17/32 (.5312)	RN3816312SLR	RN3816312ALR	RN3816312FLR	.530	.670	.850	.430	.042
3/8-24 UNF	.027-.150	17/32 (.5312)	RN3824150SLR	RN3824150ALR	RN3824150FLR	.530	.670	.735	.430	.042
3/8-24 UNF	.150-.312	17/32 (.5312)	RN3824312SLR	RN3824312ALR	RN3824312FLR	.530	.670	.850	.430	.042
1/2-13 UNC	.063-.200	11/16 (.6875)	RN5013200SLR	RN5013200ALR	RN5013200FLR	.685	.865	1.150	.850	.047
1/2-13 UNC	.200-.350	11/16 (.6875)	RN5013350SLR	RN5013350ALR	RN5013350FLR	.685	.865	1.300	.850	.047

ALUMINUM - 5056 plain finish
 STEEL - C1008, yellow zinc (Bu)
 STAINLESS STEEL - 18-8

Thread Designation	Grip Range	Hole +.152 Dia. -.000	Steel Series	Aluminum Series	18-8 S/S Series	A Max.	B Nom.	C Max.	P Ref.	D Max.
M4x0.7 ISO	.50-2.0	6.8	RN47020SLR	RN47020ALR	RN47020FLR	6.75	9.50	11.70	7.00	0.81
M4x0.7 ISO	2.00-3.30	6.8	RN47033SLR	RN47033ALR	RN47033FLR	6.75	9.50	13.00	7.00	0.81
M5x0.8 ISO	.50-3.3	7.6	RN58033SLR	RN58033ALR	RN58033FLR	7.55	10.10	13.10	7.60	0.94
M5x0.8 ISO	3.30-5.70	7.6	RN58057SLR	RN58057ALR	RN58057FLR	7.55	10.10	15.90	7.60	0.94
M6x1.0 ISO	.70-4.2	10.0	RN61042SLR	RN61042ALR	RN61042FLR	9.90	12.70	15.75	9.00	0.94
M6x1.0 ISO	4.2-6.6	10.0	RN61066SLR	RN61066ALR	RN61066FLR	9.90	12.70	18.30	9.00	0.94
M8x1.25 ISO	.70-3.8	13.5	RN812538SLR	RN812538ALR	RN812538FLR	13.45	17.00	18.65	18.80	1.02
M8x1.25 ISO	3.80-7.90	13.5	RN812579SLR	RN812579ALR	RN812579FLR	13.45	17.00	21.60	18.80	1.02
M10x1.5 ISO	.70-3.8	13.5	RN101538SLR	RN101538ALR	RN101538FLR	13.45	17.00	18.65	18.80	1.02
M10x1.5 ISO	3.80-7.90	13.5	RN101579SLR	RN101579ALR	RN101579FLR	13.45	17.00	21.60	18.80	1.02
M12x1.75 ISO	1.60-5.10	17.45	RN1217551SLR	RN1217551ALR	RN1217551FLR	17.4	21.97	29.21	21.59	1.19
M12x1.75 ISO	5.10-8.9	17.45	RN1217589SLR	RN1217589ALR	RN1217589FLR	17.4	21.97	33.02	21.59	1.19



RIVET NUTS: K-SERIES

The ribbed K Rivet Nut Series features a reduced head configuration with a ribbed body.

RIBBED BODY

The ribbed body provides increased resistance from spinning.

REDUCED HEAD

Provides near flush head with the surface.

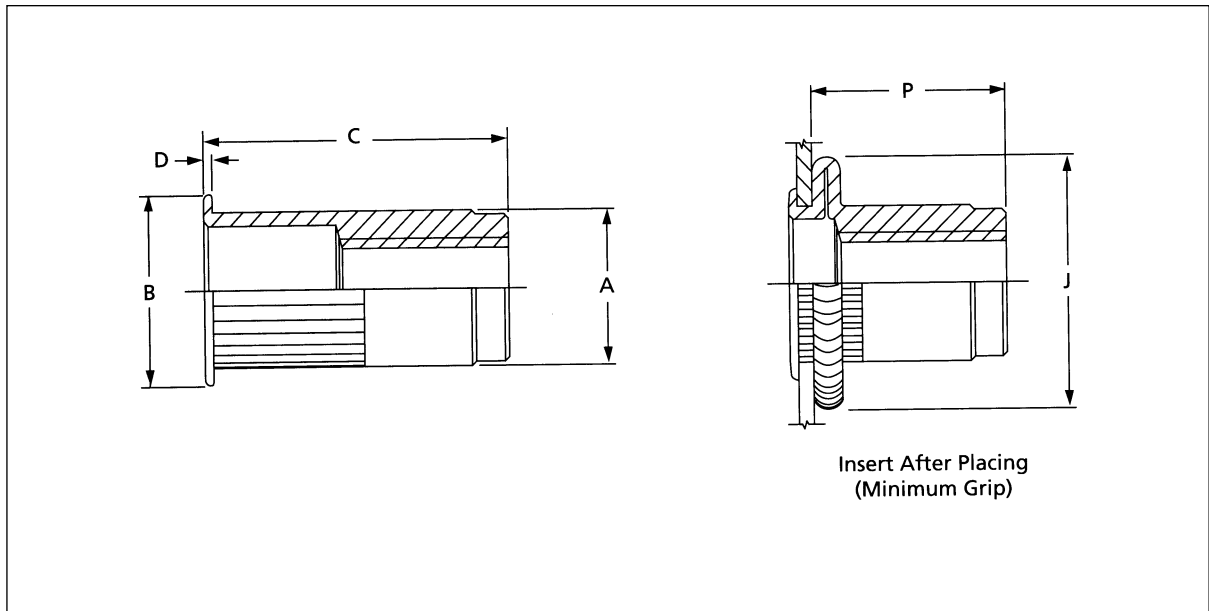



RIVET NUTS: K-SERIES

ALUMINUM - 5056 plain finish
 STEEL - C1008, yellow zinc (Bu)
 STAINLESS STEEL - 18-8

Thread Designation	Grip Range	Hole +.006 Dia. -.000	Steel Series	Aluminum Series	18-8 S/S Series	A Max.	B Nom.	C Max.	P Ref.	D Max.	J Max.
#6-32 UNC	.020-.080	17/64 (.2656)	RN632080SKR	RN632080AKR	RN632080FKR	.265	.310	.450	.305	.019	.390
#6-32 UNC	.080-.130	17/64 (.2656)	RN632130SKR	RN632130AKR	RN632130FKR	.265	.310	.500	.305	.019	.390
#8-32 UNC	.020-.080	17/64 (.2656)	RN832080SKR	RN832080AKR	RN832080FKR	.265	.310	.450	.305	.019	.390
#8-32 UNC	.080-.130	17/64 (.2656)	RN832130SKR	RN832130AKR	RN832130FKR	.265	.310	.500	.305	.019	.390
#10-24 UNC	.020-.130	19/64 (.2969)	RN1024130SKR	RN1024130AKR	RN1024130FKR	.296	.340	.505	.315	.020	.450
#10-24 UNC	.130-.225	19/64 (.2969)	RN1024225SKR	RN1024225AKR	RN1024225FKR	.296	.340	.615	.315	.020	.450
#10-32 UNF	.020-.130	19/64 (.2969)	RN1032130SKR	RN1032130AKR	RN1032130FKR	.296	.340	.505	.315	.020	.450
#10-32 UNF	.130-.225	19/64 (.2969)	RN1032225SKR	RN1032225AKR	RN1032225FKR	.296	.340	.615	.315	.020	.450
1/4-20 UNC	.027-.165	25/64 (.3906)	RN2520165SKR	RN2520165AKR	RN2520165FKR	.390	.455	.610	.380	.021	.550
1/4-20 UNC	.165-.260	25/64 (.3906)	RN2520260SKR	RN2520260AKR	RN2520260FKR	.390	.455	.710	.380	.021	.550
1/4-28 UNF	.027-.165	25/64 (.3906)	RN2528165SKR	RN2528165AKR	RN2528165FKR	.390	.455	.610	.380	.021	.550
1/4-28 UNF	.165-.260	25/64 (.3906)	RN2528260SKR	RN2528260AKR	RN2528260FKR	.390	.455	.710	.380	.021	.550
5/16-18 UNC	.027-.150	17/32 (.5312)	RN5161815SKR	RN5161815AKR	RN5161815FKR	.530	.595	.720	.470	.023	.740
5/16-18 UNC	.150-.312	17/32 (.5312)	RN5161831SKR	RN5161831AKR	RN5161831FKR	.530	.595	.835	.470	.023	.740
5/16-24 UNF	.027-.150	17/32 (.5312)	RN5162415SKR	RN5162415AKR	RN5162415FKR	.530	.595	.720	.470	.023	.740
5/16-24 UNF	.150-.312	17/32 (.5312)	RN5162431SKR	RN5162431AKR	RN5162431FKR	.530	.595	.835	.470	.023	.740
3/8-16 UNC	.027-.150	17/32 (.5312)	RN3816150SKR	RN3816150AKR	RN3816150FKR	.530	.595	.720	.470	.023	.740
3/8-16 UNC	.150-.312	17/32 (.5312)	RN3816312SKR	RN3816312AKR	RN3816312FKR	.530	.595	.835	.470	.023	.740
3/8-24 UNF	.027-.150	17/32 (.5312)	RN3824150SKR	RN3824150AKR	RN3824150FKR	.530	.595	.720	.470	.023	.740
3/8-24 UNF	.150-.312	17/32 (.5312)	RN3824312SKR	RN3824312AKR	RN3824312FKR	.530	.595	.835	.470	.023	.740

ALUMINUM - 5056 plain finish
 STEEL - C1008, yellow zinc (Bu)
 STAINLESS STEEL - 18-8

Thread Designation	Grip Range	Hole +.152 Dia. -.000	Steel Series	Aluminum Series	18-8 S/S Series	A Max.	B Nom.	C Max.	P Ref.	D Max.	J Max.
M4x0.7 6H	.50-2.0	6.8	RN47020SKR	RN47020AKR	RN47020FKR	6.75	7.87	11.45	7.75	0.48	9.91
M4x0.7 6H	2.00-3.30	6.8	RN47033SKR	RN47033AKR	RN47033FKR	6.75	7.87	12.70	7.75	0.48	9.91
M5x0.8 6H	.50-3.3	7.6	RN58033SKR	RN58033AKR	RN58033FKR	7.75	8.64	12.85	8.00	0.51	11.43
M5x0.8 6H	3.30-5.70	7.6	RN58057SKR	RN58057AKR	RN58057FKR	7.75	8.64	15.65	8.00	0.51	11.43
M6x1.0 6H	.70-4.2	10.0	RN61042SKR	RN61042AKR	RN61042FKR	9.90	11.56	15.50	9.65	0.53	13.97
M6x1.0 6H	4.20-6.60	10.0	RN61066SKR	RN61066AKR	RN61066FKR	9.90	11.56	18.05	9.65	0.53	13.97
M8x1.25 6H	.70-3.8	13.5	RN812538SKR	RN812538AKR	RN812538FKR	13.45	15.11	18.30	11.94	0.58	18.80
M8x1.25 6H	3.80-7.90	13.5	RN812579SKR	RN812579AKR	RN812579FKR	13.45	15.11	21.20	11.94	0.58	18.80
M10x1.5 6H	.70-3.8	13.5	RN101538SKR	RN101538AKR	RN101538FKR	13.45	15.11	18.30	11.94	0.58	18.80
M10x1.5 6H	3.80-7.90	13.5	RN101579SKR	RN101579AKR	RN101579FKR	13.45	15.11	21.20	11.94	0.58	18.80



HEX RIVET NUTS

The Hex rivet nut offers superior spin out resistance in hex holes. The part is **supplied in steel** but may be purchased in other materials though minimums may apply.



OPEN END TYPE

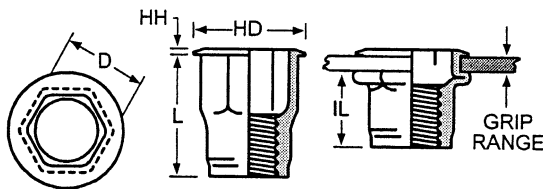

Thread Specifications: Unified 2B/21 per ASME B.1.1
Metric 6H/21 per ASME B.1.13M

HOLE DETAIL

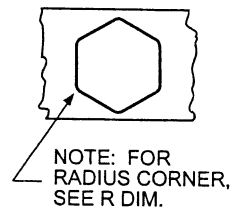

Part No.	Thread Size	Grip Range Out	Grip Call +.004-.000	Hole Size (Across Flats) +.025*	HD ±.010 +.003	HH ±.015	L Max.	D Max.	IL ±.015	R
RN632080SLX	6-32 UNC	.020-.080	080	.250	.375	.027	.385	.249	.295	.015
RN632130SLX	6-32 UNC	.080-.130	130	.250	.375	.027	.435	.249	.295	.015
RN832080SLX	8-32 UNC	.020-.080	080	.250	.375	.027	.385	.249	.295	.015
RN832130SLX	8-32 UNC	.080-.130	130	.250	.375	.027	.435	.249	.295	.015
RN1024130SLX	10-24 UNC	.020-.130	130	.281	.390	.027	.435	.280	.275	.020
RN1024225SLX	10-24 UNC	.130-.225	225	.281	.390	.027	.535	.280	.275	.020
RN1032130SLX	10-32 UNF	.020-.130	130	.281	.390	.027	.435	.280	.275	.020
RN1032225SLX	10-32 UNF	.130-.225	225	.281	.390	.027	.535	.280	.275	.020
RN2520165SLX	1/4-20 UNC	.027-.165	165	.375	.510	.030	.585	.374	.400	.040
RN2520260SLX	1/4-20 UNC	.165-.260	260	.375	.510	.030	.685	.374	.400	.040
RN2528165SLX	1/4-28 UNF	.027-.165	165	.375	.510*	.030	.685	.374	.400	.040
RN2528260SLX	1/4-28 UNF	.165-.260	260	.375	.510*	.030	.685	.374	.400	.040
RN5161815SLX	5/16-18 UNC	.027-.150	150	.500	.655*	.035	.685	.499	.530	.040
RN5161831SLX	5/16-18 UNC	.150-.312	312	.500	.655*	.035	.845	.499	.515	.040
RN3816150SLX	3/8-16 UNC	.027-150	150	.500	.655*	.035	.685	.499	.530	.040
RN3816312SLX	3/8-16 UNC	.150-312	312	.500	.655*	.035	.845	.499	.515	.040

Part No.	Thread Size	Grip Range Out	Grip Call +.010-0.00	Hole Size (Across Flats) +.064*	HD ±.025 ±.008	HH ±.038	L Max.	D Max.	IL ±.038	R
RN47020SLX	M4 x 0.7 ISO	0.50-2.00	2.0	6.35	9.53	0.68	9.78	6.35	7.49	.38
RN47033SLX	M4 x 0.7 ISO	2.00-3.30	3.3	6.35	9.53	0.68	11.05	6.35	7.49	.38
RN58033SLX	M5 x 0.8 ISO	0.50-3.30	3.3	7.14	9.91	0.68	11.05	7.10	6.99	.50
RN58057SLX	M5 x 0.8 ISO	3.30-5.70	5.7	7.14	9.91	0.68	13.59	7.10	6.99	.50
RN61042SLX	M6 x 1.0 ISO	0.70-4.20	4.2	9.53	12.96	0.76	14.86	9.50	10.16	1.0
RN61066SLX	M6 x 1.0 ISO	4.20-6.60	6.6	9.53	12.96	0.76	17.40	9.50	10.16	1.0
RN812538SLX	M8 x 1.25 ISO	0.70-3.8	3.8	12.70	16.64*	0.89	17.40	12.70	13.46	1.0
RN812579SLX	M8 x 1.25 ISO	3.8-7.90	7.9	12.70	16.64*	0.89	21.46	12.70	13.08	1.0
RN101538SLX	M10 x 1.5 ISO	0.70-3.8	3.8	12.70	16.64*	0.89	17.40	12.70	13.46	1.0
RN101579SLX	M10 x 1.5 ISO	3.8-7.90	7.9	12.70	16.64*	0.89	21.46	12.70	13.08	1.0



RIVET NUTS AND THREADED INSERTS

Flat Head Rivet Nuts

The Flat Head rivet nut is designed for applications needing superior push out loads and features a large bearing surface.

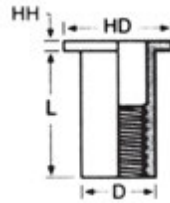

Steel Zinc Plated Rivet Nut (Flat Head) Specification

PART NUMBER STEEL	PART NUMBER ALUMINUM	THREAD SIZE	GRIP RANGE	D BODY DIA +.000/- .004	LENGTH L +/- .015	HD HEAD DIA +/- .015	HOLE SIZE
RN632075SF	RN632075AF	6-32 UNC	.010-0.075	0.189	0.438	0.325	.189
RV632120SF	RV632120AF	6-32 UNC	.075-0.120	0.189	0.500	0.325	.189
RN632160SF	RN632160AF	6-32 UNC	.120-0.160	0.189	0.500	0.325	.189
RN832075SF	RN832075AF	8-32 UNC	.010-0.075	0.221	0.438	0.357	.221
RN832120SF	RN832120AF	8-32 UNC	.075-0.120	0.221	0.500	0.357	.221
RN832160SF	RN832160AF	8-32 UNC	.120-0.160	0.221	0.500	0.357	.221
RN1024080SF	RN1024080AF	10-24 UNC	.010-0.080	0.250	0.531	0.406	.250
RN1024130SF	RN1024130AF	10-24 UNC	.080-0.130	0.250	0.594	0.406	.250
RN1024180SF	RN1024180AF	10-24 UNC	.130-0.180	0.250	0.641	0.406	.250
RN1032080SF	RN1032080AF	10-32 UNF	.010-0.080	0.250	0.531	0.406	.250
RN1032130SF	RN1032130AF	10-32 UNF	.080-0.130	0.250	0.594	0.406	.250
RN1032180SF	RN1032180AF	10-32 UNF	.130-0.180	0.250	0.641	0.406	.250
RN2520080SF	RN2520080AF	1/4-20 UNC	.010-0.080	0.332	0.625	0.475	.332
RN2520140SF	RN2520140AF	1/4-20 UNC	.080-0.140	0.332	0.687	0.475	.332
RN2520200SF	RN2520200AF	1/4-20 UNC	.140-0.200	0.332	0.750	0.475	.332
RN51618125SF	RN51618125AF	5/16-18 UNC	.030-0.125	0.413	0.750	0.665	.413
RN51618200SF	RN51618200AF	5/16-18 UNC	.125-0.200	0.413	0.875	0.665	.413
RN51618275SF	RN51618275AF	5/16-18 UNC	.200-0.275	0.413	0.937	0.665	.413
RN3816115SF	RN3816115AF	3/8-16 UNC	.030-0.115	0.490	0.844	0.781	.490
RN3816200SF	RN3816200AF	3/8-16 UNC	.115-0.125	0.490	0.938	0.781	.490
RN3816285SF	RN3816285AF	3/8-16 UNC	.125-0.200	0.490	1.031	0.781	.490

Specials available in stainless steel. Minimums may apply.

Threaded Inserts

Thread-Serts are versatile threaded fasteners that can be used in a variety of applications. Use Thread-Serts in any thickness of metal or rigid material of at least 3/32" (.0937). Eliminate the need for tapping, welding and brazing. Thread-Sert design consists of an upper sleeve and a base which both have internal and external threads. During installation the base is drawn upwards inside the upper sleeve forcing a 360° contact between the sleeve and application material. No special preparation is needed; a drilled or punched hole is all that is required. Because of its unique setting ability, Thread-Serts can be used in almost any thickness of material. Installation is made easy with a variety of tools and kits.

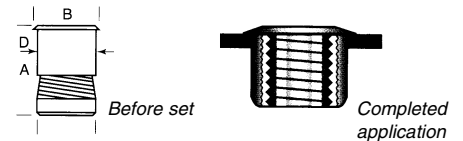

PART NUMBER ALUMINUM	PART NUMBER STEEL	THREAD SIZE	Material Thickness .0937-.1562		Material Thickness .0937-infinity		A* Body Length +/- .005"	B Head Dia. +/- .005"	D* Body Dia. +/- .002"
			HOLE SIZE	DRILL SIZE	HOLE SIZE	DRILL SIZE			
RN632ATS	RN632STS	6-32	.221	#2	.234	A	.375	.250	.215
RN832ATS	RN832STS	8-32	.250	1/4"	.261	G	.375	.282	.246
RN1024ATS	RN1024STS	10-24	.281	9/32"	.290	L	.375	.314	.277
RN1032ATS	RN1032STS	10-32	.281	9/32"	.290	L	.375	.314	.277
RN2520ATS	RN2520STS	1/4-20	.391	25/64"	.391	25/64"	.510	.408	.372
RN51618ATS	RN51618STS	5/16-18	.500	1/2"	.516	33/64"	.615	.537	.496
RN3816ATS	RN3816STS	3/8-16	.562	9/16"	.578	37/64"	.740	.600	.559



COUNTERSUNK RIVET NUTS

Available in Steel-Zinc Plated or Aluminum

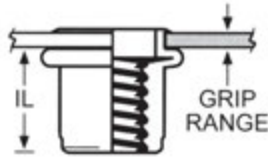
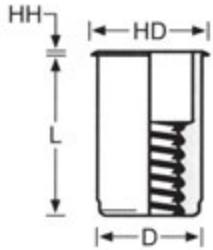

Thread Specifications: Unified 2B/21 per ASME B1.1
Metric 6H/21 per ASME B1.13M



PART NUMBER STEEL	PART NUMBER ALUMINUM	P/N	GRIP RANGE	D BODY DIA MAX	L LENGTH +/- .015	HD HEAD DIA +/- .010
RN632080SC	RN632080AC	6-32 UNC	.020-0.080	0.249	0.385	0.295
RN832080SC	RN832080AC	8-32UNC	.020-0.080	0.249	0.385	0.295
RN1024130SC	RN1024130AC	10-24 UNC	.020-0.130	0.280	0.440	0.320
RN1032130SC	RN1032130AC	10-32 UNF	.020-0.130	0.280	0.440	0.320
RN2520165SC	RN2520165AC	1/4-20 UNC	.030-0.165	0.374	0.580	0.425
RN51618200SC	RN51618200AC	5/16-18 UNC	.030-.200	0.499	0.690	0.560
RN3816200SC	RN3816200AC	3/8-16 UNC	.030-.200	0.499	0.690	0.560

PART NUMBER STEEL	PART NUMBER ALUMINUM	P/N	GRIP RANGE	D BODY DIA MAX	L LENGTH +/- .38	HD HEAD DIA +/- .25
RN47020SC	RN47020AC	M4 X 0.7 ISO	.50-2.0	6.32	9.78	7.49
RN58033SC	RN58033AC	M5 X 0.8 ISO	.50-3.3	7.11	11.18	8.13
RN61042SC	RN61042AC	M6 X 1.0 ISO	.76-4.2	9.50	14.73	10.80
RN812551SC	RN812551AC	M8 X 1.25 ISO	1.02-5.1	12.67	17.53	14.22
RN101551SC	RN101551AC	M10 X 1.5 ISO	1.02-5.1	12.67	17.53	14.22

Specials available in stainless steel. Minimums may apply.



JACK NUTS

Jack Nuts are used for light duty, thin, or brittle material. They accommodate slightly oversized holes with a large back side footprint similar to a wall anchor. Jack Nuts utilize a dedicated manual tool for proper installation.

Our jack nut installation tool is designed to effortlessly set jack nuts in sizes ranging from 6-32 – 1/4-20”, and M4 – M6. It works by threading the bolt to the jacknut, then dropping the component in the slot of the tool, inserting it into the pre-drilled hole, and squeezing until set. Pressing the release lever, then tightening completes the installation.

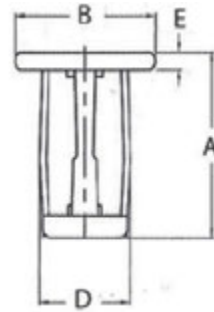

Thread Size	Grip Range	PART NUMBER	A	B	E	D
INCHES						
6-32	.000-.197	JN632197S	.670	0.472	0.063	0.315
6-32	.197-.394	JN632394S	.866	0.472	0.063	0.315
10-24	.000-.197	JN1024197S	.709	0.547	0.063	0.394
10-24	.197-.394	JN1024394S	.906	0.547	0.063	0.394
1/4-20	.000-.197	JN2520197S	.709	0.63	0.063	0.472
1/4-20	.197-.394	JN2520394S	.906	0.63	0.063	0.472
METRIC						
M4X0.7	.0-5.0MM	JN47050S	17.0	12.00	1.60	8.00
M4X.07	5.0-10.0MM	JN47010S	22.0	12.00	1.60	8.00
M5X0.8	.0-5.0MM	JN58050S	18.0	13.90	1.60	10.00
M5X0.8	5.0-10.0MM	JN58010S	23.0	13.90	1.60	10.00
M6X1.0	.0-5.0MM	JN61050S	18.0	16.00	1.60	12.00
M6X1.0	5.0-10.0MM	JN61010S	23.0	16.00	1.60	12.00



RIVNUT® PN - PLUSNUT® PRE-BULBED

The Rivnut® PN – Plusnut® Pre-Bulbed has been designed to be installed using torque controlled hand or power tools. A simple torque hand tool can be packaged with this fastener for customer installation. Use of the C 350 power tool can install this fastener in variable thickness plastic materials such as those produced by rotational or blow molding. A grip ID mark is included on the head of the fastener for grip range identification.

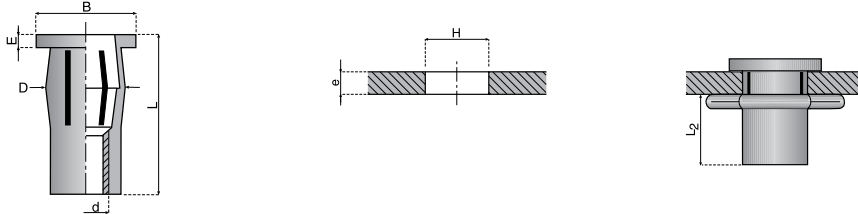

All Dimensions Shown In Inches

Thread Size	Grip Range	H		D	E	B	L	L2	Product Code
		Min.	Max.						
10-32	0.020-0.175	0.312	0.317	0.310	0.038	0.500	0.80	0.425	RN1032175PNB
10-32	0.175-0.320	0.312	0.317	0.310	0.038	0.500	0.94	0.425	RN1032320PNB
1/4-20	0.020-0.280	0.386	0.391	0.384	0.058	0.625	1.03	0.505	RN2520280PNB
1/4-20	0.280-0.500	0.386	0.391	0.384	0.058	0.625	1.26	0.505	RN2520500PNB
5/16-18	0.020-0.280	0.484	0.489	0.482	0.062	0.750	1.18	0.570	RN5161828PNB
5/16-18	0.280-0.500	0.484	0.489	0.482	0.062	0.750	1.41	0.570	RN5161850PNB
3/8-16	0.020-0.280	0.562	0.569	0.560	0.088	0.875	1.27	0.605	RN3816280PNB
3/8-16	0.280-0.500	0.562	0.569	0.560	0.088	0.875	1.49	0.605	RN3816500PNB

All Dimensions Shown In Millimeters

Thread Size	Grip Range	H		D	E	B	L	L2	Product Code
		Min.	Max.						
M6x1.0	0.50-7.10	9.80	9.93	9.76	1.50	15.9	26.2	12.8	RN61071PNB
M6x1.0	7.10-12.70	9.80	9.93	9.76	1.50	15.9	32.0	12.8	RN610127PNB
M8x1.25	0.50-7.10	12.29	12.42	12.25	1.57	19.0	30.0	14.5	RN812571PNB
M8x1.25	7.10-12.70	12.29	12.42	12.25	1.57	19.0	35.8	14.5	RN8125127PNB
M10x1.50	0.50-7.10	14.27	14.15	14.23	2.24	22.2	32.3	15.4	RN101571PNB
M10x1.50	7.10-12.70	14.27	14.15	14.23	2.24	22.2	37.8	15.4	RN1015127PNB



RIVNUT® PN - PLUSNUT®

The Rivnut® PN – Plusnut® has been designed to provide the ultimate pull out strength in thin sheet metals and plastic. Its slotted body splits into four legs providing a wide load-bearing surface on the backside of the parent material. The Rivnut® PN – Plusnut® also features the widest grip range of any blind threaded nut. A grip ID mark is included on the head of the fastener for grip range identification.

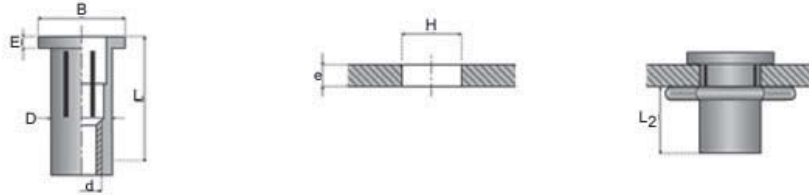

Class 2B or Metric Class 6H threads
 Steel C1010-1008
 Cadmium plating per QQ-P-416

All Dimensions Shown In Inches

d	e	H		D	E	B	L	L2	Product Code
		Min.	Max.						
Thread Size	Grip Range	Hole Size		Body Diameter Max.	Head Height Ref.	Head Diameter Ref.	Overall Length Ref.	Installed Length Ref.	
6-32	0.020-0.150	0.209	0.214	0.208	0.032	0.438	0.688	0.335	RN632150PN
6-32	0.150-0.270	0.209	0.214	0.208	0.032	0.438	0.797	0.335	RN632270PN
8-32	0.020-0.150	0.242	0.247	0.241	0.038	0.438	0.694	0.340	RN832150PN
8-32	0.150-0.270	0.242	0.247	0.241	0.038	0.438	0.819	0.340	RN832270PN
10-32	0.020-0.175	0.273	0.278	0.272	0.038	0.500	0.819	0.425	RN1032175PN
10-32	0.175-0.320	0.273	0.278	0.272	0.038	0.500	0.959	0.425	RN1032320PN
1/4-20	0.020-0.280	0.347	0.352	0.346	0.058	0.625	1.058	0.505	RN2520280PN
1/4-20	0.280-0.500	0.347	0.352	0.346	0.058	0.625	1.292	0.505	RN2520500PN
5/16-18	0.020-0.280	0.438	0.443	0.437	0.062	0.750	1.203	0.570	RN5161828PN
5/16-18	0.280-0.500	0.438	0.443	0.437	0.062	0.750	1.437	0.570	RN5161850PN
3/8-16	0.020-0.280	0.515	0.522	0.514	0.088	0.875	1.306	0.605	RN3816280PN
3/8-16	0.280-0.500	0.515	0.522	0.514	0.088	0.875	1.525	0.605	RN3816500PN

All Dimensions Shown In Millimeters

d	e	H		D	E	B	L	L2	Product Code
		Min.	Max.						
Thread Size	Grip Range	Hole Size		Body Diameter Max.	Head Height Ref.	Head Diameter Ref.	Overall Length Ref.	Installed Length Ref.	
M4x0.7	0.50-3.80	6.13	6.25	6.12	0.96	11.1	17.6	8.6	RN47038PN
M4x0.7	3.80-6.85	6.13	6.25	6.12	0.96	11.1	20.8	8.6	RN47068PN
M5x0.8	0.50-4.45	7.48	7.62	7.47	0.96	12.7	22.0	9.9	RN58045PN
M5x0.8	4.45-8.10	7.48	7.62	7.47	0.96	12.7	24.8	9.9	RN58081PN
M6x1.0	0.50-7.10	8.80	8.93	8.79	1.50	15.9	26.9	12.8	RN61071PN
M6x1.0	7.10-12.70	8.80	8.93	8.79	1.50	15.9	32.8	12.8	RN610127PN
M8x1.25	0.50-7.10	11.11	11.50	11.10	1.57	19.0	30.5	14.5	RN812571PN
M8x1.25	7.10-12.70	11.11	11.50	11.10	1.57	19.0	36.5	14.5	RN8125127PN
M10x1.50	0.50-7.10	13.07	13.26	13.06	2.24	22.2	33.2	15.8	RN101571PN
M10x1.50	7.10-12.70	13.07	13.26	13.06	2.24	22.2	38.7	15.8	RN1015127PN



THREAD REPAIR KITS - UNIQUE/SPECIAL THREAD SIZE KITS



Features

- Create stronger and more efficient threads.
- Simple and easy to use.
- Designed for use in material such as alloys, steel, magnesium, plastic etc.
- Simplifies changeover from different thread forms
- Meets all current Military and Aviation Specifications
- Interchangeable with other brands of helically wound inserts.
- Wide temperature range of up to 800°F (430°C)
- Recoil is ISO 9001 registered.

Each kit contains a tool and inserts (helicals).

BSF - 30000+		
Size	Part No.	Inserts/Kit
3/16-32	RC-30030	10
1/4-26	RC-30048	10
5/16-22	RC-30058	10
3/8-20	RC-30068	10
7/16-18	RC-30070	10
1/2-16	RC-30080	5
9/16-16	RC-30090	5
5/8-14	RC-30100	5
3/4-12	RC-30120	5
7/8-11	RC-30140	5
1-10	RC-30160	5
1 1/4-9	RC-30200	5

BA - 30500+		
Size	Part No.	Inserts/Kit
0 BA	RC-30500	10
2 BA	RC-30520	10
4 BA	RC-30540	10
6 BA	RC-30560	10

BSP - 31000+		
Size	Part No.	Inserts/Kit
1/8-28	RC-31028	10
1/4-19	RC-31048	10
3/8-19	RC-31068	5
1/2-14	RC-31080	5
5/8-14	RC-31100	5
3/4-14	RC-31120	5
1 - 11	RC-31160	5

BSW - 32000+		
Size	Part No.	Inserts/Kit
1/8-40	RC-32020	10
3/16-24	RC-32030	10
1/4-20	RC-32040	10
5/16-18	RC-32058	10
3/8-16	RC-32060	10
7/16-14	RC-32070	5
1/2-12	RC-32080	5
9/16-12	RC-32090	5
5/8-11	RC-32100	5
3/4-10	RC-32120	5
7/8-9	RC-32140	5
1 - 8	RC-32160	5
1 1/8-7	RC-32180	5
1 1/4-7	RC-32200	5
1 3/8-6	RC-32220	5
1 1/2-6	RC-32240	4

NPT - 36000+		
Size	Part No.	Inserts/Kit
1/8-27	RC-36028	10
1/4-18	RC-36048	10
3/8-18	RC-36060	10
1/2-14	RC-36080	5
3/4-14	RC-36120	5
1 - 11 1/2	RC-36160	5

BSC - 36500+		
Size	Part No.	Inserts/Kit
5/16-26	RC-36508	10
3/8-26	RC-36608	10
7/16-26	RC-36700	5
1/2-26	RC-36800	5

8 TPI UN - 26180+		
Size	Part No.	Inserts/Kit
1 1/8-8	RC-36180	5
1 1/4-8	RC-36200	5
1 3/8-8	RC-36220	4
1 1/2-8	RC-36240	4
1 5/8-8	RC-36260	4
1 3/4-8	RC-36280	4
1 7/8-8	RC-36300	4
2-8	RC-36320	4

PLUG-SAVER (for taper seat or gasket port)	
Part No.	Description
RC-98141	Complete Repair Kit
RC-98142	Short Reach (3/8") Insert
RC-98143	Medium Reach (1/2") Insert
RC-98144	Long Reach (3/4") Inserts
RC-98145	Pilot Tap
RC-98146	Expanding Tool

SPECIAL SIZES		
Size	Part No.	Inserts/Kit
UNEF		
1/4-32	RC-34040-32	10
9/16-20	RC-34096-20	10
HARLEY		
1/4-24	RC-34048-24	10
7/16-16	RC-34078-16	10
CARBURETOR		
7/8-20	RC-34140-20	5
1-20	RC-34160-20	5
CUMMINS-HEAD BOLT		
11/16-16	RC-34118-16	6



THREAD REPAIR KITS - INDIVIDUAL THREAD SIZE KITS



Features

- Create stronger and more efficient threads.
- Simple and easy to use.
- Designed for use in material such as alloys, steel, magnesium, plastic etc.
- Simplifies changeover from different thread forms
- Meets all current Military and Aviation Specifications
- Interchangeable with other brands of helically wound inserts.
- Wide temperature range of up to 800°F (430°C)
- Recoil is ISO 9001 registered.

Each kit contains a tool and inserts (helicals).

UNC - 33000+		
Size	Part No.	Inserts/Kit
#2-56	RC-33528	10
#3-48	RC-33530	10
#4-40	RC-33548	10
#5-40	RC-33550	10
#6-32	RC-33568	10
#8-32	RC-33588	10
#10-24	RC-33608	10
#12-24	RC-33628	10
1/4-20	RC-33048	10
5/16-18	RC-33058	10
3/8-16	RC-33068	10
7/16-14	RC-33078	5
1/2-13	RC-33088	5
9/16-12	RC-33098	5
5/8-11	RC-33108	5
11/16-11	RC-33110	5
3/4-10	RC-33128	5
7/8-9	RC-33140	5
1 - 8	RC-33160	5
1 1/8-7	RC-33180	5
1 1/4-7	RC-33200	5
1 3/8-6	RC-33220	5
1 1/2-6	RC-33240	4

UNF - 34000+		
Size	Part No.	Inserts/Kit
#3-56	RC-34530	10
#4-48	RC-34540	10
#6-40	RC-34560	10
#8-36	RC-34580	10
#10-32	RC-34608	10
#12-28	RC-34628	10
1/4-28	RC-34048	10
5/16-24	RC-34058	10
3/8-24	RC-34068	10
7/16-20	RC-34078	5
1/2-20	RC-34088	5
9/16-18	RC-34090	5
5/8-18	RC-34100	5
3/4-16	RC-34120	5
7/8-14	RC-34140	5
1 - 12	RC-34160	5
1 - 14	RC-34160-14	5
1 1/8-12	RC-34180	5
1 1/4-12	RC-34200	5
1 3/8-12	RC-34220	3
1 1/2-12	RC-34240	3

METRIC COARSE - 35000+		
Size	Part No.	Inserts/Kit
M2-.4	RC-35028	10
M2.2-.45	RC-35010	10
M2.5-.45	RC-35258	10
M3-.5	RC-35038	10
M3.5-.6	RC-35350	10
M4-.7	RC-35048	10
M5-.8	RC-35058	10
M6-1	RC-35068	10
M7-1	RC-35078	10
M8-1.25	RC-35088	10
M9-1.25	RC-35098	10
M10-1.5	RC-35108	10
M11-1.5	RC-35118	5
M12-1.75	RC-35128	5
M14-2	RC-35140	5
M16-2	RC-35168	5
M18-2.5	RC-35180	5
M20-2.5	RC-35208	5
M22-2.5	RC-35220	5
M24-3	RC-35240	5
M27-3	RC-35270	5
M30-3.5	RC-35300	5
M30-3	RC-35300-3	5
M36-4	RC-35360	4
M39-4	RC-35390	5
M42-4.5	RC-35420	5
M42-4	RC-35420-4	4



THREAD REPAIR KITS - INDIVIDUAL THREAD SIZE KITS



Features

- Create stronger and more efficient threads.
- Simple and easy to use.
- Designed for use in material such as alloys, steel, magnesium, plastic etc.
- Simplifies changeover from different thread forms
- Meets all current Military and Aviation Specifications
- Interchangeable with other brands of helically wound inserts.
- Wide temperature range of up to 800°F (430°C)
- Recoil is ISO 9001 registered.

Each kit contains a tool and inserts (helicals).

METRIC MEDIUM - 37000+		
Size	Part No.	Inserts/Kit
M8-1	RC-37088	10
M9-1	RC-37098	10
M10-1.25	RC-37108	10
M11-1.25	RC-37118	5
M12-1.5	RC-37128	5
M14-1.5	RC-37148	5
M16-1.5	RC-37160	5
M18-2	RC-37180	5
M20-2	RC-37200	5
M22-2	RC-37220	5
M24-2	RC-37240	5
M27-2	RC-37270	5
M30-2	RC-37300	5
M36-3	RC-37360	4
M39-3	RC-37390	5
M42-3	RC-37420	4

METRIC X FINE - 38000+		
Size	Part No.	Inserts/Kit
M10-1	RC-38108	10
M11-1	RC-38118	5
M12-1.25	RC-38128	5
M14-1.25*	RC-38141	5
M18-1.5*	RC-38188-1	5
M20-1.5	RC-38208	5
M22-1.5	RC-38220	5
M24-1.5	RC-38240	5
M26-1.5	RC-38260	5
M27-1.5	RC-38270	5
M30-1.5	RC-38300	5
M36-1.5	RC-38360	4
M39-2	RC-38390	5
M42-2	RC-38420	4
* Different to spark plug - inter tap		

SPARK PLUG - 38000+		
Size	Part No.	Inserts/Kit
M10-1	RC-38108-2	10
M12-1.25	RC-38120	10
M14-1.25*	RC-38140	10
M14-1.25	RC-38142	5
M18-1.5	RC-38188	5
* INCL. EXTRACTING TOOL IN LARGE TIN		



EYELETS

EYELETS

Our GS Eyelets consists of various eyelets where the length and outside barrel diameters are graduated by 1/32". This grouping will meet the requirements of most general purpose eyeleting applications. Eyelets are most commonly requested in brass. Eyelets can also be made from steel, stainless steel, aluminum, and copper.

Eyelet Options

In addition to our Rolled Flange GS® Eyelets, GS® Eyelets can also be made with a flat flange, or with a closed end.

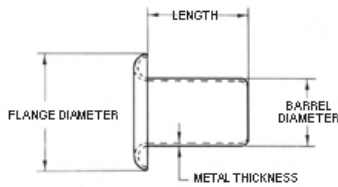

Length Under Flange	1/16	3/32	1/8	5/32	3/16	7/32	1/4	9/32	5/16	11/32	3/8	13/32	7/16
Barrel Dia. 0.059													
Flange Diameter 0.105	GS2-2B	GS2-3B	GS2-4B	GS2-5B	GS2-6B	GS2-7B	—	—	—	—	—	—	—
*Metal Thickness 0.007													
Barrel Diameter 0.089													
Flange Diameter 0.150	—	GS3-3B	GS3-4B	GS3-5B	GS3-6B	GS3-7B	GS3-8B	GS3-9B	GS3-10B	GS3-11B	GS3-12B	—	—
*Metal Thickness 0.009													
Barrel Diameter 0.121													
Flange Diameter 0.200	—	GS4-3B	GS4-4B	GS4-5B	GS4-6B	GS4-7B	GS4-8B	GS4-9B	GS4-10B	GS4-11B	GS4-12B	—	—
*Metal Thickness 0.010													
Barrel Diameter 0.152													
Flange Diameter 0.245	—	GS5-3B	GS5-4B	GS5-5B	GS5-6B	GS5-7B	GS5-8B	GS5-9B	GS5-10B	—	GS5-12B	—	—
*Metal Thickness 0.010													
Barrel Diameter 0.183													
Flange Diameter 0.290	—	GS6-3B	GS6-4B	GS6-5B	GS6-6B	GS6-7B	GS6-8B	GS6-9B	GS6-10B	GS6-11B	GS6-12B	GS6-13B	GS6-14B
*Metal Thickness 0.011													
Barrel Diameter 0.215													
Flange Diameter 0.340	—	GS7-3B	GS7-4B	GS7-5B	GS7-6B	GS7-7B	GS7-8B	GS7-9B	GS7-10B	GS7-11B	GS7-12B	GS7-13B	GS7-14B
*Metal Thickness 0.011													
Barrel Diameter 0.246													
Flange Diameter 0.385	—	GS8-3B	GS8-4B	GS8-5B	GS8-6B	GS8-7B	GS8-8B	GS8-9B	GS8-10B	GS8-11B	GS8-12B	GS8-13B	GS8-14B
*Metal Thickness 0.011													



STANDARD SPLIT RIVETS AND DRIVE SCREWS

Nom. Shank Dia.	Shank Dia. D	Nom. Head Dia.	Head Dia. A	Head Thick H	D Clinch Allow
3/32	.085 .089	9/64	.138 .145	.026 .030	.062
3/32	.085 .089	5/32	.154 .159	.026 .030	.062
1/8	.116 .121	7/32	.216 .221	.036 .040	.093
1/8	.116 .121	5/16	.307 .312	.055 .063	.093
9/64	.144 .152	5/16	.306 .318	.035 .045	.120
5/32	.150 .155	5/16	.310 .316	.047 .051	.125
5/32	.150 .155	3/8	.373 .380	.064 .068	.125
3/16	.180 .190	5/16	.306 .318	.041 .051	.156
3/16	.180 .190	3/8	.369 .381	.058 .068	.156
1/4	.230 .240	7/16	.426 .431	.099 .104	.187
9/32	.274 .289	1/2	.464 .504	.114 .138	.210

OVAL HEAD

TRUSS HEAD

Prices on countersunk head and special split rivets are available on request.

DRIVE SCREWS - ROUND HEAD TYPE U

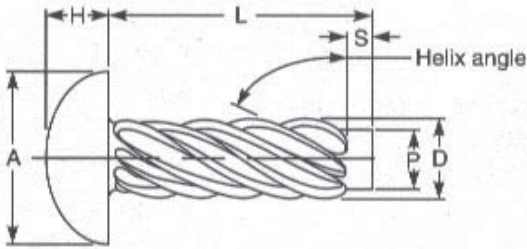

Available in steel and stainless steel.
L (length) dimension determined by customer.

Nominal Screw Size	Number of Thread Starts	D		A		H		P		Recommended Hole Size	
		Outside Diameter		Head Diameter		Head Height		Pilot Diameter		Drill Size No.	Hole Diameter
		Max	Min	Max	Min	Max	Min	Max	Min		
00	6	.060	.057	.099	.090	.034	.026	.049	.046	55	.052
0	6	.075	.072	.127	.118	.049	.041	.063	.060	51	.067
2	8	.100	.097	.162	.146	.069	.059	.083	.080	44	.086
4	7	.116	.112	.211	.193	.086	.075	.096	.092	37	.104
6	7	.140	.136	.260	.240	.103	.091	.116	.112	31	.120
7	8	.154	.150	.285	.264	.111	.099	.126	.122	29	.136
8	8	.167	.162	.309	.287	.120	.107	.136	.132	27	.144
10	8	.182	.177	.359	.334	.137	.123	.150	.146	20	.161
12	8	.212	.206	.408	.382	.153	.139	.177	.173	11	.191
14	9	.242	.236	.457	.429	.170	.155	.202	.198	2	.221



COMPRESSION RIVETS/SPEEDY RIVETS

STEM



CAP



COMPRESSED



PART NUMBER	DIAMETER	HEAD DIAM.	GRIP RANGE	STEM LENGTH
CR-DCSR02 metric	.129" 3.30mm	.222" 5.65mm	.020"-.145" .52mm-3.70mm	.225" 5.75mm
CR-DCSR03 metric	.150" 3.80mm	.275" 7.05mm	.020"-.187" .52mm-4.75mm	.290" 7.40mm
CR-DCSR04 metric	.145" 3.70mm	.365" 9.25mm	.020"-.218" .52mm-5.55mm	.345" 8.80mm
CR-DCSR05 metric	.154" 3.90mm	.355" 9.00mm	.020"-.305" .52mm-7.75mm	.409" 10.40mm
CR-DCSR11 metric	.154" 3.90mm	.437" 11.00mm	.020"-.312" .52mm-7.95mm	.420" 10.70mm
CR-DCSR12 metric	.176" 4.5mm	.500" 13mm	.020"-.312" .52mm-7.95mm	.437" 11mm
CR-DCSR76 metric	.184" 4.80mm	.430" 10.90mm	.020"-.437" .52mm-11.10mm	.550" 13.35mm
CR-DCSR80 metric	.238" 6.30mm	.500" 12.80mm	.250"-.625" 1.55mm-15.90mm	.690" 17.60mm

Add on these prefixes at the end of the number for desired material and plating

- Steel-nickle plated rivet example: CR-DCSR02SN
- Steel-brass plated rivet example: CR-DCSR02SB
- Steel-black plated rivet example: CR-DCSR02SBL
- Brass-plain finish rivet example: CR-DCSR02B
- Brass-nickle plated rivet example: CR-DCSR02BN
- Brass-black plated rivet example: CR-DCSR02BBL



STEEL BARREL NUTS & SCREWS

Steel Zinc Plated Barrel Nuts and Screws also known as Sex Bolts.

Post/Barrels (.250" barrel dia. x .438" head O.D. - Slotted/Phillips combination)

Screws (10-24 thread dia. x .438" head O.D. - Slotted/Phillips combination).

Zinc plated steel. For use in 17/64" holes.

Low profile, matching head on both the bolt and screw allow for a nice clean look.

For use in 17/64" (.265) holes

10-24 Thread Size

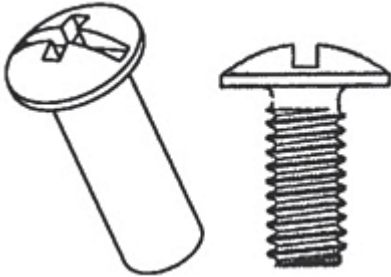

SCREW

10-24 Thread Size

Part Number	Description	Length	Material	Head Style
S-312S	Screw	5/16"	Zinc Plated Steel	Closed End, Combo Drive

POST/BARRELS

1/4 (.250) Outside Diameter and Slotted/Phillips combination

Part Number	Description	Length	Material	Head Style
B-250S	Barrel	1/4"	Zinc Plated Steel	Open End, Slotted Drive
B-375SE	Barrel	3/8"	Zinc Plated Steel	Closed End, Combo Drive
B-500SE	Barrel	1/2"	Zinc Plated Steel	Closed End, Combo Drive
B-625SE	Barrel	5/8"	Zinc Plated Steel	Closed End, Combo Drive
B-750SE	Barrel	3/4"	Zinc Plated Steel	Closed End, Combo Drive
B-1000SE	Barrel	1"	Zinc Plated Steel	Closed End, Combo Drive
B-1250SE	Barrel	1-1/4"	Zinc Plated Steel	Closed End, Combo Drive
B-1500SE	Barrel	1-1/2"	Zinc Plated Steel	Closed End, Combo Drive
B-2000SE	Barrel	2"	Zinc Plated Steel	Closed End, Combo Drive

Steel Barrel Bolt Extension

.250" dia. with 10-24 dia. male and female ends. Zinc plated steel. For use in 17/64" holes.

Part Number	Description	Length	Material
B-EXTS	Bolt Extension	1/2"	Zinc Plated Steel

Note: When used in conjunction with zinc plated Steel Barrel Bolts, extensions add length in order to increase binding capacity as needed.



BRASS BINDER POST & SCREWS



SCREWS - (8-32 thread dia. x .415" head O.D. - slotted). BRASS. For use in 7/32" holes.

Part Number	Description	Length	Material	Head Style
S-187B	Removable Screw	3/16"	Solid Brass	Slotted Drive
S-250B	Removable Screw	1/4"	Solid Brass	Slotted Drive
S-312B	Removable Screw	5/16"	Solid Brass	Slotted Drive

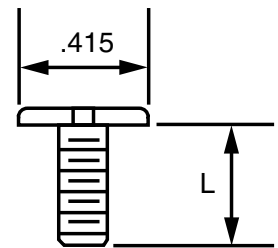

8-32 Thread

POST-have a .203 body diameter x .415 head OD-unslotted.

D=.203 L= see chart below

Part Number	Description	Length	Material	Head Style	Mating Screw (sold separately)
B-125B	Binder Post	1/8"	Solid Brass	Open End, No Drive	S-187B
B-187B	Binder Post	3/16"	Solid Brass	Open End, No Drive	S-250B
B-250B	Binder Post	1/4"	Solid Brass	Open End, No Drive	S-250B
B-375BE	Binder Post	3/8"	Solid Brass	Closed End, No Drive	S-312B
B-500BE	Binder Post	1/2"	Solid Brass	Closed End, No Drive	S-312B
B-625BE	Binder Post	5/8"	Solid Brass	Closed End, No Drive	S-312B
B-750BE	Binder Post	3/4"	Solid Brass	Closed End, No Drive	S-312B
B-1000BE	Binder Post	1"	Solid Brass	Closed End, No Drive	S-312B
B-1250BE	Binder Post	1 1/4"	Solid Brass	Closed End, No Drive	S-312B
B-1500BE	Binder Post	1 1/2"	Solid Brass	Closed End, No Drive	S-312B
B-1750BE	Binder Post	1 3/4"	Solid Brass	Closed End, No Drive	S-312B
B-2000BE	Binder Post	2"	Solid Brass	Closed End, No Drive	S-312B

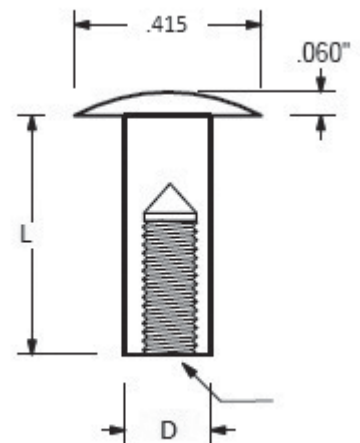



ALUMINUM BINDER POST & SCREWS



203" dia. x .415" head O.D. - unslotted

SCREWS - (8-32 thread dia. x .415" head O.D. - slotted). Aluminum.
For use in 7/32" holes.

	ITEM	LENGTH	HEAD STYLE
S-187A	Removable Screw	3/16"	Slotted Drive
S-250A	Removable Screw	1/4"	Slotted Drive
S-375A	Removable Screw	3/8"	Slotted Drive

BOLT/POST EXTENSIONS

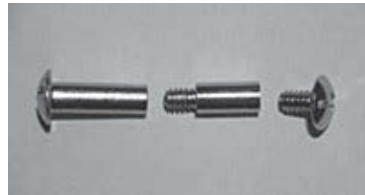

Part Number	Description
B-250AEX	1/4 BOLT EXTENTION, ALUMINUM
B-500AEX	1/2 BOLT EXTENTION, ALUMINUM
B-750AEX	3/4 BOLT EXTENTION, ALUMINUM
B-1000AEX	1" BOLT EXTENTION, ALUMINUM

POST - have a .203 body diameter x .415 head OD-unslotted.

Part Number	Description	Length	Head Style	Mating Screw (sold separately)
B-125A	Binder Post	1/8"	Open End, No Drive	S-187A
B-187A	Binder Post	3/16"	Open End, No Drive	S-250A
B-250A	Binder Post	1/4"	Open End, No Drive	S-250A
B-250AE	Binder Post	1/4"	Closed End, No Drive	S-187A
B-375A	Binder Post	3/8"	Open End, No Drive	S-375A
B-375AE	Binder Post	3/8"	Closed End, No Drive	S-250A
B-500AE	Binder Post	1/2"	Closed End, No Drive	S-375A
B-625AE	Binder Post	5/8"	Closed End, No Drive	S-375A
B-750AE	Binder Post	3/4"	Closed End, No Drive	S-375A
B-875AE	Binder Post	7/8"	Closed End, No Drive	S-375A
B-1000AE	Binder Post	1"	Closed End, No Drive	S-375A
B-1250AE	Binder Post	1-1/4"	Closed End, No Drive	S-375A
B-1500AE	Binder Post	1-1/2"	Closed End, No Drive	S-375A
B-1750AE	Binder Post	1-3/4"	Closed End, No Drive	S-375A
B-2000AE	Binder Post	2"	Closed End, No Drive	S-375A
B-2250AE	Binder Post	2-1/4"	Closed End, No Drive	S-375A
B-2500AE	Binder Post	2-1/2"	Closed End, No Drive	S-375A
B-2750AE	Binder Post	2-3/4"	Closed End, No Drive	S-375A
B-3000AE	Binder Post	3"	Closed End, No Drive	S-375A
B-3250AE	Binder Post	3-1/4"	Closed End, No Drive	S-375A
B-3500AE	Binder Post	3-1/2"	Closed End, No Drive	S-375A
B-4000AE	Binder Post	4"	Closed End, No Drive	S-375A
B-4500AE	Binder Post	4-1/2"	Closed End, No Drive	S-375A
B-5000AE	Binder Post	5"	Closed End, No Drive	S-375A
B-6000AE	Binder Post	6"	Closed End, No Drive	S-375A



BLACK ANODIZED ALUMINUM BINDER POST & SCREWS



SCREWS - (8-32 thread dia. x .415" head O.D. - slotted). Aluminum. For use in 7/32" holes.

Part Number	Description	Length	Material	Head Style
S-187AB	Removable Screw	3/16"	Black Anodized Aluminum	Slotted Drive
S-250AB	Removable Screw	1/4"	Black Anodized Aluminum	Slotted Drive
S-375AB	Removable Screw	3/8"	Black Anodized Aluminum	Slotted Drive

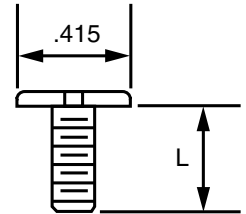

8-32 Thread

POST-have a .203 body diameter x .415 head OD-unslotted.
D=.203 L= see chart below

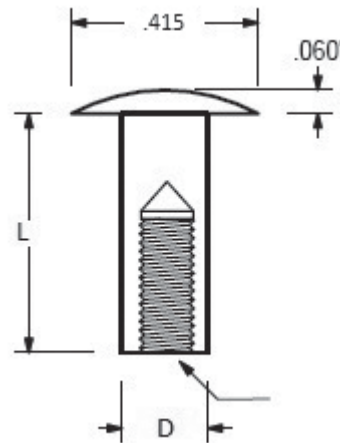

Part Number	Description	Length	Material	Head Style	Mating Screw (sold separately)
B-125AB	Binder Post	1/8"	Black Anodized Aluminum	Open End, No Drive	S-187AB
B-187AB	Binder Post	3/16"	Black Anodized Aluminum	Open End, No Drive	S-250AB
B-250AB	Binder Post	1/4"	Black Anodized Aluminum	Open End, No Drive	S-250AB
B-375AB	Binder Post	3/8"	Black Anodized Aluminum	Open End, No Drive	S-375AB
B-500ABE	Binder Post	1/2"	Black Anodized Aluminum	Closed End, No Drive	S-375AB
B-625ABE	Binder Post	5/8"	Black Anodized Aluminum	Closed End, No Drive	S-375AB
B-750ABE	Binder Post	3/4"	Black Anodized Aluminum	Closed End, No Drive	S-375AB
B-1000ABE	Binder Post	1"	Black Anodized Aluminum	Closed End, No Drive	S-375AB
B-1250ABE	Binder Post	1 1/4"	Black Anodized Aluminum	Closed End, No Drive	S-375AB
B-1500ABE	Binder Post	1 1/2"	Black Anodized Aluminum	Closed End, No Drive	S-375AB
B-1750ABE	Binder Post	1 3/4"	Black Anodized Aluminum	Closed End, No Drive	S-375AB
B-2000ABE	Binder Post	2"	Black Anodized Aluminum	Closed End, No Drive	S-375AB



PLASTIC BINDER POSTS & SCREWS

Large, low profile matching slotted heads on both the post and screw allow for a nice, clean look. Screw can be pushed in for fast assembly. For best results, insert screw length completely.

Removable and reusable. Each assembly consists of one post and one screw. Binding capacity is determined by length of post used. Otherwise known as Quick-Connect or Adjust-A-Locks

- Female posts are .240" barrel dia. x .562" head O.D. - slotted
- Male screws are 10-24 thread dia. x .562" head O.D. - slotted
- For use in 1/4" holes
- Available in Black or White

POSTS AND SCREWS SOLD SEPARATELY

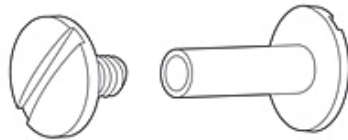

Black					
PART #	Item	Length	Head Type	Color	Mating Screw (sold separately)
S-250PB	Removable Screw	1/4	Slotted Drive	black	
S-375PB	Removable Screw	3/8	Slotted Drive	black	
B-250PBE	Binder Post	1/4	Closed End, Slotted Drive	black	S-250PB
B-375PBE	Binder Post	3/8	Closed End, Slotted Drive	black	S-375PB
B-500PBE	Binder Post	1/2	Closed End, Slotted Drive	black	S-375PB
B-750PBE	Binder Post	3/4	Closed End, Slotted Drive	black	S-375PB

White					
PART #	Item	Length	Head Type	Color	Mating Screw (sold separately)
S-250PW	Removable Screw	1/4	Slotted Drive	white	
S-375PW	Removable Screw	3/8	Slotted Drive	white	
B-250PWE	Binder Post	1/4	Closed End, Slotted Drive	white	S-250PW
B-375PWE	Binder Post	3/8	Closed End, Slotted Drive	white	S-375PW
B-500PWE	Binder Post	1/2	Closed End, Slotted Drive	white	S-375PW
B-750PWE	Binder Post	3/4	Closed End, Slotted Drive	white	S-375PW



HAIRPIN COTTERS & COTTER PINS

CLEVIS PINS

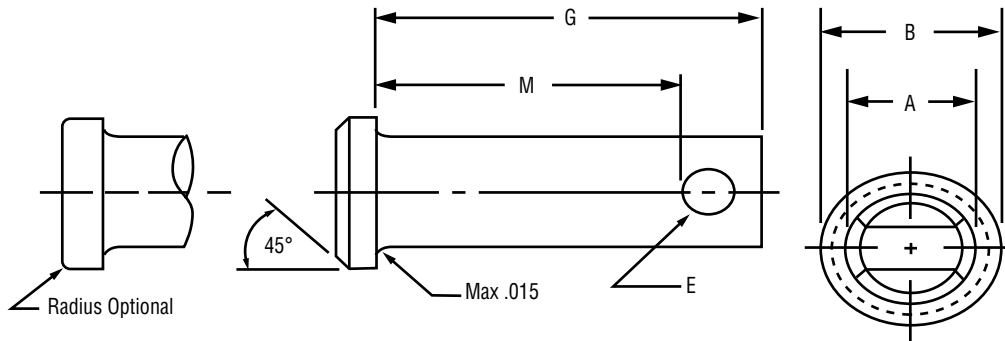

Available in Plain steel, zinc plated steel, or 18-8 Stainless Steel

Nominal Diameter	Head Diameter	Length	Length to Hole	Hole Diameter	
A	B	G	M	E	
3/16"	.181/.186	.302/.320	*available from 1/2" to 3"	*variable dependent on length	.088/.103
1/4 "	.243/.248	.365/.380	*available from 1/2" to 3-1/2"		.088/.103
5/16"	.306/.311	.432/.444	*available from 1/2" to 3-1/2"		.135/.150
3/8"	.368/.373	.490/.510	*available from 1/2" to 4"		.151/.166
7/16"	.431/.436	.552/.570	*available from 1/2" to 4"		.151/.166
1/2"	.491/.496	.615/.630	*available from 1/2" to 4-1/2"		.151/.166

COTTER PINS

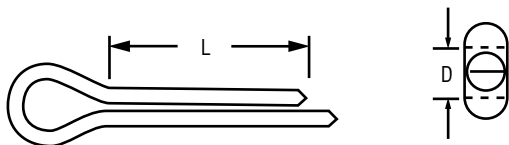

"D" Dimension	"L" Dimension
1/32	available from 3/8" to 3/4"
3/64	available from 5/16" to 1-1/2"
1/16	available from 1/4" to 3"
5/64	available from 1/2" to 3"
3/32	available from 1/2" to 3"
7/64	available from 1/2" to 3"
1/8	available from 1/2" to 5"
9/64	available from 3/4" to 4"
5/32	available from 3/4" to 4"
3/16	available from 3/4" to 4"
7/32	available from 1" to 6"
1/4	available from 3/4" to 6"
5/16	available from 1" to 6"
3/8	available from 1-1/2" to 7"
7/16	available from 2" to 6"
1/2	available from 2" to 6"
5/8	available from 3" to 7"
3/4	4"

HAIR PIN COTTERS (Bridge Pins)

Hairpin Cotters are reusable and ideal for quick assembly and disassembly applications. They are available in high quality, zinc plated 1050 spring wire.

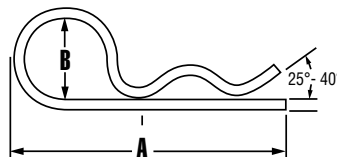

Use On Shaft Size	Product Code	Wire Diameter	(A)	(B)
3/16 - 1/4	21-02	0.042	15/16	1/4
5/16 - 3/8	21-04	0.073	1-7/16	3/8
3/8 - 7/16	21-05	0.092	1-7/8	5/8
1/2 - 5/8	21-06	0.120	2-3/8	23/32
5/8 - 3/4	21-07	0.148	2-11/16	25/32
7/8 - 1	21-08	0.178	3-3/4	1-1/32



CLECO FASTENERS/TEMPORARY RIVETS

Cleco fasteners provide the quickest method for holding sheets together for drilling or riveting. Drill the size hole needed for the rivet and insert the sheet holder. The Cleco fasteners listed comprise the most common sizes. Material thickness range 0" - 1/4". Cleco fasteners are color coded for easy identification. Use with Cleco fastener pliers.



Cleco Fasteners



Cleco Pliers

Standard Style Cleco Fasteners

No.	Color	Grip	OAL	Size
CL-215	Zinc	0" - 1/4"	2 - 1/4"	3/32
CL-216	Copper	0" - 1/4"	2 - 1/4"	1/8
CL-217	Black	0" - 1/4"	2 - 1/4"	5/32
CL-218	Brass	0" - 1/4"	2 - 1/4"	3/16
CL-219	Copper	0" - 1/4"	2 - 1/4"	1/4

Stubby Cleco Fasteners

No.	Color	Grip	OAL	Size
CL-457	Zinc	0" - 1/4"	1" - 3/4"	3/32
CL-458	Copper	0" - 1/4"	1" - 3/4"	1/8
CL-459	Black	0" - 1/4"	1" - 3/4"	5/32
CL-460	Brass	0" - 1/4"	1" - 3/4"	3/16

Long Style Cleco Fasteners

No.	Color	Grip	OAL	Size
CL-453	Zinc	1/4" - 1/2"	2" - 1/2"	3/32
CL-454	Copper	1/4" - 1/2"	2" - 1/2"	1/8
CL-455	Black	1/4" - 1/2"	2" - 1/2"	5/32
CL-456	Brass	1/4" - 1/2"	2" - 1/2"	3/16

Extended Grip - Heavy Duty Cleco Fasteners

No.	Color	Grip	OAL	Size
CL-461	Zinc	0" - 1/2"	2" - 1/2"	3/32
CL-462	Copper	0" - 1/2"	2" - 1/2"	1/8
CL-463	Black	0" - 1/2"	2" - 1/2"	5/32
CL-464	Brass	0" - 1/2"	2" - 1/2"	3/16



RIVET SETS - SQUEEZERS - TOOLS

RIVET SETS

TUBULAR RIVET SETS

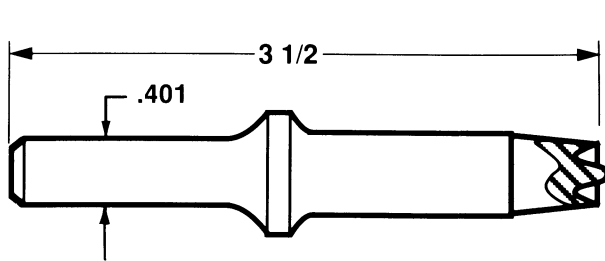

**.401 SHANK
DIA.**

SOLID RIVET SETS

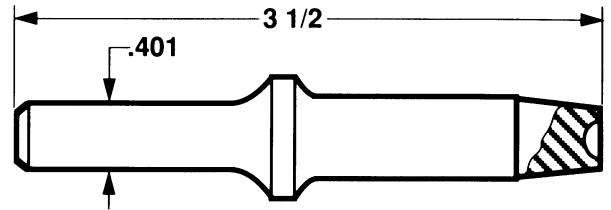

RIVET SIZE	PART NUMBER
1/16	4502
3/32	4503
1/8	4504
5/32	4505
3/16	4506
1/4	4508
5/16	45010
3/8	45012

DESCRIPTION	1/16	3/32	1/8	5/32	3/16	1/4
Round - AN 430	4302	4303	4304	4305	4306	4308
Flat - AN 442	4422	4423	4424	4425	4426	4428
Brazier - AN 455	4552	4553	4554	4555	4556	4558
Mod. Brazier - AN 456	4562	4563	4564	4565	4566	4568
Universal - AN 470	4702	4703	4704	4705	4706	4708

HAND RIVET SQUEEZERS



MODEL	RIVET CAPACITY	YOKE		LENGTH	WEIGHT
		REACH	GAP		
TP-888-15	3/32 thru 3/16"	1-1/2"	1-1/4"	14"	2-1/2 LBS.
TP-888-3	3/32 thru 3/16"	3"	1-1/4"	14"	2.9 LBS.

PNEUMATIC RIVETERS

RIVET SQUEEZERS



- Various Capacities depending on model.
- Available in both "C" yokes and Alligator styles.

RIVET GUNS/RIVET HAMMERS



- Various Capacities depending on model
- Ranging from 3/16 to 5/16 in solid steel.

NOTE: A variety of solid rivet installation tools available upon request.



MS & AN SOLID RIVETS

ILLUSTRATIONS OF POPULAR HEAD STYLES AND STANDARD HEAD MARKINGS

A 1100 (2S) NO MARK	AN430A ROUND HEAD	MS20426A 100° C'SUNK	MS20470A UNIVERSAL	AN455A BRAZIER		AN456A MODIFIED BRAZIER
AD 2117-T4 (A17ST) DIMPLE	AN430AD ROUND HEAD	MS20426AD 100 C'SUNK	MS20470AD UNIVERSAL	AN455AD BRAZIER		AN456AD MODIFIED BRAZIER
D 2017-T4 (17ST) RAISED DOT	AN430D ROUND HEAD	MS20426D 100° C'SUNK	MS20470D UNIVERSAL	AN455D BRAZIER		AN456D MODIFIED BRAZIER
DD 2024-T4 (24ST) RAISED RAISED DOT	AN430DD ROUND HEAD	MS20426DD 100° C'SUNK	MS20470DD UNIVERSAL	AN455DD BRAZIER		AN456DD MODIFIED BRAZIER
B 5056 (56S) RAISED CROSS	AN430B ROUND HEAD	MS20426B 100° C'SUNK	MS20470B UNIVERSAL	AN455B BRAZIER		AN456B MODIFIED BRAZIER
C COPPER NO MARK	MS20435C ROUND HEAD	MS20427C 100° C'SUNK	MS20615CU UNIVERSAL	AN420C 90° C'SUNK	AN441C FLAT HEAD	
F STAINLESS STEEL	MS20435F ROUND HEAD	MS20427F 100° C'SUNK	MS20613F UNIVERSAL			
M MONEL	MS20435M ROUND HEAD	MS20427M 100° C'SUNK	MS20615M UNIVERSAL		AN441M FLAT HEAD	
STEEL RECESSED TRIANGLE	MS20435 ROUND HEAD	MS20427 100° C'SUNK	MS20613 UNIVERSAL	AN20 90° C'SUNK	AN441 FLAT HEAD	

- AN470 SUPERSEDES AN430, AN442, AN455 & AN456 IN MOST APPLICATIONS.
- AN425 INACTIVE.
- Example: AN-470-AD-4-8

AN - When these two letters precede numbers, they indicate Army and Navy specifications.

MS - When these two letters precede numbers, they indicate Military Standard specifications.

470 - The first three numbers indicate the type of head:
470 = universal head, 430 = round head, etc.

AD - Letters following head type code indicate material:

A = 1100(2S) aluminum, AD = 2117-T4 (A17ST), etc.

4 - First numbers after material code indicate diameter of rivet in 32nds of an inch. 4 = 4/32" or 1/8", 12 = 12/32" or 3/8", etc.

8 - Last numbers indicate length of rivet in 16ths of an inch:
8 = 8/16" or 1/2", 10 = 10/16" or 5/8", etc.



jay-cee sales & rivet inc.
"THE QUALITY RIVET PEOPLE"

*You, our customer, are the reason we're in business. It is our quality, service and desire to please that makes **Jay-Cee Sales & Rivet** your #1 choice.*

***Jay-Cee Sales & Rivet** maintains the nation's largest in-stock inventory, supplying rivets and special fasteners since 1948! We take great pride in offering any type, any metal, any size to fit your rivet needs. We also offer a full line of rivet tools and accessories.*

***Jay-Cee Sales & Rivet** gives you same day service on most orders. Order it today, we'll ship it today!*

*On behalf of **Jay-Cee Sales & Rivet** we thank you for this opportunity to serve you. For added convenience and speed in ordering feel free to use our fax number or call Toll Free today!*

32861 Chesley Drive
Farmington, Michigan 48336

PHONE: (248) 478-2150

Fax: (248) 478-6416

Web address: www.rivetsinstock.com

E-mail: Sales@rivetsinstock.com



jay-cee sales & rivet inc.
"THE QUALITY RIVET PEOPLE"



www.rivetsinstock.com

32861 Chesley Drive, Farmington, MI 48336

Phone: (248) 478-2150 Fax: (248) 478-6416

email: sales@rivetsinstock.com