

CB-OBS410 ELECTRICAL MECHANICAL DATA SHEET

Document Revision

Document number: 6553614

Release: Apr 14, 2014 16:28

Document version: [13](#)

Copyright © 2014 u-blox AG. The contents of this document can be changed by u-blox AG without prior notice and do not constitute any binding undertakings from u-blox AG. u-blox AG is not responsible under any circumstances for direct, indirect, unexpected damage or consequent damage that is caused by this document. All rights reserved. All brand and product names are trademarks or service marks of their respective owners.

1 Table of Content

- 1 [Table of Content](#)
- 2 [Introduction](#)
 - 2.1 [Related Documents](#)
 - 2.2 [Product Variants](#)
 - 2.3 [Block Diagram](#)
- 3 [Electrical Interface and Connectors](#)
 - 3.1 [Pin Numbering](#)
 - 3.2 [Pin Description](#)
 - 3.3 [Characteristics](#)
 - 3.4 [Hardware Reset](#)
- 4 [Operating Status](#)
- 5 [Antennas](#)
 - 5.1 [Surface Mounted Antennas \(Internal\)](#)
 - 5.2 [External antennas](#)
- 6 [Mechanics](#)
 - 6.1 [Module Outlines](#)
 - 6.2 [Using the J2/J3 Board-to-Board Connectors](#)
 - 6.3 [Using Press-Fit Nuts for Mounting the Module](#)
 - 6.4 [Using the J6 PCB solder pads](#)
 - 6.5 [Antenna Issues](#)
- 7 [Bluetooth Information](#)
 - 7.1 [General information](#)
 - 7.2 [Bluetooth Qualification information](#)
- 8 [Regulatory Information](#)
 - 8.1 [Declaration of Conformity](#)
 - 8.2 [Safety Compliance](#)
 - 8.3 [FCC and IC Compliance](#)
 - 8.4 [UL listing information](#)
 - 8.5 [Japan Radio Equipment Compliance \(TELEC\)](#)
 - 8.6 [Compliance with RoHS directive](#)
- 9 [Guidelines for Efficient and Safe Use](#)
 - 9.1 [General](#)
 - 9.2 [Product Care](#)
 - 9.3 [Radio Frequency Exposure](#)
 - 9.4 [Electronic Equipment](#)
 - 9.5 [Potentially Explosive Atmospheres](#)
 - 9.6 [Power Supply](#)
- 10 [Application Notes](#)
 - 10.1 [Step-by-Step Guide](#)
 - 10.2 [Design Examples](#)

2 Introduction

The hardware of the cB-OBS410 products are referred as cB-0925 and the module is Type Approved with the type name cB-0925.

The cB-OBS410 is a small size Bluetooth module based on the ST-Ericsson STLC2500 radio chip and a ST Microelectronics STM32F10x microprocessor. The module is available in different configuration (see [Product Variants](#)) with [Internal antennas](#) or a U.FL. connector for connecting an [external antenna](#).



Figure 1: cB-OBS410i-04 OEM Serial Port Adapter with internal antenna

2.1 Related Documents

There are some documents related to the Serial Port Adapter:

- The [Bluetooth Serial Port Adapter AT Commands](#) document contains a description of the AT commands supported in the Serial Port Adapter. It also contains information on how to use the AT commands to create Bluetooth applications.
- The [cB-OBS410 Electrical & Mechanical Datasheet](#) (this document) contains important information about the OEM Serial Port Adapter. Read this document if you are using the OEM Serial Port Adapter.
- The [Bluetooth Qualification Guide](#) contains a step by step guide that describes how to create a Bluetooth end product listing for products integrating the cB-OBS410.

2.2 Product Variants

The module is available in three antenna options. Please note that the j-version (extra low antenna profile) is available on special request only, since the antenna performance may be limited because of the small size of the antenna.

Table 1: Product variants

Product Name	Regulatory ID / FCC ID / IC ID	Bluetooth Type	Description	
cB-OBS410i-04	cB-0925 / PVH0925 / 5325A-0925	Classic Bluetooth Class 1	OEM Serial Port Adapter 410 with internal antenna, board-to-board and solder pads.	
cB-OBS410x-04	cB-0925 / PVH0925 / 5325A-0925	Classic Bluetooth Class 1	OEM Serial Port Adapter 410 with U.FL. connector for external antenna, board-to-board and solder pads.	
cB-OBS410j-04	cB-0925 / PVH0925 / 5325A-0925	Classic Bluetooth Class 1	OEM Serial Port Adapter 410 with internal antenna (extra low antenna profile), board-to-board and solder pads. Available on special request only.	

2.3 Block Diagram

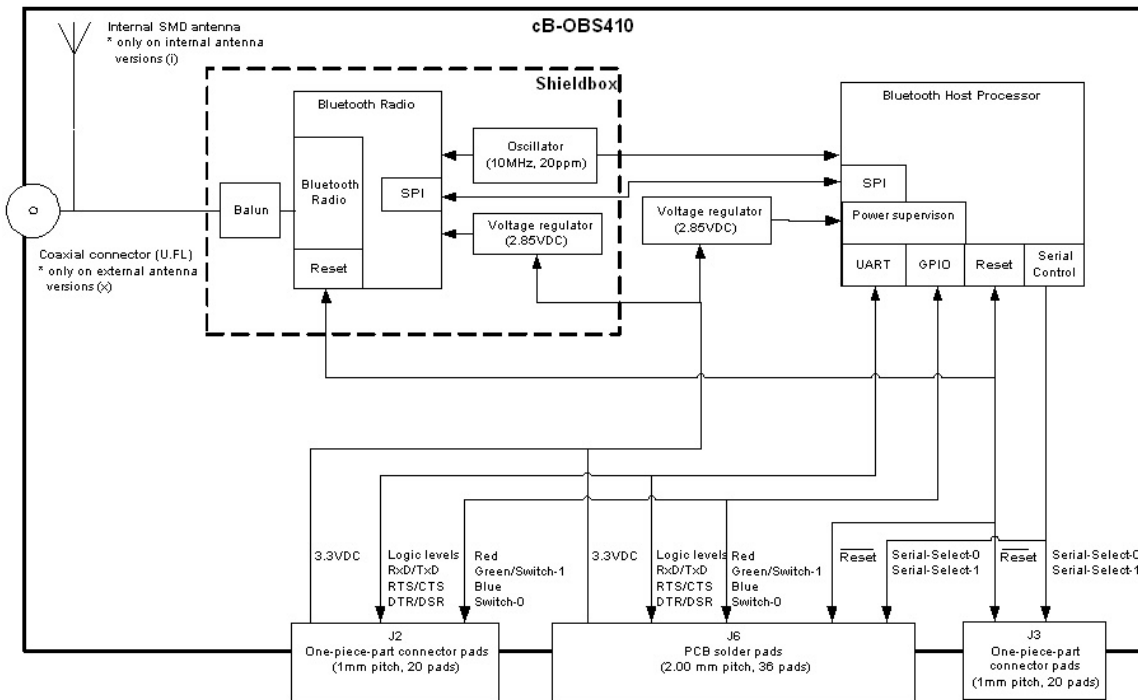

Figure 2: Block diagram of cB-OBS410

3 Electrical Interface and Connectors

This section describes the signals available on the module interface connectors. There are three ways to connect to the OEM Serial Port Adapter:

- Via the PCB solder pads on the edge of the PCB, J6 (see Figure 3). See Section [Using the J6 PCB solder pads](#) for more information.
- Via the 2x20-pin 1mm pitch board-to-board (one piece part) connectors, J2 through J3. The J2 to J3 connectors on the OEM Serial Port Adapter exist on the module only as a mating PCB-layout pattern (see Figure 3). See Section [Using the J2/J3 Board-to-Board Connectors](#) for more information.

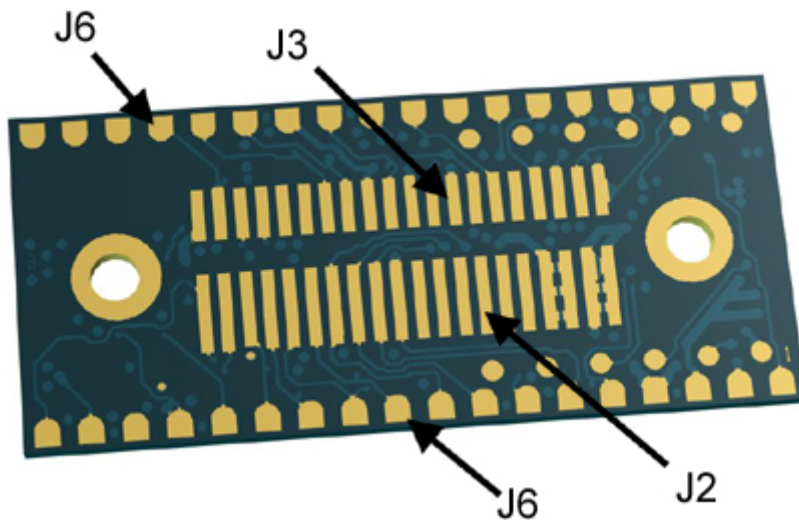

Figure 3: The solder pads J6 are available on the long edges of the bottom side of the PCB. The board-to-board connector pads J2-J3 are located between the mounting holes.

3.1 Pin Numbering

3.1.1 J2, J3 and J6 bottom side connectors

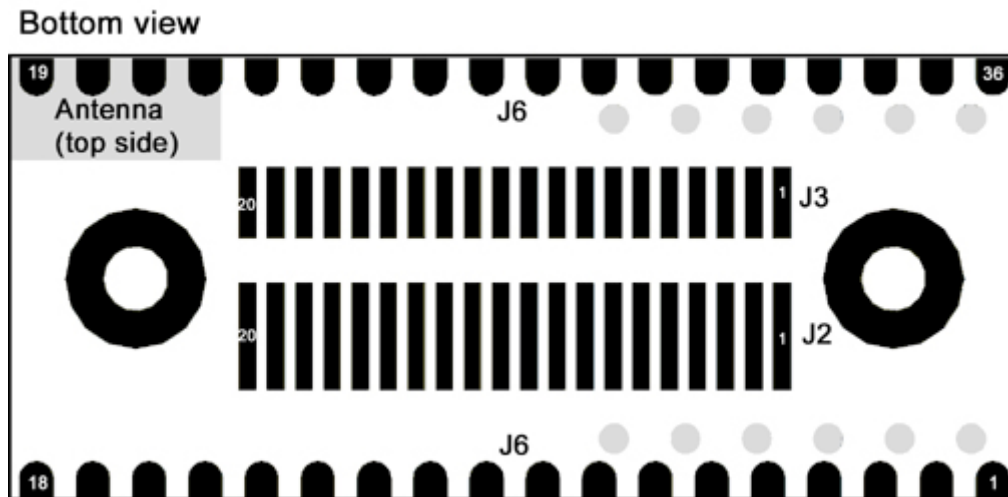



Figure 4: Bottom view of the PCB with the pin numbering of the J2, J3 and the J6 connectors.

3.2 Pin Description

Table 2: Signals description.

J2 Pin Nbr	J3 Pin Nbr	J6 Pin Nbr	Signal Name	Signal Level	Type	IO pin Nbr	Description
1-2	8, 12	3, 25***	VSS	Ground		-	GND
3-4	-	4	VCC_3V3	3.3 V	In	-	3.0 - 6.0 VDC power supply
5-10	5, 15-18	14-17, 19-21, 29	-	-	-	-	Reserved, do not connect.
-	14	23	-	CMOS	In/Out	10	AT command controlled IO pin. See the "Bluetooth Serial Port Adapter AT Commands" documentation for more info.
-	13	24	-	CMOS	In/Out	11	AT command controlled IO pin. See the "Bluetooth Serial Port Adapter AT Commands" documentation for more info.
-	11	26	-	CMOS	In/Out	12	AT command controlled IO pin. See the "Bluetooth Serial Port Adapter AT Commands" documentation for more info.
-	7	27	-	CMOS	In/Out	13	AT command controlled IO pin. See the "Bluetooth Serial Port Adapter AT Commands" documentation for more info.
-	6	28	-	CMOS	In/Out	14	AT command controlled IO pin. See the "Bluetooth Serial Port Adapter AT Commands" documentation for more info.
-	1	31	-	CMOS	In/Out	15	AT command controlled IO pin. See the "Bluetooth Serial Port Adapter AT Commands" documentation for more info.
-	2	32	-	CMOS	In/Out	16	AT command controlled IO pin. See the "Bluetooth Serial Port Adapter AT Commands" documentation for more info.

-	3	33	-	CMOS	In/Out	17	AT command controlled IO pin. See the "Bluetooth Serial Port Adapter AT Commands" documentation for more info.
-	4	34	-	CMOS	In/Out	18	AT command controlled IO pin. See the "Bluetooth Serial Port Adapter AT Commands" documentation for more info.
11	-	7	RED/Mode	CMOS	Out	2	<p>RED:Logic Red LED Signal (see the Operating Status section). Active low.</p> <p>Mode: Not used on cB-OBS410. This pin is also used to select Logic level mode (instead of RS232) for connectBlue products with internal RS232 driver. To be compatible with these products check the datasheet for these products about this signal.</p>
12	-	6	Switch-0	CMOS	In	1	<p>Used for the "Connect on external signal" function, see the Serial Port Adapter AT command Specification for more information on the Function switch. Active low.</p> <p>A secondary function is that the module will restore all factory settings if both the Switch-1 and Switch-0 signals are low during start up.</p> <p>See the Serial Port Adapter AT command Specification for more information on the Restoring Default Configuration functionality.</p> <p>See section Switch-0 Signal for design examples.</p>

13	-	8	GREEN/Switch-1	CMOS	In/Out	3	<p>This signal is multiplexed: GREEN:Logic Green LED Signal (see the Operating Status section). Not valid until 500ms after startup. Active low.</p> <p>Switch-1: If the level on this pin is pulled-down** the unit goes back to default serial settings. The Switch-1 input is only active during the first 500ms after startup. The module will restore all factory settings if both the Switch-1 and Switch-0 signals are low during start up.</p> <p>See the Serial Port Adapter AT command Specification for more information on the Restoring Default Configuration functionality.</p> <p>See section GREEN/Switch-1 for design examples.</p>
14	-	9	BLUE	CMOS	Out	4	<p>Logic Blue LED Signal (see the Operating Status section). Active low. Note: Signal will flicker at data transmission.</p> <p>See section BLUE Signal for design examples.</p>
15	-	10	UART-CTS*	CMOS	In	5	Clear To Send. Hardware flow control. Active low.
16	-	11	UART-TxD*	CMOS	Out	6	Transmit Data. "0" : Low, "1" : High
17	-	12	UART-RTS*	CMOS	Out	7	Request To Send. Hardware flow control. Active low.
18	-	13	UART-RxD*	CMOS	In	8	Receive Data. "0" : Low, "1" : High
19	-	5	UART-DTR*	CMOS	Out	0	Data Terminal Ready. Active low.
20	-	18, 30***	UART-DSR*	CMOS	In	9	Data Set Ready. Active low.
-	19	1, 22***	 RESET	CMOS	In		Hardware reset
-	9	36	SerialSelect-0	CMOS	Out	20	Control signal for external serial transceivers. See Serial Interface section for more info.

-	10	35	SerialSelect-1	CMOS	Out	19	Control signal for external serial transceivers. See Serial Interface section for more info.
-	20	2	VCC_2V85	2.85 V	Out	-	Regulated interface voltage for voltage level shifting, max 10mA.

* All signals are logic level UART signals (typically 0 - 2.85VDC).

** Use max 4.7kOhm as pull-down which is different to previous product generations from connectBlue.

*** Alternative signal pin recommended to use in new designs (both signal pins should be connected).

3.3 Characteristics

The cB-OBS410 module has linear power supplies, which means that the current is constant if the voltage supply is changed.

3.3.1 Power supply

NOTE

Read the [Guidelines for Efficient and Safe Use](#) before using the modules.

Table 3: Power supply

Symbol	Parameter		Value	Unit
VCC_3V3	Power supply (Unregulated*)	Min	3.0	VDC
		Max	6.0	VDC

The module is equipped with internal linear voltage regulators.

Table 4: Current consumption

Symbol	Mode		Value	Unit	
I_{CC} @ VCC_3V3 = 3.3V	Not connected	Connectable, discoverable	Average	14.5	mA
			Peak	64.5	mA
	Connected	Idle or Receiving	Average	15.5	mA
			Peak	57.8	mA
	Transmitting @115.2kbit/s		Average	25.1	mA
			Peak	64.9	mA

	Inquiry		Average	35.5	mA
			Peak	71.0	mA

3.3.2 Input/Output signals

Table 5: Input/output signals

Symbol	Parameter		Value	Unit
V_{IN} Low	Logic LOW level input voltage	Min	-0.50	V
		Max	0.80	V
V_{IN} High	Logic HIGH level input voltage	Min	2.00	V
		Max	3.35	V
V_{OUT} Low	Logic LOW level output voltage	Max	0.40	V
V_{OUT} High	Logic HIGH level output voltage	Min	2.40	V
I_{IO}	Sink and source current	Max	4	mA
C_{IO}	I/O pin capacitance	Typ	5	pF
$R_{IN_PULL-UP}$	Input signals (including \overline{RESET}) internal pull-up	Min	30	kOhm
		Typ	40	kOhm
		Max	50	kOhm
t_{Reset}	Reset pulse length	Min	300	ns

3.3.3 Environmental

Table 6: Temperatures characteristics

Parameter		Value	Unit
Storage temperature	Min	-40	°C
	Max	+125	°C

Operating temperature	Min	-30	°C
	Max	+85	°C

3.4 Hardware Reset

A hardware $\overline{\text{RESET}}$ input is available on the J3 and J6 connectors (see [Pin Numbering](#)). An external reset source must be open drain collector, see section [Reset](#) for design examples. The $\overline{\text{RESET}}$ pin is internally pulled-up with 30kOhm. All signal pins are floating in reset state.

4 Operating Status

The module can be in different modes (see the Serial Port Adapter AT command Specification for more information about the modes) and the RED, GREEN and BLUE signals can be used to detect or indicate the status. The LED signals are active LOW.

Table 7: Signal states in different module modes

Serial Port Adapter Mode	Status	RGB LED Color	GREEN GPIO	BLUE GPIO	RED GPIO
Data mode	IDLE	Green	LOW	HIGH	HIGH
AT mode	IDLE	Orange	LOW	HIGH	LOW
Data mode, AT mode	CONNECTING*	Purple	HIGH	LOW	LOW
Data mode, AT mode	CONNECTED*	Blue	HIGH	LOW	HIGH

*On data activity the active LEDs flashes and will be HIGH for 50-100ms. For information on how to suppress the flashes see section [BLUE Signal](#).

DTR signal can be set to indicate an active Bluetooth link. For more information see Serial Port Adapter AT command Specification.

5 Antennas

This chapter gives a quality overview of the different antenna options.

There are 2 different antenna options available:

- Internal surface mounted (SMD) antenna.
- An U.FL. connector for external antennas. Different types of external antennas are available.

The sections below lists the antennas that are included in the radio type approvals of the module. For each antenna the "Approvals" field defines in which test reports the antenna is included. Definitions of the "Approvals" field are:

- **FCC** - The antenna is included in the FCC test reports, and thus approved for use in countries that accept the FCC radio approvals, primarily US.
- **IC** - The antenna is included in the IC (Industrie Canada) test reports, and thus approved for use in countries that accept the IC radio approvals, primarily Canada.
- **R&TTE** - The antenna is included in the R&TTE test reports, and thus approved for use in countries that accept the R&TTE radio approvals, primarily the European countries.
- **TELEC** - The antenna is included in the Japanese government affiliated TELEC test reports, and thus approved for use in the Japanese market.

In general, antennas with SMD antenna, Reverse Polarity SMA connector or U.FL connector are included in FCC, IC, R&TTE and TELEC radio tests. Antennas with SMA connector are in general included in R&TTE and TELEC radio tests but not FCC or IC due to FCC/IC regulations.

5.1 Surface Mounted Antennas (Internal)

Part Number	OBS411i	
Antenna name	FR05-01-N-0-102	
Manufacture	Fractus	
Gain	1 dBi	
Antenna size (LxWxH)	7.0 x 3.0 x 2.0 mm	
Comment	The antenna gain is very dependent of the mounting of the module. See section Antenna Issues for mounting the module considering the antenna.	
Approval	FCC, IC, R&TTE and TELEC	

Part Number	OBS411j	
Antenna name	FR05-01-N-0-104	
Manufacture	Fractus	
Gain	0 dBi	
Antenna size (LxWxH)	7.0 x 3.0 x 1.0 mm	
Comment	<p>The antenna gain is very dependent of the mounting of the module. See section Antenna Issues for mounting the module considering the antenna. Please note that this version is only available on special request. The antenna performance is limited because of the small size of the antenna.</p>	
Approval	FCC, IC, R&TTE and TELEC	

5.2 External antennas

The external antennas are connected to the board through a U.FL connector. Some of the antennas are connected directly to the U.FL connector of the board and some are connected using an SMA or reversed polarity SMA connector through a short U.FL to SMA or reversed polarity SMA adapter cable.

Antennas with a part number in the form "cB-ACC-XX" are available for orders via the connectBlue distribution network.

For information about other antennas please contact connectBlue

5.2.1 Antenna Accessories

Part Number	cB-ACC-18 / cB-ACC-48	
Name	U.FL to SMA adapter cable	
Connector	U.FL and SMA jack (outer thread and pin receptacle)	
Cable length	120 mm	
Cable loss	Less than 0.5dB	
Comment	The SMA connector may be mounted in a panel.	
Approval	R&TTE and TELEC	

Part Number	cB-ACC-38	
Name	U.FL to reverse polarity SMA adapter cable	

Connector	U.FL and reverse polarity SMA jack (outer thread and pin)	
Cable length	120 mm	
Cable loss	Less than 0.5dB	
Comment	The reverse polarity SMA connector may be mounted in a panel.	
Approval	FCC, IC, R&TTE and TELEC	

5.2.2 Recommended antennas



Part Number	cB-ACC-61	
Name	Ex-IT 2400 RP-SMA 28-001	
Manufacture	ProAnt	
Polarization	Vertical	
Gain	+3.0 dBi	
Size	Ø 12.0 x 28.0 mm	
Connector	Reverse Polarity SMA plug (inner thread and pin receptacle)	
Comment	To be mounted on the U.FL to Reverse Polarity SMA adapter cable (cB-ACC-38). An SMA version antenna is also available but not recommended to use (Ex-IT 2400 SMA 28-001).	
Approval	FCC, IC, R&TTE and TELEC	

Part Number	cB-ACC-63	
Name	Ex-IT 2400 MHF 28	
Manufacture	ProAnt	
Polarization	Vertical	
Gain	+2.0 dBi	
Size	Ø 12.0 x 28.0 mm	
Cable length	100 mm	

Connector	U.FL. connector	
Comment	To be mounted on the U.FL connector on the PCB.	
Approval	FCC, IC, R&TTE and TELEC	

Part Number	cB-ACC-64	
Name	Ex-IT 2400 RP-SMA 70-002	
Manufacture	ProAnt	
Polarization	Vertical	
Gain	+3.0 dBi	
Size	Ø 10 x 83 mm	
Connector	Reverse Polarity SMA plug (inner thread and pin receptacle)	
Comment	To be mounted on the U.FL to Reverse Polarity SMA adapter cable (cB-ACC-38). An SMA version antenna is also available but not recommended to use (Ex-IT 2400 SMA 70-002).	
Approval	FCC, IC, R&TTE and TELEC	

Part Number	cB-ACC-60	
--------------------	------------------	--

Name	Ex-IT 2400 MHF 70-001	
Manufacture	ProAnt	
Polarization	Vertical	
Gain	+3.0 dBi	
Size	Ø 9.4 x 70.5 mm	
Cable length	100 mm	
Connector	U.FL. connector	
Comment	To be mounted on the U.FL connector on the PCB.	
Approval	FCC, IC, R&TTE and TELEC	
Part Number	cB-ACC-57	
Name	InSide-2400	

Manufacture	ProAnt	
Gain	+3.0 dBi	
Size	27 x 12 mm (triangular)	
Cable length	100 mm	
Connector	U.FL. connector	
Comment	To be mounted on the U.FL connector on the PCB.	
Approval	FCC, IC, R&TTE and TELEC	

Part Number	cB-ACC-66	
Name	FlatWhip-2400	
Manufacture	ProAnt	
Gain	+3.0 dBi	
Size	Ø 50.0 x 30.0 mm	
Connector	SMA plug (inner thread and pin)	
Comment	To be mounted on the U.FL to SMA adapter cable.	
Approval	R&TTEand TELEC	

Part Number	cB-ACC-67	
--------------------	------------------	--

Name	Outside-2400	
Manufacture	ProAnt	
Gain	+3.0 dBi	
Size	36.0 x 18.0 x 16.0 mm	
Cable length	70 mm	
Connector	U.FL. connector	
Comment	To be mounted on the U.FL connector on the PCB.	
Approval	FCC, IC, R&TTE and TELEC	

5.2.3 Alternative antennas

The alternative antennas are available for backward compability but not recommended for new designs.

Part Number	cB-ACC-16 / cB-ACC-36	
Name	WCR2400-SMA / WCR2400-SMRP	
Manufacture	Laird Technologies / Centurion	
Polarization	Vertical	
Gain	+2.0 dBi	
Size	100 mm (Straight)	
Connector	cB-ACC-16: SMA plug (inner thread and pin) cB-ACC-36: Reverse Polarity SMA plug (inner thread and pin receptacle)	
Comment	cB-ACC-16 is to be used together with the U.FL to SMA adapter cable (cB-ACC-18 or cB-ACC-48). cB-ACC-36 is to be used together with the U.FL to Reverse Polarity SMA adapter cable (cB-ACC-38).	
Approval	cB-ACC-36: FCC, IC, R&TTE and TELEC cB-ACC-16: R&TTE and TELEC	
Part Number	cB-ACC-27 / cB-ACC-29	

Name	WCR-2400-IP04 / WCR-2400-IP10	
Manufacture	Laird Technologies / Centurion	
Polarization	Vertical	
Gain	+2.0 dBi	
Size	108 mm (Straight)	
Cable length	cB-ACC-27: 100 mm cB-ACC-29: 250 mm	
Connector	U.FL. connector	
Comment	To be mounted on the U.FL connector on the PCB.	
Approval	FCC, IC, R&TTE and TELEC	

Part Number	cB-ACC-23	
Name	PSTG0-2400HS	
Manufacture	Mobile Mark Communications Antennas	
Polarization	Vertical	
Gain	0 dBi	
Size	Ø 9.5 x 26 mm	
Connector	SMA plug (inner thread and pin)	

Comment	To be used together with the U.FL to SMA adapter cable (cB-ACC-18 or cB-ACC-48). An alternative Reverse Polarity SMA version antenna is available (PSTG0-2400HRS).	
Approval	R&TTEand TELEC	

Part Number	cB-ACC-28	
Name	NanoBlue-IP04	
Manufacture	Laird	
Polarization	Linear	
Gain	+2.0 dBi	
Size	47.8 x 12.7 x 0.9 mm	
Cable length	100 mm	
Connector	U.FL. connector	
Comment	To be mounted on the U.FL connector on the PCB.	
Approval	FCC, IC, R&TTE and TELEC	

Part Number	cB-ACC-17 / cB-ACC-37	
--------------------	------------------------------	--

Name	Reel planTec Bluetooth m70	
Manufacture	REEL	
Gain	+1.0 dBi	
Size	Ø 75 x 20 mm	
Mounting	M16 x 13.6 mm	
Connector	cB-ACC-17: SMA plug (inner thread and pin) cB-ACC-37: Reverse Polarity SMA plug (inner thread and pin receptacle)	
Cable length	300 cm. Other cable lengths are available on request.	
Comment	cB-ACC-17 is to be used together with the U.FL to SMA adapter cable (cB-ACC-18 or cB-ACC-48). cB-ACC-37 is to be used together with the U.FL to Reverse Polarity SMA adapter cable (cB-ACC-38).	
Approval	cB-ACC-37: FCC, IC, R&TTE and TELEC. cB-ACC-17: R&TTE.and TELEC	
Part Number	cB-ACC-21	

Name	R380.500.127	
Manufacture	Pulse	
Polarization	Vertical	
Gain	+2.0 dBi	
Size	Ø 14.3 x 61.4 mm	
Connector	SMA plug (inner thread and pin)	
Comment	To be mounted on the U.FL to SMA adapter cable (cB-ACC-18 or cB-ACC-48). A Reverse Polarity SMA version is also available (R380.500.125).	
Approval	R&TTEand TELEC	

Part Number	—	
Name	R380.500.139	
Manufacture	Pulse	
Polarization	Vertical	

Gain	+2.0 dBi	
Size	Ø 14.3 x 61.1 mm	
Connector	Reverse Polarity SMA plug (inner thread and pin receptacle)	
Comment	The difference compared to the R380.500.125 antenna is that the R380.500.139 antenna has a seal ring. To be mounted on the U.FL to Reverse Polarity SMA adapter cable (cB-ACC-38). An SMA version antenna is also available (R380.500.124).	
Approval	FCC, IC, R&TTE and TELEC	

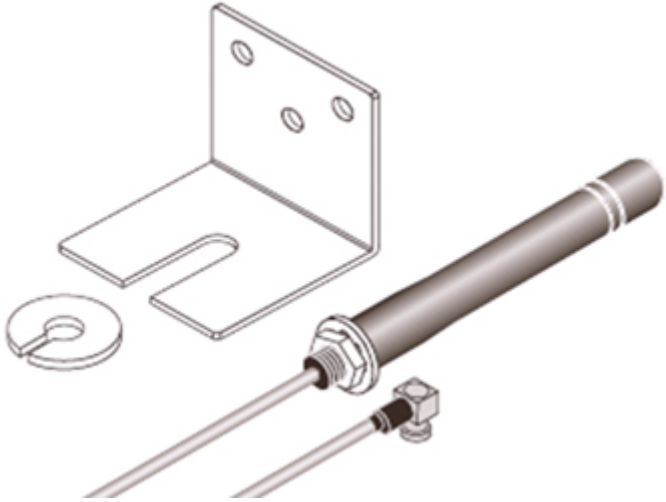
Part Number	—	
Name	IHF-242	
Manufacture	Joymax	
Polarization	Vertical	
Gain	+2.0 dBi	
Size	Ø 9.2 x 82.5 mm	
Cable length	150 cm	
Connector	MCX male connector	
Comment	To be mounted on a MCX to U.FL adapter cable.	
Approval	FCC, IC, R&TTE and TELEC	

6 Mechanics

6.1 Module Outlines

6.1.1 Dimensions

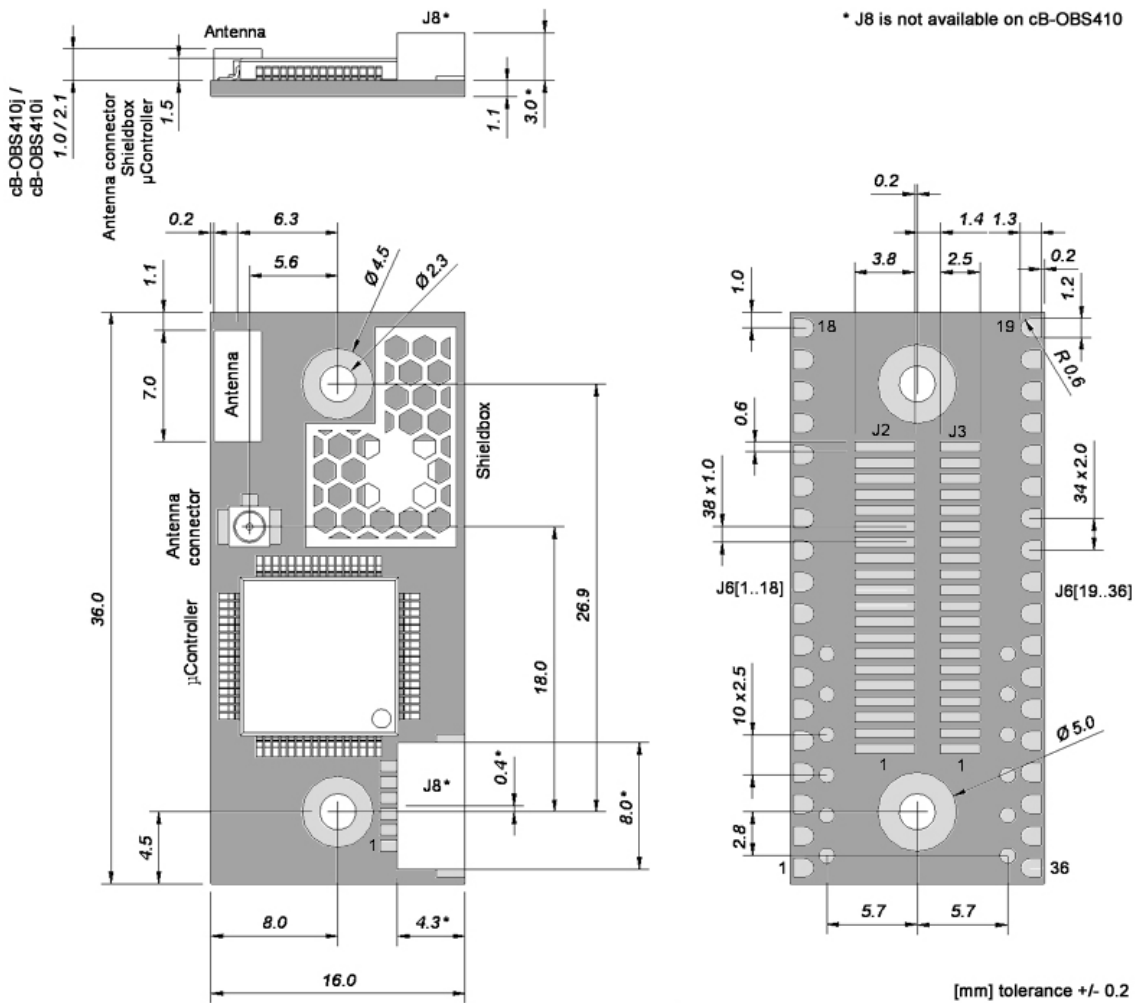

Figure 5: cB-OBS410 dimensions.

The J2 pads are longer to fit both the single and double row ASP connectors (see section [Using the J2/J3 Board-to-Board Connectors](#)).

Weight: 2 g

6.1.2 Mounting Holes

There are 2 x 2.3mm mounting holes on the cB-OBS410 module. The reasons for the 2.3mm holes are that the threaded M2 holes on the single and double row connectors (see section [Suitable One-Piece Part Connectors](#)) are not aligned. The outer tangents of the 2.3mm holes align the module if the single row connectors are used and the inner if double row connectors are used (see Figure 6).

Choose the outer tangent (CC distance 27.24mm) if the module is aligned and mounted with some other technique based on M2 screws (e.g. press-fit nuts), see Figure 7 and Figure 8.

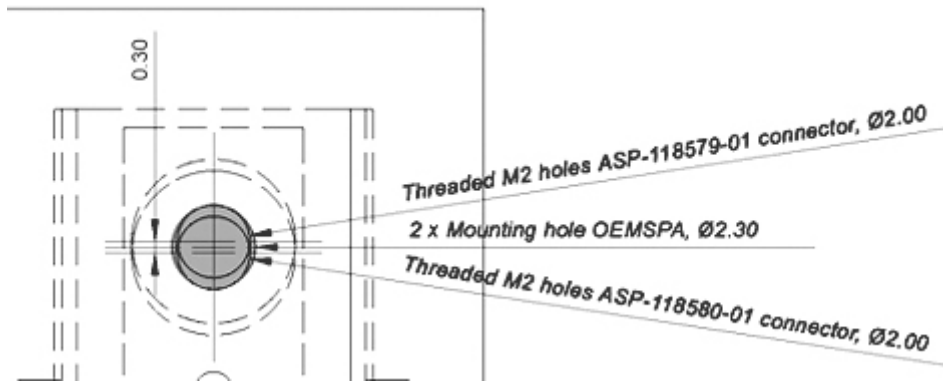

Figure 6: The 2.3mm mounting holes [mm].

6.2 Using the J2/J3 Board-to-Board Connectors

The board-to-board connector should be a 1mm pitch one-piece part connector. The recommended manufacture is [Samtec](#) with many connector options available; see section [Single row connectors](#) and [Double row connectors](#).

The [Electrical Interface and Connectors](#) section contains more information about the connector and the electrical interface.

6.2.1 Single row connectors

The single row connector SEI-120-02 can be used if only J2 is needed.

This connector has a profile height of 1.65 mm and this has to be considered if components are to be mounted on the motherboard under the OEM Serial Port Adapter board.

There are alignment pins on the bottom side of the connector.

The connector is available with M2 threaded inserts that fit the mounting holes on the board (see section [Suitable One-Piece Part Connectors](#)). You may screw the OEM Serial Port Adapter board directly into these inserts.

If you want to have a tighter and more secure mounting, you may use longer screws and secure it using a nut on the backside of the motherboard.

Another way to mount the module is to use press-fit nuts on the motherboard and skip the M2 threads on the connector, see section [Using Press-Fit Nuts for Mounting the Module](#) for more information about press-fit nuts.

Table 8: Single row connectors from Samtec.

Samtec order number	Quote number	Equivalent part	Package	Remark
ASP-118645-01	55392	SEI-120-02-GF-S-AB	Tube	Align pin on bottom side only
ASP-118645-02	55392	SEI-120-02-GF-S-AB-TR	Tape-n-Reel	Align pin on bottom side only
ASP-118579-01	55392	SEI-120-02-GF-S-M-AB	Tube	With M2 threaded inserts and align pin on bottom side only
ASP-118579-02	55392	SEI-120-02-GF-S-M-AB-TR	Tape-n-Reel	With M2 threaded inserts and align pin on bottom side only

NOTE

When ordering connectors from Samtec or an official Samtec distributor, please use the ASP order number and refer to the connectBlue global quote number for best price. For technical questions regarding the Samtec connectors please contact connectBlue or Samtec at (Scandinavia@samtec.com).

See Figure 7 for more information about the connector and necessary measurements on the motherboard. The large mounting holes on the motherboard are designed for press-fit nuts and could be smaller if press-fit nuts are not used. The mounting holes are aligned with the outer tangent of the 2.3mm mounting holes of the module (see section [Mounting Holes](#)).

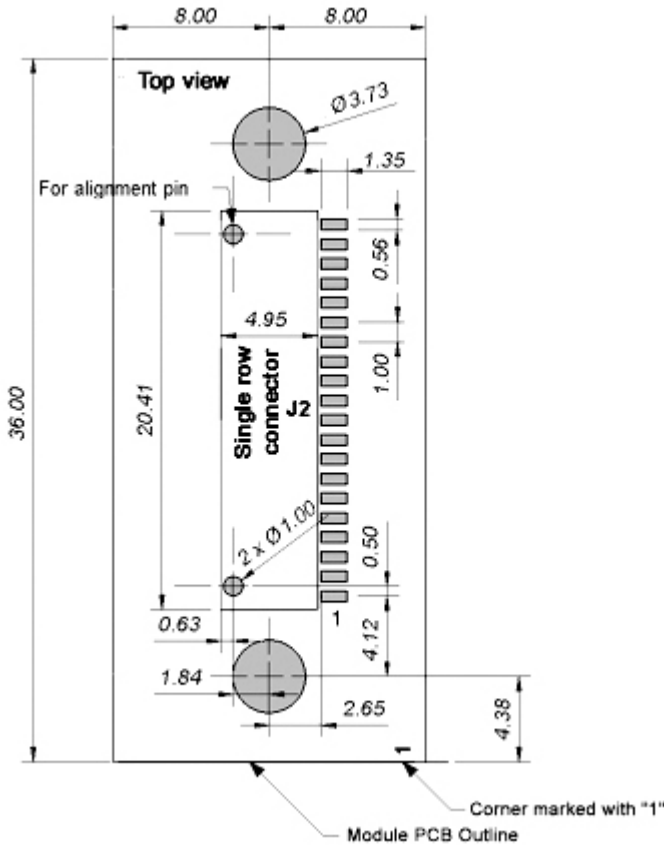

Figure 7: Host PCB layout [mm] for single row connector.

6.2.2 Double row connectors

This connector is a double row connector and can be used if both J2 and J3 are needed. This connector has a height of 3.0mm and this has to be considered if components are to be mounted on the motherboard under the OEM Serial Port Adapter board. The connector is also available with a height of 6.0mm and 10.0mm (The FSI-120 series from [Samtec](#)). There are alignment pins on the bottom side of the connector. The connector is available with M2 threaded inserts that fit the mounting holes on the board (see section [Mounting Holes](#)). You may screw the OEM Serial Port Adapter board directly into these inserts. If you want to have a tighter and more secure mounting you may use longer screws and secure it using a nut on the backside of the motherboard. Another way to mount the module is to use press-fit nuts on the motherboard and skip the M2 threads on the connector, see section [Using Press-Fit Nuts for Mounting the Module](#) for more information about press-fit nuts.

Table 9: Double row connectors from Samtec.

Samtec order number	Quote number	Equivalent part	Package	Remark
REF-120021-01	55392	FSI-120-03-G-D-AB	Tube	Align pin on bottom side only
REF-120021-02	55392	FSI-120-03-G-D-AB-K-TR	Tape-n-Reel	Align pin on bottom side only
REF-120018-01	55392	FSI-120-03-G-D-M-AB	Tube	With M2 threaded inserts and align pin on bottom side only
REF-120018-02	55392	FSI-120-03-G-D-M-AB-K-TR	Tape-n-Reel	With M2 threaded inserts and align pin on bottom side only

NOTE

When ordering connectors from Samtec or an official Samtec distributor, please use the REF order number and refer to the connectBlue global quote number for best price. For technical questions regarding the Samtec connectors please contact connectBlue or Samtec at (Scandinavia@samtec.com).

See Figure 8 for more information about the connector and necessary measurements on the motherboard. The large mounting holes on the motherboard are designed for press-fit nuts and could be smaller if press-fit nuts are not used (see section [Mounting Holes](#)).

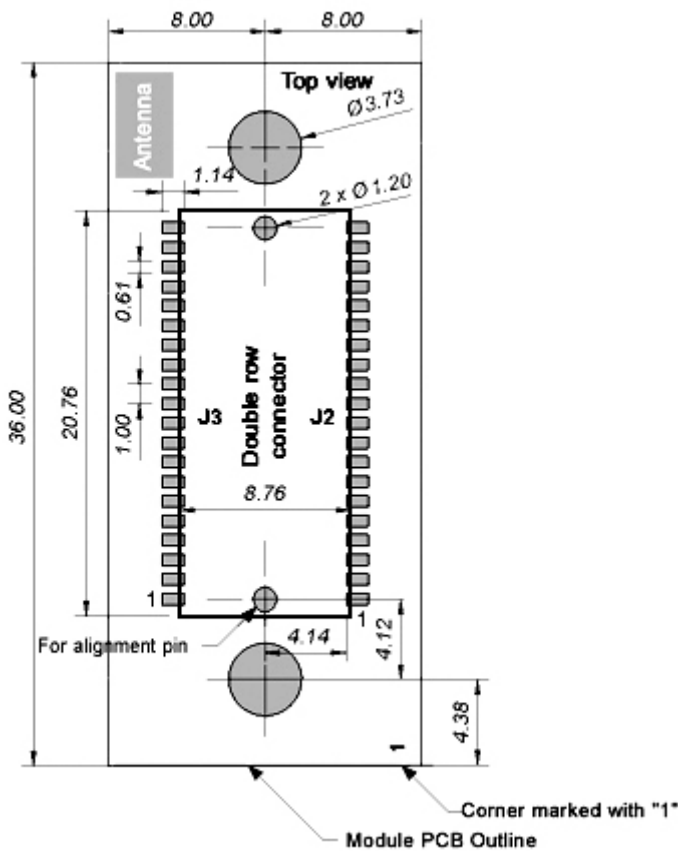

Figure 8: Host PCB layout [mm] for double row connector.

6.3 Using Press-Fit Nuts for Mounting the Module

A press-fit nut is pressed into the PCB from the bottom side with a special press tool. M2 sized press-fit nuts are suitable for the modules (see Figure 7 and Figure 8) and are manufactured by PEM Fastening Systems (www.pemnet.com), part no KFS2-M2 (see Figure 9). Be careful with the distance between the nuts regarding alignment, see the [Mounting Holes](#) section.

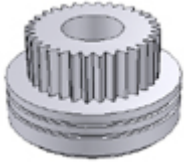

Figure 9: KFS2-M2 press-fit nut.

Spacer-pipes are recommended to use between the PCBs when press-fit nuts are used.

6.4 Using the J6 PCB solder pads

6.4.1 Host Board

The host PCB footprint should not contain any traces or vias under the module except the pads interfacing the J6 pads to avoid contact with traces/vias on the module. The host pads which are soldered to the J6 pads should match the J6 pads but could be extended 0.5-1.0mm outside the module for visual solder inspection. No other pads than the J6 should be soldered to the host PCB. See section [J2, J3 and J6 Connectors](#) for more info about the J6 pads.

6.4.2 Mounting process

We strongly recommend the modules not being soldered more than 1 time after shipping from connectBlue and that the modules are mounted just before the host product is being soldered the last time. Although, connectBlue devices will withstand up to two reflows to an absolute maximum temperature of 250°C.

- The PCB in our modules is made of FR4-type with Chemical Gold Pads.
- The modules are produced in a lead-free process with a lead-free soldering paste.
- It is recommended that the customers make their own electrical, climate, stress and vibration tests on the final assembled product to secure that the manufacturing process hasn't damaged or affected the Bluetooth module in any way.
- The modules are normally delivered without labels on each module when packaged on tape-and-reel. However, if they are delivered with labels on each module, the labels should be removed before the module is processed since the labels do not withstand the heat of soldering.
- The device recommended maximum re-flow temperature is 245°C for 10 sec.
- The device absolute maximum re-flow temperature is 250°C for 3 sec.

6.5 Antenna Issues

The unit cannot be mounted arbitrary, because of the radio communication. The unit with an internal surface mounted antenna (cB-OBS410i and cB-OBS410j) cannot be mounted in a metal enclosure. No metal casing or plastics using metal flakes should be used, avoid also metallic based paint or lacquer. Keep a minimum clearance of 5 mm between the antenna and the casing. Keep minimum 10 mm free space from metal around the antenna including under and above. If a metal enclosure is required, one of the external antenna options has to be used. See [Surface Mounted Antenna \(Internal\)](#) for more information on the antenna options available.

7 Bluetooth Information

7.1 General information

In the tables below you can find information about Bluetooth properties.

Table 10: Bluetooth information cB-OBS410

Parameter	Data
Bluetooth radio	ST-Ericsson STLC2500DB
Host micro controller	ST Microelectronics STM32F10x
RF output power (conducted - excluding antenna gain)	Class 1, max 4dBm + antenna gain (See Antennas)
Receive sensitive level	-84dBm - antenna gain (See Antennas)
Receive input level (max)	+15dBm
Output frequency	2.402 - 2.480 GHz, ISM band.
Bluetooth stack	connectBlue Embedded Bluetooth Stack
Bluetooth qualification	2.1+EDR

7.2 Bluetooth Qualification information



All products based on the PCB cB-0925 have been qualified according to the Bluetooth specification 2.1+EDR.

For information how to List and Declare your product see the [Bluetooth Qualification Guide](#).

The following Bluetooth profiles are supported (covered functionality):

- Generic Access Profile (GAP)
- Serial Port Profile (SPP)
- Dial-up Networking Profile (DUN GW, DUN DT)

The Bluetooth SIG's "Go To Market Toolkit" guides you through four key steps for success when going to market with a Bluetooth enabled product: <https://www.bluetooth.org/en-us/bluetooth-brand/go-to-market-toolkit>

8 Regulatory Information

8.1 Declaration of Conformity

CE 0678

We, **connectBlue AB**, of **Norra Vallgatan 64 3V**
SE-211 22 Malmö, Sweden

declare under our sole responsibility that our products:

cB-OBS410 (cB-0925-01), OEM Module Adapter III (cB-0068).

to which this declaration relates, conforms to the following product specifications:

R&TTE Directive 1999/5/EC:

Effective use of frequency spectrum:

EN 300 328 V1.7.1 (2006-10)

EMC:

EN 301 489-1 V1.9.2 (2011-09)

EN 301 489-17 V2.2.1 (2012-09)

EN 61000-6-2 (2005)

Health and safety:

EN 62479:2010

EN 60950-1:2006 + A11:2009 + A1:2010 + A12:2011

IEC 60950-1:2005 + A1:2009

Medical Electrical Equipment

IEC 60601-1-2 (2007)

2014-04-09 Malmö, Sweden

Mats Andersson

CTO of connectBlue AB

8.2 Safety Compliance

In order to fulfill the safety standard EN 60950-1 the unit must be supplied by a limited power source.

8.3 FCC and IC Compliance

See the [Product Variants](#) section for information about the different product variants.

8.3.1 Compliance for cB-0925

8.3.1.1 FCC Statement for cB-0925

This device complies with Part 15 of the FCC Rules. Operation is subject to the following two conditions:

- (1) this device may not cause harmful interference, and
- (2) this device must accept any interference received, including interference that may cause undesired operation.

NOTE

This equipment has been tested and found to comply with the limits for a Class B digital device, pursuant to Part 15 of the FCC Rules. These limits are designed to provide reasonable protection against harmful interference in a residential installation. This equipment generates, uses and can radiate radio frequency energy and, if not installed and used in accordance with the instructions, may cause harmful interference to radio communications. However, there is no guarantee that interference will not occur in a particular installation. If this equipment does cause harmful interference to radio or television reception, which can be determined by turning the equipment off and on, the user is encouraged to try to correct the interference by one or more of the following measures:

- Reorient or relocate the receiving antenna
- Increase the separation between the equipment and receiver
- Connect the equipment into an outlet on a circuit different from that to which the receiver is connected

Consult the dealer or an experienced radio/TV technician for help.

8.3.1.2 Caution

Any changes or modifications NOT explicitly APPROVED by connectBlue AB could cause the module to cease to comply with FCC rules part 15, and thus void the user's authority to operate the equipment.

8.3.1.3 IC Compliance

Operation is subject to the following two conditions:

- (1) this device may not cause harmful interference, and
- (2) this device must accept any interference received,

including interference that may cause undesired operation.

This device has been designed to operate with an antenna having a maximum gain of 8.0 dBi. Having a higher gain is strictly prohibited per regulations of Industry Canada. The required antenna impedance is 50 ohms.

To reduce potential radio interference to other users, the antenna type and its gain should be so chosen that the equivalent isotropically radiated power (EIRP) is not more than that required for successful communication.

The installer of this radio equipment must ensure that the antenna is located or pointed such that it does not

emit RF field in excess of Health Canada limits for the general population; consult Safety Code 6, obtainable from Health Canada's website www.hc-sc.gc.ca/rpb

8.3.1.4 Labeling Requirements for End Product

For an end product using the product cB-0925 there must be a label containing, at least, the following information:

This device contains
FCC ID: PVH0925
IC: 5325A-0925

The label must be affixed on an exterior surface of the end product such that it will be visible upon inspection in compliance with the modular approval guidelines developed by the FCC.

In accordance with 47 CFR § 15.19 the end product shall bear the following statement in a conspicuous location on the device:

"This device complies with Part 15 of the FCC Rules.
Operation is subject to the following two conditions;

- (1) this device may not cause harmful interference, and
- (2) this device must accept any interference received, including interference that may cause undesired operation."

When the device is so small or for such use that it is not practicable to place the statement above on it, the information shall be placed in a prominent location in the instruction manual or pamphlet supplied to the user or, alternatively, shall be placed on the container in which the device is marketed. However, the FCC ID label must be displayed on the device.

In case, where the final product will be installed in locations where the end-user is not able to see the FCC ID and/or this statement, the FCC ID and the statement shall also be included in the end-product manual.

8.4 UL listing information

If a customer intends to UL list a product including any of the Bluetooth modules based on the PCB cB-0925 this information is useful:

The printed circuit board if produced according to the following specification:

- UL recognized ZPMV2 min. 105 °C flame class V-0 or better.

8.5 Japan Radio Equipment Compliance (TELEC)

The cB-0925 module with the product name cB-OBS410 complies with the Japanese Technical Regulation Conformity Certification of Specified Radio Equipment (ordinance of MPT N°. 37, 1981), Article 2, Paragraph 1, Item 19, "**2.4GHz band wide band low power data communication system**". The cB-OBS410 MIC certification number is 204WW11100500.

When a product is placed on the Japanese market, the cB-OBS410 module product must be affixed with the following Specified Radio Equipment marking:



The minimum size of the logo is Ø3.0mm. The end product holder should also include a copy of the Japan Radio Certificate to the end product technical documentation, contact [connectBlue](#) for a copy of the Radio Certificate. Module labels with the above marking may be ordered via the connectBlue distributors using the order code cB-ACC-70.

The end product is recommended to be marked with:

"Contains MIC ID:  204WW11100500"

8.6 Compliance with RoHS directive



All products based on the PCB cB-0925 are produced according to the RoHS (Restriction of the use of certain Hazardous substances in electrical and electronic equipment) directive and complies with the directive.

9 Guidelines for Efficient and Safe Use

9.1 General

Read this information before using your OEM Serial Port Adapter.

For any exceptions, due to national requirements or limitations, when using your OEM Serial Port Adapter, please visit www.bluetooth.org.

 **NOTE**

Changes or modifications to the product not expressly approved by connectBlue AB will void the user's authority to operate the equipment.

9.2 Product Care

- Do not expose your product to liquid or moisture.
- Do not expose your product to extreme hot or cold temperature (see section [Environmental](#) for further information).
- Do not expose your product to lit candles, cigarettes, cigars, open flames, etc.
- Do not drop, throw or try to bend your product since rough treatment could damage your product.
- Do not attempt to disassemble your product. Doing so will void warranty. The product does not contain consumer serviceable or replaceable components. Service should only be performed by connectBlue AB.
- Do not paint your product as the paint could prevent normal use.
- If you will not be using your product for a while, store it in a place that is dry, free from damp, dust and extreme heat and cold.
- The clearance and creepage distances required by the end product must be withheld when the module is installed.
- The cooling of the end product shall not negatively be influenced by the installation of the module when the module is installed.

9.3 Radio Frequency Exposure

The OEM Serial Port Adapter contains a small radio transmitter and receiver. During communication with other Bluetooth products the OEM Serial Port Adapter receives and transmits radio frequency (RF) electromagnetic fields (microwaves) in the frequency range 2400 to 2500 MHz. The output power of the radio transmitter is less than 4mW.

When using the OEM Serial Port Adapter, you will be exposed to some of the transmitted RF energy. This exposure is well below the prescribed limits in all national and international RF safety standards and regulations.

9.4 Electronic Equipment

Most modern electronic equipment, for example, in hospitals and cars, is shielded from RF energy. However, certain electronic equipment is not. Therefore:

⚠ NOTE

This equipment emits RF energy in the ISM (Industrial, Scientific, Medical) band. Please insure that all medical devices used in proximity to this device meet appropriate susceptibility specifications for this type of RF energy.

9.5 Potentially Explosive Atmospheres

Turn off your electronic device before entering an area with potentially explosive atmosphere. It is rare, but your electronic device could generate sparks. Sparks in such areas could cause an explosion or fire resulting in bodily injury or even death.

Areas with a potentially explosive atmosphere are often, but not always, clearly marked. They include fuelling areas, such as petrol station, below deck on boats, fuel or chemical transfer or storage facilities, and areas where the air contains chemicals or particles, such as grain, dust, or metal powders.

9.6 Power Supply

The OEM Serial Port Adapter must be supplied by a limited power source according to EN 60950-1.

- Connect your power supply only to designated power-sources as marked on the product.
- Make sure all cords and cable are positioned so that they will not be stepped on, tripped over or otherwise subject to damage or stress.
- To reduce risk of electric shock, unplug the unit from any power source before attempting to clean it.

10 Application Notes

Usually only a subset of the available functionality is of interest to the designer. In addition, depending on the host system, the electrical interface can be designed in many ways. The designer can use the step-by-step guide in this chapter as an aid in the design process.

10.1 Step-by-Step Guide

Table 12: Step-by-step guide with Yes and No answers.

Question	Yes	No
Are you going to integrate the OEM Serial Port Adapter in a metal enclosure?	Use one of the OEM Serial Ports Adapters with antenna connector for external antenna (cB-OBS410x).	Go on to next point.
Do you wish to use logic level when communicating with the OEM Serial Port Adapter?	See section Logic level Mode for electrical design.	See section External RS232 driver and External RS422 driver for electrical design.
Do you want to use RS232 as the physical serial interface?	See section External RS232 driver for electrical design.	Go on to next point.
Do you wish to connect LEDs to the OEM Serial Port Adapter?	See section LED and Switch Design for design examples for connecting the LEDs.	Go on to next point.
Do you want to detect the status of the module with a controller?	See section Operating Status for status detection and section LED and Switch Design for electrical design.	Go on to next point.
Do you wish to utilize the restore switch?	See section GREEN/Switch-1 for electrical design.	Go on to next point.
Do you wish to utilize the Function switch ("Connect on external signal")?	See section Switch-0 Signal for electrical design.	Go on to next point.
Do you want to manually reset the module?	See section Reset for electrical design. Use a double row connector. See section Double row connectors .	

10.2 Design Examples

This section contains design examples for all interfaces on J2, J3, and J6. The connector type that suits a specific application depends on the needed signal and the preferred interface type (board-to-board or SMD).

10.2.1 Logic Levels

10.2.1.1 3.0/3.3 voltage host system

A 3.0/3.3V host system can be connected directly to the logic level pins (BLUE, UART-TxD / UART-RxD etc). A serial 100Ohm resistor shall be used (see Figure 10) for protection, see the [Characteristics](#) section for logic levels characteristics.

10.2.1.2 5 voltage host system

A 5V host system can easily be adjusted to the logic levels.

10.2.1.2.1 Module input signals in a 5V host system

The module input signals can use a resistive divider (1.8kOhm/2.2kOhm) to adjust the levels (See Figure 10). This is applicable for speeds up to 115.2kBits/s. The divider can be improved by adding a logic buffer (74HCT08) for higher speeds (see Figure 11). The resistor dividers consume current and a better solution could be to use the 5V input tolerant gates in the LVC family. The LVC gates are available in single, dual and quad gates packages (e.g. 74LVC1G08, 74LVC2G08 and 74LVC08). The LVC gates need to be power supplied with the module signal voltage levels (see [Input/Output signals](#)). The VCC_2V85 pin (see the [Pin Description](#) section) can be used for supplying the interface circuits. Notice that the VCC_2V85 output voltage supply not is available on all connectBlue modules e.g. if the application is designed to be used with different pin compatible connectBlue modules.

The LVC gates could maybe also be used for output signals if the host input signals are TTL compatible ($V_{IN_HIGH_MIN} = 2V$). LVC gate can not be used on 5V CMOS input signals.

10.2.1.2.2 Module output signals in a 5V host system

The module output pins could require a buffer (see Figure 11) depending on the logic level requirements (see the [Characteristics](#) section). HCT gates supplied with 5V can be used in a 5V host system with TTL or CMOS inputs (see Figure 11). LVC gates can maybe be used for output signals if the host input signals are TTL compatible ($V_{IN_HIGH_MIN} = 2V$). LVC gate can not be used on 5V CMOS host input signals.

The 74HCT08 gate is also available in a single and dual gate package (74AHCT1G08 and 74AHCT2G08).

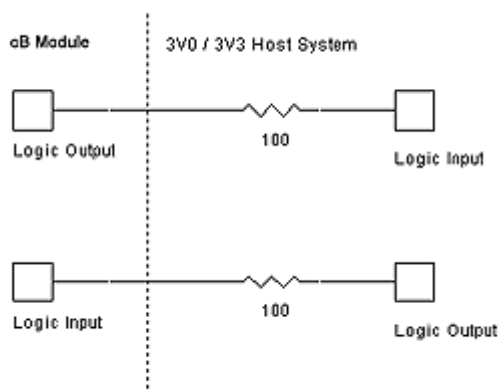

Figure 10: Logic levels interface to a 3/3.3V system. A protective 100Ohm resistor is used.

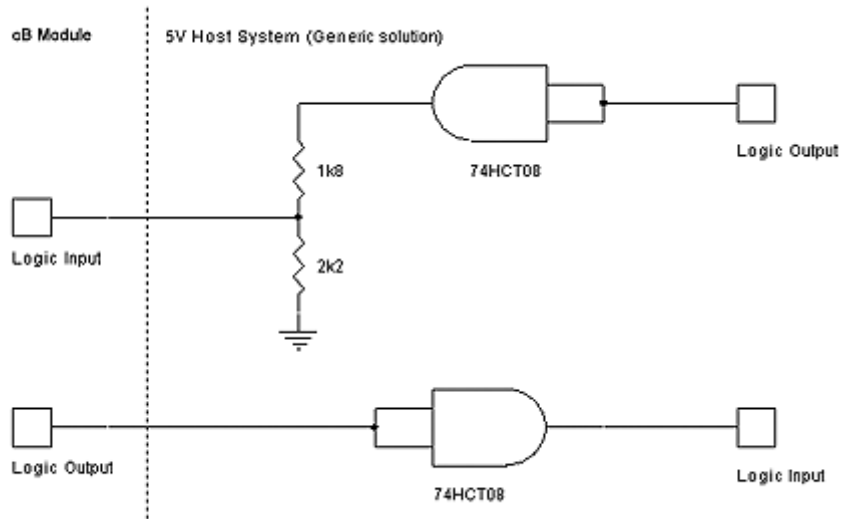
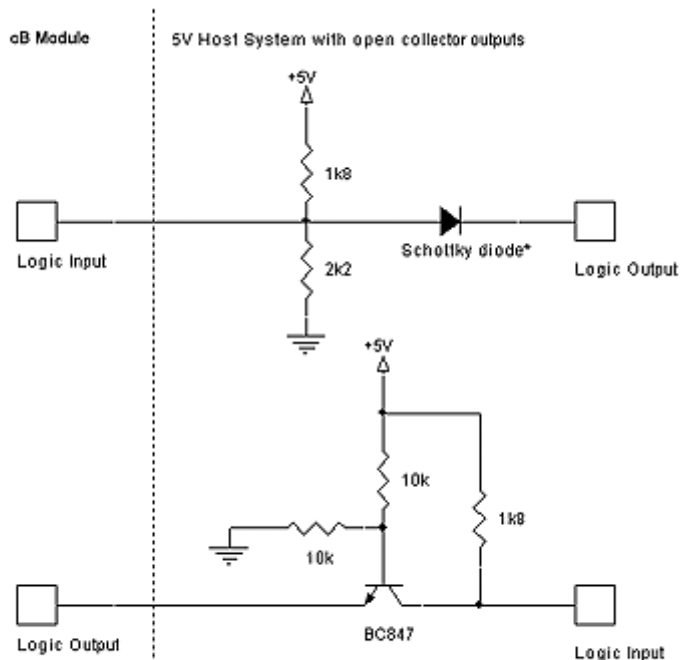

Figure 11: Interface example with logic levels to a 5V system. The gate converting from host 5V output to module input can be replaced with an LVC gate if the voltage divider is removed.

A 5V system with open collector outputs is designed in Figure 12.



* Recommended if the host controller are internally pulled-up

Figure 12: Open collector outputs.

10.2.2 Serial Interface

The serial interface of the module is Logic Level logic levels and the module can be connected to an external μ Controller (see section [Logic level Mode](#)).

An external driver is needed if the module should be on another physical interface like RS232 (see section [External RS232 driver](#) - [External RS422 driver](#)).

CTS (Clear To Send) and RTS (Request To Send) are used for hardware flow control.

DSR (Data Set Ready) can be used to make a connect attempt. See the Serial Port Adapter AT commands specification.

DTR (Data Terminal Ready) can be used to detect if the module is up and running and ready to receive data.

NOTE

The module must be configured to flow control none if hardware flow control is not used, see the Serial Port Adapter AT Commands specification.

10.2.2.1 Logic level Mode

The serial UART interface can be used in a host controller application with a UART interface. The design of the interface depends on the power supply voltage of the host system; see the [Logic Levels](#) section for voltage translation.

10.2.2.2 External RS232 driver

An external RS232 driver is needed if the module should have a RS232 serial interface. See Figure 13 for a complete design example that could be connected to the serial port of standard PC. Not used functionality can be left unconnected; see section [Serial Interface](#).

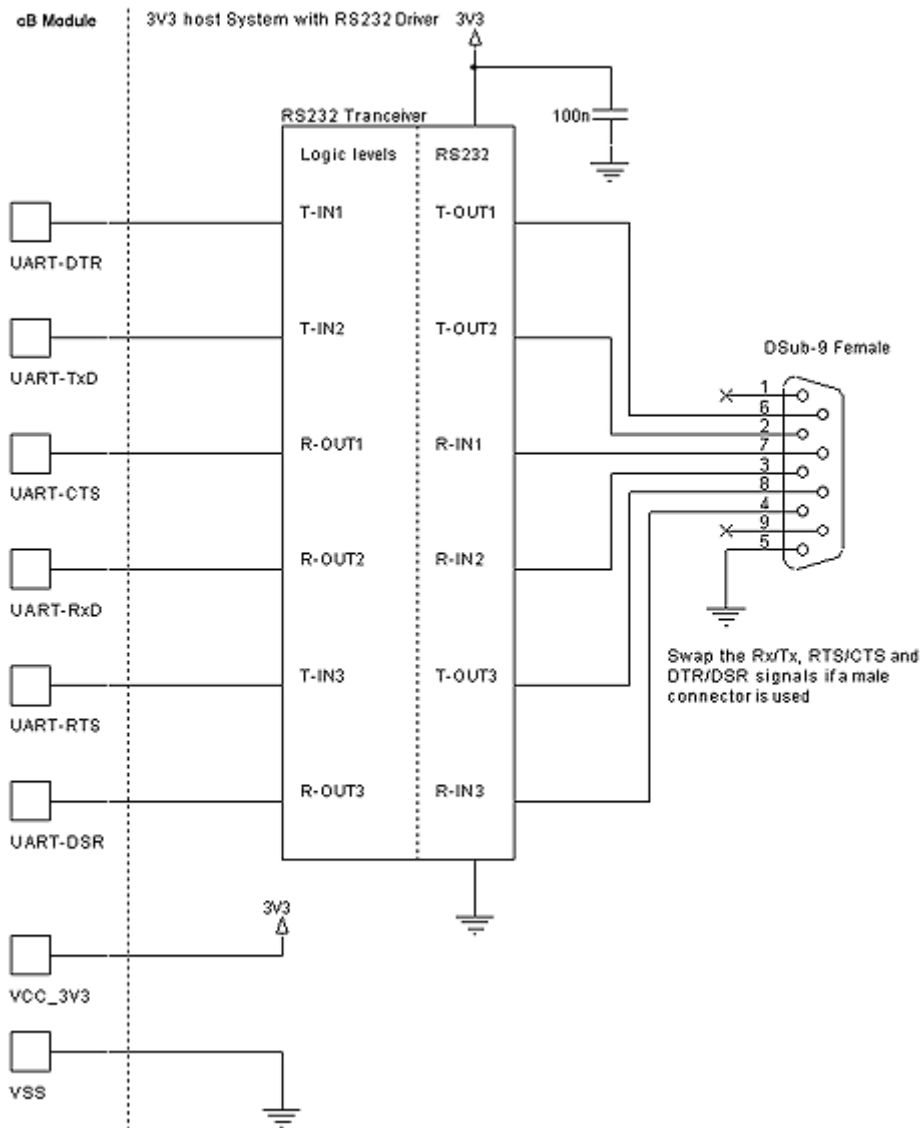

Figure 13: A complete RS232 interface.

10.2.2.3 External RS422 driver

An external RS422 driver could be used in a point-to-point (full duplex) application (see Figure 14).

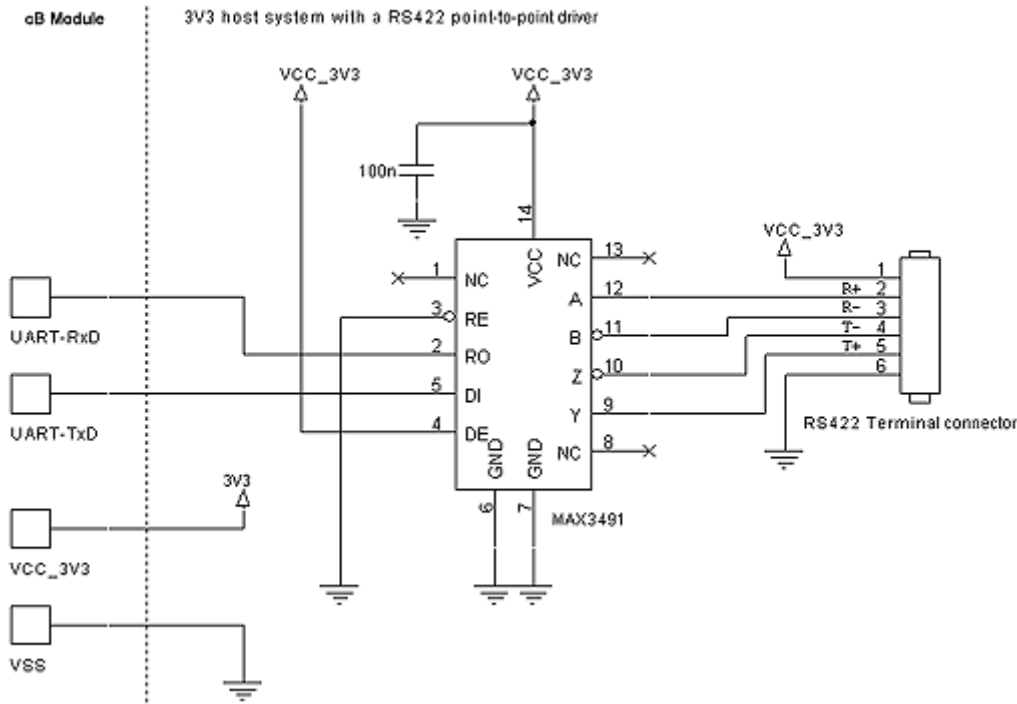

Figure 14: A complete RS422 interface.

10.2.2.4 External RS422/RS485 transceiver

A complete RS422/RS485 transceiver design connected to a bus system need to control the enable signals of the transceiver. The SerialSelect signals are used for this purpose (see Table 13). The module need to be software configured to the corrected interface, see the Serial Port Adapter AT Commands document how to configure the module to the correct serial interface. The Red/Mode pin is not allowed to be pull-down when using the SerialSelect signals (see the [Pin Description](#) section).

Table 13: SerialSelect signals combinations

SerialSelect -0	SerialSelect-1	RS485/RS422 Transmitter status (Active high)	RS485/RS422 Receiver status (Active low)
0	0	Disabled	Enabled
0	1	Enabled	Enabled
1	0	Enabled	Disabled
1	1	Disabled	Disabled

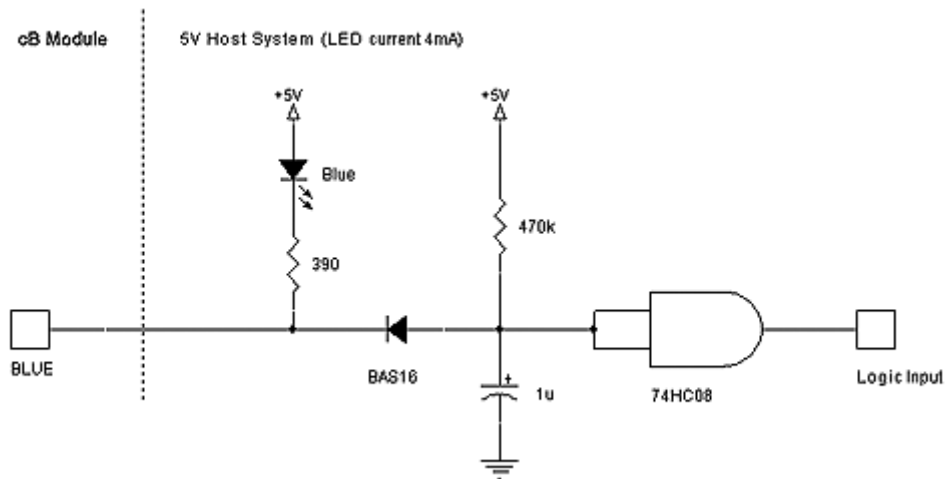

Figure 17: A Low pass filter and a 74HC08 suppresses the flashes when the module is sending and receiving data. The Blue LED can be removed if not required. The values are not suitable in all applications and need to be verified in a specific application.

10.2.3.2 RED/Mode Signal

The RED logic LED signal is not multiplexed with any other functionality. See Figure 18 for a 3.3V design. In a 5V system the high state output from the module is not enough to turn off the LED so a 74HCT08 buffer can be used to raise the high level to 5V (see Figure 19).

The 74HCT08 gate is available in a single and dual gates package (74AHCT1G08 and 74AHCT2G08).

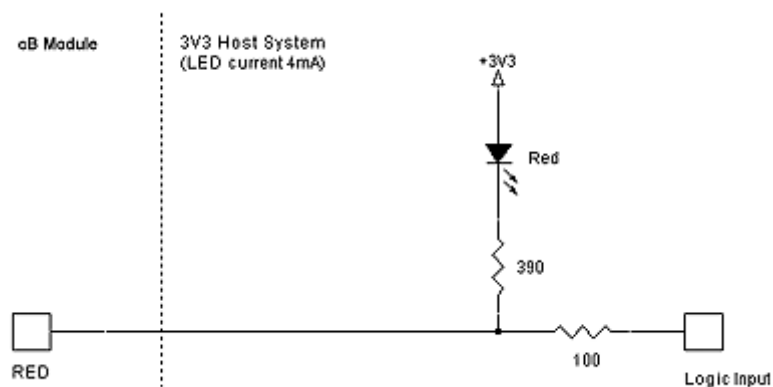

Figure 18: A red LED in a 3.3V host system. The status of the signal can also be used as input to a host controller.

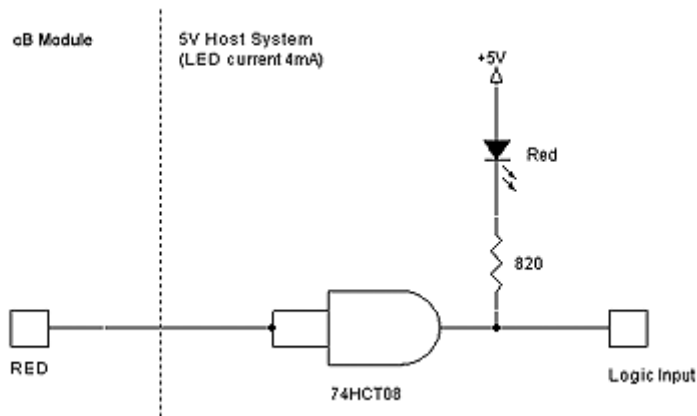

Figure 19: A red LED in a 5V host system. The status of the signal can also be used as input to a host controller.

The RED signal pin is also used to select Logic Level mode (instead of RS232) for connectBlue product with internal RS232 driver e.g. cB-OEMSPA312. The mode functionality is not applicable on cB-OBS410 because there is no internal RS232 driver available. To be compatible with these products check this signal in their Electrical and Mechanical datasheet.

10.2.3.3 GREEN/Switch-1 signal

The GREEN/Switch-1 signal is a multiplexed signal:

- **GREEN** - Logic green LED signal (see the [Operating status](#) section). Becomes valid after the module has started up. The startup time can be up to 2 seconds (see the Serial Port Adapter AT Commands specification).
- **Switch-1** - The module reads the status of the signal at startup to decide if the serial interface settings shall be restored (LOW). The module will restore all factory settings if both the Switch-1 and Switch-0 signals are low during start up. See the Serial Port Adapter AT Commands specification for more details. The input signal must be stable for the first 500ms after startup (after reset/power on reset).

The signal is internally pulled-up (see [Input/Output signals](#)) to the internal voltage supply (see [Power supply](#)) for NOT restoring settings to default values.

NOTE

The internal pull-up is changed compared to previous product generations from connectBlue. See the [Migrating from Bluetooth cB-OEMSPA3xx to cB-OBS4xx products](#) section for more information.

If a LED is used and a switch is required to be able to restore the settings, a high impedance buffer need to prevent the signal from being pulled-up via the LED. See Figure 20-21 and the [Logic Levels](#) section for buffer selection.

Sometimes, over time, switch contacts can get an oxide layer. This may cause the closed switch resistance to become too high to sink the signal to logic LOW because the signal is internally pulled-up (see [Input/Output signals](#)). A design that prevents this can be found in Figure 25.

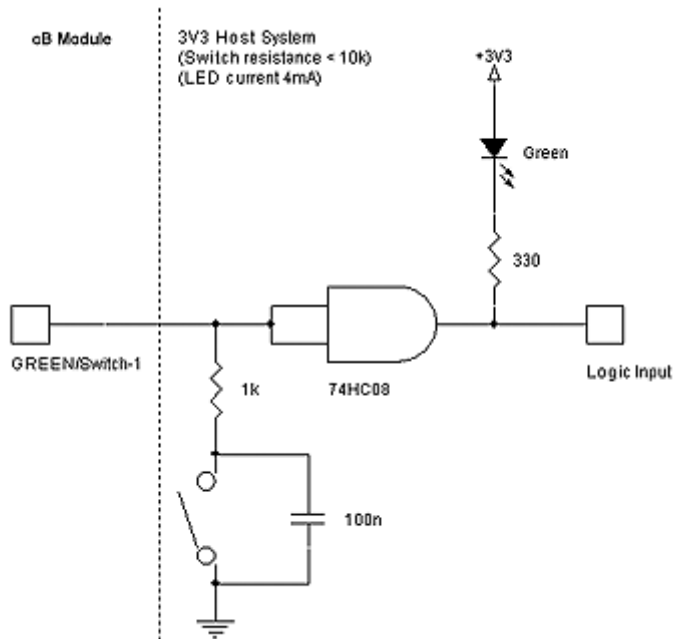

Figure 20: Switch-1 used together with a green LED in a 3.3V host system. The status of the signal can also be used as input to a host controller. Notice the 1kOhm serial resistor.

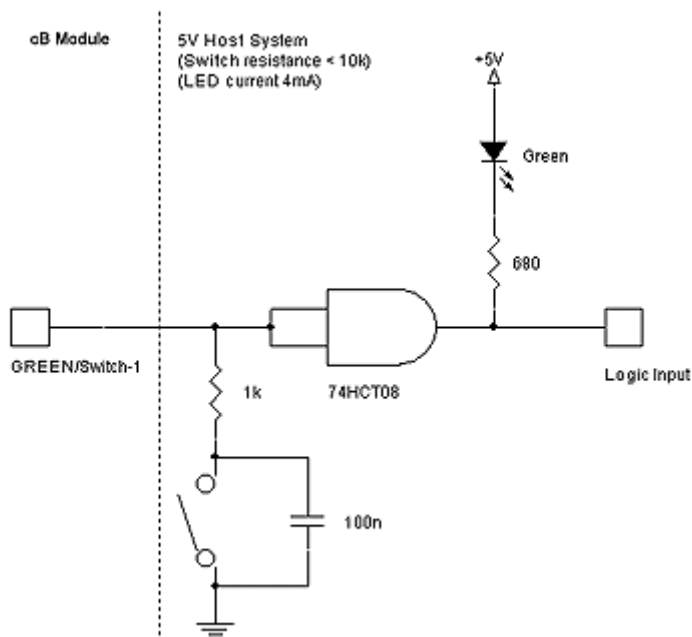

Figure 21: Switch-1 used together with a green LED in a 5V host system. The status of the signal can also be used as input to a host controller. Notice the 1kOhm serial resistor.

The buffer can be removed in a 3.3V system if no restore switch is required (see Figure 22).

In a 5V system the high state output from the module is not enough to turn off the LED, so a 74HCT08 buffer can be used to raise the high level to 5V (see Figure 23).

The 74HCT08 gate is also available in a single gate package (74AHCT1G08).

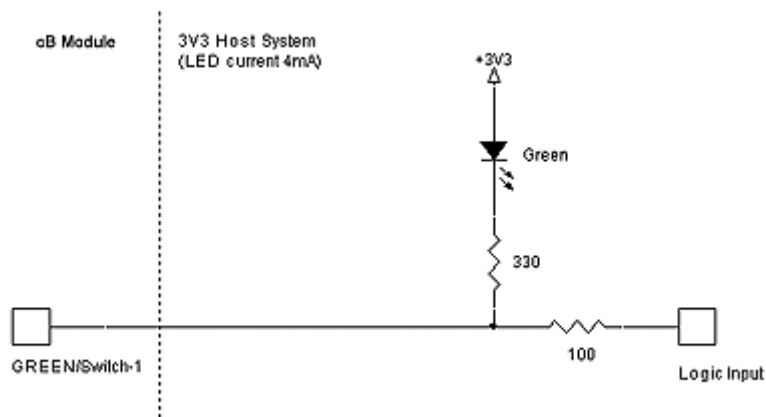

Figure 22: No restore switch used but a green LED in a 3.3V host system. The status of the signal can also be used as input to a host controller.

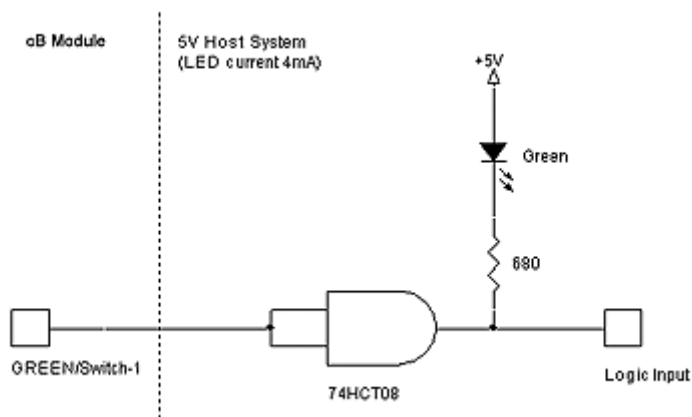

Figure 23: No restore switch used but a green LED in a 5V host system. The status of the signal can also be used as input to a host controller.

A serial resistor to the restore switch must be used to prevent a short circuit when the GREEN/Switch-1 pin is in output HIGH state and the switch is pressed (see Figure 24).

Sometimes, over time, switch contacts can get an oxide layer. This may cause the closed switch resistance to become too high to sink the signal to logic LOW because the signal is internally pulled-up (see [Input/Output signals](#)). A design that prevents this can be found in Figure 25. The GREEN/Switch-1 pin can be left unconnected if none of its functionality is required.

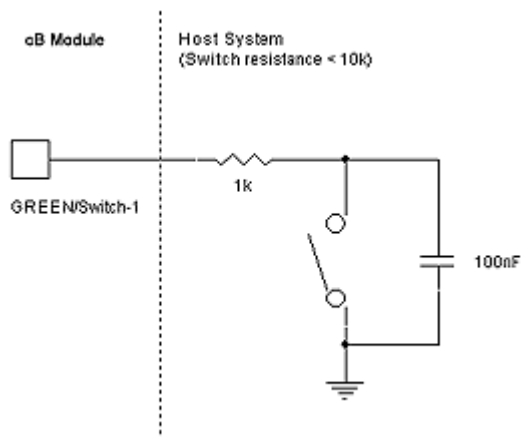

Figure 24: A low resistance restore switch used. Notice the 1kOhm serial resistor.

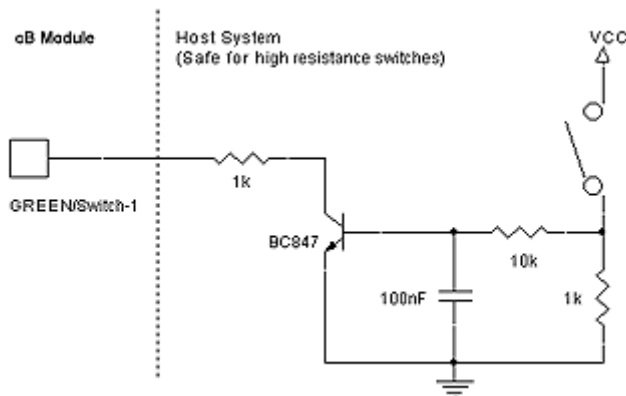

Figure 25: If the resistance in the switch is not guaranteed to be low enough, a safer design can be used. Notice the 1kOhm serial resistor.

10.2.3.4 Switch-0 Signal

Switch-0 is used for the external connect function. A secondary function is that the module will restore all factory settings if both the Switch-1 and Switch-0 signals are low during start up. See the Serial Port Adapter AT Commands specification for more details.

Sometimes, over time, switch contacts can get an oxide layer. This may cause the closed switch resistance to become too high to sink the signal to logic LOW because the signal is internally pulled-up (see [Input/Output signals](#)). A design that prevents this can be found in Figure 27.

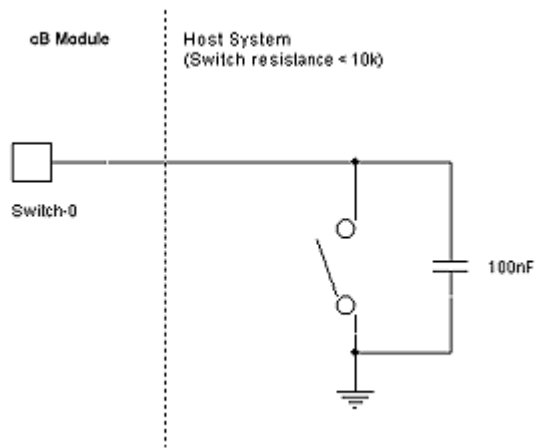

Figure 26: A low resistance function switch used.

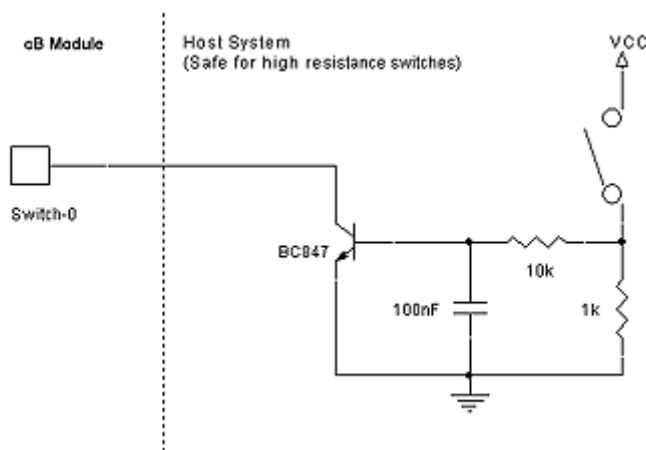

Figure 27: If the resistance in the switch is not guaranteed to be low enough, a safer design can be used.

The Switch-0 pin can be left unconnected if its functionality is not used.

10.2.4 Reset

The Reset-n pin could be sensitive to ESD discharge but the sensitivity can be decreased by adding a pull-up resistor and a shunt capacitor (e.g. see the design examples below), the values depends on the host design and need to be optimized for each application.

The Reset-n pin can be connected to an external reset source, see Figure 28 for a switch example. If the reset signal is connected to an output signal it must be an open drain collector, see Figure 29.

The Reset-n pin can be left unconnected if not used.

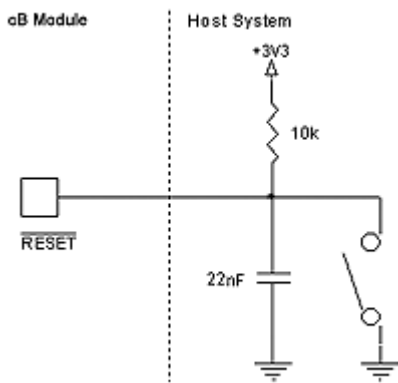

Figure 28: A reset switch.

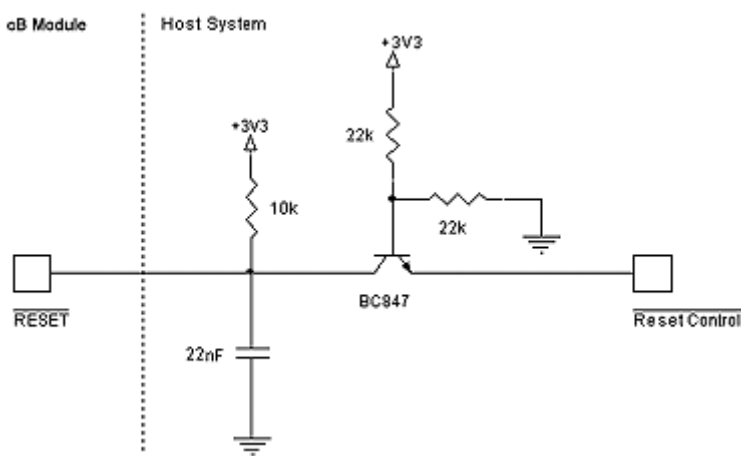

Figure 29: Design of an open collector reset from an active high output.

10.2.5 A Complete 5V Host System Interface

Figure 30 is a complete 5V host system interface example with an RGB LED and two switches (except the serial interface, see section [Serial Interface](#) for information). The design is based on the LM339 Quad OP-amp instead of logic gates.

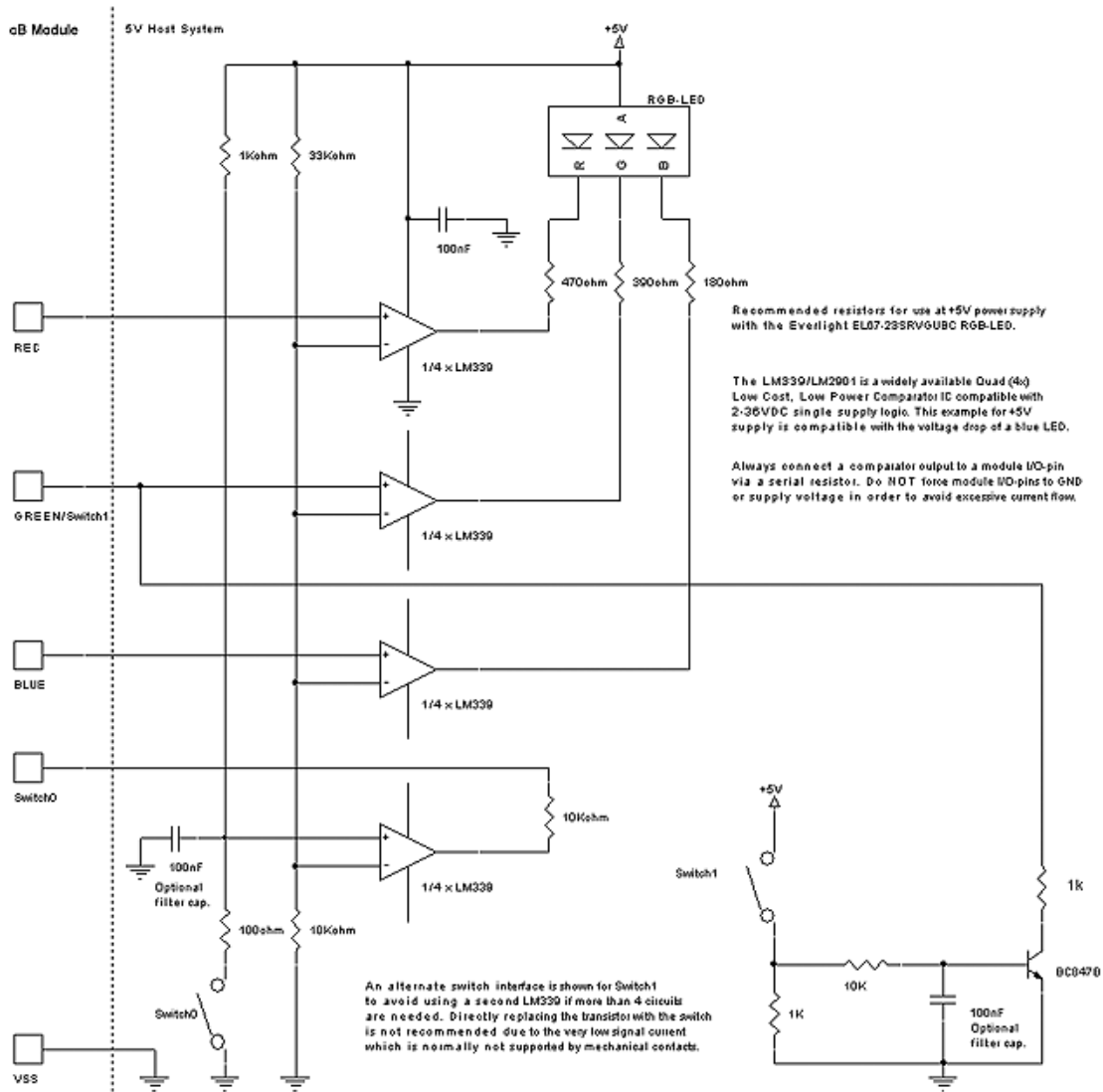

Figure 30: A complete 5V host interface with operational amplifier.