

Service Manual

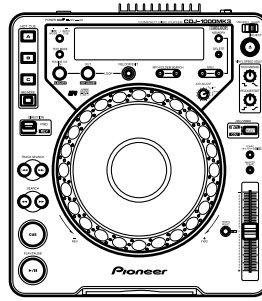

CDJ-1000MK3

ORDER NO.
RRV3353

COMPACT DISC PLAYER

CDJ-1000MK3

THIS MANUAL IS APPLICABLE TO THE FOLLOWING MODEL(S) AND TYPE(S).

Model	Type	Power Requirement	Remarks
CDJ-1000MK3	KUCXJ	AC 120V	
CDJ-1000MK3	WYXJ5	AC 220-240V	
CDJ-1000MK3	TLFXJ	AC 110-240V	



For details, refer to "Important Check Points for good servicing".

SAFETY INFORMATION



This service manual is intended for qualified service technicians ; it is not meant for the casual do-it-yourselfer. Qualified technicians have the necessary test equipment and tools, and have been trained to properly and safely repair complex products such as those covered by this manual.

Improperly performed repairs can adversely affect the safety and reliability of the product and may void the warranty. If you are not qualified to perform the repair of this product properly and safely, you should not risk trying to do so and refer the repair to a qualified service technician.



WARNING

This product contains lead in solder and certain electrical parts contain chemicals which are known to the state of California to cause cancer, birth defects or other reproductive harm.

Health & Safety Code Section 25249.6 - Proposition 65



NOTICE

(FOR CANADIAN MODEL ONLY)

Fuse symbols  (fast operating fuse) and/or  (slow operating fuse) on PCB indicate that replacement parts must be of identical designation.

REMARQUE

(POUR MODÈLE CANADIEN SEULEMENT)

Les symboles de fusible  (fusible de type rapide) et/ou  (fusible de type lent) sur CCI indiquent que les pièces de remplacement doivent avoir la même désignation.

(FOR USA MODEL ONLY)

1. SAFETY PRECAUTIONS

The following check should be performed for the continued protection of the customer and service technician.

LEAKAGE CURRENT CHECK

Measure leakage current to a known earth ground (water pipe, conduit, etc.) by connecting a leakage current tester such as Simpson Model 229-2 or equivalent between the earth ground and all exposed metal parts of the appliance (input/output terminals, screwheads, metal overlays, control shaft, etc.). Plug the AC line cord of the appliance directly into a 120V AC 60 Hz outlet and turn the AC power switch on. Any current measured must not exceed 0.5 mA.

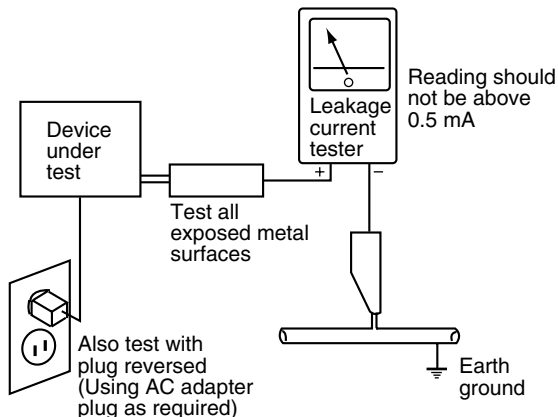

AC Leakage Test

ANY MEASUREMENTS NOT WITHIN THE LIMITS OUTLINED ABOVE ARE INDICATIVE OF A POTENTIAL SHOCK HAZARD AND MUST BE CORRECTED BEFORE RETURNING THE APPLIANCE TO THE CUSTOMER.

2. PRODUCT SAFETY NOTICE

Many electrical and mechanical parts in the appliance have special safety related characteristics. These are often not evident from visual inspection nor the protection afforded by them necessarily can be obtained by using replacement components rated for voltage, wattage, etc. Replacement parts which have these special safety characteristics are identified in this Service Manual.

Electrical components having such features are identified by marking with a  on the schematics and on the parts list in this Service Manual.

The use of a substitute replacement component which does not have the same safety characteristics as the PIONEER recommended replacement one, shown in the parts list in this Service Manual, may create shock, fire, or other hazards.

Product Safety is continuously under review and new instructions are issued from time to time. For the latest information, always consult the current PIONEER Service Manual. A subscription to, or additional copies of, PIONEER Service Manual may be obtained at a nominal charge from PIONEER.

IMPORTANT

THIS PIONEER APPARATUS CONTAINS LASER OF CLASS 1. SERVICING OPERATION OF THE APPARATUS SHOULD BE DONE BY A SPECIALLY INSTRUCTED PERSON.

LASER DIODE CHARACTERISTICS

MAXIMUM OUTPUT POWER : 5 mW
WAVELENGTH : 780 – 785 nm

WARNING !

THE AEL (ACCESSIBLE EMISSION LEVEL) OF THE LASER POWER OUTPUT IS LESS THAN **CLASS 1** BUT THE LASER COMPONENT IS CAPABLE OF EMITTING RADIATION EXCEEDING THE LIMIT FOR **CLASS 1**. A SPECIALLY INSTRUCTED PERSON SHOULD DO SERVICING OPERATION OF THE APPARATUS.

LABEL CHECK

for WYXJ5 and KUCXJ types

CAUTION	CLASS 3B INVISIBLE LASER RADIATION WHEN OPEN. AVOID EXPOSURE TO BEAM.	VORSICHT	BEI GEÖFFNETER ABDECKUNG IST UNSICHTBARE LASERSTRAHLUNG DER KLASSE 3B IM GERÄTEINNEREN VORHANDEN. NICHT BEIM LASERSTRAHLAUSSETZEN!
ATTENTION	RADIATIONS LASER INVISIBLES DE CLASSE 3B QUAND OUVERT. ÉVITEZ TOUTE EXPOSITION AU FASCEAU.	PRECAUCION	CUANDO SE ABRE, HAY RADIACION LASER DE CLASE 3B INVISIBLE. EVITE LA EXPOSICION A LOS RAYOS LASER.
ADVARSEL	KLASSE 3B URSYNLIG LASERSTRÅLING VED ÅBNING.	VARD!	VIATTRESSA (ELET ALTHVA INKYNATTÖMALLE LUKNAN 3B LASERSKATEKILLE. ALÄ VÄTSG SÄTTESSEN.
VARNING	KLASS 3B ØSYNLIG LASERSTRÅLING NÅR DENNEN DEL ER ÖPPNAD. UNDRY ATT UTSÆTTA DIG FOR STRÅLEN.		DRW2308-A

(DRW2308)

for TLFXJ type

CAUTION : CLASS 3B INVISIBLE LASER RADIATION WHEN OPEN, AVOID EXPOSURE TO THE BEAM.

注意：打開時會有CLASS 3B不可見鐳射輻射，請勿受鐳射束輻射。

DRW2248

(DRW2248)

A technical line drawing of the CD player's internal chassis. A dashed rectangular box highlights a specific area on the top surface, which is indicated by a callout line pointing to the label information provided in the adjacent blocks.

CLASS 1 LASER PRODUCT
1类激光产品

(Printed on the bottom plate)

A technical drawing of the bottom plate of the CD player. A dashed rectangular box highlights a label area, which is pointed to by a callout line from the label information provided in the adjacent blocks.

Additional Laser Caution

- Laser Interlock Mechanism**
The position of the switch (S2401) for detecting loading completion is detected by the system microprocessor, and the design prevents laser diode oscillation when the switch is not in LPS1 terminal side (when the mechanism is not clamped and LPS1 signal is high level.) Thus, the interlock will no longer function if the switch is deliberately set to LPS1 terminal side. (if LPS1 signal is low level). In the test mode* the interlock mechanism will not function. Laser diode oscillation will continue, if pin 5 of AN22022A (IC601) on the MAIN Assy is connected to GND, or else the terminals of Q603 are shorted to each other (fault condition).
- When the cover is opened, close viewing of the objective lens with the naked eye will cause exposure to a Class 1 laser beam.

CDJ-1000MK3

5

6

7

8

3

[Important Check Points for Good Servicing]

In this manual, procedures that must be performed during repairs are marked with the below symbol. Please be sure to confirm and follow these procedures.

1. Product safety



Please conform to product regulations (such as safety and radiation regulations), and maintain a safe servicing environment by following the safety instructions described in this manual.

- ① Use specified parts for repair.

Use genuine parts. Be sure to use important parts for safety.

- ② Do not perform modifications without proper instructions.

Please follow the specified safety methods when modification (addition/change of parts) is required due to interferences such as radio/TV interference and foreign noise.

- ③ Make sure the soldering of repaired locations is properly performed.

When you solder while repairing, please be sure that there are no cold solder and other debris. Soldering should be finished with the proper quantity. (Refer to the example)

- ④ Make sure the screws are tightly fastened.

Please be sure that all screws are fastened, and that there are no loose screws.

- ⑤ Make sure each connectors are correctly inserted.

Please be sure that all connectors are inserted, and that there are no imperfect insertion.

- ⑥ Make sure the wiring cables are set to their original state.

Please replace the wiring and cables to the original state after repairs. In addition, be sure that there are no pinched wires, etc.

- ⑦ Make sure screws and soldering scraps do not remain inside the product.

Please check that neither solder debris nor screws remain inside the product.

- ⑧ There should be no semi-broken wires, scratches, melting, etc. on the coating of the power cord.

Damaged power cords may lead to fire accidents, so please be sure that there are no damages. If you find a damaged power cord, please exchange it with a suitable one.

- ⑨ There should be no spark traces or similar marks on the power plug.

When spark traces or similar marks are found on the power supply plug, please check the connection and advise on secure connections and suitable usage. Please exchange the power cord if necessary.

- ⑩ Safe environment should be secured during servicing.

When you perform repairs, please pay attention to static electricity, furniture, household articles, etc. in order to prevent injuries. Please pay attention to your surroundings and repair safely.

2. Adjustments



To keep the original performance of the products, optimum adjustments and confirmation of characteristics within specification. Adjustments should be performed in accordance with the procedures/instructions described in this manual.

3. Lubricants, Glues, and Replacement parts



Use grease and adhesives that are equal to the specified substance. Make sure the proper amount is applied.

4. Cleaning



For parts that require cleaning, such as optical pickups, tape deck heads, lenses and mirrors used in projection monitors, proper cleaning should be performed to restore their performances.

5. Shipping mode and Shipping screws



To protect products from damages or failures during transit, the shipping mode should be set or the shipping screws should be installed before shipment. Please be sure to follow this method especially if it is specified in this manual.

CONTENTS

1. SPECIFICATIONS	6
2. EXPLODED VIEWS AND PARTS LIST	8
2.1 PACKING SECTION	8
2.2 EXTERIOR SECTION	10
2.3 CONTROL PANEL SECTION	12
2.4 SLOT-IN MECHA. SECTION	14
2.5 TRAVERSE MECHA. ASSY-S	16
3. BLOCK DIAGRAM AND SCHEMATIC DIAGRAM	18
3.1 BLOCK DIAGRAM	18
3.1.1 SIGNAL SECTION	18
3.1.2 POWER SUPPLY SECTION	20
3.2 OVERALL WIRING DIAGRAM	22
3.3 MAIN ASSY (1/4)	24
3.4 MAIN ASSY (2/4)	26
3.5 MAIN ASSY (3/4)	28
3.6 MAIN (4/4) and SLMB ASSYS	30
3.7 SPCN, INSW and SDCB ASSYS	32
3.8 MJCB ASSY	34
3.9 MFLB ASSY	36
3.10 SLDB and RSWB ASSYS	38
3.11 JFLB, KSWB and JOGB ASSYS	40
3.12 SW POWER SUPPLY ASSY	42
3.13 WAVEFORMS	44
3.14 VOLTAGES	53
4. PCB CONNECTION DIAGRAM	55
4.1 MAIN ASSY	56
4.2 SLMB, SPCN, INSW and SDCB ASSYS	60
4.3 MJCB ASSY	62
4.4 MFLB and RSWB ASSYS	64
4.5 SLDB ASSY	68
4.6 KSWB ASSY	69
4.7 JFLB and JOGB ASSYS	70
4.8 SW POWER SUPPLY ASSY	72
5. PCB PARTS LIST	73
6. ADJUSTMENT	77
6.1 TEMPO ZERO POINT ADJUSTMENT	77
6.2 MODE FOR CHECKING THE LOAD ON THE JOG DIAL	78
7. GENERAL INFORMATION	79
7.1 DIAGNOSIS	79
7.1.1 SERVICE MODE	79
7.1.2 HOW TO UPGRADE THE SOFTWARE OF THE MICROCOMPUTER	87
7.1.3 SEQUENCE	88
7.1.4 DISASSEMBLY	90
7.2 PARTS	99
7.2.1 IC	99
8. PANEL FACILITIES	113
8.1 PANEL SECTION	113
8.2 DISPLAY SECTION	115

1. SPECIFICATIONS

1. General

System	Compact disc digital audio system
Power requirements	AC 120 V, 60 Hz (KUCXJ type) AC 220 V to 240V, 50/60 Hz (WYXJ5 type) AC 110 V to 240V, 50/60 Hz (TLFXJ type)
Power consumption	28 W (KUCXJ type) 27 W (WYXJ5 type) 27 W (TLFXJ type)
Operating temperature	+5 °C to +35 °C
Operating humidity	5 % to 85 % (There should be no condensation of moisture.)
Weight	4.2 kg (9.26 lb)
Dimensions	320 (W) x 370 (D) x 105 (H) mm 12 - 5/8 (W) x 14 - 9/16 (D) x 4 - 1/8 (H) in

2. Audio section

Frequency response	4 Hz to 20 kHz
Signal-to-noise ratio	115 dB or more (JEITA)
Distortion	0.006 % (JEITA)

3. Accessories

● Operating instructions	1
● Power cord (KUCXJ and WYXJ5 types)	1
● Power cord (TLFXJ type)	2
● Audio cable	1
● Control cord	1
● Forced eject pin (housed in a groove in the bottom panel)	1
● SD memory card	1
● Limited warranty (KUCXJ only).....	1

NOTE:

Specifications and design are subject to possible modification without notice.

Accessories

Audio Cable
(VDE1064) L=1.5m



Control Cord
(XDE3063) L=1 m



Power Cord
(KUCXJ type : ADG7021)
(WYXJ5 : ADG1154)
(TLFXJ type : ADG1154, ADG7097)



Forced Eject Pin
(DEX1013)



SD Memory Card
(DWX2622)



AC power cord for TLFXJ type

The type of cord which can be used depends on the power voltage in each region or country. Please make sure you use the correct cord due to the possibility of fire or other hazard if used incorrectly (see below).

AC power cord and converter plug use

Region

Plug type

ADG1154

For European type region

Caution

Do not use this power cord set in Taiwan.

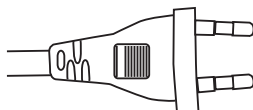

European two-pin plug

ADG7097

For Taiwan exclusively

Caution

For use in Taiwan only.

In other areas, please do not use.

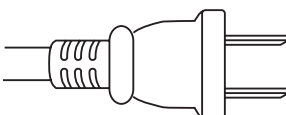

Taiwanese two-pin flat-bladed plug



5



6



7



8



A



B



C



D



E



F



5



6

CDJ-1000MK3



7





8

7



2. EXPLODED VIEWS AND PARTS LIST

- NOTES:
- Parts marked by "NSP" are generally unavailable because they are not in our Master Spare Parts List.
 - The  mark found on some component parts indicates the importance of the safety factor of the part. Therefore, when replacing, be sure to use parts of identical designation.
 - Screws adjacent to  mark on product are used for disassembly.
 - For the applying amount of lubricants or glue, follow the instructions in this manual. (In the case of no amount instructions, apply as you think it appropriate.)

2.1 PACKING SECTION

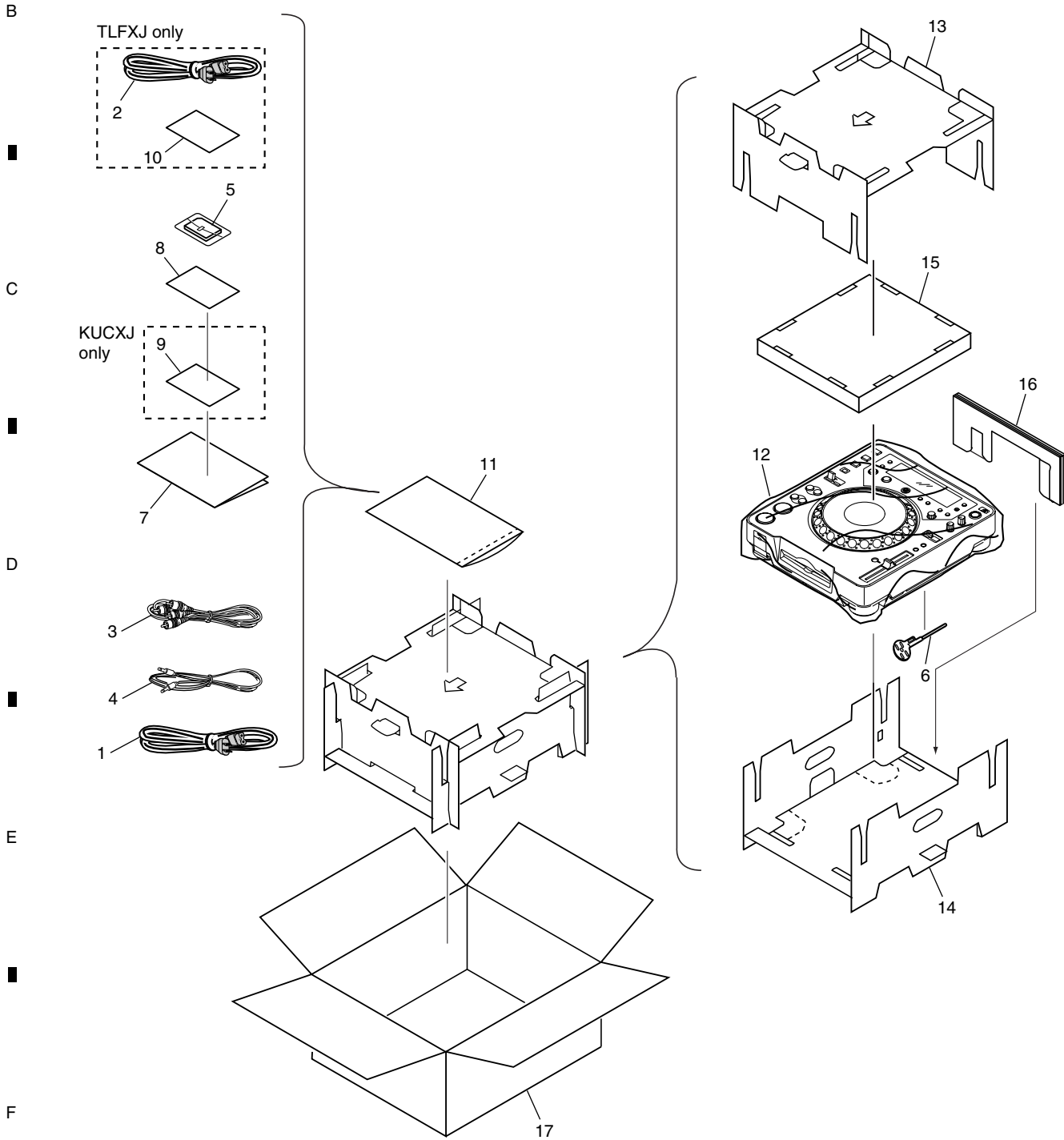

(1) PACKING SECTION PARTS LIST

<u>Mark No.</u>	<u>Description</u>	<u>Part No.</u>
⚠ 1	Power Cord	See Contrast table (2)
⚠ 2	Power Cord	See Contrast table (2)
3	Audio Cable (L = 1.5 m)	VDE1064
4	Control Cord (L = 1 m)	XDE3063
5	SD Memory Card	DWX2622
6	Forced Eject Pin	DEX1013
7	Operating Instructions	See Contrast table (2)
NSP 8	User Seat	DRM1262
NSP 9	Limited Warranty	See Contrast table (2)
10	Caution Card SB	See Contrast table (2)
NSP 11	Polyethylene Bag (0.06 x 230 x 340)	AHG7117
12	Packing Sheet	AHG7010
13	Pad (A)	DHA1533
14	Pad (B)	DHA1534
15	Pad (C)	DHA1535
16	Pad (D)	DHA1536
17	Packing Case	See Contrast table (2)

(2) CONTRAST TABLE

CDJ-1000MK3/KUCXJ, WYXJ5 and TLFXJ are constructed the same except for the following:

Mark	No.	Symbol and Description	CDJ-1000MK3/KUCXJ	CDJ-1000MK3/WYXJ5	CDJ-1000MK3/TLFXJ
⚠	1	Power Cord	ADG7021	ADG1154	ADG1154
⚠	2	Power Cord	Not used	Not used	ADG7097
	7	Operating Instructions (English)	DRB1397	Not used	Not used
	7	Operating Instructions (English/French/German/Italian/Dutch/Spanish)	Not used	DRB1396	Not used
	7	Operating Instructions (English/ Spanish/ Chinese)	Not used	Not used	DRB1398
NSP	9	Limited Warranty	ARY7043	Not used	Not used
	10	Caution Card SD	Not used	Not used	ARM7064
	17	Packing Case	DHG2576	DHG2575	DHG2577

2.2 EXTERIOR SECTION

1

2

3

4

A

B

C

D

E

F

Refer to
"2.3 CONTROL PANEL SECTION".

Refer to
"2.4 SLOT-IN MECHA. SECTION".

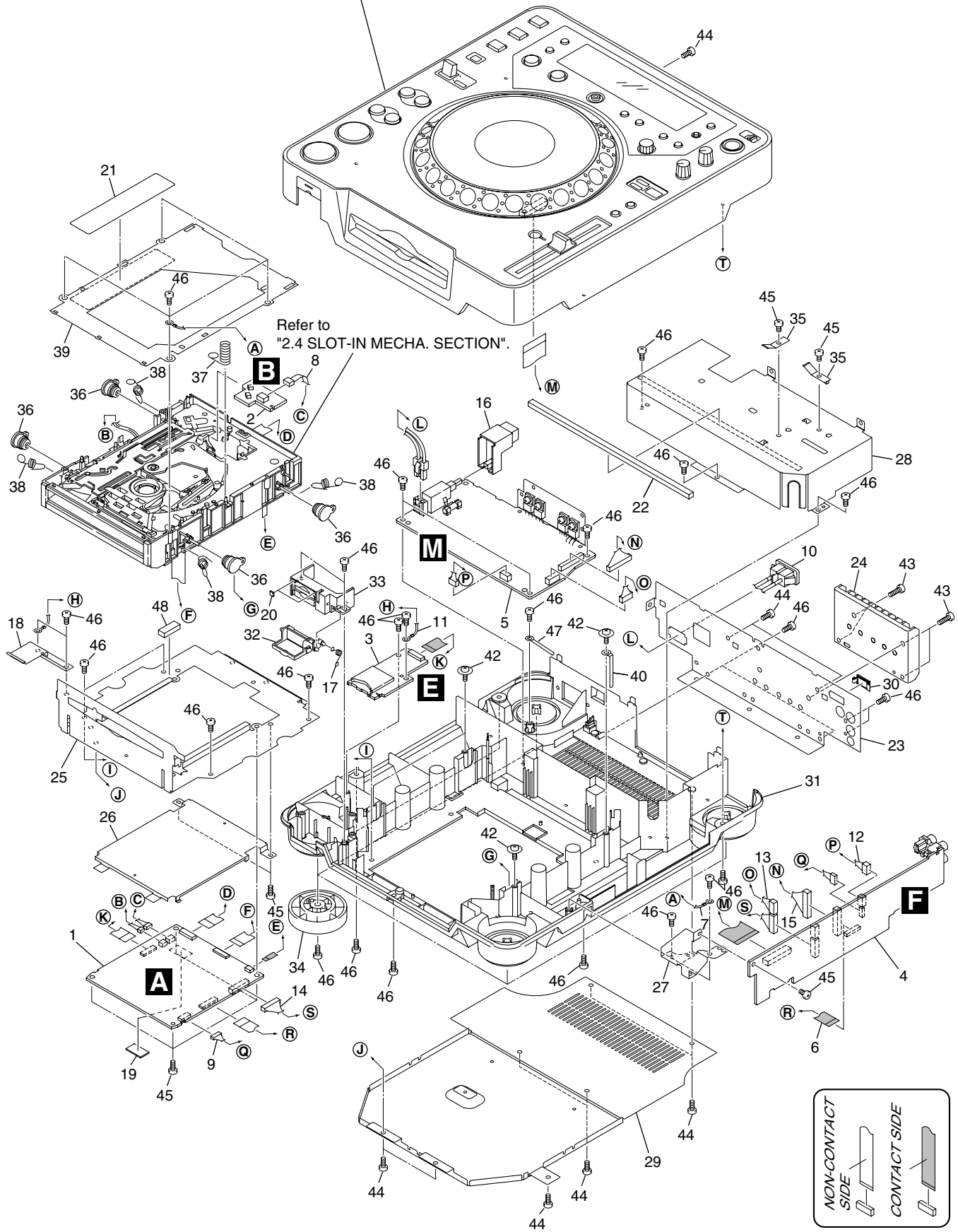

CDJ-1000MK3

1

2

3

4

(1) EXTERIOR SECTION PARTS LIST

Mark No.	Description	Part No.	Mark No.	Description	Part No.
1	MAIN Assy	DWG1591	27	Earth Plate C	DNH2715
2	SLMB Assy	DWS1366	28	Shield Box	DNH2728
3	SDCB Assy	DWX2558	29	Bottom Plate	See Contrast table (2)
4	MJCB Assy	DWG1605	30	Blind Cap	DNK4218
△	5 SW POWER SUPPLY Assy	DWR1409	31	Chassis	DNK4553
6	15P Flexible Cable	DDD1301	32	Card Door	DNK4554
7	Earth Lead Unit/300V	DDF1032	33	Card Holder	DNK4555
8	Connector Assy 3P	DKP3751	34	Insulator Assy	DXA2092
9	Connector Assy 6P	DKP3752	35	Earth Plate	VBK1070
△	10 Inlet Assy	See Contrast table (2)	36	Damper	CNV6011
11	Earth Lead Unit/300V	PDF1104	37	Earth Spring	DBH1398
12	Connector Assy	PF04PP-Q12	38	Float Spring G5	DBH1494
13	Connector Assy	PF06PP-Q15	39	Mecha. Plate	DNH2339
14	Connector Assy	PF09PP-B12	40	Cord Clamper	RNH-184
15	Connector Assy	PF11EE-R15	41	Binder (SKB-90BK)	ZCA-SKB90BK
16	Power Button	DAC2314	42	DM Screw	DBA1260
17	Door Spring	DBH1565	43	Screw	BBT30P100FTB
18	Card Spring	DBK1295	44	Screw	BBZ30P060FTB
NSP	19 Silicone Sheet D5 L	DEB1456	45	Screw	BBZ30P060FTC
20	Door Cushion	DEB1780	46	Screw	BPZ30P080FTB
21	Laser Caution	See Contrast table (2)	NSP	47 Cord Clamper (069Z)	ZCB-069Z
22	Dust Guard	DEC2939	48	FFC Guard	DEC2586
NSP	23 Rear Panel	See Contrast table (2)			
24	Heatsink	DNG1099			
25	PCB Stay	DNH2711			
26	Shield Case	DNH2712			

(2) CONTRAST TABLE

CDJ-1000MK3/KUCXJ, WYXJ5 and TLFJ are constructed the same except for the following:

Mark	No.	Symbol and Description	CDJ-1000MK3/KUCXJ	CDJ-1000MK3/WYXJ5	CDJ-1000MK3/TLFJ
△	10	Inlet Assy	DKP3754	DKP3753	DKP3753
	21	Laser Caution (7L)	DRW2308	DRW2308	Not used
	21	Laser Caution	Not used	Not used	DRW2248
NSP	23	Rear Panel	DNC1765	DNC1758	DNC1766
	29	Bottom Plate	DNH2710	DNH2710	DNH2732

2.3 CONTROL PANEL SECTION

A

B

C

D

E

F

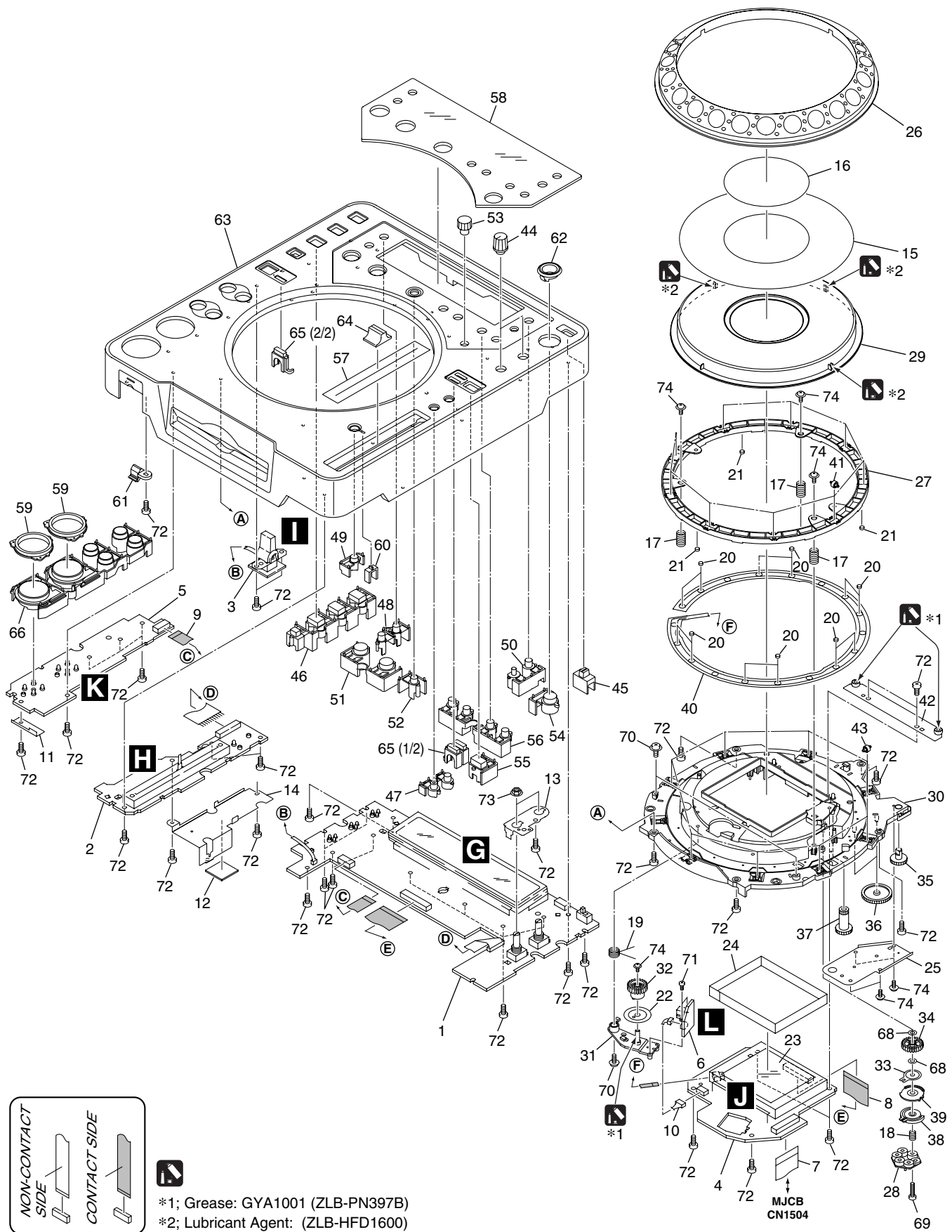

*1; Grease: GYA1001 (ZLB-PN397B)
 *2; Lubricant Agent: (ZLB-HFD1600)

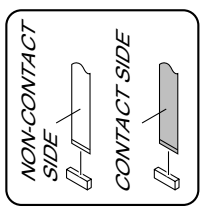

CDJ-1000MK3

5 6
CONTROL PANEL SECTION PARTS LIST

<u>Mark No.</u>	<u>Description</u>	<u>Part No.</u>	<u>Mark No.</u>	<u>Description</u>	<u>Part No.</u>
1	MFLB Assy	DWG1606	46	Set Knob (HS)	DAC1986
2	SLDB Assy	DWS1367	47	Set Knob (MT)	DAC1987
3	RSWB Assy	DWS1368	48	Set Knob (TIME)	DAC1991
4	JFLB Assy	DWG1602	49	Tempo Reset Knob	DAC1993
5	KSWB Assy	DWS1365	50	Set Knob (MEMO)	DAC1994
6	JOGB Assy	DWG1603	51	Set Knob (LOOP)	DAC1995
7	22P Flexible Cable	DDD1302	52	Re-Loop Button	DAC2347
8	25P Flexible Cable	DDD1303	53	Adjust Knob	DAC2350
9	10P Flexible Cable	DDD1304	54	Eject Knob	DAC2365
10	Connector Assy	PF04PP-B07	55	Mode Select Knob	DAC2366
11	LED Guard	DEC2932	56	Set Knob (SC)	DAC2368
12	Protect Cushion	DEC2938	57	Slide Sheet 1C	DAH2404
13	VR Stay	DNF1663	58	Display Panel	DAH2435
14	Earth Plate P	DNH2714	59	Ring Lens	DNK3880
15	JOG Plate	DAH2052	60	Tempo Lens	DNK3882
16	JOG Panel	DAH2182	61	Card Lens	DNK3885
17	SW Spring 25	DBH1514	62	Eject Guard	DNK3958
18	Gear Spring 200	DBH1525	63	Control Panel	DNK4568
19	Arm Spring	DBH1566	64	Slide Knob	DNK4656
20	SW Cushion HH48/2	DEC2538	65	Mode Lens	DNK4701
21	Ring Cushion L24/2.0	DEC2958	66	Set Knob (PLAY) Assy	DXB1909
22	Encoder Plate	DEC2889	67	•••••	
23	Protect Sheet	DEC2945	68	Washer	WA52D120D25
24	FL Sheet	DEC2946	69	Screw	BPZ20P100FTC
25	Gear Plate	DNH2713	70	Screw	IPZ30P100FTC
26	JOG B	DNK4068	71	Screw	BPZ20P060FTC
27	SW Ring	DNK4070	72	Screw	BPZ30P080FTB
28	Adjust Plate	DNK4178	73	Flange Nut M9	DBN1008
29	JOG A	DNK4556	74	Screw	DBA1265
30	JOG Holder 1000	DNK4558			
31	Gear Arm	DNK4559			
32	Gear	DNK4560			
33	Smoother	DNK4561			
34	Gear A	DNK4562			
35	Joint Gear 1	DNK4563			
36	Joint Gear 2	DNK4564			
37	Joint Gear 3	DNK4565			
38	Compressor Plate	DNK4566			
39	Cam Plate	DNK4567			
40	Sheet SW	DSX1065			
41	Roller A Assy	DXB1825			
42	JOG Stay Assy	DXB1876			
43	Roller B Assy	DXB1877			
44	Rotary Knob C	DAA1194			
45	Slide SW Knob	DAC1926			

2.4 SLOT-IN MECHA. SECTION

A
B
C
D
E
F

1 2 3 4

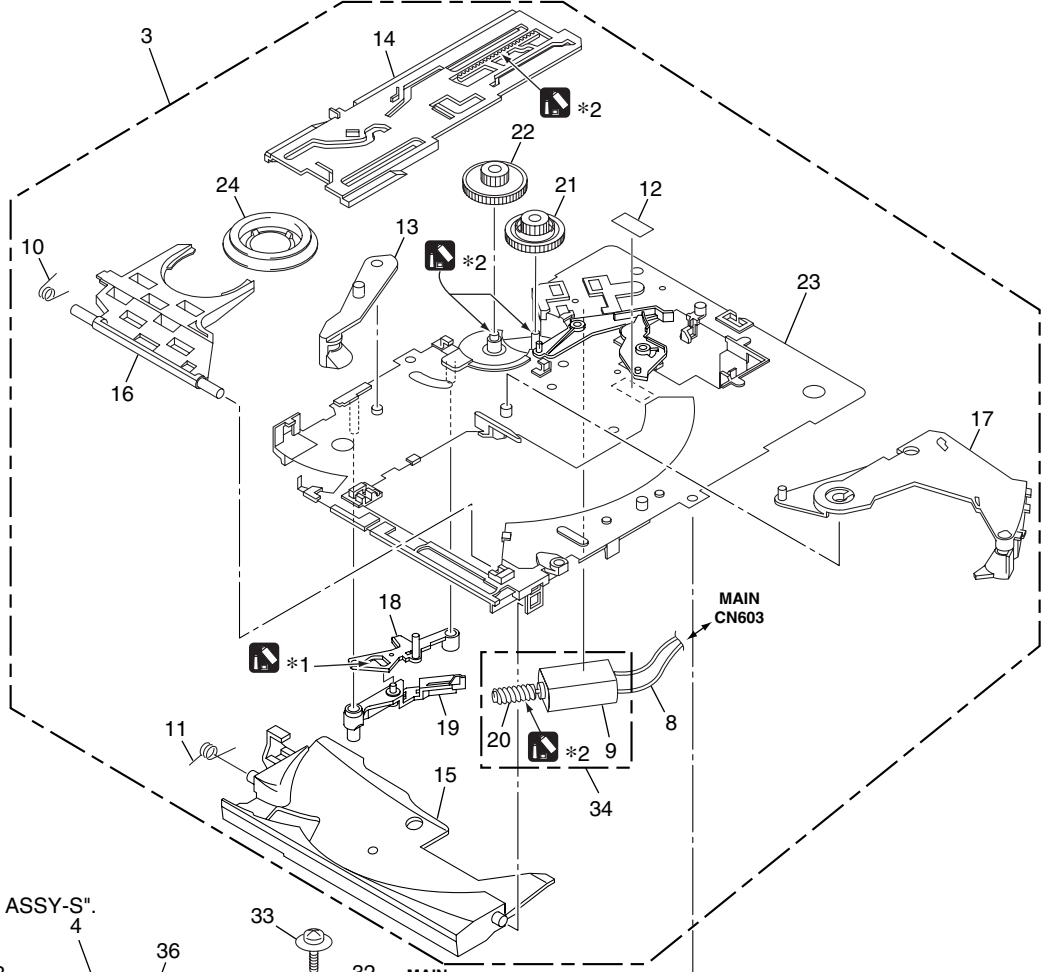

Refer to "2.5 TRAVERSE MECHA. ASSY-S".

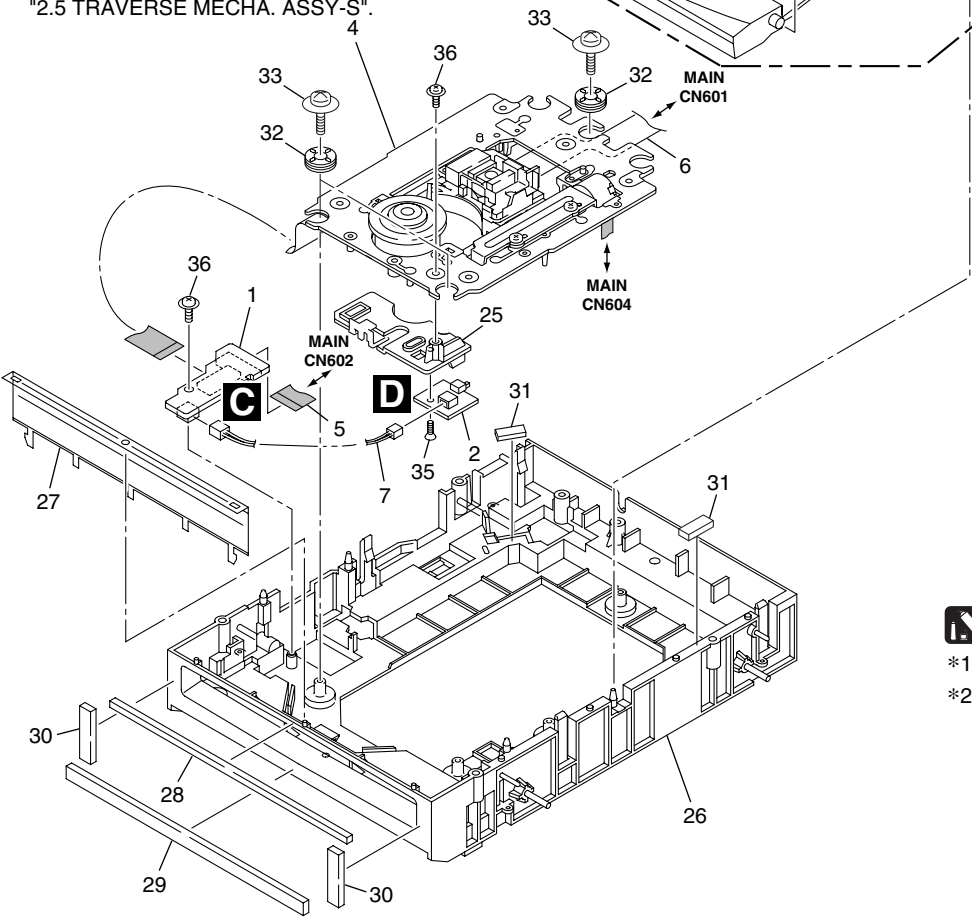

*1; Dyefree : GEM1036 (ZLX-ME413A)
 *2; Grease: GYA1001 (ZLB-PN397B)

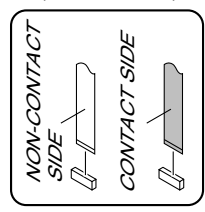

CDJ-1000MK3

1 2 3 4

5 6 7 8

SLOT-IN MECHA. SECTION PARTS LIST

<u>Mark No.</u>	<u>Description</u>	<u>Part No.</u>
1	SPCN Assy	DWX2559
2	INSW Assy	DWS1369
NSP 3	Slot-in Mecha. G11 Assy	DXA2068
4	Traverse Mecha. Assy-S	DXX2566
5	13P Flexible Cable	DDD1299
6	26P Flexible Cable	DDD1300
7	Connector Assy 2P	DKP3769
8	Connector Assy 2P	DKP3750
NSP 9	DC Motor S	DXM1230
10	Clamp Spring	DBH1374
11	Guide Spring	DBH1375
12	SW Lever Spacer	DEC2420
13	Drive Lever	DNK3406
14	Main Cam	DNK3407
15	Disc Guide	DNK3478
16	Clamp Arm	DNK3576
17	Eject Lever	DNK3684
18	Lever AP	DNK3835
19	Lever BP	DNK3836
NSP 20	Worm Gear	DNK3910
21	Loading Gear	DNK3911
22	Drive Gear	DNK3912
23	Loading Base Assy-S	DEA1022
24	Clamper D4 Assy	DXA2043
25	Inside SW Base	DNK4236
26	Float Base G11 Assy	DXB1793
27	Front Sheet	DED1132
28	Vessel Cushion A	DEC2852
29	Vessel Cushion B	DEC2853
30	Vessel Cushion C	DEC2854
31	Spacer POR (T3)	DEB1566
32	Float Rubber D3	DEB1404
33	Float Screw	DBA1286
34	Loading Motor Assy-S	DEA1008
35	Screw 2 x 5	VBA1062
36	Screw	IPZ20P060FTC

A

B

C

D

E

F

2.5 TRAVERSE MECHA. ASSY-S

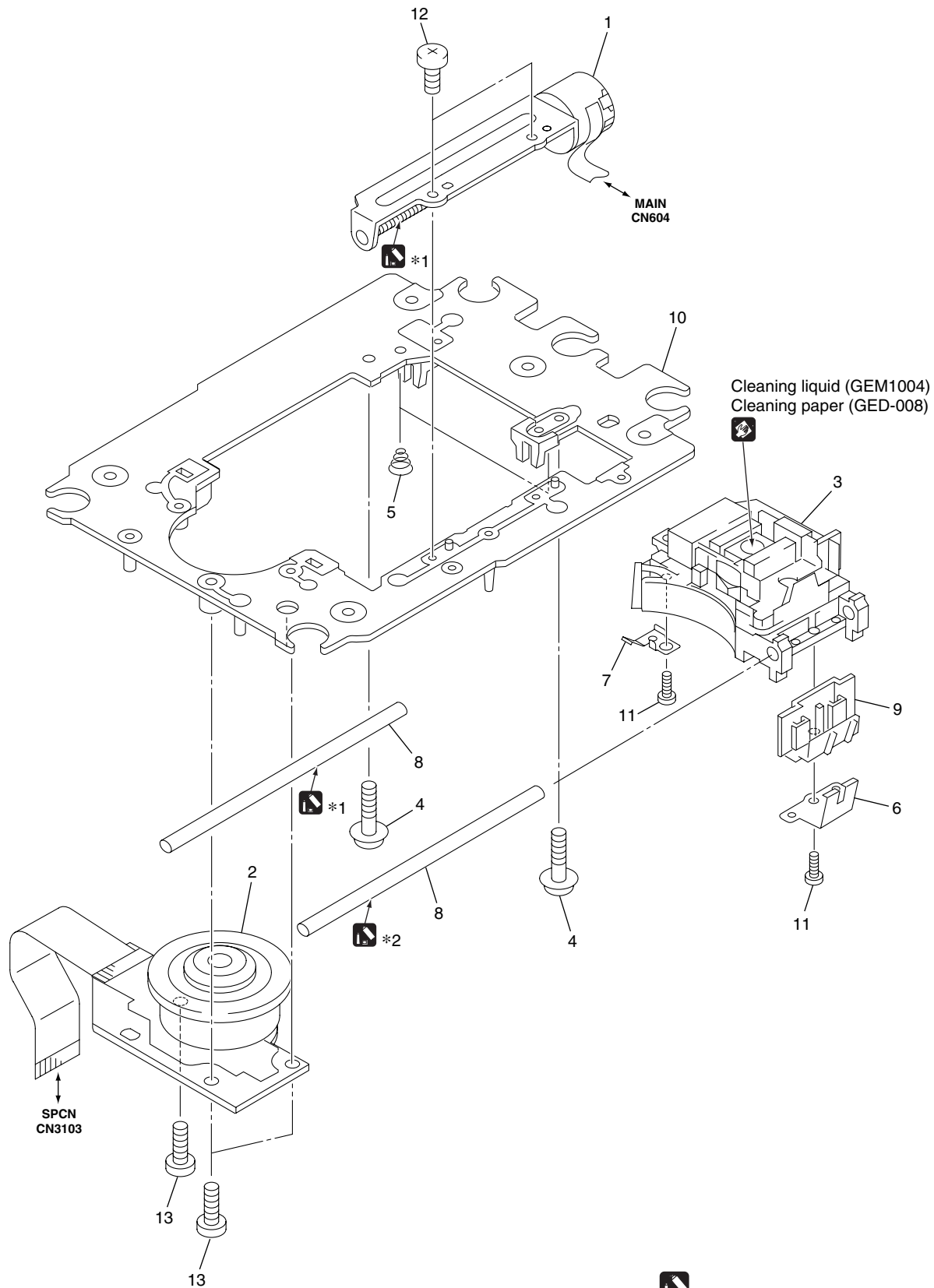

 *1; Grease: GYA1001 (ZLB-PN397B)
 *2; Grease: GEM1007 (ZLB-PN948P)

TRAVERSE MECHA. ASSY-S PARTS LIST

<u>Mark No.</u>	<u>Description</u>	<u>Part No.</u>
NSP 1	Stepping Motor	DXM1227
NSP 2	Spindle Motor G11	DXM1231
NSP 3	04RM2 Pickup Assy R	OWY8071
NSP 4	Skew Screw	DBA1263
NSP 5	Skew Spring	DBH1437
NSP 6	Joint Spring (J)	DBK1261
NSP 7	Slider Spring G11 (J)	DBK1262
NSP 8	Guide Shaft (S)	DLA1918
9	Joint	DNK3858
NSP 10	Mounting Plate G11 (J)	DNK4307
11	Screw 04	VBA1092
12	Screw	BPZ20P080FTC
13	Screw	BPZ26P080FTC

A
B
C
D
E
F

3. BLOCK DIAGRAM AND SCHEMATIC DIAGRAM

3.1 BLOCK DIAGRAM

3.1.1 SIGNAL SECTION

A

B

C

D

E

F

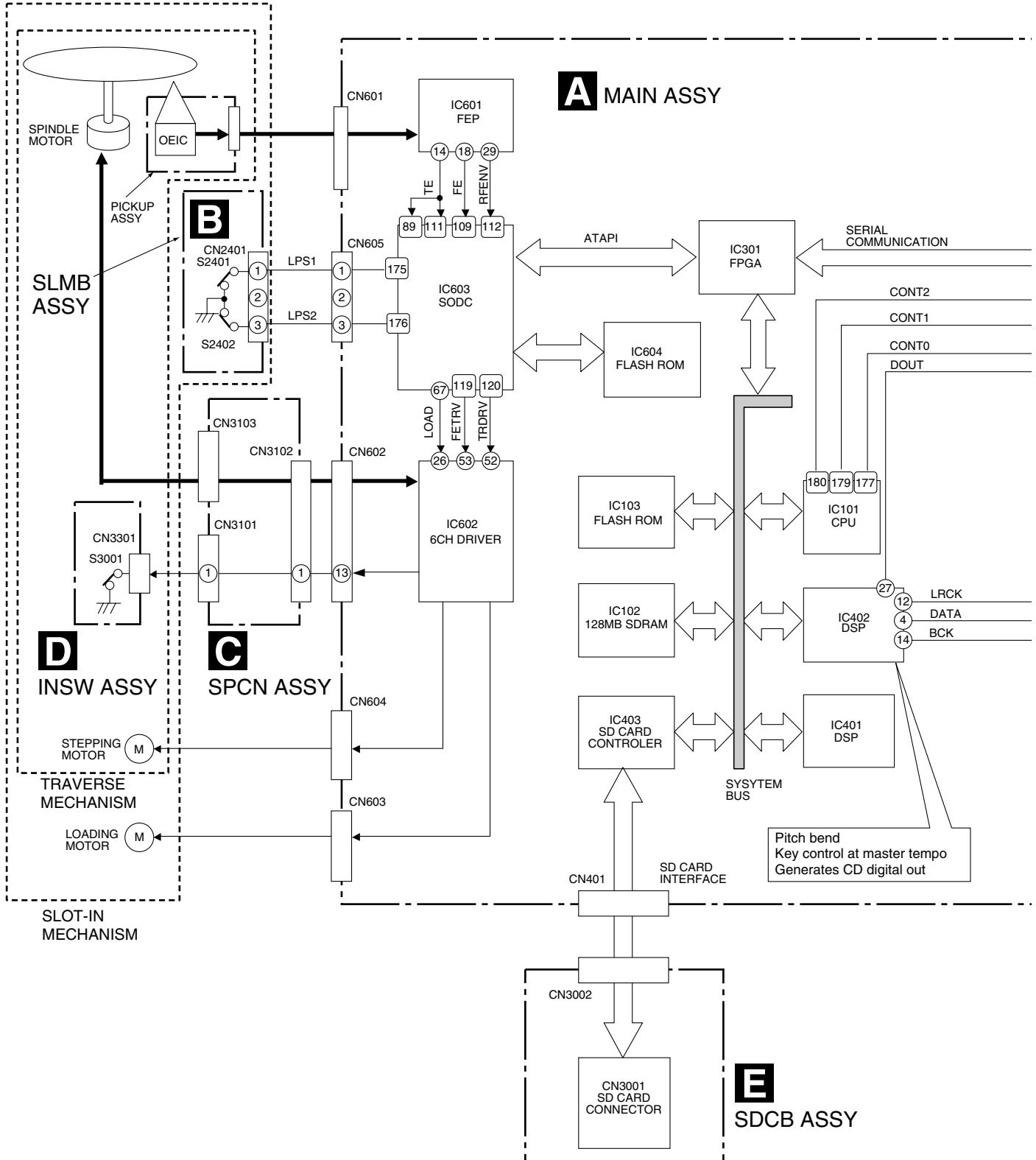

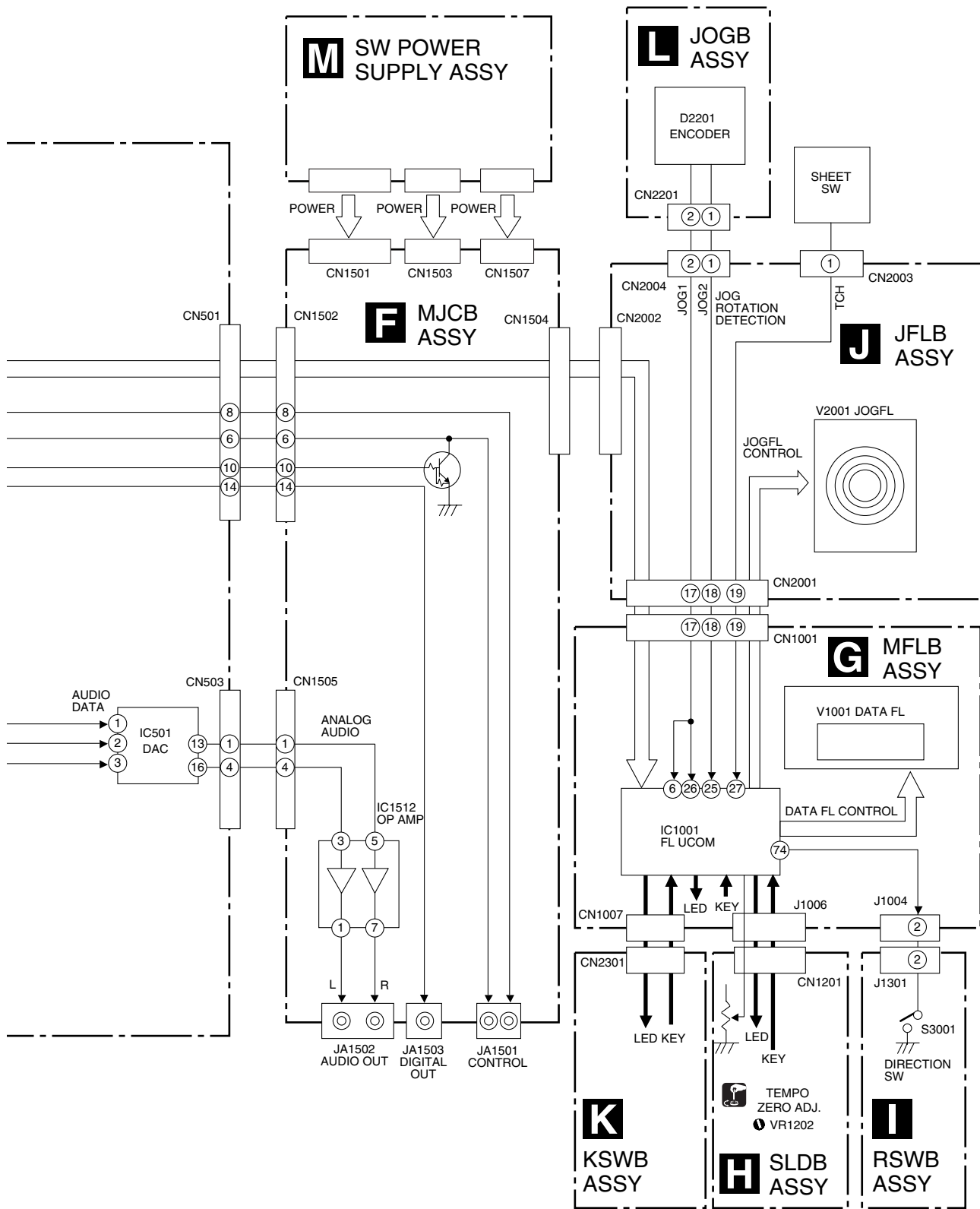

3.1.2 POWER SUPPLY SECTION

A
B
C
D
E
F

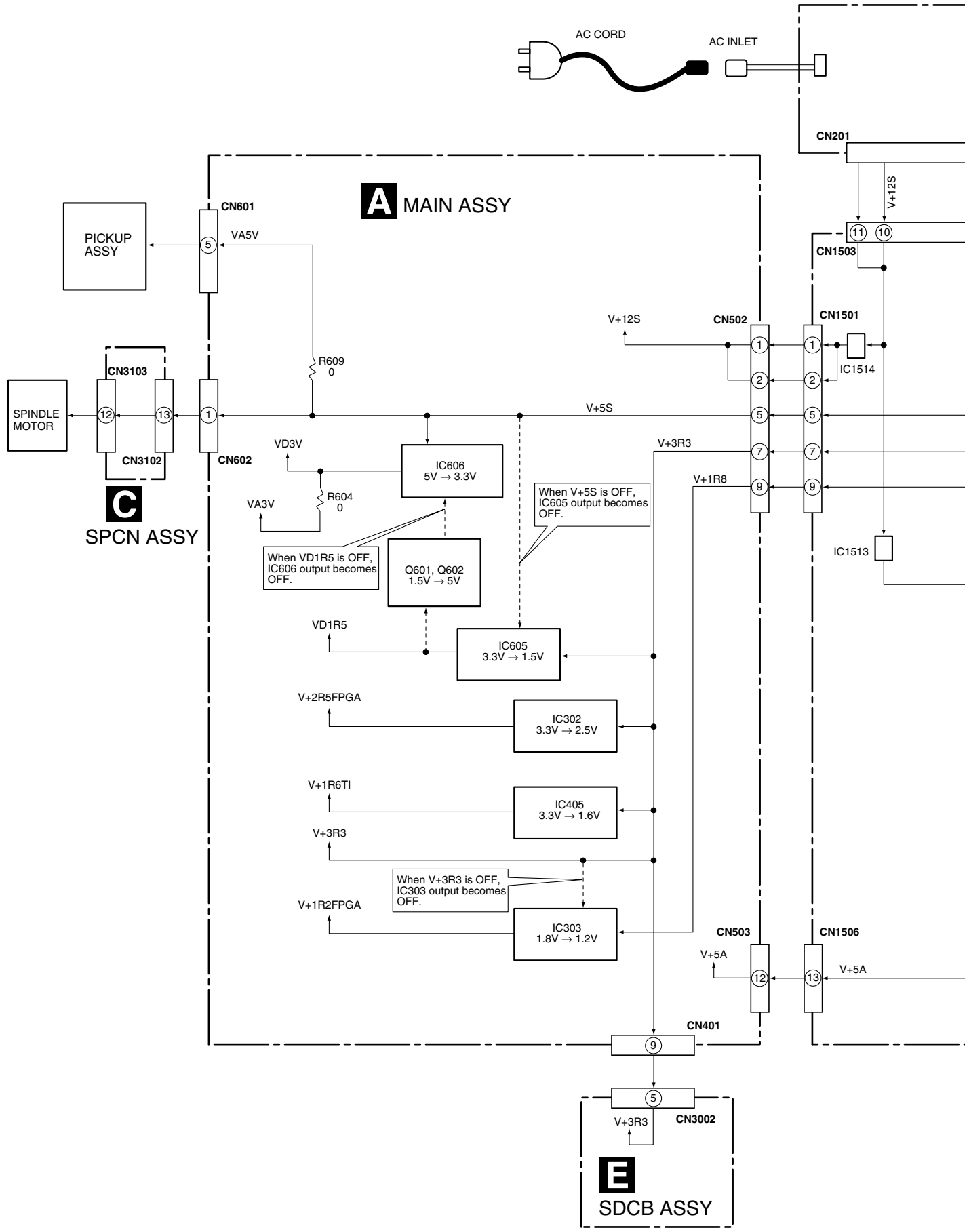

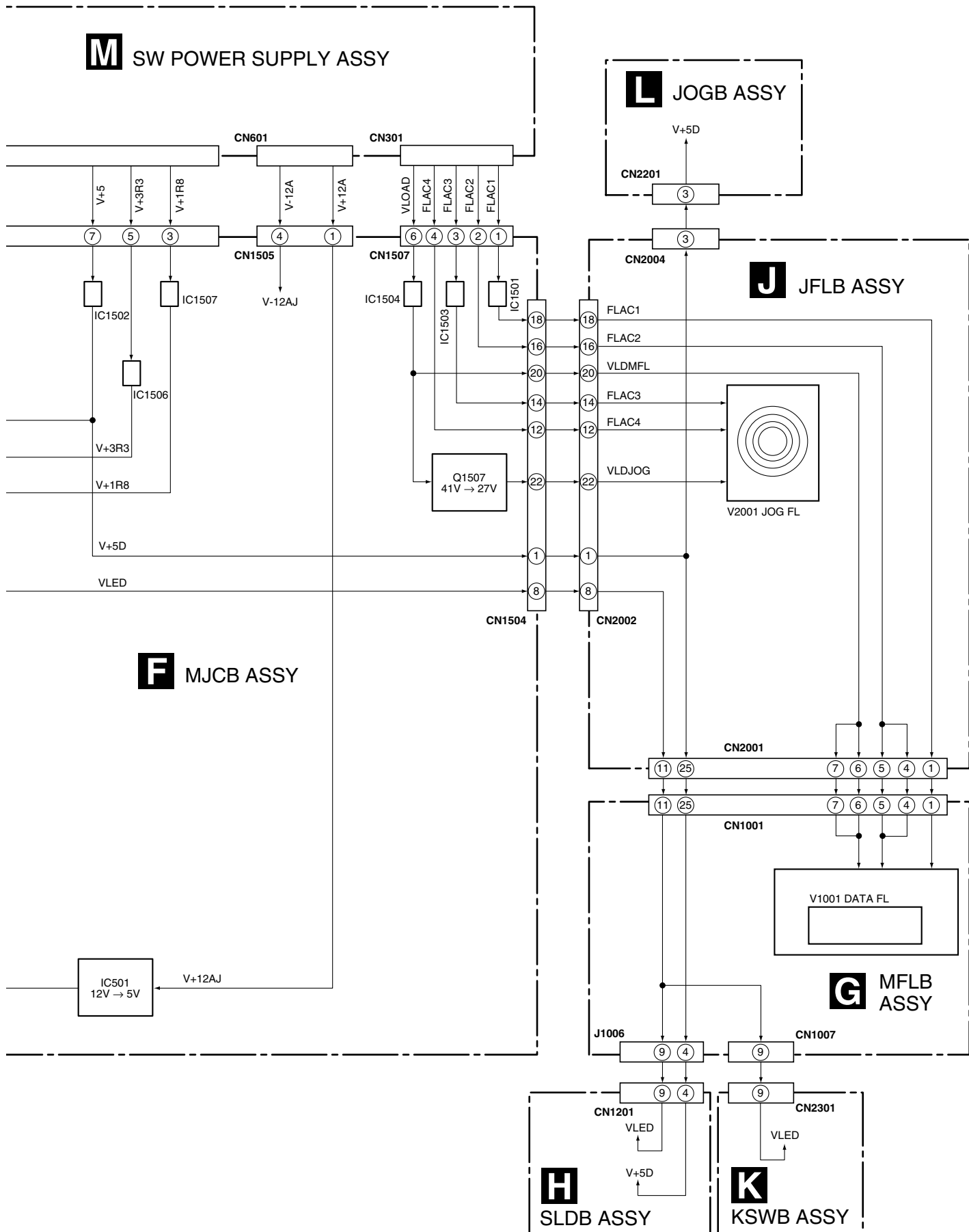

3.2 OVERALL WIRING DIAGRAM

1

2

3

4

A
B
C
D
E
F

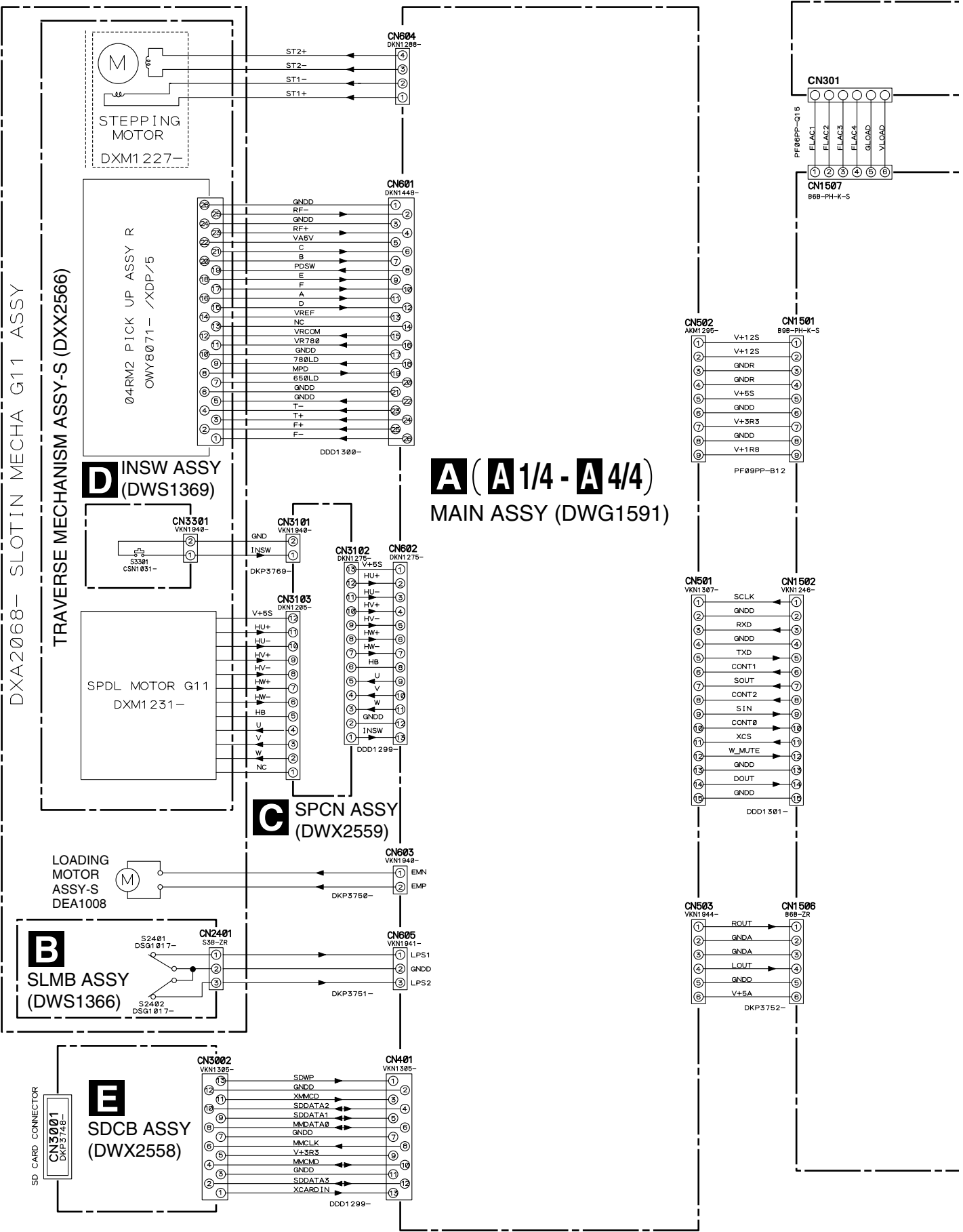

A (A 1/4 - A 4/4)
MAIN ASSY (DWG1591)

1

2

3

4

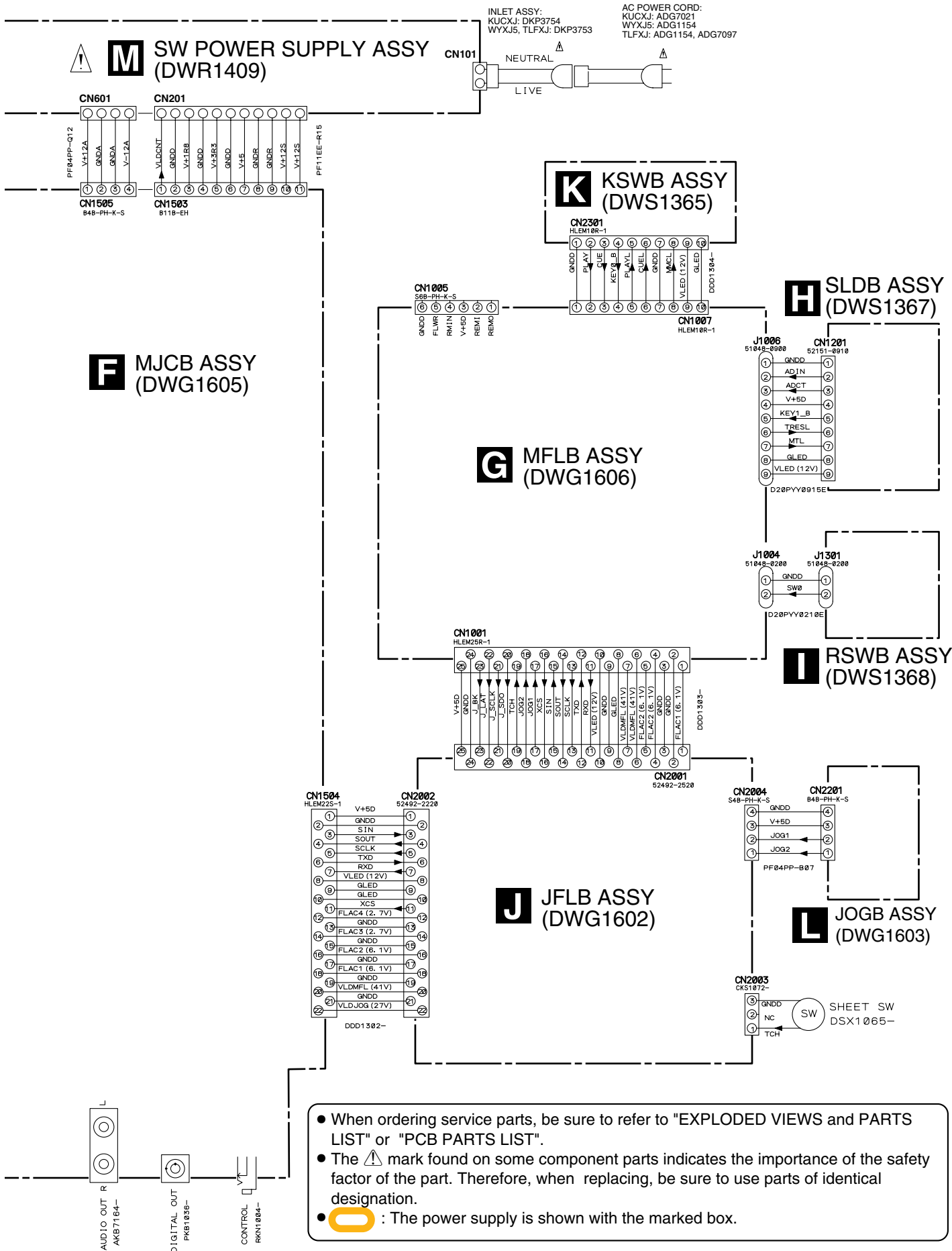

- When ordering service parts, be sure to refer to "EXPLODED VIEWS and PARTS LIST" or "PCB PARTS LIST".
- The ⚠ mark found on some component parts indicates the importance of the safety factor of the part. Therefore, when replacing, be sure to use parts of identical designation.
-  : The power supply is shown with the marked box.

3.3 MAIN ASSY (1/4)

A 1/4 MAIN ASSY (DWG1591)

A 3/4 A 2/4 A 4/4

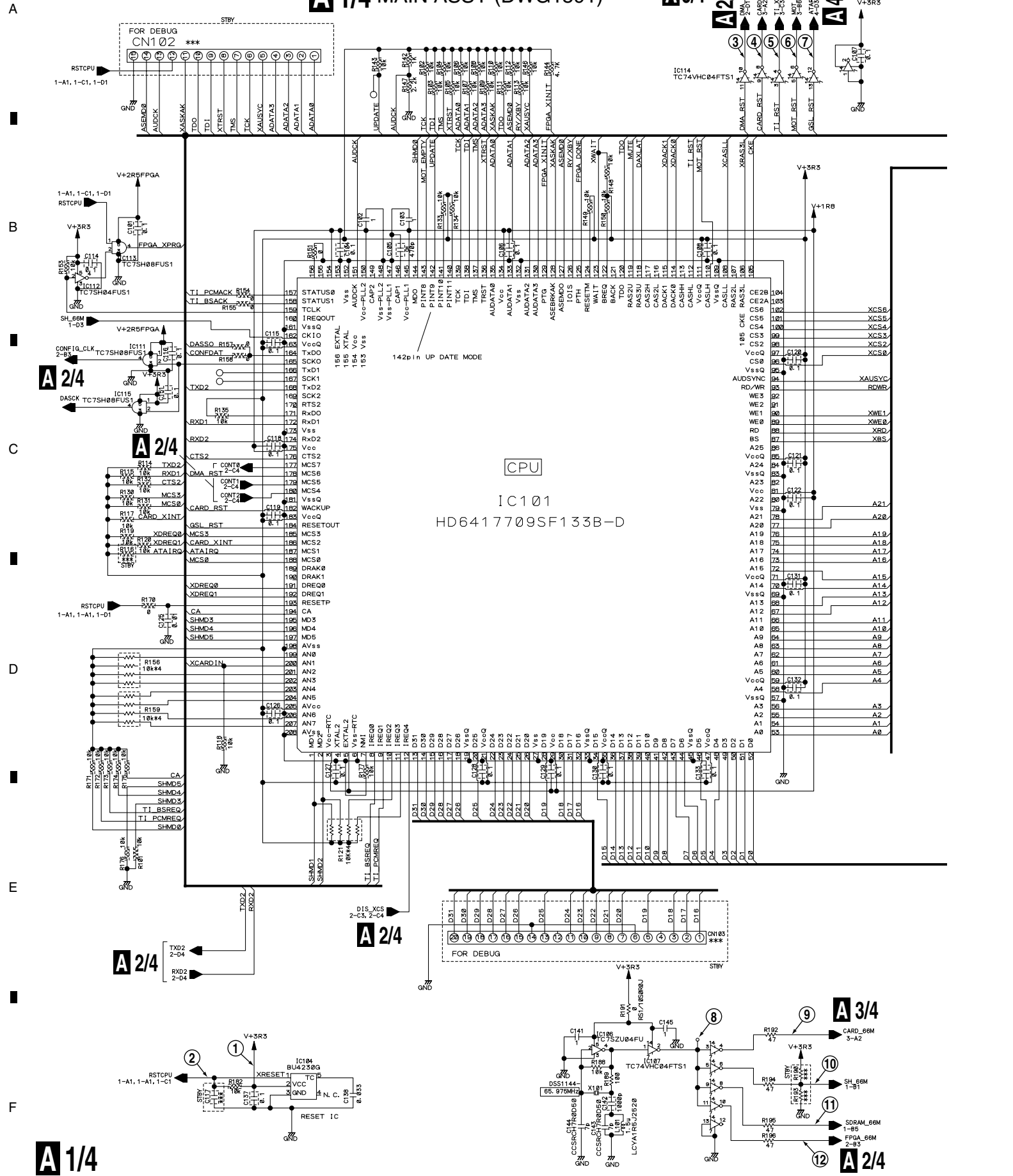

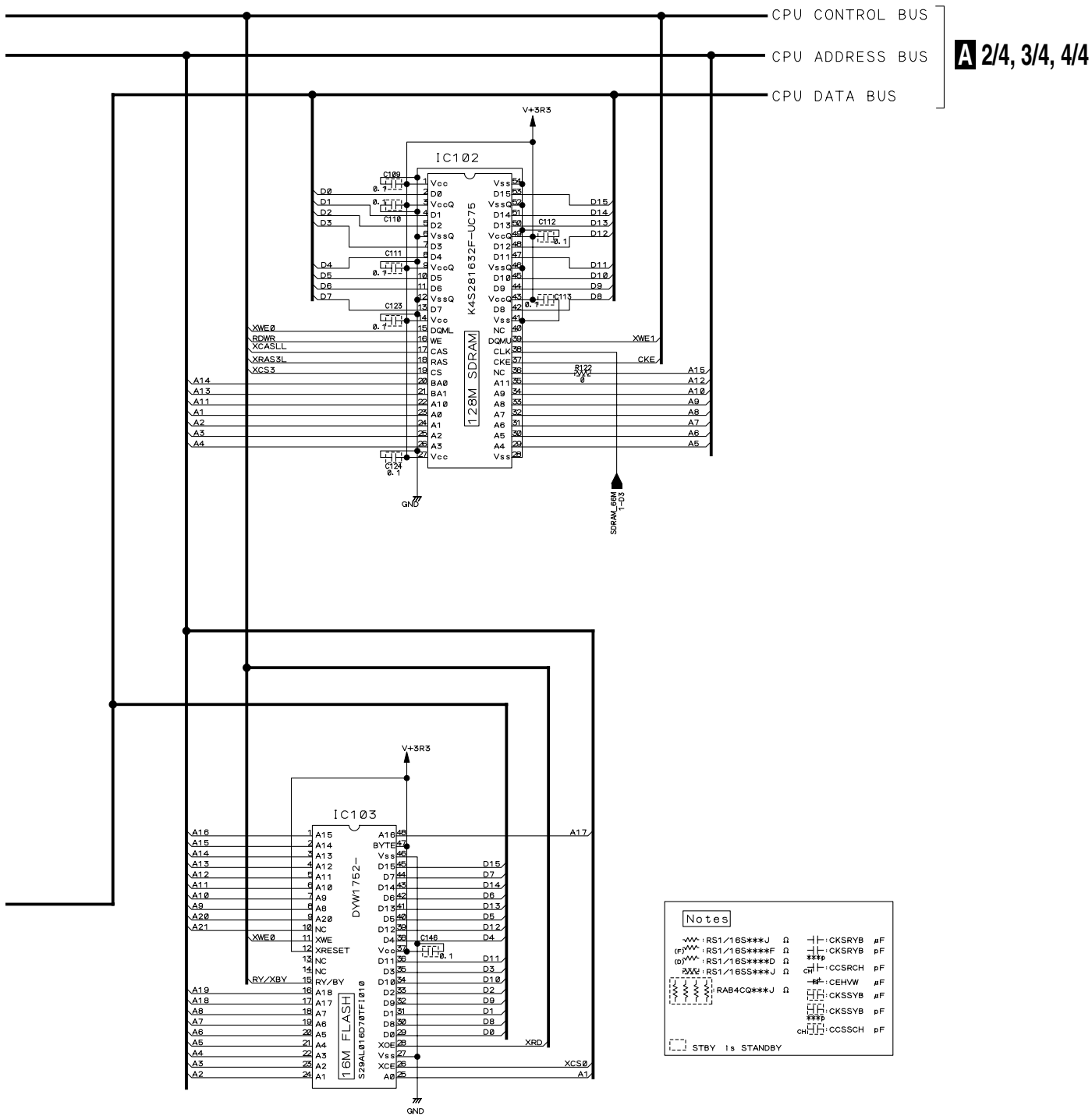

3.4 MAIN ASSY (2/4)

A 2/4 MAIN ASSY (DWG1591)

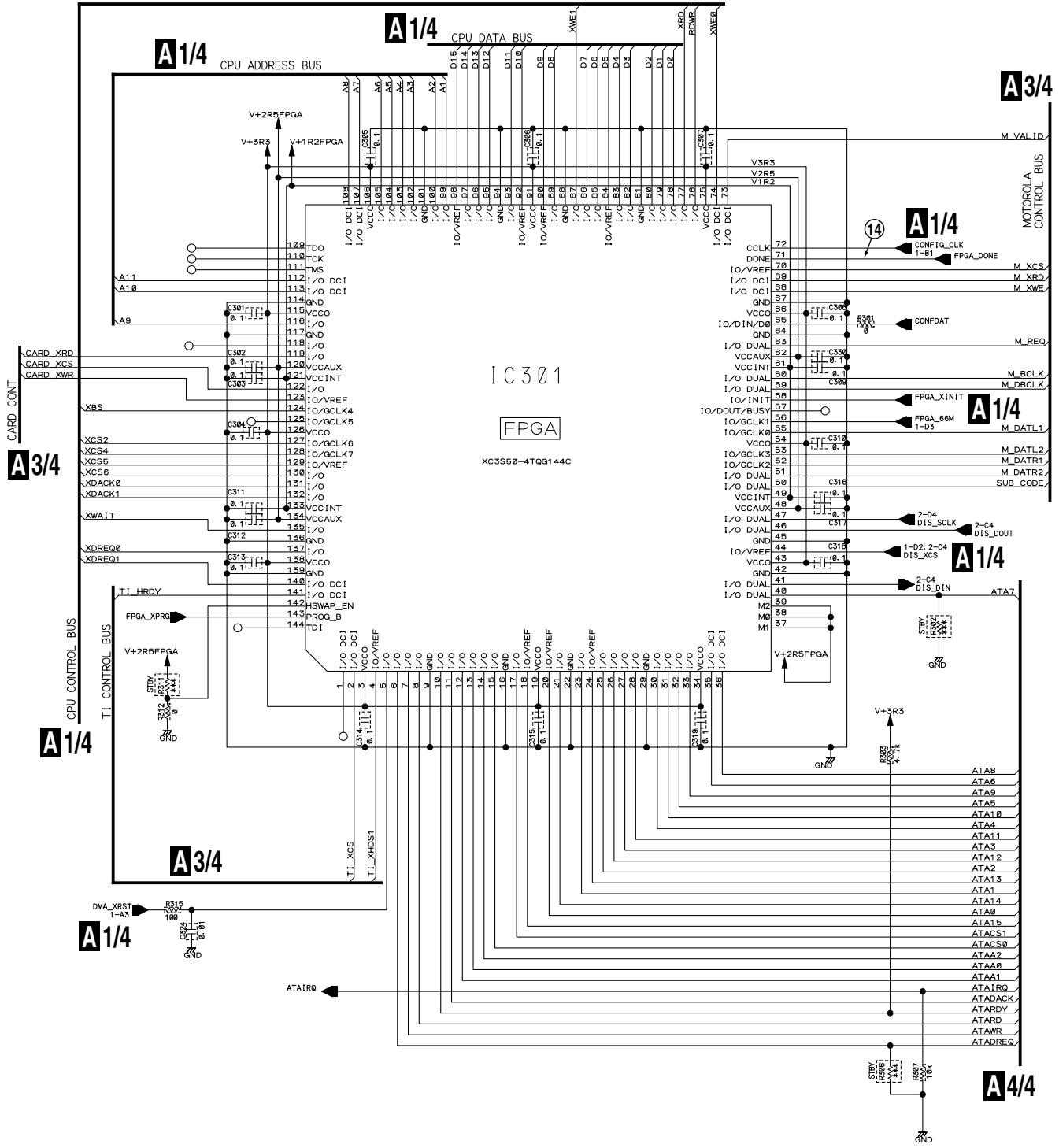
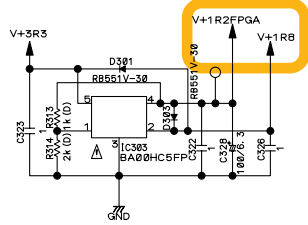
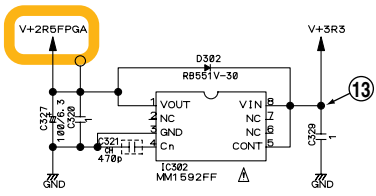

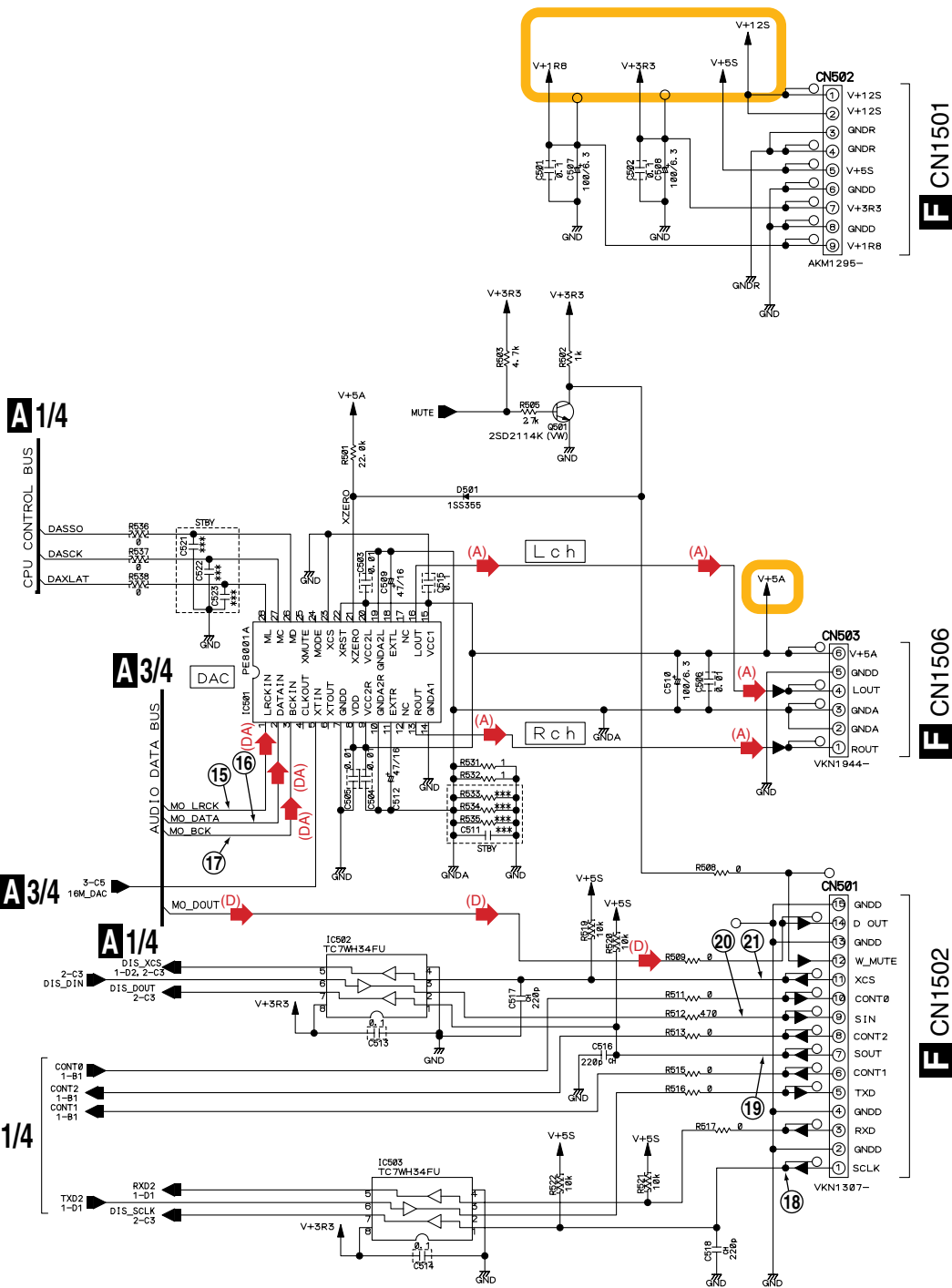

A 1/4

A 3/4

A 3/4

A 1/4

A 1/4

F CN1501

F CN1506

F CN1502

Notes	
RS1/16S***J	CKSRYB #F
RS1/16S****F	CKSRYB pF
RS1/16S****D	CCSRCH pF
RS1/16S***J	CEHW #F
RAB4CQ***J	CKSSYB #F
	CKSSYB pF
	CCSSCH pF
STBY 1s STANDBY	

- (DA) : Audio Data Signal Route
- (A) : Analog Audio Signal Route
- (D) : Digital Out Signal Route

A 2/4

3.5 MAIN ASSY (3/4)

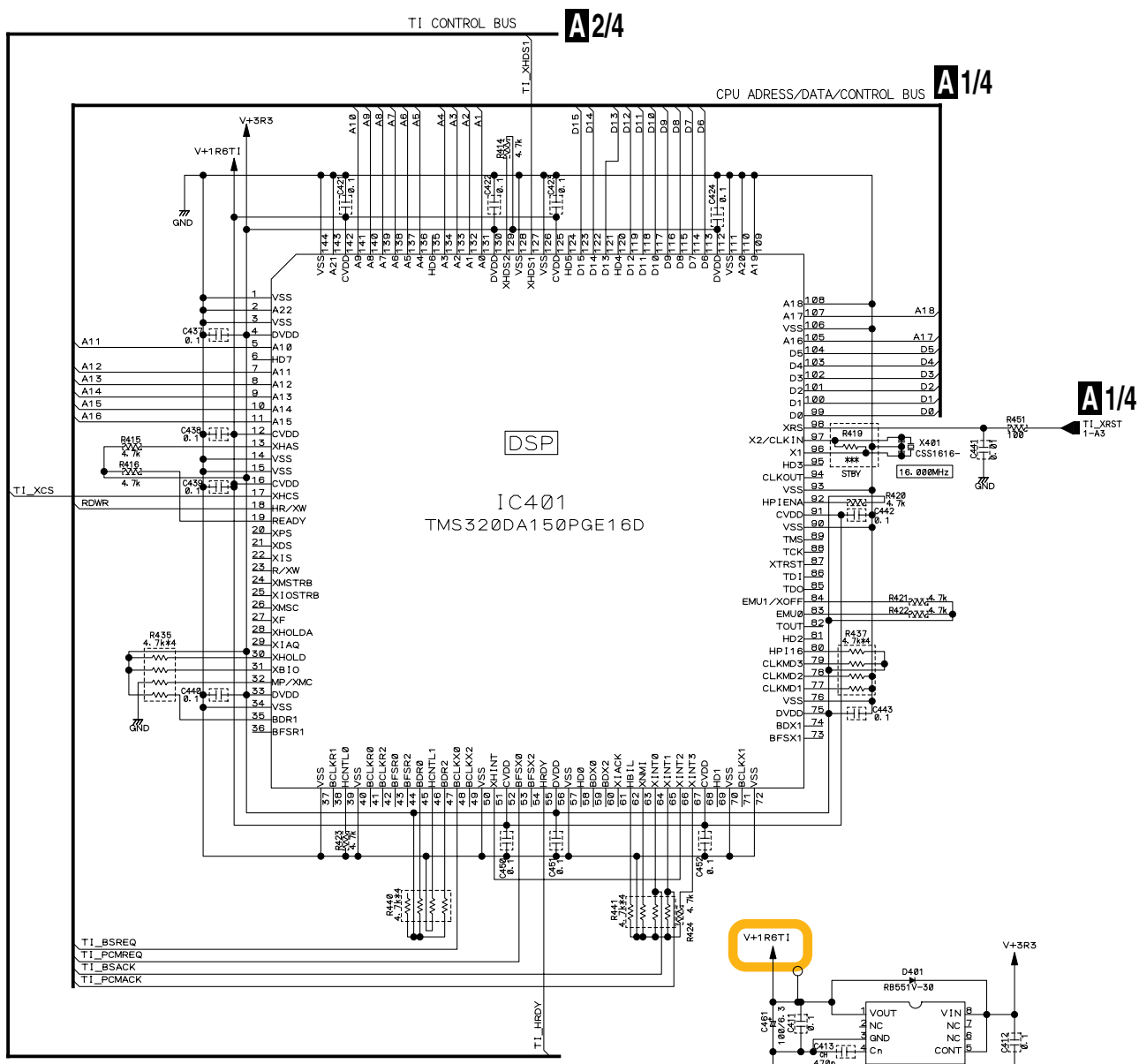
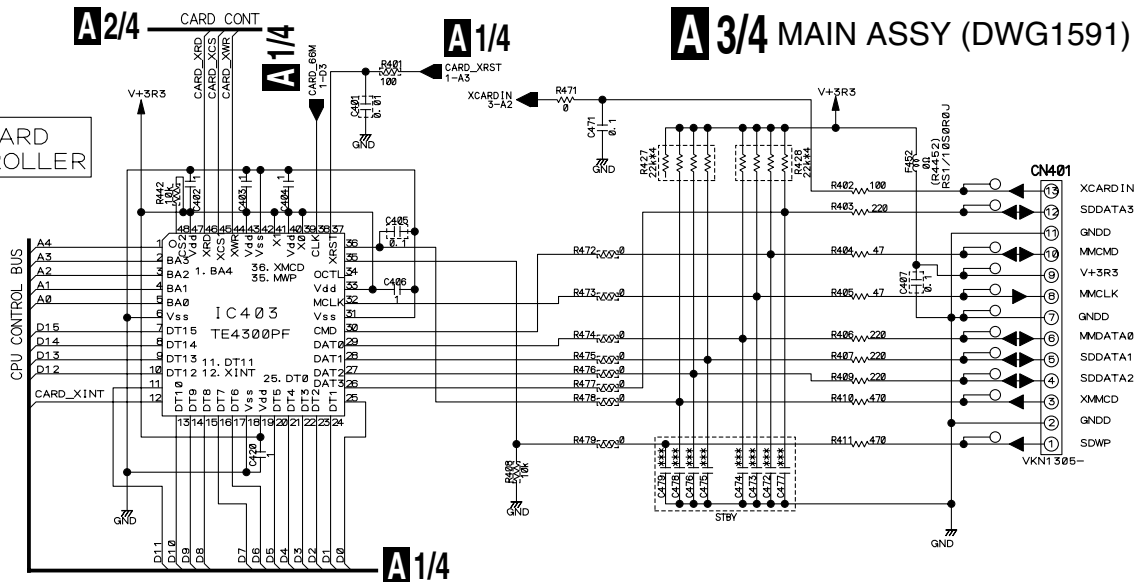

A 3/4

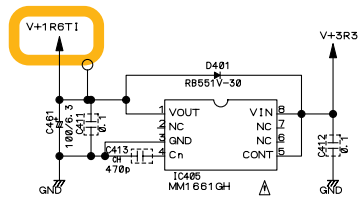

A1/4

CPU ADDRESS/DATA/CONTROL BUS

A2/4

MOTOROLA CONTROL BUS

A2/4

AUDIO DATA BUS

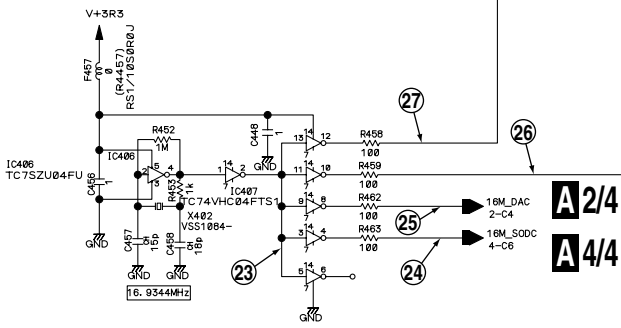
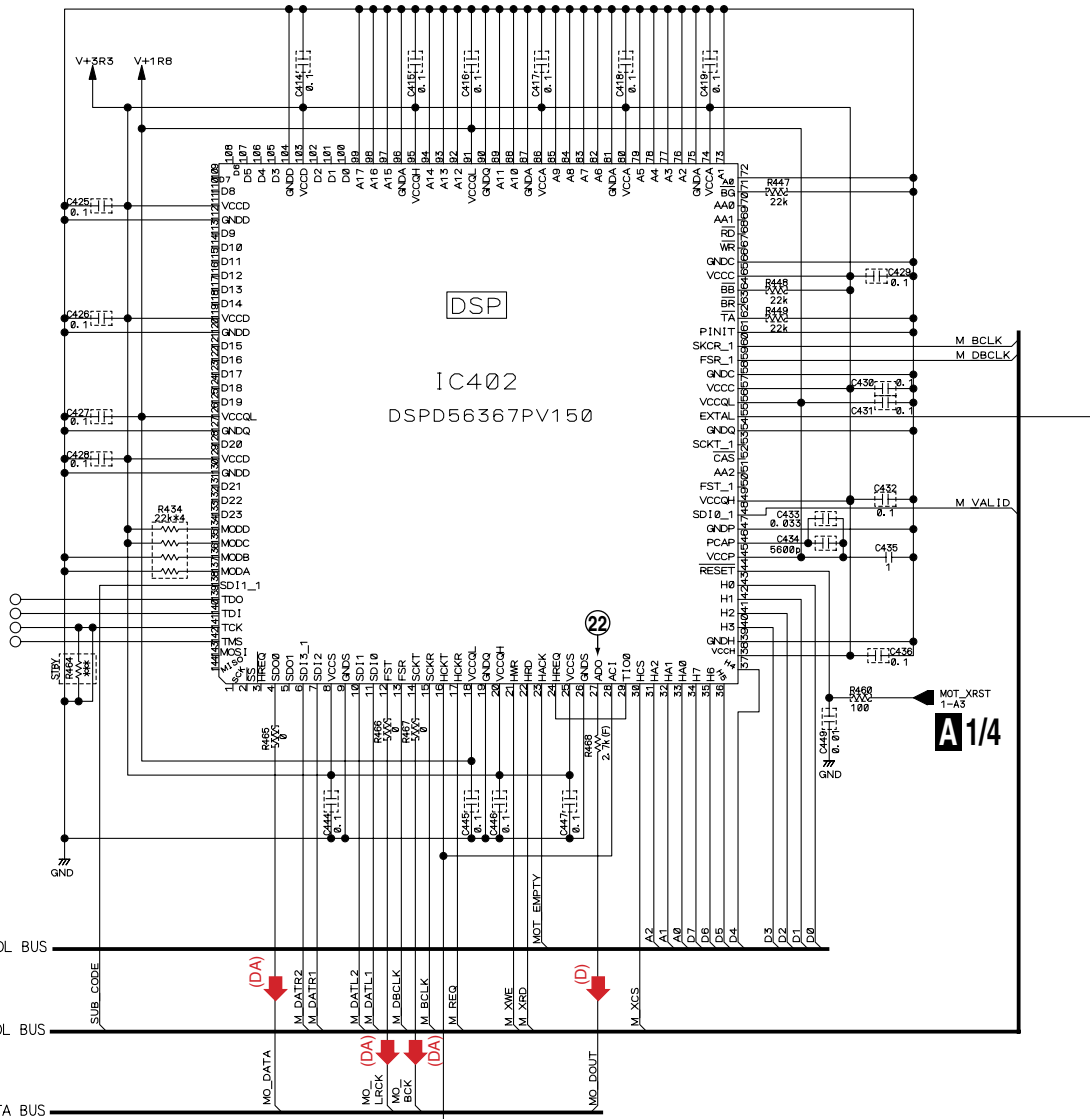

Notes	
RS1/16S***J	CKSRYB #F
(P) RS1/16S***F	CKSRYB pF
(O) RS1/16S***D	***
RS1/16S***J	CCSRCH pF
RAB4CQ***J	CEHW #F
	CKSSYB #F
	CKSSYB pF
	CCSSCH pF
STBY 1s STANDBY	

(DA) : Audio Data Signal Route
 (D) : Digital Out Signal Route

A 3/4

3.6 MAIN (4/4) and SLMB ASSYS

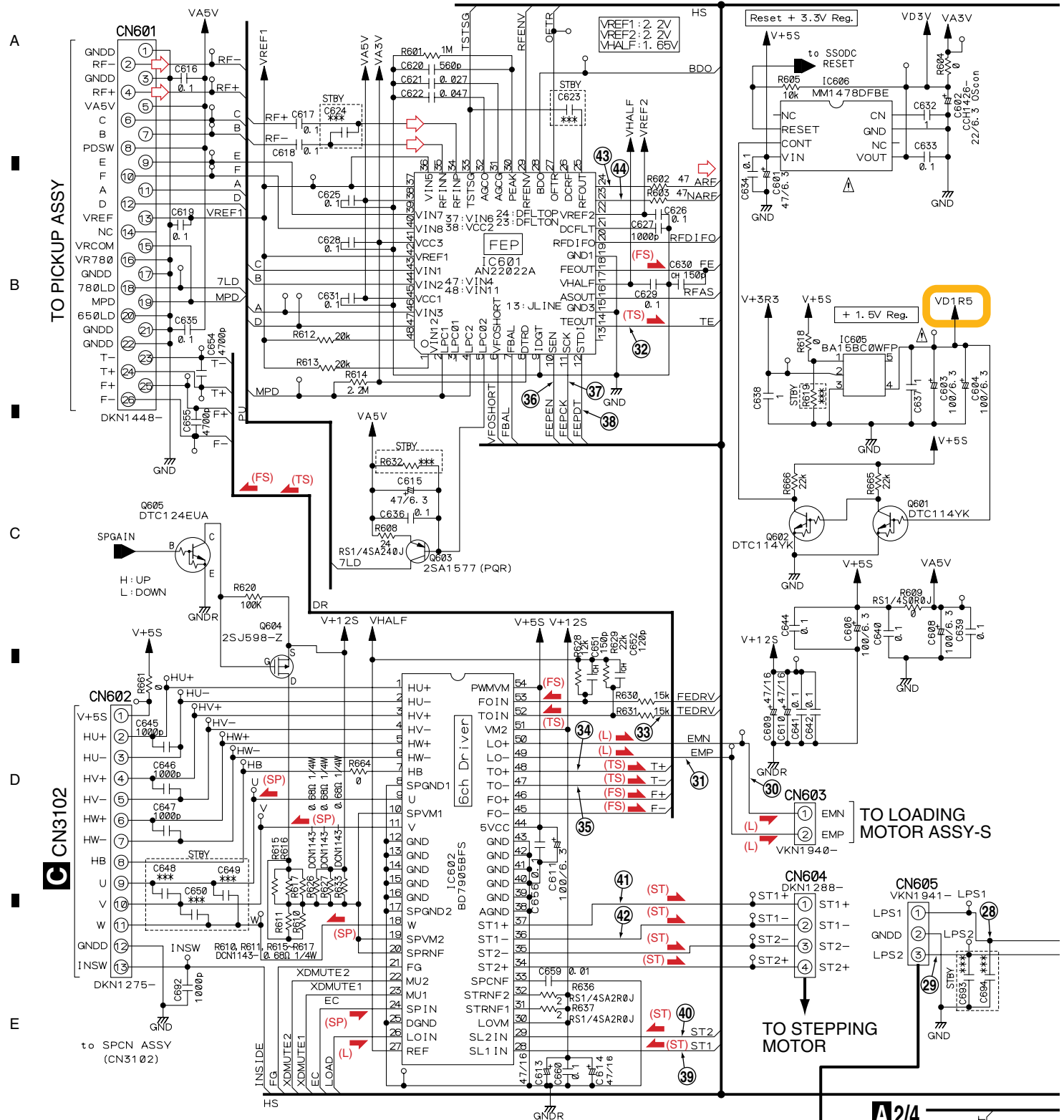

Notes

W	RS1/16S***J	Ω		CKSRYB	μF
(F)	RS1/16S***F	Ω		CKSRYB	pF
(D)	RS1/16S***D	Ω		CCSRCH	pF
XXX	RS1/16SS***J	Ω		CEHVV	μF
	RAB4CQ***J	Ω		CKSSYB	μF
				CKSSYB	pF
				CCSSCH	pF

STBY is STANDBY

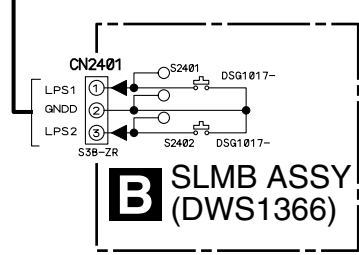

TO PICKUP ASSY

TO LOADING MOTOR ASSY-S

TO STEPPING MOTOR

A 4/4 B

A2/4

A1/4

A 4/4 MAIN ASSY (DWG1591)

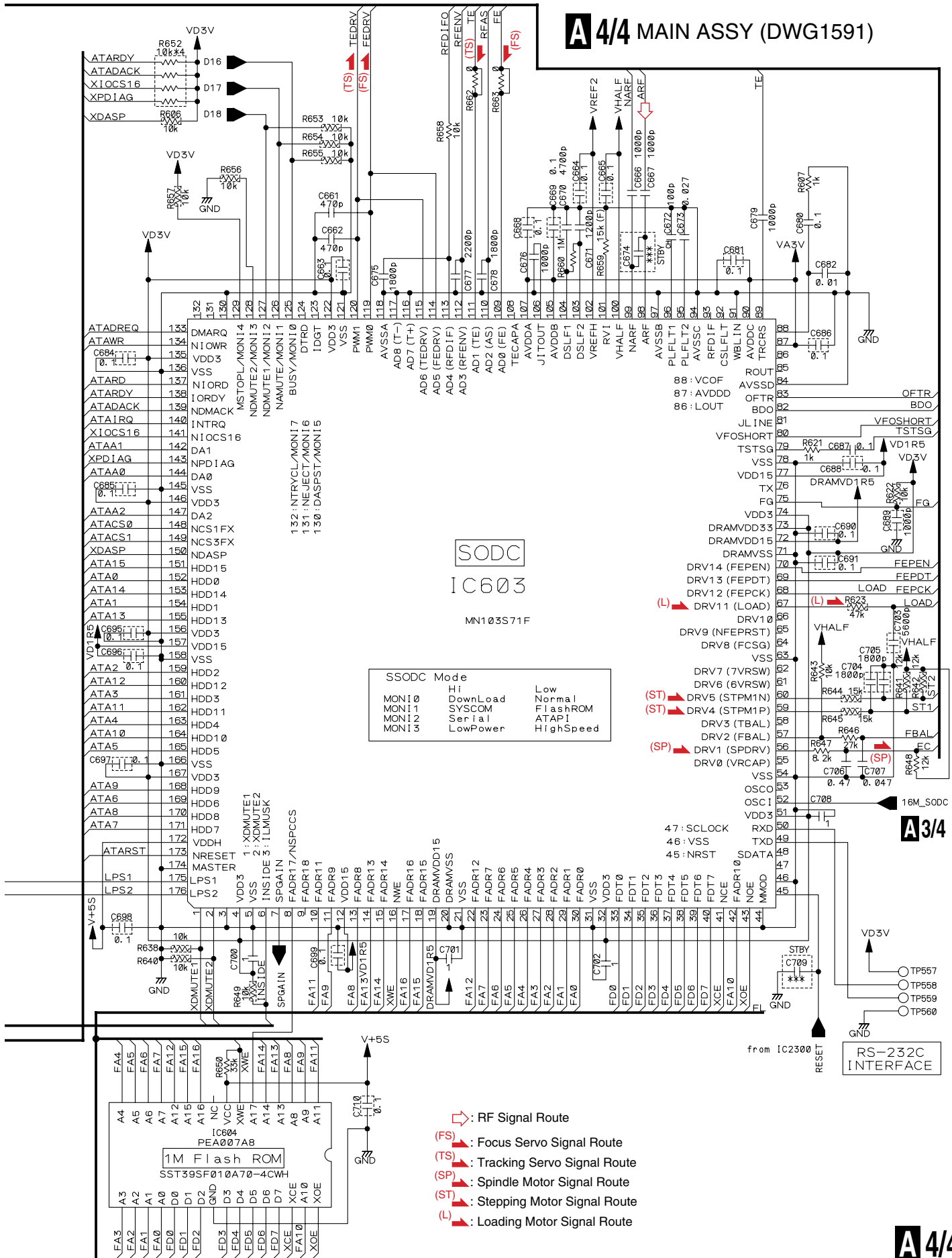

- ⇨ RF Signal Route
- ⇨ Focus Servo Signal Route (FS)
- ⇨ Tracking Servo Signal Route (TS)
- ⇨ Spindle Motor Signal Route (SP)
- ⇨ Stepping Motor Signal Route (ST)
- ⇨ Loading Motor Signal Route (L)

A 4/4

CDJ-1000MK3

3.7 SPCN, INSW and SDCB ASSYS

A
B
C
D
E
F

A 4/4
CN602

C SPCN ASSY (DWX2559)

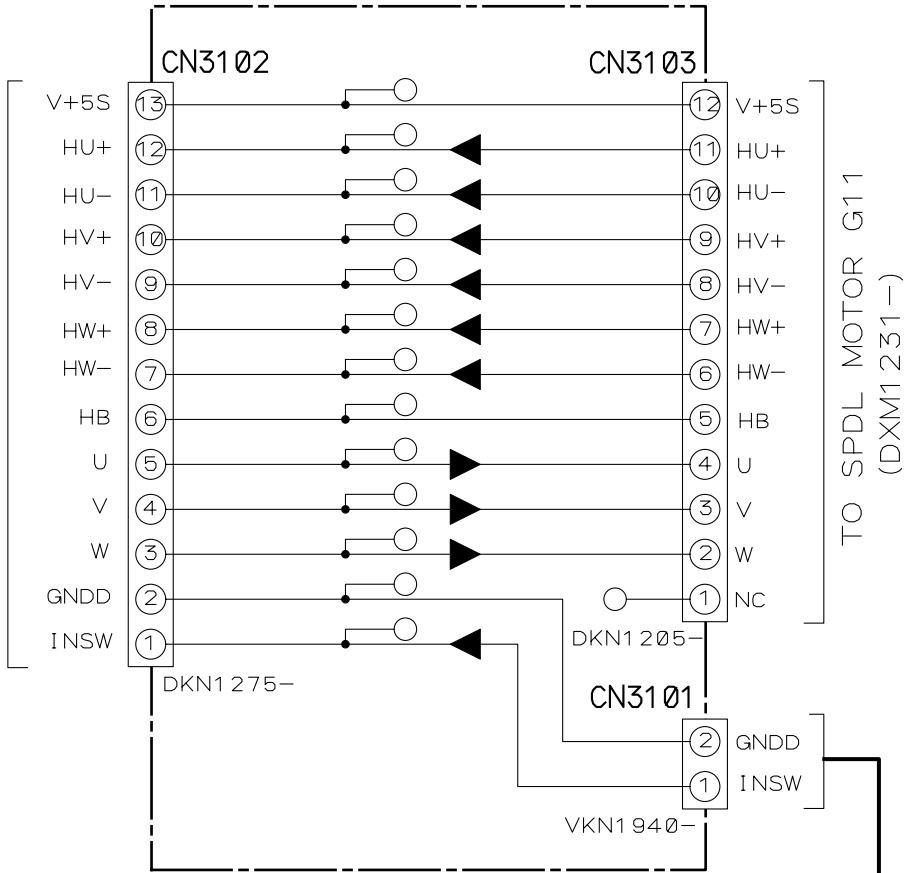

TO SPDL MOTOR G11
(DXM1231-)

D INSW ASSY (DWS1369)

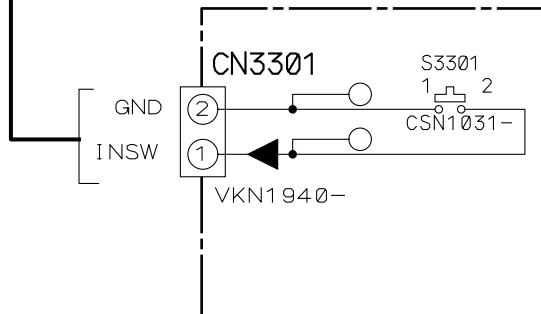

Notes

⎓ : RS1/16S***J Ω

⎓ : CKSRYB μF

⎓ STBY is STANDBY

C D

SDCB ASSY (DWX2558)

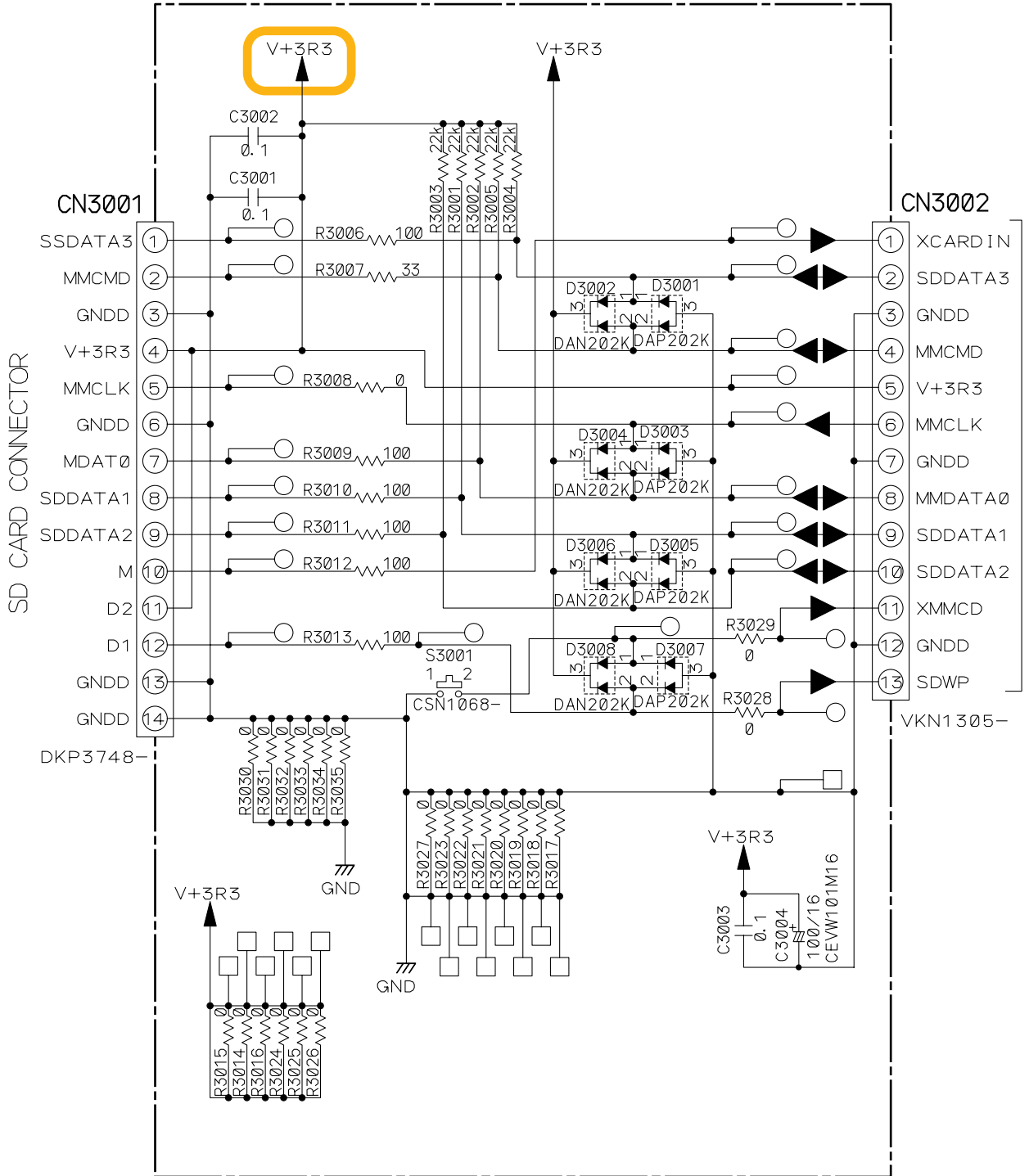

A 3/4 CN401

3.8 MJCB ASSY

1

2

3

4

F MJCB ASSY (DWG1605)

J CN2002

B

C

D

E

F

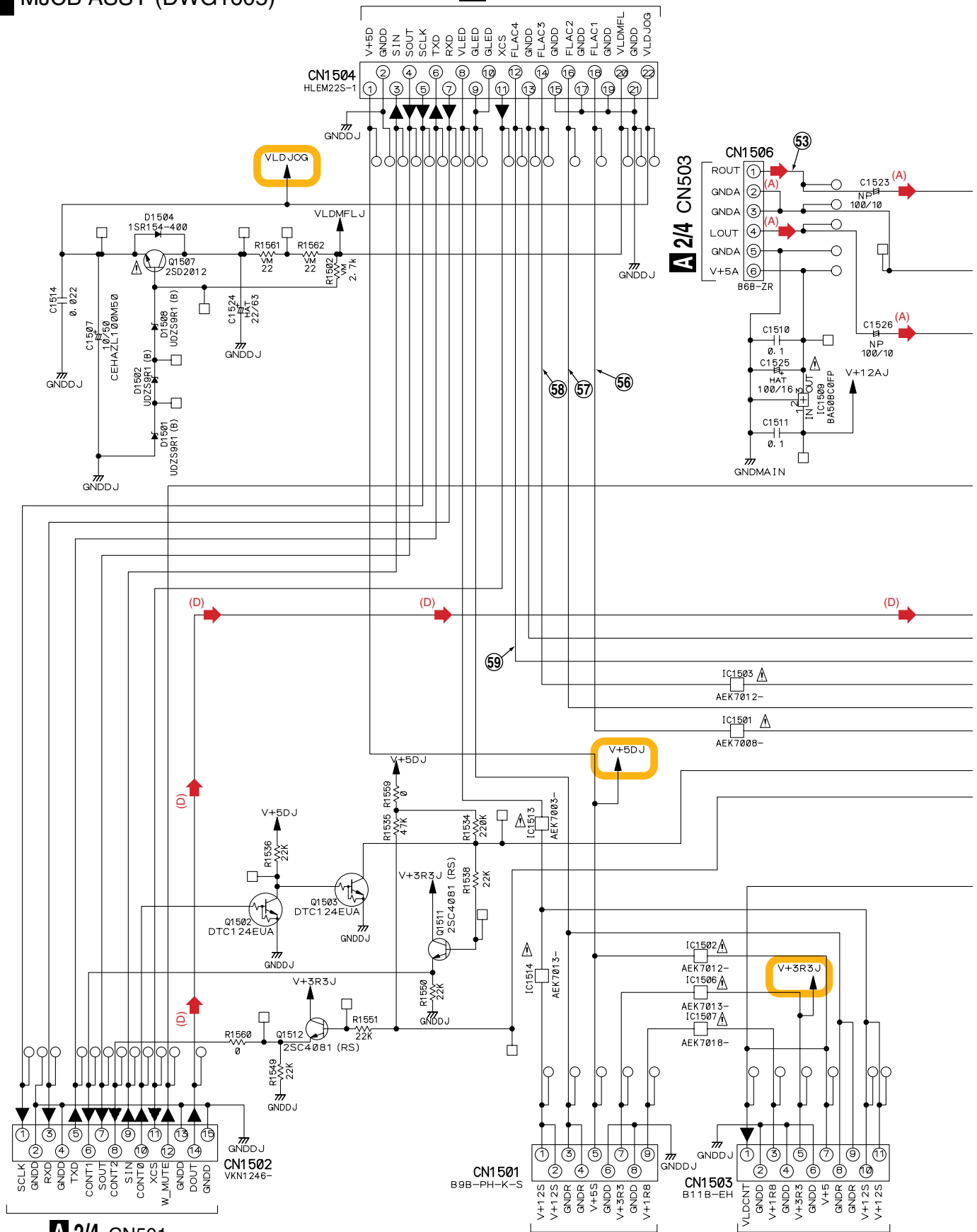

A 2/4 CN501

A 2/4 CN502

M CN201

F

1

2

3

4

CAUTION : FOR CONTINUED PROTECTION AGAINST RISK OF FIRE. REPLACE ONLY WITH SAME TYPE NO. AEK7008- 491.800 MFD, BY LITTELFUSE INK. FOR IC1501.

CAUTION : FOR CONTINUED PROTECTION AGAINST RISK OF FIRE. REPLACE ONLY WITH SAME TYPE NO. AEK7023- 491.200 MFD, BY LITTELFUSE INK. FOR IC1504.

CAUTION : FOR CONTINUED PROTECTION AGAINST RISK OF FIRE. REPLACE ONLY WITH SAME TYPE NO. AEK7013- 4910002. MFD, BY LITTELFUSE INK. FOR IC1506 AND IC1514.

CAUTION : FOR CONTINUED PROTECTION AGAINST RISK OF FIRE. REPLACE ONLY WITH SAME TYPE NO. AEK7012- 49101.6 MFD, BY LITTELFUSE INK. FOR IC1502 AND IC1503.

CAUTION : FOR CONTINUED PROTECTION AGAINST RISK OF FIRE. REPLACE ONLY WITH SAME TYPE NO. AEK7018- 4910004. MFD, BY LITTELFUSE INK. FOR IC1507.

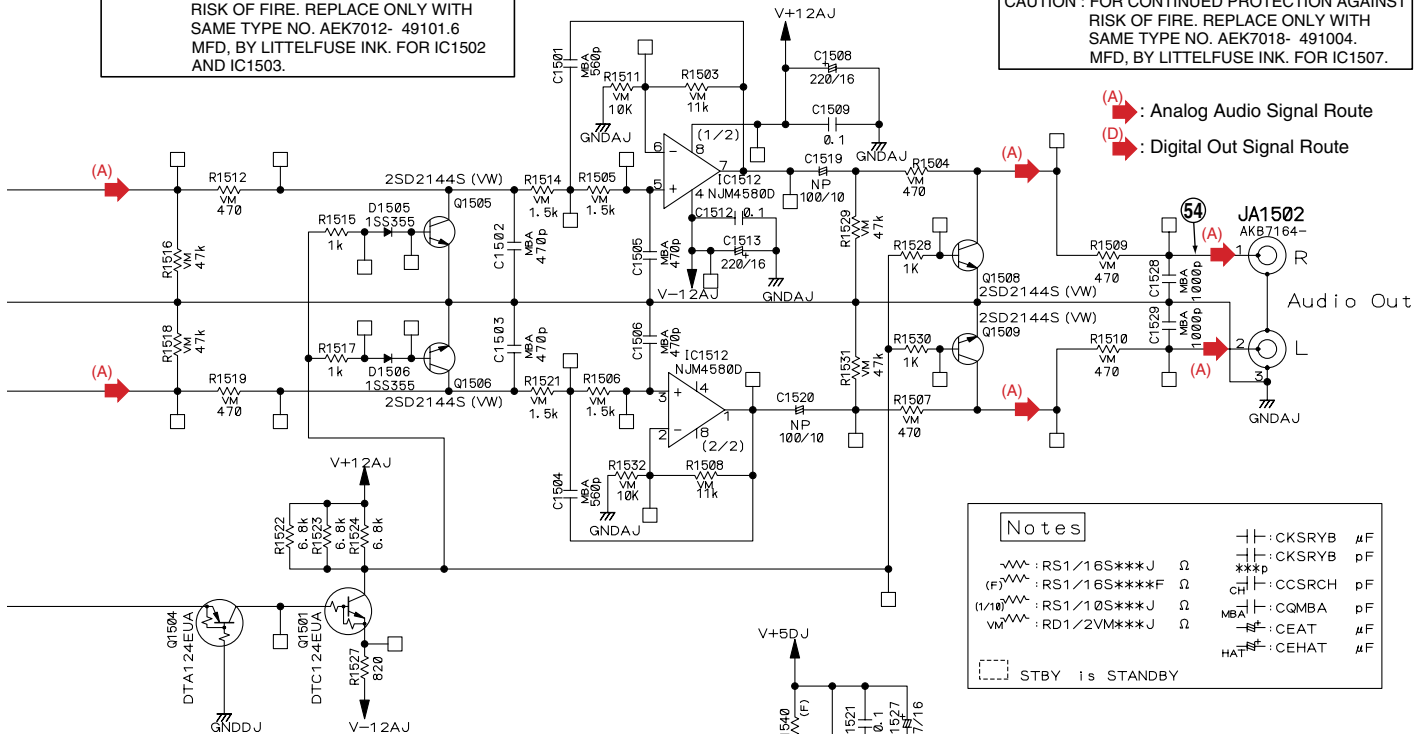

(A) : Analog Audio Signal Route
(D) : Digital Out Signal Route

Notes

⎓	: RS1/16S***J	Ω	⎓	: CKSRYB	μF
(F)⎓	: RS1/16S****F	Ω	⎓	: CKSRYB	pF
(1/10)⎓	: RS1/10S***J	Ω	⎓	: CGMBA	pF
⎓	: RD1/2VM***J	Ω	⎓	: CEAT	μF
			⎓	: CEHAT	μF

STBY is STANDBY

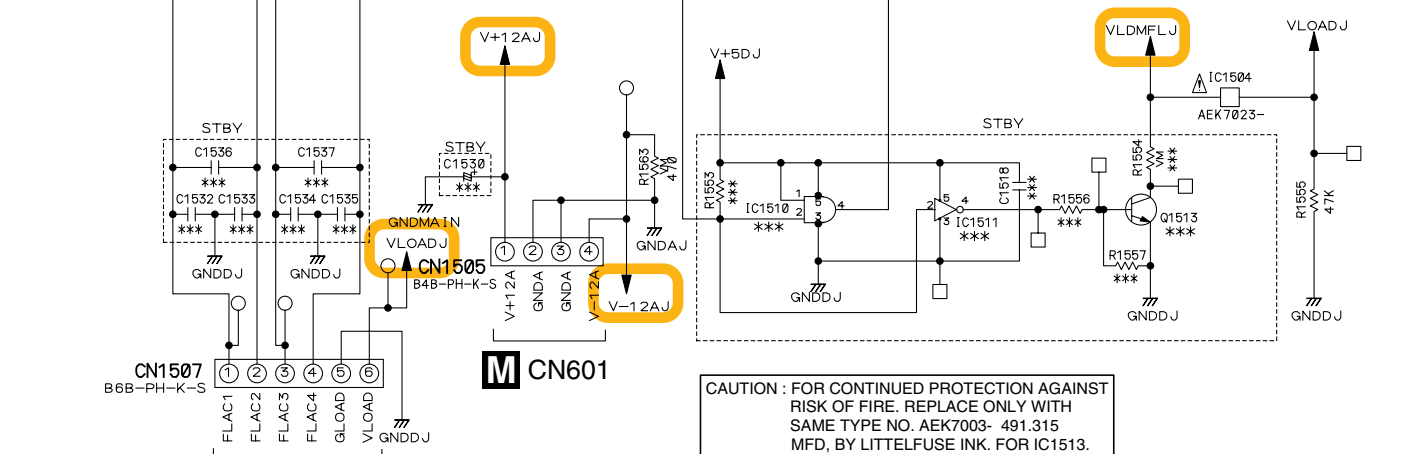
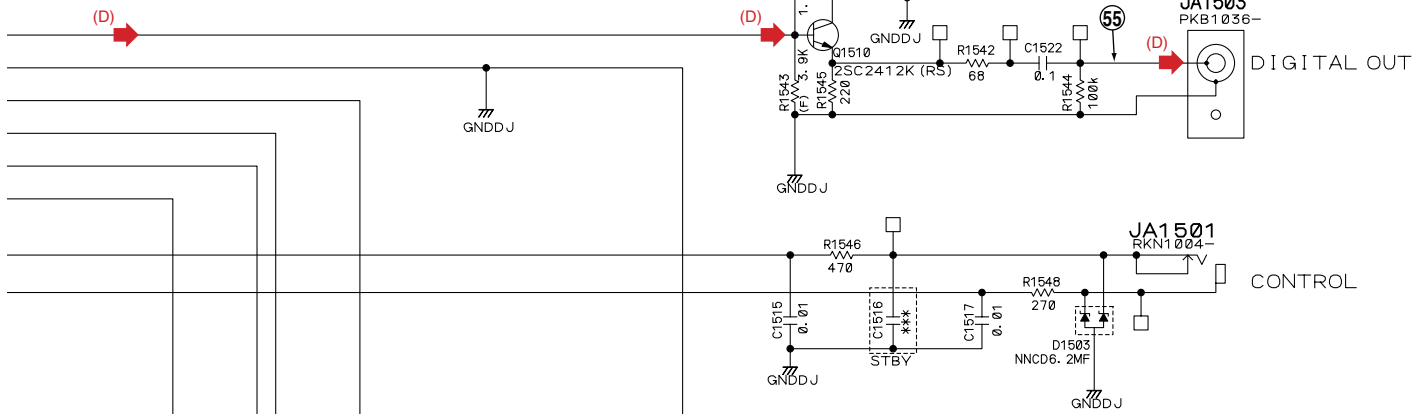

CAUTION : FOR CONTINUED PROTECTION AGAINST RISK OF FIRE. REPLACE ONLY WITH SAME TYPE NO. AEK7003- 491.315 MFD, BY LITTELFUSE INK. FOR IC1513.

M CN301

M CN601

CN1507
86B-PH-K-S

CN1505
84B-PH-K-S

F

3.9 MFLB ASSY

MFLB ASSY (DWG1606)

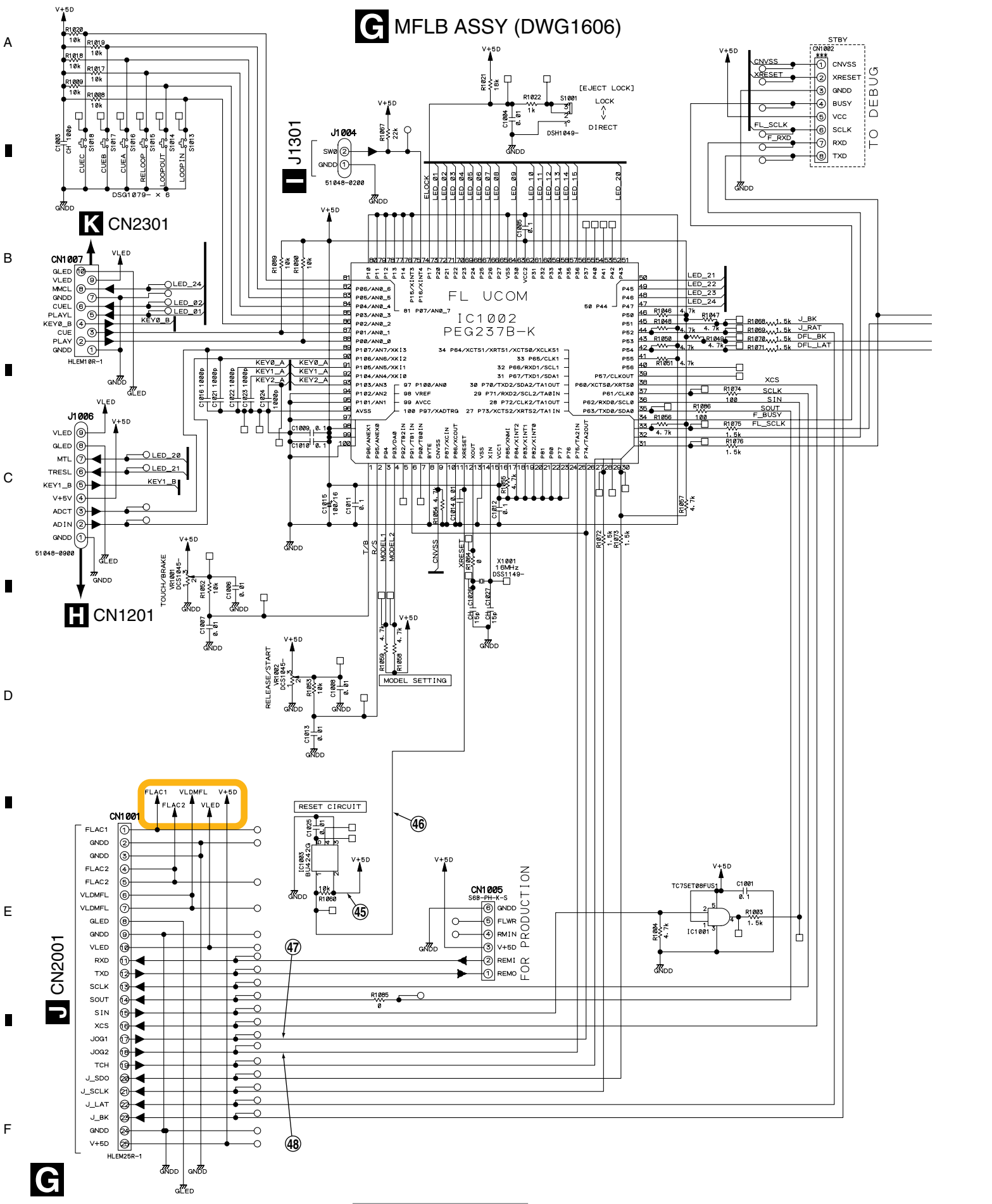

3.10 SLDB and RSWB ASSYS

A
B
C
D
E
F

G J1006

H SLDB ASSY (DWS1367)

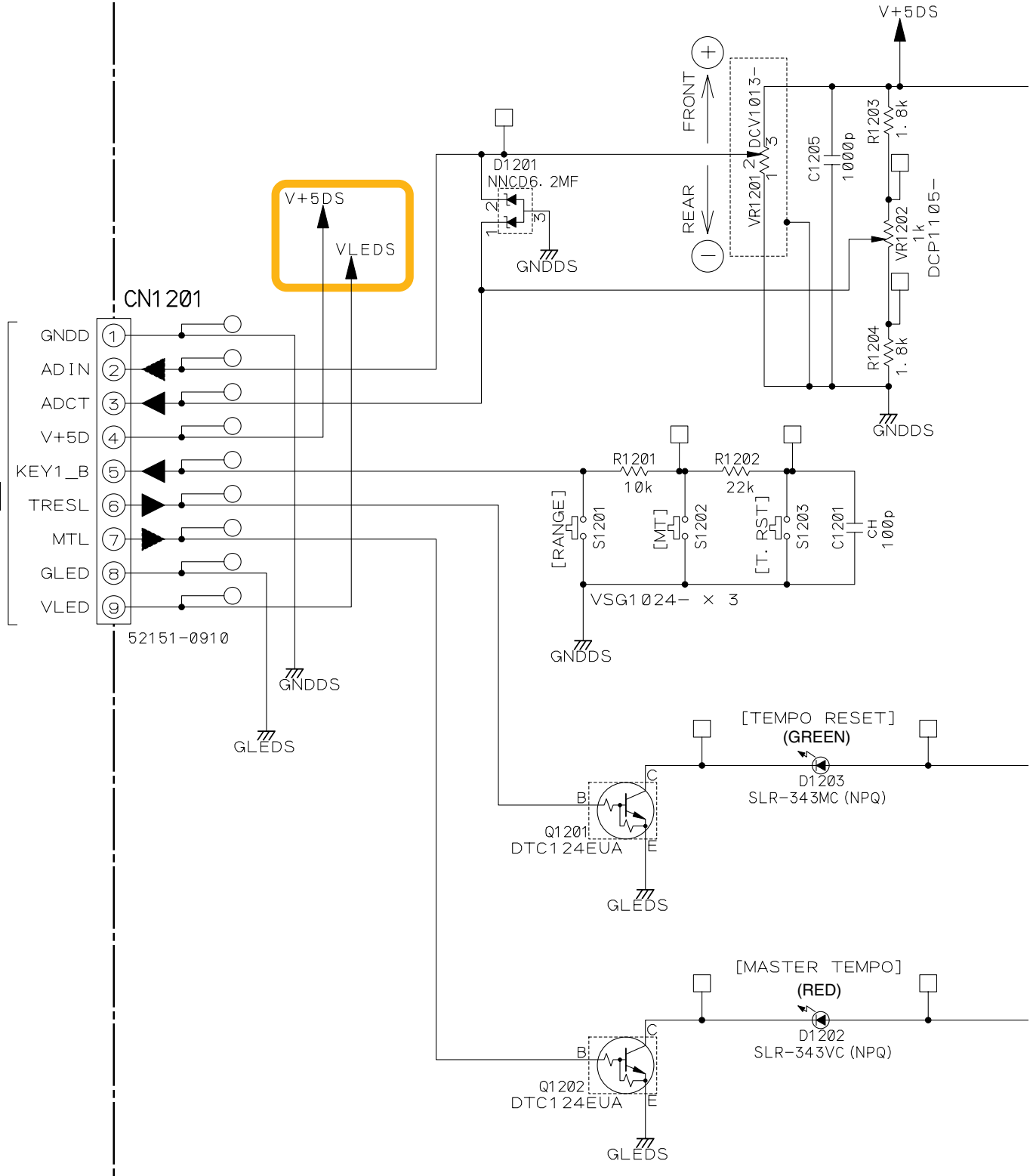

H

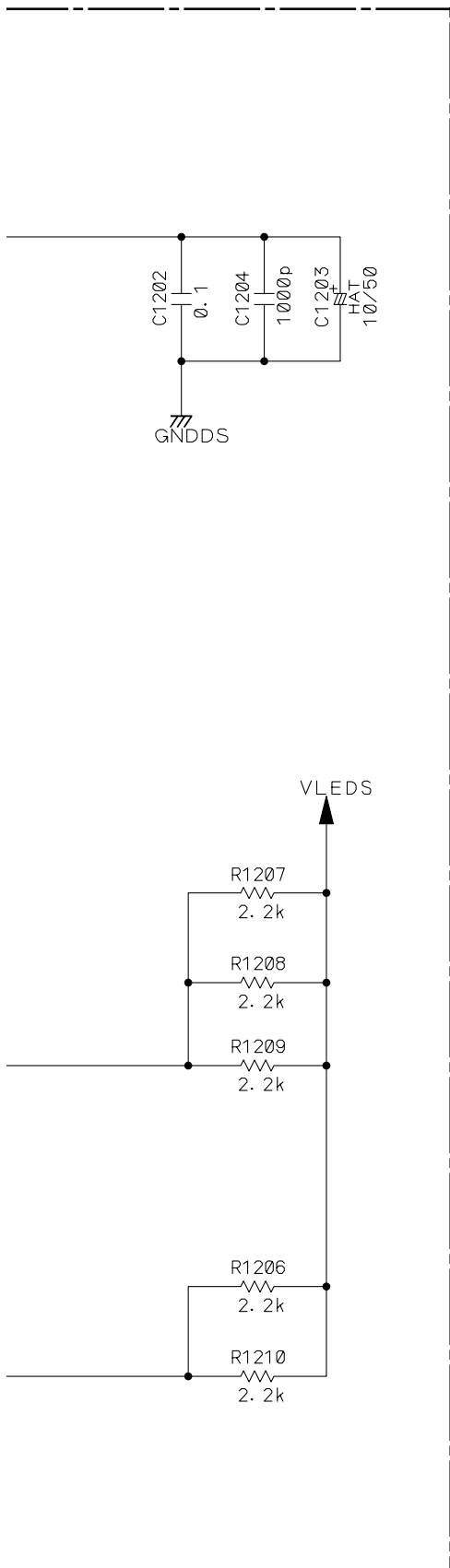

Notes

	: RS1/16S***J	Ω		: CKSRYB	μF	
(F)	: RS1/16S***F	Ω		: CKSRYB	pF	
(1/10)	: RS1/10S***J	Ω		: ***p		
VM	: RD1/2VM***J	Ω		: CH	: CCSRCH	pF
				: MBA	: CQ MBA	pF
				: CEAT		μF
				: HAT	: CEHAT	μF

STBY is STANDBY

RSWB ASSY (DWS1368)

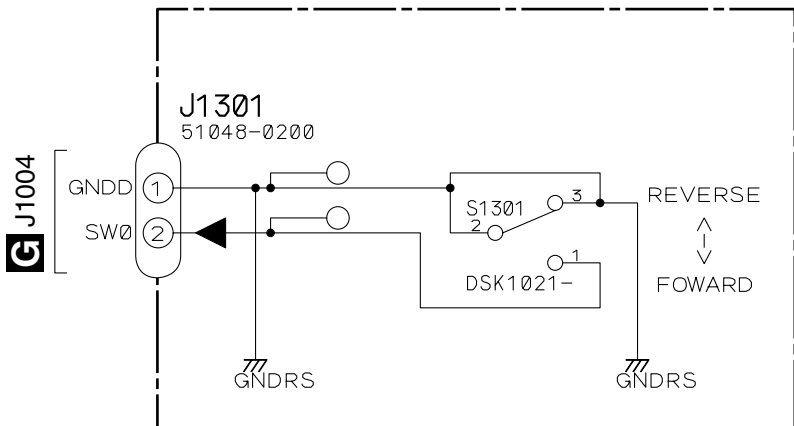

3.11 JFLB, KSWB and JOGB ASSYS

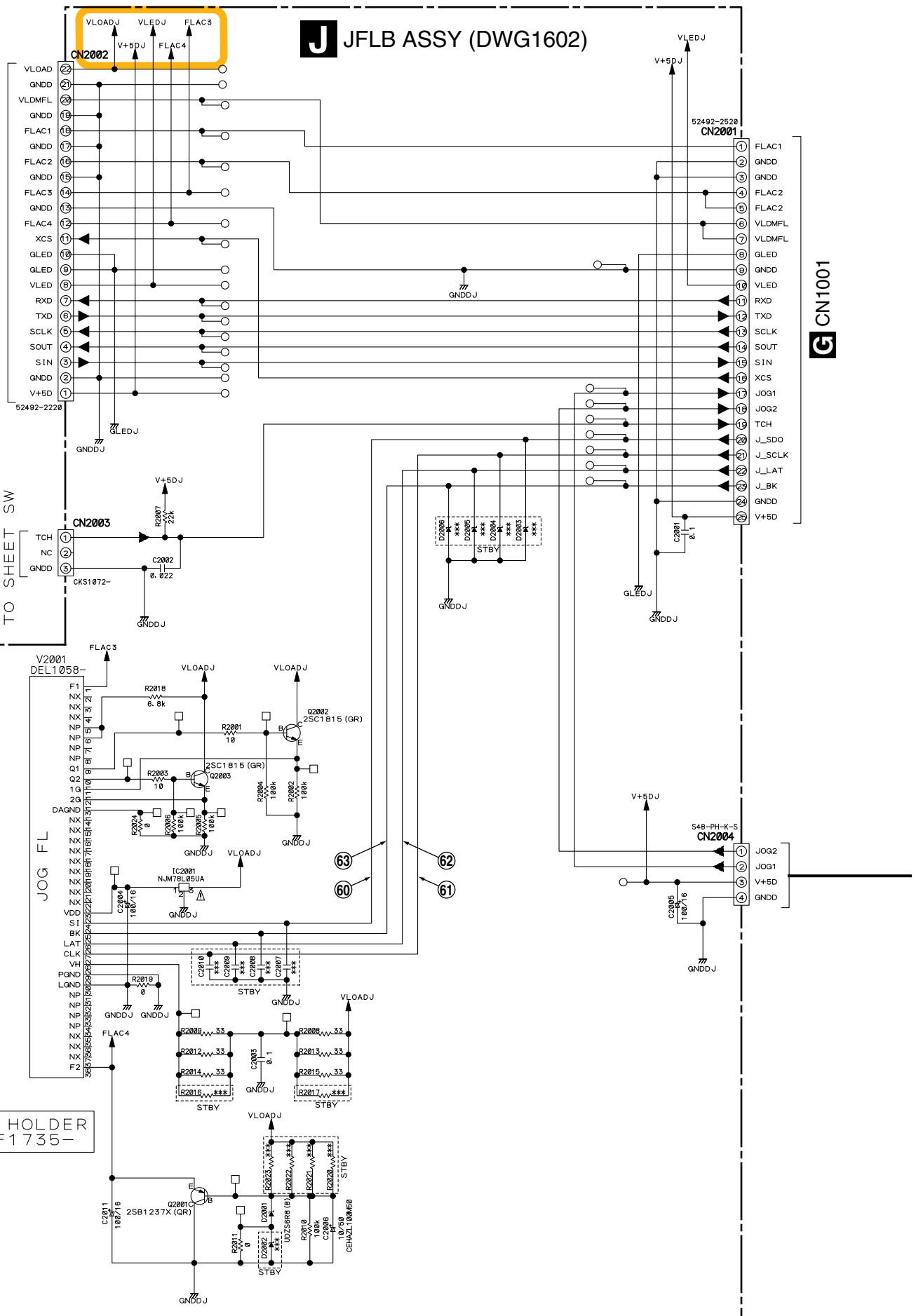

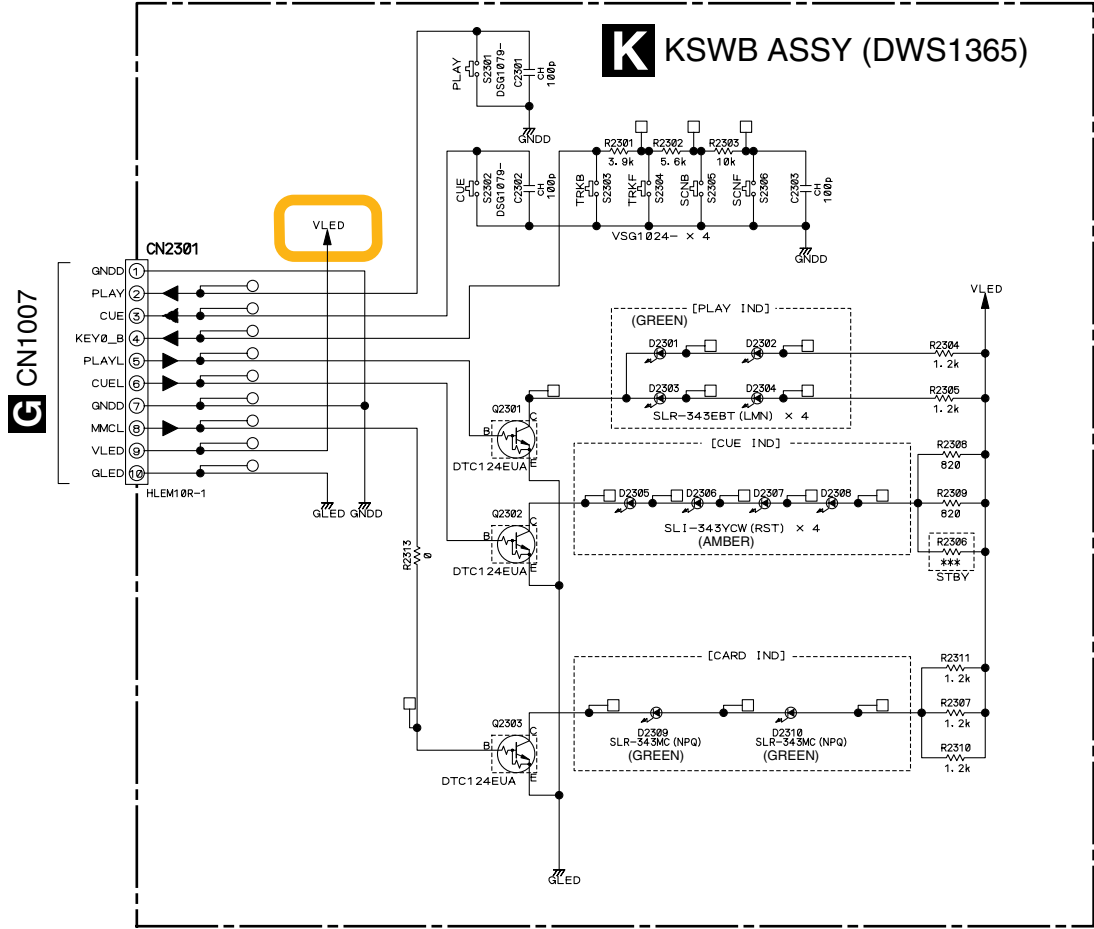

L JOGB ASSY (DWG1603)

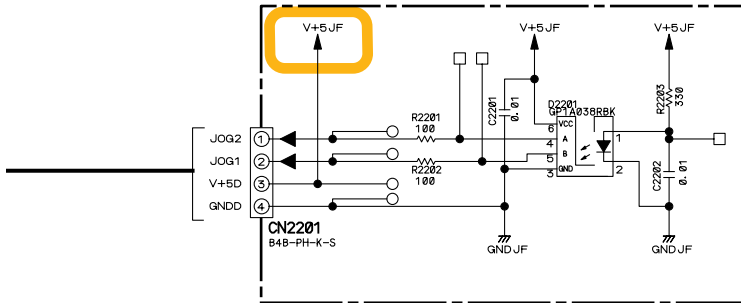

Notes	
RS1/16S***J	Ω
CKSRYB	#F
CCSRCH	pF
CEHAT	#F
STBY	is STANDBY

3.12 SW POWER SUPPLY ASSY

1

2

3

4

A M SW POWER SUPPLY ASSY (DWR1409)

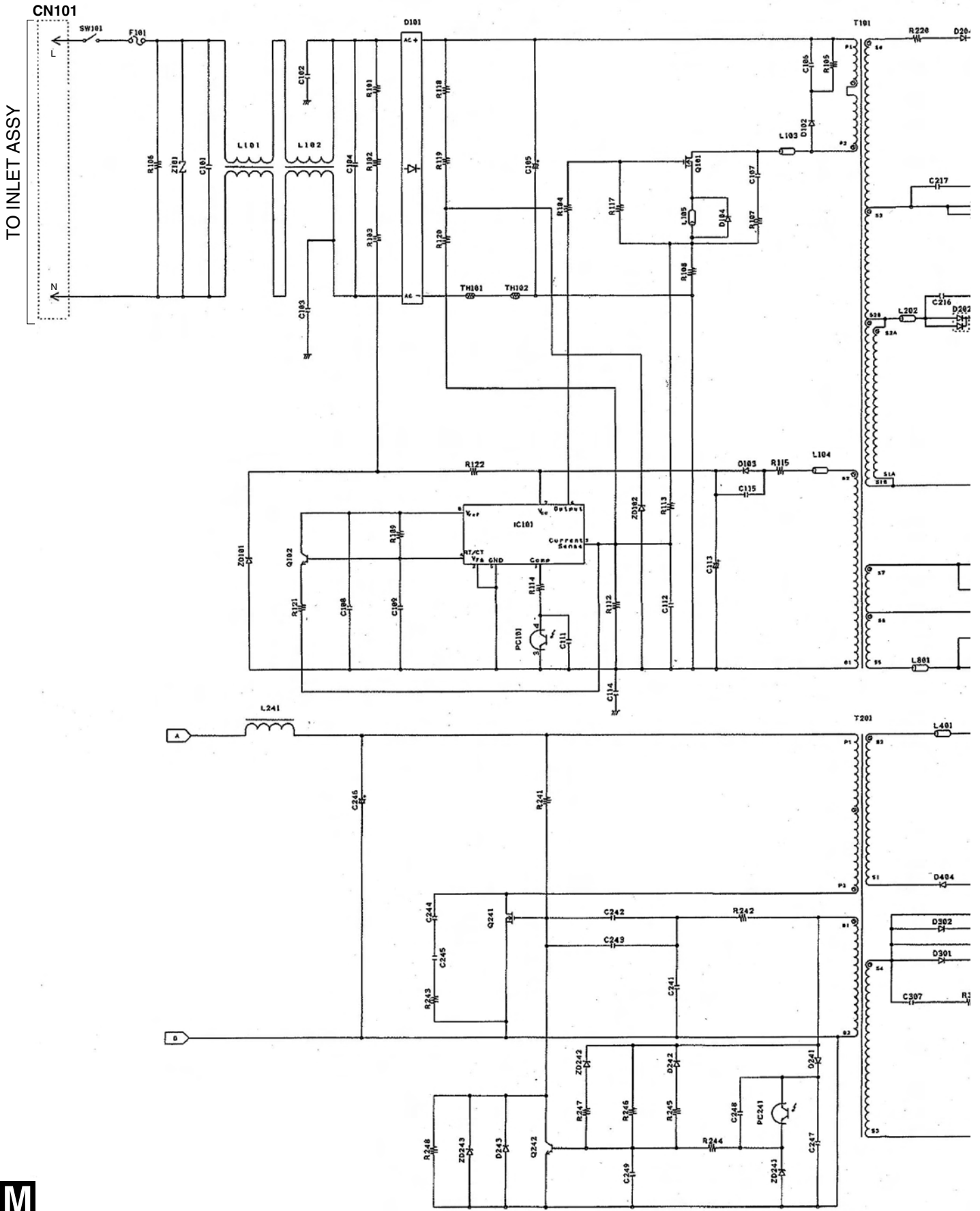

F



1

2

3

4

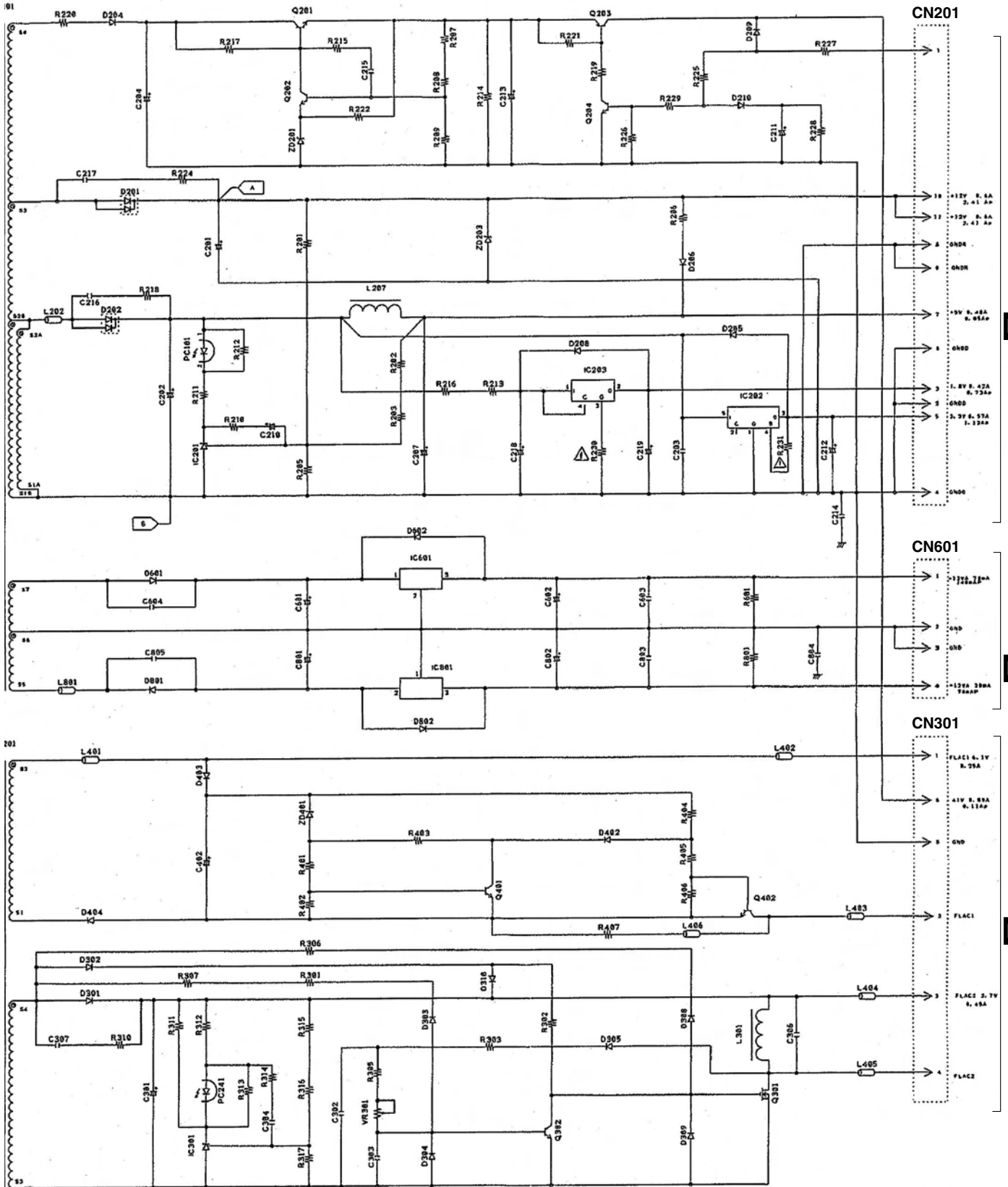

A
B
C
D
E
F

F CN1503

F CN1505

F CN1507



3.13 WAVEFORMS

WAVEFORMS

Note : The encircled numbers denote measuring point in the schematic diagram and pcb diagram.

<p>A 1/4 MAIN ASSY Mode: Power ON</p> <p>① IC104 - 2 pin (V+3R3) V: 2V/div. H: 100mS/div.</p> <p>② IC104 - 1 pin (RSTCPU) V: 2V/div. H: 100mS/div.</p>	<p>A 1/4 MAIN ASSY Mode: Power ON</p> <p>② IC104 - 1 pin (RSTCPU) V: 2V/div. H: 500mS/div.</p> <p>⑥ IC114 - 6 pin (MOT_XRST) V: 2V/div. H: 500mS/div.</p>	<p>A 1/4 MAIN ASSY Mode: PLAY</p> <p>⑩ IC107 - 6 pin (SH_66M) V: 0.5V/div. H: 5nS/div.</p>	<p>A 2/4 MAIN ASSY Mode: PLAY (1kHz, 0dB)</p> <p>⑮ IC501 - 1 pin (MO_LRCK) V: 2V/div. H: 5μS/div.</p> <p>⑯ IC501 - 2 pin (MO_DATA) V: 2V/div. H: 5μS/div.</p> <p>⑰ IC501 - 3 pin (MO_BCK) V: 2V/div. H: 5μS/div.</p>
<p>A 1/4 MAIN ASSY Mode: Power ON</p> <p>② IC104 - 1 pin (RSTCPU) V: 2V/div. H: 500mS/div.</p> <p>③ IC114 - 10 pin (DMA_XRST) V: 2V/div. H: 500mS/div.</p>	<p>A 1/4 MAIN ASSY Mode: Power ON</p> <p>② IC104 - 1 pin (RSTCPU) V: 2V/div. H: 500mS/div.</p> <p>⑦ IC114 - 12 pin (ATARST) V: 2V/div. H: 500mS/div.</p>	<p>A 1/4 MAIN ASSY Mode: PLAY</p> <p>⑪ IC107 - 8 pin (SDRAM_66M) V: 0.5V/div. H: 5nS/div.</p>	<p>A 2/4 MAIN ASSY Mode: PLAY</p> <p>⑱ CN501 - 1 pin (SCLK) V: 5V/div. H: 20μS/div.</p> <p>⑲ CN501 - 7 pin (SOUT) V: 5V/div. H: 20μS/div.</p> <p>⑳ CN501 - 9 pin (SIN) V: 5V/div. H: 20μS/div.</p> <p>㉑ CN501 - 11 pin (XCS) V: 5V/div. H: 20μS/div.</p>
<p>A 1/4 MAIN ASSY Mode: Power ON</p> <p>② IC104 - 1 pin (RSTCPU) V: 2V/div. H: 500mS/div.</p> <p>④ IC114 - 8 pin (CARD_XRST) V: 2V/div. H: 500mS/div.</p>	<p>A 1/4 MAIN ASSY Mode: PLAY</p> <p>⑧ IC107 - 3 pin (66MHz CLOCK) V: 0.5V/div. H: 5nS/div.</p>	<p>A 1/4 MAIN ASSY Mode: PLAY</p> <p>⑫ IC107 - 10 pin (FPGA_66M) V: 0.5V/div. H: 5nS/div.</p>	<p>A 3/4 MAIN ASSY Mode: PLAY</p> <p>㉒ IC402 - 27 pin (MO_DOUT) V: 1V/div. H: 200nS/div.</p>
<p>A 1/4 MAIN ASSY Mode: Power ON</p> <p>② IC104 - 1 pin (RSTCPU) V: 2V/div. H: 500mS/div.</p> <p>⑤ IC114 - 4 pin (TI_XRST) V: 2V/div. H: 500mS/div.</p>	<p>A 1/4 MAIN ASSY Mode: PLAY</p> <p>⑨ IC107 - 4 pin (CARD_66M) V: 0.5V/div. H: 5nS/div.</p>	<p>A 2/4 MAIN ASSY Mode: Power ON</p> <p>⑬ IC302 - 8 pin (V+3R3) V: 2V/div. H: 500mS/div.</p> <p>⑭ IC301 - 71 pin (FPGA_DONE) V: 2V/div. H: 500mS/div.</p>	<p>A 3/4 MAIN ASSY Mode: PLAY</p> <p>㉓ IC407 - 5 pin (16MHz CLOCK) V: 1V/div. H: 20nS/div.</p>

Note : The encircled numbers denote measuring point in the schematic diagram and pcb diagram.

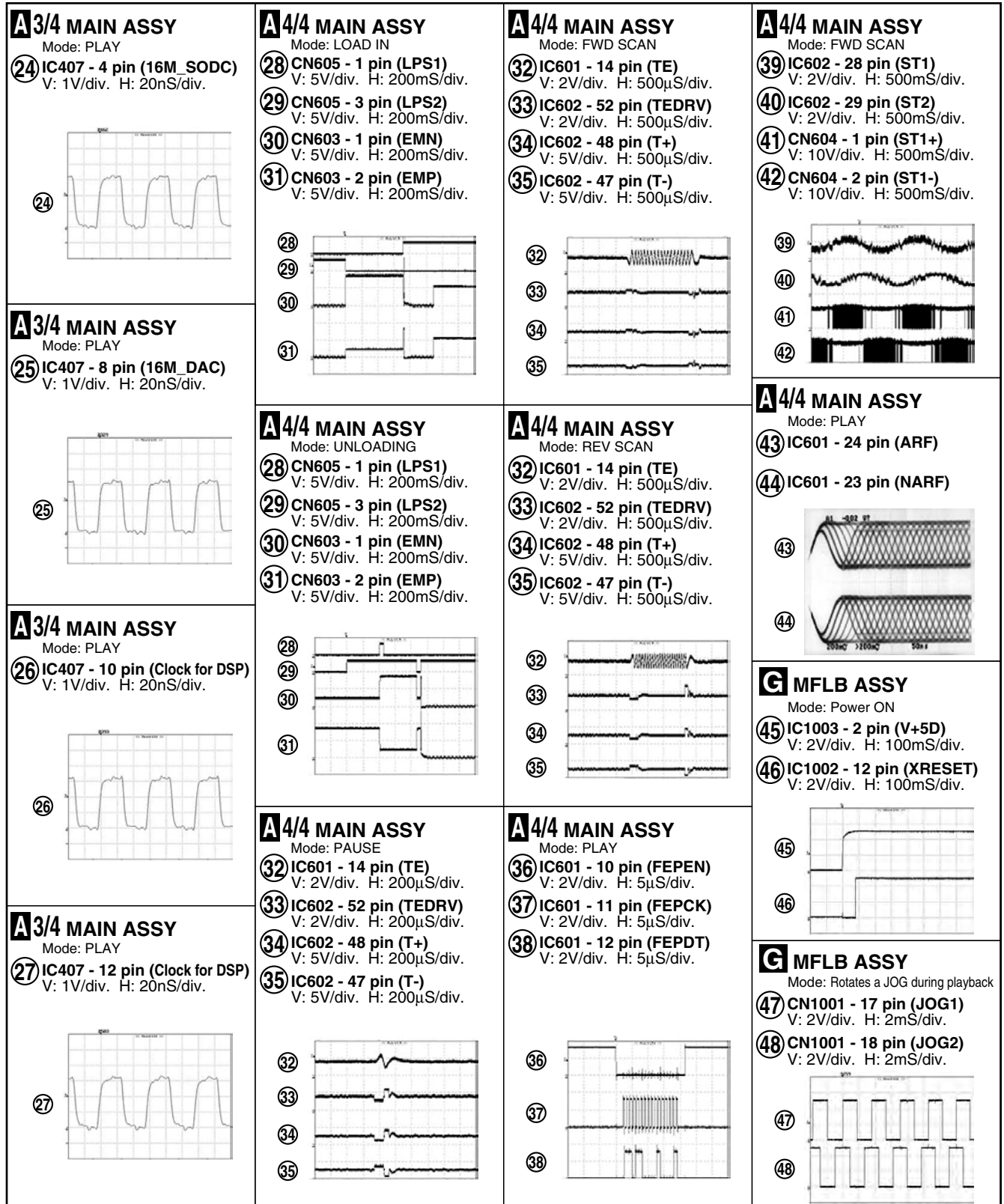

SIDE A

A MAIN ASSY

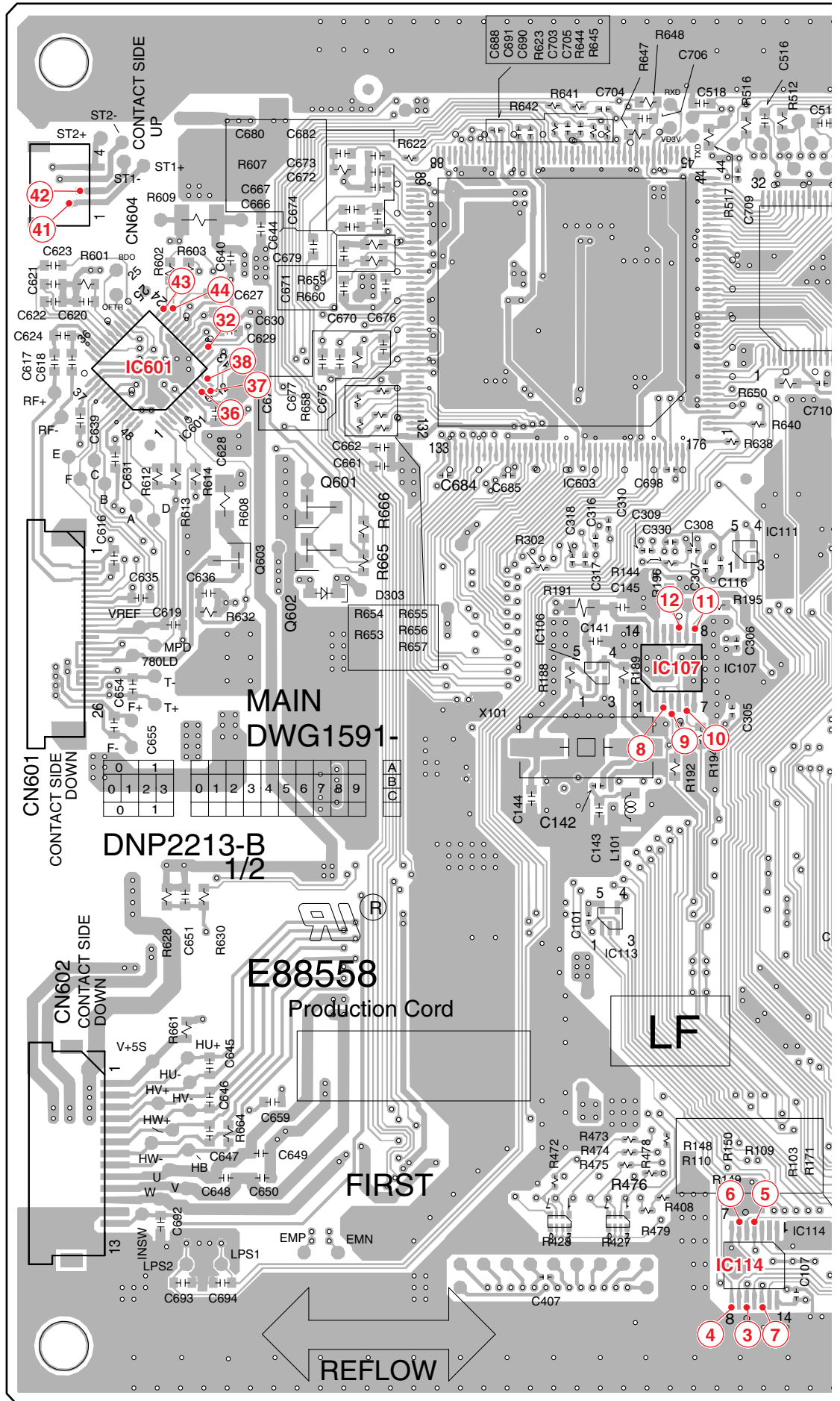

A
B
C
D
E
F

A

SIDE A

A
B
C
D
E
F

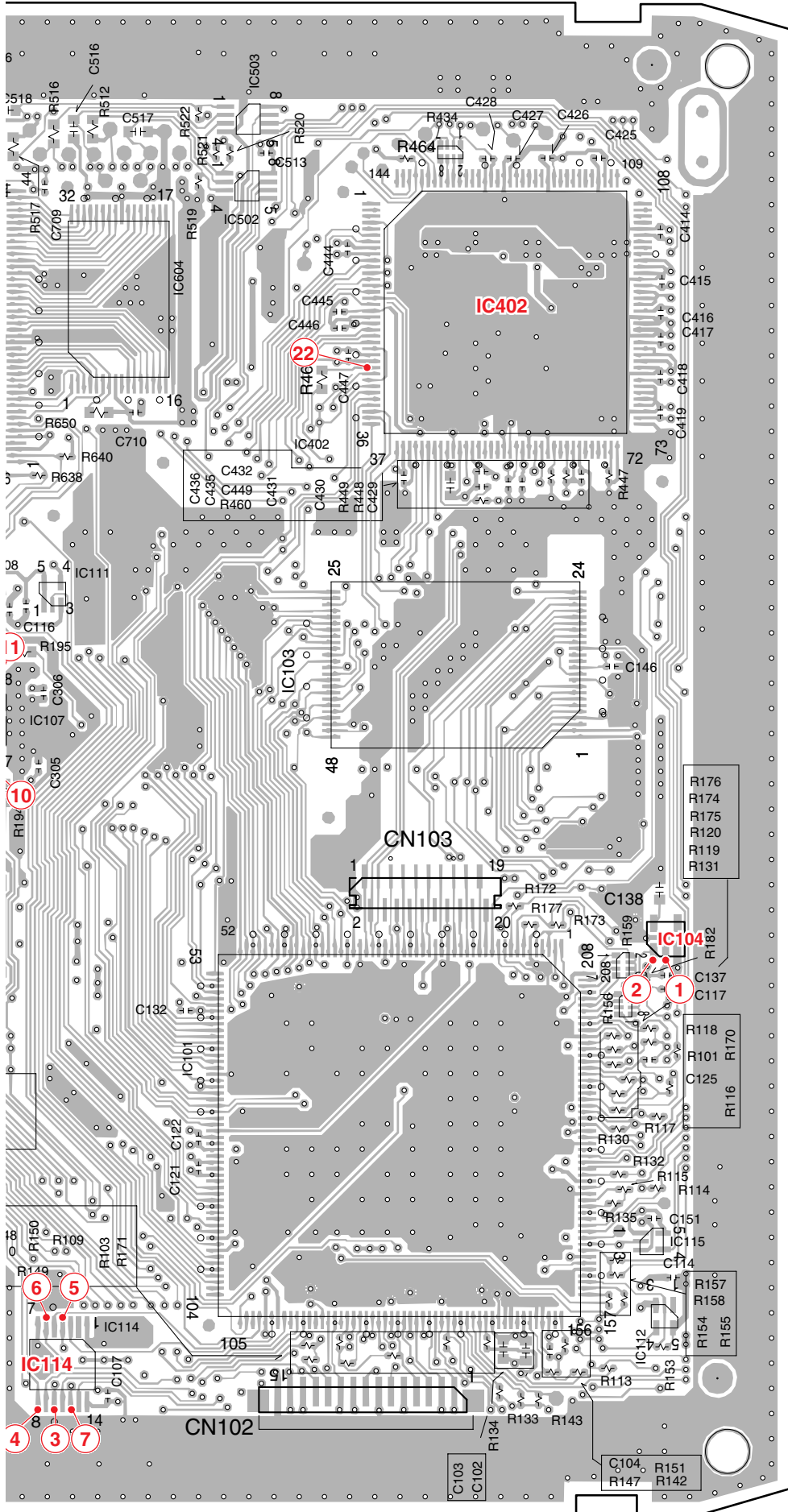

Note :
The encircled numbers denote measuring point.



SIDE B

A
MAIN ASSY

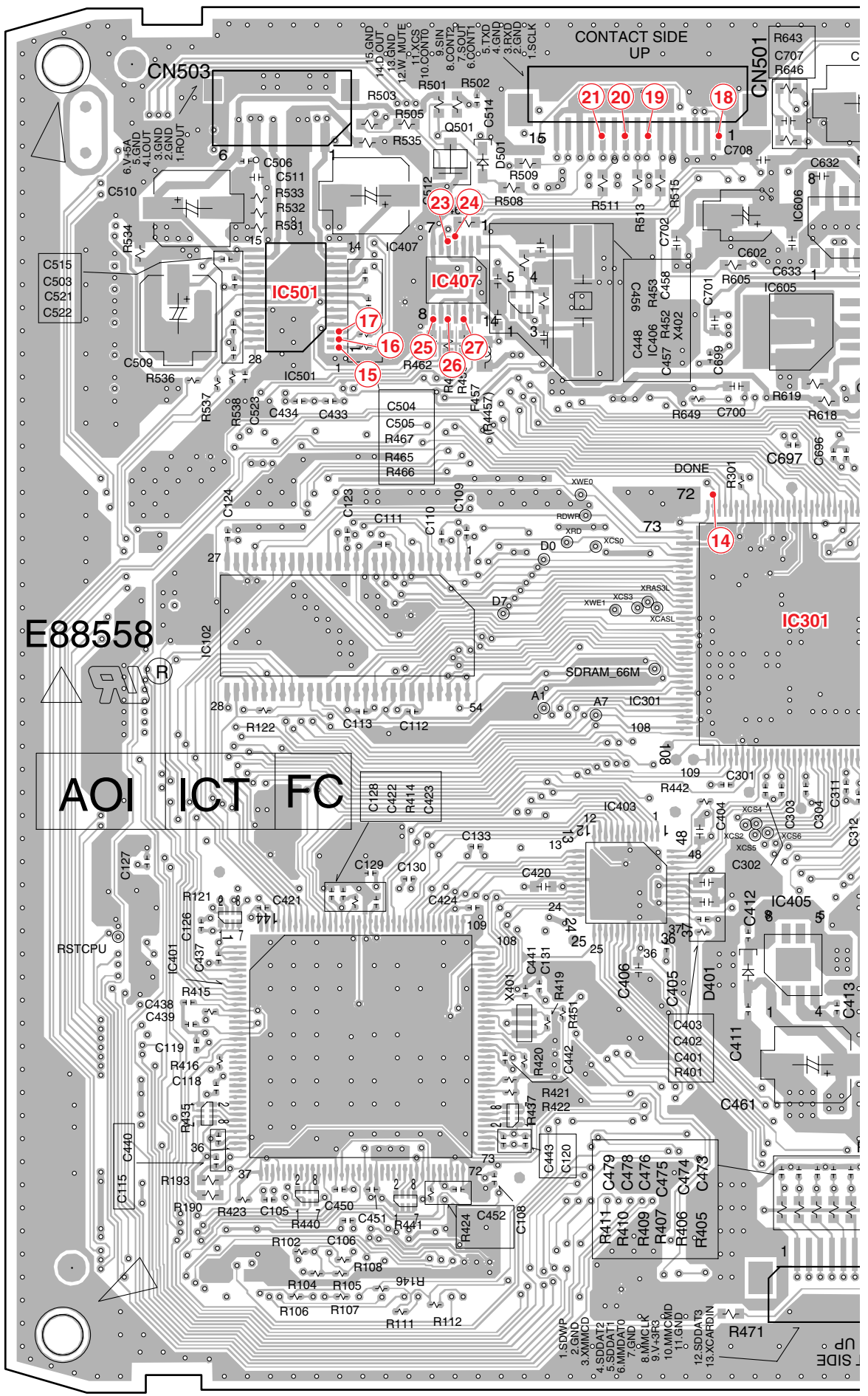

A
B
C
D
E
F

A

SIDE B

A
B
C
D
E
F

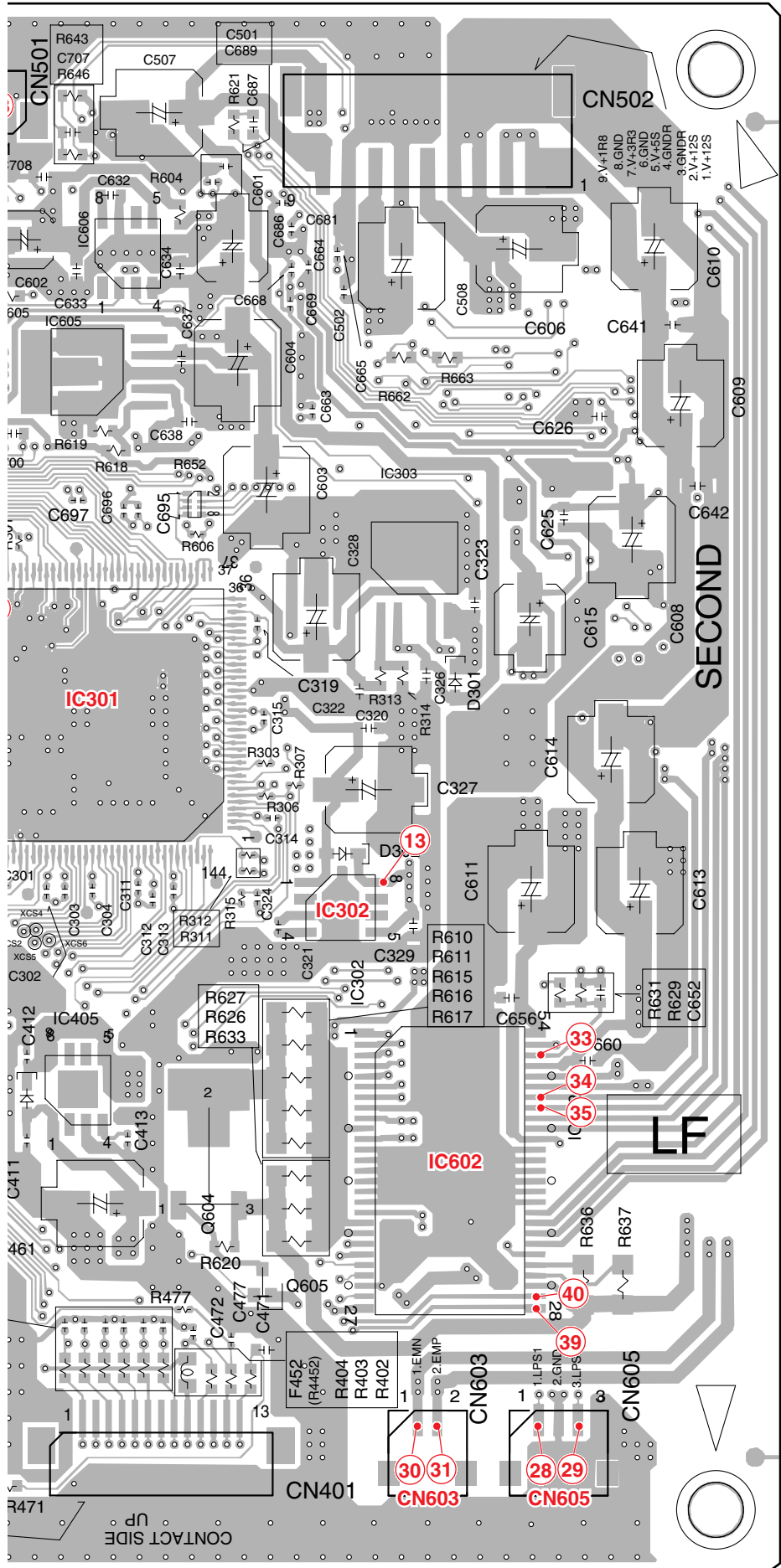

Note :
The encircled numbers denote measuring point.

(DNP2213-B)

A

SIDE B

A

B

C

D

E

F

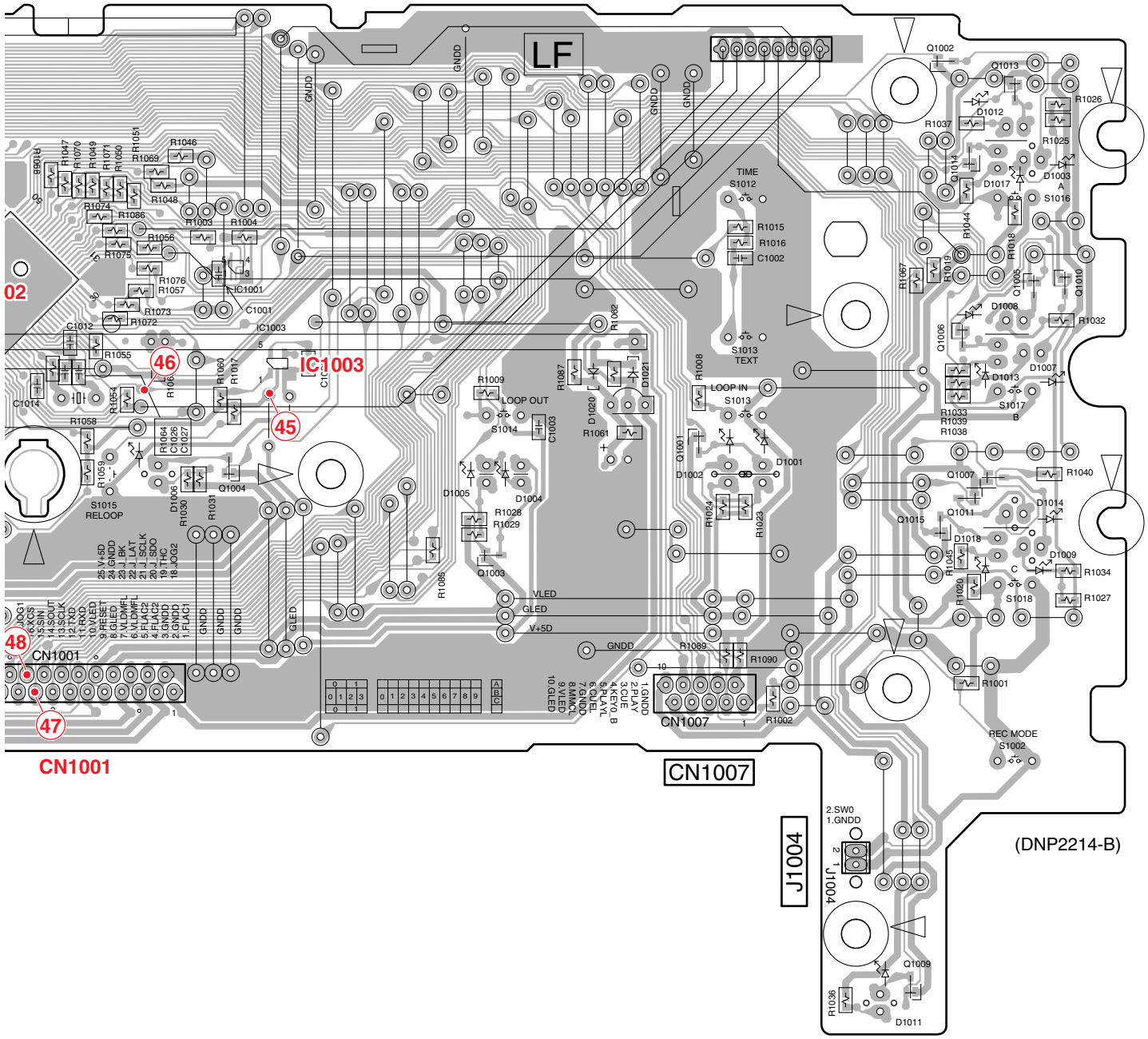

Note : The encircled numbers denote measuring point in the schematic diagram and pcb diagram.

A

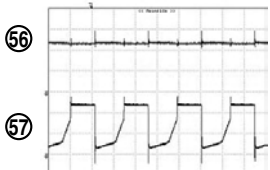
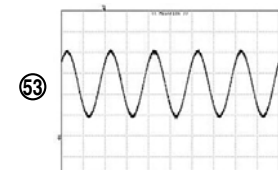
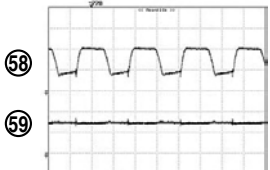
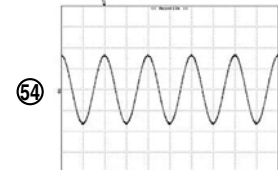
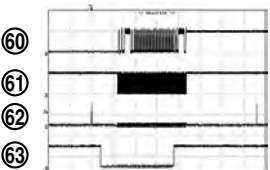
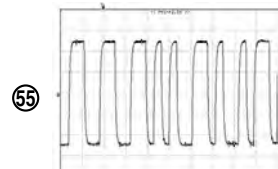
<p>G MFLB ASSY Mode: PLAY</p> <p>④9 V1001 - 71 pin (SI) V: 5V/div. H: 50μS/div.</p> <p>⑤0 V1001 - 72 pin (CLK) V: 5V/div. H: 50μS/div.</p> <p>⑤1 V1001 - 73 pin (LAT) V: 10V/div. H: 50μS/div.</p> <p>⑤2 V1001 - 74 pin (BK) V: 10V/div. H: 50μS/div.</p> 	<p>F MJCB ASSY Mode: PLAY</p> <p>⑤6 CN1504 - 18 pin (FLAC1) V: 5V/div. H: 5μS/div.</p> <p>⑤7 CN1504 - 16 pin (FLAC2) V: 5V/div. H: 5μS/div.</p> 
<p>F MJCB ASSY Mode: PLAY (1kHz, 0dB)</p> <p>⑤3 CN1506 - 1 pin (ROUT) V: 1V/div. H: 500μS/div.</p> 	<p>F MJCB ASSY Mode: PLAY</p> <p>⑤8 CN1504 - 14 pin (FLAC3) V: 5V/div. H: 5μS/div.</p> <p>⑤9 CN1504 - 12 pin (FLAC4) V: 5V/div. H: 5μS/div.</p> 
<p>F MJCB ASSY Mode: PLAY (1kHz, 0dB)</p> <p>⑤4 JA1502 - 1 pin (ROUT) V: 2V/div. H: 500μS/div.</p> 	<p>J JFLB ASSY Mode: PLAY</p> <p>⑥0 V2001 - 24 pin (SI) V: 5V/div. H: 100μS/div.</p> <p>⑥1 V2001 - 27 pin (CLK) V: 5V/div. H: 100μS/div.</p> <p>⑥2 V2001 - 26 pin (LAT) V: 5V/div. H: 100μS/div.</p> <p>⑥3 V2001 - 25 pin (BK) V: 5V/div. H: 100μS/div.</p> 
<p>F MJCB ASSY Mode: PLAY Measurement condition: Termination nothing. In case of 75 Ω termination, level becomes half (0.5V).</p> <p>⑤5 JA1503 (DOUT) V: 0.2V/div. H: 500nS/div.</p> 	

F

3.14 VOLTAGES

VOLTAGES

Voltage measurement condition: CD playback, CDJ, MASTER TEMPO: OFF, SLIDER: 0%

A 1/4 MAIN ASSY

• Remove CN401

IC101 (HD6417709SF133B-D)

Pin	Voltage (V)	Pin	Voltage (V)	Pin	Voltage (V)
1	3.31	72	0.085 to 0.095	143	0.011
2	3.30	73	0.34 to 0.37	144	3.31
3	1.754	74	0.52 to 0.85	145	1.751
4	0.010	75	0.43 to 0.56	146	0.816
5	1.754	76	0.9 to 1.4	147	0.009
6	0.009	77	0.17 to 0.41	148	0.008
7	0.008	78	0.42 to 0.61	149	0.008
8	3.31	79	0.008	150	1.751
9	3.31	80	0.015 to 0.018	151	0.011 to 0.035
10	3.31	81	1.749	152	0.009
11	3.31	82	0.02 to 0.08	153	0.009
12	2.370	83	0.008	154	1.751
13	3.31	84	0.13 to 0.16	155	0.009
14	3.31	85	3.31	156	0.009
15	3.31	86	0.008	157	0.009
16	3.31	87	2.63 to 2.66	158	0.008
17	3.31	88	3.31	159	0.015
18	3.31	89	1.7 to 2.2	160	3.26
19	0.008	90	2.20 to 2.30	161	0.009
20	3.31	91	3.31	162	1.675
21	3.31	92	0.055 to 0.110	163	3.31
22	3.31	93	3.22 to 3.25	164	0.010
23	3.31	94	3.31	165	3.31
24	3.31	95	0.008	166	0.15 to 0.26
25	3.31	96	3.31	167	0.009
26	3.31	97	3.31	168	3.31
27	0.008	98	3.0 to 3.3	169	0.008
28	3.31	99	1.9 to 2.1	170	0.008
29	1.752	100	3.31	171	3.31
30	0.011	101	0.033 to 0.080	172	3.31
31	0.011	102	3.31	173	0.008
32	0.011	103	3.30	174	3.31
33	0.008	104	3.30	175	1.751
34	0.63 to 0.84	105	3.31	176	3.31
35	3.31	106	0.11 to 0.15	177	3.31
36	1.57 to 1.65	107	3.31	178	0.009
37	1.53	108	2.657	179	3.27
38	0.64 to 1.2	109	0.009	180	3.30
39	0.5 to 1.2	110	0.009	181	0.008
40	1.27 to 1.31	111	3.31	182	0.008
41	1.3 to 1.4	112	0.010	183	3.31
42	1.39 to 1.41	113	3.31	184	0.008
43	1.39 to 1.43	114	0.010	185	3.31
44	1.40 to 1.54	115	3.28	186	3.31
45	0.008	116	3.31	187	0.011 to 0.017
46	1.50 to 1.52	117	3.31	188	3.31
47	3.31	118	3.31	189	3.31
48	0.95 to 1.10	119	3.31	190	0.008
49	1.1 to 1.3	120	3.31	191	3.31
50	1.43	121	3.31	192	0.015 to 0.055
51	1.47 to 1.53	122	3.31	193	3.31
52	1.38 to 1.40	123	3.30	194	3.31
53	0.53 to 0.75	124	3.31	195	0.008
54	1.80 to 1.85	125	2.540	196	3.31
55	1.69 to 1.74	126	3.31	197	0.008
56	1.67 to 1.73	127	3.31	198	0.009
57	0.008	128	3.31	199	3.31
58	1.42 to 1.63	129	3.31	200	0.009
59	3.31	130	0.008 to 0.030	201	0.035 to 0.150
60	1.38 to 1.53	131	0.016	202	3.31
61	1.33 to 1.42	132	0.009	203	3.31
62	0.90 to 0.96	133	3.31	204	3.31
63	0.85 to 0.91	134	1.751	205	3.31
64	0.85 to 1.16	135	3.31	206	3.31
65	1.0 to 1.4	136	3.31	207	3.31
66	0.55 to 0.74	137	3.31	208	0.008
67	0.82 to 0.93	138	3.31		
68	0.10 to 0.45	139	3.31		
69	0.008	140	3.31		
70	0.22 to 0.86	141	3.31		
71	3.31	142	3.31		

IC102

(K4S281632F-UC75)

Pin	Voltage (V)
1	3.31
2	1.45 to 1.49
3	3.31
4	1.30 to 1.35
5	1.46 to 1.49
6	0.008
7	1.19 to 1.22
8	1.0 to 1.2
9	3.31
10	1.2 to 1.6
11	1.48 to 1.52
12	0.008
13	0.5 to 0.9
14	3.31
15	2.19 to 2.24
16	3.19 to 3.24
17	2.65 to 2.68
18	3.09 to 3.12
19	2.01 to 2.03
20	0.1 to 0.4
21	0.1 to 0.4
22	0.55 to 0.71
23	1.80 to 1.82
24	1.69 to 1.73
25	1.71 to 1.73
26	1.52 to 1.63
27	3.31
28	0.008
29	1.43 to 1.53
30	1.39 to 1.50
31	0.90 to 0.94
32	0.85 to 0.92
33	0.84 to 0.95
34	0.9 to 1.2
35	0.80 to 0.87
36	0.085 to 0.093
37	3.31
38	1.642
39	2.20 to 2.23
40	0.14 to 0.20
41	0.009
42	1.42 to 1.45
43	3.31
44	1.35 to 1.43
45	1.32 to 1.38
46	0.009
47	1.02 to 1.13
48	0.9 to 1.1
49	3.31
50	1.54 to 1.56
51	1.64 to 1.69
52	0.009
53	0.65 to 0.80
54	0.009

• Remove CN401

IC103 (DYW1752)

Pin	Voltage (V)
1	0.34 to 0.40
2	0.085 to 0.092
3	0.3 to 0.9
4	0.10 to 0.42
5	0.78 to 0.87
6	0.54 to 0.67
7	1.03 to 1.08
8	0.85 to 0.91
9	0.16 to 0.42
10	0.43 to 0.52
11	2.22
12	3.31
13	0.11 to 0.16
14	0.11 to 0.14
15	3.31
16	0.7 to 1.0
17	0.44 to 0.52
18	0.85 to 0.92
19	0.9 to 1.2
20	1.3 to 1.5
21	1.37 to 1.53
22	1.48 to 1.62
23	1.52 to 1.73
24	1.71 to 1.80
25	1.80 to 1.86
26	3.31
27	0.008
28	3.31
29	1.45 to 1.46
30	1.41 to 1.48
31	1.31 to 1.36
32	1.34 to 1.42
33	1.44 to 1.47
34	0.6 to 1.4
35	1.17 to 1.26
36	1.01 to 1.12
37	3.31
38	0.99 to 1.05
39	0.91 to 1.07
40	1.50 to 1.53
41	1.43 to 1.58
42	1.48 to 1.50
43	1.53 to 1.65
44	0.52 to 0.81
45	0.66 to 0.94
46	0.009
47	3.31
48	0.53 to 0.70

A 2/4 MAIN ASSY

IC301 (XC3S50-4TQG144C)

Pin	Voltage (V)	Pin	Voltage (V)
1	0.009	73	0.115
2	3.31	74	2.22 to 2.24
3	3.31	75	3.31
4	3.31	76	3.245
5	3.31	77	3.1 to 3.3
6	0.	78	1.44 to 1.47
7	3.31	79	1.28 to 1.37
8	3.31	80	1.43 to 1.46
9	0.009	81	0.008
10	3.31	82	1.16 to 1.29
11	3.31	83	0.97 to 1.20
12	1.74 to 1.79	84	1.53 to 1.55
13	1.87 to 1.91	85	1.47 to 1.51
14	1.66 to 1.77	86	0.5 to 0.8
15	3.31	87	2.21 to 2.30
16	0.009	88	0.008
17	3.31	89	1.39 to 1.41
18	0 to 0.6	90	1.32 to 1.39
19	3.31	91	3.31
20	0 to 0.6	92	1.27 to 1.32
21	0 to 0.5	93	1.00 to 1.09
22	0.009	94	0.008
23	0 to 0.6	95	0.9 to 1.0
24	0 to 0.6	96	1.52 to 1.53
25	0 to 0.6	97	1.59 to 1.61
26	0 to 0.6	98	0.63 to 0.82
27	0 to 0.6	99	1.80 to 1.85
28	0 to 0.5	100	1.69 to 1.76
29	0.009	101	0.008
30	0 to 3.31	102	1.58 to 1.73
31	0 to 0.6	103	1.47 to 1.63
32	0 to 0.6	104	1.37 to 1.53
33	0 to 0.6	105	1.35 to 1.50
34	3.31	106	3.31
35	0 to 3.31	107	0.90 to 0.94
36	0 to 0.6	108	0.85 to 0.93
37	2.520	109	2.517
38	2.520	110	2.517
39	2.520	111	2.517
40	0 to 0.6	112	0.55 to 0.72
41	1.2 to 1.6	113	0.95 to 1.10
42	0.009	114	0.009
43	3.31	115	3.31
44	2.368	116	0.84 to 0.87
45	0.009	117	0.008
46	2.5 to 2.9	118	0.009
47	3.166	119	3.31
48	2.520	120	2.522
49	1.211	121	1.211
50	0.009	122	3.31
51	0.044 to 0.046	123	3.31
52	0.044 to 0.046	124	2.63 to 2.67
53	0.044 to 0.046	125	0.006
54	3.31	126	3.31
55	0.044 to 0.046	127	3.1 to 3.3
56	1.651	128	3.31
57	0.010	129	3.31
58	3.31	130	3.31
59	1.663	131	0 to 0.2
60	1.907	132	3.28
61	1.211	133	1.210
62	2.521	134	2.520
63	3.202	135	3.30
64	0.009	136	0.008
65	0.010	137	2.3 to 3.3
66	3.31	138	3.31
67	0.009	139	0.009
68	3.31	140	0.346
69	3.31	141	3.31
70	3.31	142	0.009
71	2.540	143	2.521
72	2.522	144	2.518

IC501 (PE8001A)

Pin	Voltage (V)
1	1.661
2	0.77 to 0.85
3	1.650
4	2.254
5	1.634
6	2.814
7	0.009
8	5.00
9	5.00
10	0.001
11	2.504
12	0 to 0.08
13	2.517
14	0.009
15	5.00
16	2.514
17	0 to 0.03
18	2.503
19	0
20	5.00
21	4.99
22	5.00
23	0.010
24	4.98
25	4.98
26	0.011
27	3.31
28	3.31

A

A 3/4 MAIN ASSY

IC401 (TMS320DA150PGE16D)

Pin	Voltage (V)	Pin	Voltage (V)
1	0.008	73	1.43 to 1.51
2	0.008	74	1.47 to 1.50
3	0.008	75	3.31
4	3.31	76	0.009
5	0.55 to 0.65	77	0.009
6	0.009	78	0.009
7	0.82 to 1.10	79	3.31
8	3.30	80	2.807
9	0.007	81	3.31
10	0.007	82	0.011
11	0.008	83	3.31
12	1.626	84	3.31
13	3.31	85	1.23 to 1.25
14	0.008	86	3.30
15	0.008	87	0.012
16	1.626	88	3.30
17	3.31	89	3.30
18	3.20 to 3.25	90	0.009
19	3.31	91	1.625
20	3.31	92	2.802
21	3.31	93	0.009
22	3.31	94	3.31
23	3.31	95	0.011
24	3.31	96	0.713
25	3.31	97	1.042
26	3.31	98	3.31
27	3.31	99	1.44 to 1.46
28	3.31	100	1.28 to 1.33
29	3.31	101	1.42 to 1.46
30	3.31	102	1.17 to 1.29
31	3.31	103	0.98 to 1.14
32	0.008	104	1.52 to 1.54
33	3.31	105	0.53 to 0.57
34	0.008	106	0.009
35	3.31	107	0.38 to 0.48
36	1.25 to 1.30	108	0.009
37	0.008	109	0.009
38	1.24 to 1.27	110	0.008
39	0.008	111	0.008
40	0.008	112	3.31
41	1.32 to 1.38	113	1.46 to 1.49
42	1.22 to 1.30	114	0.5 to 0.8
43	1.23 to 1.25	115	1.40 to 1.45
44	1.23 to 1.25	116	1.33
45	3.31	117	1.28 to 1.35
46	0.008	118	0.99 to 1.15
47	3.31	119	0.92 to 1.09
48	0.015	120	0.010
49	1.28	121	1.50 to 1.54
50	0.008	122	1.62 to 1.68
51	0.009	123	0.65 to 0.81
52	1.626	124	0.010
53	3.31	125	1.626
54	1.26 to 1.28	126	0.009
55	3.31	127	3.31
56	3.31	128	0.009
57	0.008	129	3.31
58	3.31	130	3.31
59	0.009	131	1.80 to 1.86
60	0.009	132	1.69 to 1.75
61	3.31	133	1.34 to 1.73
62	0.008	134	1.45 to 1.63
63	0.008	135	0.010
64	0.009	136	1.42 to 1.53
65	0.009	137	1.3 to 1.5
66	0.009	138	0.90 to 0.94
67	0.008	139	0.85 to 0.87
68	1.626	140	0.85 to 0.93
69	3.30	141	0.95 to 1.12
70	0.008	142	1.628
71	1.25 to 1.27	143	0.009
72	0.008	144	0.009

B

C

D

E

F

• Remove CN401

IC402 (DSPD56367PV150)

Pin	Voltage (V)	Pin	Voltage (V)
1	2.23 to 2.26	73	0.008
2	1.17 to 1.22	74	3.31
3	1.00 to 1.04	75	0.008
4	0.008	76	0.008
5	0.008	77	0.008
6	0.045 to 0.046	78	0.008
7	0.045 to 0.046	79	0.008
8	3.31	80	3.31
9	0.009	81	0.009
10	0.045 to 0.046	82	0.009
11	0.044 to 0.046	83	0.009
12	1.661	84	0.009
13	1.664	85	0.009
14	1.65	86	3.31
15	1.927	87	0.009
16	1.625	88	0.009
17	3.204	89	0.009
18	1.753	90	0.009
19	0.009	91	1.757
20	3.31	92	0.008
21	3.31	93	0.008
22	3.31	94	0.008
23	0.012	95	3.31
24	0.009	96	0.008
25	3.31	97	0.008
26	0.009	98	0.008
27	1.681	99	0.008
28	0.009	100	0.013 to 0.015
29	0.009	101	0.013
30	3.31	102	0.020 to 0.100
31	1.68 to 1.75	103	3.31
32	1.81 to 1.84	104	0.008
33	0.75	105	0 to 0.07
34	0.39 to 0.78	106	0.019
35	1.47 to 1.48	107	0.015 to 0.017
36	1.52 to 1.53	108	0.015 to 0.017
37	0.6 to 1.4	109	0.012
38	3.31	110	0.013
39	0.008	111	3.31
40	1.19 to 1.30	112	0.008
41	1.47 to 1.49	113	0.013
42	1.38 to 1.45	114	0.012
43	1.47 to 1.49	115	0.012
44	3.31	116	0.012
45	1.759	117	0.012
46	0.383	118	0.012
47	0.008	119	3.31
48	0.115	120	0.008
49	3.31	121	0.012
50	0.009	122	0.012
51	0.60 to 0.72	123	0.012
52	1.1 to 1.2	124	0.012
53	0.009	125	0.012
54	0.008	126	1.756
55	1.629	127	0.008
56	1.756	128	0.012
57	3.31	129	3.31
58	0.008	130	0.008
59	1.663	131	0.013
60	1.896	132	0.019
61	0.008	133	0.013
62	0.008	134	3.30
63	3.31	135	3.30
64	3.30	136	0.010
65	3.31	137	0.009
66	0.008	138	0.009
67	0.46 to 0.52	139	0.30 to 0.32
68	0.61 to 0.68	140	0.010 to 0.060
69	0.48 to 0.52	141	3.25
70	0.43 to 0.52	142	3.29
71	0.008	143	0.34 to 0.39
72	0.008	144	1.54

G MFLB ASSY









IC1002 (PEG237A)

Pin	Voltage (V)	Pin	Voltage (V)
1	1.936	51	0.008
2	5.02	52	0.008
3	5.02	53	0.008
4	5.02	54	0.008
5	0.007	55	0.008
6	0.018	56	0.008
7	0.007	57	0.007
8	0.004	58	0.007
9	0.004	59	0.007
10	0.004	60	0.007
11	0.004	61	0.007
12	5.02	62	5.02
13	2.558	63	0.005
14	0.004	64	0.004
15	2.328	65	0.005
16	5.02	66	0.005
17	5.02	67	0.006
18	5.02	68	0.006
19	5.02	69	5.01
20	5.02	70	5.01
21	5.02	71	0.006
22	5.02	72	5.01
23	5.02	73	0.268
24	5.02	74	5.01
25	0.018	75	0.004
26	0 to 5.02	76	0.004
27	0.014 to 0.017	77	0.004
28	3.96	78	0.004
29	0.008	79	0.004
30	1.3 to 1.7	80	0.004
31	0.64 to 0.65	81	5.02
32	5.01	82	5.02
33	4.10	83	5.02
34	5.01	84	5.02
35	0.44 to 0.47	85	5.02
36	1.8 to 2.2	86	5.02
37	4.78	87	5.02
38	3.59	88	5.02
39	5.02	89	2.215
40	0.009	90	2.121
41	0.004	91	5.01
42	0.024	92	5.01
43	0.608	93	5.01
44	0.016	94	0.004
45	2.821	95	0.004
46	5.02	96	0.004
47	5.01	97	0.004
48	5.01	98	5.03
49	0.009	99	5.03
50	0.008	100	0.004

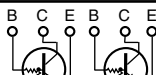
4. PCB CONNECTION DIAGRAM

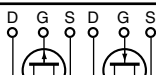
NOTE FOR PCB DIAGRAMS :

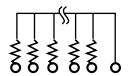
1. Part numbers in PCB diagrams match those in the schematic diagrams.
2. A comparison between the main parts of PCB and schematic diagrams is shown below.

Symbol In PCB Diagrams	Symbol In Schematic Diagrams	Part Name
		Transistor
		Transistor with resistor
		Field effect transistor
		Resistor array
		3-terminal regulator

3. The parts mounted on this PCB include all necessary parts for several destinations.
For further information for respective destinations, be sure to check with the schematic diagram.
4. View point of PCB diagrams.

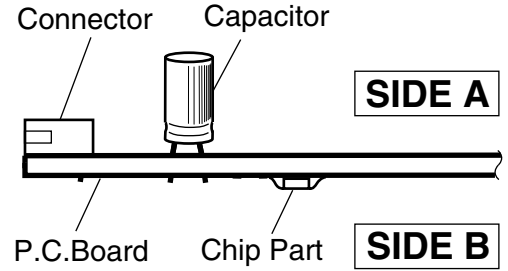

4.1 MAIN ASSY

SIDE A

MAIN ASSY

STEPPING MOTOR

PICKUP ASSY

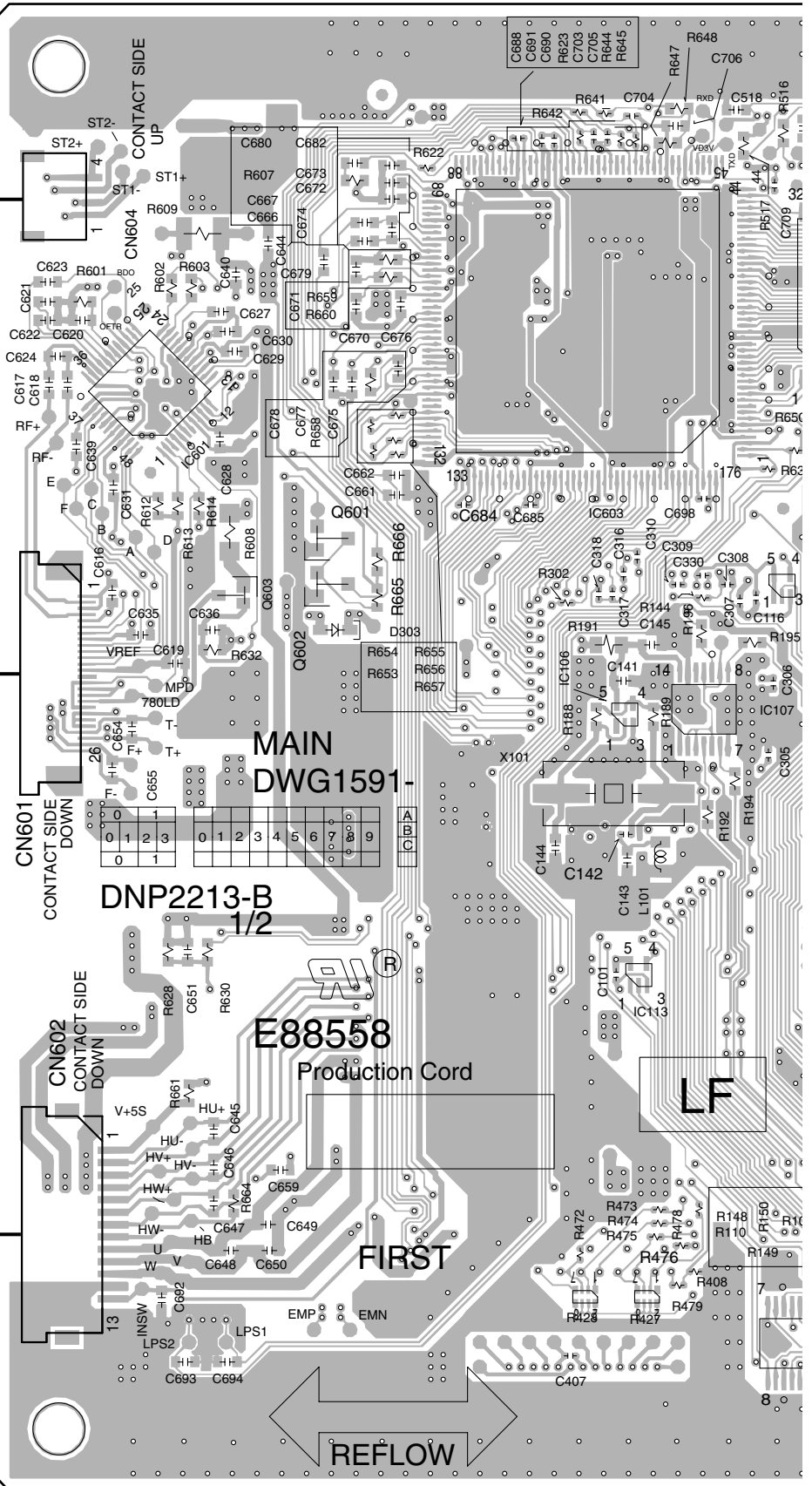

MAIN DWG1591-

DNP2213-B 1/2

E88558

Production Cord

LF

FIRST

REFLOW

CDJ-1000MK3

A

SIDE A

A
B
C
D
E
F

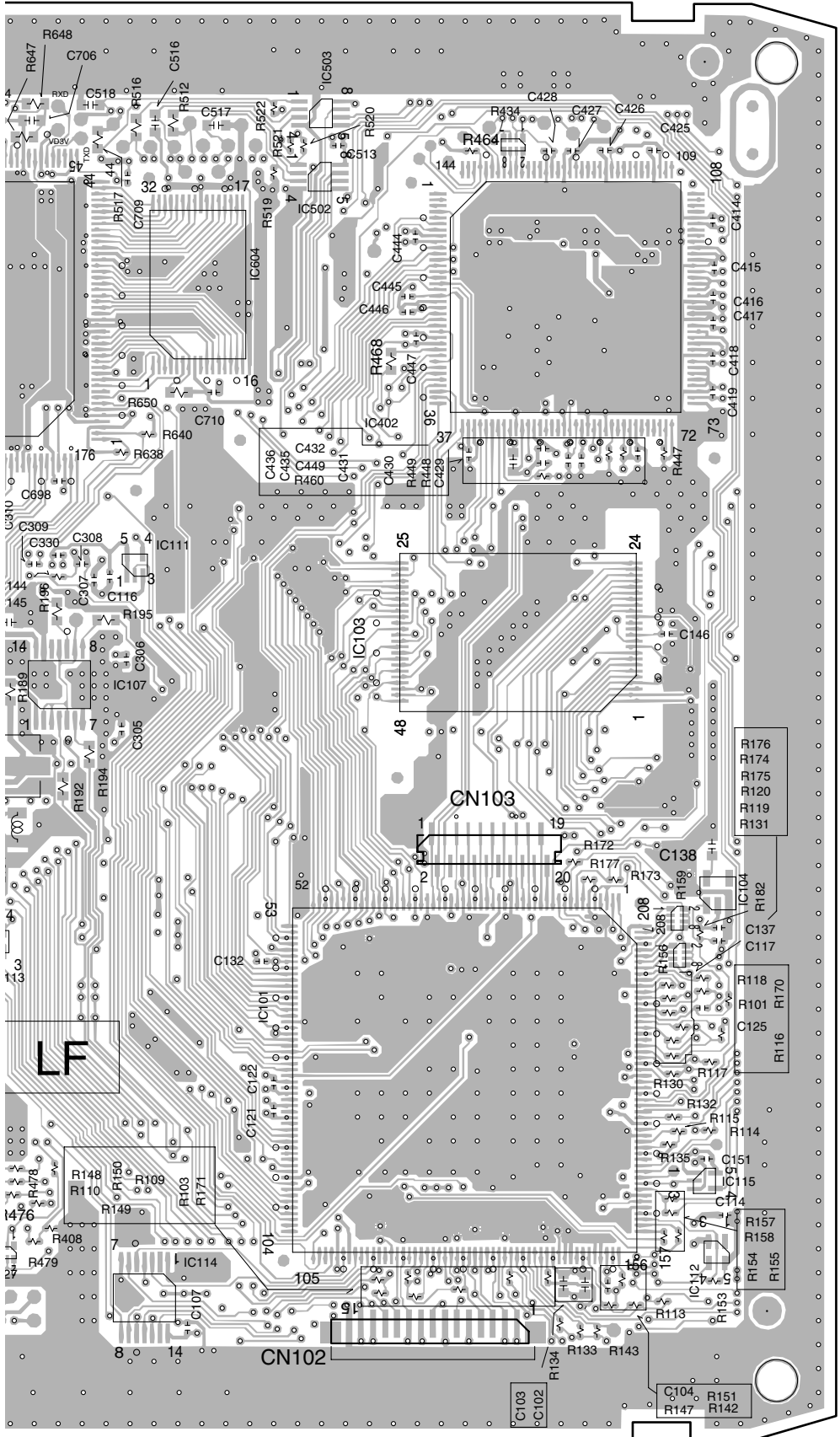

- IC503
- IC502
- IC603 IC604 IC402
- IC601
- Q601
- Q602 IC111
- Q603
- IC103
- IC106 IC107
- IC104
- IC113
- IC101
- IC115
- IC112
- IC114

(DNP2213-B)

SIDE B

A MAIN ASSY

F CN1506

F CN1502

CN503

CN501

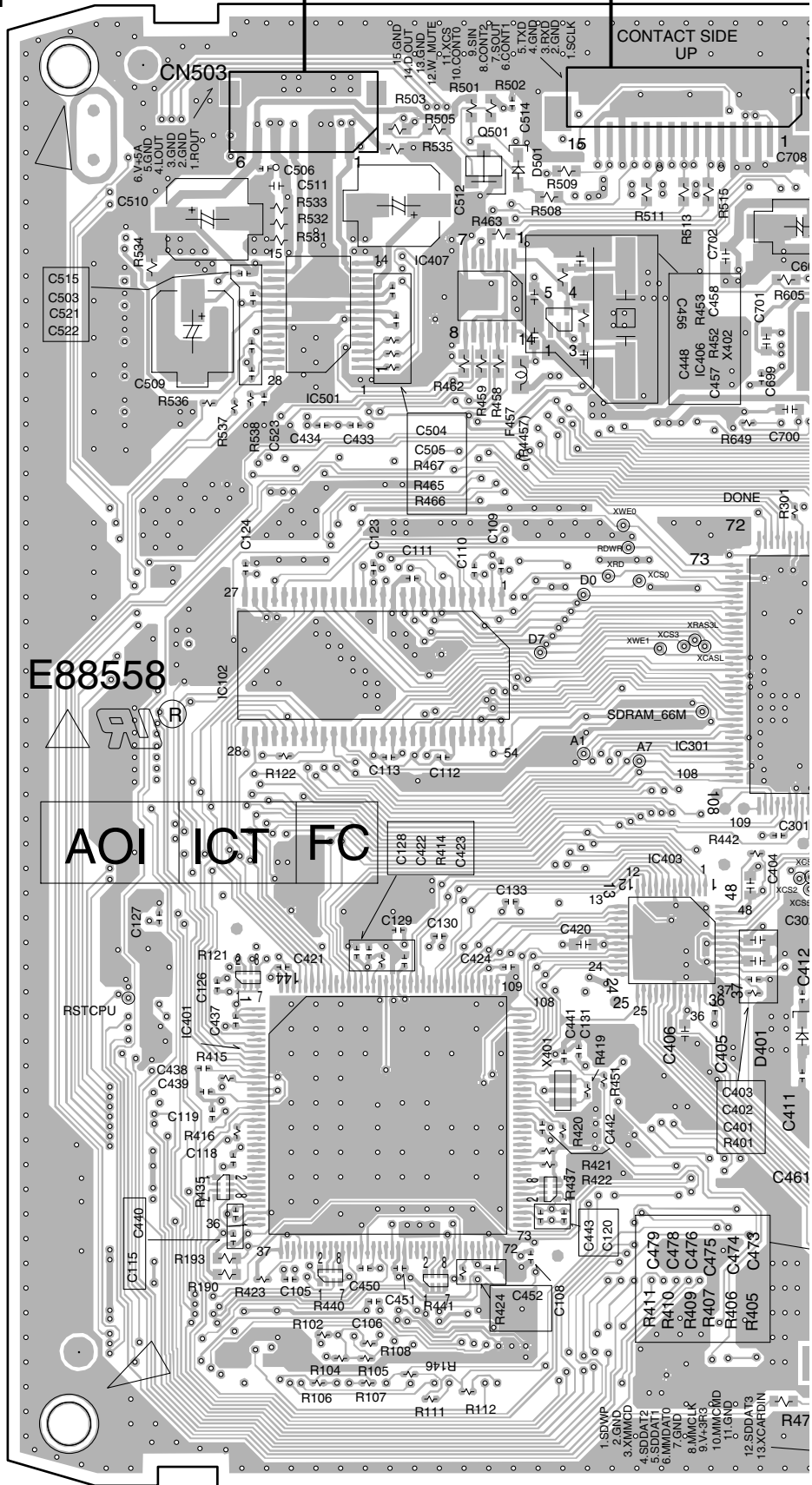

E88558

AOI ICT FC

SDRAM_66M

E CN3002

CDJ-1000MK3

A

B

C

D

E

F

SIDE B

SIDE B

A

B SLMB ASSY

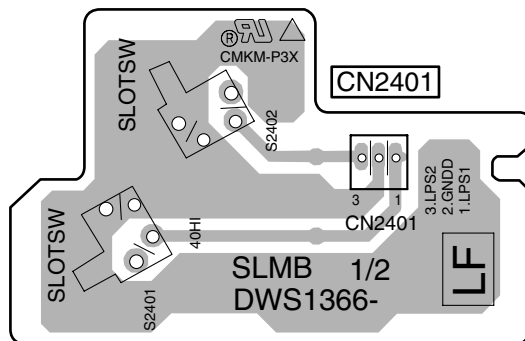

(DNP2212-B)

B

C

D

E

F

B

4.3 MJCB ASSY

SIDE A

F MJCB ASSY

A CN503 **M** CN601 **M**

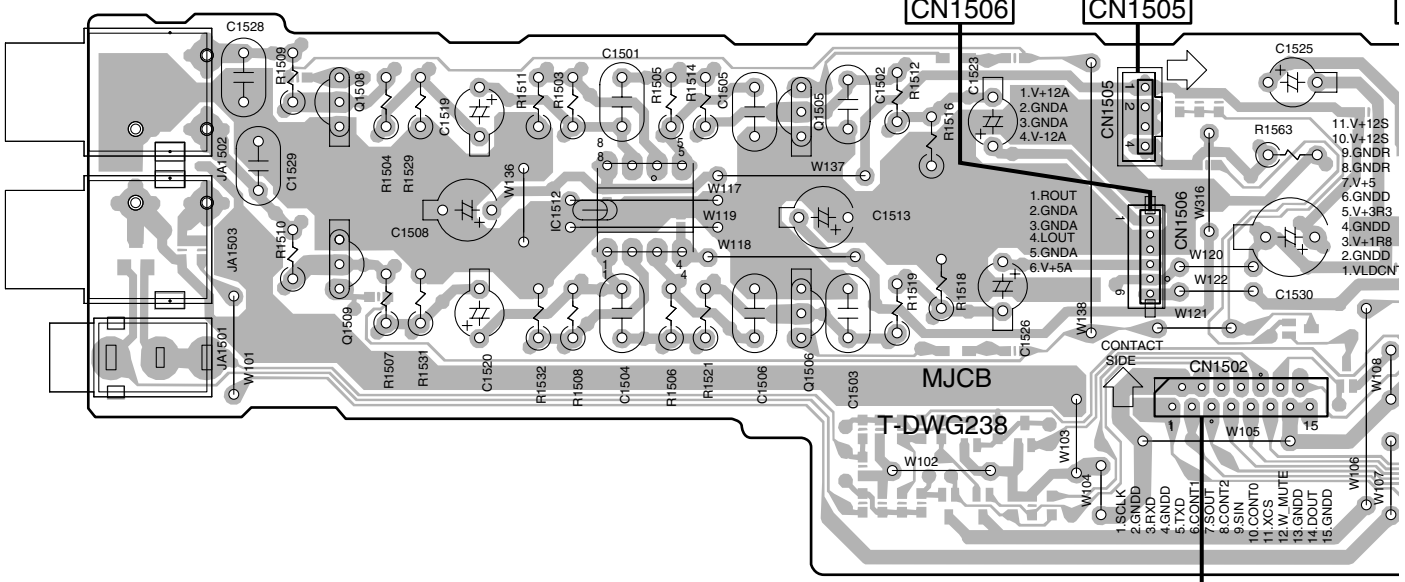

Q1508 IC1512 Q1505
Q1509 Q1506

A CN501

SIDE B

F MJCB ASSY

CN1502

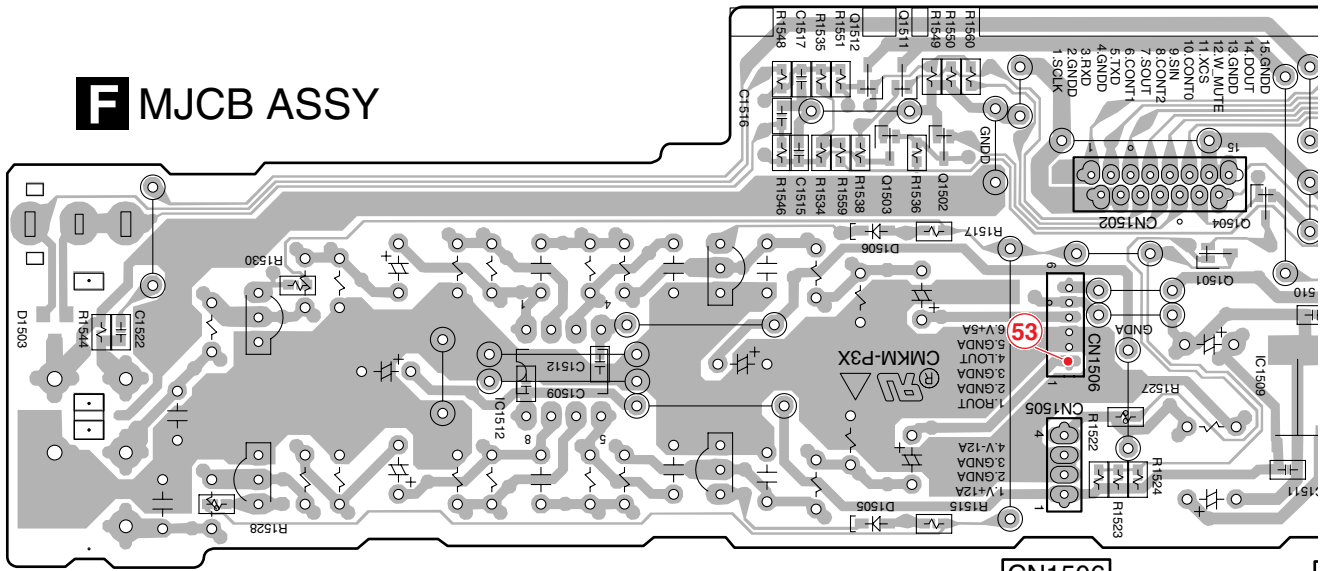

IC101 Q1512 Q1511 Q1504
Q1503 Q1502 Q1501 IC15C

F

SIDE A

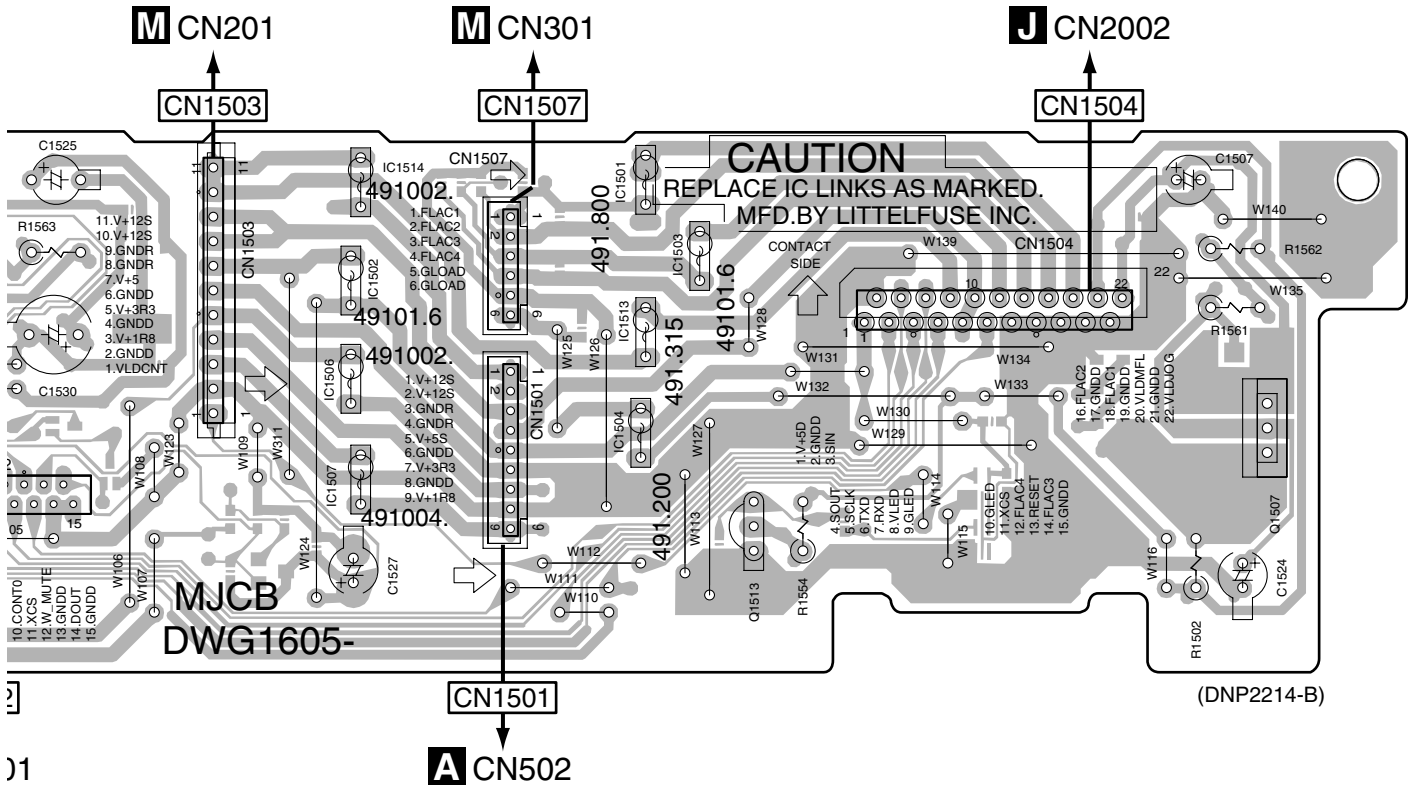

IC1502 IC1514
IC1506 IC1507

IC1501 IC1503
IC1513 Q1513
IC1504

Q1507

SIDE B

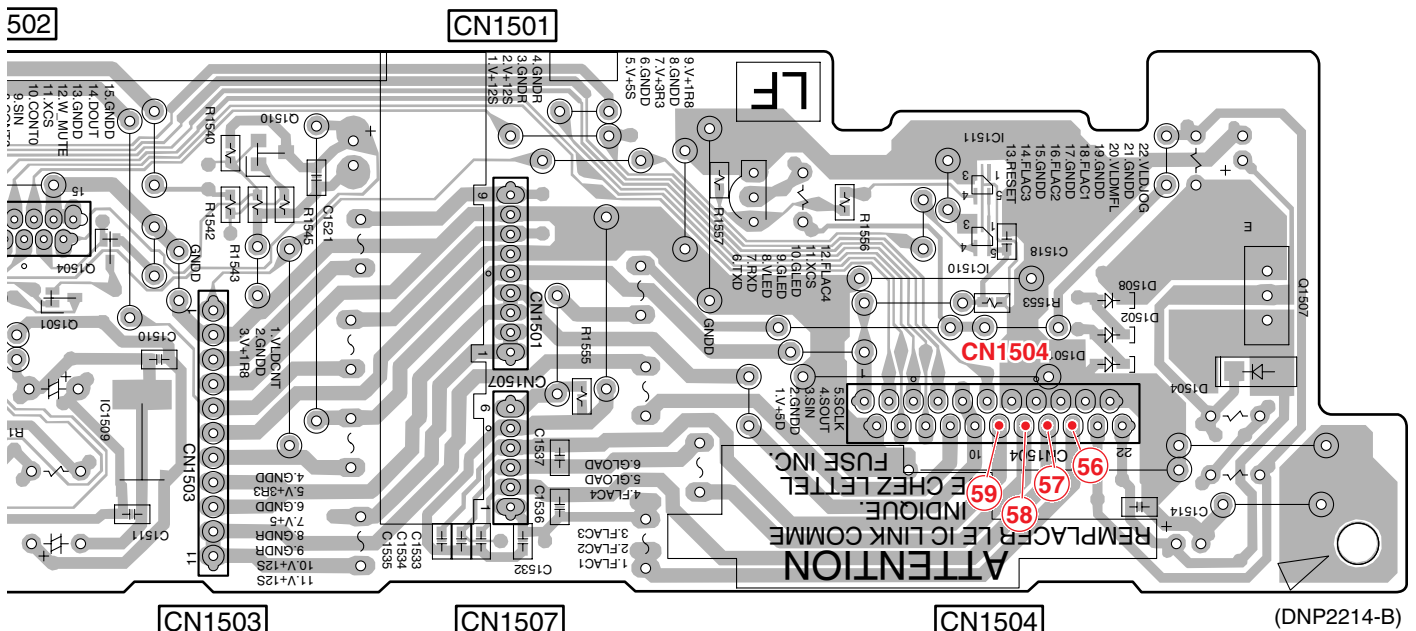

Note :
The encircled numbers denote measuring point.

Q1504
Q1501 IC1509

Q1510

IC1511
IC1510

Q1507



4.4 MFLB and RSWB ASSYS

SIDE A

G MFLB ASSY

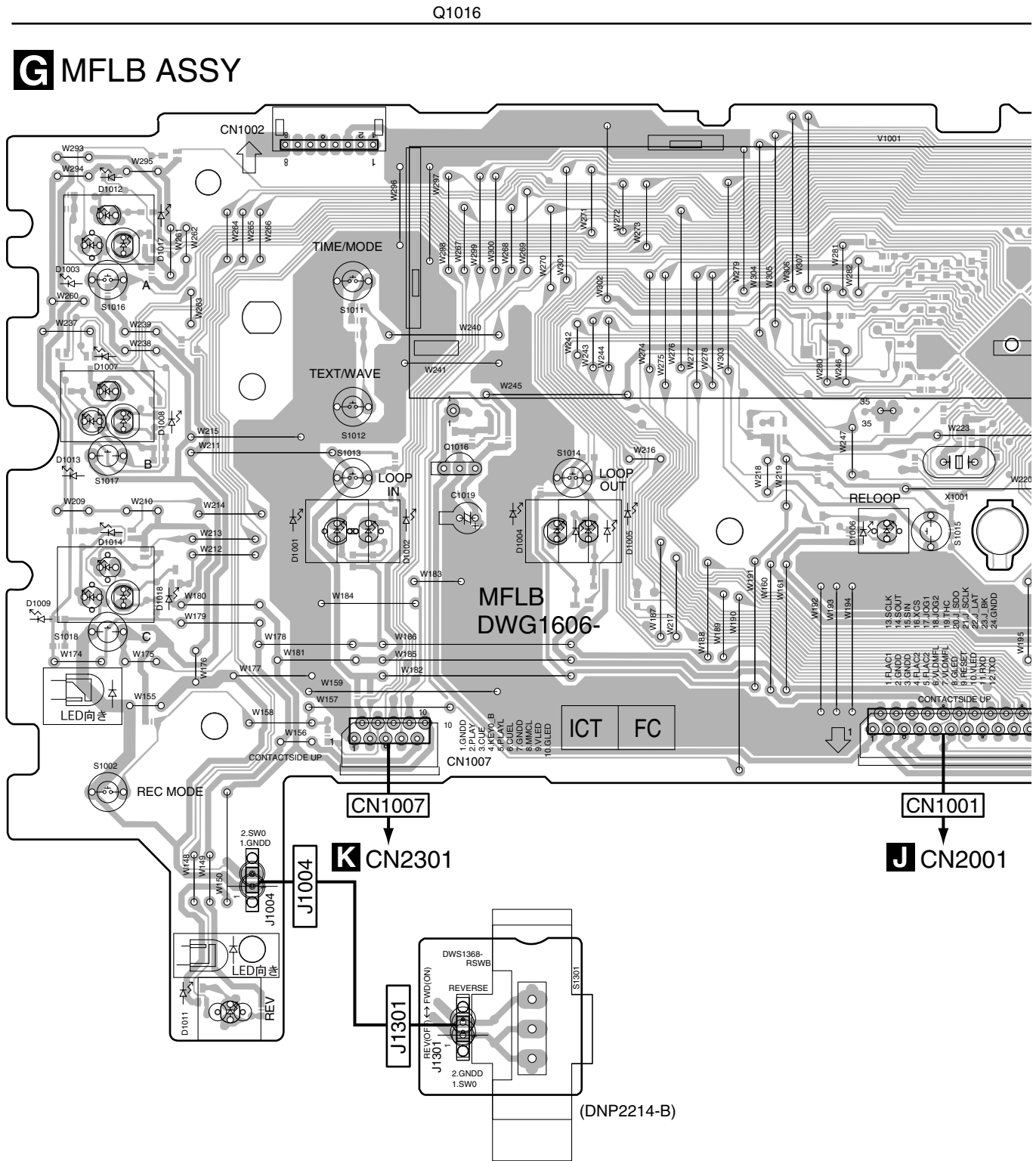

I RSWB ASSY

G I

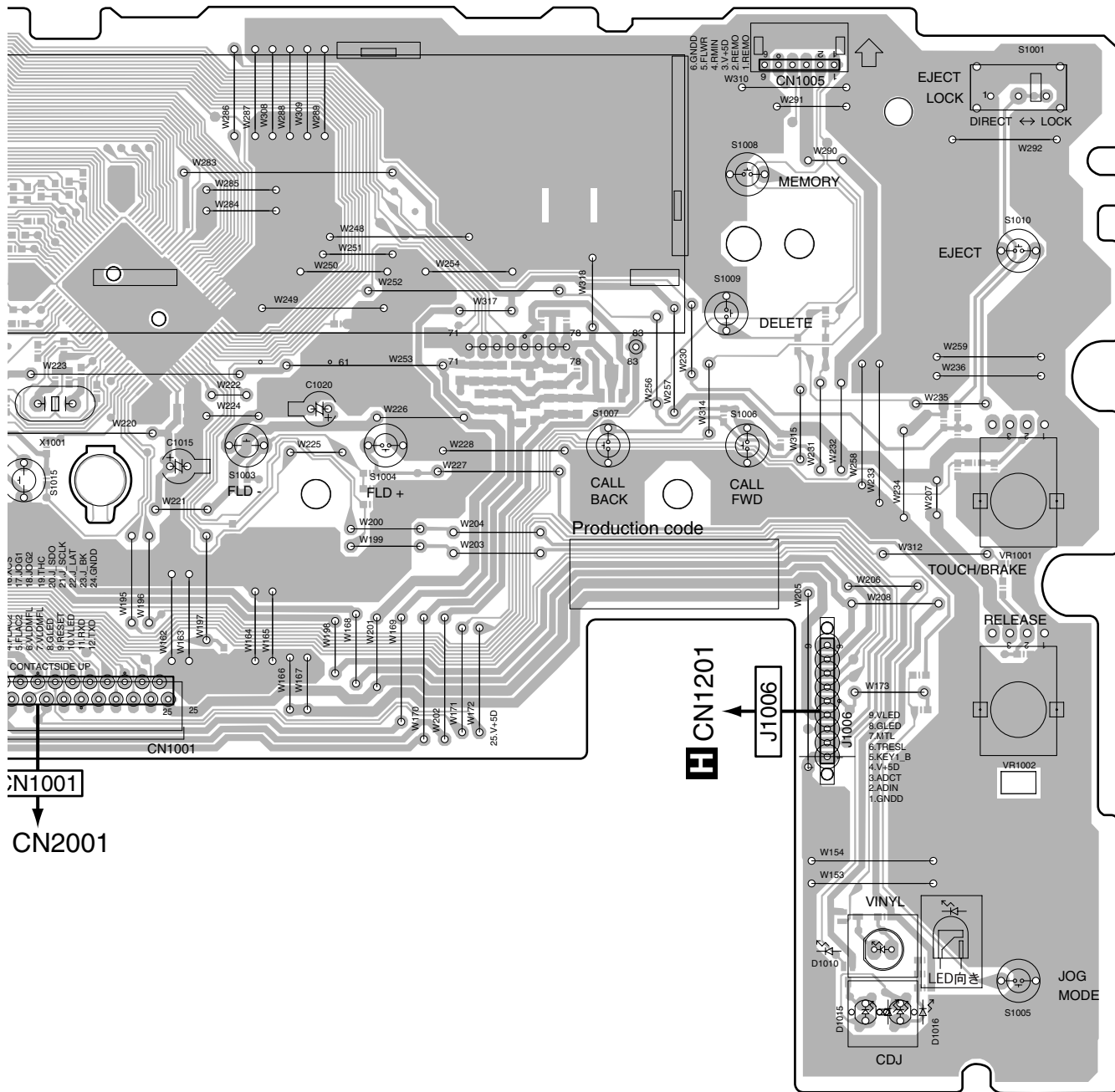

(DNP2214-B)

SIDE B

A

Q1008
Q1012

IC1004

IC1002

VR1001
VR1002

G MFLB ASSY

B

C

D

E

F

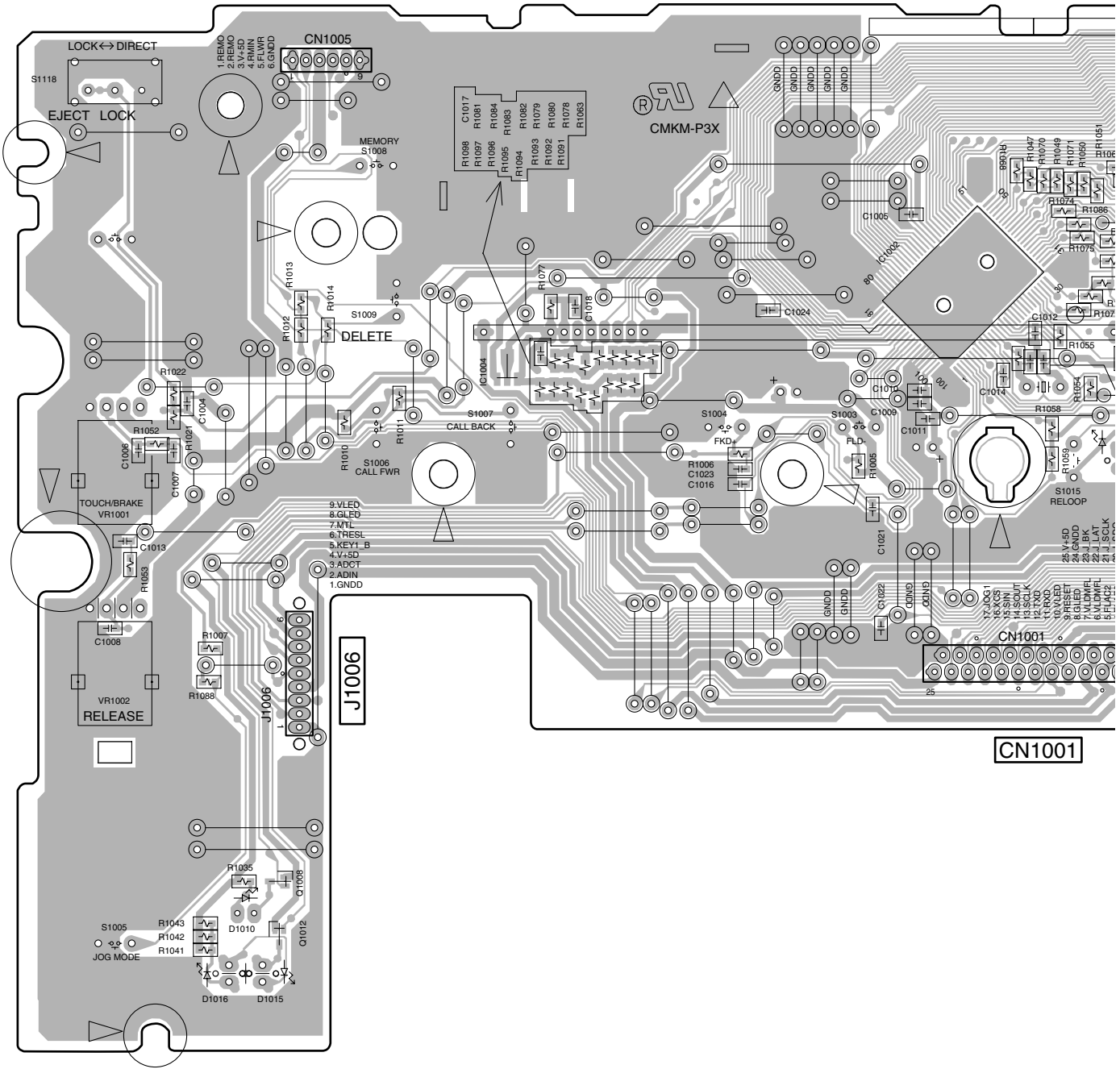

J1006

CN1001



SIDE B

IC1001 IC1003 Q1004 Q1003 Q1001 Q1002 Q1013 Q1014 Q1006 Q1005 Q1010 Q1007 Q1011 Q1015 Q1009

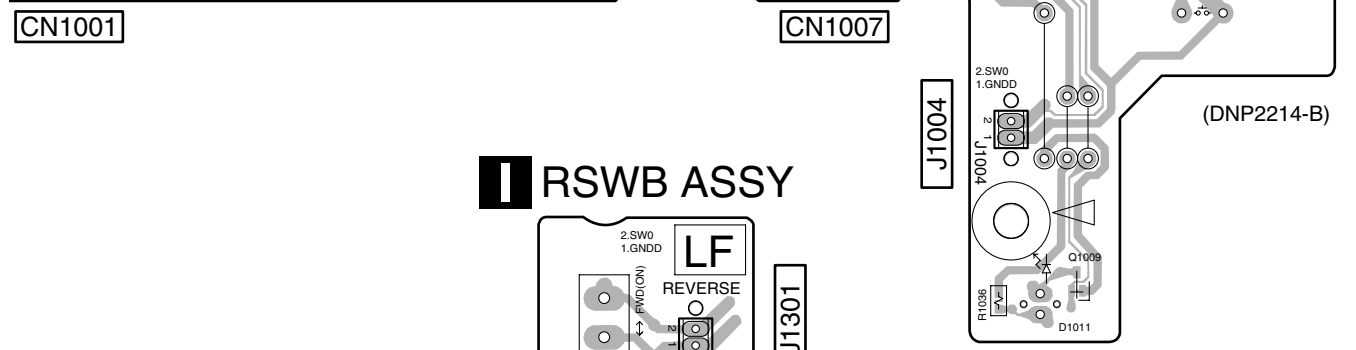
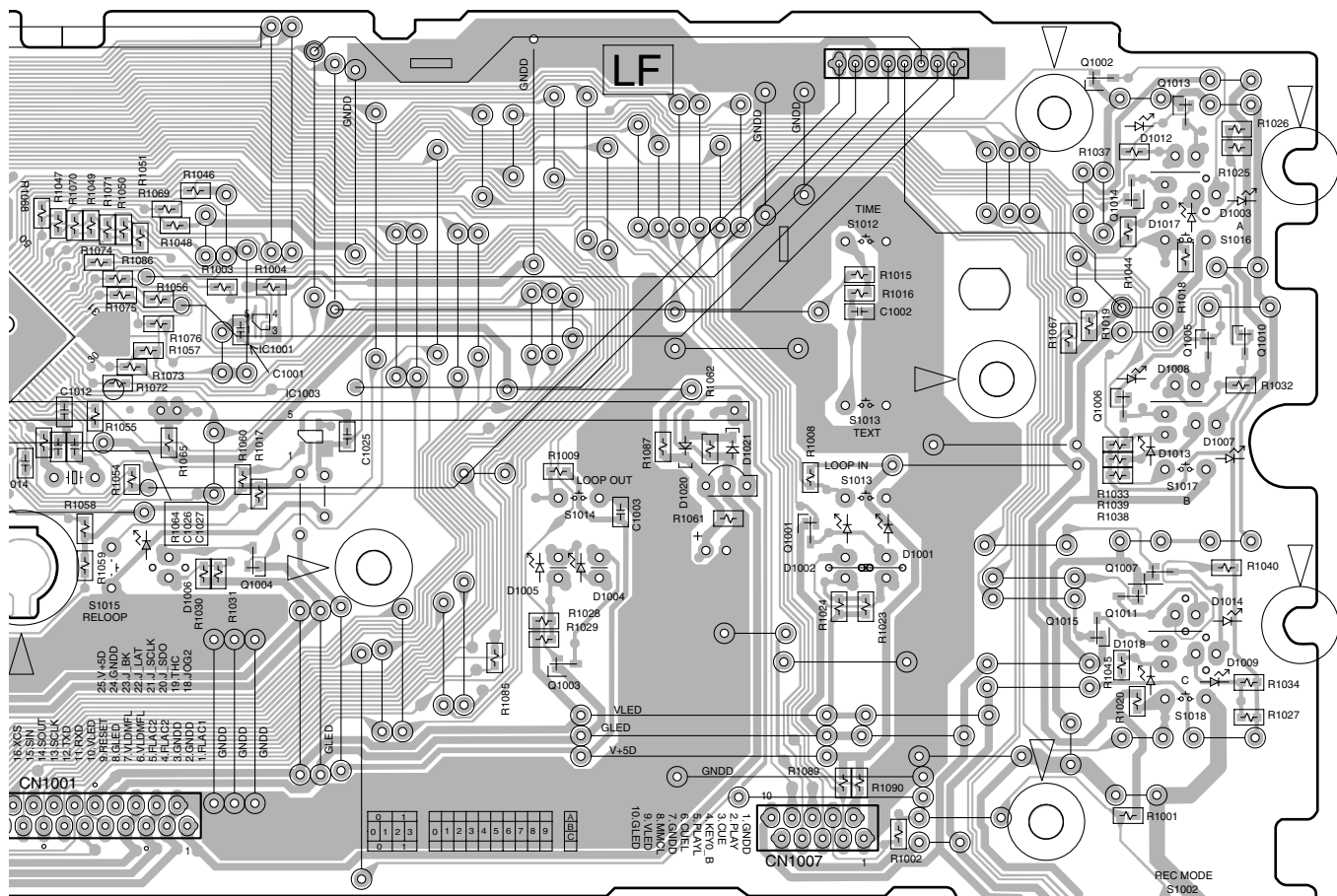

RSWB ASSY

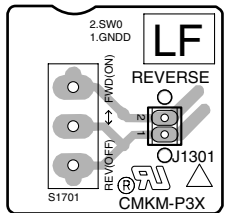

(DNP2214-B)

4.5 SLDB ASSY

SIDE A

SIDE B

H SLDB ASSY

H SLDB ASSY

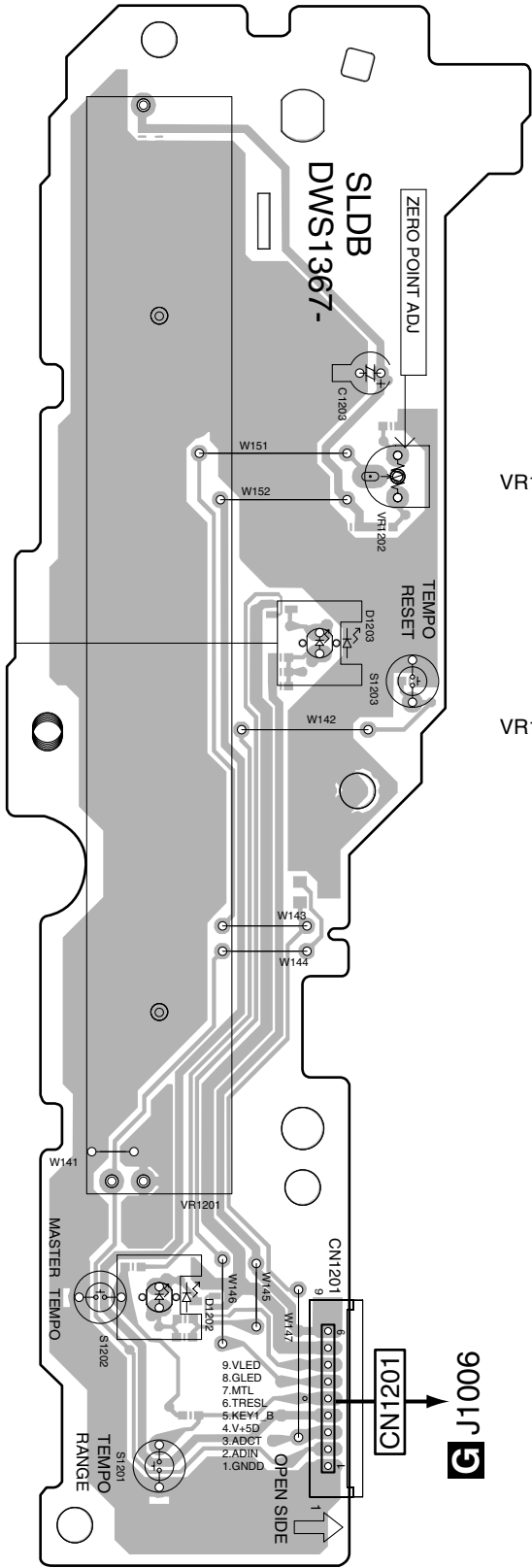

(DNP2214-B)

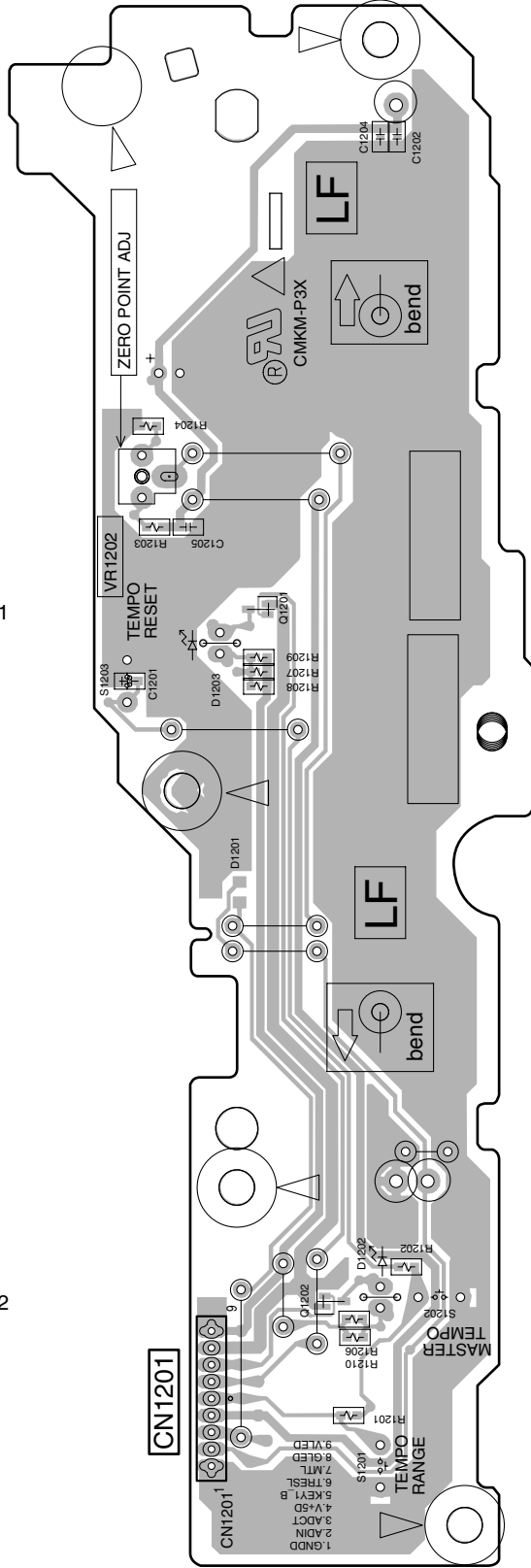

(DNP2214-B)



4.6 KSWB ASSY

SIDE A

SIDE B

K KSWB ASSY

K KSWB ASSY

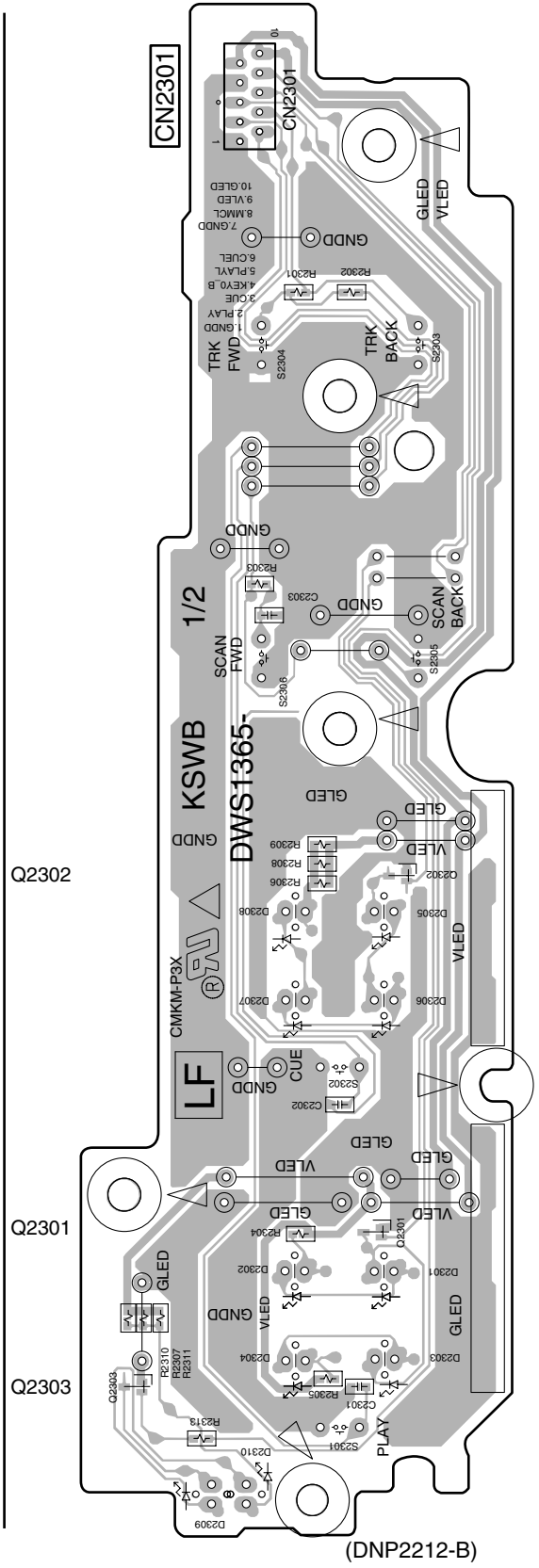
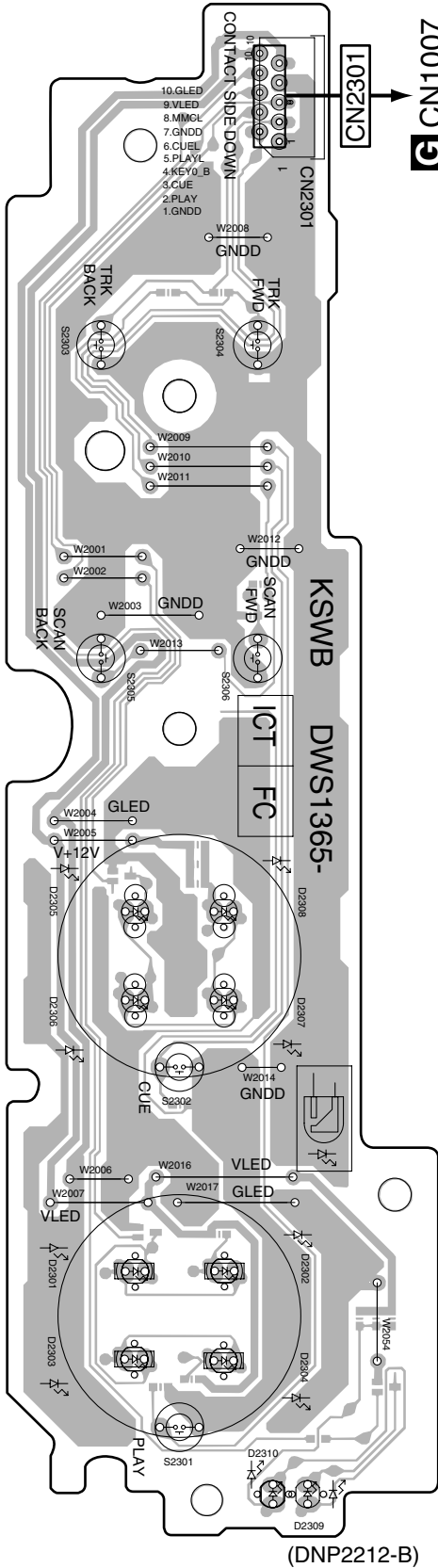

4.7 JFLB and JOGB ASSYS

SIDE A

SIDE A

Q2003
Q2002

Q2001

G CN1001

J JFLB ASSY

CN2001

JFLB DWG1602-

A
B
C
D
E
F

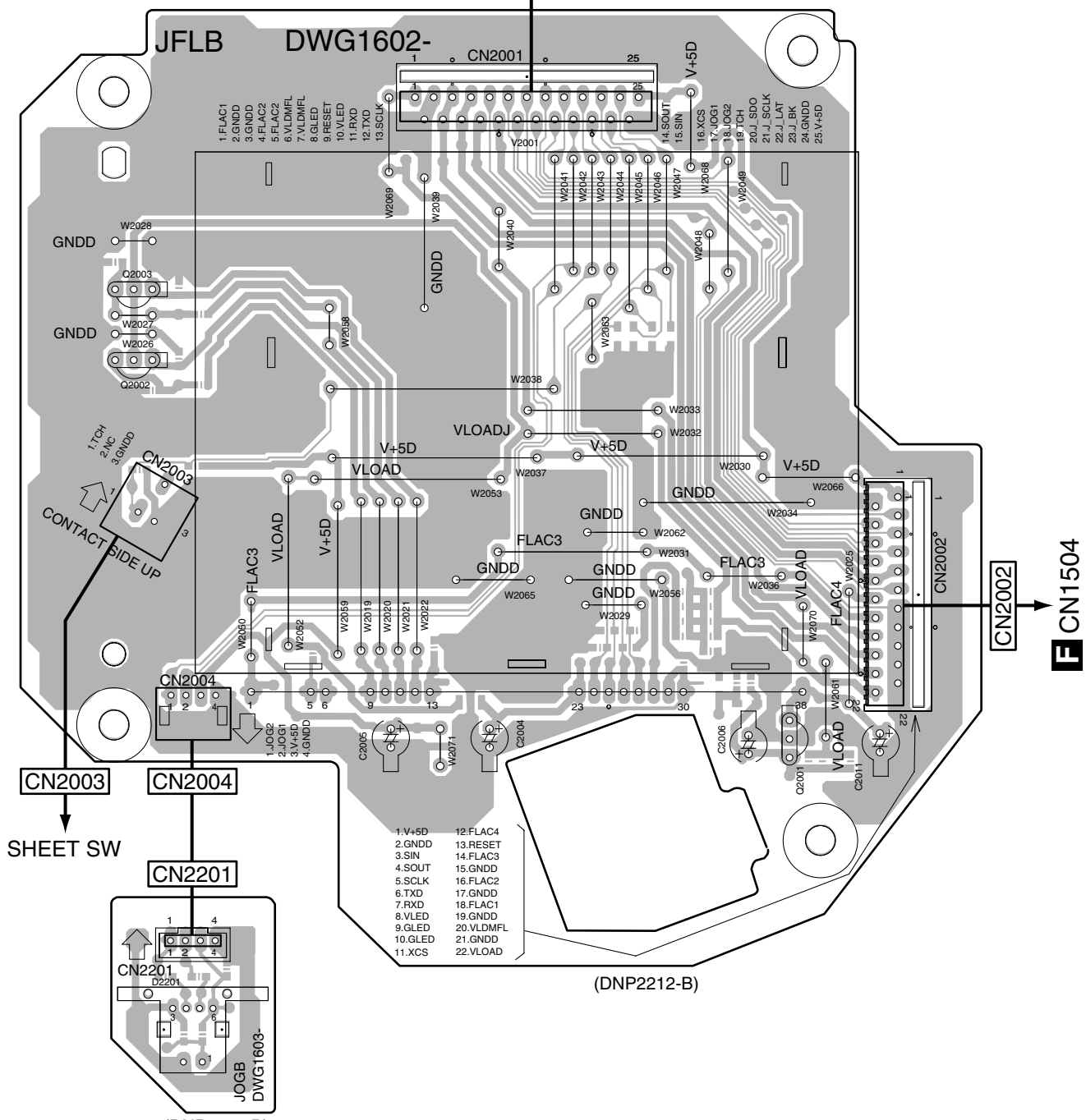

F CN1504

L JOGB ASSY

(DNP2212-B)

(DNP2212-B)

J L

CDJ-1000MK3

4.8 SW POWER SUPPLY ASSY

SIDE A

SIDE A

M SW POWER SUPPLY ASSY

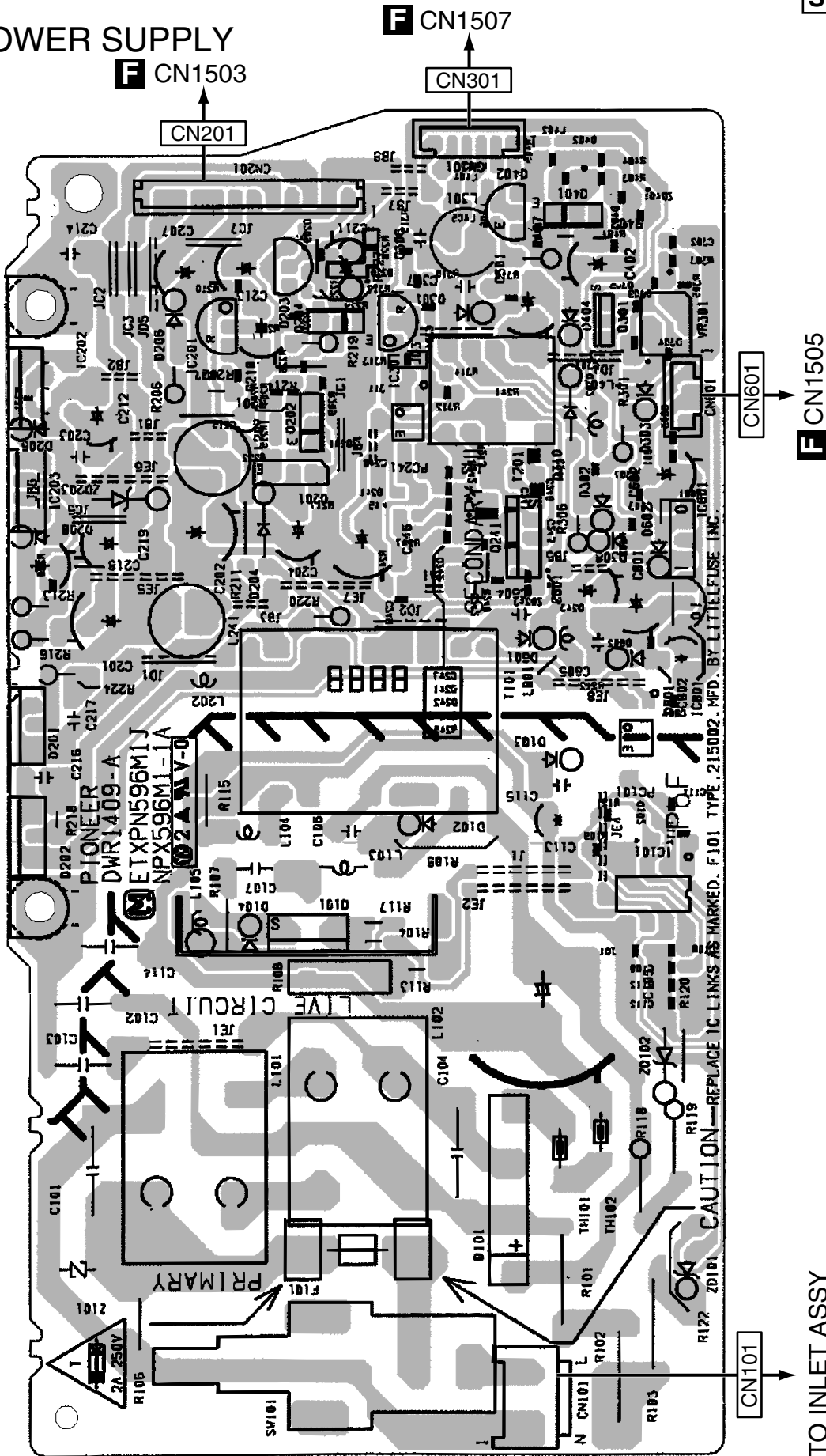

F CN1505

TO INLET ASSY

M

5. PCB PARTS LIST

NOTES: ●Parts marked by "NSP" are generally unavailable because they are not in our Master Spare Parts List.

●The Δ mark found on some component parts indicates the importance of the safety factor of the part. Therefore, when replacing, be sure to use parts of identical designation.

●When ordering resistors, first convert resistance values into code form as shown in the following examples.

Ex.1 When there are 2 effective digits (any digit apart from 0), such as 560 ohm and 47k ohm (tolerance is shown by J=5%, and K=10%).

560 Ω \rightarrow 56 x 10¹ \rightarrow 561 RD1/4PU 561J
 47k Ω \rightarrow 47 x 10³ \rightarrow 473 RD1/4PU 473J
 0.5 Ω \rightarrow R50 RN2H R50K
 1 Ω \rightarrow 1R0 RS1P 1R0K

Ex.2 When there are 3 effective digits (such as in high precision metal film resistors).

5.62k Ω \rightarrow 562 x 10¹ \rightarrow 5621 RN1/4PC 5621F

Mark No. Description Part No.

LIST OF ASSEMBLIES

	1..MAIN ASSY	DWG1591
NSP	1..MFLA ASSY	DWM2223
	2..MJCB ASSY	DWG1605
	2..MFLB ASSY	DWG1606
	2..SLDB ASSY	DWS1367
	3..RSWB ASSY	DWS1368
NSP	1..JFLA ASSY	DWM2224
	2..JFLB ASSY	DWG1602
	2..JOGB ASSY	DWG1603
	2..KSWB ASSY	DWS1365
	3..SLMB ASSY	DWS1366
NSP	1..SUBA ASSY	DWM2225
	2..INSW ASSY	DWS1369
	2..SDCB ASSY	DWX2558
	2..SPCN ASSY	DWX2559
Δ	1..SW POWER SUPPLY ASSY	DWR1409

Mark No. Description Part No.

A MAIN ASSY SEMICONDUCTORS

	IC601	AN22022A
Δ	IC303	BA00HC5FP
Δ	IC605	BA15BC0WFP
	IC602	BD7905BFS
	IC104	BU4230G
	IC402	DSPD56367PV150
	IC103	DYW1752
	IC101	HD6417709SF133B-D
	IC102	K4S281632F-UC75
Δ	IC606	MM1478DFBE
Δ	IC302	MM1592FF
Δ	IC405	MM1661GH
	IC603	MN103S71F
	IC501	PE8001A
	IC604	PEA007A8
	IC107,IC114,IC407	TC74VHC04FTS1
	IC112	TC7SH04FUS1
	IC111,IC113,IC115	TC7SH08FUS1
	IC106,IC406	TC7SZU04FU
	IC502,IC503	TC7WH34FU

	IC403	TE4300PF
	IC401	TMS320DA150PGE16D
	IC301	XC3S50-4TQG144C
	Q603	2SA1577
	Q501	2SD2114K
	Q604	2SJ598-Z
	Q601,Q602	DTC114YK
	Q605	DTC124EUA
	D501	1SS355
	D301-D303,D401	RB551V-30

COILS AND FILTERS

L101	LCYA1R5J2520
------	--------------

CAPACITORS

C602 (22/6.3 V)	CCH1426
C672	CCSRCH101J50
C652	CCSRCH121J50
C457	CCSRCH150J50
C630,C651	CCSRCH151J50
C458	CCSRCH180J50
C516-C518	CCSRCH221J50
C143,C144	CCSRCH7R0D50
C105,C321,C413	CCSSCH471J16
C327,C328,C461,C507,C508	CEHVV101M6R3
C510,C603,C604,C606,C608	CEHVV101M6R3
C611	CEHVV101M6R3
C509,C512,C609,C610	CEHVV470M16
C613,C614	CEHVV470M16
C601,C615	CEHVV470M6R3
C627,C645-C647,C666,C667	CKSRYB102K50
C676,C679,C692	CKSRYB102K50
C659,C682	CKSRYB103K50
C471,C616-C619,C625,C626	CKSRYB104K16
C628,C629,C631,C633-C636	CKSRYB104K16
C639-C642,C644,C656,C660	CKSRYB104K16
C680,C687	CKSRYB104K16
C102,C103,C141,C145,C320	CKSRYB105K6R3
C322,C323,C326,C329	CKSRYB105K6R3
C402-C404,C406,C420,C435	CKSRYB105K6R3
C448,C456,C632,C637,C638	CKSRYB105K6R3
C700-C702,C708	CKSRYB105K6R3
C671	CKSRYB122K50
C675,C678	CKSRYB182K50
C677	CKSRYB222K50

Mark No. Description**Part No.**

C621,C673
C138
C661,C662
A C654,C655,C670
C622,C707

CKSRYB273K16
CKSRYB333K16
CKSRYB471K50
CKSRYB472K50
CKSRYB473K25

C706
C620
C142,C689
C125,C324,C401,C441,C449
C503-C506

CKSRYB474K10
CKSRYB561K50
CKSSYB102K50
CKSSYB103K16
CKSSYB103K16

C101,C104,C106-C116
C118-C124,C126-C133,C137
C146,C151,C301-C319,C330
C405,C407,C411,C412
B C414-C419,C421-C432

CKSSYB104K10
CKSSYB104K10
CKSSYB104K10
CKSSYB104K10
CKSSYB104K10

C436-C440,C442-C447
C450-C452,C501,C502
C513-C515,C663-C665
C668,C669,C681,C684-C686
C688,C690,C691,C695-C699

CKSSYB104K10
CKSSYB104K10
CKSSYB104K10
CKSSYB104K10
CKSSYB104K10

C710
C704,C705
C433
C434,C703

CKSSYB104K10
CKSSYB182K50
CKSSYB333K10
CKSSYB562K25

C RESISTORS

R610,R611,R615-R617 (0.68,1/4 W)
R626,R627,R633 (0.68,1/4 W)
R121,R156,R159,R652
R427,R428,R434
R435,R437,R440,R441

DCN1143
DCN1143
RAB4CQ103J
RAB4CQ223J
RAB4CQ472J

R191,R4452,R4457
R313
R659
R314
R468

RS1/10S0R0J
RS1/16S1001D
RS1/16S1502F
RS1/16S2001D
RS1/16S2701F

D R609
R608
R636,R637
Other Resistors

RS1/4S0R0J
RS1/4SA240J
RS1/4SA2R0J
RS1/16S###J

OTHERS

X101 CRYSTAL RESONATOR
(65.975 MHz)
X401 CERAMIC OSCILLATOR
(16.000 MHz)
X402 CRYSTAL RESONATOR
(16.9344 MHz)

DSS1144
CSS1616
VSS1084

E CN502 CONNECTOR 9P
CN602 13P FFC CONNECTOR
CN604 4P FFC CONNECTOR
CN601 26P FFC CONNECTOR
CN401 13P FFC CONNECTOR

AKM1295
DKN1275
DKN1288
DKN1448
VKN1305

CN501 15P FFC CONNECTOR
CN603 CONNECTOR 2P
CN605 CONNECTOR 3P
CN503 CONNECTOR 6P

VKN1307
VKN1940
VKN1941
VKN1944

F

Mark No. Description**Part No.****B SLMB ASSY
SWITCHES AND RELAYS**

S2401,S2402

DSG1017

OTHERS

CN2401 CONNECTOR 3P

S3B-ZR

C SPCN ASSY**OTHERS**

CN3103 12P FFC CONNECTOR
CN3102 13P FFC CONNECTOR
CN3101 CONNECTOR 2P

DKN1205
DKN1275
VKN1940

**D INSW ASSY
SWITCHES AND RELAYS**

S3301

CSN1031

OTHERS

CN3301 CONNECTOR 2P

VKN1940

**E SDCB ASSY
SEMICONDUCTORS**

D3002,D3004,D3006,D3008
D3001,D3003,D3005,D3007

DAN202K
DAP202K

SWITCHES AND RELAYS

S3001

CSN1068

CAPACITORS

C3004
C3001-C3003

CEVW101M16
CKSRYB104K16

RESISTORS

All Resistors

RS1/16S####J

OTHERS

CN3001 SD CARD SLOT CONNECTOR
CN3002 13P CONNECTOR

DKP3748
VKN1305

**F MJCB ASSY
SEMICONDUCTORS**

△IC1513 (315 mA)
△IC1501 (800 mA)
△IC1502,IC1503 (1.6 A)
△IC1506,IC1514 (2 A)
△IC1507 (4 A)

AEK7003
AEK7008
AEK7012
AEK7013
AEK7018

△IC1504 (200 mA)
△IC1509
IC1512
Q1510
Q1511,Q1512

AEK7023
BA50BC0FP
NJM4580D
2SC2412K
2SC4081

Mark No.	Description	Part No.
△ Q1507		2SD2012
Q1505,Q1506,Q1508,Q1509		2SD2144S
Q1504		DTA124EUA
Q1501-Q1503		DTC124EUA
D1504		1SR154-400
D1505,D1506		1SS355
D1503		NNCD6.2MF
D1501,D1502,D1508		UDZS9R1(B)

CAPACITORS

C1519,C1520,C1523,C1526	CEANP101M10
C1508,C1513	CEAT221M16
C1527	CEAT470M16
C1525	CEHAT101M16
C1524	CEHAT220M63
C1507	CEHAZL100M50
C1515,C1517	CKSRYB103K50
C1509-C1512,C1521	CKSRYB104K16
C1522	CKSRYB104K25
C1514	CKSRYB223K50
C1528,C1529	CQMBA102J50
C1502,C1503,C1505,C1506	CQMBA471J50
C1501,C1504	CQMBA561J50

RESISTORS

R1511,R1532	RD1/2VM103J
R1503,R1508	RD1/2VM113J
R1505,R1506,R1514,R1521	RD1/2VM152J
R1561,R1562	RD1/2VM220J
R1502	RD1/2VM272J
R1504,R1507,R1509,R1510,R1512	RD1/2VM471J
R1519,R1563	RD1/2VM471J
R1516,R1518,R1529,R1531	RD1/2VM473J
R1540	RS1/16S1801F
R1543	RS1/16S3901F
Other Resistors	RS1/16S###J

OTHERS

JA1502 2P PIN JACK (AU)	AKB7164
CN1503 CONNECTOR 11P	B11B-EH
CN1505 CONNECTOR 4P	B4B-PH-K
CN1507 CONNECTOR 6P	B6B-PH-K
CN1506 CONNECTOR 6P	B6B-ZR
CN1501 CONNECTOR 9P	B9B-PH-K
CN1504 22P FFC CONNECTOR	HLEM22S-1
JA1503 1P PIN JACK	PKB1036
JA1501 REMOTE CONTROL JACK	RKN1004
CN1502 15P FFC CONNECTOR	VKN1246

G MFLB ASSY SEMICONDUCTORS

IC1003	BU4242G
△ IC1004	NJM78L05UA
IC1002	PEG237B-K
IC1001	TC7SET08FUS1
Q1016	2SB1237X
Q1001-Q1015	DTC124EUA
D1010	NSPB500-0008
D1007,D1011,D1012,D1014	SLI-343URCW
D1001-D1006,D1009,D1013	SLI-343YCW
D1008,D1017,D1018	SLR-343EBT

Mark No.	Description	Part No.
D1015,D1016		SLR-343MC
D1020		UDZS11(B)
SWITCHES AND RELAYS		
S1013-S1018		DSG1079
S1001		DSH1049
S1002-S1012		VSG1024

CAPACITORS

C1002,C1003	CCSRCH101J50
C1026,C1027	CCSRCH150J50
C1015	CEAT101M16
C1020	CEHAT101M16
C1019	CEHAZL220M50
C1016,C1021-C1024	CKSRYB102K50
C1004,C1006-C1008,C1013,C1014	CKSRYB103K50
C1025	CKSRYB103K50
C1001,C1005,C1009-C1012,C1018	CKSRYB104K16
C1017	CKSRYB104K50

RESISTORS

R1091-R1098	RS1/10S183J
R1063,R1078-R1084	RS1/10S430J
VR1001,VR1002 (10k-B)	DCS1045
Other Resistors	RS1/16S###J

OTHERS

X1001 CRYSTAL RESONATOR (16.0 MHZ)	DSS1149
1004 2P CABLE HOLDER	51048-0200
J1006 9P CABLE HOLDER	51048-0900
J1 JUMPER WIRE 9P	D20PYY0915E
V1001 FL INDICATOR TUBE	DEL1057
FL HOLDER	DNF1744
CN1007 10P FFC CONNECTOR	HLEM10R-1
CN1001 25P FFC CONNECTOR	HLEM25R-1
CN1005 CONNECTOR 6P	S6B-PH-K

H SLDB ASSY SEMICONDUCTORS

Q1201,Q1202	DTC124EUA
D1201	NNCD6.2MF
D1203	SLR-343MC
D1202	SLR-343VC

SWITCHES AND RELAYS

S1201-S1203	VSG1024
-------------	---------

CAPACITORS

C1201	CCSRCH101J50
C1203	CEHAT100M50
C1204,C1205	CKSRYB102K50
C1202	CKSRYB104K16

RESISTORS

VR1202 (1 k)	DCP1105
VR1201	DCV1013
Other Resistors	RS1/16S###J

OTHERS

CN1201 9PJUMPER CONNECTOR	52151-0910
---------------------------	------------

Mark No. Description**Part No.****Mark No. Description****Part No.****I RSWB ASSY
SWITCHES AND RELAYS****L JOGB ASSY
SEMICONDUCTORS**

A	S1301	DSK1021
	OTHERS	
	J1301 2P CABLE HOLDER	51048-0200
	JO JUMPER WIRE 2P	D20PYY0210E

	D2201	GP1A038RBK
	CAPACITORS	
	C2201,C2202	CKSRYB103K50
	RESISTORS	
	All Resistors	RS1/16S###J

J JFLB ASSY**OTHERS****SEMICONDUCTORS**

CN2201 CONNECTOR 4P

B4B-PH-K

B	△IC2001	NJM78L05UA
	Q2001	2SB1237X
	Q2002,Q2003	2SC1815
	D2001	UDZS6R8(B)

M SW POWER SUPPLY ASSY
There is no service parts.**CAPACITORS**

	C2004,C2005,C2011	CEHAT101M16
	C2006	CEHAZL100M50
	C2001	CKSRYB104K16
	C2003	CKSRYB104K50
	C2002	CKSRYB223K25

RESISTORS

C	All Resistors	RS1/16S###J
---	---------------	-------------

OTHERS

	CN2002 FFC CONNECTOR 22P	52492-2220
	CN2001 FFC CONNECTOR 25P	52492-2520
	CN2003 CONNECTOR	CKS1072
	V2001 FL INDICATOR TUBE	DEL1058
	FL HOLDER	DNF1735
	CN2004 CONNECTOR 4P	S4B-PH-K

**D K KSWB ASSY
SEMICONDUCTORS**

	Q2301-Q2303	DTC124EUA
	D2305-D2308	SLI-343YCW
	D2301-D2304	SLR-343EBT
	D2309,D2310	SLR-343MC

SWITCHES AND RELAYS

	S2301,S2302	DSG1079
	S2303-S2306	VSG1024

E CAPACITORS

	C2301-C2303	CCSRCH101J50
--	-------------	--------------

RESISTORS

	All Resistors	RS1/16S###J
--	---------------	-------------

OTHERS

	CN2301 FFC CONNECTOR 10P	HLEM10R-1
--	--------------------------	-----------

F

6. ADJUSTMENT

6.1 TEMPO ZERO POINT ADJUSTMENT



■ Jig

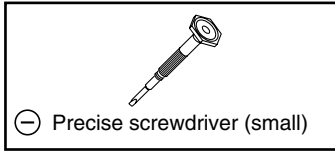

■ Necessary Adjustment Points

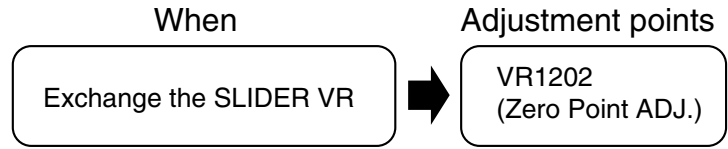

■ Adjustment and Check Points

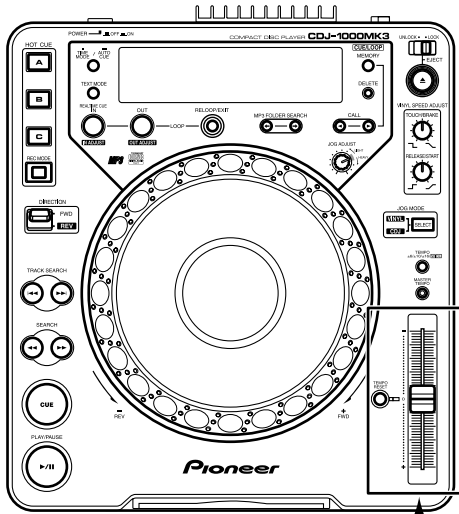

TEMPO knob (SLDB Assy)

Zero Point ADJ.

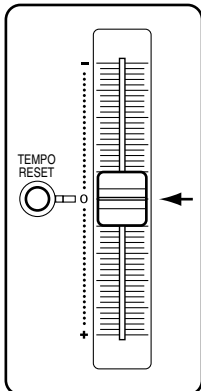

Set the TEMPO knob to the center "0" point.

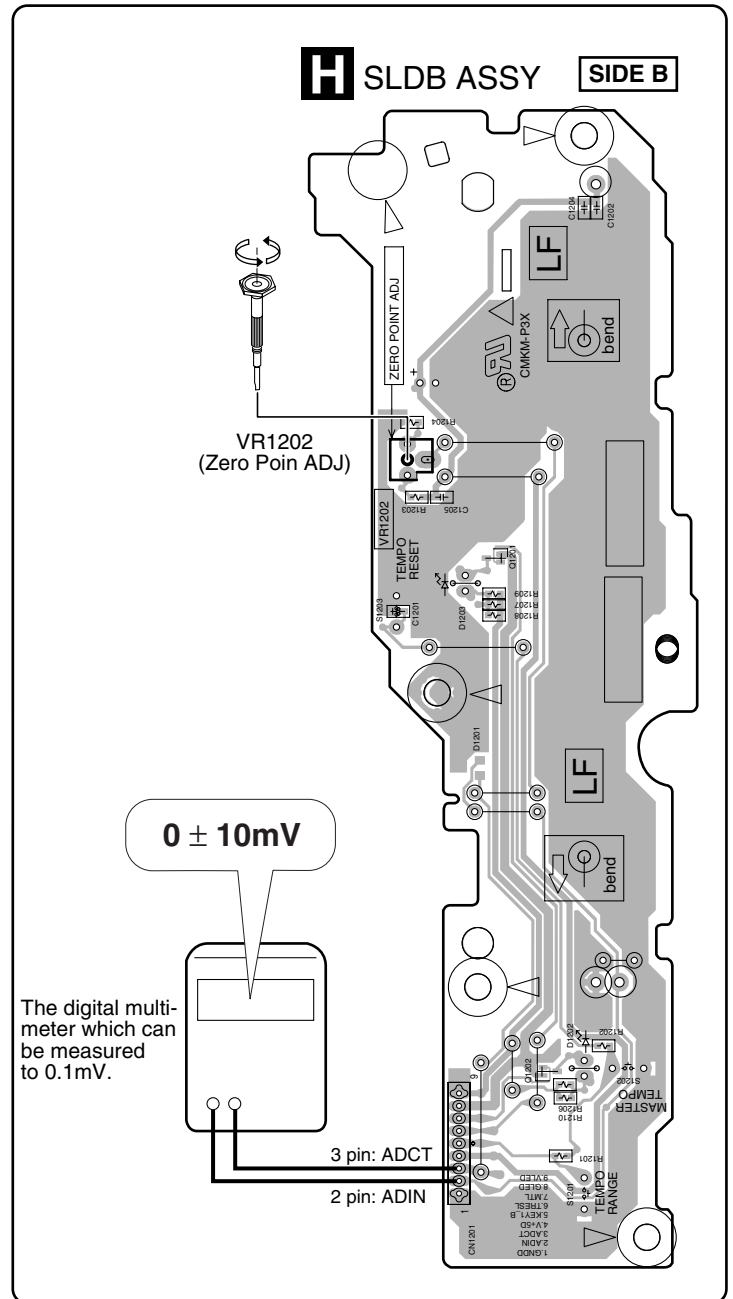
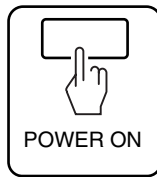

6.2 MODE FOR CHECKING THE LOAD ON THE JOG DIAL

- It is the mode which judges the load (light/-- heavy) numerically when rotating JOG dial.

JOG Check Mode : ON

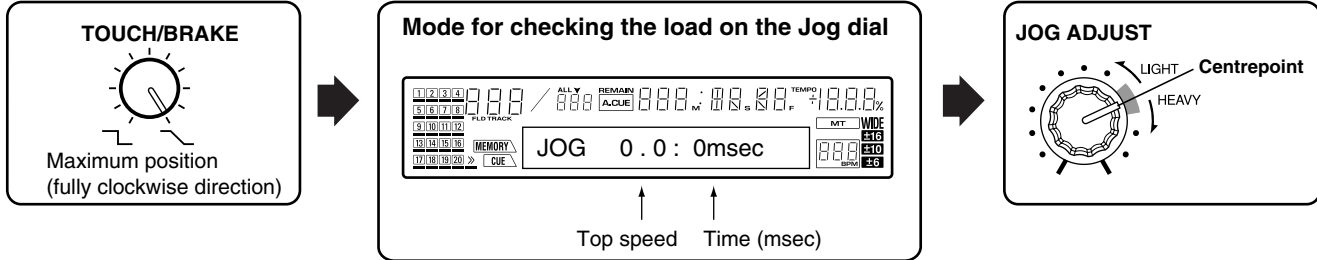

Measuring method

Enter this mode, and a number will be displayed if JOG dial is turned with sufficient vigor. The rotation direction -- clockwise direction and counterclockwise direction -- either is O.K.

For example, when displayed as "JOG 8.6: 115msec", the following contents are shown, respectively.

8.6 = What time speed came out by the highest. (The time of turning one rotation in 1.8 seconds is made into 1 time.)

115 = Time taken for rotation to fall by 1.5 times from 3 times (msec)

It is necessary to make it rotate top speed to 7.0 or more times to measure the rotation fall time required.

When it carries out continuously several times, the time which took the average with a part for greatest ever 4 time is displayed 2nd henceforth.

Measurement which absorbed variation can be performed by performing this.

Jog Management Value : 150 ± 25 (msec) ← It judges by the 3rd measured value.

Load adjustment method

Remove the screw fixing the adjust plate, then screw it into the hole corresponding to the value (-1, -2, -3, +1, or +2) for a load to be added:

-1, -2, -3 : To decrease the load

+1, +2 : To increase the load

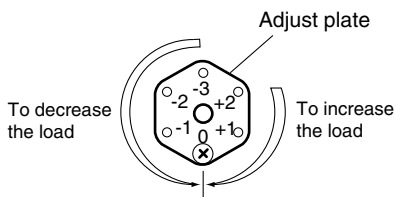

JOG Check Mode : CANCEL

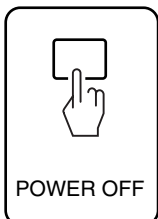

7. GENERAL INFORMATION

7.1 DIAGNOSIS

7.1.1 SERVICE MODE

1. Outline in Service Mode

The unit is provided with three microcomputers: a display microcomputer that controls key input and FL/LED display (operating section), a player microcomputer that drives the player, and a system control microcomputer that controls the whole system. The following test modes are provided for diagnosis of each microcomputer.

① **Mode for checking the version of the software program and error history**

In this mode, the version of the software program for each microcomputer can be checked. And up to 16 error logs can be checked.

② **Mode for checking the buttons in the display section and display functions**

In this mode, buttons and the display function associated with such input can be checked.

③ **Mode for checking the load on the Jog dial**

In this mode, the load on the Jog dial while it is rotated is measured.

④ **Mode for checking the operation of the player simple substance**

In this mode, operation check of the mechanism and servo of the Player section. This mode consists of "Player operation mode" and "Test operation mode."

2. Mode for checking the version of the software program and error history

In this mode, the version of the software program for each microcomputer and the error history can be checked.

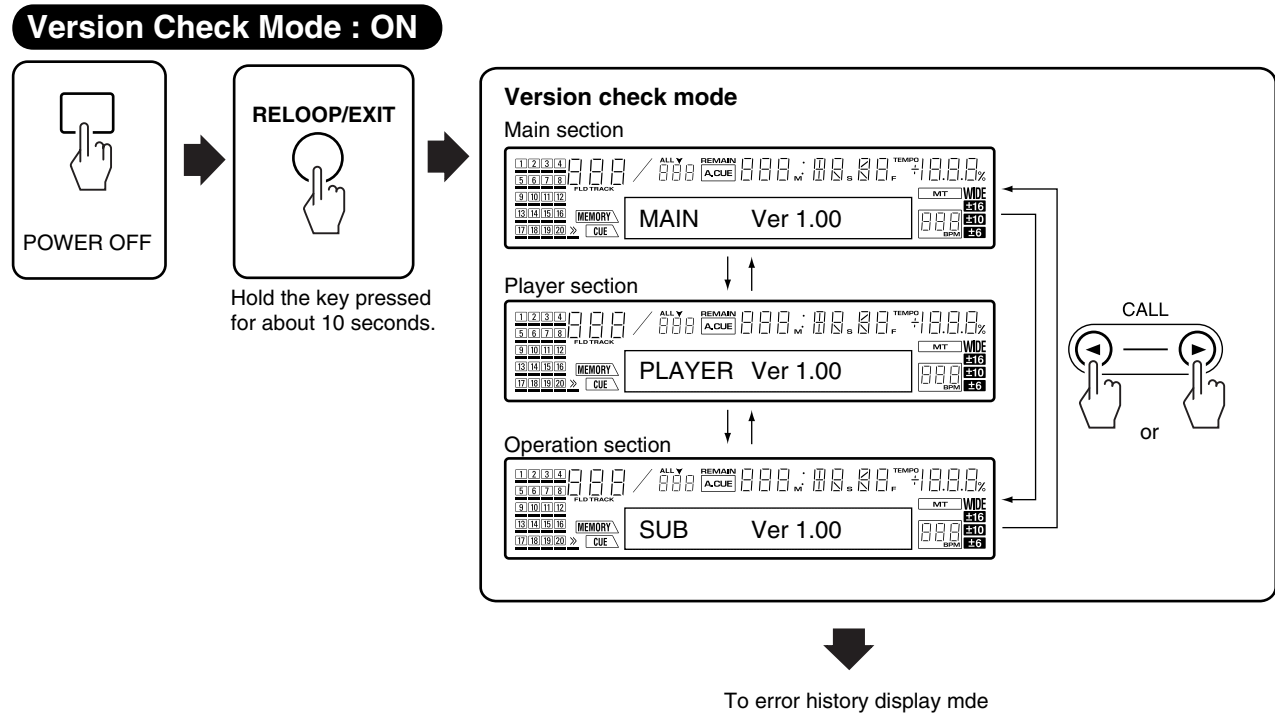

A

From version check mode

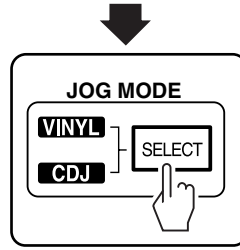

B

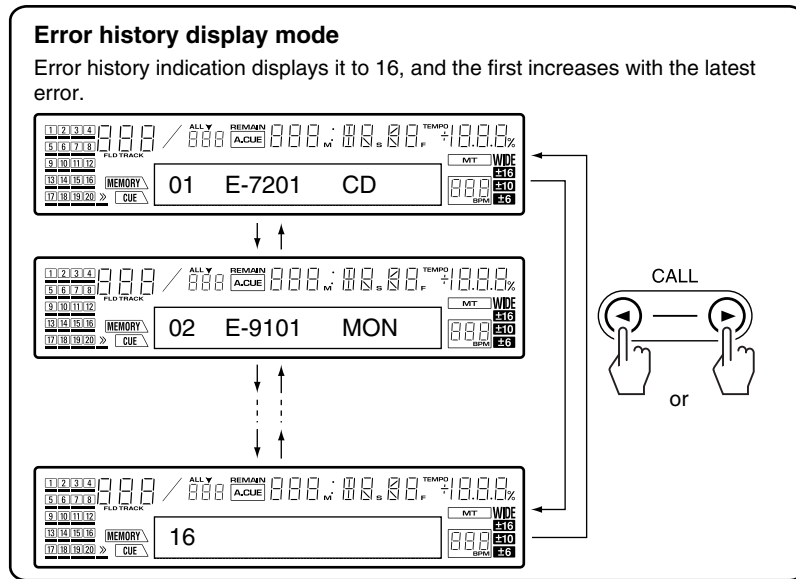

C

Version Check Mode : CANCEL



D

List of error codes

Error Code	Error Description	Remarks
E-7001	ATAPI system (drive) error	Unrecoverable: Turn the power off. The error indication will be cleared.
E-7002	DMA FPGA device error	Unrecoverable: Turn the power off. The error indication will be cleared.
E-7010	TI DSP device error	Unrecoverable: Turn the power off. The error indication will be cleared.
E-7011	MOT DSP device error	Unrecoverable: Turn the power off. The error indication will be cleared.
E-7012	TE4300 device error	Unrecoverable: Turn the power off. The error indication will be cleared.
E-7015	FPGA download error	Unrecoverable: Turn the power off. The error indication will be cleared.
E-7101	Exception interrupt outbreak error	Unrecoverable: Turn the power off. The error indication will be cleared.
E-7201	TOC not readable	The error indication is cleared when the EJECT process is finished.
E-8301	Error during startup	The error indication is cleared when the EJECT process is finished or startup is completed successfully.
E-8302	Error during playback	The error indication is cleared when the EJECT process is finished or startup is completed successfully.
E-8303	Other error of the player section	The error indication is cleared when the EJECT process is finished or startup is completed successfully.
E-8304	MP3 decode error	Display it in search for two seconds. Reproduction is continued by possible data.
E-8305	MP3 data format error	The error indication is cleared when the EJECT process is finished or startup is completed successfully.
E-8709	Communication error between operatin section and main section	The error indication is cleared when the communication is finished .
E-8709	Error in mechanical operations	Unrecoverable: Turn the power off. The error indication will be cleared.

F

Notes: E-8304, E-8305 and E-8709 are not stored into the internal memory.

3. Mode for checking the buttons in the display section and display functions

Display Check Mode : ON

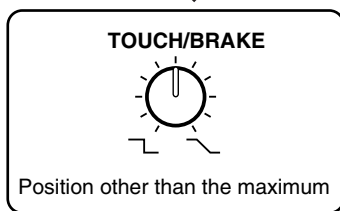
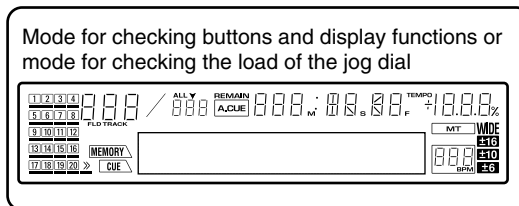
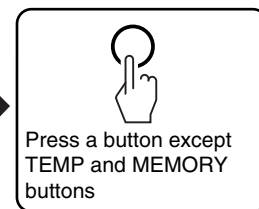
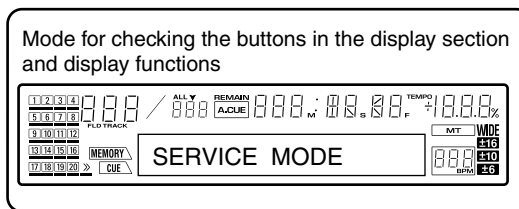
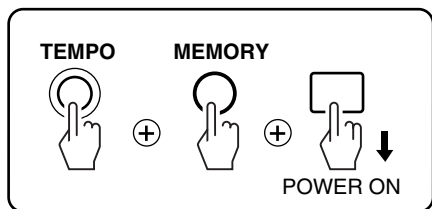

It will become the check mode of buttons and display functions, and if each button is pressed, FL display and LED which correspond light up.

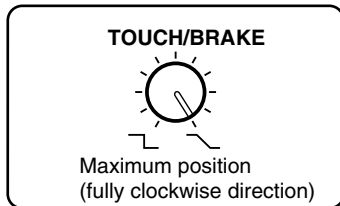

It will become JOG load check mode, and top speed and time will be displayed on a FL dot-matrix part.

Display Check Mode : CANCEL

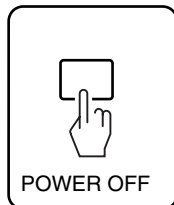

Display Check

Button and Switch	FL Dot-matrix Display	FL Other Display	Light up LED
① PLAY/PAUSE	PLAY		① PLAY/PAUSE
② CUE	CUE		② CUE
③ IN/REALTIME CUE	IN		③ IN/REALTIME CUE
④ OUT/OUT ADJUST	OUT		④ OUT/OUT ADJUST
⑤ RELOOP/EXIT	RELOOP		⑤ RELOOP
⑥ FOLDER ←	FOLDER ←	⑥ 15G lights up	
⑦ FOLDER →	FOLDER →	⑦ 16G lights up	
⑧ TRACK (←←)	TRACK ←←	⑧ 14G lights up	
⑨ TRACK (→→)	TRACK →→	⑨	
⑩ REV (←←)	REV ←←	⑩	
⑪ FWD (→→)	FWD →→	⑪	
⑫ HOT CUE (A)	HOT CUE A		⑫ HOT CUE (A), (B), (C) Red
⑬ HOT CUE (B)	HOT CUE B		⑬ HOT CUE (A), (B), (C) Green
⑭ HOT CUE (C)	HOT CUE C		⑭ HOT CUE (A), (B), (C) Orange
⑮ REC MODE	REC MODE		
⑯ JOG MODE	JOG MODE	⑯	⑯ VINYL
⑰ TEMPO	TEMPO		⑰ CDJ
⑱ MASTER TEMPO	MASTER TEMPO		⑱ MASTER TEMPO
⑲ TEMPO RESET	TEMPO RESET		⑲ TEMPO RESET
⑳ TIME MODE/AUTO CUE	TIME/ACUE		
㉑ TEXT MODE	TEXT/WAVE		
㉒ DELETE	All FL lights up	All FL lights up	All LED lights up *Note
㉓ MEMORY	MEMORY		㉓ CARD
㉔ EJECT	EJECT		
㉕ CUE/LOOP CALL ◀	CALL ◀		
㉖ CUE/LOOP CALL ▶	CALL ▶		
㉗ TOUCH SENSOR	TOUCH SW	㉗	
㉘ JOG rotating to FWD	JOG >		
㉘ JOG rotating to REV	< JOG		
㉙ DIRECTION Reverse			㉙ REV
㉚ EJECT LOCK	lock		

* **Notes:** As for HOT CUE button LED, as for HOT CUE(A), red, HOT CUE(B) are green, and LED of an orange turns on HOT CUE(C).

• **A display of TOUCH/BRAKE, RELEASE/START and TEMPO slider reading value**

In the following area of FL indication department, a bar displays TOUCH/BRAKE, RELEASE/START, a TEMPO slider reading value.

MEMORY Area : If a TOUCH/BRAKE knob is turned to the clockwise direction, the number of display dots will increase.

CUE Area : If a RELEASE/START knob is turned to the clockwise direction, the number of display dots will increase.

Playing Address : If a TEMPO slider knob is moved to + side, the number of display dots will increase.

• Upper Panel

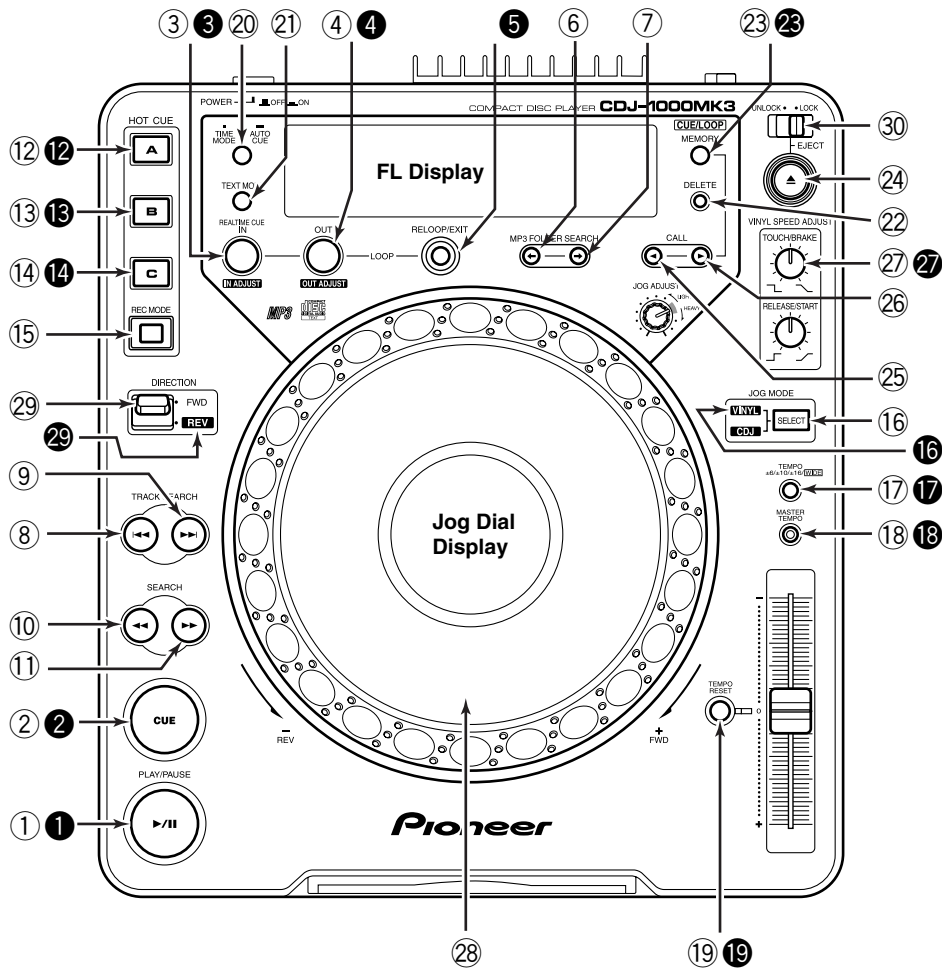

• FL Display

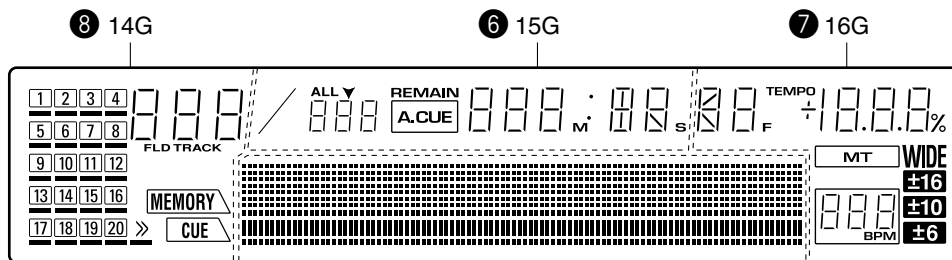

• Jog Dial Display

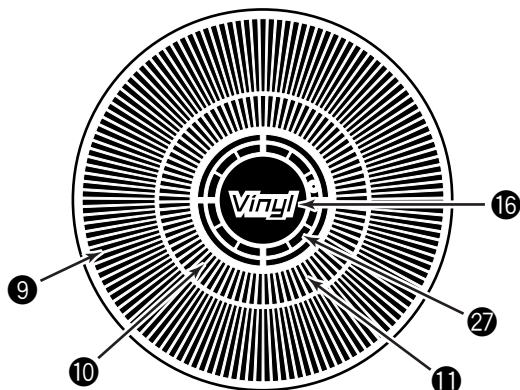

4. Mode for checking the operation of the player simple substance

This mode consists of "Player operation mode" and "Test operation mode."

Player operation mode: ON

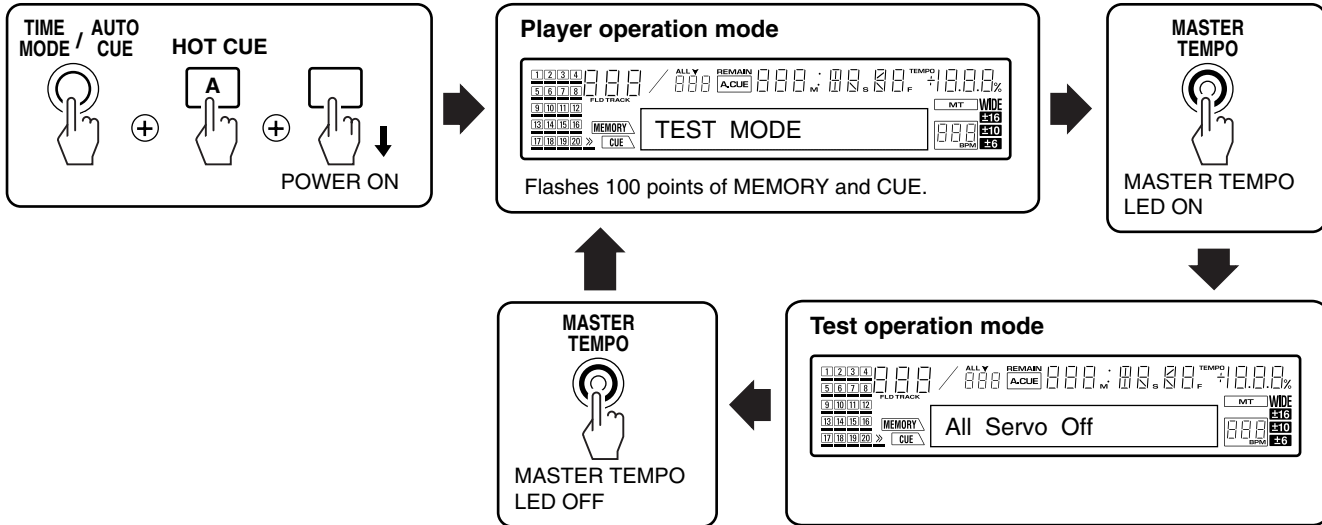

Player operation mode: CANCEL



<Player operation mode>

Basic operation of the servo, such as setup, play, pause, and track search, is carried out. Moreover, measurement of an error rate can also be performed.

<Test operation mode>

Servo operation is finely controllable gradually.

* It becomes player operation mode and shifts to test operation mode by the key input in the beginning.

* The command treated here is for mainly testing a mechanism and a servo system, and is not for DJ functions, such as scan and tempo.

• Player operation mode

Function	Button of the Main Unit
Play(trace) / Pause	PLAY/PAUSE
Track Search F/R	TRACK SEARCH ►►/◄◄
Error Rate Count	CUE
Eject	EJECT
Mode Change	MASTER TEMPO

• Test operation mode

Function	Button of the Main Unit
Servo All Off	TIME
Slider Move Fwd	SEARCH ►►
Slider Move Rev	SEARCH ◄◄
Step Command	FOLDER SEARCH ◄/►
Mode Change	MASTER TEMPO

• Commands in Player Operation mode

Play (trace)/Pause

If the unit is in Stop mode when this command is issued, the unit is set up, the PLAY/PAUSE button lights, then playback starts. If the unit is in Playback mode, it enters Pause mode. If in Pause mode, it releases Pause mode then restarts playback. When a CD is played, the progress of signal trace and track number are indicated on the FL display.

Note: In this mode, auto setup will not be performed even if a disc is loaded. Playback does not mean audio playback but tracing of the signal surface of a disc. In playback, tracing is performed at 4000 rpm CAV.

Track Search F/R

For a CD, the displayed track is searched in the forward or reverse direction, then the unit will pause.

Note: When a CD-ROM (MP3) is used, track search cannot be performed.

Error Rate Count

For a CD, the error rate is measured for about 20 seconds from the current playback/pause position, then the result is displayed on the FL display. Normally, you would search the track for which you wish to measure the error rate, pause the unit, then press the CUE button. The result of measurement will be displayed, for example, as "3.56E-4 OK."

If the error rate is 3.00E-3 or less, that CD is judged okay. If it is greater than 3.00E-3, the CD is considered defective.

The parameter is derived from the results of measurements with control discs at the factory.

This function must not be used for judgment of failure of a product during servicing.

Eject

To eject a disc.

Mode Change (to shift to Test Operation mode)

When the MASTER TEMPO button is pressed during normal player operation, the MASTER TEMPO LED lights. Playback is stopped, and the unit shifts to Test Operation mode, described below. "All Servo Off" is displayed on the FL display.

• Commands in Test Operation mode

Servo operations can be controlled step by step. Care must be taken when using a command in Test Operation mode, because a wrong command may damage the player.

Servo All Off

When the TIME button is pressed during Servo ON, all the servos are shut off.

"All Servo Off" is displayed on the FL display while the TIME button is held pressed. If it is held pressed for less than 1 second, the indication will remain displayed for 1 second.

Slider Move Fwd

Each time the SEARCH FWD button is pressed, the slider moves about 1.8 mm outward.

"Slider Move Fwd" is displayed on the FL display while the SEARCH FWD button is held pressed. If it is held pressed for less than 1 second, the indication will remain displayed for 1 second.

Slider Move Rev

Each time the SEARCH REV button is pressed, the slider moves about 1.8 mm inward.

"Slider Move Rev" is displayed on the FL display while the SEARCH REV button is held pressed. If it is held pressed for less than 1 second, the indication will remain displayed for 1 second.

Step command

A series of operations for startup will be performed step by step.

Each time the FOLDER SEARCH FWD button is pressed, the step is advanced. Each time the FOLDER SEARCH REV button is pressed, the step is reversed. Each step and its operation is shown in the table below:

A

Step	Operation	FL Display
STEP0:	Servo All Off	All Servo Off
STEP1:	Laser diode on	STEP1 LD
STEP2:	Disc presence judgment	STEP2 D.SENSE
STEP3:	Spindle on (2000rpm)	STEP3 SPDL
STEP4:	Disc search	STEP4 D.SRCH
STEP5:	Focus serve on	STEP5 FCS
STEP6:	Focus position coarse adjustment	STEP6 F.POS
STEP7:	Tracking balance adjustment	STEP7 T.BAL
STEP8:	Tracking servo on	STEP8 TRK
STEP9:	Focus position adjustment	STEP9 F.POS
STEP10:	Focus gain adjustment	STEP10 F.GAIN
STEP11:	Tracking gain adjustment	STEP11 T.GAIN
STEP12:	Address lead start	STEP12 READ

FOLDER SEARCH FWD button : step up
 FOLDER SEARCH REV button : step down

"All Servo Off" is displayed for about 1 second. The indications for steps 1 to 12 are displayed on the FL display until the next step is entered.

Mode Change (termination of Test Operation mode)

When the MASTER TEMPO button is pressed during Test Operation mode, the MASTER TEMPO LED goes dark, the servo is stopped, then the unit shifts to Player Operation mode, described above.

D

E

F

7.1.2 HOW TO UPGRADE THE SOFTWARE OF THE MICROCOMPUTER

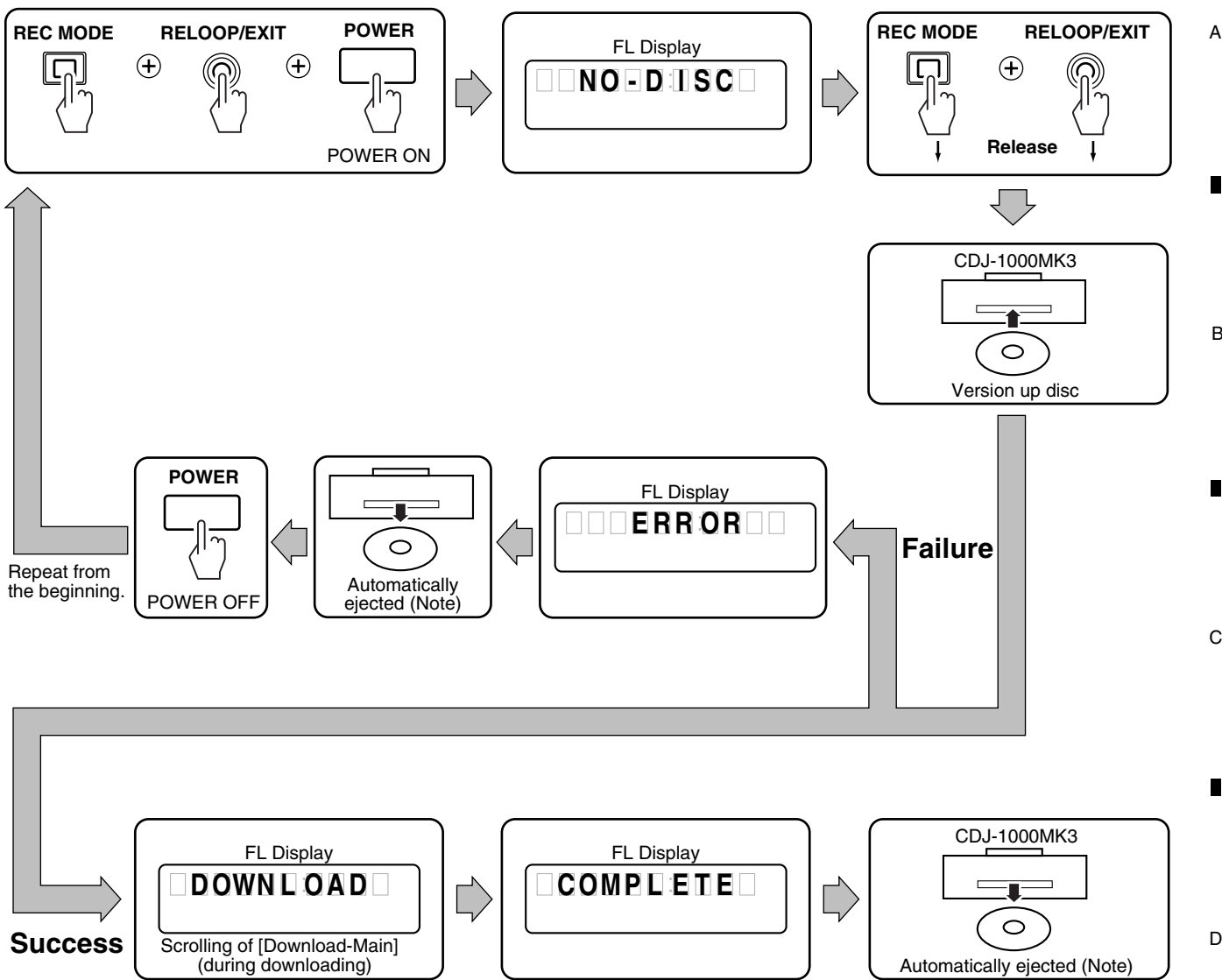

Note:

- Do NOT turn off the power after the upgrade disc is loaded till it is automatically ejected. If you do, the unit may not operate properly afterward.
- Eject a disc automatically even if updating fails.

7.1.3 SEQUENCE

● Power On Sequence

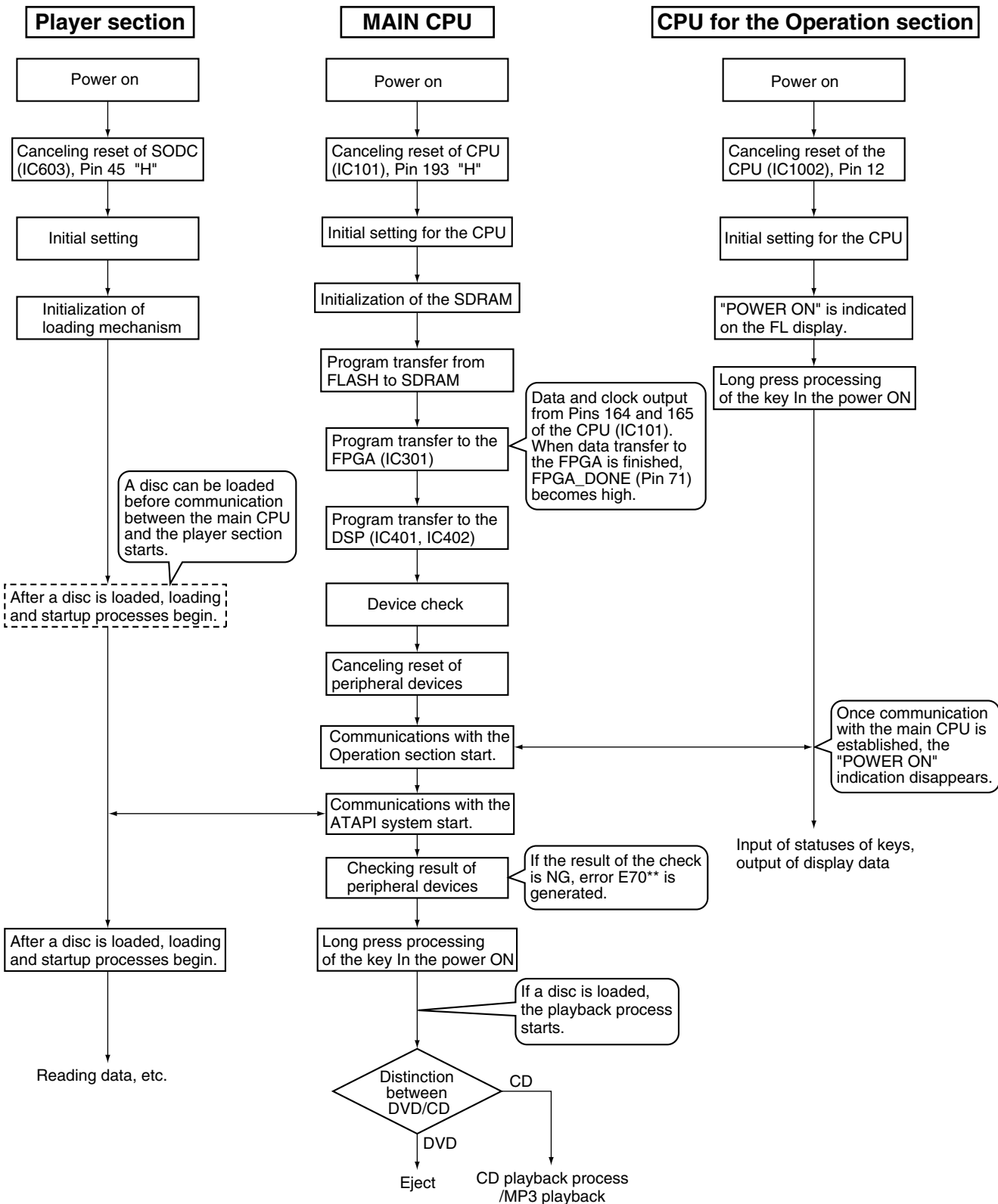

● Sequence of Starting Up the Drive

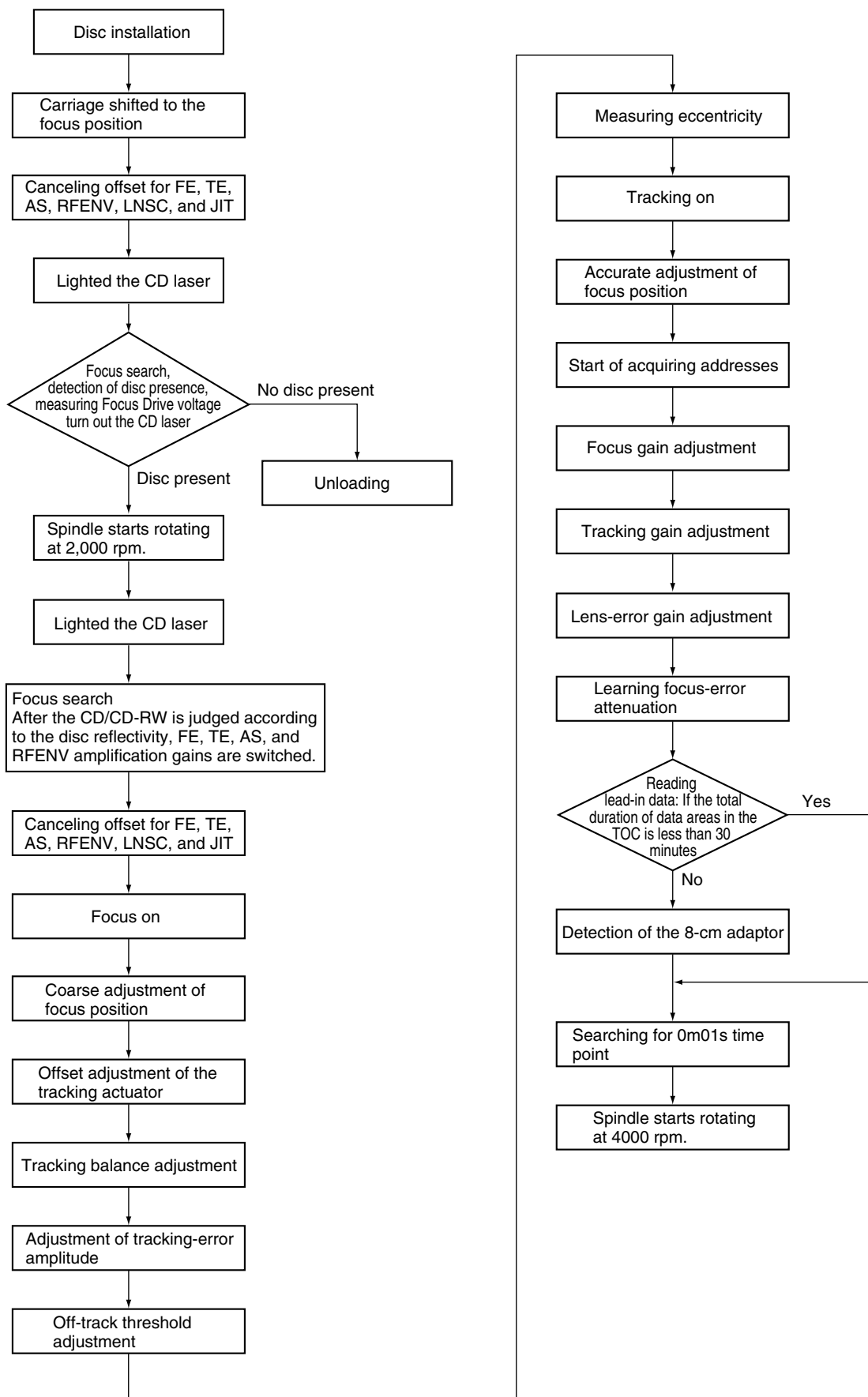

7.1.4 DISASSEMBLY

Note 1: Do NOT look directly into the pickup lens. The laser beam may cause eye injury.
Note 2: Even if the unit shown in the photos and illustrations in this manual may differ from your product, the procedures described here are common.

PCB Location

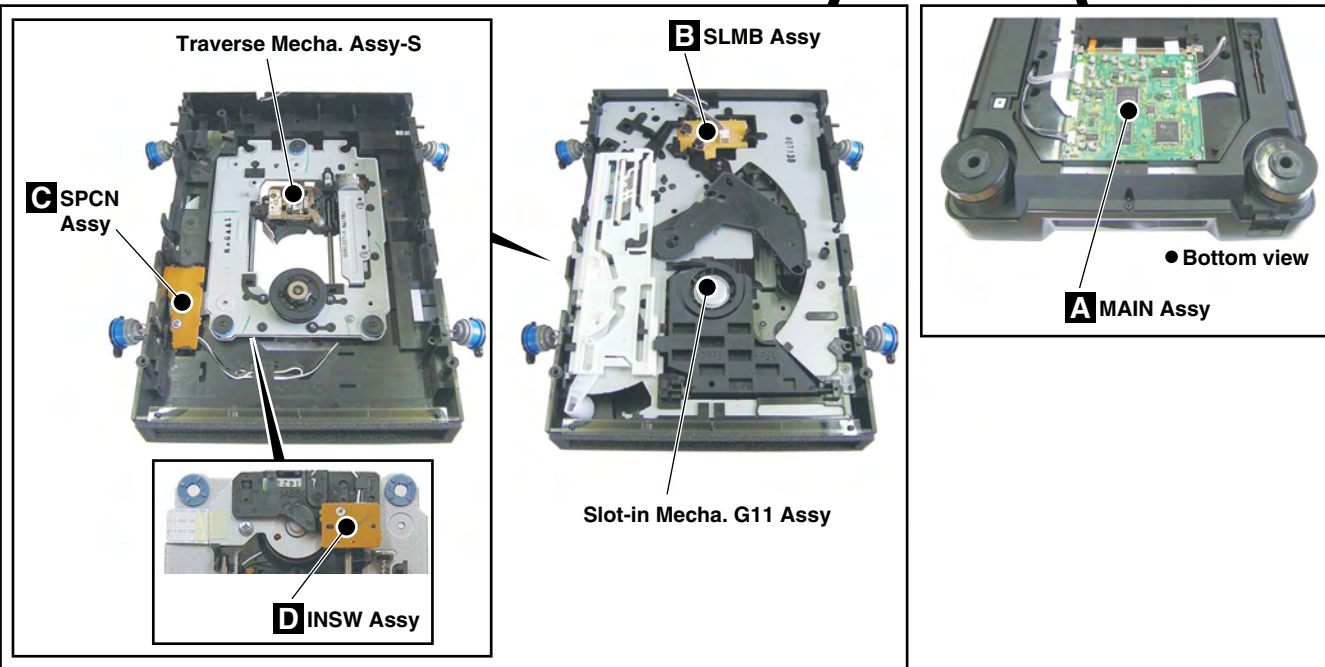
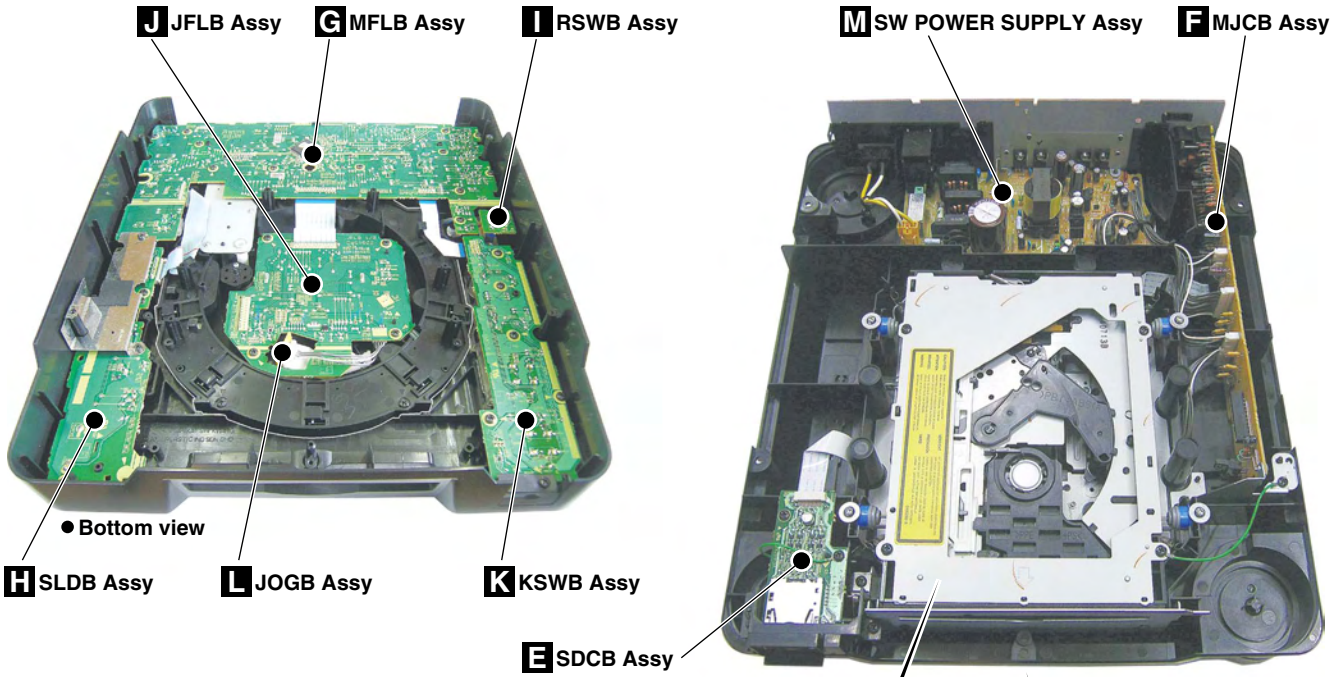

Diagnosis of MAIN Assy

- ① Remove the seven screws.
- ② Remove the bottom plate.

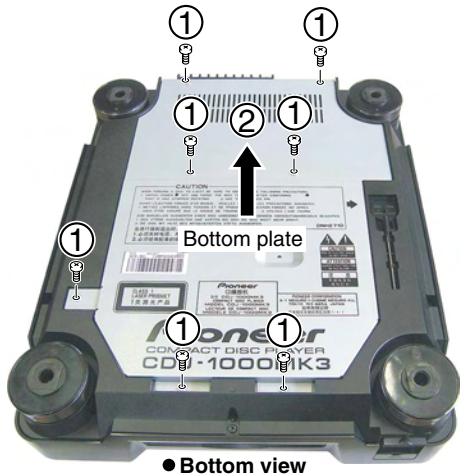

- ③ Remove the four screws.

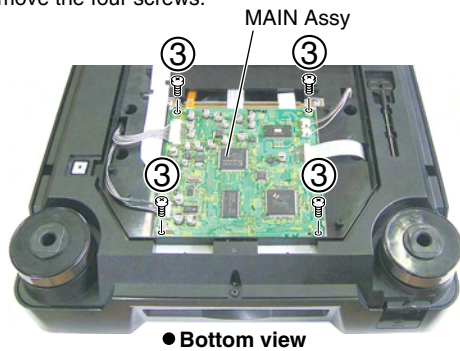

- ④ Stand the MAIN Assy.

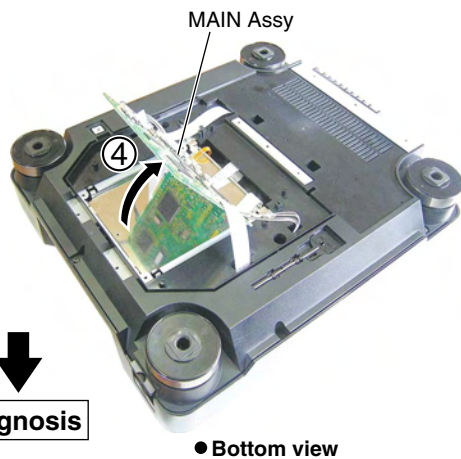

Note:
If diagnosis of the SD card block is not required, the diagnostic procedures can be performed with the MAIN Assy kept in the upright position. Continue to Steps 5 through 7.

- ⑤ Stand the MAIN Assy.
- ⑥ Disconnect the flexible cable: (CN401).
- ⑦ Set the MAIN Assy in the upright position, by engaging it at the two hooks.

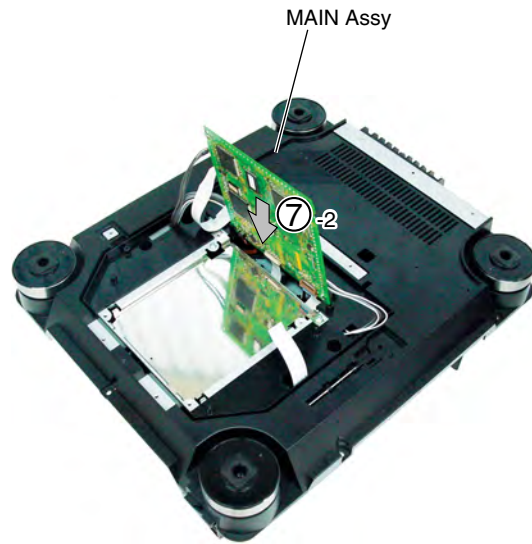
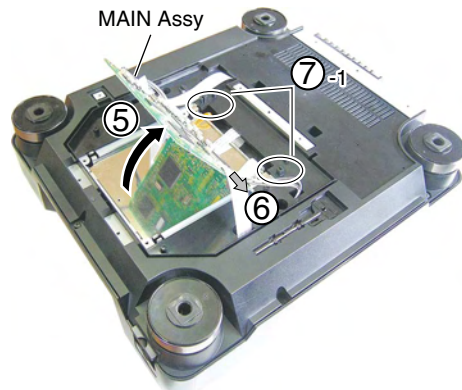

Diagnosis

A Disassembly

1 Control Panel Section

① Remove the one screw.

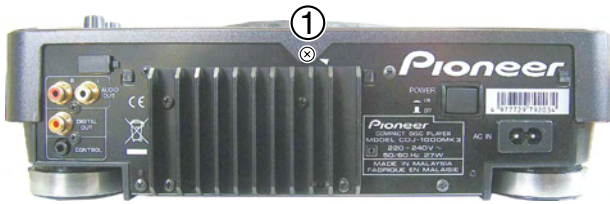

● Rear view

② Remove the five screws.



● Bottom view

③ Remove the control panel section.

Control panel section

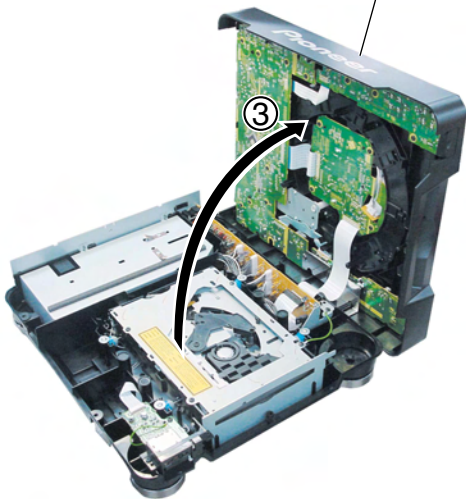

2 Slot-in Mecha. Section

① Remove the control panel section.
(Refet to "Control panel section".)

② Remove the seven screws.

③ Remove the bottom plate.

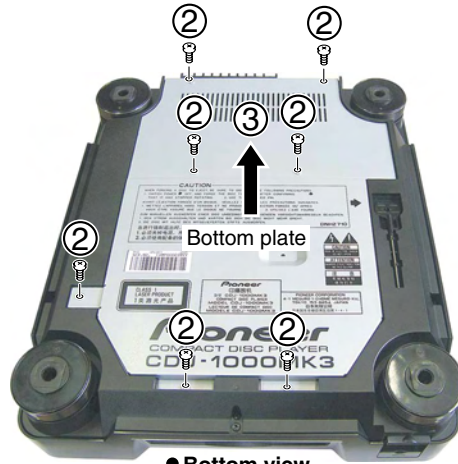

● Bottom view

④ Remove the four screws.

MAIN Assy

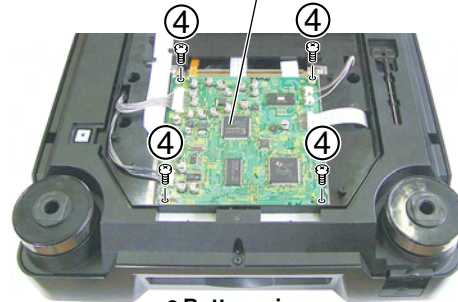

● Bottom view

⑤ Stand the MAIN Assy.

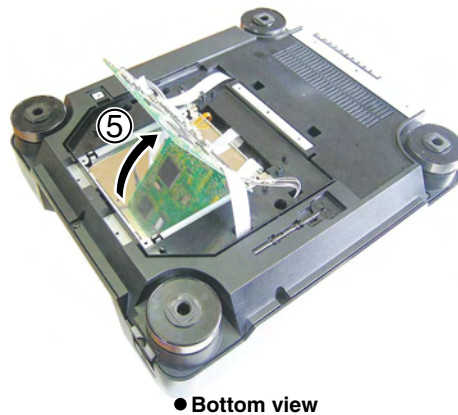

● Bottom view

- ⑥ Stand the MAIN Assy.
- ⑦ Disconnect the flexible cable (CN401).
- ⑧ Set the MAIN Assy in the upright position, by engaging it at the two hooks.

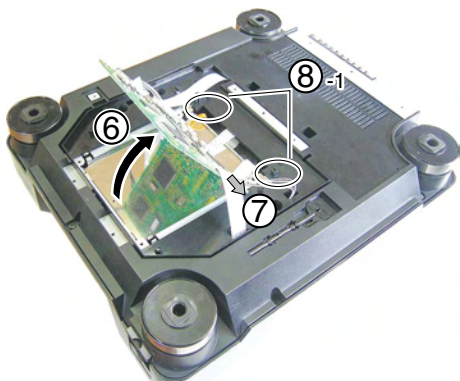

● Bottom view

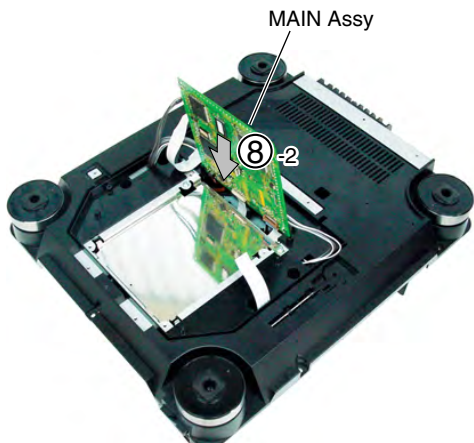

● Bottom view

- ⑨ Remove the two screws.
- ⑩ Remove the shield case.

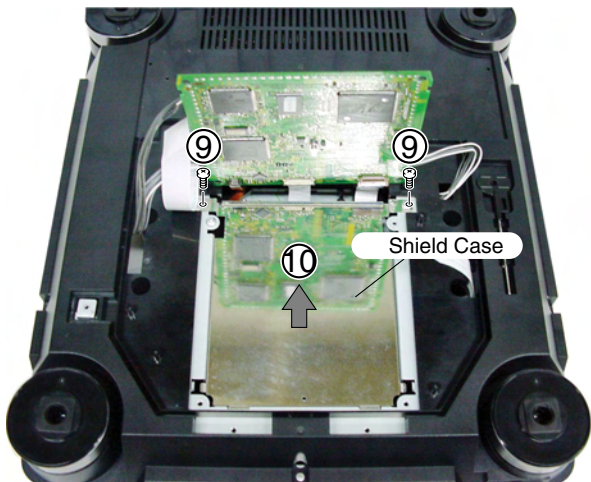

- ⑪ Short-circuit two points of C and D soldering.

Note: After replacement, connect the flexible cable, then remove the soldered joint (open).

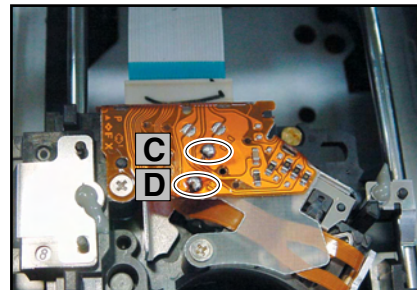

- ⑫ Disconnect the two connectors.

- ⑬ Disconnect the three flexible cables.

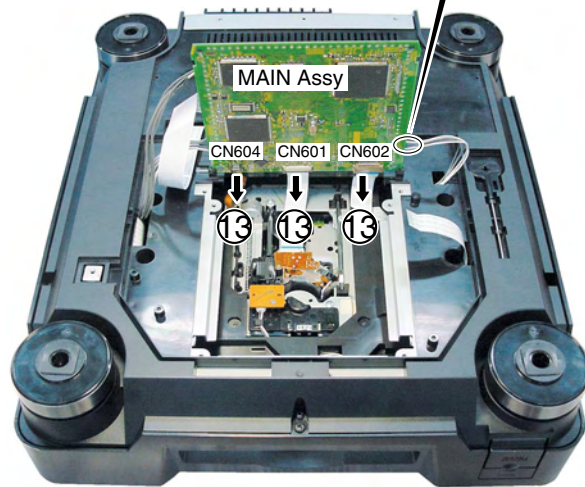
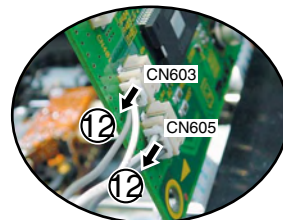

● Bottom view

A

- ⑭ Remove the earth lead unit by removing the one screw.
- ⑮ Remove the four DM screws.

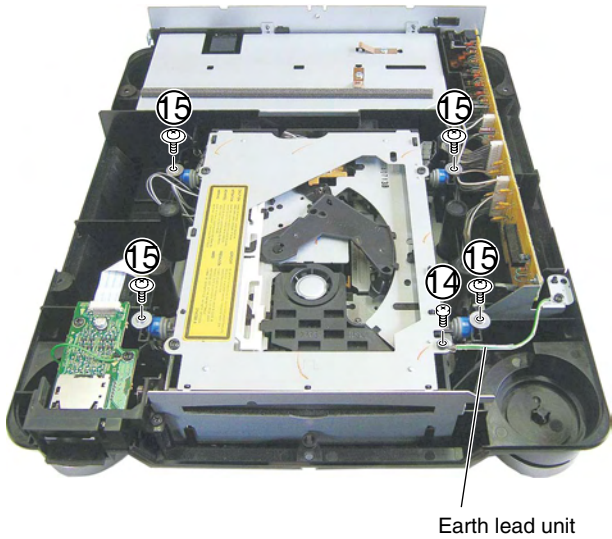

B

C

- ⑯ Remove the four float spring G5s.
- ⑰ Remove the slot-in mecha. section.

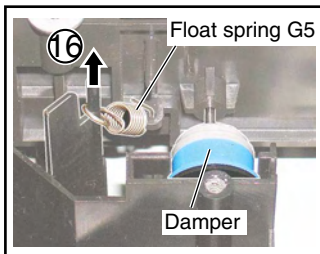

D

E

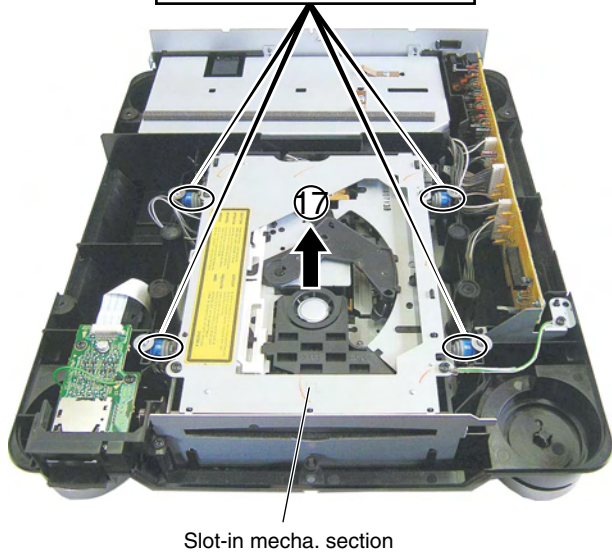

F

3 Traverse Mecha. Assy-S

- ① Remove the three screws.
- ② Remove the mecha. plate.

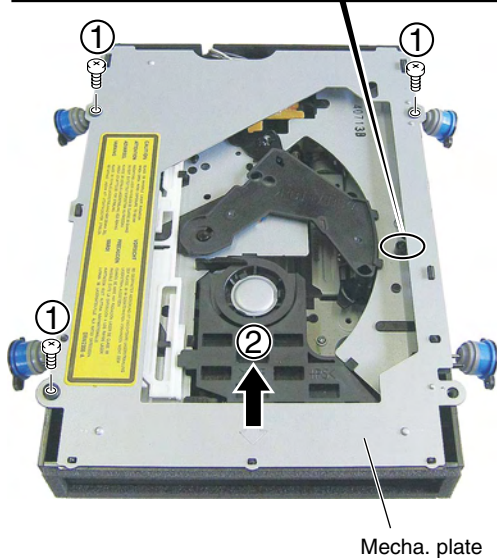
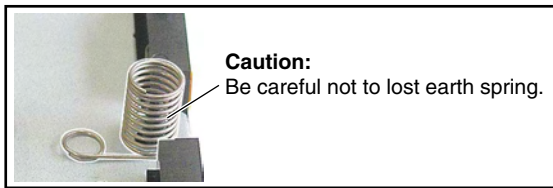

- ③ Unhook the four hooks.
- ④ Remove the slot-in mecha. G11 Assy.

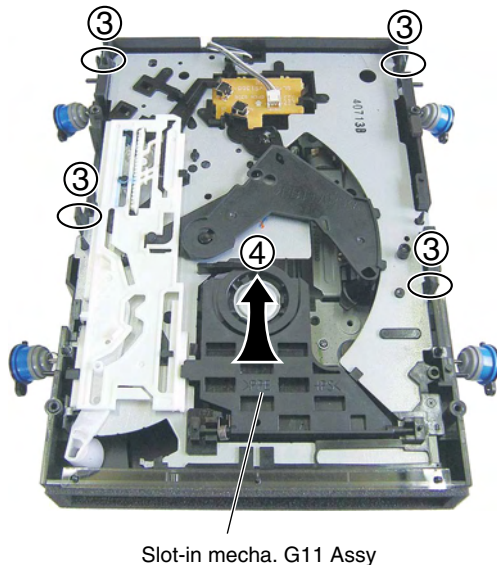

Slot-in mecha. G11 Assy



- ⑤ Remove the three float screws.
- ⑥ Remove the traverse mecha. Assy-S.

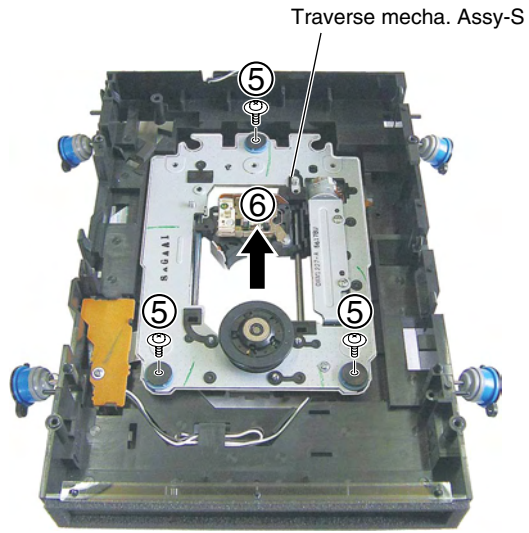

Traverse mecha. Assy-S



Before shipment, be sure to clean the pickup lens, using the following cleaning materials:

- Cleaning liquid : GEM1004
- Cleaning paper : GED-008

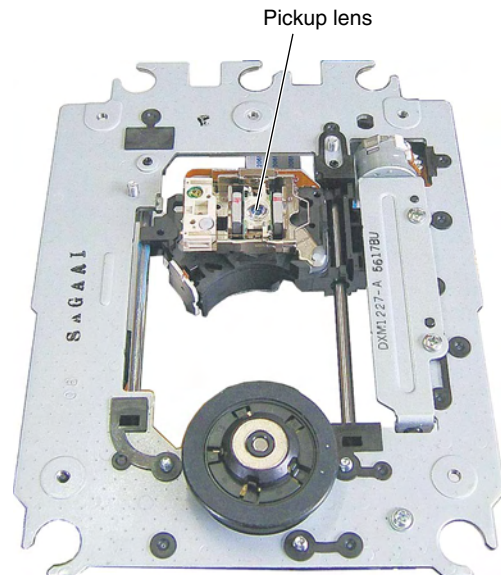

Pickup lens

4 JOG Section

① Remove the adjust knob.



② Disconnect the flexible cable.

③ Remove the five screws.

④ Remove the JOG section.

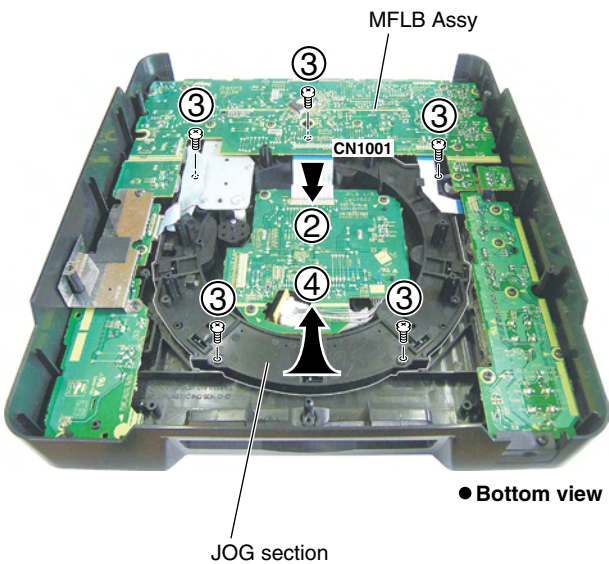

⑤ Remove the two screws.

⑥ Remove the JOG A and JOG Bs.

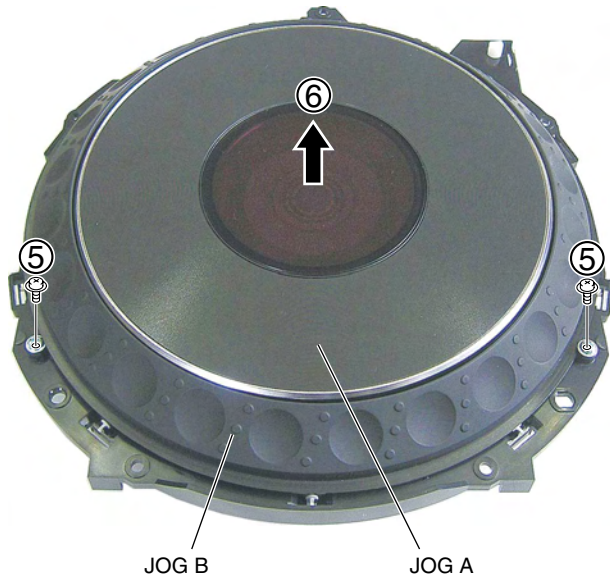

⑦ Remove the three screws.

⑧ Remove the SW ring.

Caution:
Be careful not to lost SW spring 25.

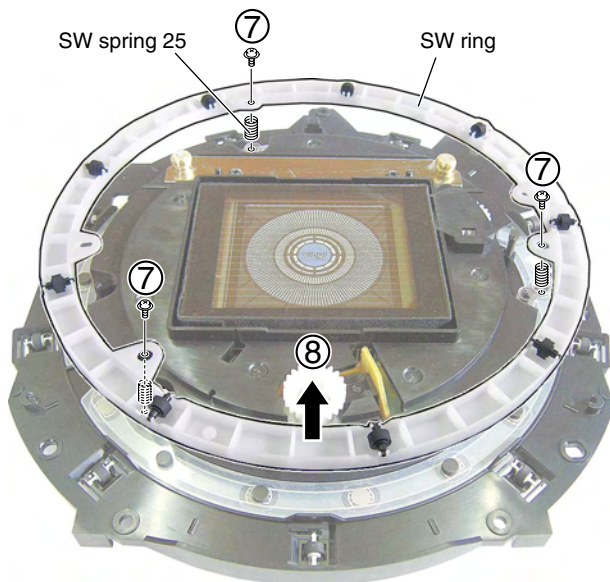

Notes on Replacement

Positioning of the JOG ADJ. mechanism

Note: When reassembling the JOG ADJ. mechanism, be sure to perform positioning, as shown below:

- ① Mount the joint gear 1.
- ② Align the projection of JOG holder 1000 (▶) with the arrow head (◀) on joint gear 1.

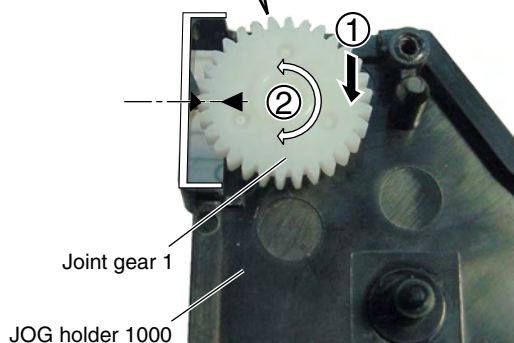
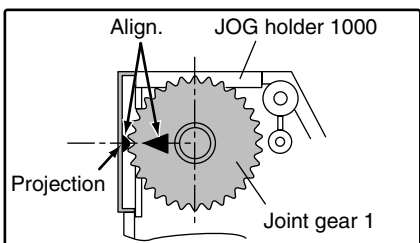

- ③ Mount the cam plate on place it so that the slit of the cam plate aligns with the gear stopper.

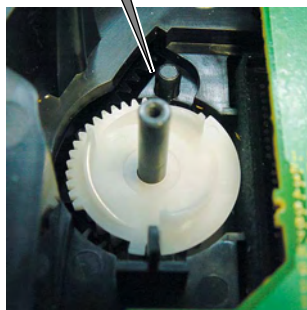
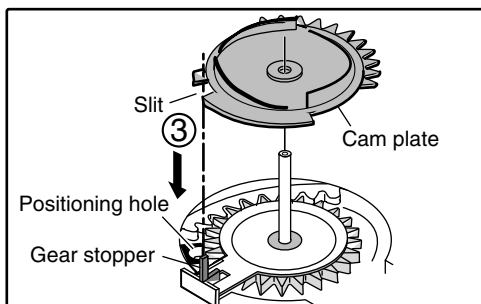

- ④ Turn the cam plate clockwise until the slit aligns with the positioning hole.
- ⑤ Insert the forced eject pin through the positioning hole to immobilize the cam plate.

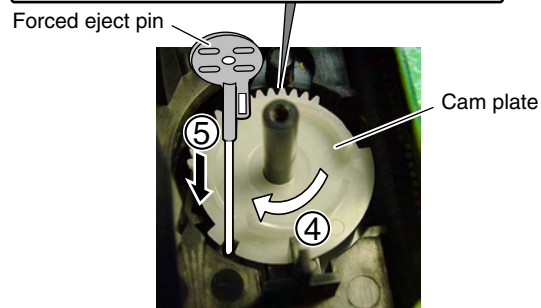
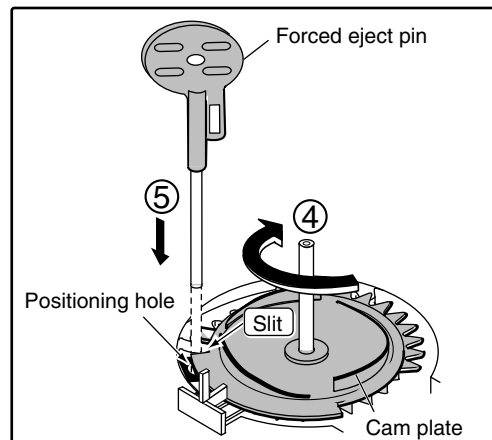

- ⑥ Mount the joint gear 3.
- ⑦ Mount the two joint gears 2.

Note: When mounting joint gears 2, engage the gears, being careful not to move joint gear 1.

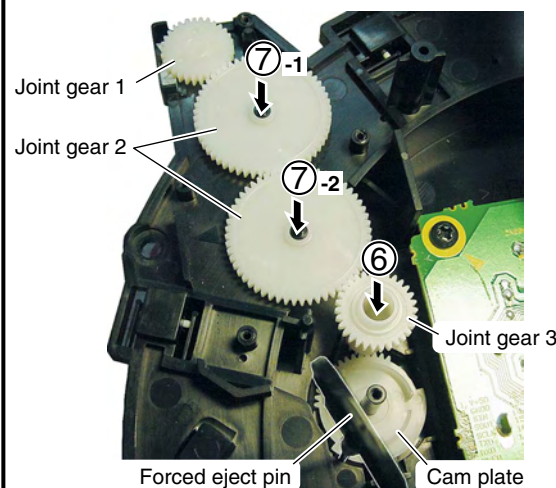

Notes on Replacement

⑧ Mount the gear plate.

⑨ Secure the gear plate, using the four screws.

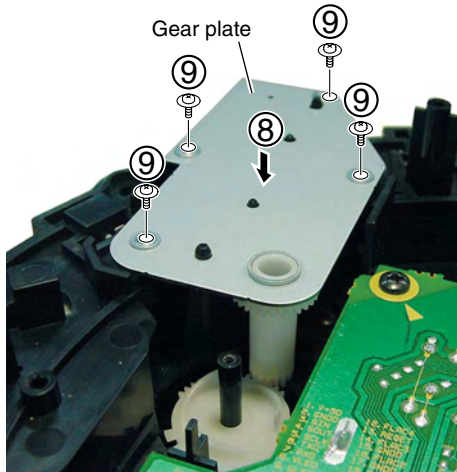

⑩ Remove the forced eject pin.

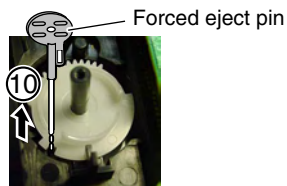

⑪ Mount the cam plate.

⑫ Install the gear spring 200.

⑬ Mount the adjust plate.

⑭ Secure the adjust plate, using one screw.

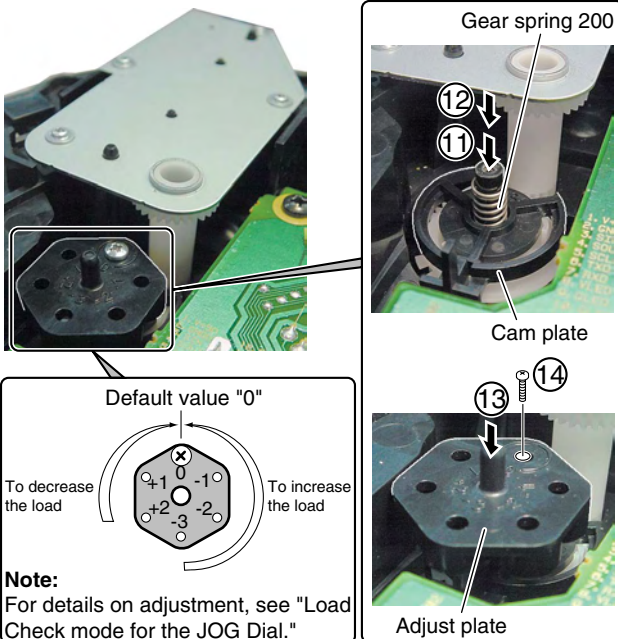

Note:
For details on adjustment, see "Load Check mode for the JOG Dial."

Notes on replacing the Sheet SW

● Place to adhere the Sheet SW

Notes:

1. Be careful not to warp the sheet SW.
2. Remove any dirt on the JOG holder to which the sheet SW is to be adhered. If some adhesive for the old sheet SW remains on the JOG holder, completely remove it with a cloth moistened with alcohol.
3. Do NOT place the sheet SW so that it is mounted on the rib of JOG holder 1000.
4. When adhering the sheet SW, be careful not to trap air bubbles in it. If air bubbles are formed, remove the sheet SW and adhere a new sheet SW.
Do NOT reuse the removed sheet SW.
5. When making a connection, be sure to first release the lock of the connector then securely relock the connector after making the connection.

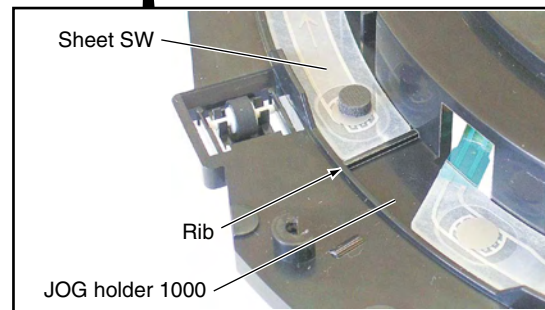
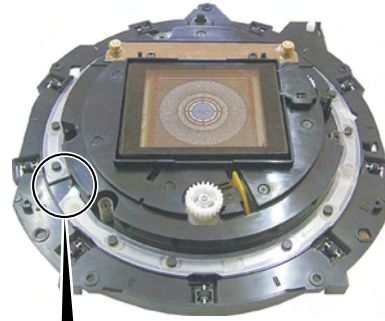

● Place to adhere the SW cushions HH48/2

Adhere the cushions to the right and left of the engraved arrows (←) (12 positions in total) on the sheet SW.

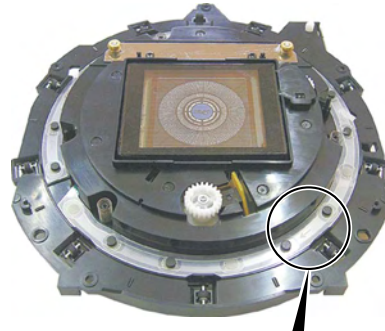

7.2 PARTS

7.2.1 IC

• The information shown in the list is basic information and may not correspond exactly to that shown in the schematic diagrams.

• List of IC

HD6417709SF133B-D, XC3S50-4TQG144C, MN103S71F, PEG237B-K

■ HD6417709SF133B-D (MAIN ASSY : IC101)

• CPU

• Pin Function

No.	Pin Name	Signal Name	I/O	Pin Function
1	MD1	SHMD1	I	Clock mode setting (pullup with 3.3V)
2	MD2	SHMD2	I	Clock mode setting (pullup with 3.3V)
3	Vcc-RTC	V+1R8	-	Power supply for RTC
4	XTAL2	N.C.	-	Not used
5	EXTAL2	-	-	Not used (connect to 1.8V power)
6	Vss-RTC	GND	-	Ground for RTC
7	NMI	-	-	Not used
8	IREQ0	TI BSREQ	I	TI DSP Input data request (↓ edge)
9	IREQ1	TI PCMQREQ	I	TI DSP Output data request (↓ edge)
10	IREQ2	-	-	Not used
11	IREQ3	-	-	Not used
12	IREQ4	DIS_XCS	I	Receiving completion interrupt of FL microcomputer data (↑ edge)
13	D31	D31	-	For debugging
14	D30	D30	-	For debugging
15	D29	D29	-	For debugging
16	D28	D28	-	For debugging
17	D27	D27	-	For debugging
18	D26	D26	-	For debugging
19	VssQ	GND	-	Ground
20	D25	D25	-	For debugging
21	VccQ	V+3R3	-	Power supply for I/O (3.3V)
22	D24	D24	-	For debugging
23	D23	D23	-	For debugging
24	D22	D22	-	For debugging
25	D21	D21	-	For debugging
26	D20	D20	-	For debugging
27	Vss	GND	-	Ground
28	D19	D19	-	For debugging
29	Vcc	V+1R8	-	Power supply for core (1.8V)
30	D18	D18	-	Connect with the servo DSP (Not used, pull down)
31	D17	D17	-	Connect with the servo DSP (Not used, pull down)
32	D16	D16	-	Connect with the servo DSP (Not used, pull down)
33	VssQ	GND	-	Ground
34	D15	D15	I/O	Data bus
35	VccQ	V+3R3	-	Power supply for I/O (3.3V)
36	D14	D14	I/O	Data bus
37	D13	D13	I/O	Data bus
38	D12	D12	I/O	Data bus
39	D11	D11	I/O	Data bus
40	D10	D10	I/O	Data bus
41	D9	D9	I/O	Data bus
42	D8	D8	I/O	Data bus
43	D7	D7	I/O	Data bus
44	D6	D6	I/O	Data bus
45	VssQ	GND	-	Ground

A

No.	Pin Name	Signal Name	I/O	Pin Function
46	D5	D5	I/O	Data bus
47	VccQ	V+3R3	–	Power supply for I/O (3.3V)
48	D4	D4	I/O	Data bus
49	D3	D3	I/O	Data bus
50	D2	D2	I/O	Data bus
51	D1	D1	I/O	Data bus
52	D0	D0	I/O	Data bus
53	A0	A0	O	Address bus
54	A1	A1	O	Address bus
55	A2	A2	O	Address bus
56	A3	A3	O	Address bus
57	VssQ	GND	–	Ground
58	A4	A4	O	Address bus
59	VccQ	V+3R3	–	Power supply for I/O (3.3V)
60	A5	A5	O	Address bus
61	A6	A6	O	Address bus
62	A7	A7	O	Address bus
63	A8	A8	O	Address bus
64	A9	A9	O	Address bus
65	A10	A10	O	Address bus
66	A11	A11	O	Address bus
67	A12	A12	O	Address bus
68	A13	A13	O	Address bus
69	VssQ	GND	–	Ground
70	A14	A14	O	Address bus
71	VccQ	V+3R3	–	Power supply for I/O (3.3V)
72	A15	A15	O	Address bus
73	A16	A16	O	Address bus
74	A17	A17	O	Address bus
75	A18	A18	O	Address bus
76	A19	A19	O	Address bus
77	A20	A20	O	Address bus
78	A21	A21	O	Address bus
79	Vss	GND	–	Ground
80	A22	N.C.	–	Not used
81	Vcc	V+1R8	–	Power supply for core (1.8V)
82	A23	N.C.	–	Not used
83	VssQ	GND	–	Ground
84	A24	N.C.	–	Not used
85	VccQ	V+3R3	–	Power supply for I/O (3.3V)
86	A25	N.C.	–	Not used
87	BS	XBS	O	Bus cycle start signal
88	RD	XRD	O	Read strobe
89	WE0	XWE0	O	Write strobe
90	WE1	XWE1	O	Write strobe
91	WE2	N.C.	–	Not used
92	WE3	N.C.	–	Not used
93	RD/WR	RDWR	O	Read/write
94	AUDSYNC	XAUSYC	–	For development
95	VssQ	GND	–	Ground

F

No.	Pin Name	Signal Name	I/O	Pin Function
96	CS0	XCS0	O	Area 0 chip select
97	VccQ	V+3R3	–	Power supply for I/O (3.3V)
98	CS2	XCS2	O	Area 2 chip select
99	CS3	XCS3	O	Area 3 chip select
100	CS4	XCS4	O	Area 4 chip select
101	CS5	XCS5	O	Area 5 chip select
102	CS6	XCS6	O	Area 6 chip select
103	CE2A	N.C.	–	Not used
104	CE2B	N.C.	–	Not used
105	CKE	CKE	O	CK enable (SDRAM)
106	RAS3L	XRAS3L	O	RAS3L (SDRAM)
107	RAS2L	N.C.	–	Not used
108	CASLL	XCASLL	O	CASL (SDRAM)
109	VssQ	GND	–	GND
110	CASLH	MOT_RST	O	Reset output of Motorola DSP (reset with H)
111	VccQ	V+3R3	–	Power supply for I/O (3.3V)
112	CASHL	TI_RST	O	Reset output for TI DSP (reset with H)
113	CASHH	N.C.	–	Not used
114	DACK0	XDACK0	–	Not used (connect to FPGA)
115	DACK1	XDACK1	–	Not used (connect to FPGA)
116	CAS2L	N.C.	–	Not used
117	CAS2H	N.C.	–	Not used
118	RAS3U	DAXLAT	O	DAC latch signal
119	RAS2U	MUTE	O	Audio output stage mute (H: Mute on)
120	TDO	TDO	–	For development
121	BACK	N.C.	–	Not used
122	BREQ	–	I	Bus request (Not used, pullup with 3.3V)
123	WAIT	XWAIT	I	Hardware wait request (FPGA)
124	RESETM	–	I	Manual reset (Not used, pullup with 3.3V)
125	PTH	FPGA_DONE	I	DONE signal for FPGA configuration
126	IOIS	RY/XBY	I	Connect to flash ROM
127	ASEMD0	ASEMD0	–	For development
128	ASEBRKAK	XASKAK	–	For development
129	PTG	FPGA_XINIT	I	INIT signal for FPGA configuration
130	AUDATA3	AUDATA3	–	For development
131	AUDATA2	AUDATA2	–	For development
132	Vss	GND	–	GND
133	AUDATA1	AUDATA1	–	For development
134	Vcc	V+1R8	–	Power supply for core (1.8V)
135	AUDATA0	AUDATA0	–	For development
136	TRST	XTRST	–	For development
137	TMS	TMS	–	For development
138	TDI	TDI	–	For development
139	TCK	TCK	–	For development
140	PINT11	–	–	Not used
141	PINT10	–	–	Not used
142	PINT9	UPDATE	–	For development
143	PINT8	MOT_EMPTY	I	Motorola FIFO empty signal input (High with EMPTY)
144	MDO	SHMD0	I	Clock mode setting (pull up with 3.3V)
145	Vcc-PLL1	V+1R8	–	Power supply for PLL1

A

No.	Pin Name	Signal Name	I/O	Pin Function
146	CAP1	–	–	External capacitor pin for PLL1
147	Vss-PLL1	GND	–	Ground for PLL1
148	Vss-PLL2	GND	–	Ground for PLL2
149	CAP2	N.C.	–	External capacitor pin for PLL2 (Not used)
150	Vcc-PLL2	V+1R8	–	Power supply for PLL2
151	AUDCK	AUDCK	–	For development
152	Vss	GND	–	Ground
153	Vss	GND	–	Ground
154	Vcc	V+1R8	–	Power supply for core (1.8V)
155	XTAL	N.C.	–	Not used
156	EXTAL	GND	–	Connect to ground
157	STATUS0	TI PCMAACK	O	TI DSP output data acknowledge
158	STATUS1	TI BSACK	O	TI DSP input data acknowledge
159	TCLK	FPGA_XPRG	O	PRG signal for FPGA configuration
160	IREQOUT	N.C.	–	Not used
161	VssQ	GND	–	Ground
162	CKIO	SH_66M	I	Clock input (65.975MHz)
163	VccQ	V+3R3	–	Power supply for I/O (3.3V)
164	TxD0	CONFDAT/DASSO	O	FPGA configuration/serial data output for DAC
165	SCKO	CONFIG_CLK/DASCK	O	FPGA configuration/serial clock output for DAC
166	TxD1	N.C.	–	Not used
167	SCK1	N.C.	–	Not used
168	TxD2	TXD2	O	TXD signal for production
169	SCK2	N.C.	–	Not used
170	RTS2	N.C.	–	Not used
171	RxD0	–	–	Not used
172	RxD1	–	–	Not used
173	Vss	GND	–	Ground
174	RxD2	RxD2	I	RXD signal for production
175	Vcc	V+1R8	–	Power supply for core (1.8V)
176	CTS2	CTS2	I	Not used
177	MCS7	CONT0	O	Control signal output
178	MCS6	DMA RST	O	FPGA reset output (reset with H)
179	MCS5	CONT1	I	Control signal input
180	MCS4	CONT2	I	Control signal input
181	VssQ	GND	–	Ground
182	WACKUP	CARD RST	O	TE4300 reset output (reset with H)
183	VccQ	V+3R3	–	Power supply for I/O (3.3V)
184	RESETOUT	GSL RST	O	ATA reset output (reset with H)
185	MCS3	MCS3	–	Not used
186	MCS2	CARD XINT	I	TE4300 interrupt input
187	MCS1	ATAIRQ	I	FPGA interrupt input
188	MCS0	MCS0	–	Not used
189	DRAK0	N.C.	–	Not used
190	DRAK1	N.C.	–	Not used
191	DREQ0	XDREQ0	I	DMA request 0 (FPGA)
192	DREQ1	XDREQ1	–	Not used (connect to FPGA)
193	RESETTP	RSTCPU	I	Reset input
194	CA	CA	I	Chip active (pull up with 3.3V)
195	MD3	SHMD3	I	Clock mode setting (pull down)

F

A

No.	Pin Name	Signal Name	I/O	Pin Function
196	MD4	SHMD4	I	Clock mode setting (pull up with 3.3V)
197	MD5	SHMD5	I	Clock mode setting (pull down)
198	AVss	GND	-	Ground
199	AN0	-	-	Not used
200	AN1	-	-	Not used
201	AN2	-	-	Not used
202	AN3	-	-	Not used
203	AN4	-	-	Not used
204	AN5	-	-	Not used
205	AVcc	V+3R3	-	Analog power supply (3.3V)
206	AN6	-	-	Not used
207	AN7	-	-	Not used
208	AVss	GND	-	Ground

B

C

D

E

F

A

■ XC3S50-4TQG144C (MAIN ASSY : IC301)

- FPGA (Field Programmable Gate Array)

● Pin Function

No.	Pin Name	Signal Name	I/O	Pin Function
1	I/O DCI	N.C.	–	Not used
2	I/O DCI	TI_XCS	O	DSP (IC401) chip select signal
3	VCCO	V+3R3	–	Power supply for I/O
4	IO/VREF	TI_XHDS1	O	DSP (IC401) data strobe signal
5	I/O	DMA_XRST	I	FPGA reset input
6	I/O	ATADREQ	I	ATADMA request signal
7	I/O	ATAWR	O	ATA write signal
8	I/O	ATARD	O	ATA read signal
9	GND	GND	–	Ground
10	I/O	ATARDY	I	ATA ready signal
11	I/O	ATADACK	O	ATADMA acknowledge signal
12	I/O	ATAA1	O	ATA address bus
13	I/O	ATAA0	O	ATA address bus
14	I/O	ATAA2	O	ATA address bus
15	I/O	ATACS0	O	ATA chip select 0
16	GND	GND	–	Ground
17	I/O	ATACS1	O	ATA chip select 1
18	IO/VREF	ATA15	I/O	ATA data bus
19	VCCO	V+3R3	–	Power supply for I/O
20	IO/VREF	ATA0	I/O	ATA data bus
21	I/O	ATA14	I/O	ATA data bus
22	GND	GND	–	Ground
23	I/O	ATA1	I/O	ATA data bus
24	IO/VREF	ATA13	I/O	ATA data bus
25	I/O	ATA2	I/O	ATA data bus
26	I/O	ATA12	I/O	ATA data bus
27	I/O	ATA3	I/O	ATA data bus
28	I/O	ATA11	I/O	ATA data bus
29	GND	GND	–	Ground
30	I/O	ATA4	I/O	ATA data bus
31	I/O	ATA10	I/O	ATA data bus
32	I/O	ATA5	I/O	ATA data bus
33	I/O	ATA9	I/O	ATA data bus
34	VCCO	V+3R3	–	Power supply for I/O
35	I/O DCI	ATA6	I/O	ATA data bus
36	I/O DCI	ATA8	I/O	ATA data bus
37	M1	V+2R5FPGA	I	Configuration mode setting (connect to 2.5V)
38	M0	V+2R5FPGA	I	Configuration mode setting (connect to 2.5V)
39	M2	V+2R5FPGA	I	Configuration mode setting (connect to 2.5V)
40	I/O DUAL	ATA7	I/O	ATA data bus
41	I/O DUAL	DIS_DIN	O	FL microcomputer (IC1002) data output
42	GND	GND	–	Ground
43	VCCO	V+3R3	–	Power supply for I/O
44	IO/VREF	DIS_XCS	I	FL microcomputer (IC1002) chip select input

F

No.	Pin Name	Signal Name	I/O	Pin Function
45	GND	GND	–	Ground
46	I/O DUAL	DIS_DOUT	I	FL microcomputer (IC1002) data input
47	I/O DUAL	DIS_SCLK	I	FL microcomputer (IC1002) clock input
48	VCCAUX	V+2R5FPGA	–	Auxiliary power
49	VCCINT	V+1R2FPGA	–	Internal core power supply
50	I/O DUAL	SUB_CODE	I	Subcode input
51	I/O DUAL	M_DATR2	O	DSP (IC402) audio data R2 output
52	IO/GCLK2	M_DATR1	O	DSP (IC402) audio data R1 output
53	IO/GCLK3	M_DATL2	O	DSP (IC402) audio data L2 output
54	VCCO	V+3R3	–	Power supply for I/O
55	IO/GCLK0	M_DATL1	O	DSP (IC402) audio data L1 output
56	IO/GCLK1	FPGA_66M	I	System clock input
57	IO/DOUT/BUSY	N.C.	–	Not used
58	IO/INIT	FPGA_XINIT	I/O	INIT signal for FPGA configuration
59	I/O DUAL	M_DBCLK	O	DSP (IC402) audio data clock output
60	I/O DUAL	M_BCLK	O	DSP (IC402) audio data clock output
61	VCCINT	V+1R2FPGA	–	Internal core power supply
62	VCCAUX	V+2R5FPGA	–	Auxiliary power
63	I/O DUAL	M_REQ	I	DSP (IC402) request signal
64	GND	GND	–	Ground
65	IO/DIN/D0	CONFDAT	I	Data input for FPGA configuration
66	VCCO	V+3R3	–	Power supply for I/O
67	GND	GND	–	Ground
68	I/O DCI	M_XWE	O	DSP (IC402) write signal
69	I/O DCI	M_XRD	O	DSP (IC402) read signal
70	IO/VREF	M_XCS	O	DSP (IC402) chip select signal
71	DONE	FPGA_DONE	O	DONE signal for FPGA configuration
72	CCLK	CONFIG_CLK	I	Clock input for FPGA configuration
73	I/O DCI	M_VALID	O	DSP (IC402) audio data valid signal
74	I/O DCI	XWE0	I	CPU write signal
75	VCCO	V+3R3	–	Power supply for I/O
76	I/O	RDWR	I	CPU read/write signal
77	I/O	XRD	I/O	CPU data bus
78	I/O	D0	I/O	CPU data bus
79	I/O	D1	I/O	CPU data bus
80	I/O	D2	I/O	CPU data bus
81	GND	GND	–	Ground
82	I/O	D3	I/O	CPU data bus
83	I/O	D4	I/O	CPU data bus
84	IO/VREF	D5	I/O	CPU data bus
85	I/O	D6	I/O	CPU data bus
86	I/O	D7	I/O	CPU data bus
87	I/O	XWE1	I	CPU write signal
88	GND	GND	–	Ground
89	I/O	D8	I/O	CPU data bus
90	IO/VREF	D9	I/O	CPU data bus
91	VCCO	V+3R3	–	Power supply for I/O
92	IO/VREF	D10	I/O	CPU data bus
93	I/O	D11	I/O	CPU data bus
94	GND	GND	–	Ground

A

No.	Pin Name	Signal Name	I/O	Pin Function
95	I/O	D12	I/O	CPU data bus
96	I/O	D13	I/O	CPU data bus
97	I/O	D14	I/O	CPU data bus
98	IO/VREF	D15	I/O	CPU data bus
99	I/O	A1	I	CPU address bus
100	I/O	A2	I	CPU address bus
101	GND	GND	–	Ground
102	I/O	A3	I	CPU address bus
103	I/O	A4	I	CPU address bus
104	I/O	A5	I	CPU address bus
105	I/O	A6	I	CPU address bus
106	VCCO	V+3R3	–	Power supply for I/O
107	I/O DCI	A7	I	CPU address bus
108	I/O DCI	A8	I	CPU address bus
109	TDO	N.C.	–	Not used
110	TCK	N.C.	–	Not used
111	TMS	N.C.	–	Not used
112	I/O	A11	I	CPU address bus
113	I/O	A10	I	CPU address bus
114	GND	GND	–	Ground
115	VCCO	V+3R3	–	Power supply for I/O
116	I/O	A9	I	CPU address bus
117	GND	GND	–	Ground
118	I/O	N.C.	–	Not used
119	I/O	CARD_XRD	O	TE4300 (IC403) read signal
120	VCCAUX	V+2R5FPGA	–	Auxiliary power
121	VCCINT	V+1R2FPGA	–	Internal core power supply
122	I/O	CARD_XCS	O	TE4300 (IC403) chip select signal
123	IO/VREF	CARD_XWR	O	TE4300 (IC403) write signal
124	IO/GCLK4	XBS	I	CPU bus cycle signal
125	IO/GCLK5	N.C.	–	Not used
126	VCCO	V+3R3	–	Power supply for I/O
127	IO/GCLK6	XCS2	I	CPU area 2 chip select signal
128	IO/GCLK7	XCS4	I	CPU area 4 chip select signal
129	IO/VREF	XCS5	I	CPU area 5 chip select signal
130	I/O	XCS6	I	CPU area 6 chip select signal
131	I/O	XDACK0	–	Not used (connect to CPU)
132	I/O	XDACK1	–	Not used (connect to CPU)
133	VCCINT	V+1R2FPGA	–	Internal core power supply
134	VCCAUX	V+2R5FPGA	–	Auxiliary power
135	I/O	XWAIT	O	CPU wait signal
136	GND	GND	–	Ground
137	I/O	XDREQ0	O	CPUDMA request output 0
138	VCCO	V+3R3	–	Power supply for I/O
139	GND	GND	–	Ground
140	I/O DCI	XDREQ1	–	Not used (connect to CPU)
141	I/O DCI	TI_HRDY	I	DSP (IC401) data ready signal
142	HSWAP_EN	V+2R5FPGA	I	Bus state setting in configuration (pull down)
143	PROG_B	FPGA_XPRG	I	PRG signal for FPGA configuration
144	TDI	N.C.	I	Not used

F

■ MN103S71F (MAIN ASSY : IC603)

• SODC

● Pin Function

No.	Mark	Pin Name	I/O	Pin Function
1	P2	XDMUTE1	O	Mute control of driver IC
2	P3	XDMUTE2	O	Mute control of driver IC
3	P4/EXCNT0	ILMUSK	I	Connect to VSS
4	VDD3	VDD3	–	Power supply (VD3V)
5	VSS	VSS	–	GNDD
6	P5/EXCNT1	INSIDE	I	Servo mecha inside SW input (L: ON)
7	P6/NSPCCS	SPGAIN	O	SPDL motor current switching control (at inversion brakes: H)
8	P7/FADR17	FADR17/NSPCCS	O	Address output to FLASH ROM
9	P8/FADR18	FADR18	O	NC
10	FADR11	FADR11	O	Address output to FLASH ROM
11	FADR9	FADR9	O	Address output to FLASH ROM
12	VDD15	VDD15	–	Power supply (VD1R5)
13	FADR8	FADR8	O	Address output to FLASH ROM
14	FADR13	FADR13	O	Address output to FLASH ROM
15	FADR14	FADR14	O	Address output to FLASH ROM
16	NWE	NWE	O	Write enable output to FLASH ROM
17	FADR16	FADR16	O	Address output to FLASH ROM
18	FADR15	FADR15	O	Address output to FLASH ROM
19	DRAMVDD15	DRAMVDD15	–	DRAM power supply (DRAMD1R5)
20	DRAMVSS	DRAMVSS	–	GND for DRAM
21	VSS	VSS	–	GNDD
22	FADR12	FADR12	O	Address output to FLASH ROM
23	FADR7	FADR7	O	Address output to FLASH ROM
24	FADR6	FADR6	O	Address output to FLASH ROM
25	FADR5	FADR5	O	Address output to FLASH ROM
26	FADR4	FADR4	O	Address output to FLASH ROM
27	FADR3	FADR3	O	Address output to FLASH ROM
28	FADR2	FADR2	O	Address output to FLASH ROM
29	FADR1	FADR1	O	Address output to FLASH ROM
30	FADR0	FADR0	O	Address output to FLASH ROM
31	VSS	VSS	–	GNDD
32	VDD3	VDD3	–	Power supply (VD3V)
33	FDT0	FDT0	I/O	Data input/output to FLASH ROM
34	FDT1	FDT1	I/O	Data input/output to FLASH ROM
35	FDT2	FDT2	I/O	Data input/output to FLASH ROM
36	FDT3	FDT3	I/O	Data input/output to FLASH ROM
37	FDT4	FDT4	I/O	Data input/output to FLASH ROM
38	FDT5	FDT5	I/O	Data input/output to FLASH ROM
39	FDT6	FDT6	I/O	Data input/output to FLASH ROM
40	FDT7	FDT7	I/O	Data input/output to FLASH ROM
41	NCE	NCE	O	Chip enable output to FLASH ROM
42	FADR10	FADR10	O	Address output to FLASH ROM
43	NOE	NOE	O	Output enable output to FLASH ROM
44	MMOD	MMOD	I	Connect to VSS

A

No.	Mark	Pin Name	I/O	Pin Function
45	NRST	NRST	I	Hardware reset input
46	VSS	VSS	–	GNDD
47	SCLOCK	SCLOCK	I/O	NC
48	SDATA	SDATA	I/O	NC
49	TxD/EXTRG0/MDATA	TXD	I/O	NC
50	RxD/EXTRG1/MCLOCK	RXD	I/O	NC
51	VDD3	VDD3	–	Power supply (VD3V)
52	OSCI	OSCI	I	Oscillation input
53	OSCO	OSCO	O	Oscillation output (16.93MHz)
54	VSS	VSS	–	GNDD
55	DRV0	DRV0(VRCAP)	O	NC
56	DRV1	DRV1(SPDRV)	O	Spindle motor control
57	DRV2	DRV2(FBAL)	O	Focus balance control
58	DRV3	DRV3(TBAL)	O	NC
59	DRV4	DRV4(STPM1P)	O	Stepping motor control
60	DRV5	DRV5(STPM1N)	O	Stepping motor control
61	DRV6	DRV6(6VRSW)	O	NC
62	DRV7	DRV7(7VRSW)	O	NC
63	VSS	VSS	–	GNDD
64	DRV8	DRV8(FCSG)	O	NC
65	DRV9	DRV9(NFEPRST)	O	NC
66	DRV10	DRV10	O	NC
67	DRV11	DRV11(LOAD)	O	Loading motor control
68	DRV12	DRV12(FEPCK)	O	Clock output to FEP
69	DRV13	DRV13(FEPDT)	I/O	Data input/output to FEP
70	DRV14	DRV14(FEPEN)	O	Enable output to FEP
71	DRAMVSS	DRAMVSS	–	GND for DRAM
72	DRAMVDD15	DRAMVDD15	–	DRAM power supply (DRAMD1R5)
73	DRAMVDD33	DRAMVDD33	–	Power supply (VD3V)
74	VDD3	VDD3	–	Power supply (VD3V)
75	FG	FG	I	Spindle motor FG input
76	TX	TX	O	NC
77	VDD15	VDD15	–	Power supply (VD1R5)
78	VSS	VSS	–	GNDD
79	TSTSG	TSTSG	O	EQ calibration signal to FEP
80	VFOSHORT	VFOSHORT	O	VFO short control
81	JLINE	JLINE	O	NC
82	BDO	BDO	I	BDO (Black Dog Out) input
83	OFTR	OFTR	I	OFTR (Off Track) input
84	AVSSD	AVSSD	–	GNDA
85	ROUT	ROUT	O	NC
86	LOUT	LOUT	O	NC
87	AVDDD	AVDDD	–	Power supply (VA3V)
88	VCOF	VCOF	I	VCO control voltage
89	TRCRS	TRCRS	I	Input for TRCRS (Track Cross) generation
90	AVDDC	AVDDC	–	Power supply (VA3V)
91	WBLIN	WBLIN	I	Connect to VSS
92	CSLFLT	CSLFLT	I	NC
93	RFDIF	RFDIF	I	NC
94	AVSSC	AVSSC	–	GNDA

F

No.	Mark	Pin Name	I/O	Pin Function
95	PLFLT2	PLFLT2	I	Connect a capacitor for PLL
96	PLFLT1	PLFLT1	I	Connect a capacitor for PLL
97	AVSSB	AVSSB	-	GNDA
98	ARF	ARF	I	RF+ input
99	NARF	NARF	I	RF- input
100	VHALF	VHALF	I	Reference voltage (1.65V) input
101	RVI	RVI	I	VREFH reference current control
102	VREFH	VREFH	I	Reference voltage (2.2V) input
103	DSL2	DSL2	I	Connect a capacitor for DSL (Data SLicer)
104	DSL1	DSL1	I	Connect a capacitor for DSL (Data SLicer)
105	AVDDB	AVDDB	-	Power supply (VA3V)
106	JITOUT	JITOUT	O	Jitter monitor output
107	AVDDA	AVDDA	-	Power supply (VA3V)
108	TECAPA	TECAPA	I	NC
109	AD0	AD0(FE)	I	Focus error input
110	AD2	AD2(AS)	I	RFAS input
111	AD1	AD(TE)	I	Tracking error input
112	AD3	AD3(RFENV)	I	RF envelope input
113	AD4	AD4(RFDIF)	I	Radial differential input
114	AD5	AD5(FEDRV)	I	Focus drive input
115	AD6	AD6(TEDRV)	I	Tracking drive input
116	AD7	AD7(T+)	I	Connect to VSS
117	AD8	AD8(T-)	I	Connect to VSS
118	AVSSA	AVSSA	-	GNDA
119	PWM0	PWM0	O	Focus drive control
120	PWM1	PWM1	O	Tracking drive control
121	VSS	VSS	-	GNDD
122	VDD3	VDD3	-	Power supply (VD3V)
123	IDGT	IDGT	O	NC
124	DTR	DTR	O	NC
125	MONI0/P9	BUSY/MONI0	I/O	Monitor output
126	MONI1/P10	NAMUTE/MONI1	I/O	Monitor output
127	MONI2/P11	NDMUTE1/MONI2	I/O	Monitor output
128	MONI3/P12	NDMUTE2/MONI3	I/O	Monitor output
129	MSTPOL/MONI4	MSTPOL/MONI4	I	
130	DASPST/MONI5	DASPST/MONI5	I	Connect to VSS
131	NEJECT/MONI6	NEJECT/MONI6	O	NC
132	NTRYCL/MONI7	NTRYCL/MONI7	O	NC
133	DMARQ	DMARQ	O	DMA request output to the host
134	NIOWR	NIOWR	I	Host write input
135	VDD3	VDD3	-	Power supply (VD3V)
136	VSS	VSS	-	GNDD
137	NIORD	NIORD	I	Host read input
138	IODRY	IODRY	O	Ready output to the host
139	NDMACK	NDMACK	I	Host DMA acknowledge input
140	INTRQ	INTRQ	O	Interrupt output to the host
141	NIOCS16	NIOCS16	O	Data bus width select
142	DA1	DA1	I	Assress input
143	NPDIAG	NPDIAG	I/O	
144	DA0	DA0	I	Assress input

A

No.	Mark	Pin Name	I/O	Pin Function
145	VSS	VSS	–	GNDD
146	VDD3	VDD3	–	Power supply (VD3V)
147	DA2	DA2	I	Address input
148	NCS1FX	NCS1FX	I	Chip select input
149	NCS3FX	NCS3FX	I	Chip select input
150	NDASP	NDASP	I/O	
151	HDD15	HDD15	I/O	Data input/output
152	HDD0	HDD0	I/O	Data input/output
153	HDD14	HDD14	I/O	Data input/output
154	HDD1	HDD1	I/O	Data input/output
155	HDD13	HDD13	I/O	Data input/output
156	VDD3	VDD3	–	Power supply (VD3V)
157	VDD15	VDD15	–	Power supply (VD1R5)
158	VSS	VSS	–	GNDD
159	HDD2	HDD2	I/O	Data input/output
160	HDD12	HDD12	I/O	Data input/output
161	HDD3	HDD3	I/O	Data input/output
162	HDD11	HDD11	I/O	Data input/output
163	HDD4	HDD4	I/O	Data input/output
164	HDD10	HDD10	I/O	Data input/output
165	HDD5	HDD5	I/O	Data input/output
166	VSS	VSS	–	GNDD
167	VDD3	VDD3	–	Power supply (VD3V)
168	HDD9	HDD9	I/O	Data input/output
169	HDD6	HDD6	I/O	Data input/output
170	HDD8	HDD8	I/O	Data input/output
171	HDD7	HDD7	I/O	Data input/output
172	VDDH	VDDH	–	Power supply (VD5V)
173	NRESET	NRESET	I	Reset input from the host
174	MASTER	MASTER	I	Connect to VSS
175	P0/SERIAL	LPS1	I	Loading mecha SW input
176	P1/SERIAL	LPS2	I	Loading mecha SW input

E

F

■ PEG237B-K (MFLB ASSY : IC1002)

• FL Microcomputer

● Pin Function

No.	Pin Name	Signal Name	I/O	Pin Function
1	P96/ANEX1	T/B	I	VINYL SPEED ADJUST input Clockwise direction: Vcc side
2	P95/ANEX0	R/S	I	VINYL SPEED ADJUST input Clockwise direction: Vcc side
3	P94	MODEL1	I	Model setting 1 (pull up with 5V) Distinguish between CDJ-800MK2 and CDJ-1000MK3.
4	P93/DA0	MODEL2	I	Model setting 2 (pull up with 5V) Distinguish between CDJ-800MK2 and CDJ-1000MK3.
5	P92/TB2IN	N.C.	-	Not used
6	P91/TB1IN	JOG1	I	Pulse period measurement processing (connect to JOG1)
7	P90/TB0IN	N.C.	-	Not used
8	BYTE	-	-	Not used (Connect to GND)
9	CNVss	CNVSS	-	Not used (GND pull down)
10	P87/XCIN	-	-	Not used (Connect to GND)
11	P86/XCOUT	-	-	Not used (Connect to GND)
12	XRESET	XRESET	I	Reset input
13	Xout	XOUT	O	Oscillator (16MHz)
14	Vss	GNDD	-	GND
15	Xin	XIN	I	Oscillator (16MHz)
16	Vcc1	V+5D	-	Power supply
17	P85/XNMI	XNMI	I	Not used (pull up with 5V)
18	P84/XINT2	-	-	Not used (connect to 5V)
19	P83/XINT1	-	-	Not used (connect to 5V)
20	P82/XINT0	-	-	Not used (connect to 5V)
21	P81	-	-	Not used (connect to 5V)
22	P80	-	-	Not used (connect to 5V)
23	P77	-	-	Not used (connect to 5V)
24	P76	-	-	Not used (connect to 5V)
25	P75/TA2IN	JOG2	I	Two-phase pulse signal input When input signal of TA2OUT pin is period of "H", up count (clockwise) at rising edge of TA2IN pin, down count (counterclockwise) at falling edge.
26	P74/TA2OUT	JOG1	I	
27	P73/XCTS2/XRTS2/TA1IN	TCH	I	JOG touch sensor ON with L
28	P72/CLK2/TA1OUT	J_SCLK	O	Serial clock signal for JOG FL
29	P71/RxD2/SCL2/TA0IN	N.C.	-	Not used
30	P70/TXD2/SDA2/TA1OUT	J_SDO	O	Serial data signal for JOG FL
31	P67/TXD1/SDA1	FL_SDO	O	Serial data signal for data FL
32	P66/RxD1/SCL1	RXD	I	For development
33	P65/CLK1	FL_SCLK	O	Serial clock signal for data FL
34	P64/XCTS1/XRTS1/XCTS0/XCLKS1	F_BUSY	I	For development
35	P63/TXD0/SDA0	SDO	O	Data output of main communication
36	P62/RxD0/SCL0	SIN	I	Data input of main communication
37	P61/CLK0	SCLK	O	Clock output of main communication
38	P60/XCTS0/XRTS0	XCS	O	Chip select output of main communication
39	P57/CLKOUT	N.C.	-	Not used
40	P56	N.C.	-	Not used
41	P55	-	I	Not used (pull down)
42	P54	DFL_LAT	O	Latch signal for data FL
43	P53	DFL_BK	O	Blank signal for data FL
44	P52	J_LAT	O	Latch signal for JOG FL
45	P51	J_BK	O	Blank signal for JOG FL
46	P50	-	-	Not used (pull up with 5V)
47	P47	LED_24	O	LED (CARD_IND • yellow/green) Turn off the light with L.
48	P46	LED_23	O	LED (CDJ • yellow/green) Turn off the light with L.
49	P45	LED_22	O	LED (VINYL • blue) Turn off the light with L.
50	P44	LED_21	O	LED (TEMPO_RESET • yellow/green) Turn off the light with L.

A

No.	Pin Name	Signal Name	I/O	Pin Function
51	P43	LED_20	O	LED (MASTER_TEMPO • Red) Turn off the light with L.
52	P42	N.C.	–	Not used
53	P41	N.C.	–	Not used
54	P40	N.C.	–	Not used
55	P37	N.C.	–	Not used
56	P36	LED_15	O	LED (CUEC • Amber) Turn off the light with L.
57	P35	LED_14	O	LED (CUEC • Green) Turn off the light with L.
58	P34	LED_13	O	LED (CUEC • Red) Turn off the light with L.
59	P33	LED_12	O	LED (CUEB • Amber) Turn off the light with L.
60	P32	LED_11	O	LED (CUEB • Green) Turn off the light with L.
61	P31	LED_10	O	LED (CUEB • Red) Turn off the light with L.
62	Vcc2	+V5	–	Power supply
63	P30	LED_09	O	LED (CUEA • Amber) Turn off the light with L.
64	Vss	GNDD	–	GND
65	P27	LED_08	O	LED (CUEA • Green) Turn off the light with L.
66	P26	LED_07	O	LED (CUEA • Red) Turn off the light with L.
67	P25	LED_06	O	LED (DIRECTION_REV • Red) Turn off the light with L.
68	P24	LED_05	O	LED (RELOOP • Amber) Turn off the light with L.
69	P23	LED_04	O	LED (LOOP_OUT • Amber) Turn off the light with L.
70	P22	LED_03	O	LED (LOOP_IN • Amber) Turn off the light with L.
71	P21	LED_02	O	LED (CUE • Amber) Turn off the light with L.
72	P20	LED_01	O	LED (PLAY/PAUSE • Green) Turn off the light with L.
73	P17	ELOCK	I	EJECT LOCK SW
74	P16/XINT4	SW0	I	DIRECTION SW
75	P15/XINT3	–	–	Not used (Connect to GND)
76	P14	–	–	Not used (Connect to GND)
77	P13	–	–	Not used (Connect to GND)
78	P12	–	–	Not used (Connect to GND)
79	P11	–	–	Not used (Connect to GND)
80	P10	–	–	Not used (Connect to GND)
81	P07/AN0_7	CUEC	I	Key input (CUEC) L: ON
82	P06/AN0_6	CUEB	I	Key input (CUEB) L: ON
83	P05/AN0_5	CUEA	I	Key input (CUEA) L: ON
84	P04/AN0_4	RELP	I	Key input (RELOOP) L: ON
85	P03/AN0_3	LOOPOUT	I	Key input (LOOP_OUT) L: ON
86	P02/AN0_2	LOOPIN	I	Key input (LOOP_IN) L: ON
87	P01/AN0_1	CUE	I	Key input (CUE) L: ON
88	P00/AN0_0	PLAY	I	Key input (PLAY/PAUSE) L: ON
89	P107/AN7/XKI3	ADCT	I	Slider center value adjustment
90	P106/AN6/XKI2	ADIN	I	Tempo slider input + direction: Vcc side, – direction: GND side
91	P105/AN5/XKI1	KEY0	I	Key input 0 (AD input)
92	P104/AN4/XKI0	KEY1	I	Key input 1 (AD input)
93	P103/AN3	KEY2	I	Key input 2 (AD input)
94	P102/AN2	–	–	Not used (Connect to GND)
95	P101/AN1	–	–	Not used (Connect to GND)
96	AVSS	GNDD	–	GND
97	P100/AN0	–	–	Not used (Connect to GND)
98	VREF	V+5D	–	Reference voltage input of A/D converter
99	AVcc	V+5D	–	Reference voltage input of A/D converter
100	P97/XADTRG	–	–	Not used (Connect to GND)

8. PANEL FACILITIES

8.1 PANEL SECTION

Upper Panel

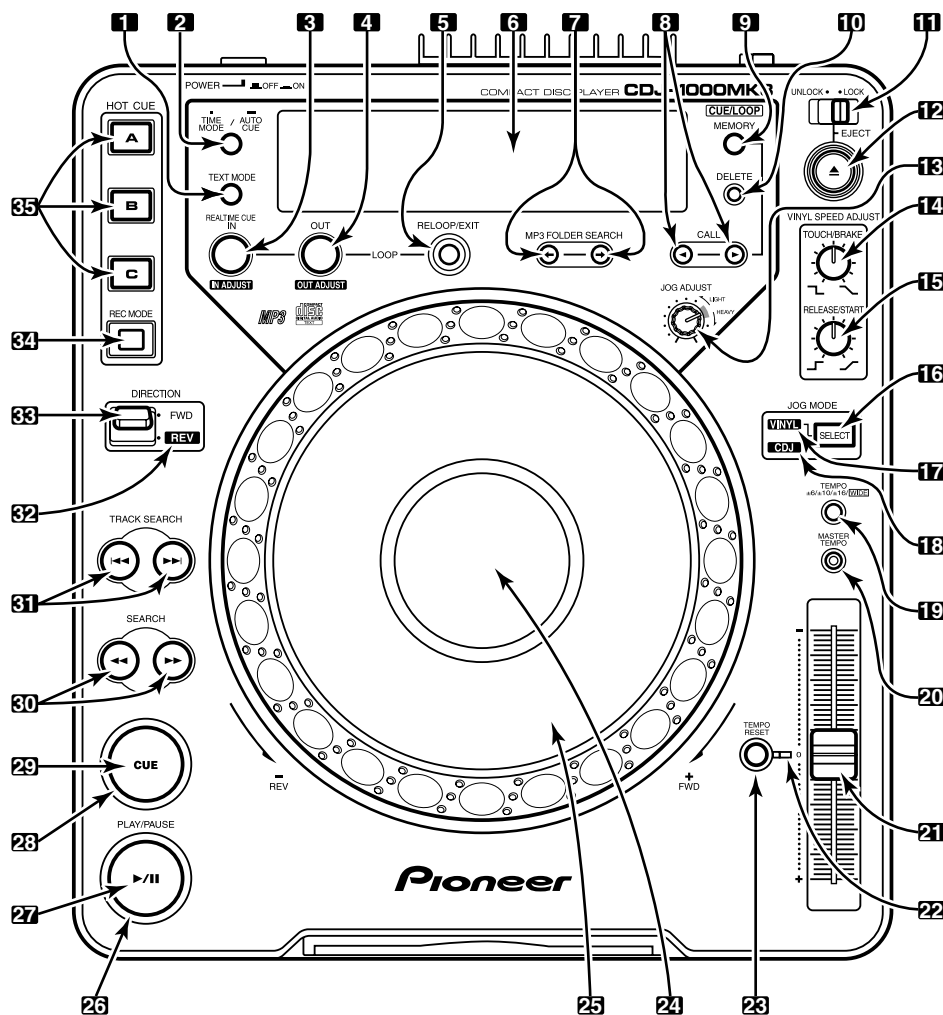

Rear Panel

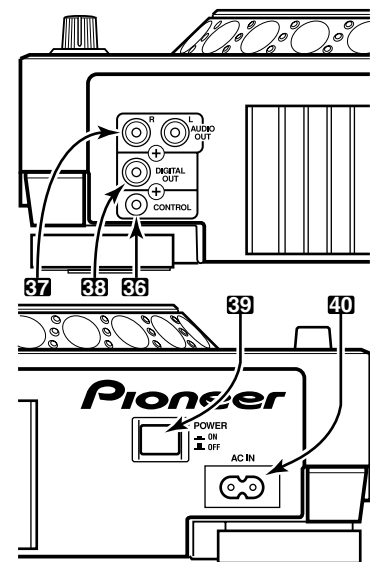

Front Panel

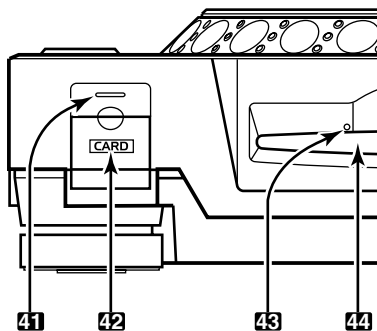

1. Display selector button (TEXT MODE)

Each time this button is pressed, the display alternates between WAVE and TEXT (track name/album name/artist name). When playing MP3, WAVE display may not be possible, depending on the track.

2. TIME MODE/AUTO CUE button

TIME MODE:

Each time the button is pressed, the display's time display alternates between the current elapsed play time and the remaining play time (REMAIN).

When playing MP3, the REMAIN time may not display immediately, depending on the track.

- The current TIME MODE setting is retained in memory even when the power is turned off.

AUTO CUE:

When the button is held depressed for 1 second or more, the AUTO CUE mode is alternately enabled and disabled.

When the button is held depressed for 5 seconds or more, the AUTO CUE level is toggled.

- The current AUTO CUE on/off and AUTO CUE level settings are retained in memory even when power is turned off.

3. LOOP IN/REALTIME CUE (IN ADJUST) button/indicator

Realtime cue

Loop-in point input

Loop-in point adjust

4. LOOP OUT (OUT ADJUST) button/indicator

Loop-out point input

Loop-out point adjust

5. RELOOP/EXIT button

6. Display

7. FOLDER SEARCH buttons (←, →)

During MP3 playback, layered CD-ROM folder search will be performed in the designated direction.

8. CUE/LOOP CALL buttons (◀, ▶)

Use to call cue points and loop points recorded in external memory (when memory card is loaded).

9. CUE/LOOP MEMORY button

Use to record cue points and loop points to external memory (when memory card is loaded).

10. CUE/LOOP DELETE button

Use to delete cue points and loop points from external memory (when memory card is loaded).

11. EJECT UNLOCK/LOCK switch

UNLOCK: Disc is ejected when button is pressed, even if pressed during play.

LOCK: Disc cannot be ejected if button is pressed during play. Set unit to pause mode and then press button to eject disc.

12. EJECT button (▲)

When button is pressed, disc rotation stops and disc is ejected from port.

If the **EJECT UNLOCK/LOCK** switch is set to the [LOCK] position, the disc will not be ejected unless the unit is set to the pause mode before pressing the **EJECT** button.

13. JOG ADJUST dial

Use to adjust the felt resistance (light/heavy) of the jog dial when it is rotated.

A 14. **VINYL SPEED ADJUST TOUCH/BRAKE dial**

When the **JOG MODE SELECT** button is set to [VINYL], this dial determines the deceleration speed until play stops when the surface of the jog dial is pressed or the **PLAY/PAUSE** button is pressed.

When the **VINYL SPEED ADJUST TOUCH/BRAKE** dial is rotated counterclockwise, play stops quickly; when the dial is rotated clockwise, play decelerates more slowly before coming to a stop.

15. VINYL SPEED ADJUST RELEASE/START dial

When the **JOG MODE SELECT** button is set to [VINYL], this dial determines the acceleration speed until full playback speed is reached when the jog dial is released or the **PLAY/PAUSE** button is pressed.

When the **VINYL SPEED ADJUST RELEASE/START** dial is rotated counterclockwise, play accelerates to full speed quickly; when the dial is rotated clockwise, play accelerates more slowly before reaching full speed.

16. JOG MODE SELECT button

VINYL mode: When the surface of the jog dial is pressed during playback, play stops, and if the jog dial is then rotated, sound is produced in accordance with the degree of rotation.

- The currently set jog mode is stored in memory even when power is turned off.

CDJ mode: The above action does not occur when the jog dial is pressed.

17. VINYL indicator

Lights when jog mode is set to VINYL mode.

18. CDJ indicator

Lights when jog mode is set to CDJ mode.

19. TEMPO control range selector button

(TEMPO $\pm 6/\pm 10/\pm 16$ /WIDE)

Each time this button is pressed, the tempo adjust slider's variable range alternates between $\pm 6\%$, $\pm 10\%$, $\pm 16\%$ and WIDE.

20. MASTER TEMPO button/indicator

When pressed, the master tempo function alternates ON/OFF.

21. Tempo adjust slider

When moved toward the user (+ front), the track tempo increases, and when moved away from the user (- rear), the tempo decreases.

22. Tempo reset indicator

Regardless of the position of the tempo adjust slider, this indicator lights when the tempo adjustment is at "0" (normal tempo).

23. TEMPO RESET button

Regardless of the position of the tempo adjust slider, pressing this button causes the tempo to be reset instantly to "0" (normal tempo). Pressing the button once again releases the reset.

24. Jog dial display**25. Jog dial (+FWD/-REV)****26. Play/pause indicator**

Lights during playback, and flashes during pause mode.

27. PLAY/PAUSE button (▶/⏸)**28. Cue indicator**

When a cue point has been set, lights except during search.

Flashes in the pause mode to show that a new cue point can be input.

29. CUE button

Cue point setting

Back cue

Cue point sampler

30. SEARCH buttons (◀◀, ▶▶)**31. TRACK SEARCH buttons (◀◀◀, ▶▶▶)****32. Reverse indicator (REV)**

Lights when **DIRECTION** selector switch is set to reverse [REV].

33. DIRECTION selector switch (FWD/REV)

When set to [REV] (near side), reverse play is enabled.

34. HOT CUE REC MODE button

Switches the function of the **HOT CUE** button (record/call)

- Defaults to call mode when power is first turned on.

35. HOT CUE button/indicator (A, B, C)

When the indicators A, B, C light red, the hot cue point recording mode is enabled for that point. When any of the indicators A, B, C light green (HOT CUE point) or orange (HOT LOOP point), the respective call-up mode is enabled, and if the corresponding button is pressed, playback starts from the set hot cue (loop) point. When an indicator is not lighted, no hot cue (loop) point has been recorded.

Rear Panel**36. CONTROL connector**

When the accessory control cord is used to connect this connector to the corresponding CONTROL connector on a Pioneer DJ mixer, the DJ mixer can be used to control the CD player for fader start play and back cue.

Also, by connecting this connector to the CONTROL connector on another Pioneer DJ CD player, automatic relay play can be performed.

37. AUDIO OUT L, R connectors

RCA-type analog audio output jacks.

38. DIGITAL OUT connector

RCA type coaxial digital output connectors used to connect a DJ mixer or AV amplifier, CD player, etc., equipped with digital input connectors. The digital outputs here support all DJ and other functions, but only audio data is output (without subcodes; CD graphics are not supported).

39. POWER ■ OFF/■ ON switch**40. AC inlet (AC IN)**

Use the accessory power cord to connect this inlet to a standard AC power outlet.

Front Panel**41. Memory card indicator**

This indicator lights with a memory card is loaded and the door is closed, and flashes during memory card access.

- Do not open the door or turn off power while the indicator is flashing.

42. Memory card door and slot**43. Forced eject hole****44. Disc loading slot**

Display Section

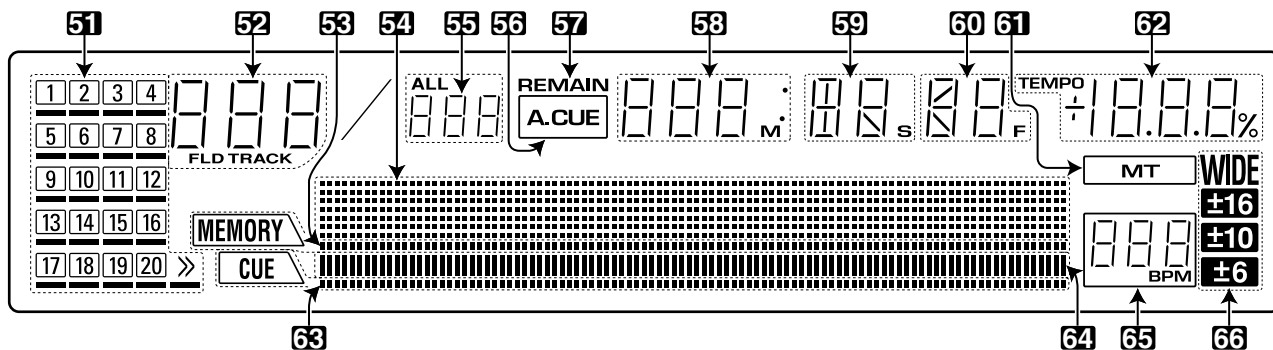

- 51. Calendar display (1 to 20, >>)**
The tracks following the currently playing track are lighted. If more than 21 following tracks are set, the >> indicator will light. An underline appears underneath track numbers for which cue points or loops have been set.
- 52. Track number/folder number display (TRACK/FLD)**
When playing an audio CD, the [TRACK] indicator lights, and the two-digit track number appears (01 to 99).
When playing MP3, [TRACK] lights and the track number is displayed (01 to 999). During folder search, the [FLD] indicator lights, and a two-digit folder number is displayed (00 to 99).
- 53. MEMORY display**
If the currently selected track includes cue memory or loop memory, the [MEMORY] indicator lights and the MEMORY display indicates the relative starting position of the cue or loop. Two dots are used to display 1 point, and even if multiple starting positions are included within a single point, only one point is displayed.
- 54. Dot matrix display (100x7 dots)**
The dot matrix is used to display TEXT, WAVE, guides and other information. Text up to 48 characters can be displayed (text longer than 16 characters is scrolled).
When WAVE display is used, the entire track is scaled so as to fit into the width of the display (100 dots width), with playback level shown across the display.
- 55. ALL track number display**
When playing an audio CD, this display shows the total number of tracks on the disc. During MP3 playback, the number of tracks inside the folder is shown.
- 56. Auto cue indicator (A.CUE)**
Lights when auto cue is ON.
- 57. REMAIN indicator**
This indicator lights to indicate that track's remaining time is being displayed.
- 58. Time (minutes) display (M)**
- 59. Time (seconds) display (S)**
- 60. Frame display (F)**
Seventy-five frames equal one second.
- 61. Master tempo indicator (MT)**
Lights when the master tempo function is ON.
- 62. TEMPO display**
Displays change in playing speed (tempo) caused by movement of the tempo adjust slider.
- 63. CUE point indicator**
When a point is recorded in the CUE button or LOOP IN button for the currently selected track, the [CUE] indicator lights and the point's relative starting position is shown in the display (2 lighted dots).
- 64. Playing address display**
To provided a quick grasp of the current track's elapsed time and remaining playing time, the entire track is shown as a bar graph scaled over the entire width of the display.
 - During elapsed time display, the bar graph's indicator segments turn on from left to right.

- During remaining time display, the bar graph indicator segments turn off from left to right.
 - When a track has less than 30 seconds of remaining play time, the graph flashes slowly; when less than 15 seconds remain, the flashing becomes quicker.
- 65. BPM display (0 to 360 BPM)**
This display shows the Beats-Per-Minute (BPM) of the currently playing track (detection range 70 to 180 BPM). The automatic BPM counter may be unable to compute the correct BPM for some tracks.
 - 66. Tempo control range display (±6, ±10, ±16, WIDE)**
Displays the variable range of the tempo adjust slider as selected with the tempo control range selector button.

Jog dial display

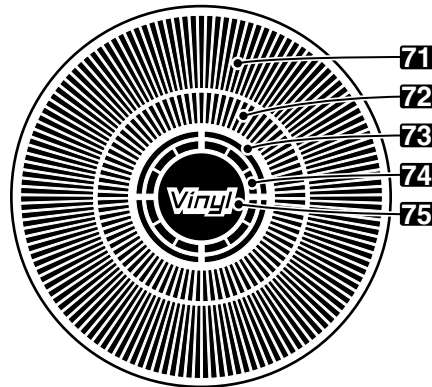

- 71. Operation display**
This display shows the relative playing position, with one revolution equivalent to 135 frames. During playback, the display rotates, and it stops during pause mode.
- 72. Cue point position indicator**
Indicates position of cue points.
- 73. Audio memory status indicator**
This indicator flashes during audio memory write, and lights when writing has been sufficiently completed. When the indicator is flashing, it may not be possible to record real time cue points, or hot cue points. The indicator also flashes when memory insufficiency occurs due to scratch operation.
- 74. Jog touch detection indicator**
In VINYL mode, this indicator lights to indicate that the jog dial surface has been touched.
- 75. VINYL mode indicator**
Lights during VINYL mode.

A



■ Lubricants List

Name	Part No.	Remarks
Grease	GYA1001 (ZLB-PN397B)	Refer to "2.3 CONTROL PANEL SECTION", "2.4 SLOT-IN MECHA. SECTION", "2.5 TRAVERSE MECHA. Assy-S".
Grease	GEM1007 (ZLB-PN948P)	Refer to "2.5 TRAVERSE MECHA. Assy-S".
Dyefree	GEM1036 (ZLX-ME413A)	Refer to "2.4 SLOT-IN MECHA. SECTION".
Grease	(ZLB-HFD1600)	Refer to "2.3 CONTROL PANEL SECTION".

B



■ Cleaning

Name	Part No.	Remarks
Cleaning liquid	GEM1004	Used to pickup lens cleaning.
Cleaning paper	GED-008	Refer to "2.5 TRAVERSE MECHA. Assy-S", "7.1.3 DISASSEMBLY".

C

D

E

F