



# Celtec User Guide

No part of this publication may be reproduced, stored in a retrieval system or transmitted, in any form or by any means, mechanical, electronic, photocopying, recording, or otherwise, without prior written permission of A&C Plastics, Inc.

© 2005 by A&C Plastics, Inc.

All rights reserved.

All information contained herein is accurate to the best of our knowledge and is provided without liability or commitment whatsoever. All recommendations or suggestions are made without guarantee, since the conditions of use are beyond our control. We recommend that you confirm the suitability of our product by carrying out tests under your local conditions and using your own mechanical equipment.

We disclaim any liability incurred in connection with the use of these data or suggestions. This publication is not to be taken as a license to operate under or a recommendation to infringe any patents. The observance of all legal regulations and patents is the responsibility of the user.

Processing and finishing techniques are presented as “typical.” Information contained herein is considered accurate to the best of our knowledge. It is offered for your consideration and investigation, and is not to be construed as a representation or warranty, expressed or implied, for which A&C Plastics, Inc. assumes any legal responsibility. Our warranties are limited to those expressly stated in written contracts or in conditions of sale. As conditions and methods of use vary and are beyond the control of A&C Plastics, Inc., A&C Plastics, Inc. disclaims any liability incurred as a result of the use of its products in accordance with the data contained on our physical properties charts or in our manual. No information herein shall be construed as an offer of indemnity for infringement or as a recommendation to use the products in such a manner as to infringe any patent, domestic or foreign.

[This page intentionally left blank.]

# Celtec User Guide

Introduction .....	i
--------------------	---

Product Availability.....	iii
---------------------------	-----

## Chapter 1 · Processing

Cutting .....	1-1
Die Cutting.....	1-1
Sawing .....	1-12
Drilling.....	1-13
Milling .....	1-14
Routing .....	1-14
Edge Finishing .....	1-15
Manufacturers .....	1-16

## Chapter 2 · Fastening

Notch Sensitivity.....	2-1
Celtec Thermal Expansion/Contraction .....	2-2
Celtec Thermal Expansion/Contraction Worksheet.....	2-3
Screwing and Nailing.....	2-5
Installation .....	2-7
Bonding and Adhesives .....	2-8
Weld-On® Adhesive Selections .....	2-10
Adhesives and Manufacturers.....	2-11

## Chapter 3 · Forming/Welding

Heat Bending .....	3-1
Pressure or Drape Forming .....	3-3
Vacuum Forming .....	3-4
Heat Welding .....	3-5
Manufacturers .....	3-8

## Chapter 4 · Graphic Applications

Cleaning / Pretreating .....	4-1
Digital Flatbed Printing.....	4-2
Painting / Varnishing .....	4-2
Vinyl Lettering.....	4-7
Specifications.....	4-8
Manufacturers .....	4-11
Addendum.....	4-12

## Chapter 5 · Special Applications

Photomounting.....	5-1
Laminating .....	5-2
Laminating Techniques.....	5-5
Manufacturers .....	5-13

## **Chapter 6 · Engineering Specifications**

Weatherability / Effects of Outdoor Exposure.....	6-1
Fire Characteristics .....	6-7
Specifications for Celtec Foam PVC Sheet .....	6-9
Standard Specifications.....	6-11

## **Chapter 7 · Material Safety Data**

I. Product Identification .....	7-1
II. Components and Hazard Classification.....	7-1
III. Physical Data .....	7-2
IV. Fire and Explosion Data .....	7-2
V. Health Hazard Information .....	7-3
VI. Reactivity Data .....	7-3
VII. Spill or Leak Procedures .....	7-4
VIII. Special Protection Information .....	7-4
IX. Shipping, Transfer and Storage .....	7-4

# Introduction

Celtec® Displayboard is a lightweight, expanded foam polyvinyl chloride (PVC) sheet material that combines the chemical resistance and fabrication capabilities of rigid PVC with a closed cell expanded core.

Celtec Displayboard is manufactured in gauges from 1mm through 25mm (1”) for use in an expanding variety of markets.

The structure of Celtec is a closed cell foam that does not absorb moisture. These features combined with its light weight and insulating characteristics (sound and thermal) make Celtec the choice material for exterior and harsh moisture environments.

Celtec Displayboard has a high quality surface for both screen and direct Digital Printing using the flatbed feed technology, as well as painting and applying vinyl graphics. It is lightweight for easy handling. It has low flammability and good chemical resistance to meet or exceed industry standards for a wide variety of applications, including exhibits, displays, signs and theater props. Celtec applications are limited only by your imagination. We are always eager to learn about new and exciting applications. Please contact our marketing department if you discover a creative new use of Celtec.

The inherent properties of Celtec eliminate time-consuming and costly surface preparation. In addition, the material can easily be cut, joined and fabricated with a wide variety of adhesives and ordinary fasteners and using readily available hand tools. Celtec can be milled and routed like wood and often more quickly. Because there are no knots, there is very little likelihood of voids or holes in the mid-wall. Celtec is free foam and therefore does not have the inherent problems of voids that the celluka process does. Celtec Displayboard has a very small cell structure, enabling superior edge finishing and routing. By varying the feed rates and speeds,

you can attain a very smooth edge. When an even smoother edge is necessary, sanding and planing can be performed, as can laminated edge finishing.

Celtec also offers superior thermal properties and low thermal conductivity as well as high insulation and sound absorption qualities. See the Engineering Specifications section of this manual for detailed information.

As a rigid and lightweight foamed PVC sheet, Celtec is excellent for the highly specialized needs of producing signage and displays as well as booths and stage sets. Other applications include photo mountings and building materials. As a USDA-approved product, Celtec can be used wherever food is processed or sold. Celtec Displayboard is free of lead, barium and cadmium. And as the first foamed PVC to be U.L. Classified, Celtec meets all three U.L. 1975 fire test requirements, minimizing the risk of both heat conduction and fire.



# Product Availability

All information contained herein is accurate to the best of our knowledge and is provided without liability or commitment whatsoever. We recommend that you confirm the suitability of our product by carrying out tests under your local conditions and using your own mechanical equipment.

Custom colors, sizes, gauges, tolerances and formulations are available upon request and with a minimum order.









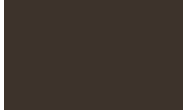

Actual color may vary from production run to production run. Because of limitations in printing, precise color may be different from the samples shown below.

## Color Samples

### NOTE!

PMS numbers are an approximation to provide designers with a color range. Actual color may be different from printed samples shown below.

www.acplasticsinc.com www.acplasticsinc.com

Color	Sample	PMS	RGB	CMYK	HTML
White		0	R : 0 G : 0 B : 0	C : 0 M : 0 Y : 0 K : 0	#FFFFFF
Black		Black	R : 61 G : 51 B : 43	C : 60 M : 63 Y : 70 K : 60	#3D332B
Grey		Gray 8C	R : 136 G : 138 B : 140	C : 0 M : 0 Y : 0 K : 56	#888A8C
Cool Grey		Cool Grey 4	R : 196 G : 193 B : 186	C : 23 M : 19 Y : 24 K : 0	#C4C1BA
Beige		Beige 400	R : 209 G : 198 B : 181	C : 18 M : 19 Y : 27 K : 0	#D1C6B5
Yellow		Yellow 123	R : 255 G : 198 B : 30	C : 1 M : 22 Y : 95 K : 0	#FFC61E
Green		Green 355	R : 0 G : 158 B : 73	C : 84 M : 11 Y : 100 K : 1	#009E49
Red		Red 187	R : 175 G : 30 B : 45	C : 22 M : 100 Y : 90 K : 13	#AF1E2D
Blue		Blue 287	R : 0 G : 56 B : 147	C : 100 M : 69 Y : 0 K : 11	#003893
Light Blue		Light Blue 2935	R : 0 G : 91 B : 191	C : 90 M : 68 Y : 0 K : 0	#005BBF
Orange		Orange 21	R : 239 G : 107 B : 0	C : 2 M : 71 Y : 100 K : 1	#EF6B00
Violet		Violet C	R : 102 G : 7 B : 165	C : 94 M : 91 Y : 0 K : 0	#6607A5

## Celtec Displayboard – Product Availability

Celtec Displayboard is a rigid foamed PVC sheet with a satin finish. Celtec is available in twelve (12) standard colors and gauges from 1mm to 25mm. The tables below show the product availability for 1mm – 6mm and 10mm – 25mm.

Color (PMS)	Available Thicknesses (metric) / Sheet Sizes (inches)					
	1 mm	2 mm	3 mm	4 mm	5 mm	6 mm
White	48x96	48x96 48x120 60x120	48x96 48x120 60x96 60x120	48x96	48x96	48x96 48x120 60x96 60x120
Black	48x96	48x96 48x120 60x120	48x96 48x120 60x96 60x120		48x96	48x96 48x120 60x96 60x120
Grey (8C)			48x96			48x96
Cool Grey (4C)			48x96			48x96
Beige (400C)			48x96			48x96
Yellow (123C)			48x96			48x96
Green (355C)			48x96			48x96
Red (187C)			48x96			48x96
Blue (287C)			48x96			48x96
Light Blue (2935C)			48x96			
Orange (21C)			48x96			
Violet (Violet C)			48x96			
Ultra Fade-Resistant Red			48x96			48x96
Ultra Fade-Resistant Blue			48x96			48x96

## Celtec Displayboard 10mm – 25mm

Color (PMS)	Available Thicknesses (metric) / Sheet Sizes (inches)				
	10 mm	12 mm	15 mm	19 mm	25 mm
White	48x96 48x120	48x96 48x120 60x120	48x96 48x120	48x96 48x120	48x96 48x120
Black	48x96	48x96 48x120		48x96 48x120	48x96 48x120
Grey (8C)	48x96 48x120	48x96 48x120			

# Processing

# 1

---

This chapter details various methods of cutting Celtec® as part of processing the material into its final form. Common metal and woodworking tools and machinery can be used, depending on the specific application for the finished product.

## Cutting

Sheets of Celtec up to 3 mm thick can be cut with a utility knife. To cut sheets thicker than 3 mm, band saws, table saws and panel saws can be used, as detailed later in this chapter. Power shears and guillotines can crush the edges of Celtec sheets and generally produce unacceptable results.

With any cutting procedure, frictional heat can build up and produce unacceptable results on cut edges. Rough edges can also occur from cutting the Celtec using inadequate support or from using worn tooling. For best results, test the machine setups and cutting processes before beginning production.

### NOTE!

Celtec's density is approximately half the density of conventional PVC, which makes it compress relatively easily.

## Die Cutting

When Celtec sheets are used for mass producing flat shapes or cutouts, die cutting is the most commonly employed fabrication technique. Celtec is an ideal material for die cutting, producing a clean, smooth edge without splintering or cracking. Die cutting is recommended for a wide range of applications, including letters, openings within larger sheets of Celtec,

puzzle pieces and assemblies that fold into three-dimensional shapes, such as point-of-purchase (POP) displays (Figure 1a).

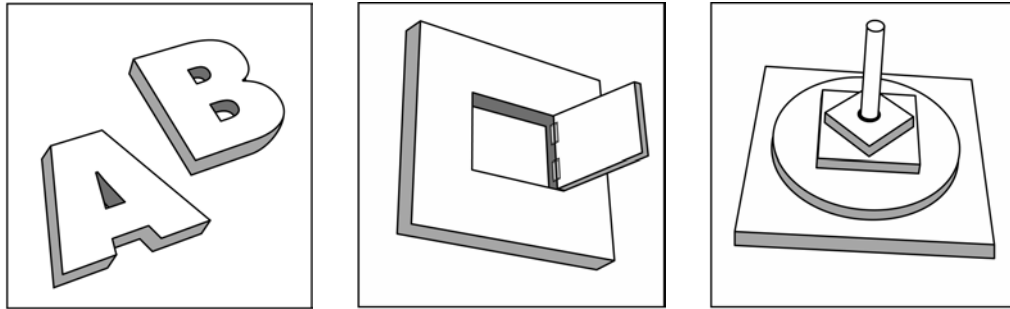

▲ **Figure 1a:**

Die cutting is recommended for a wide range of applications such as letters, puzzle pieces and assemblies or displays finished into 3-D shapes.

To improve processing efficiency, Celtec sheets can be painted, printed or silkscreened prior to die cutting. After die cutting, the Celtec sheets or pieces can be finished by heat bending, fastening, gluing or machining.

**NOTE!**

Test the die cut suitability of the Celtec material before painting or silkscreening an entire production run.

Of the various die cutting methods available, the most frequently used method is Steel Rule Die Cutting, in which the steel rule die (SRD) functions very much like a cookie cutter.

SRDs are constructed from one-inch wide strip steel, available in 500-foot coils, with one presharpener edge. The thickness of the strip steel can be specified by a **point** designation, with one point equaling 0.014 inches. To cut Celtec with an SRD, the recommended thickness of strip steel ranges from 2 points (0.028 inches) to 6 points (0.084 inches). The most commonly used strip steel thicknesses for cutting Celtec are 3 points (0.042 inches) and 4 points (0.054 inches).

To construct the die, lengths of strip steel are first cut from the coil. These cut lengths, called **knives**, are then bent to the desired shape or pattern to be cut and embedded in a maple block, called a **die body**.

The SRD assembly is mounted under the top platen of the press. The Celtec sheet is then placed on a steel bottom platen. When pressure is applied, the knives of the SRD are forced through the Celtec, producing a **cut**.

Hydraulic platens or “clicker” presses are used to supply the necessary pressure for the cut. After the cut, the platens are separated, and the sheet or cutouts are removed. At this point, any finishing work required can begin.

To help eject the cut Celtec, strips of a resilient, compressible material, such as open cell foam rubber, can be glued next to the knives (Figure 1b). The strips should extend about 1/16 inch beyond the cutting edge of the knife. Strips of the same material can be used to secure the Celtec sheet in position by gluing the strips to the top or bottom platen of the press.

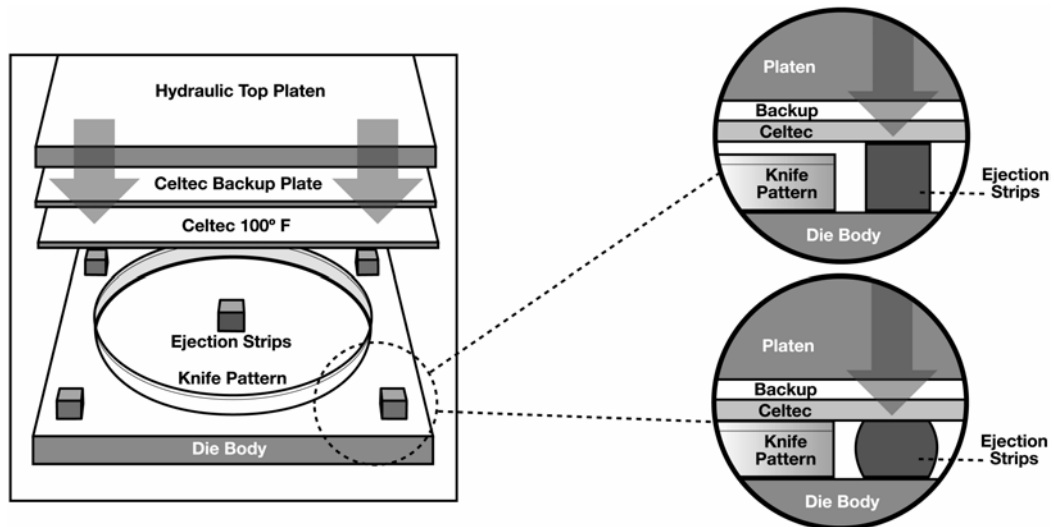

▲ **Figure 1b:**

Strips of a resilient material help eject Celtec material from the die.

**NOTE!**

For best results, dull or worn knives should be replaced as needed with new ones.

### Factors affecting die cut quality

**Temperature of the Celtec material** Celtec is a thermoplastic, which has a tendency to be more brittle at lower temperatures. When the Celtec sheet temperature is below 75°F, the first two-thirds of the cut is clean, while the

last third exhibits fracturing. When the Celtec material is heated above 75°F, the quality of the cut improves, and fracturing is reduced. The best result is achieved when Celtec is preheated to 100°F.

TIP ▶

For complex die cut parts, a higher temperature during cutting will reduce the likelihood that fracturing of the Celtec will occur.

**Sheet thickness** The quality of the die cut is also affected by the material's thickness. The best cuts are produced using Celtec sheets of 3 mm or less. Die cuts in Celtec sheets over 4 mm tend to exhibit deformation, roughness along the cut edge and/or fractures in the material. To cut Celtec:

1. Verify that the SRD has the proper point value and bevel
2. Preheat the material to 100°F
3. Select the appropriate backup plate
4. Maintain a sharp cutting edge

For material over 4 mm thick, additional steps, such as sanding or routing, may be necessary after die cutting to smooth any rough edges produced by the cut.

The thickness of the Celtec material will also affect the quality of the die cut when the piece has one or more small radii. As the thickness increases, the difficulty involved in producing smooth cuts with small radii also increases. Sheets 4 mm thick or less can be die cut using a radius as small as 1/8 inch.

**Knife thickness** As the knife edge penetrates the Celtec, it exerts an enormous compressive force, which can produce deformation, or rounding, of the material's corners. The knife's penetration also creates a shearing force which tends to cause fracturing of the material approximately two-thirds of the way through the Celtec sheet. Applications that require cutting of narrow radii or U-shaped tabs are highly susceptible to shearing because of the severe lateral pressure.

The selection of a correct **gauge** (point thickness) for the knife material is critical for any die cutting operation. For example, straighter, smoother cuts involving small radii are more readily achieved using a thinner rather than thicker gauge knife steel, assuming that both knives have the same bevel configuration and angle. However, a thinner knife is more vulnerable to warping, bending or breaking because of the extreme compression when the Celtec is thick, especially when the sheet is below 100°F.



TIP ▶

A thinner gauge knife will not require as high a sheet temperature to produce equivalent quality die cuts because a thinner knife encounters less resistance and creates a cleaner edge on the cut Celtec. A thicker knife will require that the Celtec be heated to make it more flexible and less brittle in order to create a similar die cut quality.

The appropriate die knife thickness is directly related to the thickness of the Celtec material being cut. If the knife is too thin for the thickness of the Celtec, the knife is prone to breaking. If it is too thick, the knife tends to deform the Celtec material.

When die cutting Celtec sheets, use the following guidelines to determine the appropriate knife size.

- For most common applications, a 3-point or 4-point (0.042" or 0.056") knife is recommended.
- For cutting complex parts in sheet material less than 4 mm, a 2-point (0.028") knife is recommended.
- For sheets over 6 mm or for wide separating cuts, a 6-point (0.084") knife is recommended.

**Correct bevel selection** Knife bevels vary according to length and type. Bevel length is defined as the distance from the tip to the end of the honed surface. When cutting Celtec, the length of the bevel should be between 3/16 and 1/4 inches (Figure 1c).

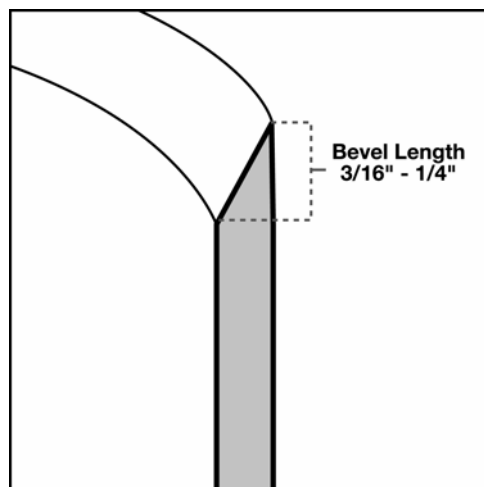

◀ **Figure 1c:**  
Bevel length.

TIP ▶

In general, the longer the length of the bevel, the smoother the resulting cut.

The bevel can be one of three basic types: center, inside or outside. A **center bevel** is honed from both sides, producing a V-shaped point with each leg of the V being equal. A modified center bevel, or **facet cut bevel**, is recommended for cutting Celtec. To create a facet cut bevel, the V of a center bevel is honed a second time, giving the lead cutting edge a more obtuse angle (Figure 1d).

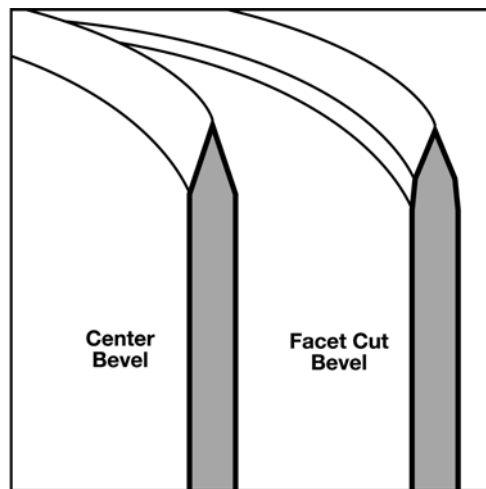

◀ **Figure 1d:**  
The two types of center bevels.

With either a center bevel or a facet cut bevel, the longer the bevel length and the thinner the knife, the more vertical the perimeter cut.

TIP ▶

When both the inside and outside parts of a cut must be used, such as with jigsaw puzzle pieces, a center bevel is suggested because the resulting cut is wedge-shaped, thus giving both the inside and outside pieces an identical, sloped cut.

An **inside bevel** has the honed side on the outside of the cut (the scrap side), while the straight, unhoned side is on the inside of the cut, or “good side.”

An **outside bevel** reverses an inside bevel. It produces a straight cut on the inside, or good part, and a sloping cut on the periphery, or scrap side (Figure 1e).

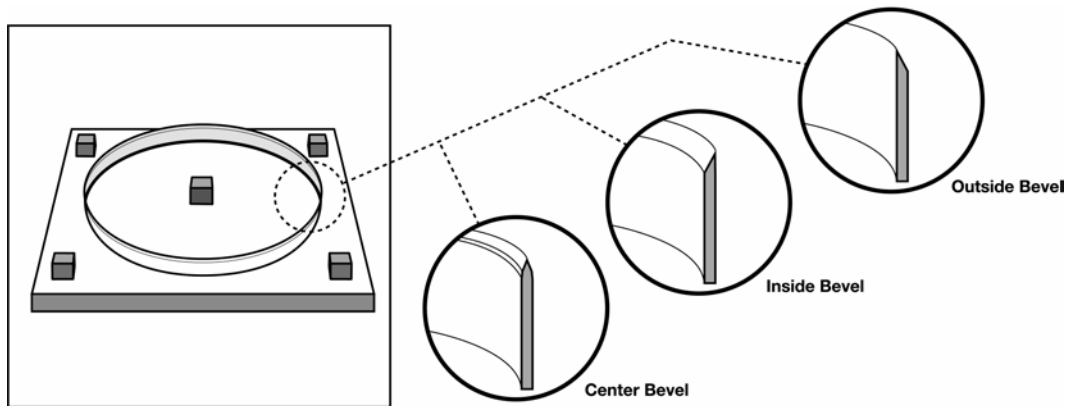

▲ **Figure 1e:**

Typical bevels are designated as inside, outside or center, depending on where the honed surface of the knife faces in relation to the finished shape.

**Bevel sharpness** Steels used for SRDs have a hardness of 57-59 Rockwell C. After much use, however, the knife will dull and produce cuts of increasingly poor quality. Resharpener knives is not recommended because it frequently results in an uneven edge and knife depth, even when the sharpening is performed by a skilled machinist. Even a slightly uneven edge will result in unequal penetration of the Celtec material and thus in a ragged cut.

**TIP** ▶

Do not resharpen knife blades. Always replace dull or worn knives with new ones to ensure even cuts.

**The backup plate** Steel is often used to fabricate backup plates because the plate must not be too soft. However, steel plates can sometimes cause incomplete penetration of the Celtec, which also causes the material to fracture at the end of the cutting stroke. One method of avoiding this problem is to use a backup plate made from a sheet of Celtec or of chipboard placed over the steel backup plate. These softer materials enable the die to penetrate about 1/10 inch beyond the Celtec sheet, producing a cleaner cut (Figure 1f).

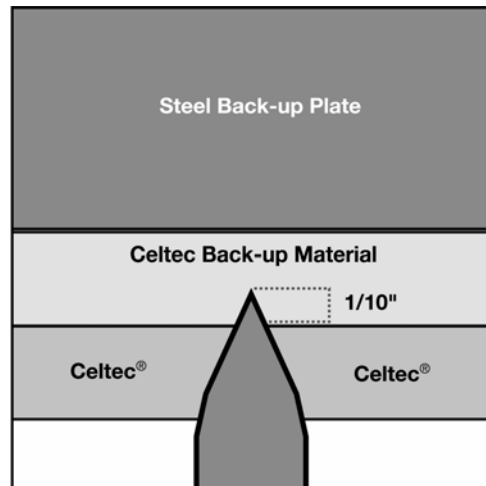

◀ **Figure 1f:**

A backup plate made of Celtec or chipboard enables the die to penetrate the Celtec material to be cut.

**Make ready** Because of slight variations in thickness of a backup plate, the degree of knife penetration may vary throughout the cut. In order to produce a uniform cut, the backup plate should be built up to achieve even penetration by the die. The process of building up the backup plate to eliminate unevenness is called **make ready**, as explained below.

**Make ready steps for die cutting:**

1. Securely mount the SRD on the upper or lower platen, as required, ensuring that it will not move during the die cutting.
2. On the opposite platen, firmly mount the die cutting plate, which should be 1/16 to 1/8 inches thick.
3. Using thin paper, such as Kraft wrapping paper, prepare the **make ready sheet**, which should be the exact size of the cutting plate. Position the make ready sheet on top of the cutting plate.

**NOTE!**

**IMPORTANT!** Before proceeding, make certain that the press is not out of square (Figure 1g).

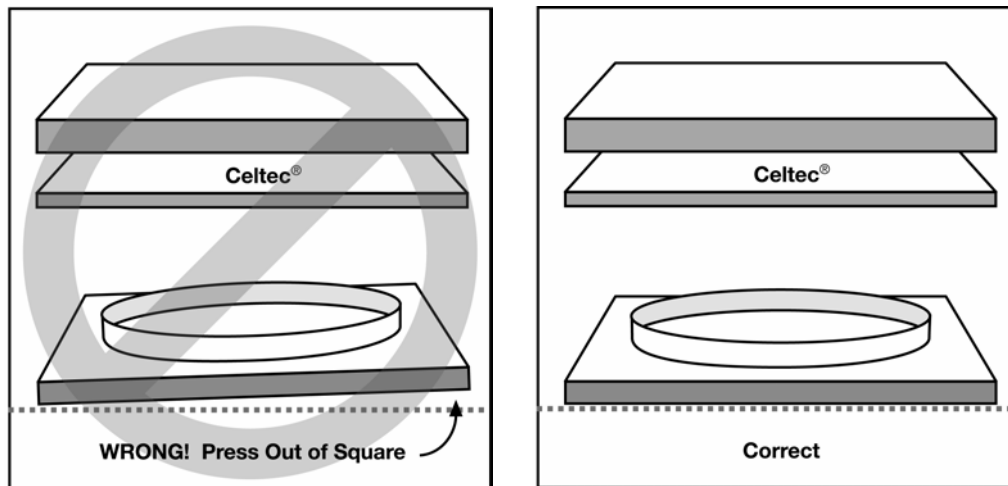

▲ **Figure 1g:**

Proper alignment of SRD die presses is very important in obtaining optimum results.

4. Engage and adjust the press so that the die just touches, or “kisses”, the cutting plate. The die should leave an impression on the paper **without** leaving an impression on the plate. Usually only about two-thirds of the die pattern will leave its impression on the paper.

TIP ▶

Do not attempt to make a complete impression of the die cut during this step.

5. After the kiss cut, transfer the make ready sheet from the top of the cutting plate to beneath the cutting plate, taking care that it is placed in the identical position in the press. Keeping the paper in the press will ensure that the exact knife depth required to cut the Celtec cleanly, as established in Step 4 with the paper in place, is maintained (Figure 1h).

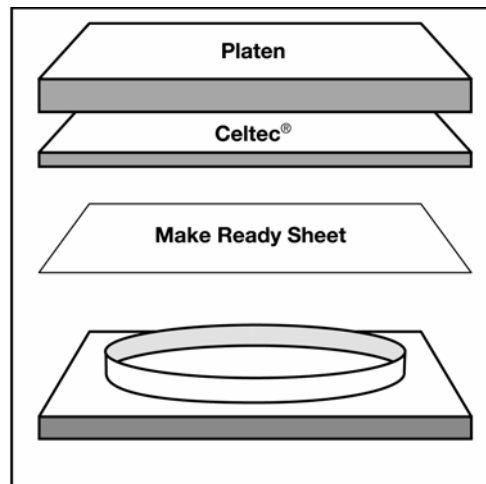

◀ **Figure 1h:**

The make ready sheet must be identical to the size of the platen.

6. Place a sheet of Celtec in the press and strike a part. If, upon inspection, you find an incomplete impression, the press can be lowered. Be sure, however, that the die just contacts the cutting plate.
7. Examine the cut Celtec. If portions of the perimeter have rough edges, follow the steps below:
  - a. Remove the make ready sheet from beneath the cutting plate. Using the die-cut sample made in Step 6 as a guide, place single layers of cellophane tape on the make ready sheet in all areas where the cut is not clean. This selective taping will improve the cutting action in the problem areas.

**NOTE!**

Use a single layer of tape only. Do not overlap the tape strips or add tape to areas that are already cutting cleanly. Tape strips, or shims, may also be necessary in areas in which the pattern to be die cut is intricate or has sharp bends and corners.

- b. Re-insert the taped make ready sheet under the cutting plate and strike another sample, making certain that the cut just penetrates the Celtec sheet. If the cut is satisfactory, production is ready to begin. If roughly cut areas persist, repeat the taping procedure.

## Make Ready Tips

- When dies include intricate patterns and/or sharp bends, more pressure will be required to make the cut. Additional tape shims to build up the cutting plate may be needed in these areas (Figure 1i).

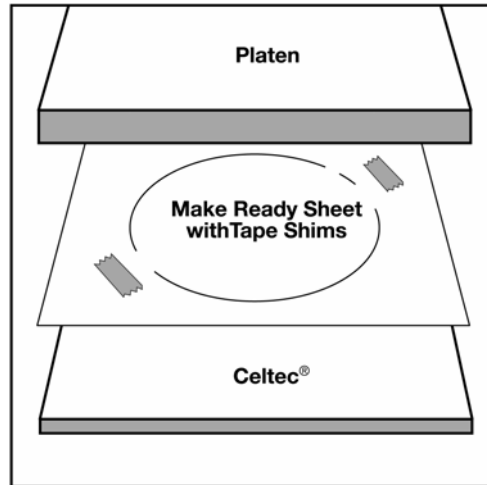

◀ **Figure 1i:**

Tape shims may be required where patterns to be die cut are intricate or have sharp bends and corners.

- Once the die is cutting cleanly, the make ready sheet should last throughout the entire job. If necessary, however, small imperfections can be rectified by applying additional cellophane tape to the specific problem areas.

### NOTE!

**IMPORTANT!** Do not attempt to remedy cutting problems by shimming the back of the die. It is difficult to locate the exact area for tape placement, and in most cases, the die will wear through the tape and ruin the make ready sheet.

- On completion of the job, file the make ready sheet together with the die. This will reduce setup time if the job is rerun.

## Sawing

**Circular Saws** For Celtec sheets 3 mm and thicker, carbide-tipped, triple chip ground type circular saws can be used (Figure 1j). The following settings are recommended:

- Rake angle:  $0^{\circ}$  to  $15^{\circ}$
- Clearance angle:  $10^{\circ}$  to  $20^{\circ}$
- Cutting speed: 8,000 to 12,000 feet per minute
- Feed: 70 to 90 feet per minute
- Tooth pitch: 0.080" to 0.040"

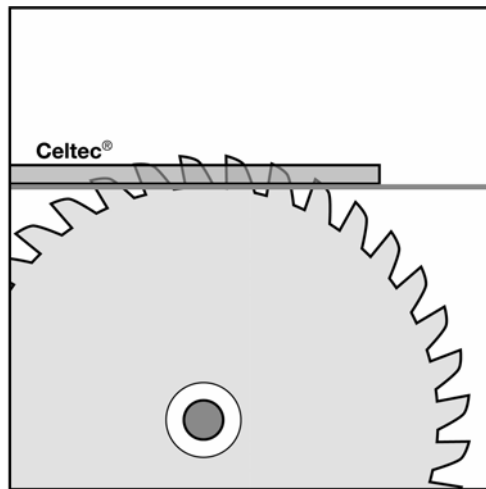

◀ **Figure 1j:**  
Circular saw blade usage.

**Band Saws** High speed steel blades normally recommended for wood or plastic (hook type) can be used for Celtec material within the following guidelines.

- 4 to 8 teeth per inch
- Cutting speed: 3,000 to 5,000 feet per minute
- Feed: up to 40 feet per minute

**Saber Saws** Rough cut type blades ground for plastics can be used on Celtec sheets. Smooth metal-cutting blades, however, will not produce acceptable results.



## Drilling

Celtec can be drilled with carbide-tipped bits using twist drills recommended for metals (Figure 1k). The following settings are recommended:

- Point angle: between  $90^{\circ}$  to  $110^{\circ}$
- Spiral angle:  $30^{\circ}$
- Relief angle:  $10^{\circ}$
- Cutting speed: 150 to 1,300 feet per minute
- Feed rate: 0.01 to 0.02 inches per revolution

Removing the drill from the Celtec material periodically may be necessary when drilling deeper holes so that frictional heat does not build up. Drill bits ground for normal rigid PVC will not produce acceptable results.

TIP ▶

For best results, drill bits should be kept sharp at all times.

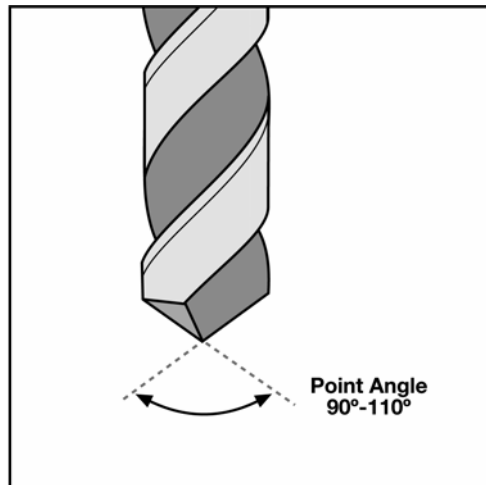

◀ **Figure 1k:**  
Drill grinding specifications.

## Milling

Celtec can be milled by using standard milling machines of various types within the following guidelines (Figure 11).

- Relief angle:  $5^{\circ}$  to  $10^{\circ}$
- Rake angle:  $-10^{\circ}$  to  $0^{\circ}$
- Cutting speed: 3,000 to 3,500 feet per minute
- Cutting feed: 0.12 inches per revolution

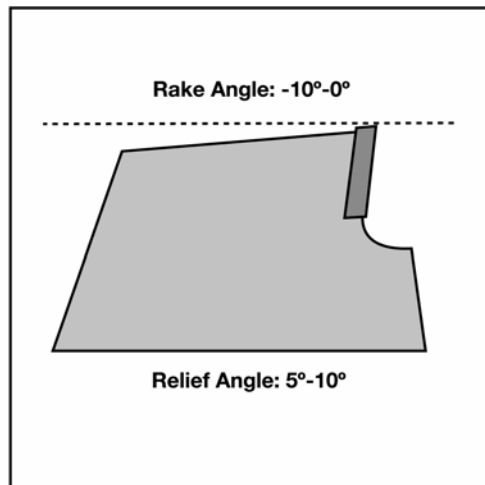

◀ **Figure 11:**  
Helical milling cutter.

## Routing

Celtec material can be easily routed using multi-fluted carbide tools on standard woodworking routers. Standard tools and machines can be utilized without having to alter equipment bits (Figure 1m). Adjust feeds and speeds as needed to achieve the best edge finish on the Celtec parts.

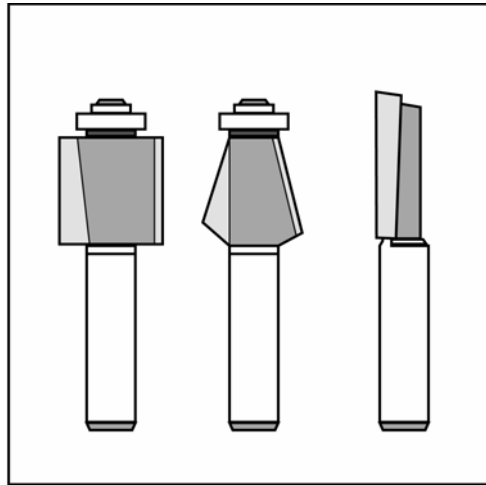

◀ **Figure 1m:**  
Standard router bits.

## Edge Finishing

Edge finishing of Celtec can be accomplished using various sanding, filing or grinding tools, such as a sander or file. Be careful to not overheat surfaces. Slight cell structure may be visible on cut edges of the Celtec material.

**TIP** ▶

Important! When machining Celtec material, secure hold downs so that the force is spread out over a large area.

## Manufacturers

### Sawing Equipment

Company	Telephone	Address
Forrest Manufacturing Company www.stores.yahoo.com/forrestman	973.473.5236 Fax 973.471.3333	457 River Road Clifton, NJ 07014
Hendrick/RWH Industries, Inc. www.hendrickmfg.net	978.741.3600 Fax 978.744.0242	36 Commercial Street Salem, MA 01970
Holzma US www.stilesmachinery.com	704.861.8239 Fax 704.867.4140	1200 Tulip Drive Gastonia, NC 28052

### Die Cutting Equipment

Company	Telephone	Address
Brantzen and Klugy	715.483.3265 Fax 715.483.1640	539 Blanding Woods Road St. Croix Falls, WI 54024
J. A. Richards Company www.jarichards.com	800.253.3288 616.343.4684 Fax 616.343.9133	903 Pitcher Street Kalamazoo, MI 49007
Thomson National Press Co. www.thethomsongroup.com	508.528.2000 Fax 508.528.6869	115 Dean Avenue Franklin, MA 02038

### Router Equipment

Company	Telephone	Address
Onsrud Cutter LP www.onsrud.com	800.234.1560 847.362.1560 Fax 800.557.6720	800 Liberty Drive Libertyville, IL 60048

# Fastening

# 2

---

In this chapter, various methods of fastening Celtec® are covered as well as important details to consider during the fabrication process. With the numerous uses for Celtec and the differing environments of service, it is important to take into account Celtec's thermoplastic properties during fabrication and installation.

## **Notch Sensitivity**

When designing a Celtec part, it is important to maintain a smooth radius corner along the perimeter edge or in slotted areas (Figure 2a). Using a sharp corner angle or scored line is not recommended and can result in fracturing of the Celtec material. With thinner sheets of Celtec, radii as small as 1/8" generally can be cut without difficulties.

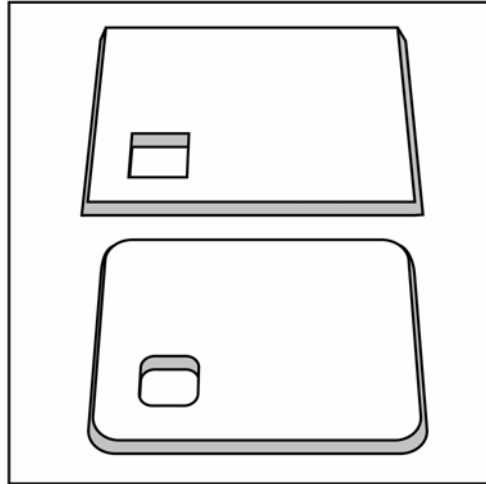

◀ **Figure 2a:**

Sharp angles should be avoided in designing Celtec parts.

The correct procedure is to maintain a smooth inner or outer radius.

## Celtec Thermal Expansion/Contraction

Because it is a cellular, or foamed, rigid polyvinyl chloride sheet product, Celtec will expand or contract with an increase or a reduction in temperature, as is common with all plastic materials. When the temperature change is reversed, the material returns to its original dimensions. This property is called **linear thermal expansion and contraction**.

Because Celtec can be used in a wide variety of indoor and outdoor applications, linear thermal expansion and contraction may need to be considered during the fabrication and installation of the material. Important variables are the temperature at which the Celtec was machined as well as the temperature range of the environment in which the Celtec is installed.

In a location with a relatively constant temperature and not in direct sunlight, such as an indoor display stand, any thermal expansion and contraction of the Celtec material will usually not be significant.

If, however, a finished Celtec project will be used in a setting that has noticeable fluctuations in temperature, the potential expansion and contraction should be considered when producing the part(s). Expansion of the Celtec material occurs when it is placed in an environment with higher temperatures than the temperature at which it was originally cut.

Conversely, contraction, or shrinkage, of the material takes place when it is in a colder environment than that in which it was cut.

**NOTE!**

Calculations for thermal expansion and contraction should be made for both the width and the length of the Celtec material.

Celtec should not be used in areas that exceed 140°F, at which temperature the Celtec will soften and change dimension permanently. **Dark colors are generally not recommended for outdoor use, as they absorb heat energy and can easily exceed the maximum allowable temperature of 140°F.**

**NOTE!**

When exposed to direct sunlight, white Celtec will generally show a surface temperature 10° to 20° higher than the actual air temperature.

## Celtec Thermal Expansion/Contraction Worksheet

The following worksheet will help calculate the correct size to cut a Celtec part in order to allow for potential expansion and contraction after installation.

<b>Expansion:</b>	
1. Highest expected temperature in the environment in which the Celtec part will be used (in degrees Fahrenheit)	°F
2. Approximate temperature of the Celtec part at the time it was cut (in degrees Fahrenheit)	°F
3. Total temperature difference (subtract line 2 from line 1)	°F
4. Total length of Celtec part (in inches)	in.
5. <b>Total amount of expansion</b> (line 3 x line 4 x 0.00004)	<b>in.</b>

<b>Contraction:</b>	
1. Approximate temperature of the Celtec part at the time it was cut (in degrees Fahrenheit)	°F
2. Lowest expected temperature in the environment in which the Celtec part will be used (in degrees Fahrenheit)	°F
3. Total temperature difference (subtract line 2 from line 1)	°F
4. Total length of Celtec part (in inches)	in.
5. <b>Total amount of contraction</b> (line 3 x line 4 x 0.00004)	<b>in.</b>

**Conversion Table: Decimal to Fractional Inches**

0.032"=1/32"	0.156"=5/32"	0.281"=9/32"	0.406"=13/32"
0.063"=1/16"	0.187"=3/16"	0.312"=5/16"	0.438"=7/16"
0.093"=3/32"	0.218"=7/32"	0.343"=11/32"	0.469"=15/32"
0.125"=1/8"	0.250"=1/4"	0.375"=3/8"	0.500"=1/2"



### Celtec Thermal Expansion/Contraction Worksheet Example:

A Celtec part is cut in a shop where the temperature is 70°F. The part is 96 inches long. The part will be installed as part of an outdoor sign on a concrete building. The highest expected temperature after installation is 100°F, and the lowest expected temperature is 10°F.

<b>Expansion:</b>	
1. Highest expected temperature in the environment in which the Celtec part will be used (in degrees Fahrenheit)	100°F
2. Approximate temperature of the Celtec part at the time it was cut (in degrees Fahrenheit)	70°F
3. Total temperature difference (subtract line 2 from line 1)	30°F
4. Total length of Celtec part (in inches)	96 in.
5. <b>Total amount of expansion in inches</b> (line 3 x line 4 x 0.00004)	<b>0.115 in.</b>
<b>Contraction:</b>	
1. Approximate temperature of the Celtec part at the time it was cut (in degrees Fahrenheit)	70°F
2. Lowest expected temperature in the environment in which the Celtec part will be used (in degrees Fahrenheit)	10°F
3. Total temperature difference (subtract line 2 from line 1)	60°F
4. Total length of Celtec part (in inches)	96 in.
5. <b>Total amount of contraction in inches</b> (line 3 x line 4 x 0.00004)	<b>0.230 in.</b>

Using the worksheet and converting the results to fractional inches, the maximum amount of expansion of the 96" part will be approximately 1/8", and the minimum amount of contraction will be approximately 1/4". To allow for this expansion and contraction, the Celtec sign should not be fastened directly to the concrete exterior wall, as it might then buckle, crack or warp during temperature fluctuations. In this example, slots for fasteners

or U-channel tracking should be cut to allow the part to expand up to 96-1/8" and contract to 95-3/4".

<b>Celtec Linear Expansion/Contraction Quick Reference:</b>				
<b>Total Temperature Change (+/-)</b>	<b>Expansion / Contraction of Material at Standard Lengths / Widths (in inches)</b>			
	<b>48 Inches</b>	<b>60 Inches</b>	<b>96 Inches</b>	<b>120 Inches</b>
20°F	0.038	0.048	0.076	0.096
40°F	0.077	0.096	0.154	0.192
60°F	0.115	0.144	0.230	0.288
80°F	0.154	0.192	0.308	0.384
100°F	0.192	0.240	0.384	0.480
120°F	0.230	0.288	0.460	0.576
140°F	0.269	0.336	0.538	0.672

## Screwing and Nailing

Any type of screw or nail can be used to fasten Celtec material; pre-drilling is typically unnecessary. Power nailers and screw driving equipment are suggested. Inserting the screw or nail in an elongated slot or an oversized hole is recommended so that the material can expand or contract if fluctuations in temperature occur (Figure 2b). For best results, use oversized washers or grommets in combination with screws.

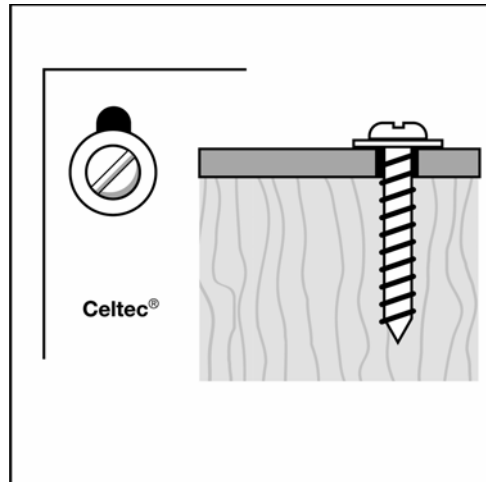

◀ **Figure 2b:**  
Elongated or oversized holes  
are recommended for use with a  
screw or bolt.

Screws should be tightened and then retreated slightly to allow the Celtec material to expand or contract as necessary.

In small panels under 18 inches or in temperature-controlled environments, allowing for expansion and contraction is not mandatory. Mechanical failures in heating or cooling systems and other unexpected factors can, however, affect temperatures radically and may cause unanticipated expansion or contraction.

Nailing is suggested for small, thin panels of Celtec material. To use larger nails and screws, holes should be placed at least one inch from any edges and predrilled (Figure 2c). Celtec is more brittle in colder temperatures, so if work is being completed outdoors in low temperatures, be careful to avoid possible fracturing of the Celtec material.

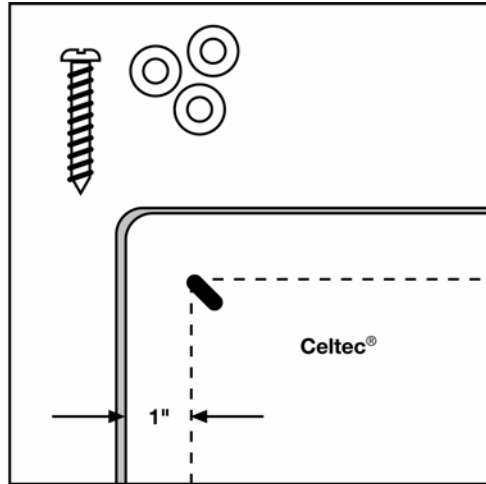

◀ **Figure 2c:**  
Screwing recommendations for  
Celtec.

## Installation

Celtec is manufactured as an extruded PVC product with a directional grain running the entire length of the sheet. This manufacturing process gives Celtec greater flexural strength in the direction of the extrusion. Because of this characteristic, flag-type signs should be cut so that the grain direction is horizontal to the anchor point (Figure 2d). This precaution permits the Celtec material to flex and withstand wind pressure.

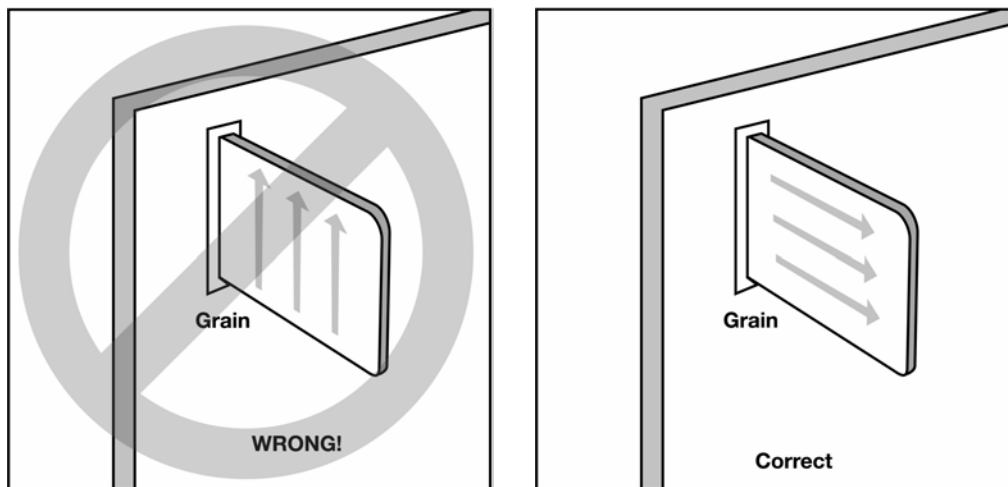

**▲ Figure 2d:**

The grain of the Celtec material should be perpendicular to the attachment point.

**NOTE!**

Failure to cut and attach the material in the proper direction may cause fracturing to occur, particularly in narrow signs.

## Bonding and Adhesives

### Celtec to Celtec or other PVC material

For bonding Celtec to itself or another PVC material, a solvent-based adhesive system used for rigid, non-expanded PVC will provide the best results. Solvent-based adhesives are sold through various suppliers. Proper ventilation and a clean working environment are essential for this type of bonding.

**NOTE!**

When bonding large panels face to face, avoid using solvent-based adhesives, which will not cure properly.

### Celtec to various substrates

There are numerous types of adhesives that can be used with specific substrates. Contact, epoxy, rubber-base and urethane adhesive systems are all acceptable. For best results, test the selected adhesive for suitability in a particular application before general use.

Parts to be joined should fit without forcing and be prepared with appropriate cleaner. Depending on the type of application and the consistency of the adhesive, the adhesive can be applied to the material with a brush, a syringe or an eyedropper. If cement is applied to one surface, let the two surfaces be in gentle contact for a few seconds to allow the cement to soften the dry surface, then press parts together in firm contact (Figure 2e).

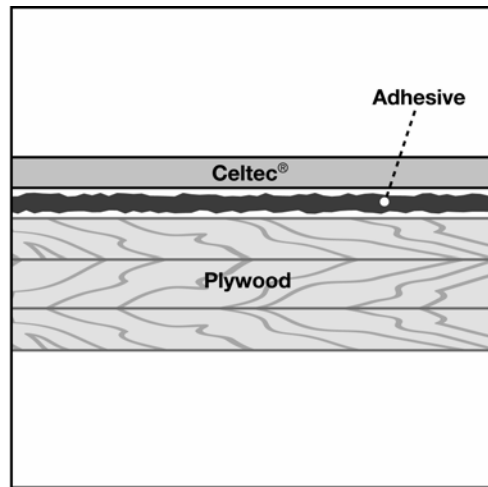

◀ **Figure 2e:**  
Bonding Celtec to another  
substrate.

**NOTE!**

When using any adhesive system, be certain to follow the manufacturer's storage and handling recommendations. Disposing of spent adhesives or solvents may be subject to local regulations.

## **Weld-On® Adhesive Selections**

The table below details the individual Weld-On® adhesives best used to bond Celtec to various materials.

Celtec Material Bonding Chart									
Material	Weld-On Product Number								
	10	16	40	42	45	66	1784	1802	2007
ABS		X	X	X	X				
Acrylic Cell Cast		X	X	X	X				
Acrylic Cross-Linked			X	X	X				
Acrylic Extruded		X	X	X	X				
Butyrate		X	X	X	X				
Concrete	X				X				
Fiberglass	X				X				
Metal	X				X				
PETG		X	X	X	X				
Polycarbonate		X	X	X	X				
Polyester	X		X	X	X				
Polyurethane						X	X		
PVC (Rigid)		X	X	X	X				X
PVC (Flexible)					X				X
PVC (Foamed)		X	X	X	X				X
Styrene		X			X			X	
Wood					X				

Weld-On Product Number	Color	Body	Typical Viscosity (cps)	Typical Sp. Gr.
10	White	Two-part, reactive, high strength, structural adhesive	40,000	1.03
16	Clear	Fast-drying, high strength, acrylic plastic cement	800	1.08
40	Clear	Two-part, reactive, high strength acrylic cement	2,900	1.03
42	Clear	Two-part, reactive, high strength, acrylic cement	2,900	1.03
45	Off-white	Two-part, reactive, high strength, structural adhesive	500,000	1.10
66	Clear	Thin, fast-drying, flexible, vinyl contact cement	260	0.85
1784	Clear	High strength, water- and weather-resistant cement	450	0.92
1802	Clear	Thin bodied acrylic plastic cement	2,900	0.89
2007	Clear	Fast-drying solvent cement	Water Thin	0.85

Weld-On® is a registered trademark of IPS Corporation (455 W. Victoria Street, Compton, CA 90220 USA)  
310.898.3300, Fax 310.898.3392, Toll-free 800.421.2677, www.ipscorp.com)



## Adhesives and Manufacturers

The first table below lists several adhesives and their bonding applications for materials commonly used in fabricating Celtec products. The second table contains contact information for the manufacturers of those products. Additional adhesive manufacturers are listed in the third table.

The listed adhesives and manufacturers are for informational purposes only. Please perform the appropriate tests to ensure that the materials will produce the desired results.

Celtec Recommended Adhesives and Applications								
Manufacturer	Adhesive	Celtec to:						
		Celtec	Other Plastics	Glass	Aluminum	Metal	Wood/ Hardboard	High Pressure Laminates
3M Adhesives Division	3M Scotch-Weld 2216B/A, 3549 B/A (structural bond)	X	X			X		
	3M Scotch-Grip 4475, Fast Bond 30 Neutral (nonstructural bond)						X	
	Fast Bond 30-NF Green Contact Adhesive	X	X	X			X	X
	Fast Bond 2000 Adhesive	X	X	X			X	X
Cookson America	E-Z Weld	X						
Daubert Chemical Co.	Daubond 6552	X	X		X	X	X	
	Daubond 8050	X	X		X	X	X	
	Daubond 8855	X	X			X	X	
	Unidex Solvent Epoxy	X	X					
Dow Corning Corp.	739 Plastic Adhesive	X	X	X	X			
	832	X	X					
GE Silicones	Silicone II Window and Door	X	X	X	X	X	X	
Henkel Loctite Corporation	Prism 454 Surface Insensitive Instant Gel	X	X			X	X	
	Speedbonder 324, 325, 326 (structural bond)	X	X					
Oatey Co.	PVC and ABS and CPVC All Purpose Cement	X	ABS, CPVC					
National Casein	PVC-E4HV	X						

Sashco	Lexel	X	X	X	X	X	X	
Satellite City	Hot Stuff™ Super T, Special T	X	X	cosmetic			X	
Schwartz Chemical Company	VC1, VC2	X						
	Rez-N-Glue 3926		X	X	X	X	X	
TEC Specialty Products, Inc.	Max Bond (reinforcing bond with mechanical fasteners)	X	X	X	X	X	X	

## Recommended Adhesive Manufacturers

Company	Telephone	Address
3M Adhesives Division www.3m.com/adhesives	800.362.3550 651.733.1110 Fax 651.733.9973	3M Center Building 220-8E-05 St. Paul, MN 55144-1000
Cookson America	800.327.8460	1661 Old Dixie Highway Riviera Beach, FL 33404
Daubert Chemical Co. www.daubertchemical.com	800.688.0459 Fax 708.496.7367	4700 S. Central Avenue Chicago, IL 60638
Dow Corning Corporation www.dowcorning.com	800.248.2481 989.496.6000 Fax 989.496.6974	Product Information Dept. PO Box 994 Midland, MI 48686-0994
GE Silicones Inc. www.gesilicones.com	800.255.8886 877.943.7325 Fax 518.233.3529	260 Hudson River Road Waterford, NY 12188
Henkel Loctite Corporation www.loctite.com	800.562.8483 860.571.5100 Fax 860.571.5465	1001 Trout Brook Crossing PO Box 4016 Rocky Hill, CT 06067
National Casein www.nationalcasein.com	773.846.7300 Fax 773.487.5709	601 West 80th St. Chicago, IL 60620
Oatey Company www.oatey.com	800.321.9532 216.267.7100 Fax 216.267.6538	4700 West 160th Street Cleveland, OH 44135
Sashco www.sashco.com	800.289.7290 Fax 303.286.0400	10300 107 <sup>th</sup> Place Brighton, CO
Satellite City www.caglue.com	805.522.0062 Fax 805.572.9114	PO Box 836 Simi Valley, CA 93062
Schwartz Chemical Company	718.784.7592	50-01 Second St. Long Island City, NY 11101

## Additional Adhesive Manufacturers

Company	Telephone	Address
Bostik Findley, Inc. www.bostik.com	800.726.7845 978.777.0100	211 Boston St. Middleton, MA 01949-2128
Henkel Adhesives www.henkeladhesives.com	847.608.0200 Fax 847.608.0212	1345 Gasket Dr. Elgin, IL 60120
IPS www.ipscorp.com	800.421.2677 310.898.3300	455 W. Victoria Street Compton, CA 90220
Liquid Nails (a division of ICI Paints) www.liquidnails.com	800.634.0015	925 Euclid Ave. Cleveland, OH 44115
Parabond www.parabond.com	800.742.1431	600 Ellis Rd. Durham, NC 27703
TACC (a division of Illinois Tool Works) www.taccint.com	800.503.6991 516.623.6000 Fax 516.867.1060	Air Station Industrial Park Rockland, MA 02370

## Additional Manufacturers of Adhesives Specific to Celtec 550

Company	Telephone	Address
AmBel Corporation www.excelglue.com	800.779.3935 318.876.2495 Fax 318.876.2213	P. O. Box 819 188 Cottonport Ave. Cottonport, LA 71327
OSI Sealants, Inc. www.osisealants.com	800.321.3578 Fax 800.227.6095	7405 Production Dr. Mentor, OH 44060
Siroflex, Inc. www.siroflexinc.com	800.359.6398 864.458.9094 Fax 864.458.9092	1320 Garlington Rd. Greenville, SC 29615
White Lightning (a division of Diversified Brands) www.diversifiedbrands.com	800.777.2966 Fax 800.243.3075	101 Prospect Ave. Cleveland, OH 44115

[This page intentionally left blank.]

# Forming/Welding

# 3

---

Celtec® can easily be shaped using conventional methods, such as heat bending, pressure forming and vacuum forming. Because Celtec heats and cools very quickly, the formed parts are cleanly and clearly defined, making the material excellent for sign faces and point-of-purchase displays.

## Heat Bending

Celtec sheet material can be bent by using Calrods, radiant heaters, strip heaters (Figure 3a) or air-circulated ovens. Heat guns can also be used on small areas. To ensure best results, a rheostat should be used to control heating of the Celtec so that the surface temperature does not exceed 340°F.

### NOTE!

Heating Celtec material over 340°F can cause the surface to become rough and possibly discolor.

When using a metal contact strip heater, cover the heater strip with Teflon spray to prevent marking the Celtec. Different sizes of rectangular heating bars can be used to produce bends of different radii. The larger the heated area of the Celtec, the larger the radius that can be created.

Celtec should be heated from both sides when the sheet is thicker than 4 mm. Celtec heats much more quickly than solid PVCs or acrylics and requires heating at the rate of approximately 30 to 40 seconds per millimeter of thickness prior to bending.

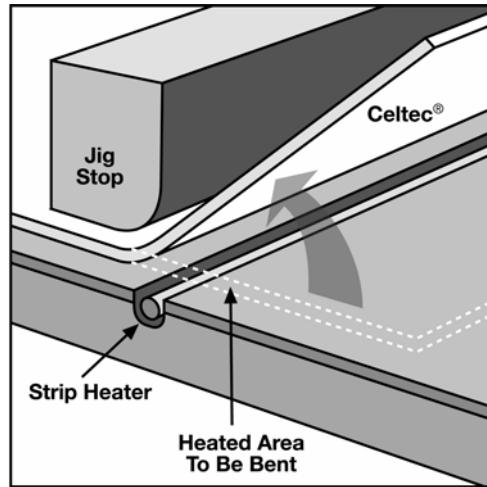

◀ **Figure 3a:**  
Heat bending using a strip heater and a jig.

To form tighter bends with smaller radii, use a small heated area on the upper surface (inside the bend) of the Celtec sheet and a larger heated area on the bottom surface (on the outside of the bend) of the sheet. A minimum radius of twice the sheet thickness is necessary to avoid breakage (Figure 3b). When bending Celtec into an angle, typically the extension of the Celtec on either side of the angle should be at least 20 times the thickness of the Celtec material. For example, 6 mm (1/4") Celtec would require the extension on each side to be 120 mm (4-3/4") in order to avoid warping of the material. For sides less than 20 times the material's thickness, the entire sheet must be heated.

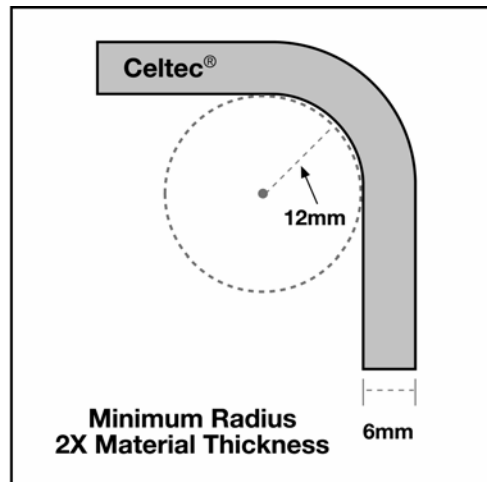

◀ **Figure 3b:**  
Minimum recommended radius of two times the Celtec sheet thickness.

Once the Celtec is bent, place it in a fixture, such as a jig or clamp, to cool. Fans and/or compressed air will speed the cooling process.

## Pressure or Drape Forming

Celtec can be heated using radiant heat panels or air circulating ovens. Either male or female molds can be coupled with plug assists or forced air to form parts (Figure 3c). This procedure is recommended for simple shallow forms with low definition. Conventional equipment used for other thermoplastics is also ideally suited for Celtec.

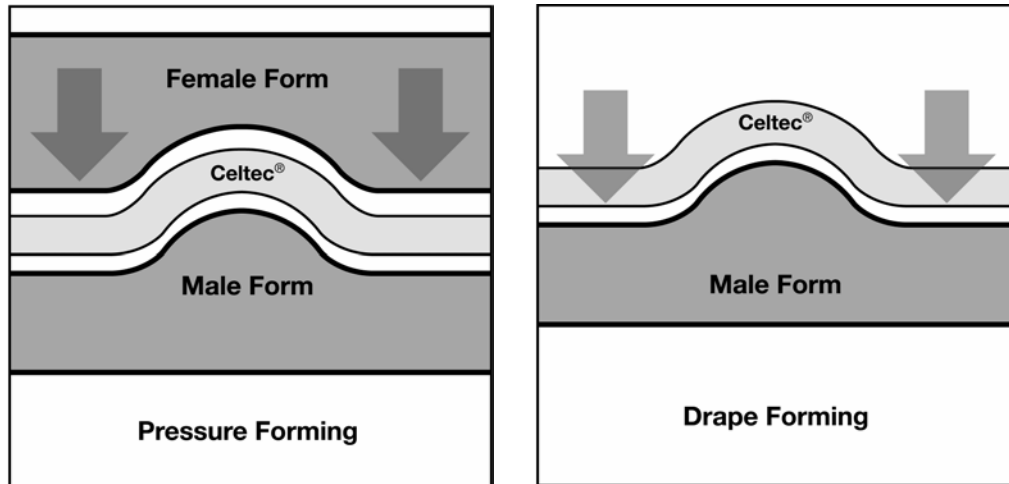

▲ **Figure 3c:**

Conventional pressure forming, accomplished with a two-piece mold, and drape forming.

**NOTE!**

When using radiant heaters, be careful not to overheat the surface.

If the Celtec material is over 4 mm thick, both sides of the sheet should be heated (Figure 3d). When heating from only one side, the top heater should be set at 750°F or below. With two-sided heating, the top heater should be at 750°F and the bottom at 650°F. If using an air-circulated oven, the temperature should be between 260°F and 280°F.



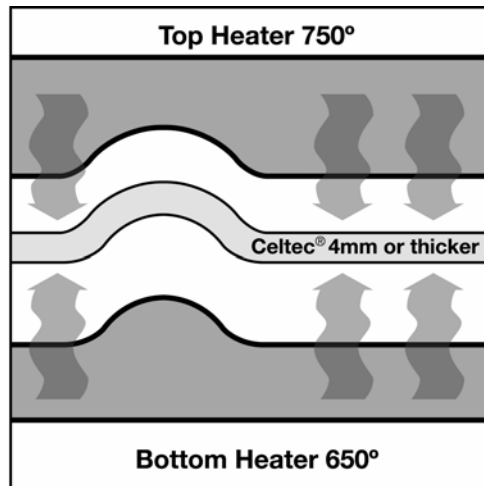

◀ **Figure 3d:**  
Heating Celtec.

After the Celtec is heated, place it immediately into the mold. The male mold should have a draft angle of at least 5 degrees. Depending upon the part to be formed, the Celtec material may need to be larger than the mold to allow for shrinkage and/or clamping.

Because there are limits to the Celtec material's ability to stretch while still producing aesthetically acceptable results, the depth of the part that can be successfully created will depend upon both the mold and the part's design.

**NOTE!**

When creating or selecting a mold for Celtec material, it is important to use a mold without sharp corners.

Cycle times for Celtec are very fast, approximately 15 to 20 seconds per millimeter of thickness with radiant heaters and 30 to 40 seconds per millimeter in air circulating ovens.

## Vacuum Forming

Vacuum forming of Celtec is similar to pressure forming except that it is generally used when greater part detail and dimensional repeatability are necessary (Figure 3e). The forming temperature for Celtec is also higher, generally 330°F to 340°F. Exceeding 340°F is not recommended because it can cause bubbling of the Celtec surface.

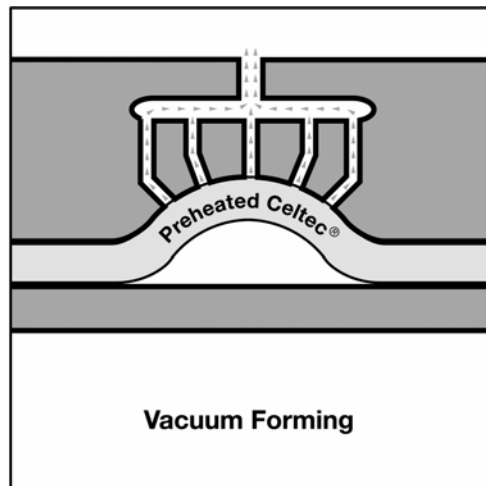

◀ **Figure 3e:**  
Vacuum forming.

Molds for vacuum forming are generally made of wood or plaster for short life short runs and of nonferrous metals for long life long runs. For metals, aluminum is generally the material of choice. Molds should be designed with radii at least two times the material thickness and draft angles of  $5^\circ$  or greater. Vacuum holes should not exceed  $1/32''$  in diameter.

Since the Celtec sheet may shrink in the extrusion direction, it is necessary to use a clamping ring, preferably with anti-slip devices. The Celtec material must be cooled completely before it is removed from the mold.

## Heat Welding

Celtec can be joined using fusion welding, ultrasonic welding and hot gas welding.

For Celtec thicknesses over 6 mm, butt fusion welding is recommended. In general, the pressure used for solid PVC must be reduced for expanded PVC. Exact recommendations are dependent on the length and thickness of the Celtec part to be welded. For more precise information, contact Wegener North America. Ultrasonic welding of Celtec is currently in the development stages. For more information contact Edison Welding Institute. Contact information can be found at the end of this chapter.

Hot gas welding can be performed with a hot air gun and welding rod (Figure 3f). The air should be clean and free of all contaminants. If the air is not clean, an inert gas such as nitrogen can be used. The welding temperature and volume of air should be adjustable. Celtec welds ideally with a Type II welding rod but also can be welded with a Type I welding rod. The weld strength is approximately 60% of solid PVC.

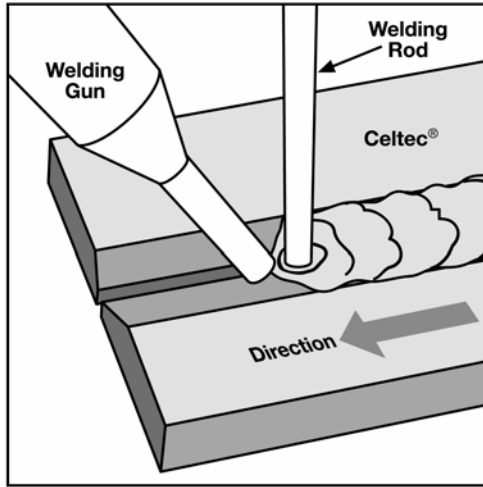

◀ **Figure 3f:**  
Heat welding of Celtec.

The Celtec sheets to be welded should be free from dust or oil. For butt welding using the hot gas method, sheets should be chamfered using a table saw, milling machine or router. The angle should be  $60^\circ$  for round beads and  $80^\circ$  for triangle beads with corner welds at right angles (Figure 3g). The chamfer should be at  $45^\circ$ .

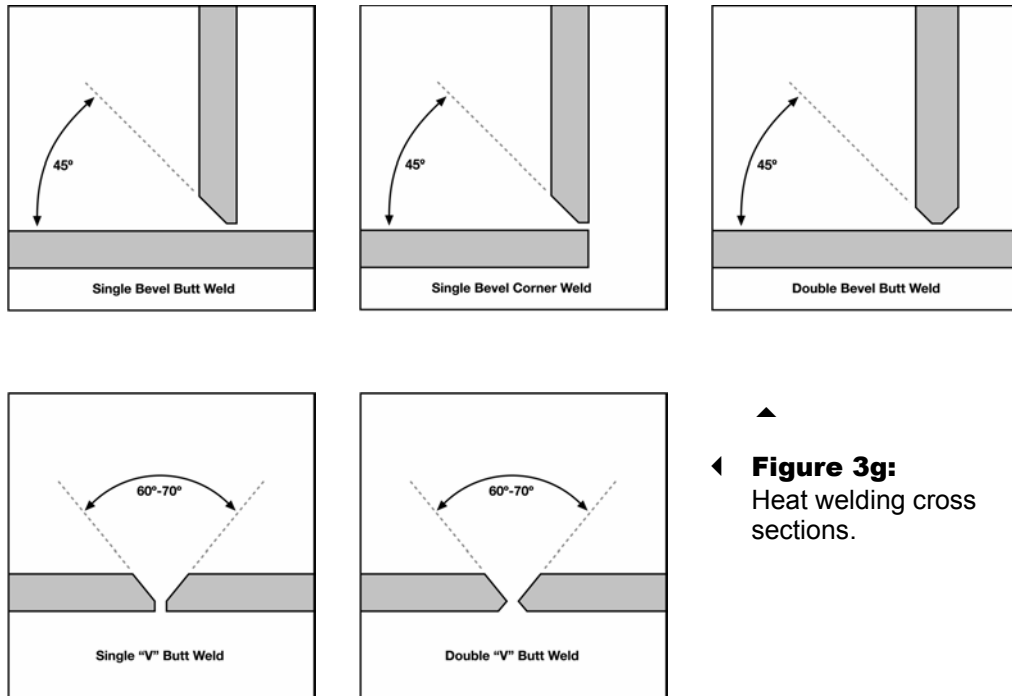

▲  
◀ **Figure 3g:**  
Heat welding cross sections.

To weld Celtec material, feed the rod through the gun and apply pressure on the rod as the sheet and rod are heated simultaneously. The temperature of the gas should be at 680°F when measured 3/16" inside the tip of the gun. The volume of air should be 50 liters per minute using a flow regulator with welding pressure at approximately 2 to 3-1/2 lbs., depending on the rod diameter. Following these guidelines, welding speeds between 11 to 20 inches per minute are possible.

**NOTE!**

Skiving off the weld joint for aesthetic purposes will reduce weld strength.

## Manufacturers

### Bending and Forming Equipment

Company	Telephone	Address
C.R. Clarke & Co., Inc. www.crclarke.co.uk	800.676.7133 407.566.0755 Fax 407.566.0756	1106 Celebration Avenue Kissimmee, FL 34747
Kamweld Technologies, Inc. www.kamweld.com	781.762.6922 Fax 781.762.0052	90 Access Road Norwood, MA 02062
Wegener North America www.wegener-na.com	630.789.0990 Fax 630.789.1380	16W231 S. Frontage Road, Unit 12 Burr Ridge, IL 60527

### Thermoforming Equipment

Company	Telephone	Address
Brown Machine LLC www.brown-machine.com	989.435.7741 Fax 989.435.2821	330 North Ross St. Beaverton MI 48612
Lamco Machine Tool Inc. www.lamcomachine.com	252.247.4360 Fax 252.247.4633	135 Industrial Drive Morehead City, NC 28557
MAAC Machinery Corporation www.maacmachinery.com	630.665.1700 Fax 630.665.7799	590 Tower Blvd. Carol Stream, IL 60188
Plasti-Vac, Inc. www.plastivac.com	800.438.4139 704.334.4728 Fax 704.334.0251	P. O. Box 5543 Charlotte, NC 28225

### Line Bending Equipment

Company	Telephone	Address
Big Chief Supply Company	513.271.7411 Fax 513.271.0790	5150 Big Chief Dr. Cincinnati, OH 45227
Craftics Inc. www.craftics.com	505.338.0005 Fax 800.289.2020	PO Box 91930 Albuquerque, NM 87199
FTM, Inc./Westedge www.123ftm.com	530.626.1986 Fax 530.642.2602	6160 Cobblestone Rd. Placerville, CA 95667
Watlow Electric Manufacturing Co. www.watlow.com	800.492.8569 314.878.4600	12001 Lackland Rd. St. Louis, MO 63146

## Welding Equipment

Company	Telephone	Address
Kamweld Technologies, Inc. www.kamweld.com	781.762.6922 Fax 781.762.0052	90 Access Road Norwood, MA 02062
Laramy Products Co., Inc. www.laramyplasticwelders.com	802.626.9328 Fax 802.626.5529	40 Sandy Lane Lyndonville, VT 05851
Seelye Inc. www.seelye-plastics.com	800.328.2728 612.881.2658 Fax 612.881.3503	9700 Newton Avenue South Bloomington, MN 55431
Wegener North America, Inc. www.wegenerwelding.com	630.789.0990 Fax 630.789.1380	16W 231 S. Frontage Road, Unit 12 Burr Ridge, IL 60527

## Ultrasonic Equipment

Company	Telephone	Address
Dukane Corporation www.dukane.com	630.584.2300 Fax 630.584.2370	2900 Dukane Dr. St. Charles, IL 60174

[This page intentionally left blank.]

# Graphic Applications

# 4

---

Celtec Displayboard performs outstandingly with a wide range of graphic applications including: paints, varnishes, screen printing, digital flatbed printers and vinyl films. Celtec can be used to create weather resistant signs, displays or Point of Purchase materials. The smooth Celtec surface is ideal for all types of graphics and it requires little surface preparation or surface treatment.

## General Considerations

To ensure best results for any graphic application using Celtec, consider the following factors that may affect the finished installation:

- Environmental and safety concerns
- Weathering
- Chemical resistance
- Ease of application
- Cost-effectiveness
- Hardness
- Scratch resistance
- Priming or multicoat paint applications

TIP ▶

Because of the wide range of products available, select paints and varnishes carefully for each application. Initial testing of the selected paint or varnish system is recommended before a production run.

## Cleaning / Pretreating

Before screen printing, painting or varnishing Celtec, the surface area should be cleaned with isopropyl alcohol and a clean white cloth. Depending on the specific application, certain pretreatments may also be required, as described in the following sections.



## Digital Flatbed Printing

Celtec provides an excellent surface for screen printing and accepts a wide range of inks. When silkscreening on Celtec, crisp, full coverage is achieved with printing inks that normally would be used for other rigid PVC products.

**TIP** ▶

Celtec Displayboard in the 10 mm thickness and above provides an extremely smooth surface for printing.

For best results when screen printing, be sure that the Celtec sheet has been degreased and cleaned with a lint-free cloth. Always use PVC screen inks and thinners from the same product line and manufacturer. Incompatibility of inks and thinners may cause surface cracking and reduce the life span of the Celtec material.

**NOTE!**

A sample of Celtec should be flood-screened prior to production to ensure a finished product of acceptable quality.

## Painting / Varnishing

Although Celtec requires no painting, any painting planned for a project should be completed as soon as possible, either during or soon after the construction process. Priming is not mandatory but should be performed prior to painting if the paint manufacturer's warranty is a consideration. In order to avoid heat buildup, light paint colors are recommended for most applications. Sheets of 19mm and greater thickness can accept slightly darker colors, but not very dark (i.e. black, brown, forest green, etc.).

Paint adheres to Celtec material exceptionally well. In general, no primers are needed to prepare the Celtec sheet for painting, although the surface of the Celtec should be dry, clean and degreased for best results. Any method of paint application may be used, including power or manual rollers, spray guns, conventional brushes, sponge-type brushes, artists' lettering brushes and/or dipping. Celtec sheets are painted most successfully with vinyl paints, non water-based acrylic lacquers, two-component polyurethanes and

other paints suitable for PVC. For best results, use a high quality, 100% acrylic paint.

One interesting development that has shown great benefits in painting for outdoor applications is the UV reflective paints available through Blue River Coatings and Reno Coatings. Test data shows that the surface temperatures are dramatically decreased which helps reduce expansion and protects the material for a longer lasting sign. These UV reflective coatings are especially beneficial when a darker color is needed for a sign or display. Care should be taken to follow the manufacturer's procedures and always test a small piece in the application before final preparations are made. See the Paint Manufacturers table and the addendum at the end of this chapter for contact information and test data.

**NOTE!**

Most enamels and water-based systems are generally not recommended for Celtec.

Conventional equipment may be used to apply varnish to Celtec. Before applying varnish, Celtec sheets should be wiped or treated with an antistatic solution or solvent wipe to ensure that the surface is clean and properly prepared. Be sure to follow the manufacturer's instructions for thinning concentrated forms of varnishes. Apply paint or varnish in only one direction if using a brush (Figure 4a). Celtec material generally requires only one coat of varnish.

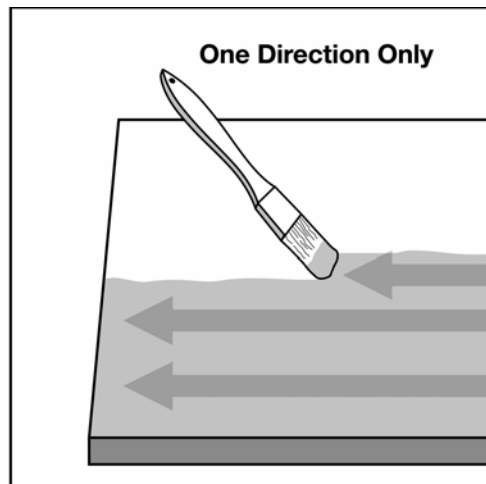
**◀ Figure 4a:**

To obtain optimum results for brush-applied paints and varnishes, apply coats in one direction and air dry according to manufacturer's instructions.

Celtec is a thermoplastic material that will deform at temperatures above 140°F and cannot thus be heat dried at high temperatures. Air dry paints and varnishes are therefore most successful with Celtec material. Most air dry varnishes dust-dry in 30 minutes at room temperature and are completely dry after 24 hours.

### Surface Preparation

Before painting or varnishing, clean the surface of the Celtec material with a clean cloth and an aliphatic solvent, such as isopropyl alcohol, heptane, octane, UM&P or naphtha, in order to produce good adhesion.

#### TIP ▶

Remove any scratches on the Celtec material's surface by sanding with fine sandpaper or by rapidly fanning the area with a heat gun. Once sanded, the original finish is removed.

### Cross Hatch Adhesion Test

Good paint and varnish adhesion is critical to achieving a successful finished product. The cross hatch adhesion test described below should be performed on every paint or varnish system unless it is specifically recommended for Celtec material. For paint and varnish brands, consult the list of recommended manufacturers at the end of this chapter.

#### NOTE!

Although most paints will feel dry to the touch after 24 hours, some paints may not acquire full adhesion to the Celtec material for two to three weeks after application.

1. On a sheet of Celtec, apply the paint or varnish to be tested for adhesion. Let dry for a minimum of 48 hours.
2. Using a knife with a replaceable blade, make 11 parallel cuts 1/16" apart. At a 90° angle to the first set of 11 cuts and crossing them, make a second set of 11 parallel cuts, also 1/16" apart (Figure 4b). The purpose of the cuts is to break the film plane of the paint or varnish.

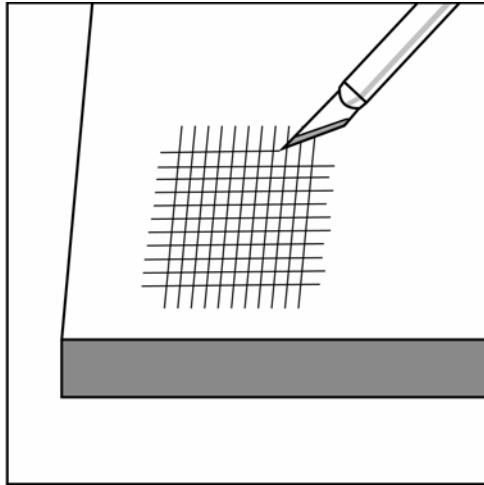

◀ **Figure 4b:**  
Make 11 parallel horizontal and parallel vertical cuts 1/16" apart.

3. Pressing firmly, apply a 1/2"-wide strip of strong tape (i.e. Scotch™ brand) across the scored area (Figure 4c).

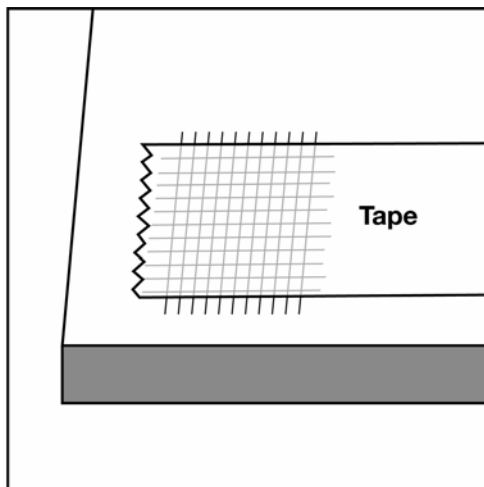

◀ **Figure 4c:**  
Place a 1/2"-wide strip of strong tape over the cross hatched area, aligning the edge of the tape with a cut line.

4. Immediately and in one rapid motion, remove the tape by pulling it back at a 180° angle, parallel to the Celtec sheet (Figure 4d).

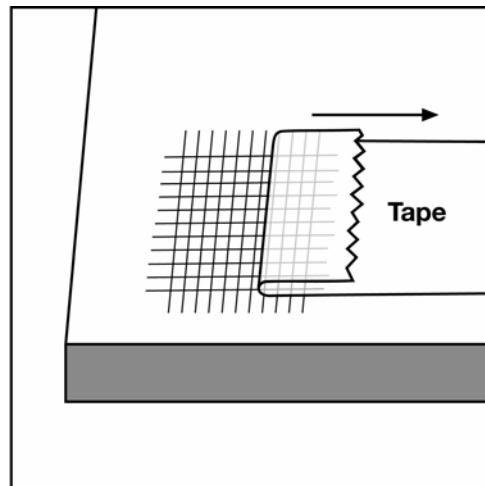

◀ **Figure 4d:** Remove the tape at a 180° angle in one rapid motion.

5. Proper adhesion has been obtained if paint remains on the Celtec after the tape is removed. Relative paint adhesion comparisons can also be made by inspecting the amount of paint remaining in the area that was covered by the tape.

### Application

Concentrated forms of paints and varnishes should be thinned before use. Follow the manufacturer's guide and recommendations.

For best results, conventional air spraying equipment can be used on Celtec material (Figure 4e). Paints and varnishes may also be applied with a paint brush or roller.

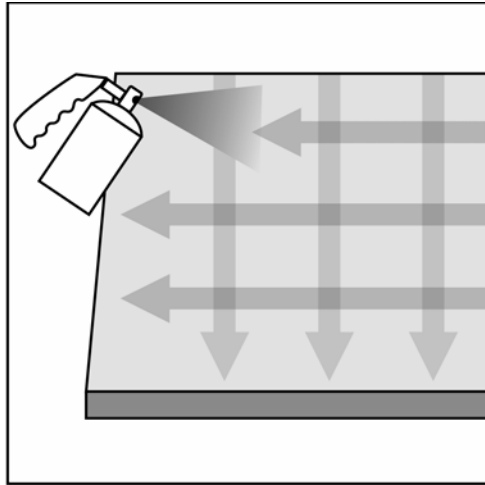

◀ **Figure 4e:**

When spray painting, complete all passes in one direction first, then make additional passes at 90° to the first.

### Spraying hints

- Do not use airless spraying equipment. Air-operated equipment, such as DeVilbiss spray finishers, is preferred.
- Use a spray nozzle with a #30 air cap to disperse the paint properly.
- Set the air pressure on the material at 24 psi and 40-50 psi on the air cap.
- Keep the spray gun nozzle perpendicular to the surface of the material.
- Make three spraying passes in one direction, turn the panel 90°, and make three additional passes.
- Lightly sand any runs that occur on the edges of the Celtec with 200 grit sandpaper and touch up with additional paint or varnish as needed.

## Vinyl Lettering

When applying text to Celtec, pressure-sensitive or static cling vinyl letters are highly recommended. As with other graphic applications, the surface of the Celtec material must be free of dust or other small particles, degreased and dry before applying lettering.

# Specifications

## Recommended Silkscreen Inks for Celtec

Manufacturer	Trade Name	Type	Mesh	Squeegee	Reducer
Coates Screen	C99	Vinyl	230	70 D	ET-10
	Series HG	Vinyl	305	55-65 D	HG-V
	Series UVN	UV Cure	305	75-85	Call Mfr.
NazDar	VP	Solvent-based	200-305	75-80	VP-180
	System-2	Solvent-based	200-305	-	S-230
	2700	Water	200-305	-	RE-192
	MP Multi Purpose	Solvent-based	200-305	-	MP-180
	9700	Solvent-based	200-305	75-80	RE-180
	1600	UV	355-390	70-90	RE-301
	1700	UV	355-390	70-90	RE-317
	3600	UV	355	70-90	RE-306
Sericol, Inc.	Uviflex	UV	390T LE Twill	70-90	UX-MX UX-TH
	Fascure	UV 4-color process	390T LE Twill 390T LE Plain	70-90	-
	GVYL	Vinyl	230	60 D	80236
	Plastical	UV	390	80 D	-
	VYL	Vinyl	230	60 D	37270

## Silkscreen Ink Manufacturers

Company	Telephone	Address
Coates Screen www.coates-screen.com	800.333.4657 630.513.5348 Fax 630.513.1655	2445 Production Drive St. Charles, IL 60174
NazDar www.nazdar.com	800.767.9942 913.442.1888 Fax 913.442.2296	8501 Hedge Lane Terrace Shawnee, KS 66227
Sericol, Inc. www.sericol.com	800.sericol (tech service) 913.342.4060 Fax 913.342.4761	1101 W. Cambridge Drive Kansas City, KS 66103

## Recommended Paints

Manufacturer	Trade Name	Type	Catalyst	Reducer	Primer	Thinner
BASF	Glasuret 21	Acrylic Urethane*	-	-	-	-
Blue River Coating	Hydroflex P-IR	Water Based Urethane	X7000	-	-	Clean Water
	High Perf. A-IR	Acrylic Urethane	X7000	-	-	Clean Water
Carbit Paint	Carbithane 11 Series Low VOC	Acrylic Polyurethane	11C2	T-64	-	-
	Carbithane 12 Series	Acrylic Polyurethane	12C0	T-64	-	-
Matthews	MAP	Acrylic Polyurethane	43-270SP 43-621SP**	45-280SP 45-290SP 6372SP 6396SP	Tie Bond 74 777SP	45-280SP 45-290SP 6372SP 6396SP
	Satin MAP	Acrylic Polyurethane	43-270SP 43-621SP**	45-280SP 45-290SP 6372SP 6396SP	Tie Bond 74 777SP	45-280SP 45-290SP 6372SP 6396SP
	VOC MAP	Acrylic Polyurethane	285-800SP	6300SP 6301SP 6302SP	Tie Bond 74 777SP	45-280SP 45-290SP 6372SP 6396SP
	Satin VOC MAP	Acrylic Polyurethane	285-320SP	6300SP 6301SP 6302SP	Tie Bond 74 777SP	45-280SP 45-290SP 6372SP 6396SP
One Shot	1 Shot Lettering	Enamel	-	-	-	-
RenoCoatings	Prolux Series 32000	-	-	-	-	-
Samuel Cabot	The Finish, 1700 Series	Acrylic, low-lustre exterior	-	-	-	-
Sherwin Williams	Polane E	5.0 VOC High Gloss Flexible Polyurethane Enamel, Exterior***	V66V29	R7K338	-	-
	Polane HS Plus	2.8 VOC High Gloss Polyurethane Enamel, Exterior	V66V55	R7K30	-	-
	Polane S Plus	2.8 VOC Low Gloss Polyurethane Enamel, Exterior	V66V55	R7K30	-	-
	Polane T 60	2.8 VOC Low Gloss Polyurethane Enamel, Interior	V66V90	R7K84	-	-
Spraylat	Lacryl 400	Acrylic Lacquer	-	-	-	205-T 206-T
	Lacryl 800	Acrylic Lacquer	-	-	-	205-T 206-T 208-T



	Polycryl 7000	Acrylic Lacquer	-	-	-	-
T. J. Ronan	Bulletin Color	Alkyd Enamel	-	-	Prime-All	-
	Aqua Cote	Waterborne Acrylic	-	-	Prime-All	-

\*Requires the use of 521-111 Elastiger Plus Topcoat.

\*\*Requires the use of 47-444SP Brushing-Rolling Additive.

\*\*\*Requires R7KB4 solvent needed.

## Paint Manufacturers

Company	Telephone	Address
Akzo Nobel Coatings Inc. www.azkonobel.com	770.662.8464 Fax 770.662.5936	5555 Spalding Dr. Norcross, GA 30092
BASF Corporation www.basf.com	973.426.2600 Fax 973.426.2610	3000 Continental Drive-North Mount Olive, NJ 07828-1234
Blue River Coatings www.bluerivercoatings.com	888.420.2628 Fax 336.812.9036	2910 South Nebraska Ave. Hastings, NE 68901
Carbit Paint Company www.carbit.com	800.288.2320 312.280.2300 Fax 312.280.7326	927 West Blackhawk St. Chicago, IL 60622-2519
Hydrocote Finishing Products, Inc. www.hydrocote.com	800.229.4937 732.828.7448 Fax 732.828.7325	61 Berry St. Somerset, NJ 08873
Matthews Paint Company www.signpaint.com	800.323.6593 262.947.0700 Fax 262.947.0444	LakeView Corporate Park 8201 100 <sup>th</sup> Street Pleasant Prairie, WI 53158
One Shot, LLC (a subsidiary of Spraylat Corporation) www.1shot.com	219.949.1684 Fax 219.949.1612	5300 West 5 <sup>th</sup> Ave. Gary, IN 46406
PPG, Inc. www.ppg.com	412.434.3131	One PPG Place Pittsburgh, PA 15272
Reno Coatings, Inc. www.renocoatings.com	450.621.7746	485 De L'Érablière Rosemere, P.Q., Canada J7A 4M4
Samuel Cabot Paint www.cabotstain.com	800.878.8246	See website for local distributor
Schwartz Chemical Company	718.784.7592	50-01 Second St. Long Island City, NY 11101
Sherwin Williams Company www.sherwinwilliams.com	800.336.1110	Contact local dealers
Spraylat Corporation www.spraylat.com	914.699.3030 Fax 914.699.3035	716 S. Columbus Avenue Mt Vernon, NY 10550

## Manufacturers

### Primer Manufacturers

Company	Telephone	Address
Masterchem Industries www.masterchem.com	800.325.3552 866.Primer1 Fax 636.942.3663	3135 Highway M Imperial, MO 63052
One Shot, LLC (a subsidiary of Spraylat Corporation) www.1shot.com	219.949.1684 Fax 219.949.1612	5300 West 5 <sup>th</sup> Ave. Gary, IN 46406
T. J. Ronan Paint Company www.ronanpaint.com	800.247.6626 718.292.1100 Fax 718.292.0406	749 East 135 <sup>th</sup> St. New York, NY 10454

### Vinyl Graphics Manufacturers

Company	Telephone	Address
3M Commercial Graphics Division www.scotchprint.com	800.328.3908 Fax 651.736.4233	3M Center Building 220 6W-06 St. Paul, MN 55144
Arlon www.arlon.com	714.540.2811 Fax 714.540.7190	2811 S. Harbor Blvd. Santa Ana, CA
Kapco Graphics www.kapcographics.com	330.678.1626 Fax 330.678.3922	1000 Cherry St. Kent, OH 44240
ORACAL USA www.oracal.com	904.726.9597 Fax 904.726.9409	7251 Salisbury Rd. Jacksonville, FL 32256

## Addendum

### Test Data for Reno Coatings Prolux Series 32000

Three pieces of 1-1/2" Celtec Displayboard Foam PVC were cleaned and coated with Prolux Series 32000 brown paint. After 30 minutes of air-drying, the pieces underwent two hours of forced drying at 110°F.

After 10 days the three samples were tested for adhesion and showed complete adhesion of the paint to the substrate.

The pieces were also tested for resistance to heat buildup, using a 250-watt infrared lamp. The samples were placed under the lamp, with the painted surface facing the lamp at a distance of 13 inches. After one hour, the maximum temperature reached by the surface was 160°F (hottest spot) measured with an IR gun. The three samples performed very well, with no change or deterioration at the surface, no blistering of the paint and no deformation of the substrate.

A similar high-quality brown paint (but with no heat-reflective properties) was applied to the other side of the samples. Upon performing the same heat exposure test, the hottest spot reached 230°F, and there was a slight deformation of the surface at that area.

# Special Applications

# 5

---

Celtec's light weight, strength and versatility allow it to be used in many special applications. Celtec is an effective core material for panel constructions using common synthetic resins or a wide variety of structural adhesives or plastics. Celtec's smooth surface and adherence capacity make it an excellent choice for photomounting and laminating, whether by hand for small jobs or with automated equipment for larger production runs.

## Photomounting

Celtec offers an excellent surface for mounting numerous materials, including Cibachrome prints, lithographs, blueprints, tissues and nearly all types of other papers (Figure 5a). Because of its strength and rigidity, a stronger finished product is produced using Celtec as compared to other available substrate materials. For example, the corners of a Celtec photomounting application will not bend or crease, as will items mounted on cardboard or foam-type materials.

One significant advantage for photomounting is Celtec's smooth finish relative to other thermoplastics. This finish allows prints to be easily repositioned or other mounted materials to be removed when necessary.

Once the mounting process is complete, Celtec can be laminated and then routed, heat bent, drilled, silk screened or painted for use in virtually any display application.

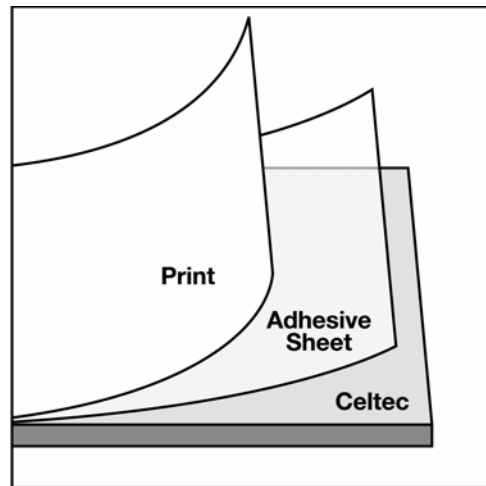

◀ **Figure 5a:**  
Mounting a print to Celtec using  
a sheet adhesive.

The preferred methods of photomounting on Celtec sheets are:

- cold mounting using cold roller laminators, such as Warman-Greig, Greig or Sealeze presses;
- cold vacuum mounting with VacuSEAL presses; and
- hand lamination.

The sophisticated Greig press is used by large photo labs, while the Sealeze press is more commonly found at small commercial labs. The VacuSEAL press is utilized primarily by photo shops.

**NOTE!**

Because Celtec material may warp when heated above 140°F or when heated from one side only, it cannot be dry mounted or hot mounted.

## Laminating

Celtec is an ideal material for applications that require lamination. This section provides preparation information processes as well as detailed instructions for the various types of lamination that can be used with Celtec.

Because prints are one of the most frequently laminated materials, the sections that follow will generally refer to the lamination of a print, although many other materials can be used.

**NOTE!**

Because Celtec material may warp when heated above 140°F or when heated from one side only, it cannot be used in any lamination process requiring heat.

**Adhesion**

For best results, the Celtec material should be cleaned with isopropyl alcohol prior to adhesion and allowed to dry thoroughly

When laminating with pressure-sensitive adhesives, a force of 25–40 psi is required (Figure 5b). Proper spacers are also critical. Because force must be applied equally across the material, the top roll must move evenly from left to right while maintaining even contact between top and bottom laminating rolls. To achieve even contact, “zero the nip,” then use spacer shims to preset the nip opening for a particular laminate. Use sufficient pressure to completely eliminate any air bubbles between the Celtec material, the adhesive and the print or other material.

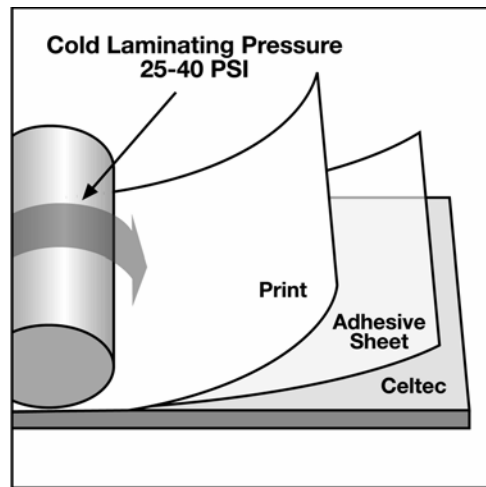

◀ **Figure 5b:**

To use cold lamination with a pressure sensitive adhesive, a force of 25-40 psi is required.

The lamination will achieve maximum bonding in three hours. If the lamination has been performed properly, the finished mount can be flexed without the print becoming loose in the center.

To prevent moisture from becoming trapped between layers of porous material (such as paper) and creating blisters, the level of moisture in both the material to be laminated and the atmosphere should be reduced before pressing. Some materials may require predrying. Celtec is nonporous and does not need predrying.

**NOTE!**

Avoid hanging tacked pieces upside down for longer than 10 minutes as the prints may absorb moisture and change in dimension, causing bubbles and wrinkles in the finished product.

### Preventing Surface Blemishes

Surface blemishes, such as wrinkles, can be caused by misalignment of the adhesive roll, too much pressure or rollers that are not parallel. Trapped dirt or lumps of hardened adhesive common with Cibachrome or glossy prints may create small bumps in the finished product.

In order to prevent these problems, equipment used for Celtec lamination must be kept clean (Figure 5c). Use a fresh roll or sheet of transfer adhesive if bumps are caused by hardened adhesive. Dirt problems can be minimized by using an ionizing static eliminator.

Using prints or other materials made with a paper 0.007" or thicker can help prevent strike through.

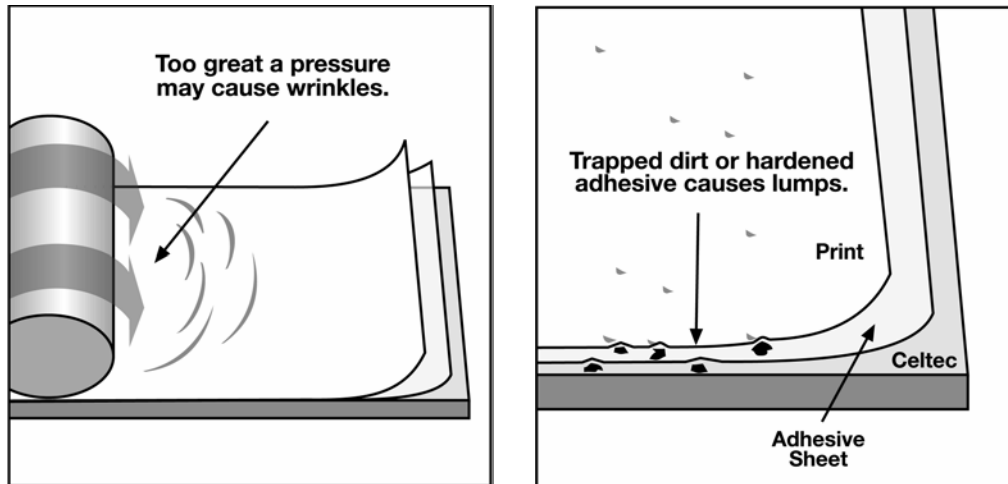

▲ **Figure 5c:**

To prevent surface blemishes and wrinkles, keep equipment clean.



**TIP** ▶

For best results, wipe down the back of the print and the face of the Celtec mount with a clean, dry cloth before it passes through the roll nip.

Whether the finished product is to be used indoors or outdoors, a clear, high gloss overlay will help protect against fading as well as enhance the color. MACtac IP 7000 Perma Color overlay and Seal Print Shield have proven to work effectively with Celtec.

**NOTE!**

Do not use overlays, clear coatings or sprays that contain solvents, as they may cause blistering.

## Laminating Techniques

Four techniques are recommended for laminating materials to Celtec, as described in the following sections. Depending upon the type of applications and the equipment available, one or more of these processes may be appropriate for a particular application.

None of these processes involves the use of heat. Because Celtec may warp at temperatures above 140°F or when heated from one side only, it cannot be dry mounted or hot mounted.

The four recommended lamination techniques for Celtec are:

- Cold laminating with a press using adhesive-backed paper
- Cold laminating using Vac-U-Mount press
- Hand laminating using transfer adhesive
- Hand laminating using spray adhesive

### **Cold Laminating with a Press using Adhesive-backed Paper**

This process is most frequently used by commercial photo labs with Greig or Sealeze presses and transfer adhesives, such as MACtac IP 2000, Photomount or Seal Print Mount.

Either of two types of liner films, a single release liner film or a double release liner film, can be used for this process. The basic process for laminating with a press using adhesive-backed paper is described in the following section.

1. Set the roller pressure properly for the thickness of the pre-coated mounting substrate.
2. Place the mounting substrate on a flat surface and expose approximately one inch of the adhesive by peeling back the release paper (Figure 5d). Fold back the release paper, making an even crease across the paper.

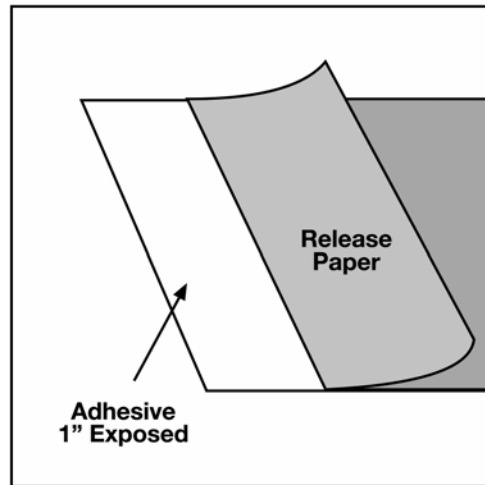

◀ **Figure 5d:**

Expose approximately 1" of the adhesive. Fold back the release paper in an even crease.

3. Carefully position the print on top of the substrate, using the folded release paper to prevent contact with the exposed adhesive (Figure 5e). Once positioned correctly, carefully apply the print to the exposed adhesive, pressing from the center toward the edges to ensure a smooth tack.

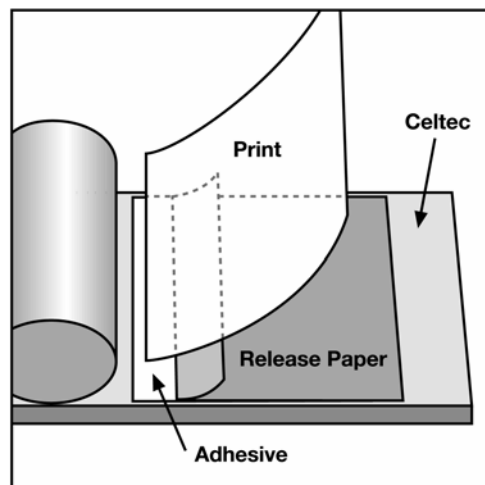

◀ **Figure 5e:**

Carefully position the print and apply the print to the exposed adhesive strip.

4. Place the direction switch in the forward position and the speed control on medium.
5. Insert the materials to be processed into the laminator opening. Depress the foot switch and feed the substrate between the rollers until the pressure roller rests on the tacked portion of the material.
6. Hold the untacked portion of the print up and against the pressure roller. Depress the foot switch to feed the substrate through the rollers while peeling the release paper off the mounting substrate with one hand. To prevent wrinkles, the print must be held against the roller with the opposite hand while the substrate feeds through the press.
7. Remove the mounted print from the rear of the laminator and trim it to the required size.

### ***Coating using Single Release Liner Films***

1. Set the pressure properly for the thickness of the substrate(s) to be processed.
2. Load the supply roll of pressure-sensitive adhesive, such as Sealeze Print Mount or Print Mount Ultra.
3. Pull approximately 12 inches of adhesive film forward off the roll. Rest the film, adhesive side up, on top of the pressure roller.
4. Create a leader board by cutting a piece of substrate slightly larger than the width of the adhesive film and approximately four to six inches long. Lay the leader board across the adhesive film and smoothly adhere the bottom of the leader to the adhesive.
5. Place the direction switch in the forward position and the speed control on medium.
6. Pull the leader down and push it between the rollers. Depress the foot switch and feed the leader between the rollers approximately three to four inches. Be sure that the adhesive stays firmly adhered to the leader.
7. Once this process has been completed (referred to as “stringing the web”) and the adhesive is feeding without wrinkles, the laminator is ready for production.
8. To coat, feed a substrate behind the leader board and between the rollers while depressing the foot switch. Feed until the substrate exits the rollers and automatically stops feeding. At this time, another substrate may be fed between the rollers for coating. This process is suitable for films with a paper release liner, such as Sealeze Print Mount and Print Mount Ultra and leaves a 3/8” to 1/2” gap between the coated substrates to facilitate the trimming process.

9. After exiting the laminator, the coated substrates should be split apart and trimmed (Figure 5f).

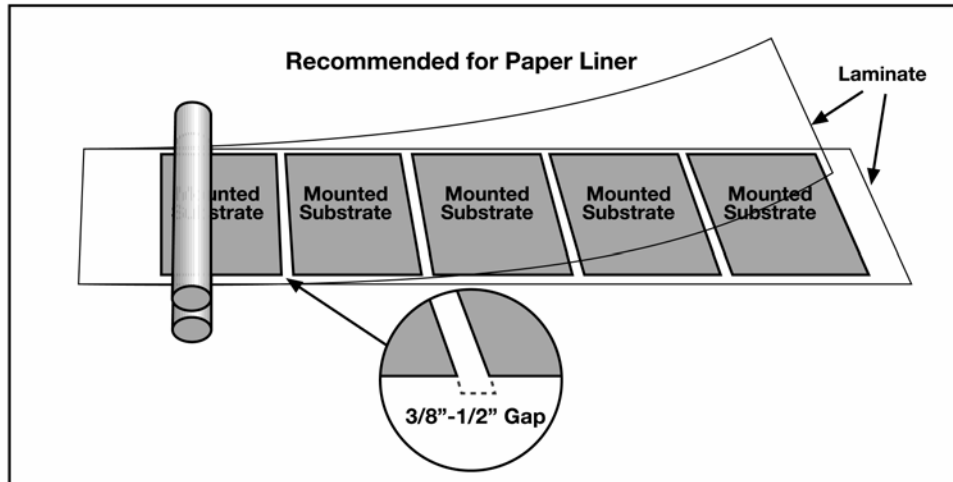

▲ **Figure 5f:**

After lamination, the coated substrate may be split apart and further trimming may be accomplished.

### ***Coating using Double Release Liner Films***

Coating with double release liner film, such as Sealeze OptiMount-UV or Print Mount Double, requires the use of a take-up mechanism to automatically remove and rewind one of the release liners during the coating procedure.

1. Set the pressure properly for the thickness of the substrates to be processed.
2. Load the supply roll of pressure-sensitive adhesive, such as Sealeze OptiMount-UV and Print Mount Double.
3. Adhere double-stick tape or a pressure-sensitive adhesive film, such as Sealeze Print Mount or Print Mount Ultra, to the surface of the take-up shaft.
4. Pull approximately 18 inches of adhesive film forward off the roll and adhere one release liner side smoothly to the take-up shaft, taking care to ensure that the film is square with the supply roll and no diagonal wrinkles are apparent (Figure 5g).

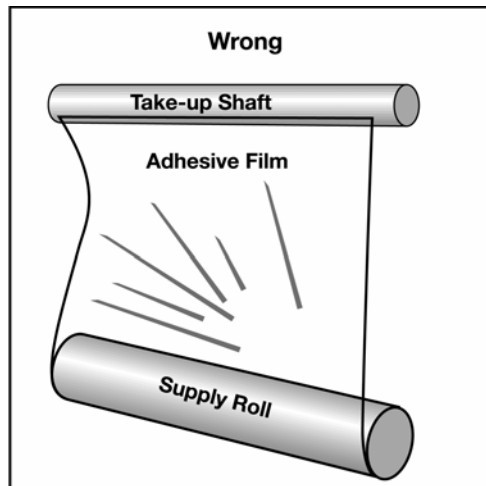

◀ **Figure 5g:**

Care must be taken to ensure film is squared to the supply roll or diagonal wrinkles will result.

5. Separate the adhesive film from the release liner secured to the take-up shaft and pull the adhesive film and remaining release liner down so that it rests adhesive side up on top of the pressure roller.
6. Lay a leader board the same thickness as the substrates to be used across the exposed adhesive film and smoothly adhere the bottom of the leader to the adhesive.

### Cold Laminating with VacuSEAL Press

This method is suggested for small and medium-sized photo shops for mounting prints utilizing a spray adhesive, such as 3M Vac-U-Mount.

1. Spray the adhesive, such as Vac-U-Mount, on the back of the piece to be mounted, keeping the spray six to eight inches from the surface. If using a double coat of adhesive, the second coat should be applied in a direction perpendicular to the first coat. For bonding most art materials, the adhesive is typically applied only to one surface, usually the back of the print.
2. Allow the spray to dry two to four minutes before mounting so that the adhesive becomes tacky. If blisters occur from trapped solvent, allow the adhesive to dry slightly longer than four minutes.
3. Position the print on the Celtec material and place inside the VacuSEAL vacuum frame.
4. Apply vacuum for 10 minutes.

## Hand Laminating using Transfer Adhesive

For small shops or display makers without access to presses, this method can be used for the lamination of flat, relatively small items utilizing a transfer adhesive (Figure 5h).

1. Using a sheet of transfer adhesive having both sides covered by release paper, peel away and fold back the release paper 1/2" inch from one edge.
2. Place the edge of the print to be laminated on the exposed adhesive.
3. Remove the rest of the release paper while lifting the print slightly to avoid contact with the adhesive, then use a roller or a squeegee to smooth the print evenly onto the adhesive.

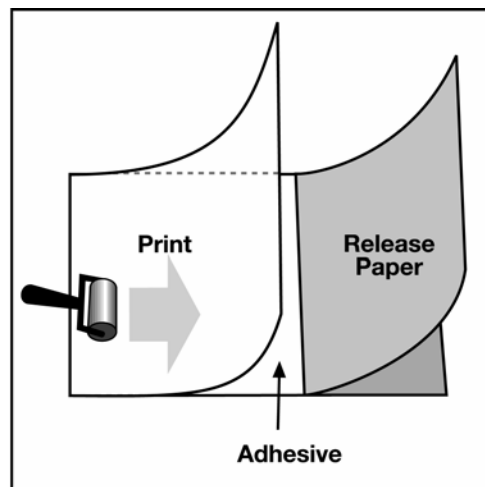

◀ **Figure 5h:**

This cross section illustrates cold laminating by hand, using transfer adhesive sheets with release paper.

4. With the print facing down and the remaining release paper facing up, smooth out any excess air from between the print and the adhesive with a squeegee.
5. To laminate the print to the Celtec material, peel away and fold back the release paper 1/2" inch from one edge.
6. Placing the print evenly on the Celtec material, tack the exposed adhesive to the Celtec.
7. Gradually remove the liner while pressing closely with a hand roller or a squeegee to eliminate any air bubbles until the entire print has been laminated (Figure 5i).

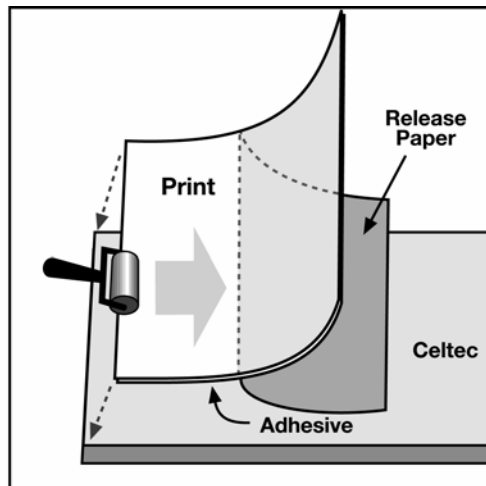

◀ **Figure 5i:**  
Press the print firmly with a hand roller or a squeegee while rolling in the same direction.

**TIP** ▶

For best results, remove only a small section of the liner at a time, approximately 12" or less, while adhering the print to the Celtec.

### Hand Laminating using Spray Adhesive

For small shops or display makers without access to equipment, this method is recommended for the lamination of flat, relatively small items utilizing a spray adhesive, such as 3M Vac-U-Mount (Figure 5j).

1. Spray the adhesive, such as Vac-U-Mount, on the back of the piece to be mounted, keeping the spray six to eight inches from the surface. If using a double coat of adhesive, the second coat should be applied in a direction perpendicular to the first coat. For bonding most art materials, the adhesive is typically applied only to one surface, preferably the back of the print.

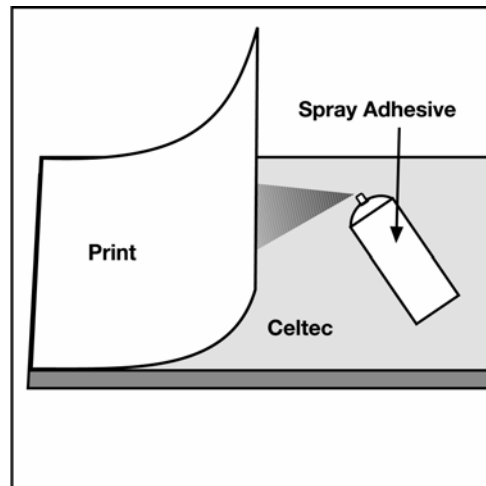

◀ **Figure 5j:**  
Mounting a print to Celtec using a spray adhesive.

2. Allow the spray to dry between two to four minutes before mounting so that the adhesive becomes tacky.
3. Place the adhesive side of the print or other item on the Celtec surface, pressing smoothly from the center of the piece to the edges in order to eliminate any wrinkles and trapped air immediately.

**TIP** ▶

If blisters occur from trapped solvent, allow the adhesive to dry slightly longer than four minutes for mounting.

4. Place a clean sheet of Celtec over the laminated piece to weigh it down. Although the bond should be at maximum strength after fifteen minutes, allow 24 hours before exposing the piece to any sudden temperature or humidity changes.

### Delaminating

A print mount can be delaminated within five minutes if a pressure-sensitive adhesive, such as MACtac IP 2000 or Seal Print Mount, has been used. Although the print is usually ruined, the Celtec material can be reused.

If five minutes have already passed, a hot air gun or a hair dryer can be used to heat the material in order to peel off the lamination. Isopropyl alcohol or mineral spirits can be used to remove the remaining adhesive.



## Manufacturers

### Photomounting Adhesive Manufacturers

Company	Telephone	Address
3M Adhesives Division www.3m.com/adhesives	800.362.3550 651.733.1110 Fax 651.733.9973	3M Center Building 220-8E-05 St. Paul, MN 55144-1000
DryTac Corporation www.drytac.com	800.280.6013 804.226.3094 Fax 804.226.2330	5383 Glen Alden Drive Richmond, VA 23231
Henkel Adhesives www.henkeladhesives.com	847.468.0200 Fax 847.608.0212	1345 Gasket Drive Elgin, IL 60120
MACtac www.mactac.com	330.689.8456 Fax 330.689.9841	4560 Darrow Road Stow, OH 44224

### Photomounting Press Manufacturers

Company	Telephone	Address
Advanced Greig Laminators www.aglaminators.com	608.846.1025 Fax 608.846.1024	801 Burton Boulevard DeForest, WI 53532
Robert L. Greig Company	800.525.2701	P. O. Box 419 Stoughton, WI 53589
Seal Graphics America www.sealgraphics.com	410.379.5400 Fax 410.579.8960	7091 Troy Hill Drive Elkridge, MD 21075

### Cold Mount Laminator Manufacturers

Company	Telephone	Address
Coda Inc. www.codamount.com	201.825.7400 Fax 201.825.8133	30 Industrial Avenue Mahway, NJ 07430

[This page intentionally left blank.]

# Engineering Specifications

# 6

---

Field performance of Celtec indicates excellent weatherability in outdoor applications under various environmental conditions. Tests are currently being conducted to accurately determine the long-term environmental effects of Celtec.

## **Weatherability / Effects of Outdoor Exposure**

### **Tensile Strength**

Virtually no tensile strength changes have been noted in prolonged environmental exposure tests.

### **Color**

**Dark colors are not recommended because they absorb heat energy and can exceed use temperatures.**

### **UV Stability of White Celtec**

One of the many advantages of Celtec expanded PVC sheet is its ultraviolet durability. Celtec is made with the same ingredients found in most weatherable vinyl siding and window materials. While the concentration of these ingredients is not the same, Celtec will provide years of minimal color change. In addition, Celtec will not warp, rot, crack or peel like wood products in similar outdoor exposures.

Celtec was weathered in a “QUV” weatherometer by Vista Chemical Company along with a standard pipe compound, vinyl siding and another major expanded PVC brand. The test replicated two years of exposure outdoors in Arizona. Celtec in 3 mm and 6 mm thicknesses retained more of their respective color than did the major competitors’ brands of expanded PVC sheet for the same thicknesses.

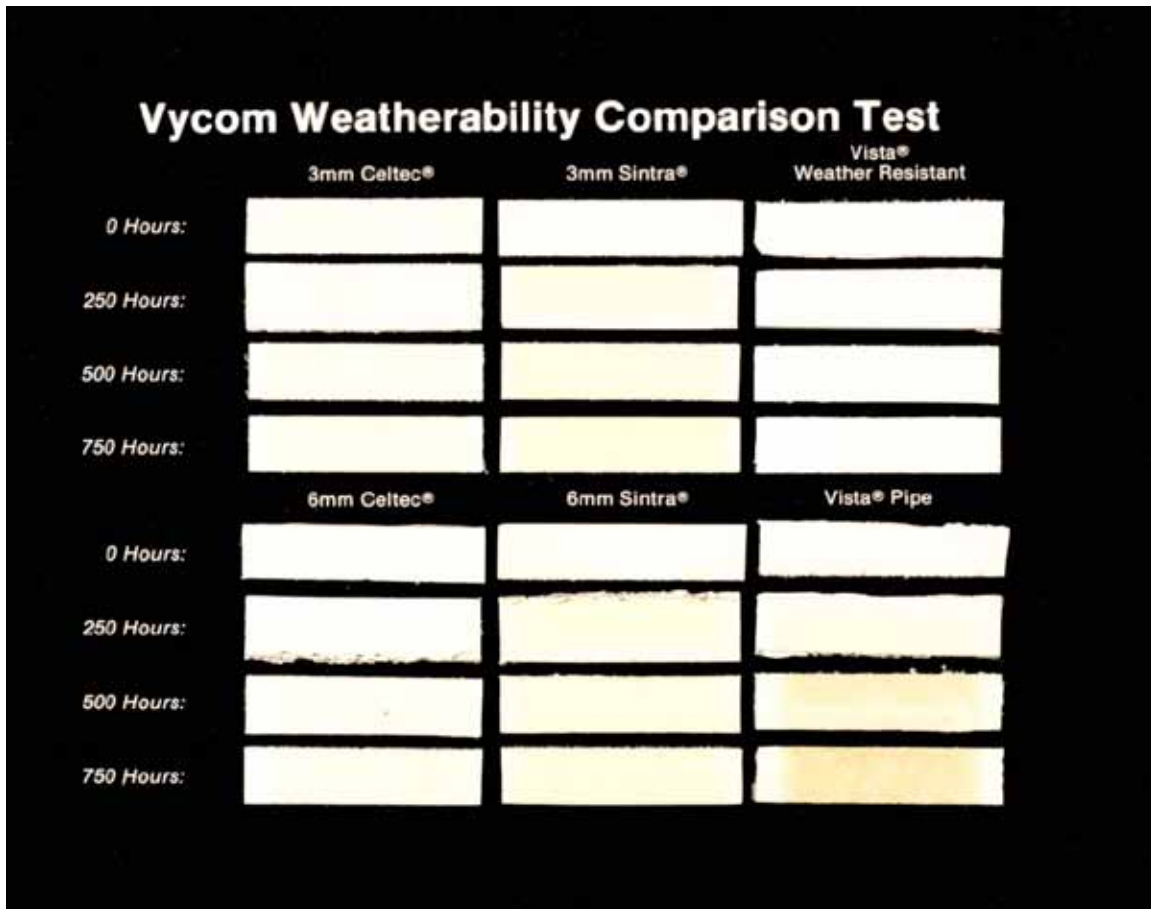

## Stress

Some silkscreen inks contain solvents that can cause environmental stress cracks. For more information, refer to the desired manufacturer's ink and solvent charts.



## Color in Foamed PVC

Foamed polyvinyl chloride (PVC) has become one of the most popular materials for a wide range of projects, whether the application involves exhibits and displays, signage, screen printing, photo mounting or various OEM fabrications. Yet, like other materials, foamed PVC has unique characteristics, and correct information about the nature of the product will contribute to more successful projects. Information about color in foamed PVC can be especially helpful in deciding how to use this type of material to its best advantage.

Closed-cell, foamed PVC is moisture resistant, and manufacturers recommend it for various time periods outdoors as well as for indoor use. The recommended outdoor time periods are directly related to the degree of color fastness desired, weathering requirements, and surface preparation, such as ultraviolet clearcoat. Manufacturers have conducted tests of fade resistance for time periods ranging from just three months' exposure to 30 months. While test results vary, one conclusion is obvious: the nature of PVC material in untreated or "natural" form makes it susceptible to color fade due to UV exposure over time—regardless of color or brand name. In one study, material samples in white, red and blue produced by three different manufacturers were tested for 30 months (readings taken with the Hunterlab color meter system using L, a, b, color coordinates). Very significant changes were seen in almost all samples except white, with changes of more than five "Delta E units" considered "dramatic." Delta E quantifies the change in the three-dimensional attributes of the Hunterlab color system for a measurement of total color difference from initial time of exposure. In fact, white material changes in a similar way, but because the primary change is "chalking," the change is not as noticeable.

There are several ways to reduce or eliminate the impact of color fading in foamed PVC material. One is to use white material itself, in which the fading is less noticeable. Other solutions include using a UV-resistant clear topcoat; using the foamed PVC material as a substrate for a vinyl film, laminate or covering; and painting the material with a weather-resistant paint, such as a two-part polyurethane. Because foamed PVC in white is often 20% to 30% less expensive than other colors, various surface treatments using white foamed PVC can be affordable alternatives.

A second basic fact of foamed PVC boards is that color will vary somewhat from manufacturer to manufacturer, from extrusion machine to extrusion machine, as

well as from batch to batch. (A common manufacturing range for color variation is three Delta E units. Many people believe that more than three Delta E units is “noticeable.”) Also, the perception of color can vary from the top of a sheet (side “A”) to the bottom (side “B”). Inherent in the manufacturing process for foamed PVC is some variation of surface texture between the top and bottom of a sheet. This may result in a different gloss level and the appearance of a slight difference in color, even though the color is homogeneous throughout the entire sheet. Subtle lines created by the extrusion process may also appear on one side of the material, again giving a slightly different perception of color or consistency.

The strong demand for foamed PVC has led manufacturers to make it available in a variety of stock colors; custom colors are also available. Yet, many of the issues affecting color in foamed PVC must be considered differently for custom colors than for standard colors.

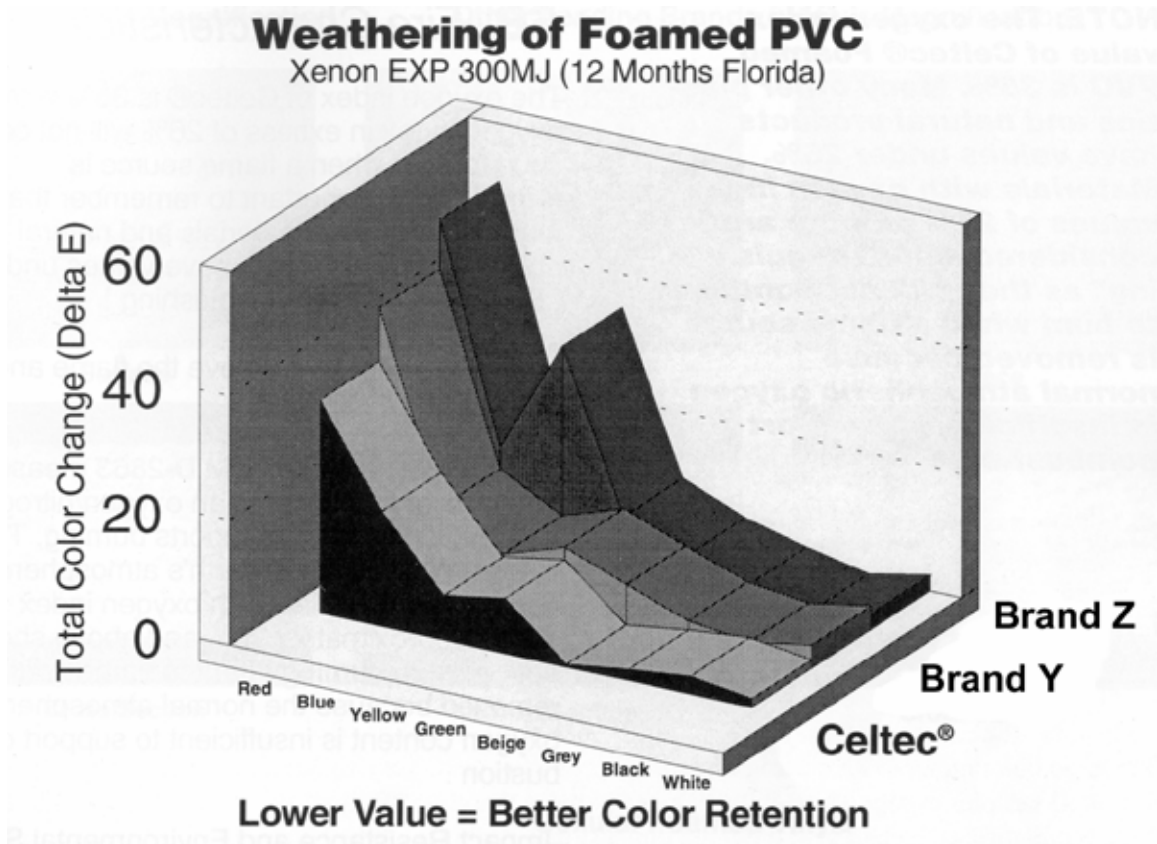

Production minimums for custom colors range between six and 45 metric tons, depending on the pigment required (custom or standard) and the amount of start-up time (involving scrap generation) that is needed to achieve the desired color. Darker custom colors require a heavier pigment load. That may also affect the other raw materials involved and affect the integrity of the product, involving such

factors as its density. In turn, some of the other variables already discussed can be affected. These include the top and bottom surface finish of the sheet and perception of color. Manufacturers typically request a signed-off color sample, written purchase order and acceptance of up to five Delta E units variation before they will provide the material.

While other materials such as acrylic and styrene offer smaller minimums, they do not, of course, offer all the fabrication capabilities, appearance and performance features that have led to the popularity of foamed PVC. Available in a wide range of standard thicknesses, it is the best substrate for screen printing, and it can be painted, usually without priming. The properties of foamed PVC allow faster heat bending and thermoforming. Special tools are not required for many fabrication steps, such as cutting, trimming or die cutting. The material provides a rigid, flat mounting surface, and it can be laminated to other materials. Its combination of economy and performance continues to make it an excellent value for a wide range of applications.

Each material has inherent characteristics which must be considered in the manufacturing process; the nature of the material should also be fully considered in selecting and using it. End-users should be able to expect correct and straightforward information from manufacturers and distributors about such issues. This will help to prevent misunderstanding, and it will result in more successful projects. That's good for all of us.



## Fire Characteristics

Any material having an oxygen index in excess of 26% will not continue to burn when a flame source is removed. The oxygen index of Celtec is 35%, which makes it self-extinguishing, meaning that when the flame source is removed, the burning stops. It is important to remember that many other plastic materials and natural products, such as wood, have values under 26%.

High oxygen index—ASTM D-2863 measures the percent of oxygen in an oxygen/nitrogen mixture that barely supports burning. The oxygen content of the earth's atmosphere is about 21%. Materials with oxygen index values of approximately 28% and above should not continue burning after the flame source is removed because the normal atmospheric oxygen content is insufficient to support combustion.

### Impact Resistance and Environmental Stress

Effect of Temperature—With decreasing temperature, there is a tendency towards decreased impact resistance.

Samples of 3 mm Celtec were conditioned in a freezer to a temperature of  $-10^{\circ}\text{C}$  for a period of twelve hours. The test bars were then impacted per ASTM D266 Charpy Impact—Test Method B (Specimens Unnotched). The “Cold Break” specimens retained 85% of the original room temperature impact strength.

**Celtec  
16X Magnification**



Surface

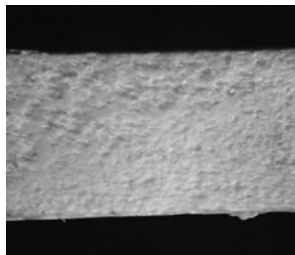

Cross-section

**Other Leading Brands  
16X Magnification**



Surface

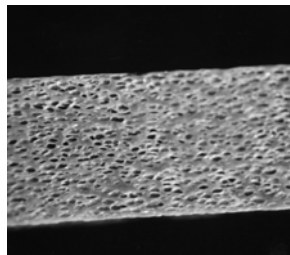

Cross-section

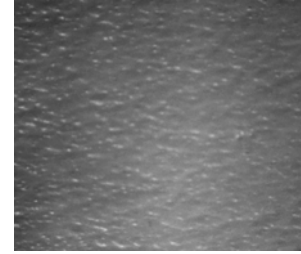

Surface

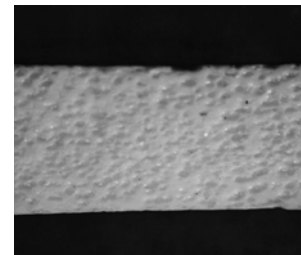

Cross-section

### **Cellular Foamed Vinyls**

“There are two types of cellular foamed vinyls: open cell and closed cell. In the closed cell type, each cell is individual, usually spherical in shape, and completely enclosed by plastic walls. This type of cell structure has good insulating properties as well as a high degree of buoyancy. In the open cell type, all the cells are interconnected. This type of cell structure is known for its absorbency and capillary action.”

Source: Encyclopedia of PVC; Vol. 2, Page 619.

A rigid foam PVC sheet or profile that is extruded via a free expansion process would thus be considered a closed cell foam. Examples of open cell types would be a foamable Plastisol or a sponge-like flexible plastic foam as is used in cushions or padding for furniture.

## Specifications for Celtec Foam PVC Sheet

### Typical Physical Properties

Property	ASTM Method	Celtec 700 Value	Celtec 550 Value
Density	D792	0.70 g/cm <sup>3</sup>	0.55 g/cm <sup>3</sup>
Water Absorption	D570	0.3%	0.15%
Water Absorption	D2842	0.9%	–

### Typical Mechanical Properties

Property	ASTM Method	Celtec 700 Value	Celtec 550 Value
Tensile Strength	D638	3000 psi	2256 psi
Tensile Modulus	D638	232,000 psi	144,000 psi
Flexural Strength	D790	–	3329
Flexural Modulus	D790	–	144,219
Nail Hold	D1761	–	35 Lbf/in of penetration Test result: 156 (3/4" thickness)
Nail Pulling (3-1/4" coated 16d nail)	D6117	–	Test result: 204 (1" thickness)
Screw Hold	D1761	–	680 Lbf/in of penetration Test result: 519 (3/4" thickness)
Screw Pulling (3" gold coarse screw)	D6117	–	Test result: 723 (1" thickness)
Staple Hold	D1761	–	180 Lbf/in of penetration
Gardner Impact	D4228	–	103 in/lbs
Izod Impact Strength	D256	0.53 ft-lb/in	–
Charpy Impact (Unnotched) (@23°C)	D256	8.1 ft lb/in	4.5 ft lb/in
Dielectric Strength	D149	112 kV/cm	–

[This page intentionally left blank.]

## Standard Specifications

### **USDA Approved – Incidental Contact**

Celtec® can be used for sign needs wherever food is processed or sold. It is lead-, cadmium- and barium-free.

### **U.L Classified**

Celtec® is the first foamed PVC to be U.L. Classified, meeting all three U.L. 1975 fire test requirements.

### **Fire Characteristics**

The oxygen index value of Celtec® is 35% Materials with a value of 28% or higher are considered self-extinguishing. For comparison, oak carries a value of 23% and birch carries a value of 21%.

### **Health and Environmental**

Celtec® contains no lead, cadmium, barium or zinc heat stabilizers. Celtec is made only with tin, which means that there are no special health, environmental or waste disposal problems.

[This page intentionally left blank.]

# Material Safety Data

# 7

---

## I. Product Identification

<b>Trade Name:</b>	Polyvinyl Chloride (PVC, Vintec I, Vintec II, Celtec) sheet
<b>Synonyms:</b>	Vinyl Polymers
<b>CAS Number(s):</b>	9002-86-2

## II. Components and Hazard Classification

<b>PVC Polymer:</b>	70-95%	
<b>Inert Fillers:</b>	0-30%	CaCO <sub>3</sub> , TiO <sub>2</sub>
<b>Heat Stabilizer:</b>	0-2%	Organotin Compounds
<b>Lubricants:</b>	0-4%	Calcium Stearate; Paraffin, Polyethylene, Polyamide Compounds or Esters
<b>Process Aids:</b>	0-2%	Acrylic Compounds
<b>Impact Modifiers:</b>	0-10%	CPE, ABS, MBS or Acrylic Compounds
<b>Colorants:</b>	0-2%	Organic and Inorganic Colorants
<b>Chemical Blowing Agents:</b>	0-1%	Azo Compounds or Sodium Bicarbonate

This product is an article as defined in 29 CFR 1910.1200. It will not result in exposure to hazardous chemicals under normal conditions of use. This product is not subject to the reporting requirements of Section 313 of Title III of the Superfund Amendments and Reauthorization Act of 1986 and 40 CFR Part 372.

### III. Physical Data

<b>Boiling Point (°F):</b>	Solid
<b>Specific Gravity (H<sub>2</sub>O=1):</b>	0.45 – 1.4
<b>Vapor Pressure (mm Hg.):</b>	Solid
<b>Melting Point:</b>	Decomposes before melting
<b>Solubility in Water:</b>	Solid
<b>Vapor Density:</b>	Solid
<b>Appearance and Odor:</b>	Finished sheet

### IV. Fire and Explosion Data

<b>Flash Point (Test Method):</b>	Not applicable
<b>Autoignition Temperature:</b>	Not applicable
<b>Flammable Limits in Air (% by Volume):</b>	
<b>Lower:</b>	Not applicable
<b>Upper:</b>	Not applicable
<b>Extinguishing Media:</b>	Water spray (fog), foam, dry chemical or CO <sub>2</sub>
<b>Special Fire Fighting Procedures:</b>	Cool exposed equipment with water spray. Use self-contained breathing apparatus if fighting fire in confined spaces.
<b>Unusual Fire and Explosion Hazard:</b>	PVC evolves hydrogen chloride, carbon monoxide and other toxic gases when burned. Exposure to combustion products may be fatal and should be avoided.



## V. Health Hazard Information

Pertains to dust or chips as a by-product of fabricating finished sheet.

<b>First Aid</b>	
<b>Eyes:</b>	Immediately flush with plenty of water. Call a physician if irritation persists.
<b>Skin:</b>	Flush skin with plenty of water. Remove contaminated clothing. Call a physician if irritation persists. Wash clothing before reuse.
<b>Inhalation:</b>	Remove to fresh air.
<b>Ingestion:</b>	Seek medical aid.
<b>Nature of Hazard</b>	
<b>Eyes:</b>	If exposed to high concentrations of dust, physical irritation of the eyes.
<b>Skin:</b>	This material is not expected to present a hazard to the intact skin. Molten sheet will produce thermal burns.
<b>Inhalation:</b>	Under normal conditions and with normal use, no inhalation hazard is presented. Please refer to Section VI, Fire and Explosion Data.
<b>Ingestion:</b>	No significant health hazard can be reasonably anticipated.
<b>Exposure Limits</b>	
	None established. ACGIH TLV of 10 mg/m <sup>3</sup> total dust as an 8-hour TWA is recommended.
<b>Toxicity Data</b>	
<b>Skin Contact:</b>	A review of the pertinent literature did not reveal specific information for PVC.
<b>Eye Contact:</b>	A review of the pertinent literature did not reveal specific information for PVC.
<b>Inhalation:</b>	Rodents exposed by the dietary or inhalation route for 6 to 24 months have shown no significant toxicological effects.
<b>Ingestion:</b>	See above.
<b>Special Precautions</b>	AVOID INHALATION OF COMBUSTION PRODUCTS.

## VI. Reactivity Data

<b>Conditions Contributing to Instability:</b>	Not applicable
<b>Incompatibility:</b>	Not applicable
<b>Hazardous Decomposition Products:</b>	Hydrogen chloride and other toxic fumes generated with combustion.
<b>Conditions Contributing to Hazardous Polymerization:</b>	Not applicable

## VII. Spill or Leak Procedures

When producing chips or dust from fabricating PVC sheet, sweep, scoop or vacuum and remove. Dispose of only in accordance with local, state and federal regulations.

## VIII. Special Protection Information

Pertains to dust or chips as a by-product of fabricating finished sheet.

<b>Ventilation Recommendations</b>	
	General ventilation when fabricating and nuisance dust control.
<b>Specific Personal Protective Equipment</b>	
<b>Respiratory Protection:</b>	If dust is produced during handling, an approved particulate filter respirator should be used.
<b>Eyes:</b>	Safety glasses or goggles.
<b>Gloves:</b>	Necessary when handling hot or molten sheet.
<b>Other Clothing and Equipment:</b>	As necessary when handling hot or molten sheet.

## IX. Shipping, Transfer and Storage

<b>Shipping Information</b>	
	Non-hazardous for transportation purposes
<b>Transportation and Storage</b>	
<b>Usual Shipping Containers:</b>	Palletized sheets
<b>Storage Transport Temperature:</b>	Sustained temperatures above 150°F may cause slow degradation.
<b>Electrostatic Accumulation Hazard:</b>	Yes