

# Instruction Manual



PHOENIX MODEL®



## CESSNA SKYLANE 182

GP/EP SCALE 1:5 ¼ ARF Size 1.20/20cc

### SPECIFICATION

- Wingspan: 2075mm (81.7 in)
- Length: 1624mm (64 in)
- Flying weight: 5.6-5.8 kg
- Wing area: 52.6 dm<sup>2</sup>
- Wing loading: 95g/dm<sup>2</sup>
- Wing type: Naca airfoils
- Covering type: Genuine ORACOVER®
- Gear type: Aluminum Hi-grade for main gear and suspension spring wire for nose gear (included)
- Spinner size: Plastic 70mm (included)
- Radio: 6 channel minimum (not included)
- Servo: 8 standard servo: 2 aileron; 2 flap; 2 elevator; 1 rudder; 1 throttle (not included)
- Recommended receiver battery: 4.8-6V / 1200-2000mAh NiMH (not included)
- Servo mount: 21mm x 42 mm
- Propeller: suit with your engine
- Engine: 1.20/ 2-stroke or 1.40/4-stroke glow engine or 20cc gas engine (not included)
- Motor: brushless outrunner 1600-2200 W, 450 KV (not included)
- Gravity CG: 85 mm (3.3 in) Back from the leading edge of the wing, at the fuselage
- Control throw Ailerons: Low: 10mm up/down, 10% expo; High: 13mm up/down, 10% expo
- Control throw Elevators: Low: 10mm up/down, 12% expo; High: 13mm up/down, 12% expo
- Control throw Rudder: Low: 20mm right/left, 15% expo; High: 30mm right/left, 15% expo
- Control throw Flaps: Mid: 15mm down; Landing: 20mm down
- Experience level: Intermediate
- Plane type: Scale Civilian

### RECOMMENDED MOTOR AND BATTERY SET UP

- Motor: RIMFIRE 1.20 (not included)
- Lipo cell: 6 cells / 5500 – 6000mAh (not included)
- Esc: 80A (not included)

## TABLE OF CONTENTS

Introduction .....	1	Installing the engine .....	12
Warranty.....	2	Installing the motor and battery .....	12
Disclaimer.....	2	Engine installation	
Safety precaution .....	2	Installing the throttle pushrod housing .....	13
Important building notes.....	2	Fuel tank installation	
Suggestion.....	2	Installing the stopper assembly .....	13
Flight warnings.....	2	Servo installation	
Flight warnings.....	3	Installing the fuselage servos .....	14
Covering tools.....	3	Installing the elevator pushrod .....	14
Adhesives and required tools .....	3	Installing the rudder pushrod .....	15
Academy of model aeronautics national		Installing the throttle .....	16
model aircraft safety code.....	3	Mounting the cowl .....	17
Preparations .....	5	Final assembly	
Installing the ailerons .....	5	Installing the spinner.....	17
Installing the aileron servos .....	5	Installing the receiver and battery .....	17
Installing the control horns.....	6	Installing the switch .....	18
Installing the control horns for flap .....	6	Installing the wing strut .....	18
Installing the aileron linkages .....	7	Installing the pilot .....	19
Installing the flap linkage .....	7	Installing the door .....	19
Installing the wing to the fuselage .....	8	Balancing .....	20
Horizontal stabilizer installation .....	8	Lateral balance .....	20
Vertical stabilizer installation .....	9	Control throws .....	20
Installing the front gear .....	10	Flight preparation pre flight check .....	21
Installing the wheel pants .....	11	For your radio installation	
Main gear installation		Basic connection for airplane	
Installing the main landing gear .....	11	and adjustment of servos .....	21

## INTRODUCTION

Thank you for purchasing Phoenix Model products. With over 20 years experience in production and fly testing, Phoenix Model is committed to bring the best quality products and good service to customers. Along with a team of creative engineers and skilled workers, we will always accompany with customers by our great experiences, fully enthusiasm... which will burn our passion!! Joining with us to explore and conquer challenges in the sky ...

Your satisfaction is our success. Please read through this manual before starting construction.

**Academy of Model Aeronautics:** If you are not already a member of the AMA, please join! The AMA is the governing body of model aviation and membership provides liability insurance coverage, protects modelers' rights and interests and is required to fly at most R/C sites.

**Academy of Model Aeronautics**

5151 East Memorial Drive Muncie, IN 47302-9252

Tele. (800) 435-9262

Fax (765) 741-0057

Or via the Internet at: <http://www.modelaircraft.org>



**WARRANTY**

Phoenix Model guarantees the component parts in this kit to be free from defects in both material and workmanship at the date of purchase by the purchaser.

This warranty does not cover cosmetic damage or damage due to acts of God, accident, misuse, abuse, negligence, commercial use, or modification of or to any part of the Product.

This warranty does not cover damage due to improper installation, operation, maintenance, or attempted repair by anyone other than Phoenix Model.

Further, Phoenix Model reserves the right to change or modify this warranty without notice.

**DISCLAIMER**

Read this disclaimer carefully before using this product. Please strictly follow the instruction manual to assemble and use this.

In that Phoenix Model has no control over the final assembly or material used for final assembly, Phoenix Model is not responsible for loss of use, or other incidental or consequential damages.

Furthermore, Phoenix Model cannot be held liable for personal injury or property damage caused by the use or misuse of Phoenix Model products. By the act of using the user-assembled products, the user accepts all resulting liability.

**SAFETY PRECAUTION**

- This is not a toy and pilots must be over the age of 14
- Be sure that no other flyers are using your radio frequency.
- Do not smoke near fuel
- Store fuel in a cool, dry place, away from children and pets.
- Wear safety glasses.
- The glow plug clip must be securely attached to the glow plug.
- Do not flip the propeller with your fingers.
- Keep loose clothing and wires away from the propeller.
- Do not start the engine if people are near. Do not stand in line with the side of the propeller.
- Make engine adjustments from behind the propeller only. Do not reach around the spinning propeller.
- Moisture causes damage to electronics. Avoid water exposure to all equipment not specifically designed and protected for this purpose.

**IMPORTANT BUILDING NOTES**

- Please trial fit all the parts. Make sure you have the correct parts and that they fit and are aligned properly before gluing! This will assure proper assembly. This kit is hand made from natural materials, every plane is unique and minor adjustments may have to be made. However, you should find the fit superior and assembly simple.

- The painted and plastic parts used in this kit are fuel proof. However, they are not tolerant of many harsh chemicals including the following: paint thinner, C/A glue accelerator, C/A glue debonder and acetone. Do not let these chemicals come in contact with the colors on the covering and the plastic parts.

- Some parts included in this kit such as the cowl or wheel pants are made of fiberglass, the fibers of which may cause eye, skin and respiratory tract irritation. Never blow into a part to remove fiberglass dust, as the dust will blow back into your eyes. Always wear safety goggles, a particle mask and rubber gloves when grinding, drilling and sanding fiberglass parts. Vacuum the parts and the work area thoroughly after working with fiberglass parts.

**SUGGESTION**

To avoid scratching your new airplane, do not unwrap the pieces until they are needed for assembly. Cover your workbench with an old towel or brown paper, both to protect the aircraft and to protect the table. Keep a couple of jars or bowls handy to hold the small parts after you open the bag.

**FLIGHT WARNINGS**

- Always operate in open areas, away from factories, hospitals, schools, buildings and houses etc.
- NEVER fly your aircraft close to people or built up areas.
- NEVER fly near power lines, aerials or other dangerous areas including airports, motorways etc.
- NEVER fly in wet conditions or on windy or stormy days.
- ALWAYS adjust the engine from behind the propeller, and do not allow any part of your body to be in line with the propeller.
- THE PROPELLER IS DANGEROUS Keep fingers, clothing (ties, shirt sleeves, scarves) or any other loose objects that could be caught or drawn in, away from the propeller. Take care at ALL times.
- NEVER use damaged or deformed propellers or spinners.
- Keep all onlookers (especially small children and animals) well back from the area of operation. This is a flying aircraft, which will cause serious injury in case of impact with a person or animal.
- DO NOT dispose of empty fuel containers on a fire, this can lead to an explosion.

**FLIGHT WARNINGS**

- When ready to fly, first extend the transmitter aerial.
- Switch on the transmitter.
- Switch on the receiver.
- Check that the wings are correctly fitted to the fuselage.
- Operate the control sticks on the transmitter and check that the control surfaces move freely and in the CORRECT directions.
- Check that the transmitter batteries have adequate power.
- ALWAYS take off into the wind.
- If the model does not respond correctly to the controls, land it as soon as possible and correct the fault.
- ALWAYS land the model INTO the wind, this ensures that the model lands at the slowest possible speed.
- Switch off the receiver.
- Switch off the transmitter.
- Empty the fuel tank after flying, fuel left in the tank can cause corrosion and lead to engine problems.

**COVERING TOOLS**

- Top Flite® MonoKote® Sealing Iron
- Top Flite Hot Sock Iron Cover
- Top Flite MonoKote Trim Seal Iron
- Top Flite MonoKote Heat Gun

**ADHESIVES AND REQUIRED TOOLS**

- Thin CA
- 30-minute epoxy
- 6-minute epoxy
- Threadlocker thread locking cement
- Mixing sticks
- Mixing cups (GPMR8056)
- Epoxy brushes
- Denatured alcohol
- Canopy Glue
- Felt-tipped pen or pencil
- Flat screwdriver
- Adjustable wrench
- Drill
- Hobby knife
- Masking tape
- Phillips screwdriver (large)
- Phillips screwdriver (small)
- Ruler
- Sandpaper
- Soldering iron
- Solder
- Hex wrench
- Drill bit: 1/16-inch (1.5mm), 5/64-inch (2mm), 1/8-inch (3,2mm), 3/16-inch (4,8mm), 11/64-inch (4.5mm), 13/64-inch (5,2mm), 1/4-inch (6,4mm)

**Academy of Model Aeronautics National Model Aircraft Safety Code****Effective January 1, 2014**

A. GENERAL: A model aircraft is a non-human-carrying aircraft capable of sustained flight in the atmosphere. It may not exceed limitations of this code and is intended exclusively for sport, recreation, education and/or competition. All model flights must be conducted in accordance with this safety code and any additional rules specific to the flying site.

1. Model aircraft will not be flown:
  - (a) In a careless or reckless manner.
  - (b) At a location where model aircraft activities are prohibited.
2. Model aircraft pilots will:
  - (a) Yield the right of way to all human-carrying aircraft.
  - (b) See and avoid all aircraft and a spotter must be used when appropriate. (AMA Document #540-D.)
  - (c) Not fly higher than approximately 400 feet above ground level within three (3) miles of an airport without notifying the airport operator.
  - (d) Not interfere with operations and traffic patterns at any airport, heliport or seaplane base except where there is a mixed use agreement.
  - (e) Not exceed a takeoff weight, including fuel, of 55 pounds unless in compliance with the AMA Large Model Airplane program. (AMA Document 520-A.)
  - (f) Ensure the aircraft is identified with the name and address or AMA number of the owner on the inside or affixed to the outside of the model aircraft. (This does not apply to model aircraft flown indoors.)
  - (g) Not operate aircraft with metal-blade propellers or with gaseous boosts except for helicopters operated under the provisions of AMA Document #555.
  - (h) Not operate model aircraft while under the influence of alcohol or while using any drug that could adversely affect the pilot's ability to safely control the model.
  - (i) Not operate model aircraft carrying pyrotechnic devices that explode or burn, or any device which propels a projectile or drops any object that creates a hazard to persons or property.

**Exceptions:**

- Free Flight fuses or devices that burn producing smoke and are securely attached to the model aircraft during flight.
- Rocket motors (using solid propellant) up to a G-series size may be used provided they remain attached to the model during flight. Model rockets may be flown in accordance with the National Model Rocketry Safety Code but may not be launched from model aircraft.

- Officially designated AMA Air Show Teams (AST) are authorized to use devices and practices as defined within the Team AMA Program Document. (AMA Document #718.)
- (j) Not operate a turbine-powered aircraft, unless in compliance with the AMA turbine regulations. (AMA Document #510-A.)
- 3. Model aircraft will not be flown in AMA sanctioned events, air shows or model demonstrations unless:
  - (a) The aircraft, control system and pilot skills have successfully demonstrated all maneuvers intended or anticipated prior to the specific event.
  - (b) An inexperienced pilot is assisted by an experienced pilot.
- 4. When and where required by rule, helmets must be properly worn and fastened. They must be OSHA, DOT, ANSI, SNELL or NOCSAE approved or comply with comparable standards.
- B. RADIO CONTROL (RC)
  - 1. All pilots shall avoid flying directly over unprotected people, vessels, vehicles or structures and shall avoid endangerment of life and property of others.
  - 2. A successful radio equipment ground-range check in accordance with manufacturer's recommendations will be completed before the first flight of a new or repaired model aircraft.
  - 3. At all flying sites a safety line(s) must be established in front of which all flying takes place. (AMA Document #706.)
    - (a) Only personnel associated with flying the model aircraft are allowed at or in front of the safety line.
    - (b) At air shows or demonstrations, a straight safety line must be established.
    - (c) An area away from the safety line must be maintained for spectators.
    - (d) Intentional flying behind the safety line is prohibited.
  - 4. RC model aircraft must use the radio-control frequencies currently allowed by the Federal Communications Commission (FCC). Only individuals properly licensed by the FCC are authorized to operate equipment on Amateur Band frequencies.
  - 5. RC model aircraft will not knowingly operate within three (3) miles of any pre-existing flying site without a frequency-management agreement. (AMA Documents #922 and #923.)
  - 6. With the exception of events flown under official AMA Competition Regulations, excluding takeoff and landing, no powered model may be flown outdoors closer than 25 feet to any individual, except for the pilot and the pilot's helper(s) located at the flightline.
  - 7. Under no circumstances may a pilot or other person touch an outdoor model aircraft in flight while it is still under power, except to divert it from striking an individual.
  - 8. RC night flying requires a lighting system providing the pilot with a clear view of the model's attitude and orientation at all times. Hand-held illumination systems are inadequate for night flying operations.
  - 9. The pilot of an RC model aircraft shall:
    - (a) Maintain control during the entire flight, maintaining visual contact without enhancement other than by corrective lenses prescribed for the pilot.
    - (b) Fly using the assistance of a camera or First-Person View (FPV) only in accordance with the procedures outlined in AMA Document #550.
    - (c) Fly using the assistance of autopilot or stabilization system only in accordance with the procedures outlined in AMA Document #560.
- C. FREE FLIGHT
  - 1. Must be at least 100 feet downwind of spectators and automobile parking when the model aircraft is launched.
  - 2. Launch area must be clear of all individuals except mechanics, officials, and other fliers.
  - 3. An effective device will be used to extinguish any fuse on the model aircraft after the fuse has completed its function.
- D. CONTROL LINE
  - 1. The complete control system (including the safety thong where applicable) must have an inspection and pull test prior to flying.
  - 2. The pull test will be in accordance with the current Competition Regulations for the applicable model aircraft category.
  - 3. Model aircraft not fitting a specific category shall use those pull-test requirements as indicated for Control Line Precision Aerobatics.
  - 4. The flying area must be clear of all utility wires or poles and a model aircraft will not be flown closer than 50 feet to any above-ground electric utility lines.
  - 5. The flying area must be clear of all nonessential participants and spectators before the engine is started.

### PREPARATIONS

Remove the tape and separate the ailerons from the wing and the elevators from the stab. Use a covering iron with a covering sock on high heat to tighten the covering if necessary. Apply pressure over sheeted areas to thoroughly bond the covering to the wood.



### INSTALLING THE AILERONS

1. Test fit the ailerons to the wing with the hinges. If the hinges don't remain centered, stick a pin through the middle of the hinge to hold it in position.

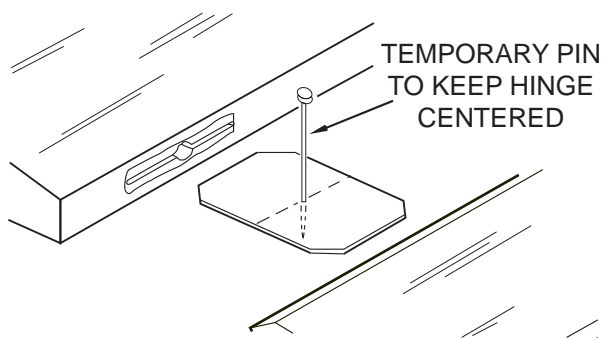

2. Apply six drops of thin CA to the top and bottom of each hinge. Do not use CA accelerator. After the CA has fully hardened, test the hinges by pulling on the aileron.

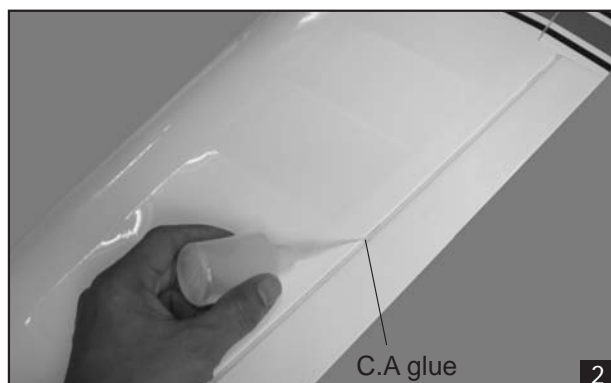

### INSTALLING THE AILERON SERVOS

1. Install the rubber grommets and brass eyelets onto the aileron servo.
2. Using a modeling knife, remove the covering from over the pre-cut servo arm exit hole on the aileron servo tray / hatch. This hole will allow the servo arm to pass through when installing the aileron pushrods.



3. Place the servo into the servo tray. Center the servo within the tray and drill 1,6mm pilot holes through the block of wood for each of the four mounting screws provided with the servo.



4. Using the thread as a guide and using masking tape, tape the servo lead to the end of the thread: carefully pull the thread out. When you have pulled the servo lead out, remove the masking tape and the servo lead from the thread.

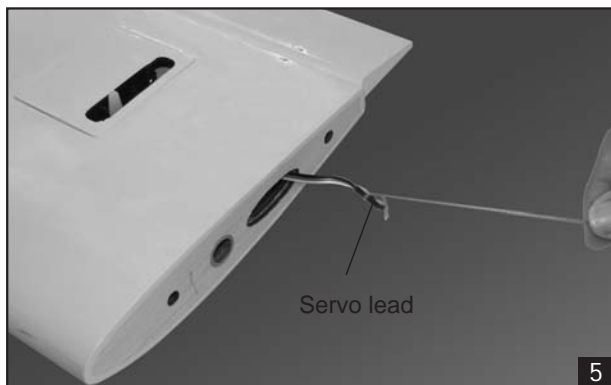

5. Place the aileron servo tray / hatch into the servo box on the bottom of the wing and drill 1,6mm pilot holes through the tray and the servo box for each of the four mounting screws. Secure the servo tray in place using the mounting screws provided ( 2mm x 12mm ).



6. Repeat step # 2 - # 5 to install the second aileron servo in the opposite wing half.



### INSTALLING THE CONTROL HORNS

1. One aileron control horn is positioned on each aileron. Using a ruler and a pen, locate and mark the location of the control horn. It should be mounted on the bottom side of the aileron at the leading edge, in line with the aileron pushrod.
2. Remove the covering and install the control horn.

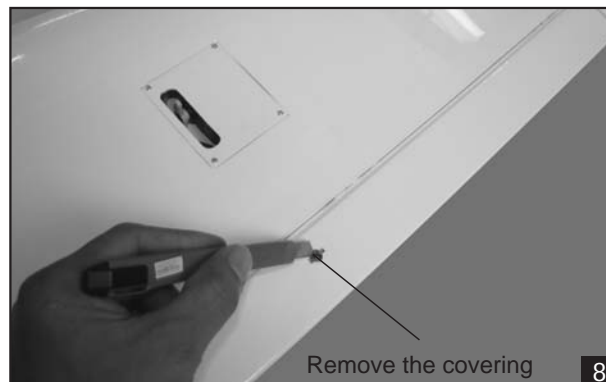

3. Repeat step # 1 - # 2 to install the control horn on the opposite aileron.

### INSTALLING THE CONTROL HORNS FOR FLAP

Repeat step #1 - #3 from installing the control horn for aileron to install the control horn for flap.





11

## **INSTALLING THE AILERON LINKAGES**

1. Working with the aileron linkage for now, thread one nylon clevis onto one of the 2mm x 180mm threaded wires.

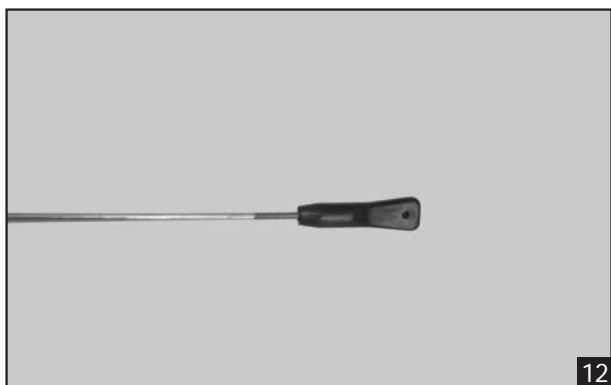

12

2. Attach the clevis to the control horn.

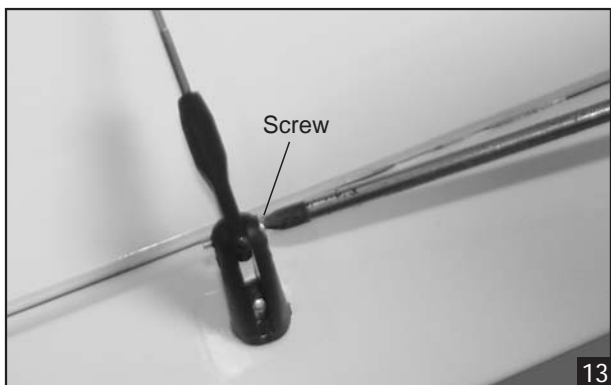

13

3. Locate one nylon servo arm, and using wire cutters, remove all but one of the arms. Using a 2mm drill bit, enlarge the third hole out from the center of the arm to accommodate the aileron pushrod wire.
4. Plug the aileron servo into the receiver and center the servo. Install the servo arm onto the servo. The servo arm should be perpendicular to the servo and point toward the middle of the wing.

5. Center the aileron and hold it in place using a couple of pieces of masking tape.
6. With the aileron and aileron servo centered, carefully place a mark on the aileron pushrod wire where it crosses the hole in the servo arm.
7. Using pliers, carefully make a 90 degree bend down at the mark made. Cut off the excess wire, leaving about 4mm beyond the bend.

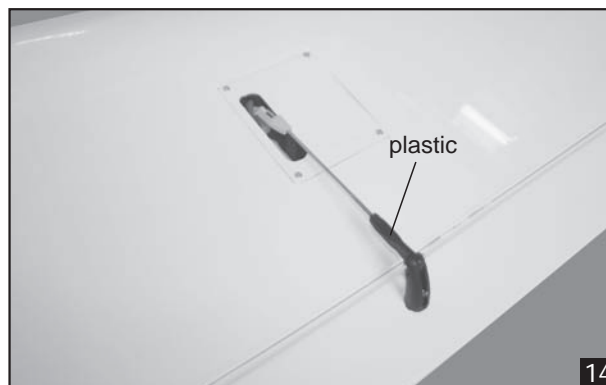

14

8. Insert the 90 degree bend down through the hole in the servo arm. Install one nylon snap keeper over the wire to secure it to the arm. Install the servo arm retaining screw and remove the masking tape from the aileron.
9. Repeat step # 4 - # 8 to install the second aileron linkage. After both linkages are completed, connect both of the aileron servo leads using a Y-harness you have purchased separately.

## **INSTALLING THE FLAP LINKAGE**

Repeat step #1 - #9 from installing the aileron linkage to install the flap linkage.

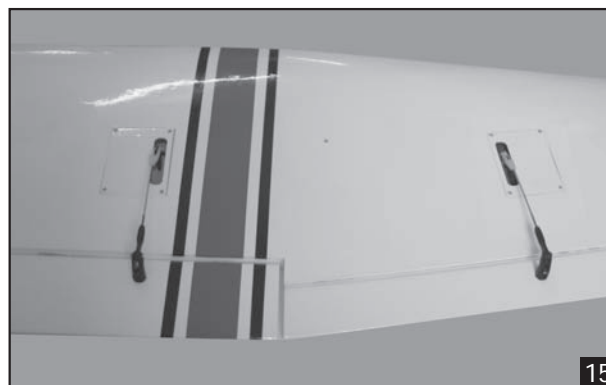

15



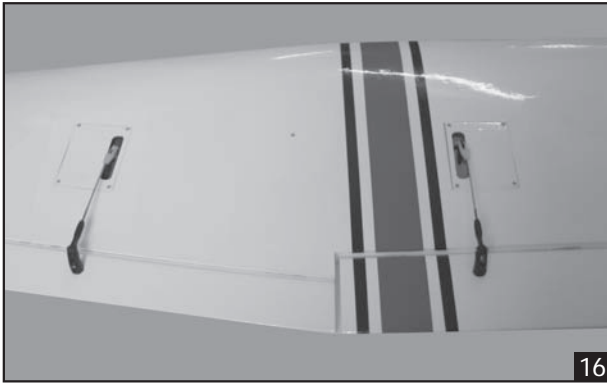

**INSTALLING THE WING TO THE FUSELAGE**

Attach the wings to the joiner tube and secure the wing panels to the fuselage.

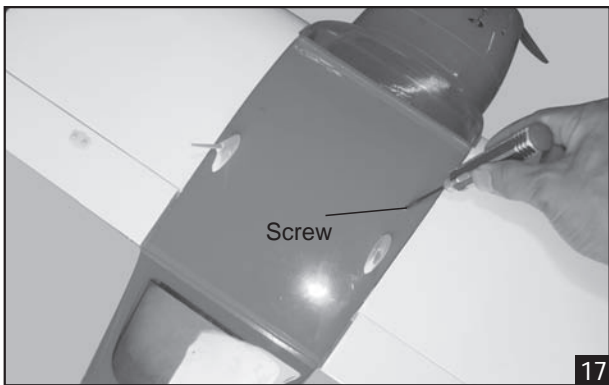

**HORIZONTAL STABILIZER INSTALLATION**

1. Using a modeling knife, cut away the covering from the fuselage for the stabilizer and remove it.

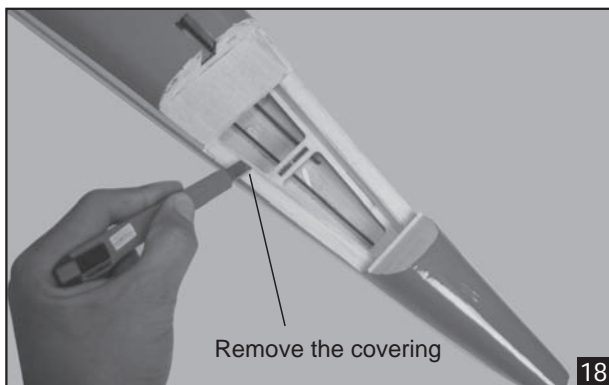

2. Draw a center line onto the horizontal stabilizer.



3. Check the fit of the horizontal stabilizer. Make sure the horizontal stabilizer is square and centered to the fuselage by taking measurements, but don't glue anything yet.

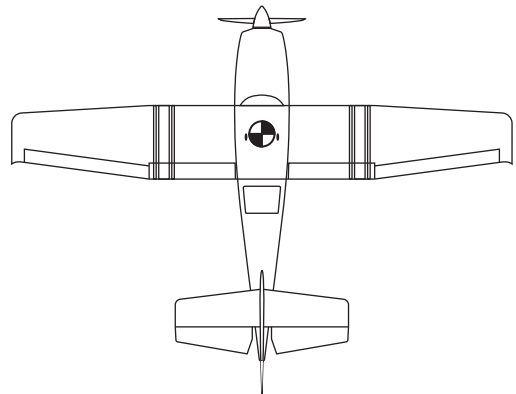
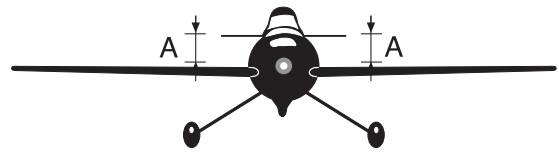

4. With the horizontal stabilizer correctly aligned, mark the shape of the fuselage on the top and bottom of the tail plane using a water soluble / non-permanent felt-tip pen.

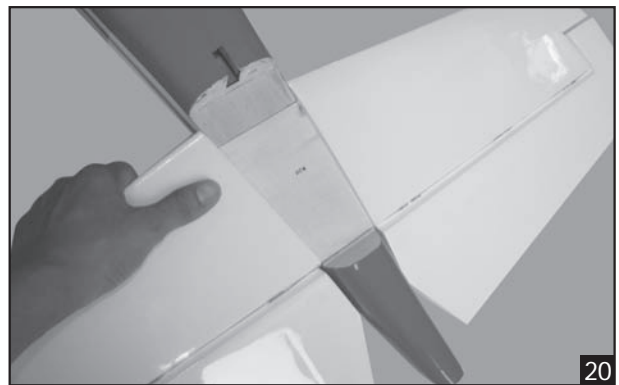

5. Remove the stabilizer. Using the lines you just drew as a guide, carefully remove the covering from between them using a modeling knife.



*When cutting through the covering to remove it, cut with only enough pressure to only cut through the covering it's self. Cutting into the balsa structure may weaken it. This could lead to possible failure during flight.*

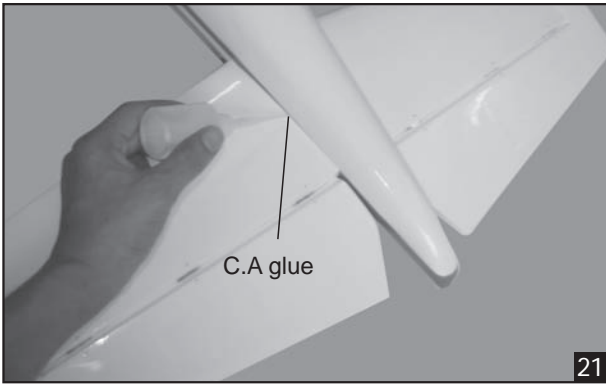

6. When you are sure that everything is aligned correctly, mix up a generous amount of 30 minute epoxy. Apply a thin layer to the top and bottom of the stabilizer mounting area and to the stabilizer mounting platform sides in the fuselage. Slide the stabilizer in place and re-align. Double check all of your measurements one more time before the epoxy cures. Remove any excess epoxy using a paper towel and rubbing alcohol and hold the stabilizer in place with T-pins or masking tape.

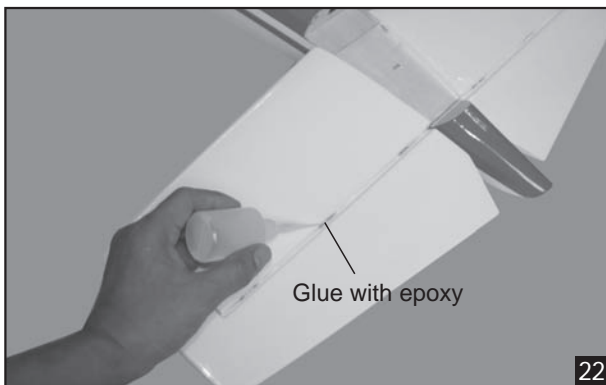

7. After the epoxy has fully cured, remove the masking tape or T-pins used to hold the stabilizer in place and carefully inspect the glue joints. Use more epoxy to fill in any gaps that were not filled previously and clean up the excess using a paper towel and rubbing alcohol.

**VERTICAL STABILIZER INSTALLATION**

1. Using a modeling knife, remove the covering on the top of the fuselage for the vertical stabilizer.

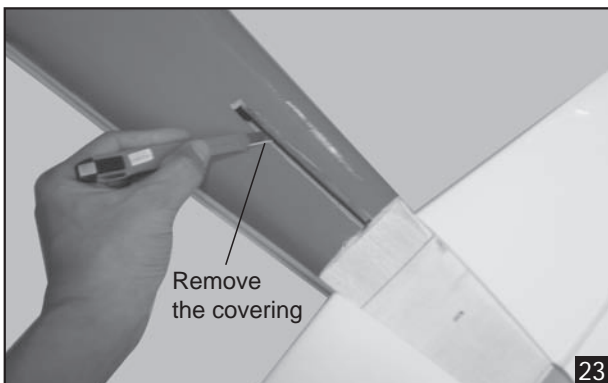

2. Place the vertical stabilizer into the fuselage. Mark the shape of the fuselage on the left and right sides of the vertical stabilizer using a felt-tip pen.
3. Now, remove the vertical stabilizer and using a modeling knife, carefully cut just inside the marked lines and remove the film on both sides of the vertical stabilizer. Just as you did with the horizontal stabilizer, make sure you only press hard enough to cut the film, not the balsa vertical stabilizer.

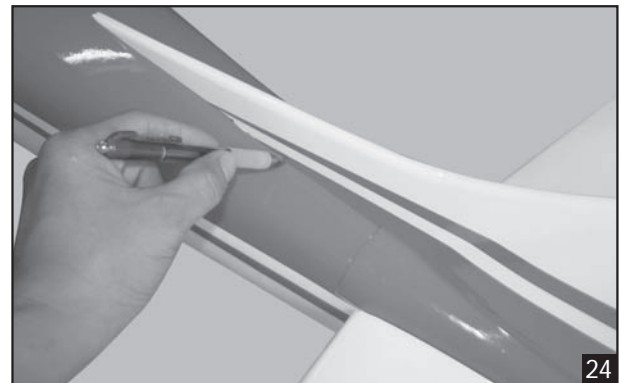

4. Using the block of the rudder as a guide and mark the shape of it on the top of the elevator.

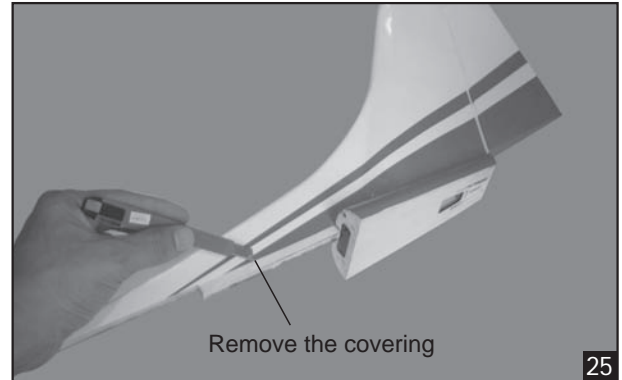

5. Remove the covering from the elevator and also the rear on the block of rudder.

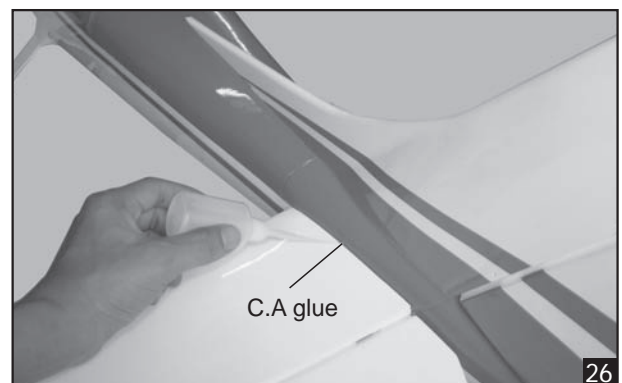

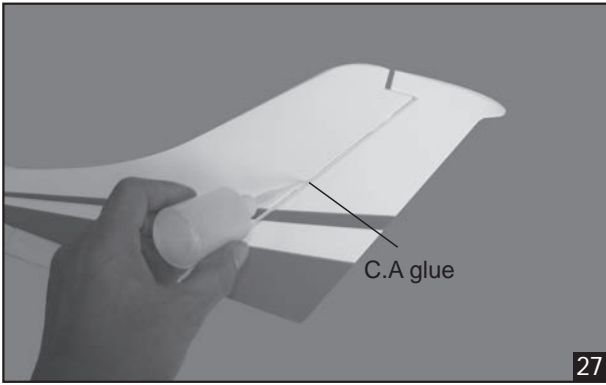

6. Place the vertical stabilizer back in place. Using a triangle, check to ensure that the vertical stabilizer is aligned 90 degree to the horizontal stabilizer.
7. When you are sure that everything is aligned correctly, mix up a generous amount of 30 minute epoxy. Apply a thin layer to the slot in the mounting platform and to the vertical stabilizer mounting area. Apply epoxy to the lower rudder hinge. Set the stabilizer in place and re-align. Double check all of your measurements once more before the epoxy cures. Remove any excess epoxy using a paper towel and rubbing alcohol and hold the stabilizer in place with T-pins or masking tape. Allow the epoxy to fully cure before proceeding.

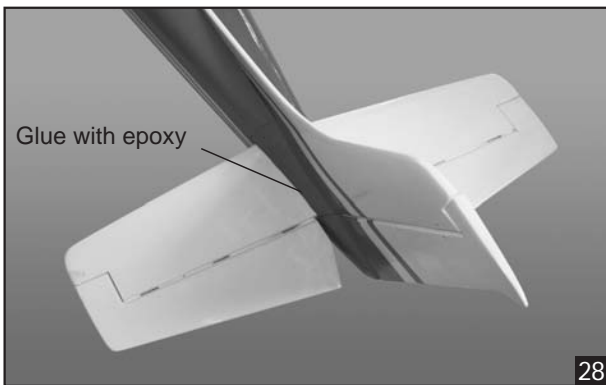

**INSTALLING THE FRONT GEAR**

1. Install the wheel pant of the front gear.



2. Install the wheels onto the axles using the two wheel collars and set screws provided. The wheels should be centered on the axles with a wheel collar on each side, holding them in place. Tighten the set screws on the collars to secure them in place. The wheels should rotate freely. You should apply a small drop of lock-Tite thread lock to each set screw to prevent them from coming loose.
3. Working with the preinstalled nylon steering housing, position it so the end of it is flush with the front of the firewall. When satisfied with the fit, glue the housing to the firewall from the inside of the fuselage using 5 Minute Epoxy.
4. The preinstalled wire steering pushrod has a factory made Z-Bend on the front end of it. Connect the nylon steering arm to this pushrod. The pushrod should be installed in the outermost hole in the steering arm.

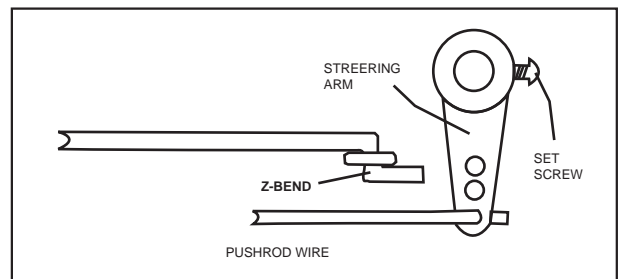

5. Locate the nose gear wire. Slide the nose gear wire up through the lower portion of the nose gear block, then through the nylon steering arm, then through the upper portion of the nose gear block.

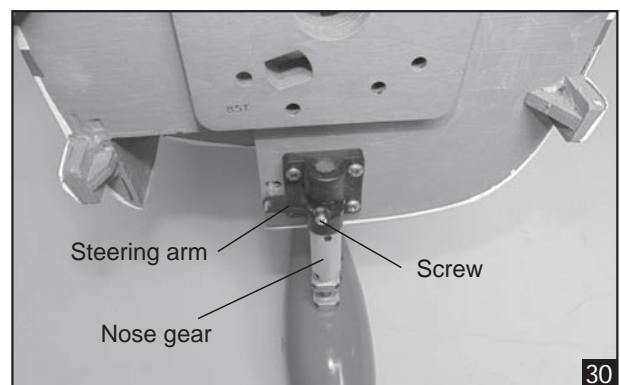

6. With the nose gear wire straight, angle the nylon steering arm about 30° forward of the fire-wall and tighten the set screw. Angling the arm forward like this will allow room for the arm to move back for more adequate steering.

7. Install the remaining wheel onto the axle using the two wheel collars and set screws provided. The wheel should be centered on the axle with a wheel collar on each side, holding it in place. Tighten the set screws on the collars to secure them in place. The wheel should rotate freely. You should apply a small drop of Lock\_tite thread lock to each set screw to prevent them from coming loose.

**INSTALLING THE WHEEL PANTS**

1. Locate the wheel pants from the hardware bag. Mark the locations of the mounting axles onto the wheel pants. The locations of the two mounting holes are the middle of the wheel opening, on right side, left side and 10mm from the bottom of the wheel pant.
2. Using a 5mm drill bit, carefully drill two pilot holes through the wheel pant at the TWO marks you made.

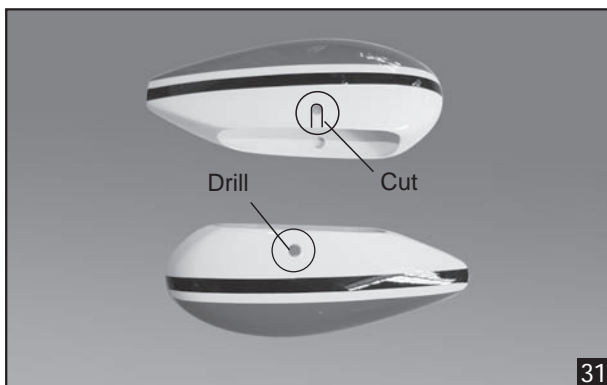

3. Using a modeling knife, carefully cut out two line from the margin of the hole onto the wheel pant.  
Just cut only one side of the wheel pant, where the main gear will install. Be sure to make a left and right wheel pant.
4. Slide a 4.5mm nut/ two 16mm flat washers / 4.5mm nut / collar / wheel / collar onto the axle.
5. Slide the axle assembly into the wheel pant.

**!** *There are just one nut and two flat washers outside of the wheel pant.*

6. Remove one nut, one flat washer. Attach the main landing gear to the axle.
7. Center both collars and wheel in the middle of the wheel pant, lock both collars in place using a hexagon 2mm screw.
8. With the landing gear in place, tighten two nuts.

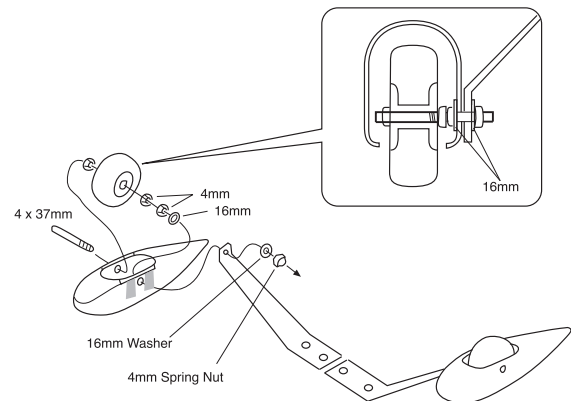
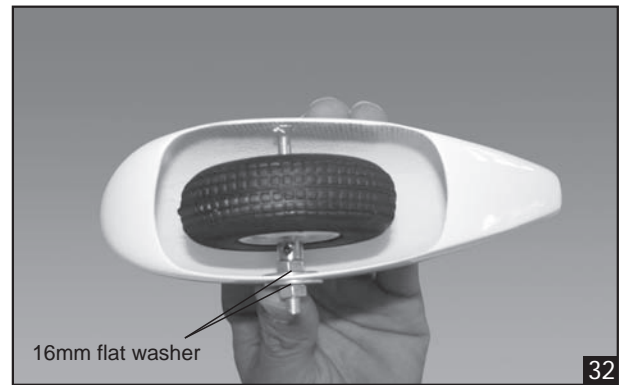

**!** *After installing the wheel pant, apply a small drop of thin C/A to the bottom nut.*

9. Repeat step # 1-8 to install the second wheel pant assembly.

**MAIN GEAR INSTALLATION**

**INSTALLING THE MAIN LANDING GEAR**

1. Four nuts have been installed at the factory.
2. Install main landing gear into the fuselage using (4) 4mm x 20mm machine screws and 16mm flat washers provided in the kit.

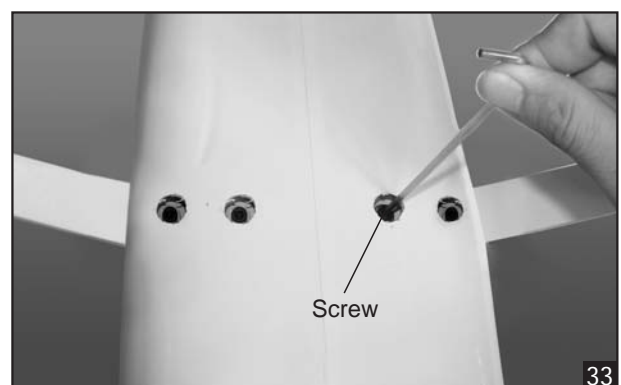

**INSTALLING THE ENGINE**

Locate the long piece of wire used for the throttle pushrod. One end of the wire has been pre-bend in to a "Z" bend at the factory. This "Z" bend should be inserted into the throttle arm of the engine when the engine is fitted onto the engine mount. Fit the engine to the engine mount using the screws provided.

**Install with OS 120 two stroke**

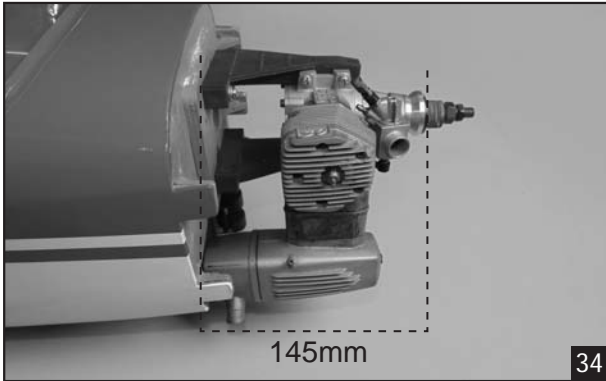

34

**Install with OS 22cc Engine**

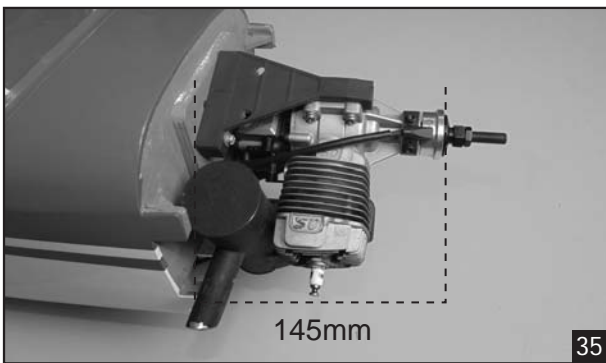

35

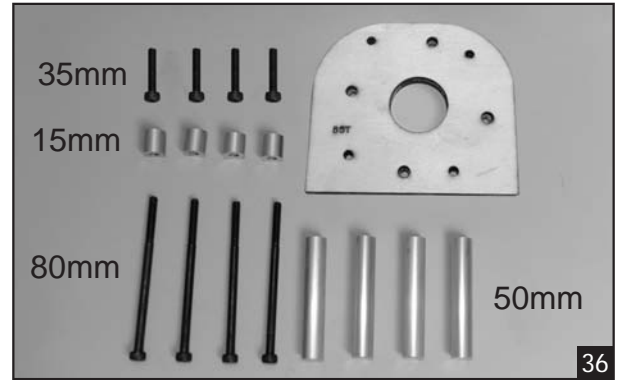

36

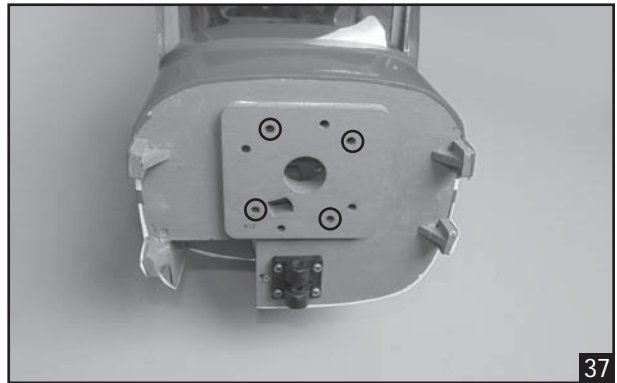

37

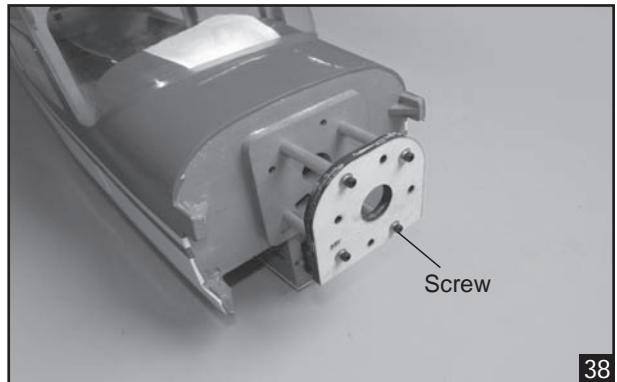

Screw

38

**INSTALLING THE MOTOR AND BATTERY**

Installing the electric motor

This model can fly with electric, here is our recommended for set up the system.

- Motor: RIMFIRE 1.20 (not included)
- Lipo cell: 6 cells / 5500 – 6000mAh (not included)
- Esc: 80A (not included)

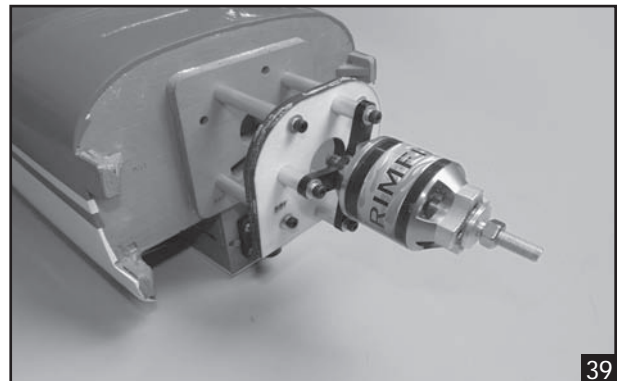

39

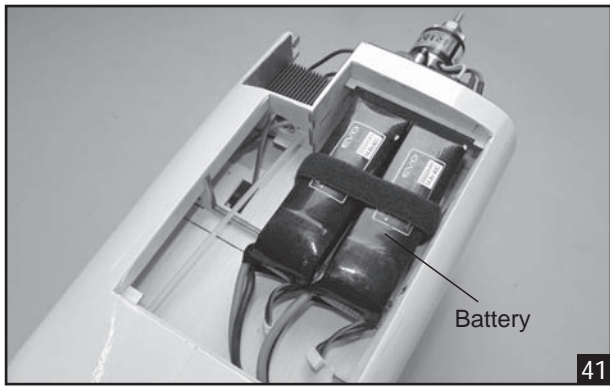
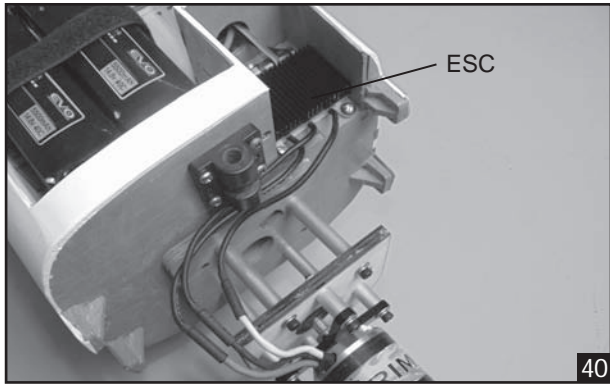

**ENGINE INSTALLATION**

**INSTALLING THE THROTTLE PUSHROD HOUSING**

1. Install the engine mount into the fire wall using 4mm x 25mm screw.
2. Place the engine into the engine mount and align it properly with the front of the cowling. The distance from the firewall to the front of the engine thrust washer should 145mm.

 *If your engine is equipped with a remote needle valve, we suggest installing it into the engine at this time.*

3. Slide the pushrod housing through the hole in the firewall, through the hole in the forward bulkhead, and into the servo compartment.
4. Apply a couple of drops of thin C/A to the pushrod housing where it exits the firewall and where it passes through the forward bulkhead. This will secure the housing in place.
5. Using a modeling knife, cut off the nylon pushrod housing 26mm in front of the servo tray.

**FUEL TANK INSTALLATION**

**INSTALLING THE STOPPER ASSEMBLY**

1. The stopper has been pre-assembled at the factory.
2. Using a modeling knife, cut one length of silicon fuel line (the length of silicon fuel line is calculated by how the weighted clunk should rest about 5mm away from the rear of the tank and move freely inside the tank). Connect one end of the line to the weighted clunk and the other end to the nylon pick up tube in the stopper.
3. Carefully bend the second nylon tube up at a 45 degree angle (using a cigarette lighter). This tube will be the vent tube to the muffler.
4. Carefully bend the third nylon tube down at a 45 degree angle (using a cigarette lighter). This tube will be vent tube to the fueling valve.

 *When the stopper assembly is installed in the tank, the top of the vent tube should rest just below the top surface of the tank. It should not touch the top of the tank.*

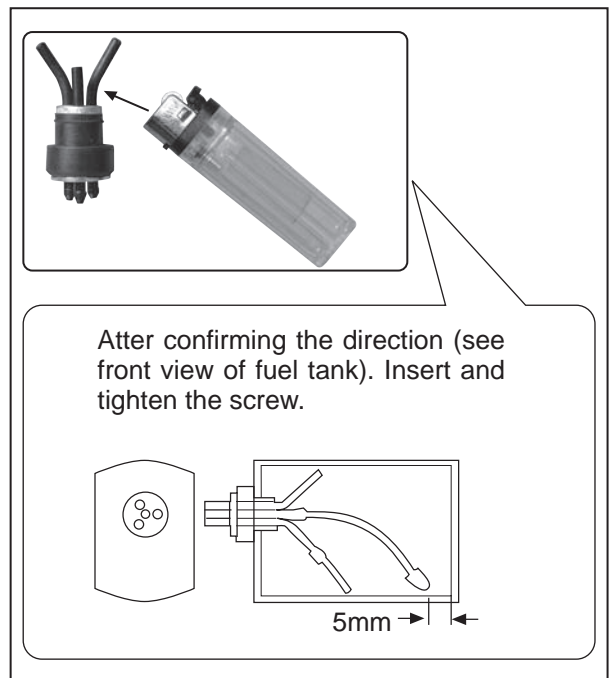

5. Test fit the stopper assembly into the tank. It may be necessary to remove some of the flashing around the tank opening using a modeling knife. If flashing is present, make sure none of it falls into the tank.
6. When satisfied with the alignment of the stopper assembly tighten the 3mm x 20mm machine screw until the rubber stopper expands and seals the tank opening. Do not over tighten the assembly as this could cause the tank to split.
7. Using a modeling knife, cut 3 lengths of fuel line . Connect 2 lines to the 2 vent tubes and 1 line to the fuel pickup tube in the stopper.

8. Feed three lines through the fuel tank compartment and through the pre-drilled hole in the firewall. Pull the lines out from behind the engine, while guiding the fuel tank into place. Push the fuel tank as far forward as possible, the front of the tank should just about touch the back of the firewall.

Blow through one of the lines to ensure the fuel lines have not become kinked inside the fuel tank compartment. Air should flow through easily.

 *Do not secure the tank into place permanently until after balancing the airplane. You may need to remove the tank to mount the battery in the fuel tank compartment.*

9. Secure the fuel tank using the plate of plywood and glue it by C.A glue.

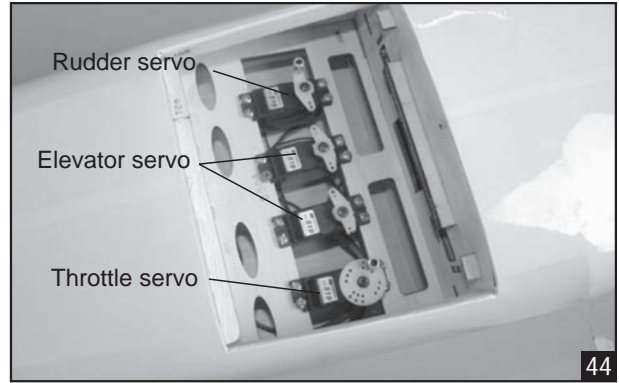
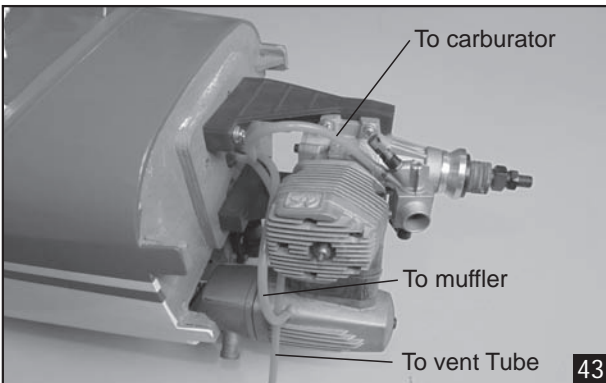

### **INSTALLING THE ELEVATOR PUSHROD**

1. Locate the pushrod exit slot on the right side and left side of the fuselage. It is located slightly ahead and below the horizontal stabilizer.
2. Carefully cut away the covering material from the slot.
3. Working from inside the fuselage, slide the threaded end of the pushrod until it reaches the exit slot. Carefully reach in with a small screw driver and guide the pushrod out of the exit slot.
4. Install the clevis on the elevator pushrod. Make sure 6mm of thread shows inside the clevis.
5. The control horn should be mounted on the bottom, left side and right side of the elevator at the leading edge, in line with the elevator pushrod.

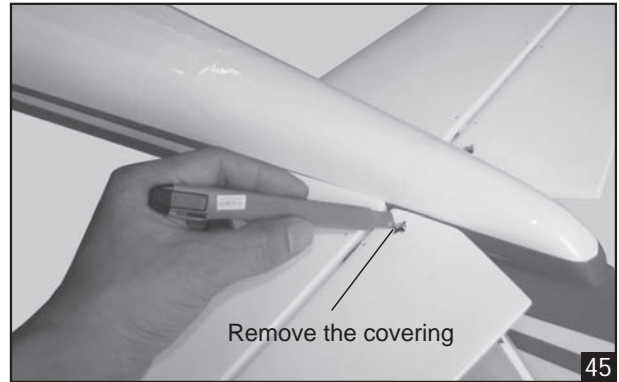

## **SERVO INSTALLATION**

### **INSTALLING THE FUSELAGE SERVOS**

1. Install the rubber grommets and brass collets into the elevator, rudder and throttle servos. Test fit the servos into the servo tray. Trim the tray if necessary to fit your servos
2. Mount the servos to the tray using the mounting screws provided with your radio system.

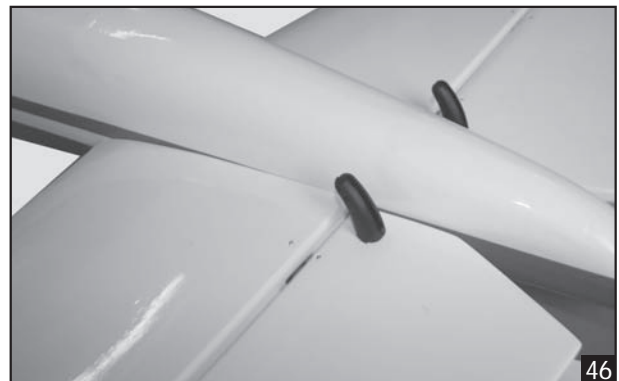

6. Attach clevis to the control horn.
7. Locate one nylon servo arm, and using wire cutters, remove all but one of the arms. Using a 2mm drill bit, enlarge the third hole out from the center to accommodate the elevator pushrod wire.
8. Plug the elevator servo into the receiver and center the servo. Install the servo arm onto the servo. The servo arm should be perpendicular to the servo and point toward the middle of the fuselage.
9. With the elevator and elevator servo centered, carefully place a mark on the elevator pushrod wire where it crosses the hole in the servo arm.
10. Using pliers, carefully make a 90 degree bend up at the mark made. Cut off the excess wire, leaving about 8mm beyond the bend.
11. Insert the 90 degree bend up through the hole in the servo arm, install one nylon snap keeper over the wire to secure it to the arm. Install the servo arm retaining screw and remove the masking tape the elevator halves.
12. Using thick CA glue, secure the pushrod sleeves to the pushrod sleeve guide.
13. Repeat these step for installing the second elevator.

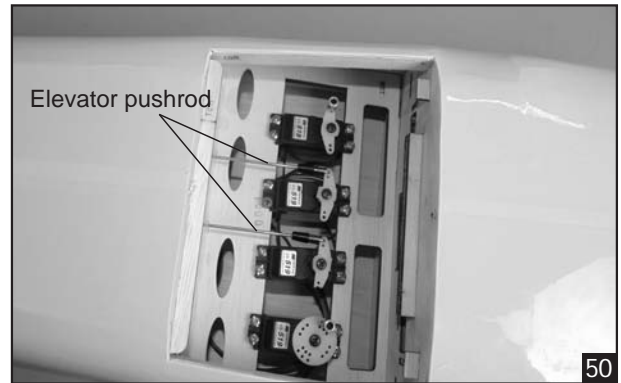

### **INSTALLING THE RUDDER PUSHROD**

1. Locate the pushrod exit slot on the left of the fuselage.
2. Carefully cut away the covering material from the slot.
3. Working from inside the fuselage, slide the threaded end of the remaining pushrod down the inside of the fuselage until the pushrod reaches the exit slot. Carefully reach in with a small screw driver and guide the pushrod out of the exit slot.
4. Install the clevis on the rudder pushrod. Make sure 6mm of thread shows inside the clevis.
5. The control horn should be mounted on the left side of the rudder at the leading edge, in line with the rudder pushrod.

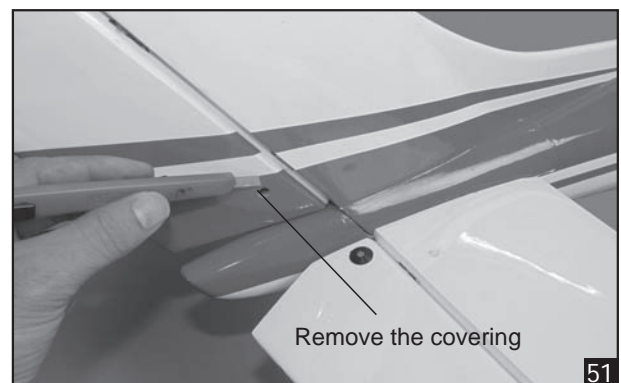



6. Attach clevis to the control horn.
7. Locate one nylon servo arm, and using wire cutters, remove all but one of the arms using a 2mm drill bit, enlarge the third hole out from the center to accommodate the rudder pushrod wire.
8. Plug the rudder servo into the receiver and center the servo. Install the servo arm onto the servo.
9. Center the rudder and hold it in place using a piece of masking tape.
10. With the rudder and rudder servo centered, carefully place a mark on the rudder pushrod wire where it crosses the hole in the servo arm.
11. Using a pliers, carefully make a 90 degree bend up at the mark made. Cut off excess wire, leaving about 8mm beyond the bend.
12. Insert the 90 degree bend up through the hole in the servo arm. Install one nylon snap keeper over the wire to secure it to the arm. Install the servo arm retaining screw and remove the masking tape from the rudder.
13. Using thick CA glue, secure the pushrod sleeves to the pushrod sleeve guide.

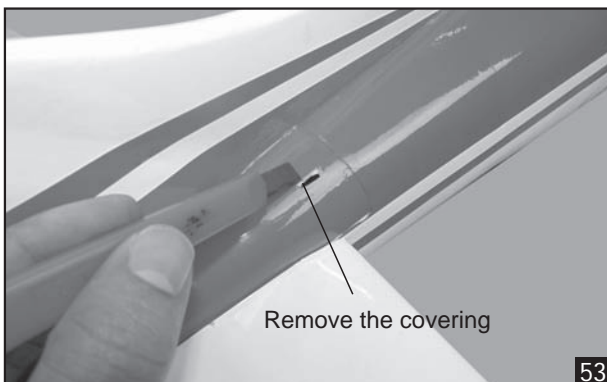
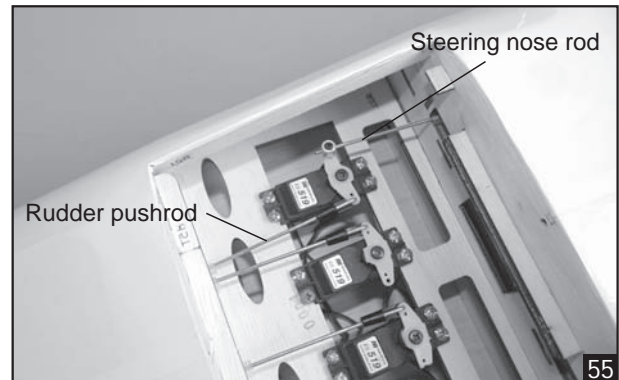
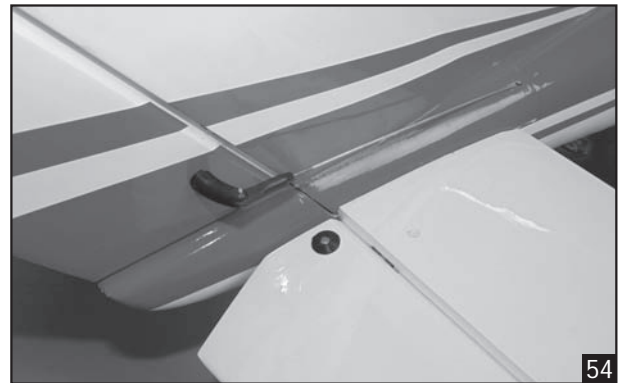

## INSTALLING THE THROTTLE

1. Install one adjustable metal connector through the third hole out from the center of one servo arm, enlarge the hole in the servo arm using a 2mm drill bit to accommodate the servo connector. Remove the excess material from the arm.

 After installing the adjustable metal connector apply a small drop of thin C/A to the bottom nut. This will prevent the connector from loosening during flight.

2. Plug the throttle servo into the receiver and turn on the radio system. Check to ensure that the throttle servo output shaft is moving in the correct direction. When the throttle stick is moved forward from idle to full throttle, the throttle barrel should also open and close using this motion. If not, reverse the direction of the servo, using the transmitter.
3. Slide the adjustable metal connector / servo arm assembly over the plain end of the pushrod wire. Position the throttle stick and the throttle trim at their lowest positions.
4. Manually push the carburetor barrel fully closed. Angle the arm back about 45 degree from center and attach the servo arm onto the servo. With the carburetor barrel fully closed, tighten the set screw in the adjustable metal connector.
5. Remove the excess throttle pushrod wire using wire cutters and install the servo arm retaining screw.

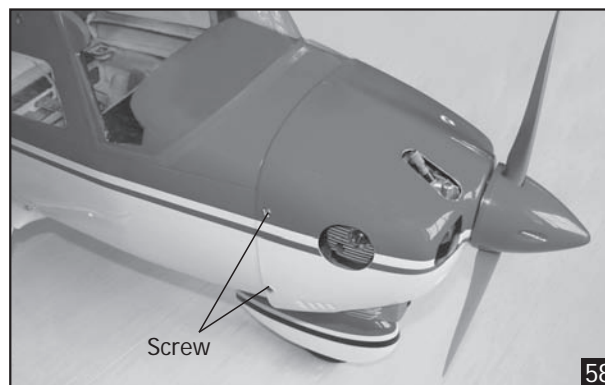
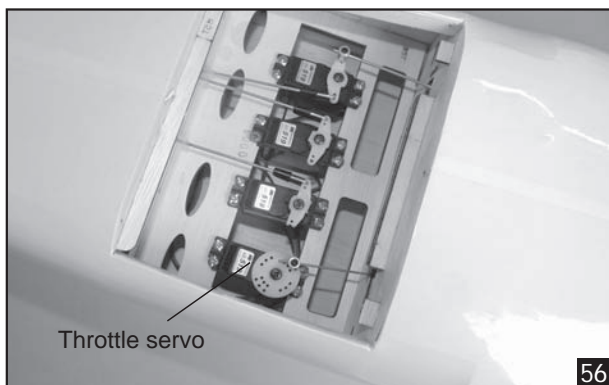

### **MOUNTING THE COWL**

1. Remove the muffler and needle valve assembly from the engine. Slide the fiberglass cowl over the engine.
2. Measure and mark the locations to be cut out for engine head clearance, needle valve, muffler. Remove the cowl and make these cutouts using a rotary tool with a cutting disc and a rotary sanding drum attachment.
3. Slide the cowl back into place. Align the front of the cowl with the crankshaft of the engine. The front of the cowl should be positioned so the crankshaft is in the middle of the precut opening. Hold the cowl firmly in place using several pieces of masking tape.
4. While holding the cowl firmly in position, drill four 1,6mm pilot holes through both the cowl and the side edges of the firewall.
5. Using a 3mm drill bit, enlarge the four holes in the cowling.

 *Enlarging the holes through the cowl will prevent the fiberglass from splitting when the mounting screws are installed.*

6. Slide the cowl back over the engine and secure it in place using four 3mm x 12mm wood screws.
7. Install the muffler. Connect the fuel and pressure lines to the carburator, muffler and fuel filler valve. Tighten the screws completely.

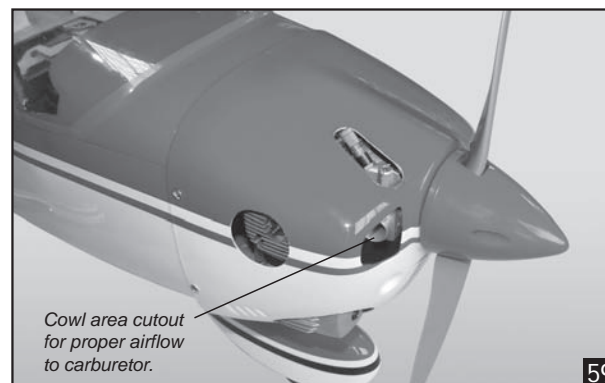

### **FINAL ASSEMBLY**

#### **INSTALLING THE SPINNER**

Install the spinner back-plate, propeller and spinner cone.

 *The propeller should not touch any part of the spinner cone. If it does, use a sharp modeling knife and carefully trim away the spinner cone where the propeller comes in contact with it.*

#### **INSTALLING THE RECEIVER AND BATTERY**

1. Plug the servo leads and the switch lead into the receiver. You may want to plug an aileron extension into the receiver to make plugging in the aileron servo lead easier when you are installing the wing. Plug the battery pack lead into the switch.
2. Wrap the receiver and battery pack in the protective foam to protect them from vibration. Use a rubber band or masking tape to hold the foam in place.

 *Do not permanently secure the receiver and battery until after balancing the model.*

3. Using a 2mm drill bit, drill a hole through the side of the fuselage, near the receiver, for the antenna to exit.

**INSTALLING THE SWITCH**

1. The switch should be mounted on the fuselage side, opposite the muffler, close enough to the receiver so the lead will reach. Use the face plate of the switch cut out and locate the mounting holes.
2. Cut out the switch hole using a modeling knife. Use a 2mm drill bit and drill out the two mounting holes through the fuselage side.
3. Secure the switch in place using the two machine screws provided with the radio system.

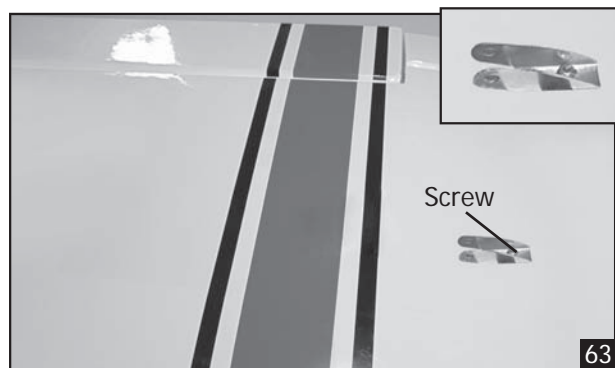
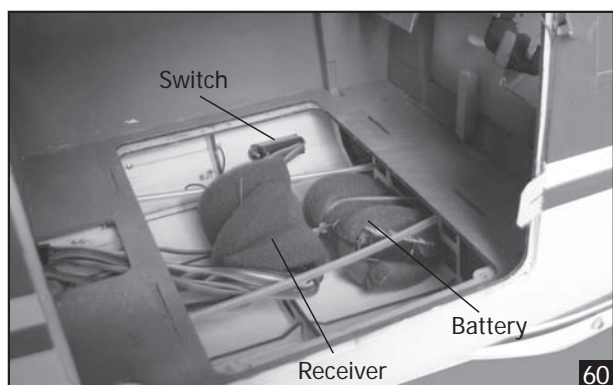

- Attach the wing strut to the fuselage.

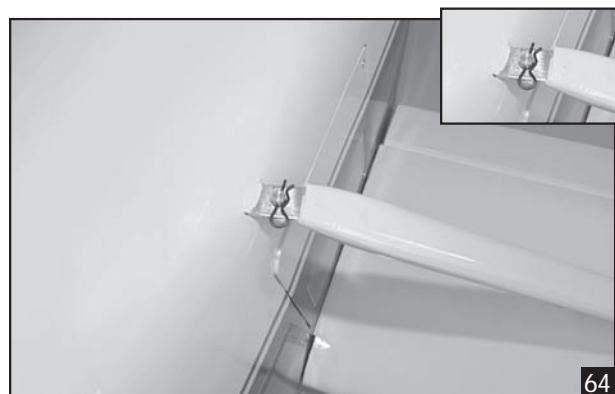

**INSTALLING THE WING STRUT**

- The wing strut was installed as the picture below.

- Secure the wing strut to the metal strap.

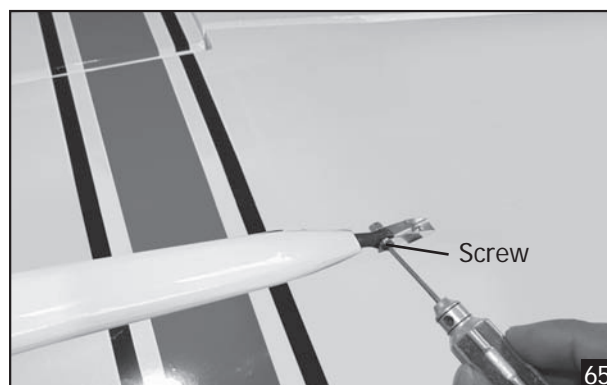

- Secure the metal strap to the wing as photo below.

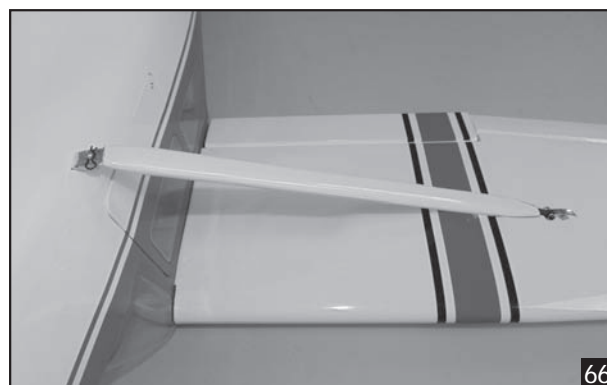
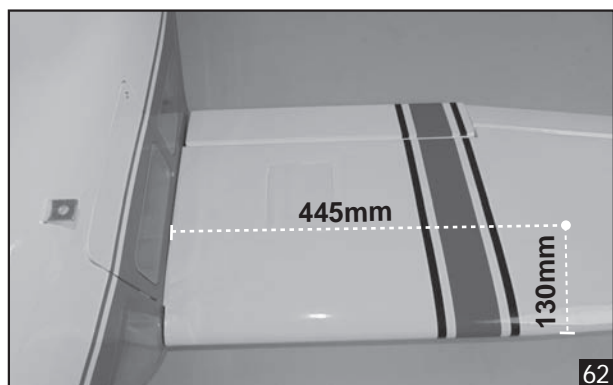

- Glue the plastic part.

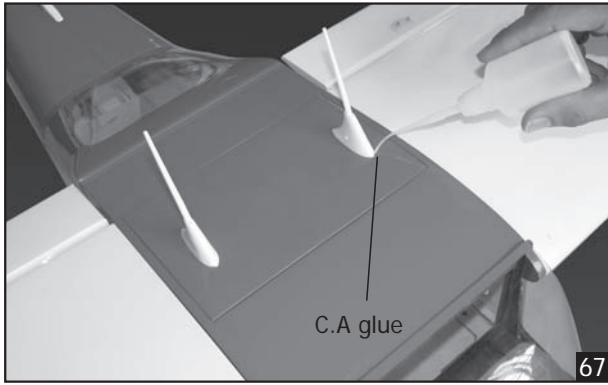

**INSTALLING THE PILOT**

1. Do not glue the pilot because the pilot must be remove when changing the battery.

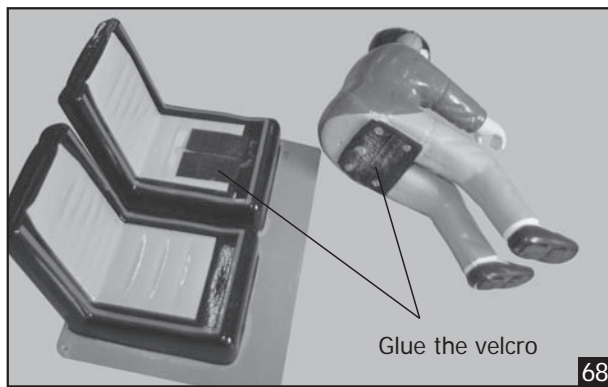

2. Glue the velcro to the pilot and chair

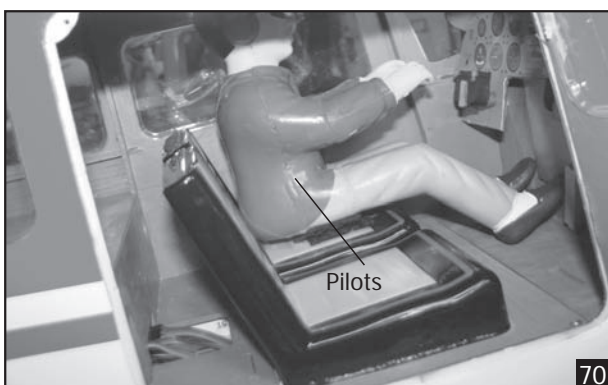
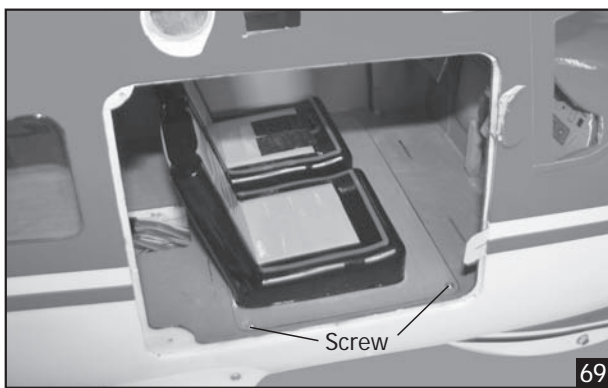

**INSTALLING THE DOOR**

1. Glue the velcro to the panel.

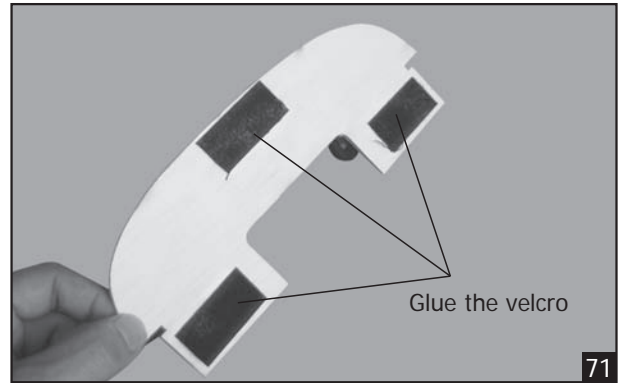

2. Attach the panel to the plate.

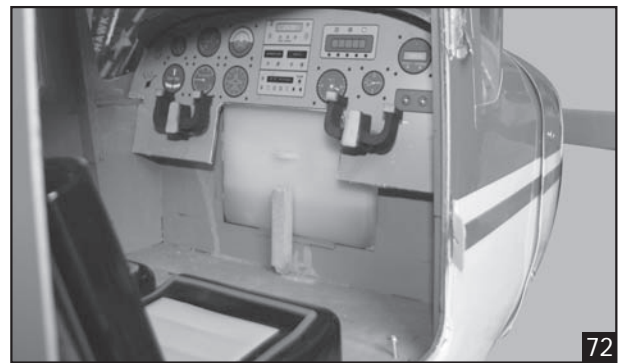

3. Install the door using C.A glue.

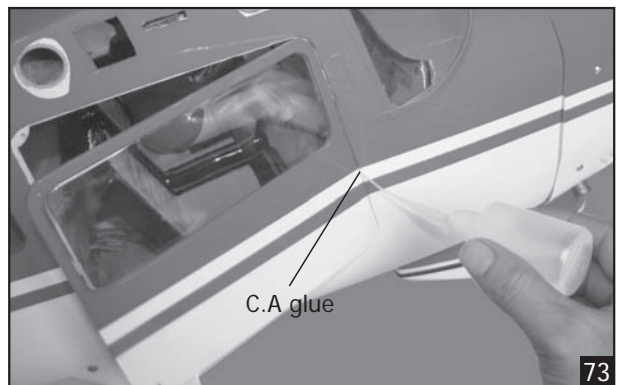

4. Screw the door.

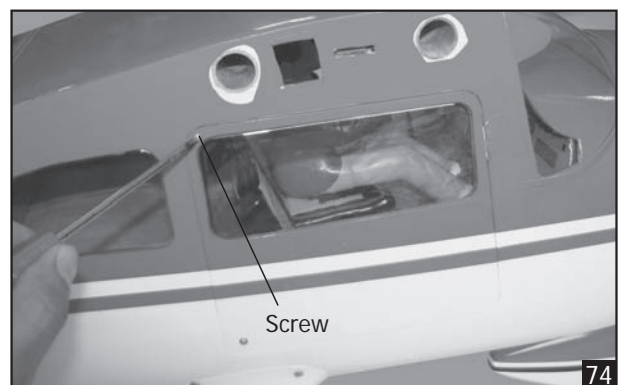

**BALANCING**

1. It is critical that your airplane be balanced correctly. Improper balance will cause your plane to lose control and crash.

THE CENTER OF GRAVITY IS LOCATED 85mm (3.3 in) BACK FROM THE LEADING EDGE OF THE WING, AT THE FUSELAGE.

2. Mount the wing to the fuselage. Using a couple of pieces of masking tape, place them on the top side of the wing 85mm (3.3 in) back from the leading edge, at the fuselage sides.

3. If the nose of the plane falls, the plane is heavy nose. To correct this first move the battery pack further back in the fuselage. If this is not possible or does not correct it, stick small amounts of lead weight on the fuselage under the horizontal stabilizer. If the tail of the plane falls, the plane is tail heavy. To correct this, move the battery and receiver forward or if this is not possible, stick weight into the firewall. When balanced correctly, the airplane should sit level or slightly nose down when you lift it up with your fingers.
4. We flew this model with OS 120 AX and the weight for take off is 5,8 kg.

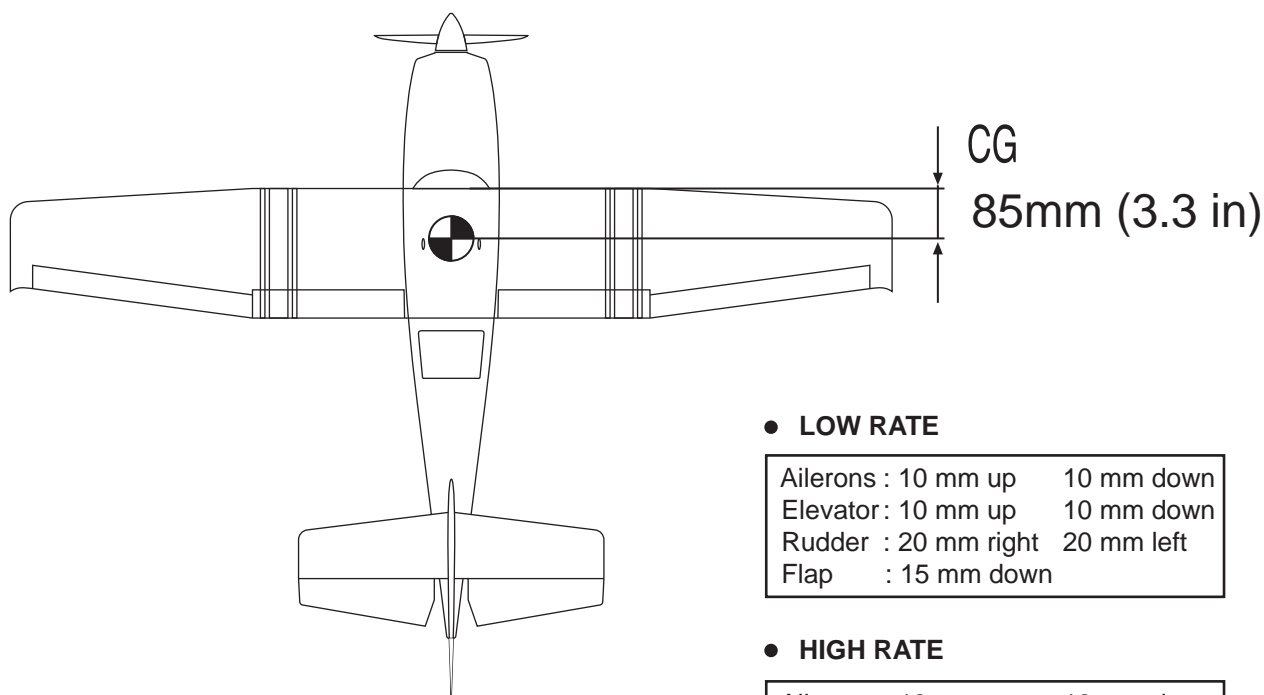

**LATERAL BALANCE**

 After you have balanced a plane on the C.G. You should laterally balance it. Doing this will help the airplane track straighter.

1. Turn the airplane upside down. Attach one loop of heavy string to the engine crankshaft and one to the tail wheel wire. With the wings level, carefully lift the airplane by the string. This may require two people to make it easier.
2. If one side of the wing fall, that side is heavier than the opposite. Add small amounts of lead weight to the bottom side of the lighter wing half's wing tip. Follow this procedure until the wing stays level when you lift the airplane.

● **LOW RATE**

Ailerons :	10 mm up	10 mm down
Elevator :	10 mm up	10 mm down
Rudder :	20 mm right	20 mm left
Flap :	15 mm down	

● **HIGH RATE**

Ailerons :	13 mm up	13 mm down
Elevator :	13 mm up	13 mm down
Rudder :	30 mm right	30 mm left
Flap :	20 mm down	

**CONTROL THROWS**

1. We highly recommend setting up a plane using the control throws listed.
2. The control throws should be measured at the widest point of each control surface.
3. Check to be sure the control surfaces move in the correct directions.

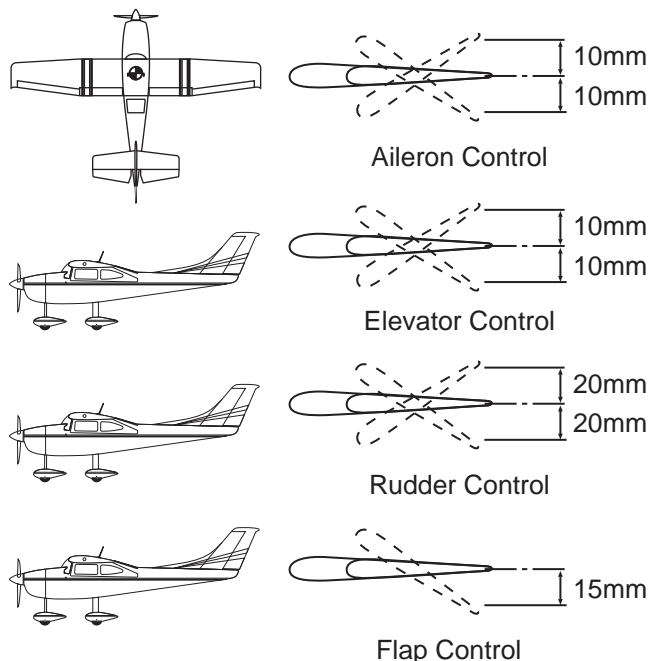

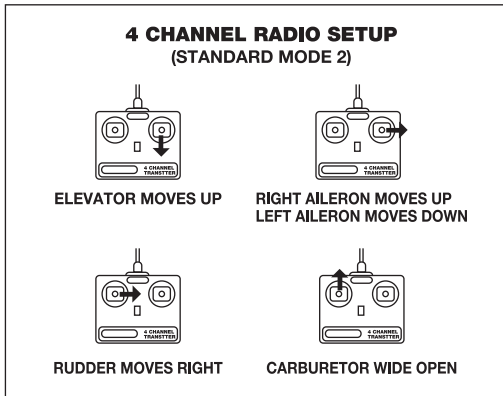

**FLIGHT PREPARATION PRE FLIGHT CHECK**

1. Completely charge your transmitter and receiver batteries before your first day of flying.
2. Check every bolt and every glue joint in your plane to ensure that everything is tight and well bonded.
3. Double check the balance of the airplane.
4. Check the control surface.
5. Check the receiver antenna. It should be fully extended and not coiled up inside the fuselage.
6. Properly balance the propeller.

**FOR YOUR RADIO INSTALLATION**  
**BASIC CONNECTION FOR AIRPLANE AND ADJUSTMENT OF SERVOS**

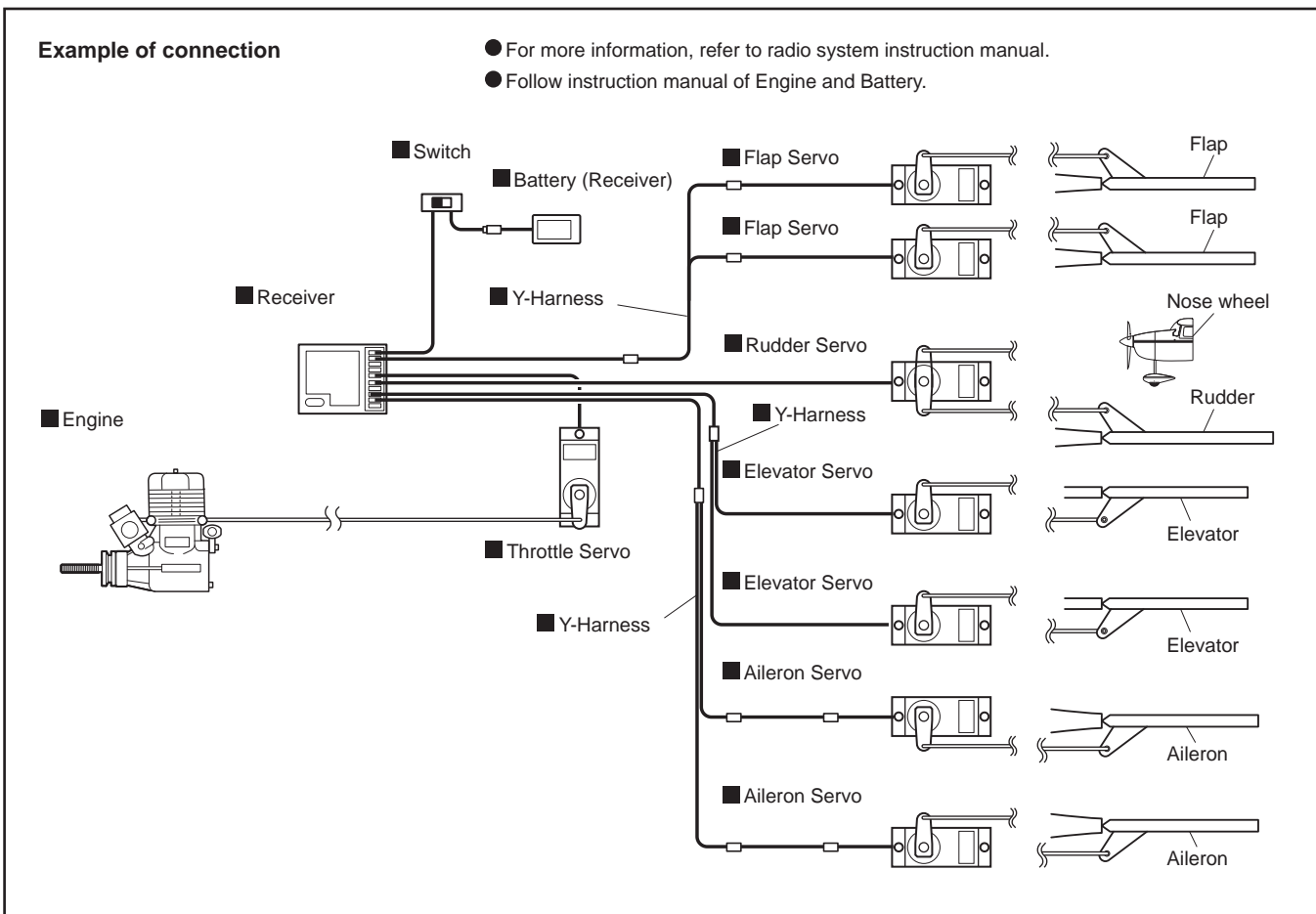

# I/C FLIGHT WARNINGS



Always operate in open areas, away from factories, hospitals, schools, buildings and houses etc. **NEVER** fly your aircraft close to people or built up areas.

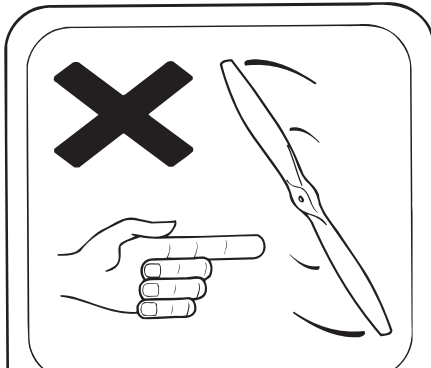

**THE PROPELLER IS DANGEROUS**  
Keep fingers, clothing (ties, shirt sleeves, scarves) or any other loose objects that could be caught or drawn in, away from the propeller. Take care at **ALL** times.

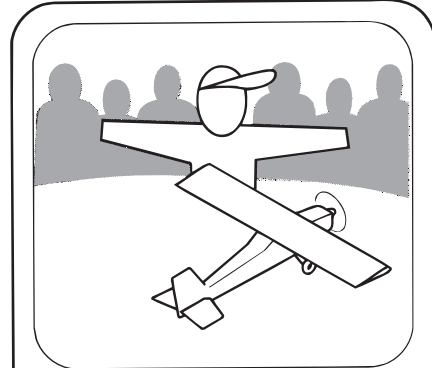

Keep all onlookers (especially small children and animals) well back from the area of operation. This is a flying aircraft, which will cause serious injury in case of impact with a person or animal.



**NEVER** fly near power lines, aerials or other dangerous areas including airports, motorways etc.

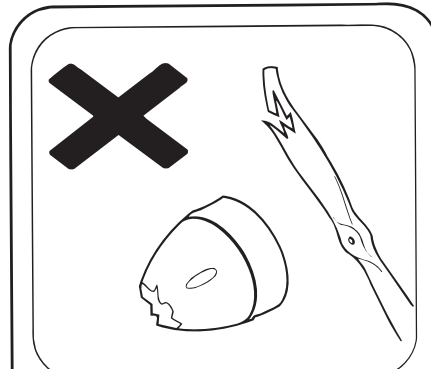

**NEVER** use damaged or deformed propellers or spinners.

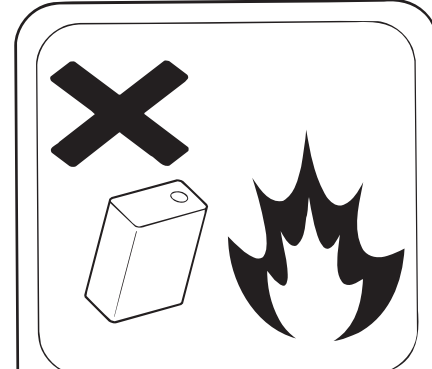

**DO NOT** dispose of empty fuel containers on a fire, this can lead to an explosion.

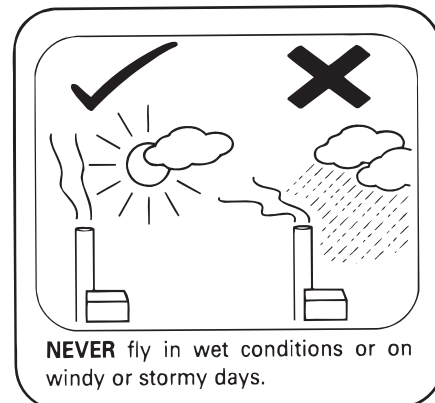

**NEVER** fly in wet conditions or on windy or stormy days.

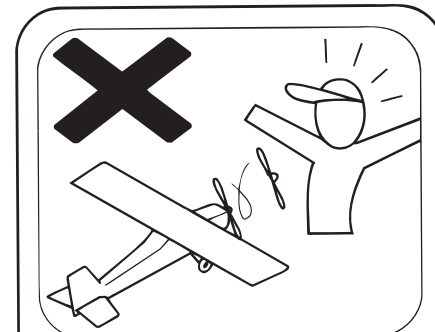

**ALWAYS** adjust the engine from behind the propeller, and do not allow any part of your body to be in line with the propeller.

# I/C FLIGHT GUIDELINES

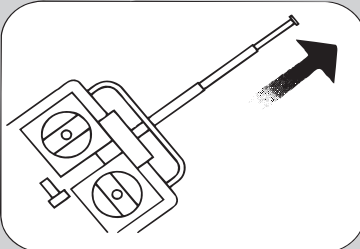

When ready to fly, first extend the transmitter aerial.

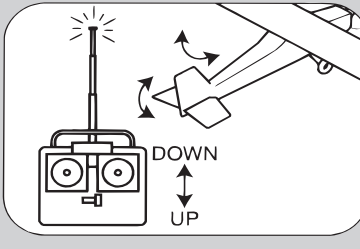

Operate the control sticks on the transmitter and check that the control surfaces move freely and in the **CORRECT** directions.

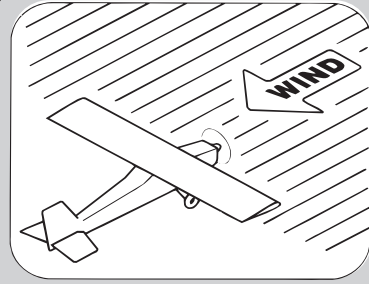

**ALWAYS** land the model **INTO** the wind, this ensures that the model lands at the slowest possible speed.

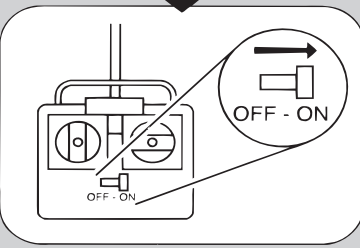

Switch on the transmitter.

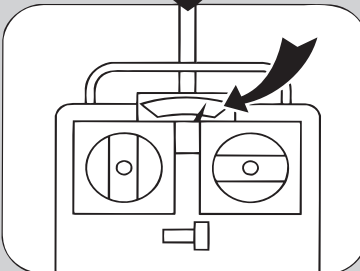

Check that the transmitter batteries have adequate power.

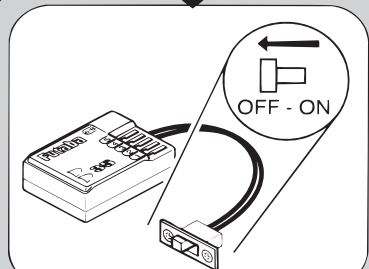

Switch off the receiver.

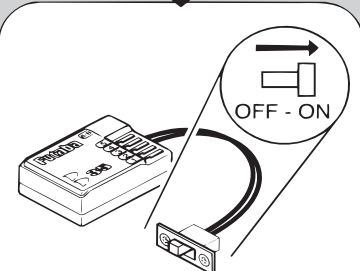

Switch on the receiver.



**ALWAYS** take off into the wind.

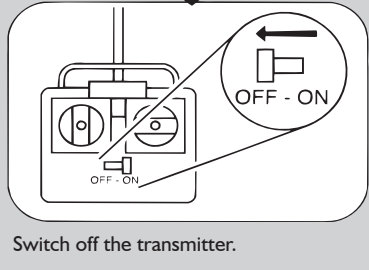

Switch off the transmitter.

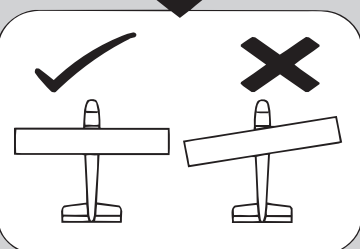

Check that the wings are correctly fitted to the fuselage.

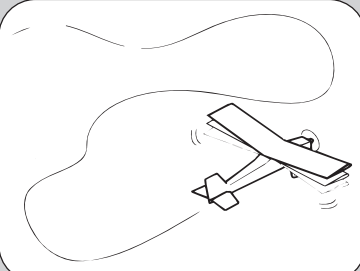

If the model does not respond correctly to the controls, land it as soon as possible and correct the fault.

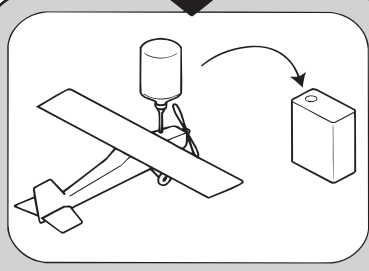

Empty the fuel tank after flying, fuel left in the tank can cause corrosion and lead to engine problems.