

CHAPTER 11

MAIN TANK



Tank.....	11-2
Tank Sump Fittings	11-3
Sump Drain.....	11-4
Sump Drain Hose Valve.....	11-4
Supermix Agitator.....	11-5
Tank Top Fittings.....	11-6
Tank Flush Nozzle (Elbow).....	11-7
Tank Flush Nozzle (Tee).....	11-7
Venturi.....	11-8
Hopper Inlet.....	11-8
Tank Fill.....	11-9
Sight Tube	11-9
Tank Straps	11-10
Tank Stops.....	11-10

Rev 00 27/8/09

TANK



Item	Part No	Description
A	GA5018515	3000L Bare Prairie Special Tank

TANK SUMP FITTINGS

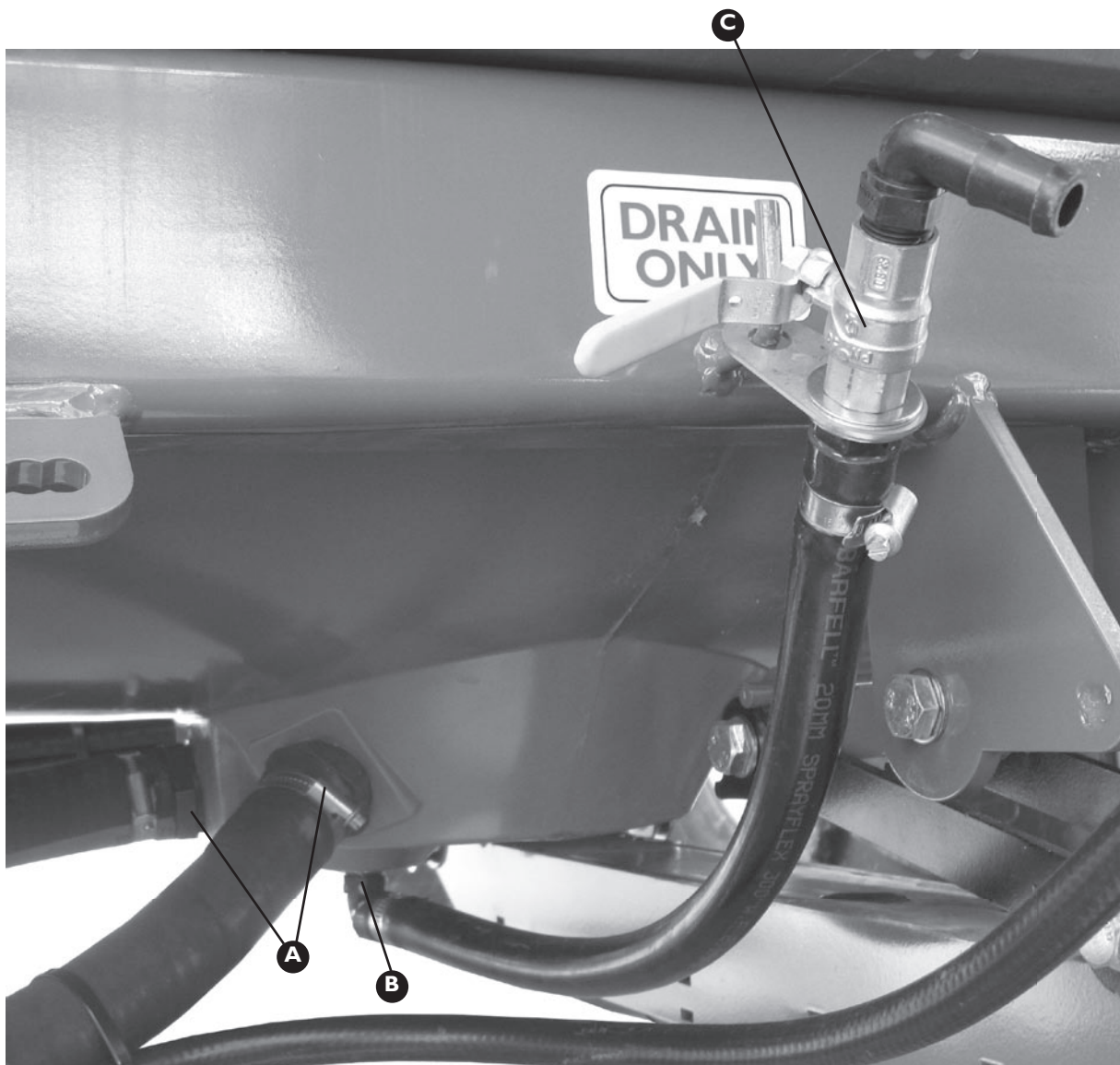

Item	Part No	Description	Quantity
A	HB150	1 1/2" Hose Barb	2
B	HB075-90	3/4" Poly Elbow	1
C	GA4903097	Sump Drain Hose Valve*	1

* Refer to next page

SUMP DRAIN

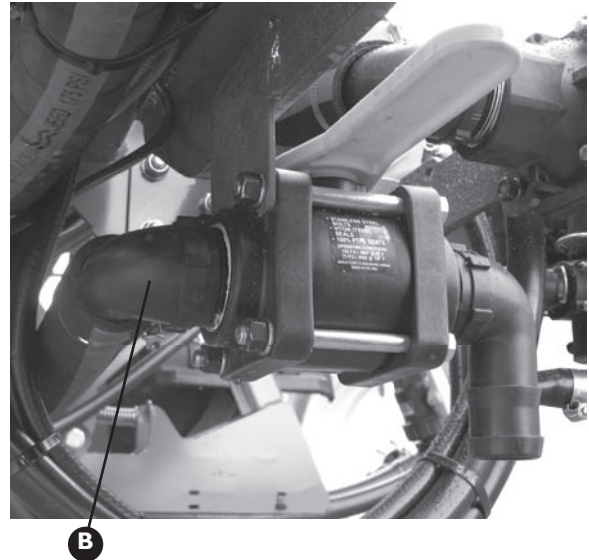

Assembly Part No GA4903063

Item	Part No	Description	Quantity
A	VI150	1 1/2" Ball Valve	1
B	HB150-90	1 1/2" Poly Elbow	2

SUMP DRAIN HOSE VALVE

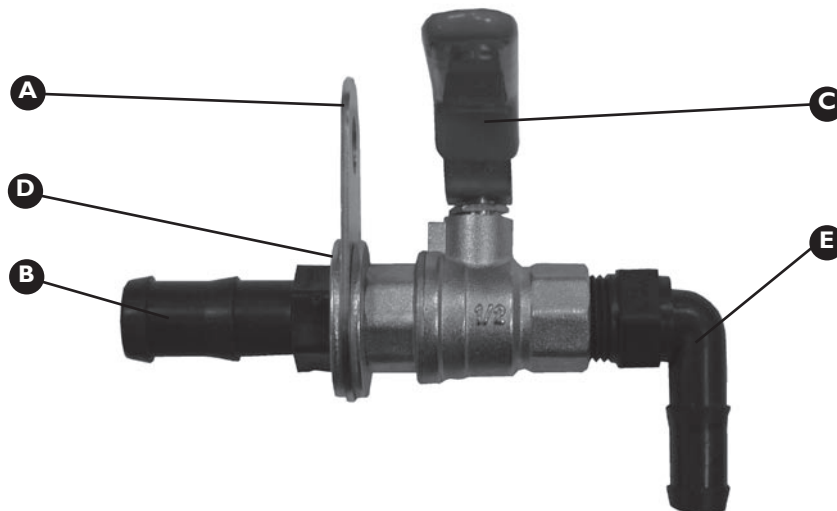

Assembly Part No. GA4903097

Item	Part No	Description	Quantity
A	F70565A	Stainless Steel Mounting Plate	1
B	HB050-075	1/2" x 3/4" Poly Hose Barb	1
C	GA5018309	Ball Valve	1

Item	Part No	Description	Quantity
D	GA5001741	20mm S/S Washer	2
E	HB050/075-90	1/2" x 3/4" Poly Elbow	1

SUPER MIX AGITATOR

Item	Part No	Description	Quantity
A	GA4903096	Super Mix Agitator Assembly	1
B	HB100-90	1" Poly Elbow	3
C	HB100	1" Hose Barb	1
D	TEE100	1" Female Tee	1

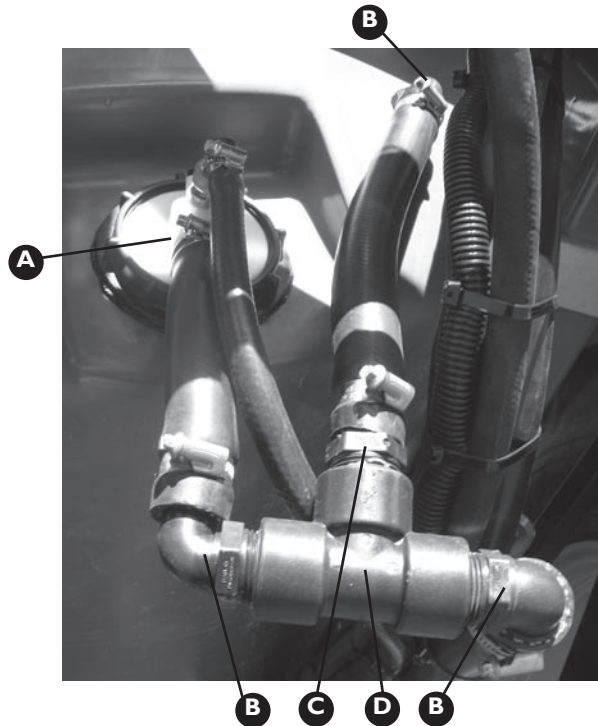

SUPER MIX AGITATOR ASSEMBLY

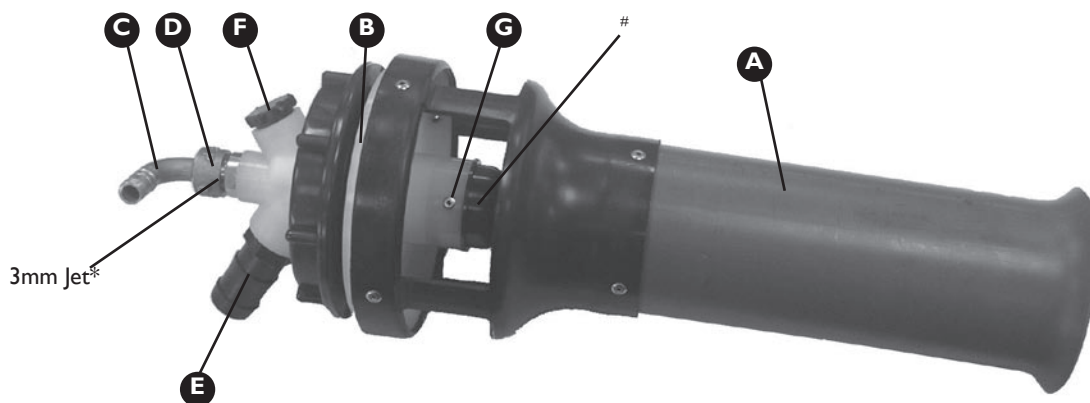

Assembly Part No GA4903096

Item	Part No	Description	Quantity
A	502054	Agitator Mixer Body	1
B	GA5020050	O-Ring M5 x 100mm	1
C	0065302	1/2" Brass Elbow	1
D	GA5012375	1/2" Nut with O-Ring	1

Item	Part No	Description	Quantity
E	HB075-100	3/4" x 1" Hose Barb	1
F	PLUG050	1/2" Plug	1
G	GA5005117	1/8" x 5/16" Pop Rivet	1

* Included in mixer body, # Blank venturi fitted standard other sizes available upon request

TANK TOP FITTINGS

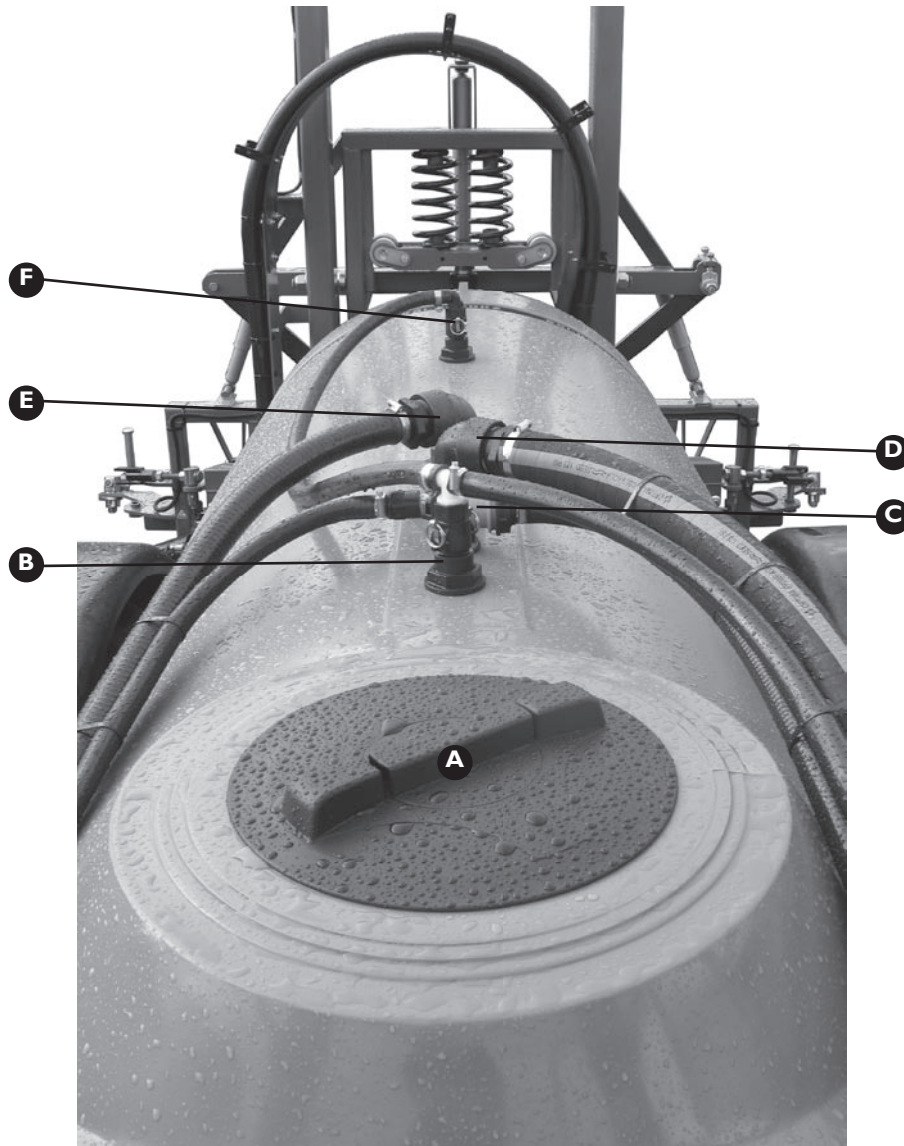

Item	Part No	Description	Quantity
A-1	352040	Tank Lid	1
A-2	300120	Basket Filter	1
B	GA4901285-2	Tank Rinse Nozzle (Tee)*	1
C	GA4903086	Venturi*	1
D	GA4903136	2" Tank Fill*	1
E	GA4903098	Hopper Inlet*	1
F	GA4901285-1	Tank Rinse Nozzle (Elbow)	1

* Component breakdowns shown on following pages

TANK FLUSH NOZZLE (ELBOW)

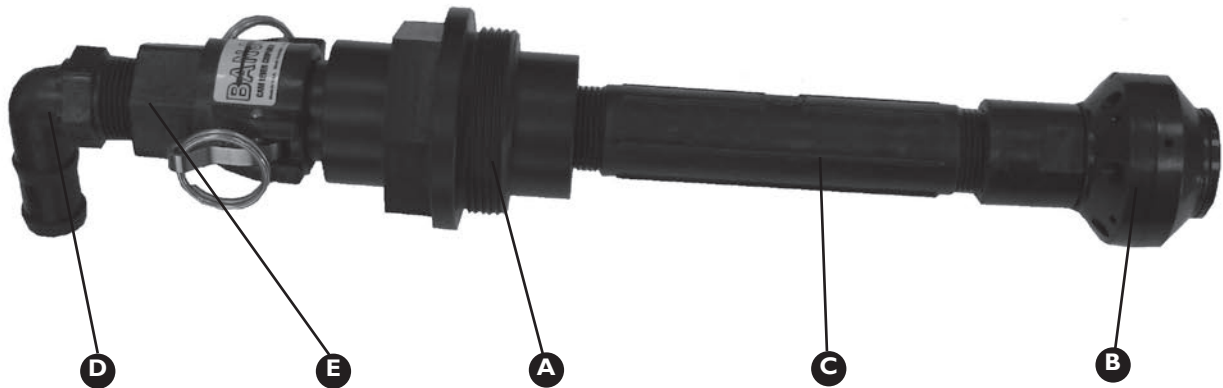

Assembly Part No. GA4901285-1

Item	Part No	Description	Quantity
A	GA4572015	Tank Adapter with Cam Lock	1
B	B55270-3/4-18	Rinse Nozzle	1
C	NIP075-6	3/4" x 6" Poly Nipple	1

Item	Part No	Description	Quantity
D	HB075-90	3/4" Poly Elbow	1
E	75D	3/4" Female Coupler	1

TANK FLUSH NOZZLE (TEE)

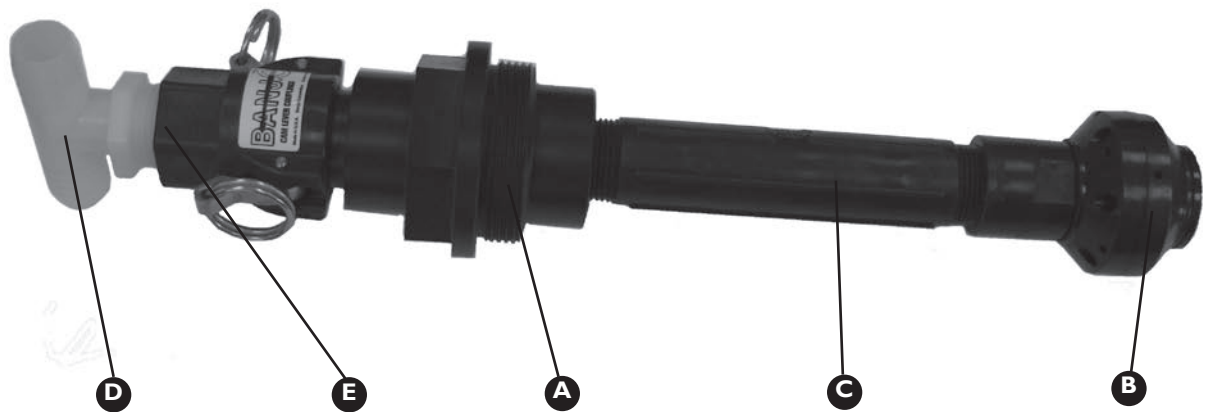

Assembly Part No. GA4901285-2

Item	Part No	Description	Quantity
A	GA4572015	Tank Adapter with Cam Lock	1
B	B55270-3/4-18	Rinse Nozzle	1
C	NIP075-6	3/4" x 6" Poly Nipple	1

Item	Part No	Description	Quantity
D	GA5018776	3/4" Poly Tee	1
E	75D	3/4" Female Coupler	1

VENTURI

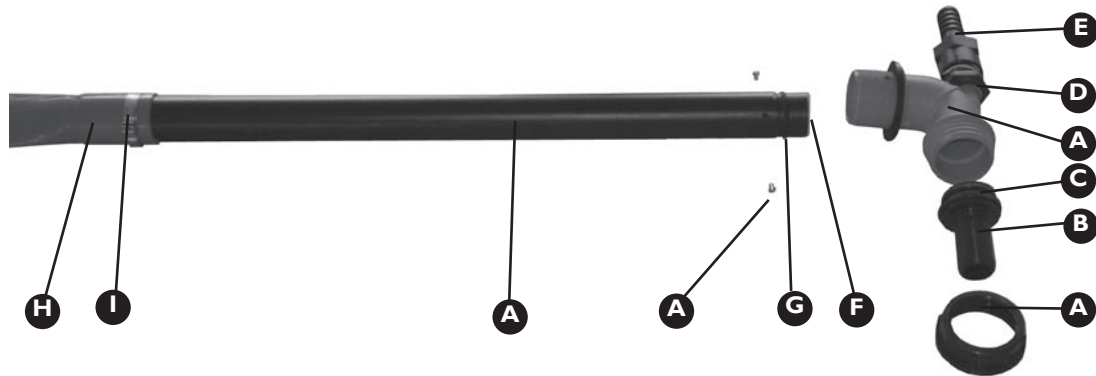

Assembly Part No. GA4903086

Item	Part No	Description	Quantity
A	500232	Venturi Filler	1
B	106625	1" Hose Tail	1
C	G10060	O-ring M3 x 29mm	1
D	RB075050	3/4" x 1/2" Poly Reducer Bush	1
E	HBF075	3/4" Female Hose Barb	1

Item	Part No	Description	Quantity
F	MACH0022	Venturi Jet	1
G	GA5049125	O-ring Imperial BS213	3
H	GA5050205	32mm Lay Flat Hose (blue) 0.405m	1
I	GA5007235	Cobra Clamp	1

HOPPER INLET

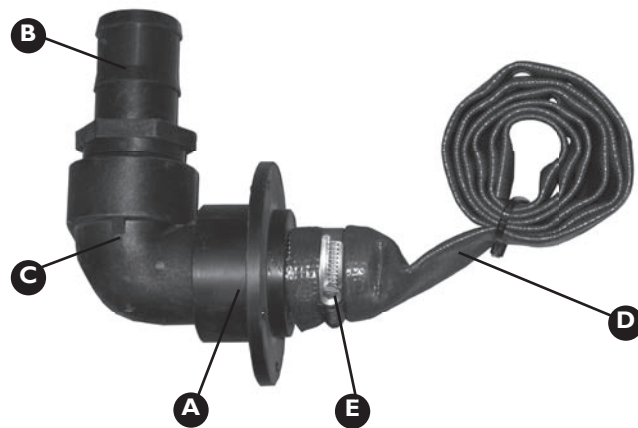

Assembly Part No. GA4903098

Item	Part No	Description	Quantity
A	L026A	Tank Flange	1
B	HB200-150	1 1/2" Straight Poly Hose Barb	1
C	SL200-90	2" Elbow	1

Item	Part No	Description	Quantity
D	HOS50PVC	50mm PVC Hose*	1.55m
E	GA5003325	Hose Clamp	1
F	GA5000529	1" x 12g Screw#	3

* Photo shows layflat hose which has now been replaced by PVC

Not shown in photo

TANK FILL

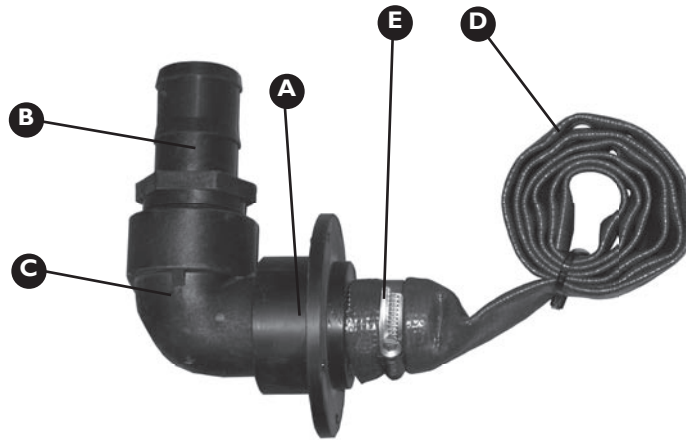

Assembly Part No. GA4903136

Item	Part No	Description	Quantity
A	L026A	Tank Flange	1
B	HB200	2" Straight Poly Hose Barb	1
C	SL200-90	2" Elbow	1

Item	Part No	Description	Quantity
D	HOS50PVC	50mm PVC Hose	1.55m
E	GA5003325	Hose Clamp	1
F	GA5000529	1" x 12g Screw#	3

* Photo shows layflat hose which has been replaced by PVC
 # Not shown in photo

SIGHT TUBE

Item	Part No	Description	Quantity
A-1	HB050-90	1/2" Poly Elbow	2
A-2	GA5007231	Cobra Clamp	2
B	HOS12sight	12mm Clear Sight Tube	1.1m*

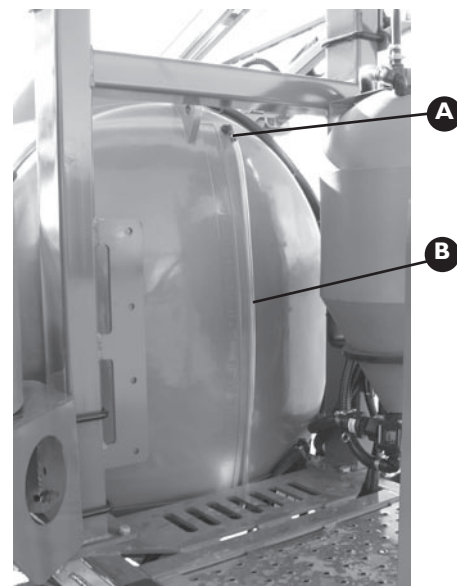

*This is only an approximate valve and a required amount should be specified when ordering

TANK STRAPS

Item	Part No	Description	Quantity
A	GA5003859	50mm Wide Tank Strap	8m*
B	F70127A	Tank Strap Mounting Bracket	4
C-1	GA5000331	M12 x 50mm Bolt	4
C-2	GA5012461	M12 Nyloc Nut	4
C-3	GA5000577	12mm Washer	4

*The required length needs to be specified when ordered as quantities may vary between machines. This value is an approximate value for the entire machine (front and back).

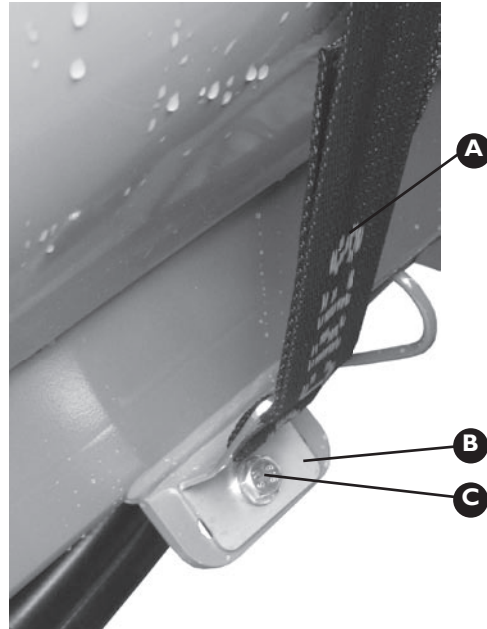

TANK STOPS

Item	Part No	Description	Quantity
A	F70295A	Tank Stop (Left)	1
	F70296A	Tank Stop (Right)	1
B	F70297A	Mounting Plate	1
C-1	GA5000277	M12 x 160mm Bolt	2
C-2	GA5012461	M12 Nyloc Nut	2
C-3	GA5000577	12mm Washer	4

