

1020.01 General	Exhibit 1020-1 Reflective Sheeting Requirements for Overhead Signs
1020.02 Design Components	
1020.03 Overhead Installation	Exhibit 1020-2 Timber Posts
1020.04 State Highway Route Numbers	Exhibit 1020-3 Wide Flange Steel Posts
1020.05 Mileposts	Exhibit 1020-4 Square Steel Posts
1020.06 Guide Sign Plan	
1020.07 Documentation	
1020.08 References	

1020.01 General

The Washington State Department of Transportation (WSDOT) uses signing as the primary mechanism for regulating, warning, and guiding traffic. Signing must be in place when any section of highway is open to the motoring public. Each highway project has unique and specific signing requirements. For statewide signing uniformity and continuity, it is sometimes necessary to provide signing beyond the project limits. Design characteristics of the facility determine the size and legend for a sign. As the design speed increases, larger sign sizes are necessary to provide adequate message comprehension time. The [MUTCD](#), the [Traffic Manual](#), and the [Sign Fabrication Manual](#) contain standard sign dimensions, specific legends, and reflective sheeting types for all new signs.

Guide signing provides the motorist with directional information to destinations. This information is always presented in a consistent manner. In some cases, there are specific laws, regulations, and policies governing the content of the messages on these signs. All proposed guide signs for a project require the approval of the region Traffic Engineer. The use of nonstandard signs is strongly discouraged and their use requires the approval of the State Traffic Engineer.

Apply the following criteria when determining whether to replace or modify existing signs:

- Current sign's service life is reached
- Lack of nighttime retroreflectivity
- Substantial damage, vandalism, or deterioration
- Replace existing signs with either Type I or Type II sheeting
- Change in sign use policy
- Improper location
- Message or destination changes necessary to satisfy commitments to public or local agencies
- Substandard mounting height
- Change in jurisdiction (for example, a county road becomes a state route)

Address sign support breakaway features in accordance with Chapter 1600.

1020.02 Design Components

1020.02(1) Location

The [MUTCD](#) contains the guidelines for positioning signs. Check sign locations to ensure the motorist's view of the sign is not obscured by other roadside appurtenances. Also, determine whether the proposed sign will obstruct the view of other signs or limit the motorist's sight distance of the roadway. Reposition existing signs, when necessary, to satisfy these visibility requirements. Where possible, locate signs behind existing traffic barriers, on grade separation structures, or where terrain features will minimize their exposure to errant vehicles.

1020.02(2) Longitudinal Placement

The [MUTCD](#) and the [Traffic Manual](#) provide guidelines for the longitudinal placement of signs that are dependent on the type of sign. Select a location to fit the existing conditions to provide for visibility and adequate response time. In most cases, signs can be shifted longitudinally to enhance safety without compromising their intended purpose.

1020.02(3) Lateral Clearance

The [Standard Plans](#) and the [MUTCD](#) contain minimum requirements for the lateral placement of signs. Where possible, position the signs at the maximum feasible lateral clearance for safety and reduced maintenance costs. Locate large guide signs and motorist information signs beyond the Design Clear Zone (see Chapter 1600) where limited right of way or other physical constraints are not a factor. On steep fill slopes, an errant vehicle is likely to be partially airborne from the slope break near the edge of shoulder to a point 12 feet down the slope. When signs are placed on fill slopes steeper than 6H:1V, locate the support at least 12 feet beyond the slope break.

Use breakaway sign support features, when required, for signs located within the Design Clear Zone and for signs located beyond this zone where there is a possibility they might be struck by an errant vehicle. Breakaway features are not necessary on signposts located behind traffic barriers. Install longitudinal barriers to shield signs without breakaway features within the Design Clear Zone when no other options are available.

Sign bridges and cantilever sign structures have limited span lengths. Locate the vertical components of these structures as far from the traveled way as possible and, where appropriate, install traffic barriers (see Chapter 1610).

Do not locate signposts in the bottom of a ditch or where the posts will straddle the ditch. The preferred location is beyond the ditch or on the ditch backslope (see the [Standard Plans](#)). In high-fill areas where conditions require placement of a sign behind a traffic barrier, consider adding embankment material to reduce the length of the sign supports.

1020.02(4) Sign Heights

For ground-mounted signs installed at the side of the road, provide a mounting height of at least 7 feet, measured from the bottom of the sign to the edge of traveled way. Supplemental plaques, when used, are mounted directly below the primary sign. At these locations, the minimum mounting height of the plaque is 5 feet.

Do not attach supplemental guide signs to the posts below the hinge mechanism or the saw cut notch on multiple-post installations. The location of these hinges or saw cuts on the sign supports are shown in the [Standard Plans](#).

A minimum 7-foot vertical height from the bottom of the sign to the ground directly below the sign is necessary for the breakaway features of the sign support to function properly when struck by a vehicle. The minimum mounting height for new signs located behind longitudinal barriers is 7 feet, measured from the bottom of the sign to the edge of traveled way. A lower mounting height of 5 feet may be used when replacing a sign panel on an existing sign assembly located behind the longitudinal barrier. The *Standard Plans* shows typical sign installations.

For ground-mounted signs installed on multiple posts that are a minimum of 12 feet from the edge of traveled way in cut sections, the minimum height clearance between the sign and the ground for the post farther from the edge of traveled way is as follows:

- For slopes 2H:1V and steeper, the minimum height clearance is 2 feet.
- For slopes 3H:1V or flatter, the minimum height clearance is 7 feet.

Signs used to reserve parking for people with disabilities are installed at each designated parking stall and are mounted 7 feet above the surface at the sign location.

1020.02(5) Foundations

Foundation details for timber and steel ground-mounted sign supports are shown in the *Standard Plans*, which also contains foundation designs for truss-type sign bridges and cantilever sign structures. Three designs, Types 1, 2, and 3, are shown for each structure.

An investigation of the foundation material is necessary to determine the appropriate foundation design. Use the data obtained from the geotechnical report to select the foundation type.

- The **Type 1** foundation design uses a large concrete shaft and is the preferred installation when the lateral bearing pressure of the soil is 2,500 psf or greater.
- The **Type 2** foundation design has a large rectangular footing design and is an alternative to the Type 1 foundation when the concrete shaft is not suitable.
- The **Type 3** foundation design is used in poorer soil conditions where the lateral bearing pressure of the soil is between 1,500 psf and 2,500 psf.

If a nonstandard foundation or monotube structure design is planned, forward the report to the Headquarters (HQ) Bridge and Structures Office for use in developing a suitable foundation design (see Chapter 610).

1020.02(6) Signposts

Ground-mounted signs are installed on either timber posts or steel posts. The size and number of posts required for a sign installation are based on the height and surface area of the sign, or signs, being supported. Use the information in Exhibit 1020-2,

Exhibit 1020-3, and Exhibit 1020-4 and the *Standard Plans* to determine the posts required for each installation. Coordinate with the region Maintenance Office concerning signpost installation.

Use steel posts with breakaway supports that are multidirectional if the support is likely to be hit from more than one direction. For any wide flange multiple-steel post installations located within the Design Clear Zone, the total weight of all the posts in a 7-foot-wide path is not to exceed a combined post weight of 34 lbs/foot. Use the Wide Flange Beam Weights table in

Exhibit 1020-3 to determine wide flange steel post weights. If the proposed sign configuration does not meet the weight criterion, relocate, resize, or provide barrier protection for the proposed installation.

All signposts are to be designed to 90 mph wind loads. Design features of breakaway supports are shown in the [Standard Plans](#). Steel signposts commonly used are: Perforated Square Steel Tube (PSST); Square Steel Tube (SST); Round Pipe (RP); and Wide Flange "H-Beam." Steel posts with Type TP-A, TP-B, PL, PL-T, PL-U, AS, AP, SB-1, and SB-2 bases have multidirectional breakaway features.

1020.03 Overhead Installation

Guidance on the use of overhead sign installations is provided in the [MUTCD](#). Where possible, mount overhead signs on grade separation structures rather than sign bridges or cantilever supports.

Details for the construction of truss-type sign bridges and cantilever sign supports are shown in the [Standard Plans](#). The HQ Bridge and Structures Office designs structure-mounted sign mountings, monotube sign bridges, and monotube cantilever sign supports. For overhead sign installation designs, provide sign dimensions, horizontal location in relation to the roadway, and location of the lighting fixtures to facilitate design of the mounting components by the HQ Bridge and Structures Office. Provide existing and proposed sign dimensions to the Bridge Preservation Office for review when replacing or modifying any overhead sign.

1020.03(1) Illumination

The retroreflectivity of currently approved sign sheeting removes the need to provide illumination for sign installations.

Sign lights for existing illuminated overhead and ground-mounted signs can be de-energized and removed when the retroreflective sheeting is adequate for nighttime legibility, or the existing sign is replaced with a new sign (see Exhibit 1020-1 for sheeting requirements). A nighttime assessment of all nonilluminated overhead signs within the project limits is required (contact the Region Traffic Office). Replace all signs that have inadequate retroreflectivity. In situations where a nonhighway light source interferes with a sign's legibility, consider relocating the sign.

Where a new overhead sign is being installed adjacent to an existing sign with sign lights, all other signs on the structure shall be replaced unless they meet current sheeting requirements (see Exhibit 1020-1). The existing sign lights shall then be de-energized by physical disconnection of the sign lighting wiring from the circuit or service cabinet, by maintenance as part of the project. On projects where there is additional electrical work, de-energized sign lights shall be removed and wiring shall be removed back to the point where the sign lighting circuit connects to any part of the lighting circuit to remain, or to the service cabinet, as appropriate. Replace any splices where a circuit branch is removed from the splice point.

Overhead sign lights shall not be used. Where overhead sign visibility is less than 800 feet due to intervening sight obstructions such as highway structures or roadside features, roadside illumination may be considered to supplement reduced retroreflectivity from headlights. Overhead signs located within an area of continuous highway illumination are considered sufficiently illuminated.

Exhibit 1020-1 Reflective Sheeting Requirements for Overhead Signs

Overhead Sign Type	Sheeting Type (Background)	Sheeting Type (Legend & Border)
EXIT ONLY guide sign	IV*	XI
Guide signs for left side exits	IV	XI
Other guide signs	IV	XI
Overhead street name signs	IV	XI
Regulatory signs	IV	n/a
Warning signs	IX or XI	n/a

*For Yellow Background Sheeting, use Type IX or XI Fluorescent Sheeting.

1020.03(2) Vertical Clearance

The minimum vertical clearance from the roadway surface to the lowest point of an overhead sign assembly is 17 feet 6 inches. The minimum vertical clearance from the roadway surface to the lowest point of an overhead sign assembly without sign light(s) is 19 feet 6 inches. The maximum clearance is 21 feet. Vertically unbalanced mountings should be avoided on all overhead sign structures. Provide existing and proposed sign dimensions to the Bridge Preservation Office for review when replacing or modifying existing overhead signs. Contact the HQ Traffic Office regarding signs under bridges and in tunnels.

1020.03(3) Horizontal Placement

Consider roadway geometrics and anticipated traffic characteristics when locating signs above the lane(s) to which they apply. Install advance guide signs/exit direction signs that require an EXIT ONLY and “down arrow” panel directly above the drop lanes. To reduce driver confusion about which lane is being dropped, avoid locating a sign with an EXIT ONLY panel on a horizontal curve.

1020.03(4) Service Walkways

Walkways are provided on structure-mounted signs, truss-type sign bridges, and truss-type cantilever sign supports where roadway and traffic conditions prohibit normal sign maintenance activities. Monotube sign bridges/cantilever sign supports normally do not have service walkways.

Vandalism of signs, particularly in the form of graffiti, can be a major problem in some areas. Vandals sometimes use the service walkways and vandalize the signs. Maintenance costs for cleaning or replacing the vandalized signs at these locations can exceed the benefit of providing the service walkway.

1020.04 State Highway Route Numbers

For state routes, [RCW 47.36.095](#) authorizes WSDOT to sign state highways using a system of state route numbers assigned to eliminate duplication of numbers. This numbering system follows the system employed by the federal government in the assignment of Interstate and U.S. routes: odd numbers indicate general north-south routes and even numbers indicate general east-west routes.

1020.05 Mileposts

Milepost markers are a part of a statewide system for all state highways and are installed in accordance with [Executive Order E 1064](#), “State Route Mileposts,” and Chapter 2 of the [Traffic Manual](#).

1020.06 Guide Sign Plan

A preliminary guide sign plan is developed to identify existing and proposed guide signing on state highways and is reviewed by the region Traffic Engineer. Preliminary guide signs for Interstate routes are to be furnished to the HQ Traffic Office for review and concurrence.

The plan provides an easily understood graphic representation of the signing and its continuity to motorist destinations, activities, and services. It is also used to identify deficiencies or poorly defined routes of travel. A guide sign plan for safety and mobility Improvement projects is desirable. When proposed highway work affects signing to a city or town, the guide sign plan can be furnished to the official governing body for review and consideration. The guide sign plan is reviewed and approved by the region Traffic Engineer.

1020.07 Documentation

Refer to Chapter 300 for design documentation requirements.

1020.08 References

1020.08(1) Federal/State Laws and Codes

[23 Code of Federal Regulations \(CFR\) 655](#), Traffic Operations
WSDOT [Executive Order E 1064](#), "State Route Mileposts," WSDOT
[Revised Code of Washington \(RCW\) 47.36](#), Traffic control devices

1020.08(2) Design Guidance

[Manual on Uniform Traffic Control Devices for Streets and Highways \(MUTCD\)](#), 2009 Edition, FHWA, 2003, including the Washington State Modifications to the MUTCD, [WAC 468-95Plans Preparation Manual](#), M 22-31, WSDOT
[Sign Fabrication Manual](#), M 55-05, WSDOT
[Standard Plans for Road, Bridge, and Municipal Construction \(Standard Plans\)](#), M 21-01, WSDOT
[Standard Specifications for Road, Bridge, and Municipal Construction \(Standard Specifications\)](#), M 41-10, WSDOT
[Standard Specifications for Structural Supports for Highway Signs, Luminaires, and Traffic Signals](#), Edition, Washington DC, AASHTO, 2001
[Traffic Manual](#), M 51-02, WSDOT

Exhibit 1020-2 Timber Posts

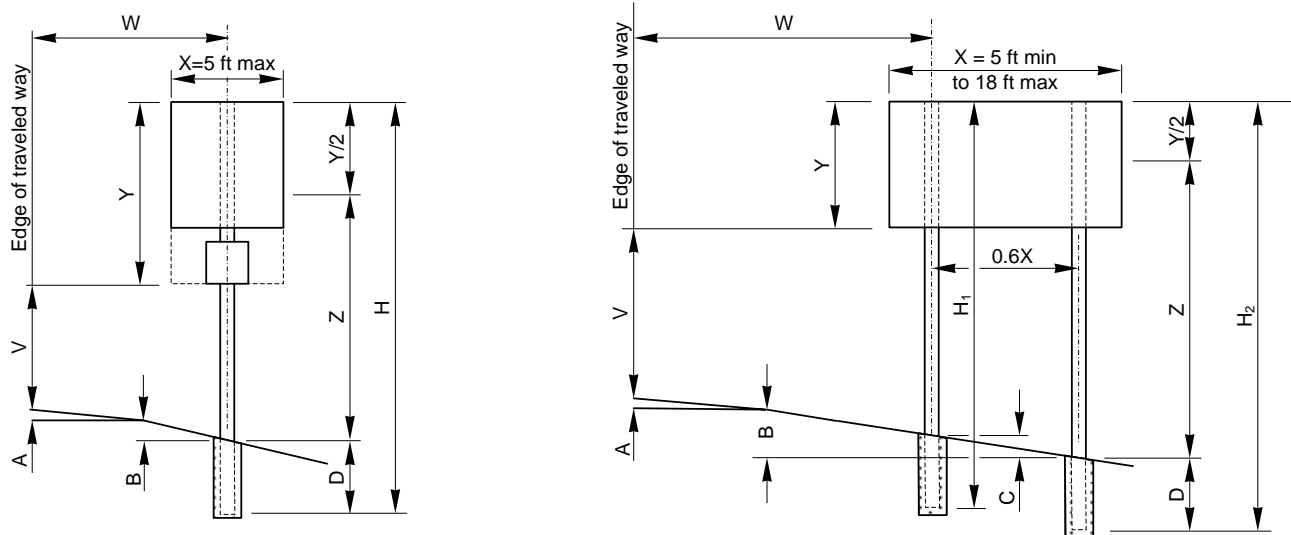

Notes:

The following designs are not permitted when a sign is to be located in or outside the Design Clear Zone in an area where it is likely to be struck by an errant vehicle:

1. A sign with any post larger than 6x8 inches.
2. A 2-post, 3-post, or 4-post sign that uses 6x6-inch or larger posts and has two posts spaced less than 7 ft apart on center.

Post Size (in)	(X)(Y)(Z) (ft ³)				D (ft)
	Number of Posts				
	1	2	3	4	
4 x 4	60	115	175	235	3
4 x 6	125	335	500	675	4
6 x 6	200	415	620	815	4
6 x 8	330	695	1150	1515	5
6 x 10	670	1355	2030	2700	6
8 x 10	835	1685	2515	3360	6
6 x 12	985	2005	2965	3945	7

- Values shown are the maximum permitted.
- For timber grade requirements, see the Standard Specifications.
- Foundation depths are based on allowable lateral bearing pressure in excess of 2500 psf.
- If the value (X)(Y)(Z) amount exceeds the limit for 6x12 post(s), use steel post(s) for sign installation.

A = Vertical distance from edge of traveled way to edge of shoulder

B = Vertical distance from slope catch point to centerline of longest post

C = Vertical distance between adjacent posts

X & Y = Single sign or back-to-back signs: Overall dimensions of the sign

Multiple signs: Dimensions of the area within the perimeter of a rectangle enclosing the extremities of the sign

Z = Height from ground line to midheight of sign at the centerline of the longest post

D = Embedment depth

H = Total post height

V = Vertical clearance from edge of traveled way

W = Distance from edge of traveled way to the centerline of the post nearest the roadway

Design Example – Single Post

Given:

- Sign 3 ft wide, 3.5 ft high; a secondary sign 1.5 ft wide, 2 ft high, mounted 3 inches (0.25 ft) below;
- 8-ft shoulder with 2% slope; 6H:1V embankment;
- W = 15 ft; V = 5 ft

Solution:

- X = 3 ft
- Y = 3.5 + 2 + 0.25 = 5.75 ft
- A = (0.02)(8) = 0.16
- B = (W-8)/6 = (15-8)/6 = 1.17
- Z = Y/2 + V + A + B
- = (5.75/2) + 5 + 0.16 + 1.17 = 9.2 ft
- (X)(Y)(Z) = (3)(5.75)(9.2) = 158.7 ft³
- Since 159 ft³ < 200 ft³, from Table 1, select 6x6 post
- H = 9.2 + (5.75/2) + 4 = 16.1 ft

Design Example – Double Post

Given:

- Sign 12 ft wide, 4 ft high; 10-ft shoulder with 2% slope; 6H:1V embankment; W = 25 ft; V = 7 ft

Solution:

- X = 12 ft; Y = 4 ft
- A = (0.02)(10) = 0.2
- B = [(W-10) + (0.6X)]/6 = [(25-10) + (0.6)(12)]/6 = 3.7
- C = (0.6)(12)/6 = 1.2
- Z = Y/2 + V + A + B
- = 4/2 + 7 + 0.2 + 3.7 = 12.9 ft
- (X)(Y)(Z) = (12)(4)(12.9) = 619 ft³
- Since 619 ft³ < 695 ft³, select two 6x8 posts.
- H₂ = Y/2 + Z + D = 4/2 + 12.9 + 5 = 19.9 ft
- H₁ = H₂ - C = 19.9 - 1.2 = 18.7 ft

Note: 6x6 and larger posts require 7-ft spacing. Sign may be installed within the Design Clear Zone.

Exhibit 1020-3 Wide Flange Steel Posts

X & Y = Single sign or back-to-back signs: Overall dimensions of the sign

Multiple signs: Dimensions of the area within the perimeter of a rectangle enclosing the extremities of the signs

Z = Height from the base connection (2½ inches above the post foundation for wide flange beams) to the midheight of the sign at the centerline of the longest post

H = Post length

V = Vertical clearance from the edge of traveled way

W = Distance from the edge of traveled way to the centerline of the longest post nearest the roadway

Design Example – Steel Post Selection

Given:

- Sign 22 ft wide, 12 ft high; 10 ft shoulder with 2% slope; 3H:1V embankment; W = 32 ft; V = 7ft.

Solution:

- X = 22
- Y = 12
- A = (0.02)(10) = 0.2
- B = [(W-10) + (0.7)(X/3)] = [(32-10) + (0.7x22)]/3 = 12.5
- C = (0.35)(22)/3 = 2.6
- Z = Y/2 + V + A + B - 0.21
- = 12/2 + 7 + 0.2 + 12.5 - 0.21 = 25.5 ft
- (X)(Y)(Z) = (22)(12)(25.5) = 6729 ft³

Since 6729 ft³ < 9480 ft³, select three W10x26 (ASTM A36) or W10x22 (ASTM A992) (see the [Standard Plans](#))

- H₃ = 12/2 + 25.5 = 31.5 ft
- H₂ = H₃ - C = 31.5 - 2.6 = 28.9 ft
- H₁ = H₂ - C = 28.9 - 2.6 = 26.3 ft

Table 1 Wide Flange Steel Post Selection

Wide Flange Beam			
Post Size		(X)(Y)(Z) (ft ³)	
		Number of Posts	
ASTM A992	ASTM A36	2	3
W6x9	W6x12	1570	2355
W6x12	W6x16	2340	3510
W8x18	W8x21	4120	6180
W10x22	W10x26	6320	9480
W12x26	W12x30	8700	---

Table 2 Wide Flange Beam Weights

Beam Size	Weight lbs/ft	Beam Size	Weight lbs/ft
W6x9	9	W8x21	21
W6x12	12	W10x22	22
W6x16	16	W10x26	26
W8x18	18	W12x26	26
		W10x30	30

Notes:

Values shown in Table 1 are the maximum permitted.

A single-wide flange post installation is not allowed.

Consider using one of the following: perforated square steel tube posts, solid steel tube posts, or round steel posts.

For post selection for other than wide flange beam supports and a single-post assembly, see the [Standard Plans](#).

(See the [Standard Plans](#) for additional information.)

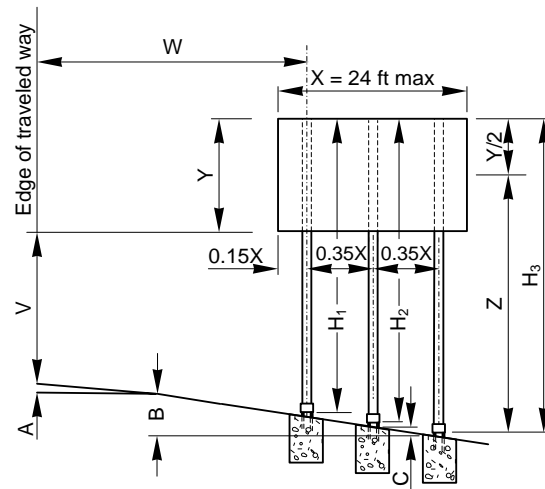
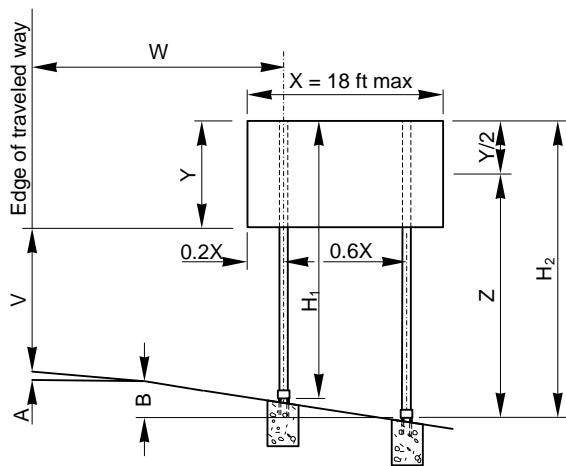

Exhibit 1020-4 Square Steel Posts

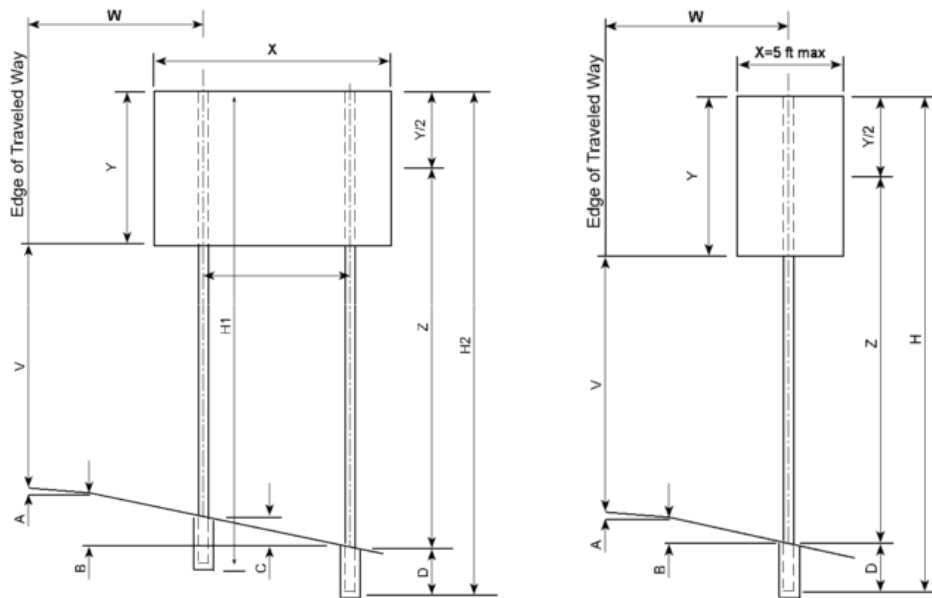

Table 1 – 2 1/2" & 3" Square Steel Posts

Posts	Maximum XYZ		
	1 Post	*2 Post	*3 Post
2 1/2" PSST 12 Gage	172	344	516
*2 1/2" PSST with 2 1/4" PSST (7') insert 12 Gage	309	618	927
*3" Solid 7 Gage	471	942	1413

* Slip base required (maximum 3 slip bases allowed in 7' span)

Foundation depths are based on allowable lateral bearing pressure in excess of 2500 psf.

If the value (X)(Y)(Z) amount exceeds the limit for 3 – 3-inch post(s), use wide flange steel post(s) for sign installation.

- A = Vertical distance from edge of traveled way to edge of shoulder
- B = Vertical distance from slope catch point to centerline of longest post
- C = Vertical distance between adjacent posts
- X & Y = Single sign or back-to-back signs: Overall dimensions of the sign

Multiple signs: Dimensions of the area within the perimeter of a rectangle enclosing the extremities of the sign.

Design Example – Single Post

Given:

Sign 4 ft wide, 5 ft high; 8-ft shoulder with 2% slope; 6H:1V embankment; W = 15 ft; V = 5 ft

Solution:

$$\begin{aligned}
 X &= 4 \text{ ft} \\
 Y &= 5 + 2 + 0.25 = 7.75 \text{ ft} \\
 A &= (0.02)(8) = 0.16 \\
 B &= (W-8)/6 = (15-8)/6 = 1.17 \\
 Z &= Y/2 + V + A + B \\
 &= (5/2) + 5 + 0.16 + 1.17 = 8.8 \text{ ft} \\
 (X)(Y)(Z) &= (4)(5)(8.8) = 176 \text{ ft}^3 \\
 \text{Since } 176 \text{ ft}^3 &< 309 \text{ ft}^3, \text{ from Table 1, select 2 1/2" post with 2 1/4" post insert} \\
 H &= 8.8 + (5/2) + 3 = 16.1 \text{ ft}
 \end{aligned}$$

