

Chapter 11 Communication of FBs-PLC

The FBs-PLC main unit has been built in the communication port0 with optional USB or RS232 interface. If additional communication boards (CB) have been purchased, then it can increase to 2~3 communication interfaces (depending on the model of CB). If it is still not enough, communication modules can be added to expand the number of communication interfaces to 5 (PORT0~PORT4). There are three types of communication interfaces, RS232、RS485 or Ethernet, to choose from in both CB and CM. Among them, Port 0 is a permanent interface for FATEK communications interface, which is controlled by the CPU of the PLC, using FATEK "Standard communication driver" to manage the communication transactions of the Port, i.e. "FATEK communication protocol". Any access to the Port must comply with the format of "FATEK communication protocol" to get responses from the PLC. This includes starting character, station no., command code, body, error check code, ending characters, etc.; for more details please refer to "Appendix 2: FATEK communication protocol". WinProladder and numerous HMI and SCADA softwares are equipped with communication drivers complying with this communication protocol, therefore where the parameters on hardware interface and communications are consistent, communication connection can be established by just connecting the communication Port with the "Standard Interface". If the communication driver with complying communication protocol is not available, besides writing its own commands complying with "FATEK communication protocol" to communicate with PLC, the commonly used industrial ModBus RTU protocol can also be used to establish a connection with FBs-PLC. The factory setting and the PLC system initialization on Port 1 ~ Port 4 default to FATEK standard communication interface; though in order to meet the extensive application and requirements of communication connection, Port 1 ~ Port 4 provides FATEK standard communication interface, as well as providing easy communication commands that support powerful functions to allow users to compile their required communication application software through the Ladder diagram program, and easily achieve the aim of system integration and distributed monitoring. Further detail will be explained in subsequent chapters.

11.1 Functions and applications of FBs-PLC communication ports

Besides the hardware interface distinction of USB, RS232, RS485 or Ethernet among the 5 COM ports of FBs-PLC, there are also 3 software interface types in terms of software interfaces. The table below shows the software interface types that can be configured on the 5 COM ports of FBs-PLC:

Available types	Communication Port					Notes
	Port0	Port1	Port2	Port4	Port5	
Software Interface						
Standard Interface	○	○	○	○	○	Port controlled by CPU, using FATEK "Standard communication driver" or ModBus RTU communication driver, but Port0 does not support ModBus RTU communication protocol.
Dedicated Modem interface		○				Port controlled by CPU, using the Modem driver + FATEK "Standard communication driver" or ModBus RTU communication driver.
Ladder diagram program controlled interface		○	○	○	○	Port controlled by users (Ladder diagram program)
Interface type configuration method	—	Register configure	PLC Auto configure	PLC Auto configure	PLC Auto configure	

- Standard Interface : Port0 ~ Port4 can all be configured into this type of interface (Port0 can only be this type of interface and only provides FATEK standard communication driver). Under this interface type, the Port is controlled by the standard communication driver of FBs-PLC (using FATEK communication protocol or ModBus RTU communication protocol), hence called "standard interface". To communication with the "Standard Interface", the connection can only be established by complying with FATEK FB-PLC communication protocol or ModBus RTU communication protocol.

※ Port0 doesn't support ModBus RTU communication protocol.

- Dedicated Modem Interface : Only Port1 can select this interface type. Under this interface type, Port1 is controlled by the built-in “MODEM driver” of FBs-PLC, in charge of telephone reception or dialing tasks, and then hand the connection over to FATEK standard communication driver after the connection is established, subsequent operation is the same as the “Standard interface” above.
- Ladder diagram Program controlled interface : Port1 ~ Port4 can all select this interface type. Under this interface type, the Port will be controlled by the user’s Ladder diagram program instructions, such as FUN94, FUN150, FUN151, etc., hence users can gain control of the Port through the Ladder program.

The following sections will detail the functions and applications of the 5 Ports on FBs-PLC under each of the 3 different software interfaces.

* Port0 ~ Port4 communication parameter are default to :

Baud Rate: 9600 bps
 Data Length: 7 Bits
 Parity: Even
 Stop Bit: 1 Bit

11.1.1 Communication port 0 : USB or RS232 interface

Functional specification

- USB interface complies with standard functional specification of USB1.1
- RS232 interface functional specification complies with the EIA RS232 standard, with 5 types of communication speeds 9600, 19200, 38400, 57600 and 115200 configurable.

Basic usage

- Besides providing the standard RS232 interface, models with USB interface are also provided since more and more notebook computers are using USB port to replace COM ports due to light weight and thickness considerations.
- The main purpose of Port0 is to provide a communication interface for program editing, so generally speaking it would be in passive receiving mode.

Extended usage

- ① Besides program editing, it can also connect to HMI, SCADA equipped with FATEK communication driver.
- ② Through conversion of interface signal into RS485 signal, connections can be made with RS485 interface peripherals, such as computers, WinProladder, HMI, SCADA, etc. or become a Slave of the FATEK CPU Link network.

11.1.2 Communication port1 ~ port4 : RS232 or RS485 interface

Functional specification

- RS232 interface functional specification complies with the EIA RS232C standard, communication parameters are adjustable up to highest communication rate of 921.6Kbps. Factory setting and system initialization communication parameter is configured to the default communication parameter.
- RS485 interface functional specification complies with EIA RS485 standard.

Basic usage

There are 3 types of software interface are selectable as follows :

① Standard interface :

Connectable to peripherals with RS232 or RS485 interface, such as computer, WinProladder, HMI, SCADA, etc.

② Port1 dedicated modem interface :

It can actively or passively connect to remote computers or conduct auto information gathering, warning, anomaly reporting or dial B.B. call for remote servicing via MODEM.

③ Ladder diagram Program controlled interface :

User can control Port1~Port4 through the ladder diagram instructions, such as FUN94 (ASCWR) command to take control of Port1 and connect to printers with RS232 hardware interface for Chinese/English report printing; FUN151 (CLINK) command takes control of Port1~Port4 to establish connection with FATEK CPU Link or peripherals with RS232 or RS485 interfaces; FUN150 (MBUS) command can turn Port1~Port4 into a master of ModBus RTU communication protocol for connecting Slaves with this communication protocol.

④ Port2 can provide FATEK high speed CPU Link function.

Extended usage

- Under Standard interface, act as the Slave for multi-drop FATEK RS485 or point to point RS232 CPU LINK network.
- Under Ladder diagram program controlled interface types, Port1~Port4 has the following functions:
 - ① Use MD0 mode of FUN151 (CLINK) instruction to act as the master for FATEK CPU Link network.
 - ② Use MD1 mode of FUN151 (CLINK) instruction to actively connect to intelligent peripherals equipped with this communication interface, such as other brands' PLC, servo driver, temperature controller, inverter, message display, etc.
 - ③ Use MD2 mode of FUN151 (CLINK) instruction for connection to receive the intelligent peripherals equipped with this communication interface, such as card readers, bar code readers, weighing scales, etc.
 - ④ Port2 can utilize MD3 mode of FUN151 (CLINK) instruction to act as the master for FATEK high speed CPU Link network.
 - ⑤ Use FUN150 (Mbus) instruction to act as the Master for ModBus RTU communication protocol to connect to peripherals with this communication protocol.

11.1.3 Ethernet interface

Functional specification

- Comply with IEEE802.3 standard to provide 10Base T interface.

Basic usage

- Provide intranet or internet connectivity within the plant. It can connect to WinProladder, HMI, SCADA with Ethernet network interface and FATEK communications driver or ModBus driver.

Extended usage

- It can coordinate with MD0 mode of FUN151(CLINK) instruction to provide remote data acquisition through the Ethernet network between the PLC's. (* Client Mode).

Note : For details on Client Mode of FBs-PLC network interface, please refer to the explanations in section 11.8.5.2.

11.2 How to use FBs-PLC communication functions

Refer to the diagram in Section 2.2 “Combination of PLC and Peripheral Systems” in the “Hardware Manual” for the connection of FBs-PLC to the host computer, intelligent peripherals, and other PLCs.

Among Port0~Port4, only Port 2 provides real-time response function (real-time: data is processed immediately when received or sent without being affected by scan time.) and communicates with binary code (two times ASCII code). Other ports use ASCII code for communication in the standard mode and data will not be processed until the scan is complete and housekeeping is active. Thus, there will have the service delay because of the scan time. Port2 should be provided for each PLC to share data with each other via “FATEK high-speed CPU Link” (i.e., the MD3 mode of FUN151 (CLINK)) to meet the real time monitor requirements. Port0, Port1, Port3, Port4 should be used for intelligent peripherals, HMI, SCADA, and other non-real-time control applications for data collection and monitoring.

11.3 Hardware wiring notifications for RS485 interface

In the FBs-PLC communication interfaces, RS232 provides only point to point connection function while RS485 provides connection for multiple stations. Its wiring distance should conform to the restriction specified in the EIA standard.

The principle that connection distance should be as short as possible and the station should be far away from high noise sources must be observed for hardware wiring. RS232 is for point to point connection with a shorter connection distance and the standard cable sold in the market or provided by FATEK is applicable. However, for high-speed RS485 network, communication quality is affected and operation might be seriously interfered with if the problems, such as high baud rate, long connection distance, high signal attenuation, multiple stations, bad grounding, high noise, terminating impedance mapping, and topology, are not solved appropriately. Please read the notes of hardware wiring for RS485 network at the end of this section carefully.

Limits on the number of stations

Though the number of FBs-PLC stations can be set up to 254, 16 stations are the maximum for hardware driving for RS485 interface. If more than 16 stations are required, a RS485 amplifier (FBs-CM5R) must be used. 16 additional stations can be assigned to one amplifier up to the max. 254 stations.

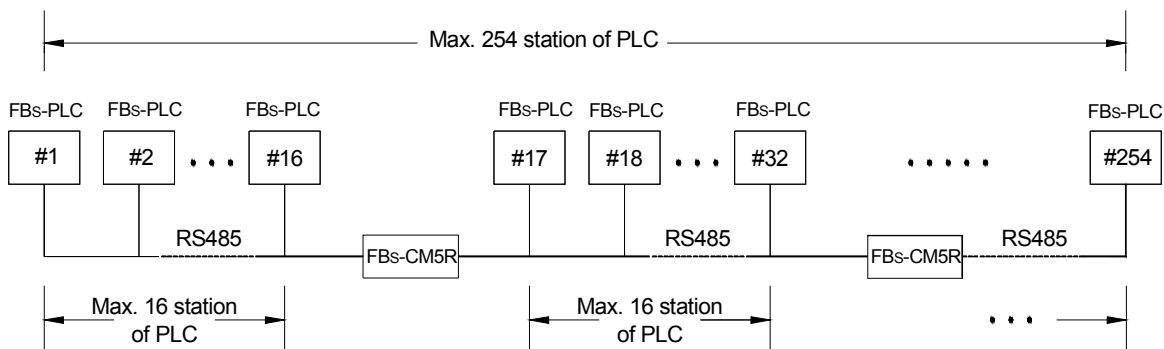

Limit on distance

The following diagram shows the relationship between the baud rate and transmission distance of RS485 standard interface.

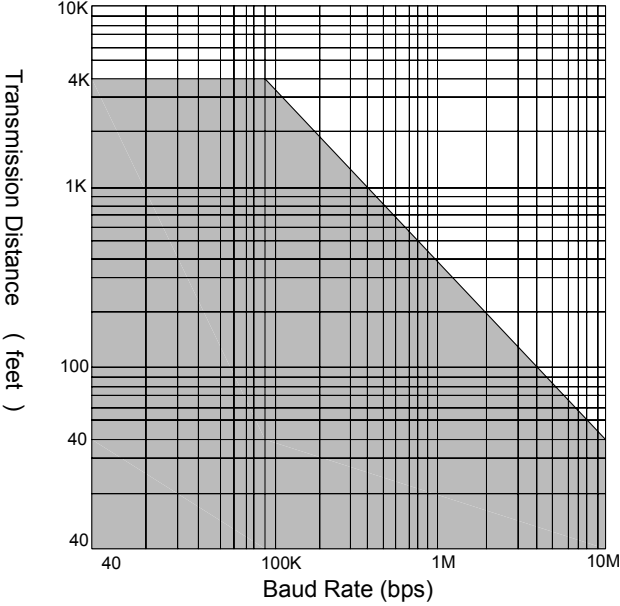

Cable

Use the shielded twisted pair cables for connection. Cable quality is an important factor to transmission signal. When the baud rate is high, low quality twisted pair (e.g., PVC twisted pair cables) will cause extremely high signal attenuation and considerably shorten the transmission distance. Its noise immunity is poorer. In a circumstance where the baud rate and noise is high, and the distance is long, use high quality twisted pair cables (such as Belden 9841 polyethylene twisted pair cables), Its dielectric loss can be 1000 times lesser than that of PVC twisted pair cable. But in a circumstance where the baud rate and noise are low, PVC twisted pair cable is an acceptable and economical alternative. If the transmission distance is too long to raise signal attenuation, use a RS485 amplifier (FBs-CM5R) to amplify signal.

Topology

Topology is a graph structure of transmission connection. The topology of RS485 must be in a Bus structure. All cables must be connected from the first station to the second station, from the second station to the third station, to the last station. As shown in the following diagrams, both star and ring connections are not allowed. If FBs-CM5H is used, RS485 can be set to star connection, but ring connection is still not allowed.

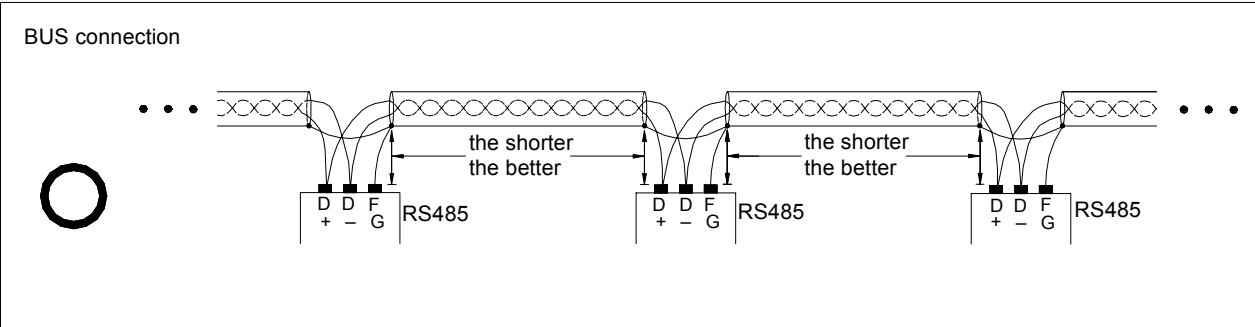

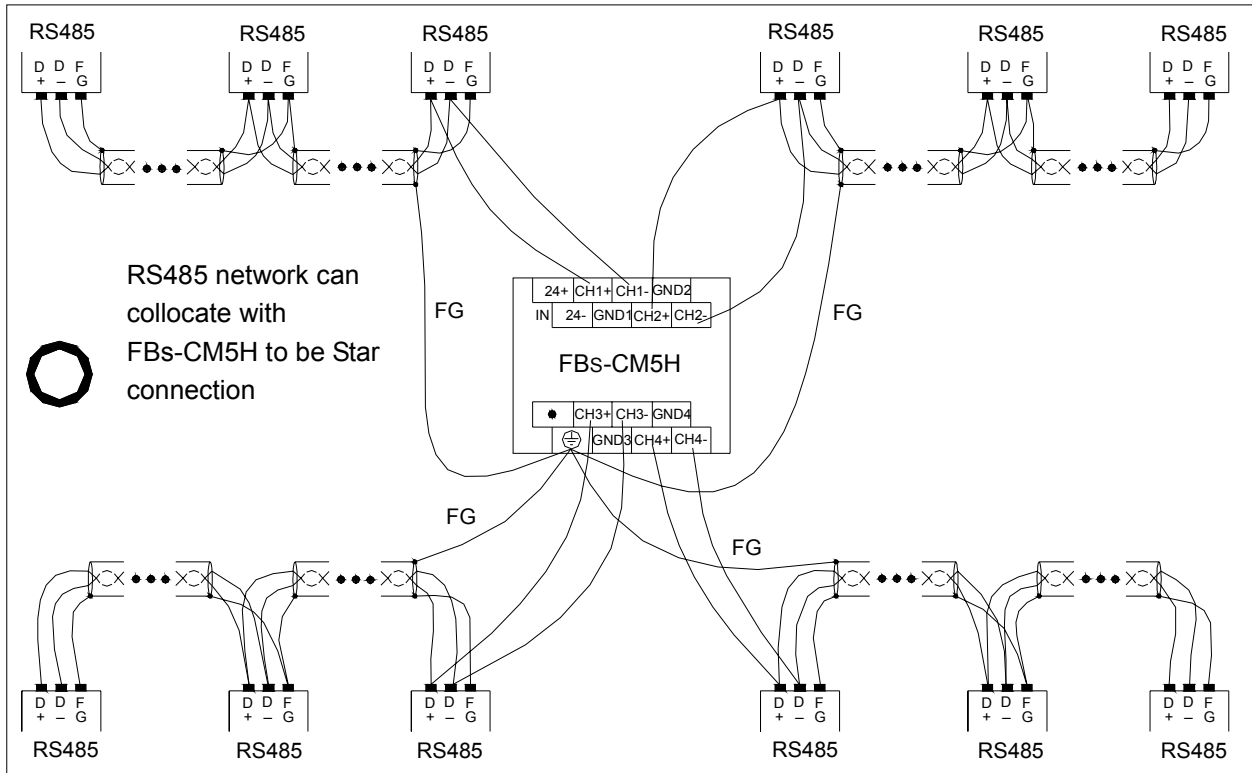
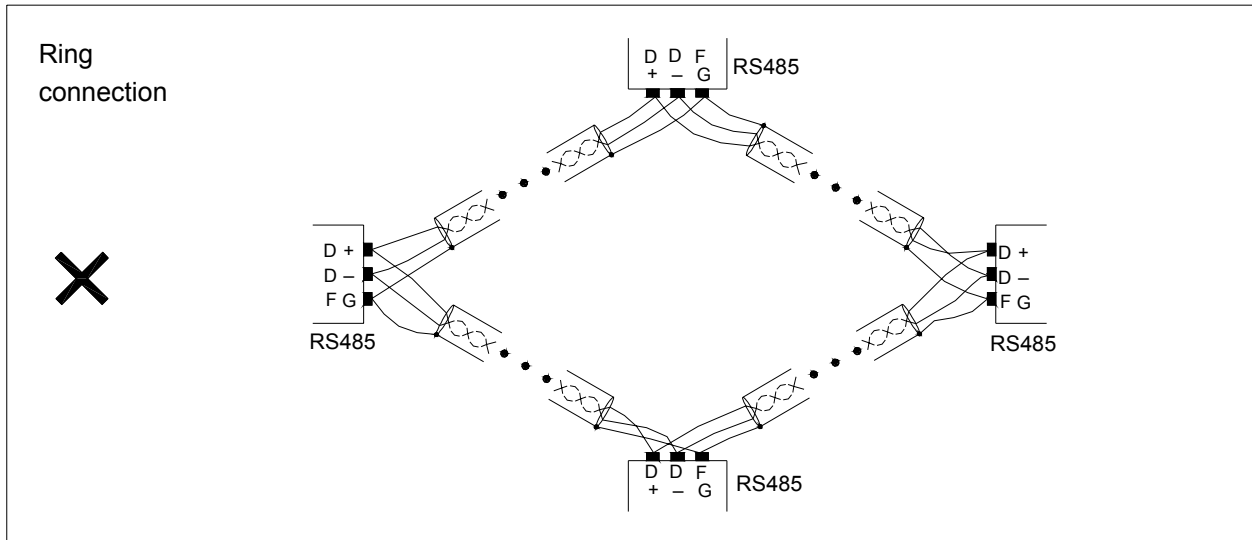
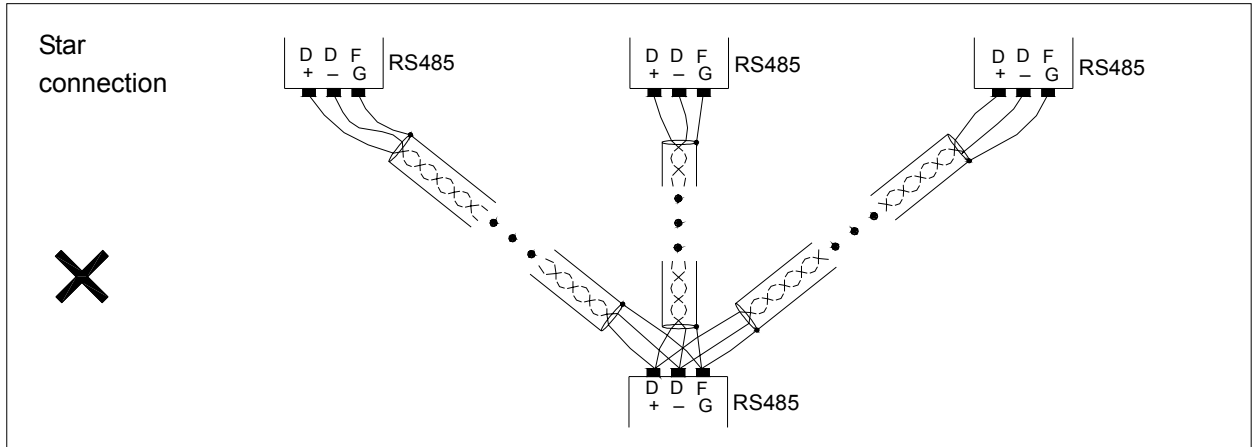

FG grounding

Though RS485 network can be connected with two cables, the connection is easily affected by noise. To improve communication quality, the ground potential difference (common mode voltage) between two stations should not exceed the max. allowable common mode voltage of the RS485 transmission IC. 7V shall not be exceeded when FBs-PLC IC is used; otherwise, RS485 may not operate normally.

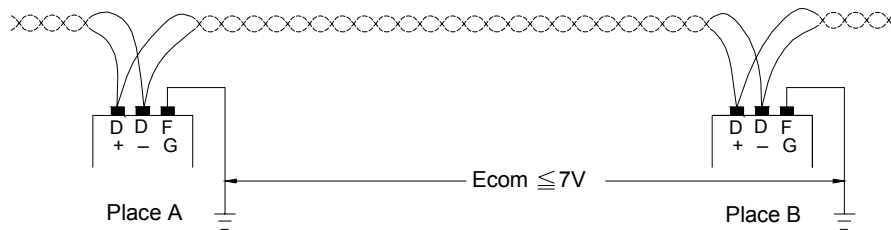

No matter how the ground potential is, we recommend using a twisted pair cable covered with shielding. The FG of each station is connected with the ground wire covered with shielding (similar to the above-mentioned "topology") to clear common mode voltage and provides the shortest circuit for signal transmission to improve the anti-noise capacity.

Terminating impedance

Different transmission cables have different characteristic impedance (the characteristic impedance of a twisted pair cable is approximately 120Ω). When the signal is transmitted to the terminating resistor of a cable, reflection and waveform distortion (either sinking or protruding) will be caused if the terminating impedance is different from its characteristic impedance. This distortion is not obvious when the cable is short but it will be more serious with longer cables. Finally, PLCs cannot transmit correctly and a terminating resistor should be installed to solve this problem. A 120Ω terminating resistor has been installed inside the FBs-PLC. When a terminating resistor is required to be added, open the cover and toggle the DIP switch to the "ON" position (DIP switch is set to "OFF" position by the factory). Terminating resistors can only be added to each PLC on the utmost left and right ends of the Bus. All the DIP switches between both end should be on the position "OFF", or the driving power of RS485 may become insufficient. The diagram below shows the setting and application of terminating resistors:

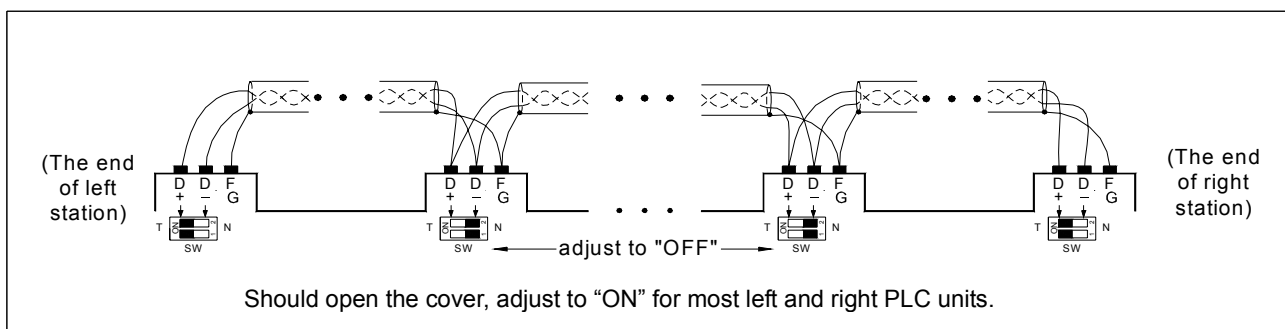

Strategies against noise

When wiring for RS485 network is implemented based on the described materials and rules or a 120Ω terminating resistor is added, most noise situations are eliminated. However, if noise cannot be eliminated, it means that there are strong noise sources near the RS485 network. Besides keeping cables far away from noise sources (e.g., electromagnetic valves, inverters, servo drivers, or other power units), the most effective way to solve the problem is to use noise suppression components. Refer to the description in Section 7.5 in the “Hardware Manual” for noise suppression of electromagnetic valves, relays and other devices with inductive load. The diagram below shows the noise suppression approaches for inverters, servo drivers, and other high-noise power units (i.e., add X capacitance or Y capacitance or X+Y capacitance).

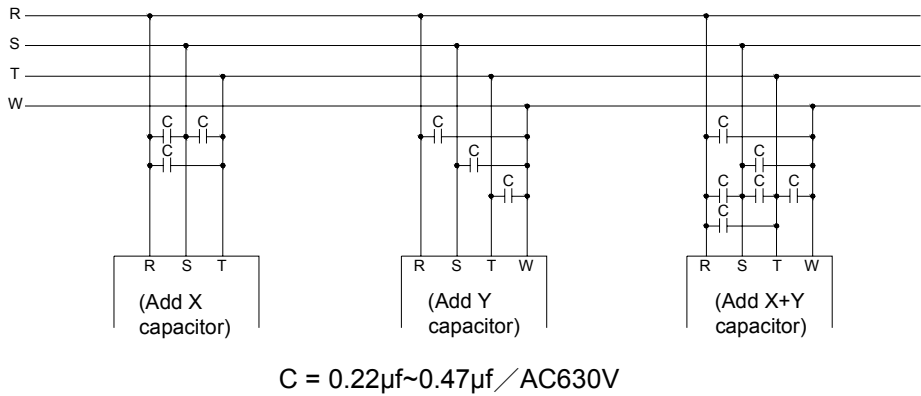

⚠ Caution

- Hardware wiring for communication network and addition and removal of communication stations should be implemented with PLC disconnected. Don't work especially when PLC is running, or communication errors may occur to generate incorrect PLC output.

11.4 How to use FBs-PLC communication ports

The requirements for communication are that (1) hardware interfaces and mechanisms, (2) communication parameters and (3) software interfaces (i.e. the protocol) of the receiver/ sender must be consistent. The same are applicable to PLC. After the above three fundamentals are meet, PLC will communicate with other PLCs or peripherals. The following will describe these three fundamentals.

11.4.1 Matching of hardware interfaces and mechanisms

In order to meet the interface requirement of variety peripherals, the FBs-PLC provides USB, RS232, RS485 and Ethernet communication interfaces for choice. When install, care should be taken if the hardware interface is of the same type. Incorrect connection of different type of communication interface may cause the permanent hardware failure. Also please make sure that the signals of mating connector are all match. For example, TXD must connect to RXD, RTS (if any) should be connected to CTS. The interface of USB, RS232 and RS485 are described at bellow (Ethernet is described at section 1.8).

Port0 USB interface (built in)

The FBs-PLC equipped with port0 USB interface can be order by suffixed an U letter in the CPU model number. The port0 can only be acted as slave. Its connector is a standard USB B type connector. The user can use the standard USB A to USB B cable (can buy from FATEK, the product number is FBs-USBP0-180, please refer the description at below) to connect the PC and PLC.

Port0 RS232 interface (built in)

The CPU model number with no U letter suffixed is a FBs-PLC that built in a port0 RS232 interface. The connector for port0 RS232 is a 4 pin Mini-DIN female connector. FATEK provides a dedicated connection cable that has a 9 Pin D-sub female connector at one end for the PC or peripherals to connect PLC port0 RS232. The wiring diagrams of port0 USB and RS232 connection cable are shown at below.

FBs-232P0-9F-150 (Mini-DIN male → 9 Pin D-sub female) :

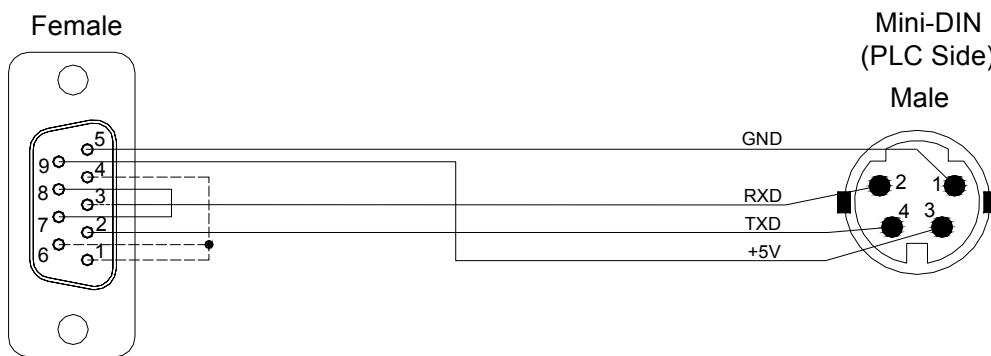

FBs-232P0-9M-400 (Mini-DIN male → 9 Pin D-sub male) :

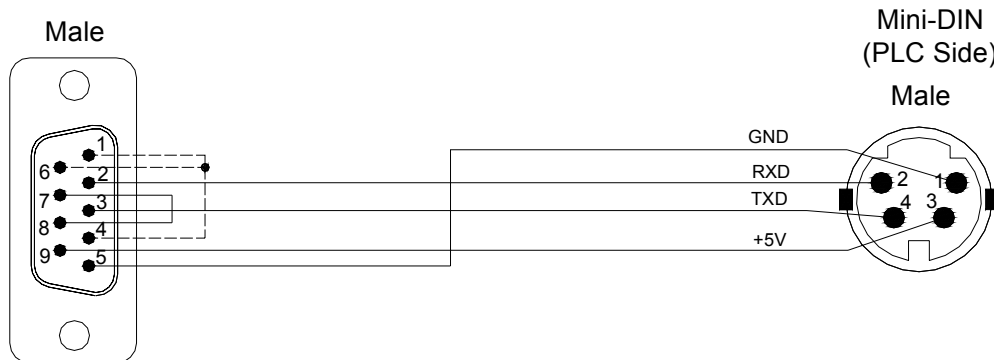

Model	Description
FBs-232P0-9F-150	Dedicated for FBs RS232 Port 0 to 9Pin D-sub female, 150cm long.
FBs-232P0-9M-400	Dedicated for FBs RS232 Port0 to 9Pin D-sub male, 400cm long.
FBs-USBP0-180	Port0 USB cable (standard commercial USB A ↔ B), 180cm long.

FBs - 232 P0 - 9 F - 150

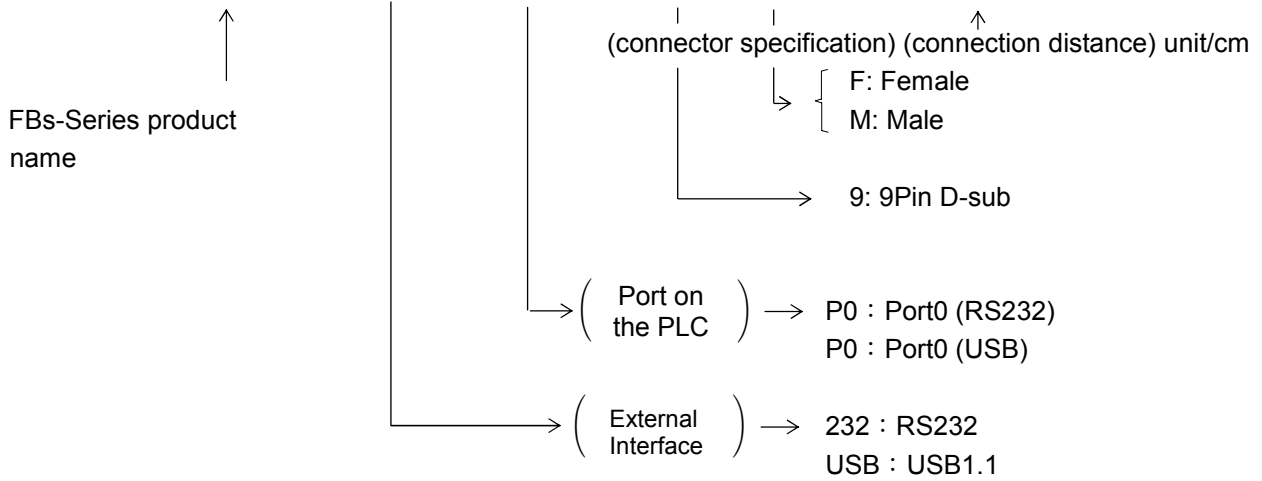

Port1~Port4 RS232 interface (expandable)

The communication port of Port1~Port4 can be utilized by installed the RS232 communication board (or module). Each communication board (or module) provides one or two standard RS232 9 Pin D-sub female connector(s). While application, the user can buy a standard 9 pin RS232 cable directly from computer store or follow the example diagram at below to DIY the cable.

Signal Name		TXD	RXD	RTS	CTS	SG	DTR	DSR
		Pin						
Connector Type		TXD	RXD	RTS	CTS	SG	DTR	DSR
9Pin D-sub	MALE	3	2	7	8	5	4	6
	FEMALE	2	3	8	7	5	6	4

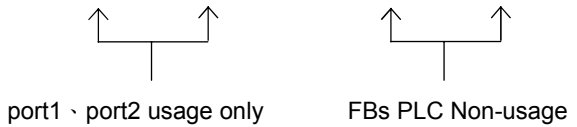

9P D-sub female → 9P D-sub male RS232 communication cable :

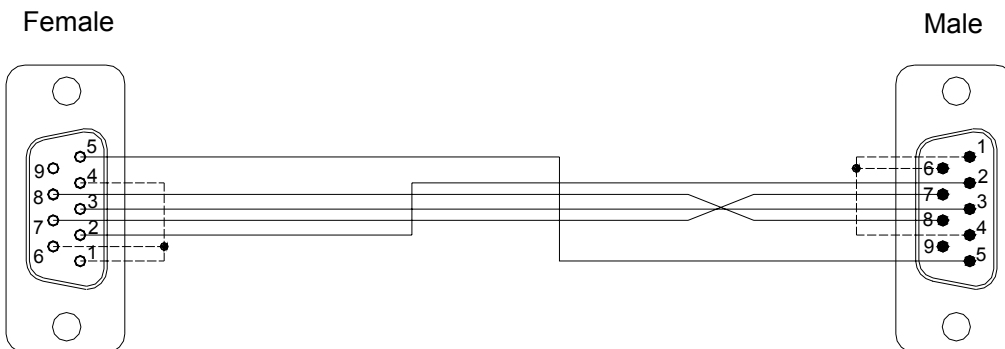

9P D-sub male → 9P D-sub male RS232 communication cable :

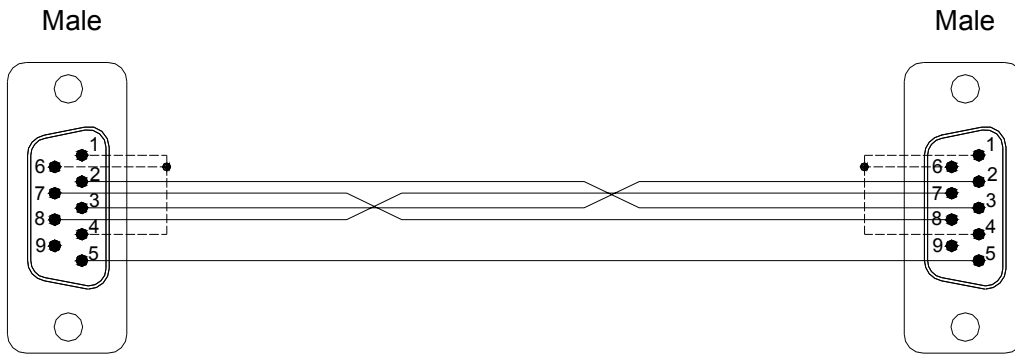

If you make RS232 cables by yourself and the definition of each pin is not clear, use a multimeter for measurement to determine TXD and RXD.

9 Pin connector: The pin 5 is SG;

Measure the pin 2 (red probe) and the pin 5 (black probe) with a multimeter. If it is approximately $-9V$, it means that the pin 2 is the transmission pin; If it is approximately $0V$, it means that the pin 2 is the receiving pin.

Measure the pin 3 (red probe) and the pin 5 (black probe) by a multimeter. If it is approximately $-9V$, it means that the pin 3 is the transmission pin; If it is approximately $0V$, it means that the pin 3 is the receiveing pin.

Port1~Port4 RS485 interface (expandable)

The communication port of Port1~Port4 can be utilized by installed the RS485 communication board (or module). Each communication board (or module) provides one or two standard RS485 3-pin European plug-able terminal block. The pin assignment of connector(s) is show below.

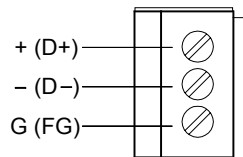

11.4.2 Selection and setting of communication protocols

Besides offering the FATEK protocol by default, Port1~Port4 can be set to ModBus (Slave) protocol. The following shows the setting steps in the WinProladder :

Click the protocol:

→ a port can be set to ModBus RTU or FATEK Protocol:

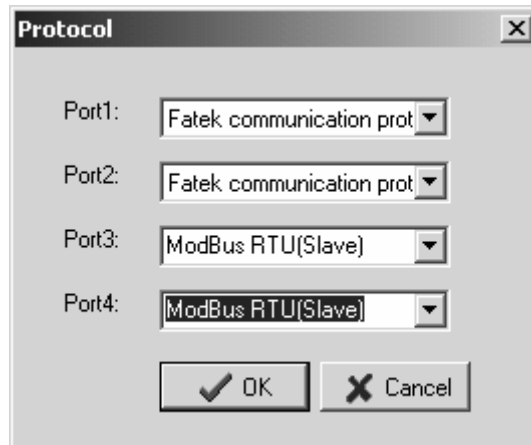

Besides, you also can setting the communication protocol through special register.

- R4047 : Upper Byte = 55H, configure the communication port for ModBus RTU protocol.
 = Other values, Port1~4 don't support ModBus RTU protocol(The defaults are FATEK protocol)
 Lower Byte : Port assignment for ModBus RTU protocol.

Format as below :

Upper Byte	Lower Byte							
55H	b7	b6	b5	b4	b3	b2	b1	b0

- b0, Reserved ;
- b1=0, Port 1 acts as FATEK protocol.
 =1, Port 1 acts as ModBus RTU protocol.
- b2=0, Port 2 acts as FATEK protocol.
 =1, Port 2 acts as ModBus RTU protocol.
- b3=0, Port 3 acts as FATEK protocol.
 =1, Port 3 acts as ModBus RTU protocol.
- b4=0, Port 4 acts as FATEK protocol.
 =1, Port 4 acts as ModBus RTU protocol.
-
-
-
- b5~b7, Reserved

※ It allows to assign multiple ports for ModBus RTU protocol, where the corresponding bit must be 1.

For example :

- R4047=5502H, Assign Port 1 as ModBus RTU protocol;
- R4047=5504H, Assign Port 2 as ModBus RTU protocol;
- R4047=5506H, Assign both Port 1 and Port 2 as ModBus RTU protocol;

Refer to : The rule for address mapping between ModBus and Fatek(Page12-40).

11.4.3 Settings for communication parameters

Communication parameters can be set up for each of the 5 FBs-PLC ports. When out of factory or communication parameters of Port 0~Port 4 are set to the same parameters of Port 0 before shipment or after system initialization. (See the table below.)

Baud Rate	9600 bps
Data Length	7 Bits
Parity Check	Even
Stop Bit	1 Bit

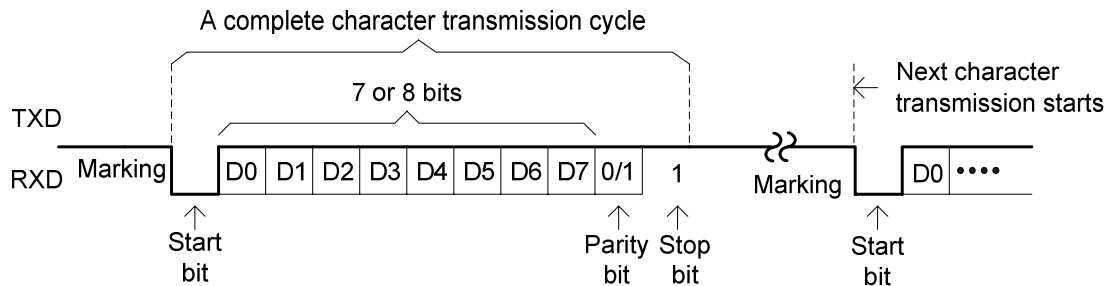

Default communication parameters

Port	Register Setup	Default Value	Default Baud Rate	Other default Parameters
Port 0	R4050	5621H	9600 bps	7-bit Data, Even · 1-bit Stop
Port 1	R4146	5621H	9600 bps	7-bit Data, Even · 1-bit Stop
Port 2	R4158	5621H	9600 bps	7-bit Data, Even · 1-bit Stop
Port 2 (High-speed)	R4161	5665H	153600 bps	8-bit Data, Even · 1-bit Stop
Port 3	R4043	5621H	9600 bps	7-bit Data, Even · 1-bit Stop
Port 4	R4044	5621H	9600 bps	7-bit Data, Even · 1-bit Stop

- ※ When a port is set to ModBus RTU protocol, data bit is always 8-bit.
- ※ Port 1~Port 4 also provides Baud Rate settings for user-defined (1125 bps~1152000 bps).
- ※ Port 0 can be changed the baud rate only the other parameters are always 7-bit Data, Even, 1-bit Stop.
Also, Port 0 supports FATEK communication protocol only.

Setup of port0~port4 communication parameters

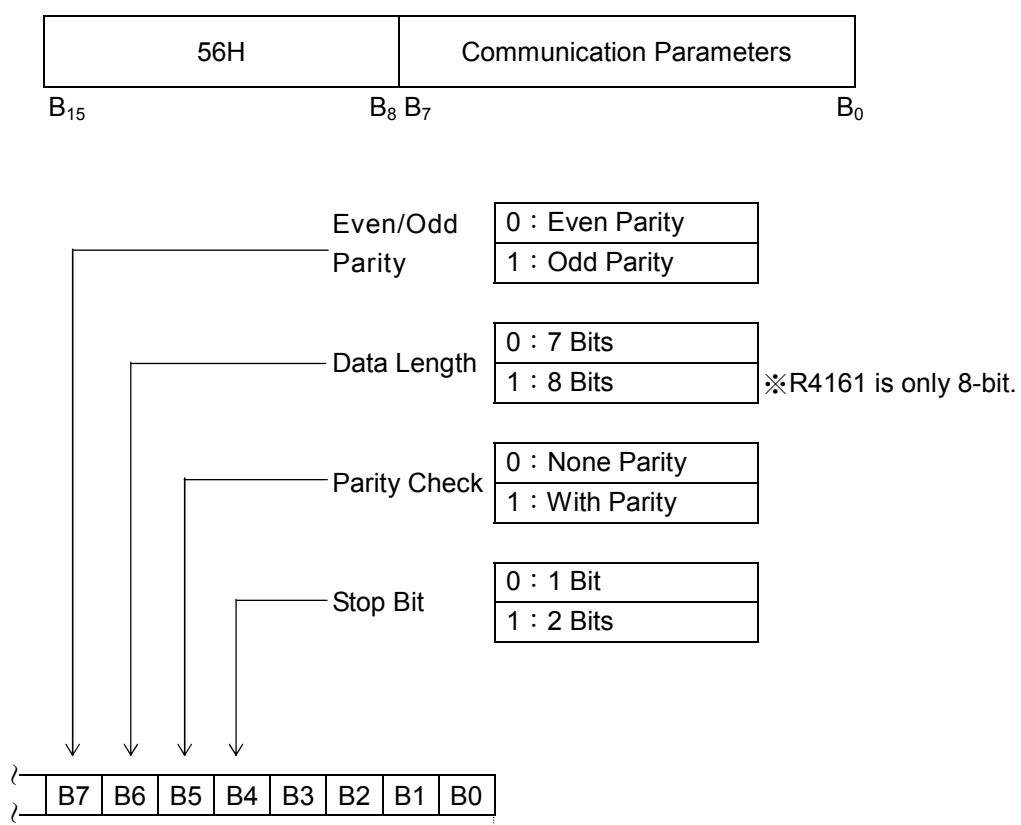

					Value	Baud Rate
0	0	0	0	0		4800 bps
0	0	0	1	1		9600 bps
0	0	1	0	2		19200 bps
0	0	1	1	3		38400 bps
0	1	0	0	4		76800 bps
0	1	0	1	5		153600 bps
0	1	1	0	6		307200 bps
0	1	1	1	7		614400 bps
1	0	0	0	8		7200 bps
1	0	0	1	9		14400 bps
1	0	1	0	A		28800 bps
1	0	1	1	B		57600 bps
1	1	0	0	C		115200 bps
1	1	0	1	D		230400 bps
1	1	1	0	E		921600 bps
1	1	1	1	F		User-defined

※ R4161(PORT2) the high-speed baud rate must be greater than or equal 38400bps.

Port 1~Port 4 provides Baud Rate settings for user-defined (1125 bps~1152000 bps)

Formula

$$\text{Baud_Rate_Div} = \left(\frac{18432000}{\text{Baud_Rate}} \right) - 1 \quad (15 \sim 16383)$$

$$\text{Baud_Rate} = \left(\frac{18432000}{\text{Baud_Rate_Div} + 1} \right) \quad (1125 \text{ bps} \sim 1152000 \text{ bps})$$

Port	Register Setup	Formula
Port 1	D4000	$D4000 = \left(\frac{18432000}{\text{Baud_Rate}} \right) - 1$
Port 2	D4001	$D4001 = \left(\frac{18432000}{\text{Baud_Rate}} \right) - 1$
Port 3	D4002	$D4002 = \left(\frac{18432000}{\text{Baud_Rate}} \right) - 1$
Port 4	D4003	$D4003 = \left(\frac{18432000}{\text{Baud_Rate}} \right) - 1$

Example 1

If you want to set Port 1 Baud Rate to 1200 bps, then R4146 = 56XFH :

$$D4000 = \left(\frac{18432000}{1200} \right) - 1 = 15359$$

Example 2

If you want to set Port 2 Baud Rate to 256000 bps, then R4158 = 56XFH :

$$D4001 = \left(\frac{18432000}{25600} \right) - 1 = 71$$

Without station number checking for HMI or SCADA connecting

While PLC communicating with WinProLadder or Handheld PP, it recognizes the FATEK's internal communication protocol.

While PLC communicating with Man Machine Interface (MMI) or Supervising software (SCADA), it recognizes the FATEK's external communication protocol.

Low byte of R4149 = 1, Port 0 without station number checking while FATEK's external communication protocol.

Low byte of R4155 = 1, Port 1 without station number checking while FATEK's external communication protocol.

High byte of R4155 = 1, Port 2 without station number checking while FATEK's external communication protocol.

Low byte of R4156 = 1, Port 3 without station number checking while FATEK's external communication protocol.

High byte of R4156 = 1, Port 4 without station number checking while FATEK's external communication protocol.

Reply delay time setting

As the PLC received a packet of addressed message and passed the error check, it would reply the message after the reply delay time period.

Low byte of R4040 : Port 0 reply delay time setting (Unit in mS).

High byte of R4040 : Port 1 reply delay time setting (Unit in mS).

Low byte of R4041 : Port 2 reply delay time setting (Unit in mS).

High byte of R4041 : Port 3 reply delay time setting (Unit in mS).

Low byte of R4042 : Port 4 reply delay time setting (Unit in mS).

Transmission delay time setting

While the communication port being used as the master of FATEK CPU LINK (FUN151) or Modbus RTU (FUN150) multidrop's network, it allows the user to set the transmission delay time to slow down the expiration of message frame.

High byte of R4147 : Port 1 transmission delay time setting (Unit in 10mS)

High byte of R4159 : Port 2 transmission delay time setting (Unit in 10mS)

High byte of R4045 : Port 3 transmission delay time setting (Unit in 10mS)

High byte of R4048 : Port 4 transmission delay time setting (Unit in 10mS)

Receive time-out span setting

While the communication port being used as the master of FATEK CPU LINK (FUN151) or Modbus RTU (FUN150) multidrop's network, it allows the user to set the receive time-out span to detect whether the slave station on line or not.

Low byte of R4147 : Port 1 receive time-out span setting (Unit in 10mS).

Low byte of R4159 : Port 1 receive time-out span setting (Unit in 10mS).

Low byte of R4045 : Port 1 receive time-out span setting (Unit in 10mS).

Low byte of R4048 : Port 1 receive time-out span setting (Unit in 10mS).

New message detection time interval setting

1. While the communication port being used as the master or slave of Modbus RTU protocol, the system will give the default time interval to identify each packet of receiving message, if the default works not well, the user can set this time interval through the high byte setting of R4148 and let M1956 be 1, to avoid the overlap of different packet of message frame.

When M1956=1 : High Byte of R4148 is used to set the new message detection time interval for Port 1~Port 4 (Unit in mS)

2. While the communication port being used to communicate with the intelligent peripherals through the FUN151 convenient instruction, if the communication protocol without the end of text to separate each packet of message frame, it needs message detection time interval to identify the different packet. High byte of R4148 is used for this setting.

High Byte of R4148 : New message detection time interval setting for Port 1~Port 4 (Unit in mS).

Without station number checking for FATEK's internal communication protocol

While PLC communicating with WinProladder or Handheld PP, it recognizes the FATEK's internal communication protocol, the quick way to communicate with the PLC is to key in 255 as the station number for WinProladder to connect with the unsured station number of target.

When the number 255 for WinProladder to connect with the PLC, the PLC will communicate with Winproladder even the station number of PLC is 1~254.

Related internal relay

Port	Port Ready Indicator Relay	Finished Indicator Relay
Port1	M1960	M1961
Port2	M1962	M1963
Port3	M1936	M1937
Port4	M1938	M1939

11.4.4 Modem interface setting

High Byte of R4149 = 55H, Remote-Diagnosis/Remote-CPU-Link by way of Port 1 through Modem connection, it supports user program controlled dial up function.

= AAH, Remote diagnosis by way of Port 1 through Modem connection, it supports Passive receiving & Active dialing operation mode

= Other values, without above function

11.5 Description and application of software interface type

11.5.1 Standard interface

The port with the standard interface is controlled by PLC CPU, and the communication transaction of the ports is controlled by FATEK “Standard Communication Driver” or “ModBus Communication Driver”. All accesses to the port must be executed in the format of “FATEK-PLC Protocol” or “ModBus Communication Driver”. FP-07C, WinProladder software package, and many HMI and SCADA have communication drivers conforming to “FATEK-PLC Protocol”, so linkage is built immediate when the “standard interface” port is connected and the hardware interface and communication parameters are consistent. When no such conforming communication driver is available, additional commands that conform to the format of “FATEK-PLC Protocol” or “ModBus Communication Driver” must be written for PLC communication.

11.5.2 Modem-specific interface

R4149 high byte = AAH means that Port 1 is set up to Modem-specific interface. Though CPU uses FATEK “Standard Communication Driver” or “ModBus Communication Driver” to control the communication transaction of Port 1, connection must be made via Modem. In other words, Port 1 is controlled by “Modem Driver” before communication starts, no matter whether active dialup or passive reception connection is concerned, and no access is allowed to PLC. The Modem Driver is only used for Modem connection and transfers the control of Port 1 to FATEK “Standard Communication Driver” when Modem is connected successfully, and Port 1 becomes the “standard interface”. This section discusses the operation of Modem active dialup connection and passive reception connection.

With the Modem-specific interface, the PLC allows Port 1 to dial up a remote Modem actively or receive messages from a remote Modem passively depending on the setting of the internal phone number register (R4140~R4145). When connection of both machines is successful, transmission or reception of data is executed via the phone cable.

A. Passive reception mode

When no “effective phone number” is stored in the internal phone number register of the PLC (see B below), it will enter the passive reception mode and set up the Modem to the reception mode waiting for a remote Modem to dial up. When both machines connect successfully and the inbound signal is correct, the PLC host exits the reception mode immediately and runs into connection state. The remote Modem can fully control and access the PLC host. The PLC host checks the content of the phone number register only at the moment when the power of the PLC host or Modem is turned on (OFF→ON). Therefore, any change to R4140~R4145 (e.g. save or removal of a phone number) is only effective when the power of the PLC host or Modem is turned off and turned on again.

B. Active dialup mode

When an “effective phone number” is stored in the internal phone number register of the PLC host, it enters the active dialup mode at the moment when the power of the PLC host and Modem is turned on. In this mode, Port 1 can dialup a phone number in R4140~R4145 via Modem for connection to the remote Modem corresponding to this phone number. When both machines connect successfully, the PLC host exits the dialup mode and runs into connection state. The remote Modem can fully control and access the PLC host. If dialing fails, the PLC host executes the second dialing to a maximum of three redials (about 3 minutes). If the third redial fails, the PLC host exits the active dialup mode and enters the passive reception mode. It also sets up the Modem to the reception mode waiting for calls from a remote Modem.

Only the phone number that is stored in the Modem phone number register in the following format will be identified as effective by the PLC host. The phone number must be written hex-decimally. Only 0~9 and “E” are meaningful in the hexadecimal digits. “A” stands for dialing delay and is usually used for international calls or extensions of an automatic switchboard. (a “A” is about 2 seconds). “B” stands for “#” (for B.B.Call), and “C” stands form “*”. Among the effective digits, 0~9 is used for phone numbers, while “E” stands for the end of a phone number. Since each register has 4 hexadecimal digits, R4140~R4145 have 24 hexadecimal digits and maximum 23 digits, the end character “E” not counted, can be stored in R4140~R4145. Phone numbers are stored in order from digit 0 of R4140 to digit 3 of R4145. For example, the phone number 02-6237019 is stored in the following order:

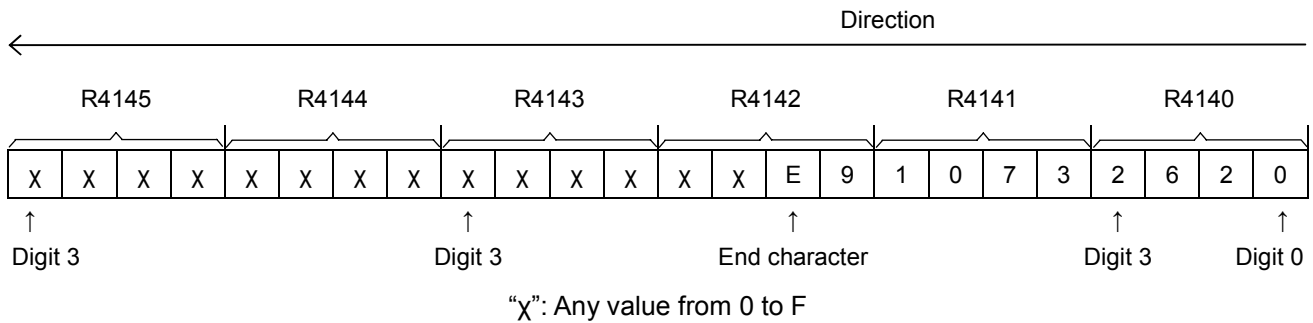

2620H is stored in R4140, 1073H is stored in R4141, and XE9H is stored in R4142. R4143~R4145 can be any value. Please note that the last digit of the phone number must be followed by the end character “E”. The PLC host will ignore the number (any value from 0 to F) behind “E”. Only the value 0~C is acceptable before “E”. Any other values will be regarded as ineffective.

If the telephone bill is paid by the service unit answering the call, no effect phone number should be stored in the internal Modem phone number register of the PLC host, so that it will enter the reception mode when turned on and the service unit will then call the client. If the phone bill is paid by the client, at least one effect phone number must be stored in the internal Modem phone number register of the PLC host, so that it will enter the dialup mode at the moment when the client turn on the power of the PLC host and Modem. Since the phone number of the service unit may change, the WinProladder package provides a phone number Write and Callback command. In this case, the client is not able to call the service unit with the old phone number. To solve this problem, the client may turn on the Modem and PLC host. When the PLC host fails converts to the reception mode after three failed dials (about 3 minutes), the service unit calls the client and imports its new phone number in the Modem phone number register of client’s PLC host and sends a callback command. When receiving the callback command, the PLC host of the client enters the dialup mode immediately and calls the service unit with the imported new number. This application requests the service unit to call the client and pay the bill. However, the amount of the telephone bill is limited because it takes very short time for implementation of the Write and Callback command.

When executing the “Write and Callback” command and connecting to the host of the client successfully, WinProladder will take the old number back from the PLC host for reference (and for future use when write-back of the old number is required) before it writes the new number and executes callback. When the connection is not required any more, WinProladder will give a shutdown command automatically for disconnection.

11.5.3 Ladder program control interface

This type of interface can be set up for Port1~Port4. The ladder program that are used to control the ports are FUN94 (ASCWR), FUN150 (M-BUS) and FUN151 (CLINK).

FUN94 (ASCWR) uses Port 1 as an output interface for ASCII files (transmission only) and sends messages to printers, computers, and other devices that receive messages with ASCII code. The typical application of this command is the connection to printers for Chinese/English reports. WinProladder provides the "ASCII File Editor" function. It converts the data to be edited or printed to ASCII files and stores them in PLC. Production reports, material request reports, and other reports are generated with the help of various dynamic data input during the operation of PLC. Refer to "ASCII File Output Applications" for more information.

FUN150 (M-BUS) controls Port 1~Port 4 and uses them as masters on the ModBus network. The ports can connect to ModBus peripherals (slaves) easily. Refer to the "Convenient instruction for ModBus RTU Master" below for more information.

FUN151 (CLINK) controls Port 1~Port 4 and uses them for resource sharing among PLCs or connection to intelligent peripherals. FUN151 provides four operation modes. Refer to the "FBs-PLC CLINK Applications" below for more information.

11.6 Communication boards(CB)

The FBs-PLC main unit has been built in the communication port 0 , and it can increase the communication ports by purchasing the optional communication board. In response to varying application and demand, 6 types of specification have been designed to suit actual application of customers. In the model name of communication board and communication module, CB signifies Communication Board, CM signifies Communication Module, 2 signifies RS232 interface, 5 signifies RS485 interface, E signifies Ethernet interface. The specification and appearance of every communication board is as follows:

Model/Item		Specification
FBs-CB2		1 × RS232 COM Port (Port 2), with TX · RX indicators.
FBs-CB22		2 × RS232 COM Port (Port 1+Port 2), with TX · RX indicators.
FBs-CB5		1 × RS485 COM Port (Port 2), with TX · RX indicators.
FBs-CB55		2 × RS485 COM Port (Port 1+Port 2), with TX · RX indicators.
FBs-CB25		1 × RS232 COM Port (Port 1) + 1 × RS485 COM Port (Port 2), with TX · RX indicators.
FBs-CBE		1 × Ethernet COM Port (Port 2), with Link · TX · RX indicators.
RS232 specification	Mechanical	DB-9F Standard Plug
	Electrical	EIA RS232 Standard Specification
RS485 specification	Mechanical	3-PIN European style movable terminal platform
	Electrical	EIA RS485 Standard Specification, built-in the terminator with the DIP switch setting.

- 1 × RS232 COM Port [FBs-CB2]

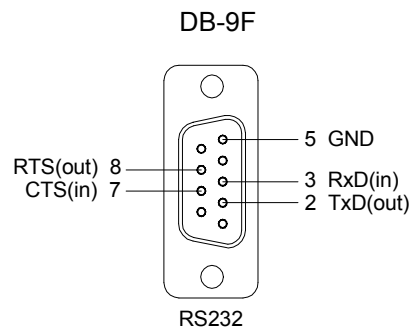
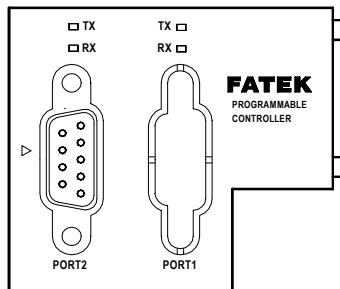

Pin assignment of the connector

- 1 × RS485 COM Port [FBs-CB5]

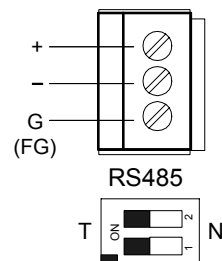
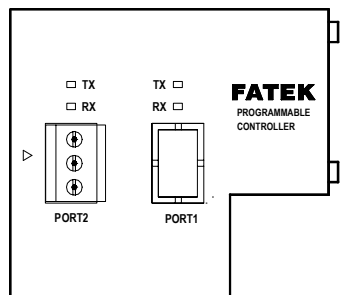

Pin assignment of the connector

- 2 × RS232 COM Port [FBs-CB22]

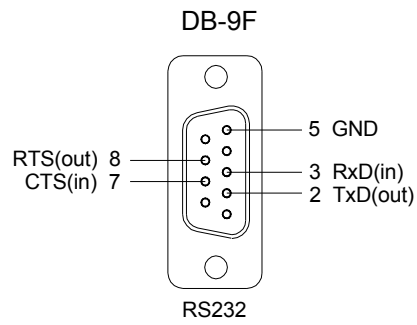
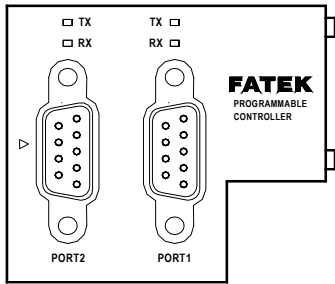

Pin assignment of the connector

- 2 × RS485 COM Port [FBs-CB55]

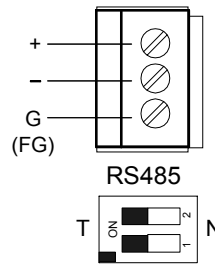
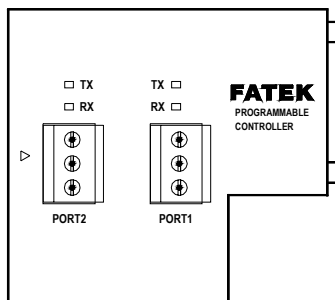

Pin assignment of the connector

- 1 × RS232 + 1 × RS485 COM Port [FBs-CB25]

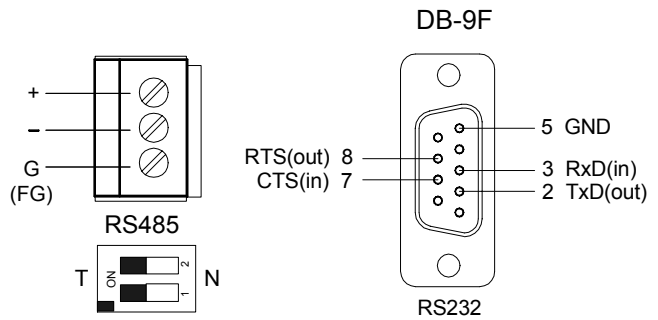
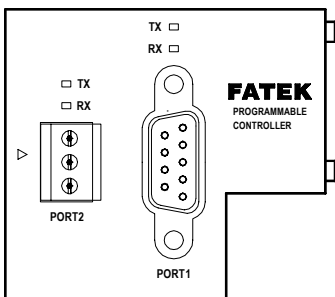

Pin assignment of the connector

- 1 × Ethernet COM Port [FBs-CBE]

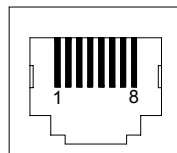
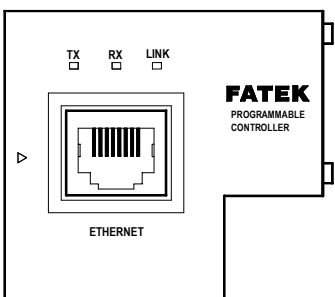

Signal	RJ-45 Pin
TX+	1
TX-	2
RX+	3
RX-	6

Pin assignment of the connector

11.7 Communication modules (CM)

For 3 communication ports application, we need the optional communication board, and we also need the extra communication module for 5 communication ports requirement. The naming system for CM is as described above. CM means communication module, 2 means RS232 interface, 5 means RS485 interface, E means Ethernet interface. The specifications and appearance of each CM is as follows:

Model / Item		Specifications
FBs-CM22		2 × RS232 COM Port (Port 3+Port 4), with TX · RX indicators.
FBs-CM55		2 × RS485 COM Port (Port 3+Port 4), with TX · RX indicators.
FBs-CM25		1 × RS232 COM Port (Port 3) + 1 × RS485 COM Port (Port 4), with TX,RX indicators.
FBs-CM25E		1 × RS232 COM Port (Port 3) + 1 × RS485 COM Port (Port 4) With Ethernet interface, with RUN, Link, TX, RX indicators.
FBs-CM55E		1 × RS485 COM Port (Port 3) + 1 × RS485 COM Port (Port 4) With Ethernet interface, with RUN · Link · TX · RX indicators.
FBs-CM25C		General purpose RS232 ↔ RS485 converter, with RX indicators.
FBs-CM5R		General purpose RS485 amplifier, with RX indicators.
FBs-CM5H		General purpose 4-port RS485 Hub, with ACT, COLLISION indicators.
RS232 specification	Mechanical	DB-9F Standard Plug
	Electrical	EIA RS232 Standard Specification
RS485 specification	Mechanical	3-PIN European style movable terminal
	Electrical	EIA RS485 Standard Specification, built-in the terminator with the DIP switch setting.
Ethernet specification	Mechanical	4-PIN European style movable terminal
	Electrical	10BaseT · IEEE 802.3 standard

* MA main unit does not support expansion of communication modules, therefore it can only have up to three COM Ports

- 2 × RS232 COM Port

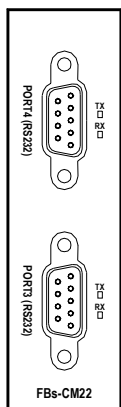

{ FBs-CM22 }

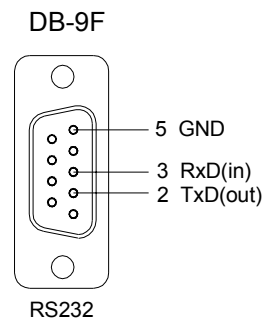

Pin assignment of the connector

- 2 × RS485 COM Port

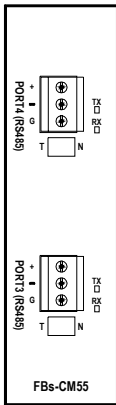

[FBs-CM55]

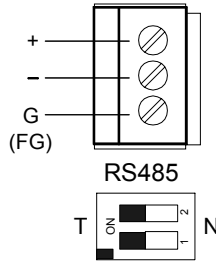

Pin assignment of the connector

- RS232 + RS485 COM Port

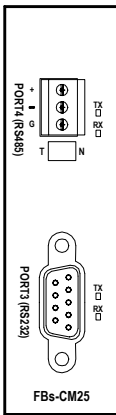

[FBs-CM25]

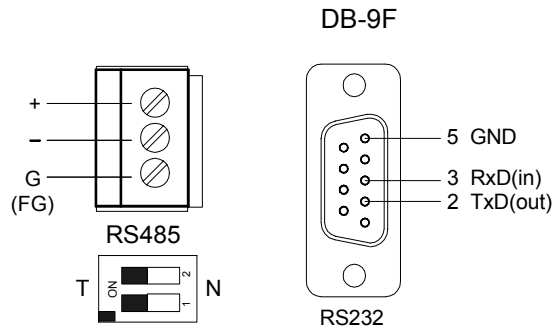

Pin assignment of the connector

- 2 × RS485 COM Port + Ethernet

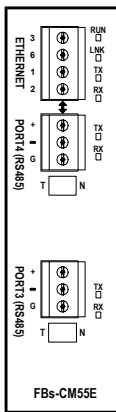

[FBs-CM55E]

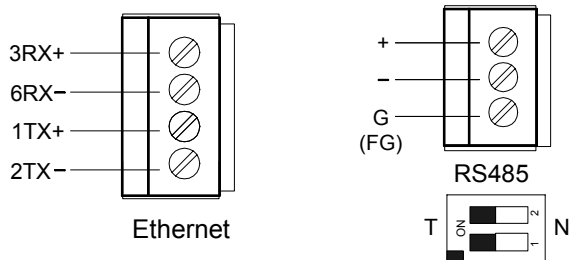

Pin assignment of the connector

- RS232 + RS485 + Ethernet

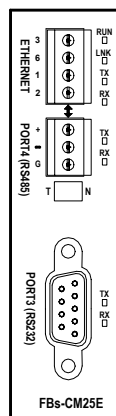

[FBs-CM25E]

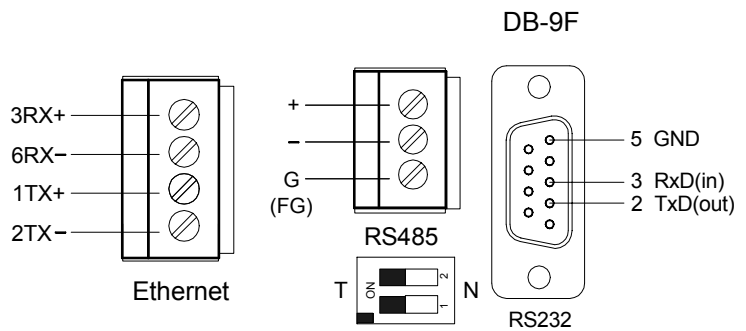

Pin assignment of the connector

- RS232 ↔ RS485 Converter

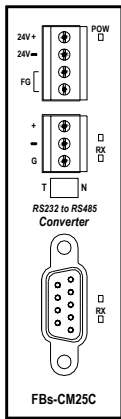

[FBs-CM5C]

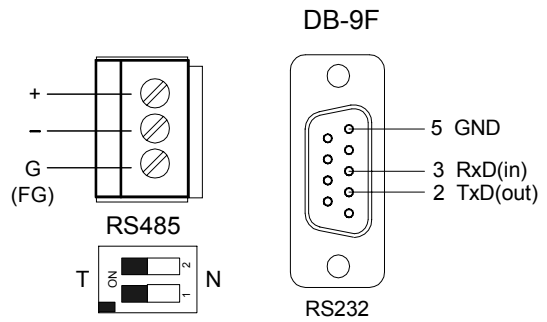

Pin assignment of the connector

- RS485 Repeater

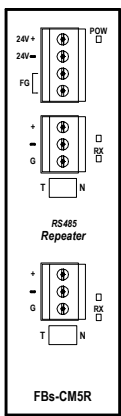

[FBs-CM5R]

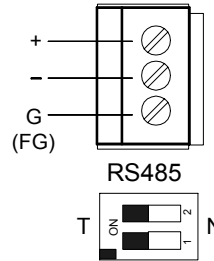

Pin assignment of the connector

- RS485 HUB

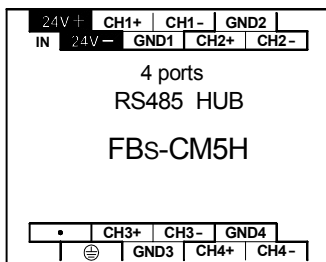

[FBs-CM5H]

11.7.1 4-port RS485 central hub (FBs-CM5H)

FBs-CM5H is the 4 ports RS485 central Hub. This module is not restricted to be used on FBs-PLC series products, and it can be used by the wide range application of RS485 communication interface. This product can function as a repeater, and it can support the star topology for wiring connection except the traditional RS485 bus topology. In addition, the ports are designed with opto-electric insulations to protect the system from disrupted current generated by the difference in earth current. Another feature is the direction change control utilizes automation to adjust in accordance with different data transfer rate and data format. Installation is easy and it can be directly fixed onto DIN-Rail or fixed with screws. For details of the wiring method for FBs-CM5H, please refer to chapter 11.3 (RS485 COM Port hardware wiring notes)

Indicators

Indicator Name	Functional Description
POW	Power indicators. This indicator will light up when there is external power source.
ACTIVE	Four LED indicators represent the activities of the four ports. The ports with indicators on are active ports, and the others are passive ports. Messages on active port will appear on passive port.
COLLISION	Four LED indicators represent the signal collision status for the four ports. The ports with indicator on mean the signal transmitted online and the signal to be transmitted on the ports are inconsistent, which also mean there are other devices transmitting signal on the bus causing conflicts.

Setting for terminator

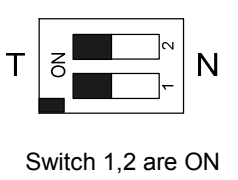
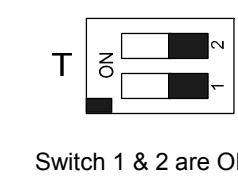
Port No.	Switch	Terminator ON	Terminator OFF
CH1	SW1		
CH2	SW2		
CH3	SW3		
CH4	SW4		

⚠ Warning

- The DIP switch for terminator setting must be used with the 2 bits together (both "ON", or both "OFF"), the two bits can not be inconsistent, otherwise it would cause bad or worsen communication.

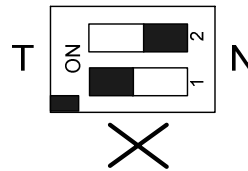
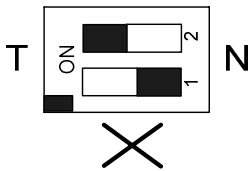

Working mode settings

- Symmetrical mode : Function of every port is the same. Signal received by any one port would transmit to the other ports.
- Asymmetrical mode : Port 1 is the master, and signals received by it will be transmitted to other ports, but signal received by port 2~4 would only transmit to port 1.

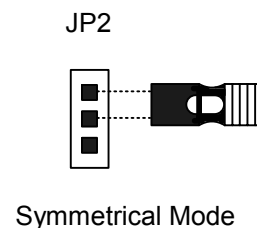
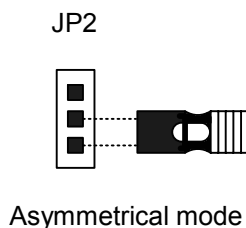

11.7.2 Isolated RS485 repeater (FBs-CM5R)

FBs-CM5R is the universal RS485 repeater. This module is not restricted to be used in FBs-PLC series products only, it can also be used in wide range of RS485 interface application. The feature of this product is the opto-electric insulation design between the two RS485 ports, protecting system from disrupted current caused by difference in grounding potential. Installation is very convenient, just fix it directly onto DIN-Rail or screw it on.

Setting for terminator



11.7.3 Isolated RS232/RS485 converter (FBs-CM25C)

FBs-CM25C is the interface signal converter between RS232 and RS485 network. This module is not limited to be used on FBs-PLC series products, it can be used as the universal converter between RS232 and RS485 interface. The feature of this product is the opto-electric insulation design between the two ports, protecting system from disrupted current caused by difference in grounding potential. Another feature is the direction change control utilizes automation to adjust in accordance with different data transfer rate and data format. Installation is very convenient, just fix it directly onto DIN-Rail or screw it on.

Setting for terminator

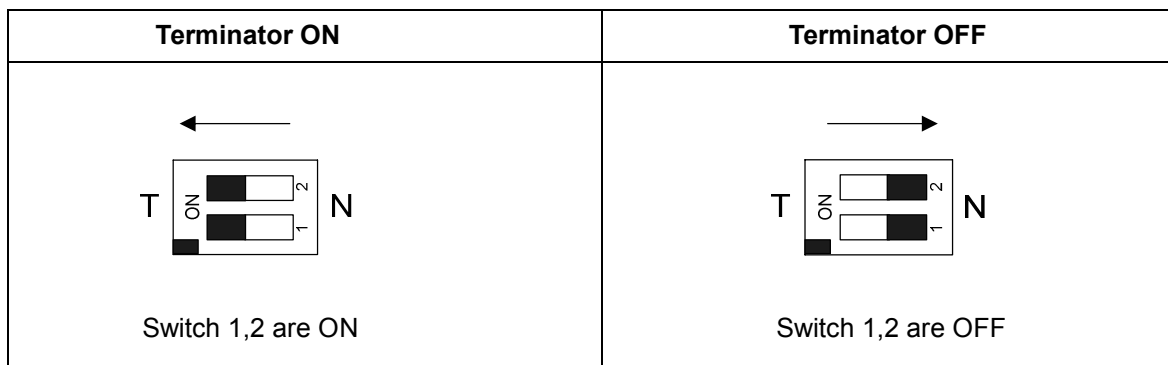

11.8 FBs ethernet communication module and application

Network communication has far reaching applications and is helpful for the circulation of information. Though most of the software systems are designed for commercial use, the CIM application in the manufacturing industry and the ongoing development of the Internet speed the application of network communication in industries. In the circumstances, FATEK develops a series of Ethernet/Serial Port Bridge Module as a cost efficient and effective FBs-PLC network connection solution for customer.

The FBs-CBE module only provides connection of the Ethernet to FBs-PLC. Other modules (CM25E/CM55E) provide two serial ports Port 3 and Port 4 for communication applications. Port 4 is only used in conjunction with RS485 for Ethernet signal transformation, while Port 3 is used for other peripheral control purposes.

11.8.1 Specifications

11.8.1.1 Connector specifications

Module	Port	Signal Type	Connector Type	Power Consumption*
FBs-CM25E	Port3	RS232	DB9 female	200mA
	Port4	RS485	European 3pin connector	
	Ethernet	10BaseT	European 4pin connector	
FBs-CM55E	Port3	RS485	European 3pin connector	200mA
	Port4	RS485	European 3pin connector	
	Ethernet	10BaseT	European 4pin connector	
FBs-CBE	Ethernet	10BaseT	RJ45	150mA

* : CPU 5V power source

11.8.1.2 Ethernet specifications

Feature	Description
Network interface	10BaseT, IEEE 802.3
Transmission Protocol	TCP, UDP, IP, ARP
Application Protocol	FATEK/TCP/UDP, ModBus/TCP
Status indicator	Link status indicator (LINK), transmission status indicator (TX), receiving status indicator (RX)
PLC port	Port4 (CM25E/CM55E)
	Port1 & Port2 (CBE)
PLC baud rate	9600,19200,38400,57600,115200,230400(CM25E/CM55E)
	115200(CBE)

Feature	Description
Security	Use permitted IP for access control
Building tools	Windows Network Building Software
Application modes	Server and Client modes
Permitted IPs	10
Port mapping group size	18
TCP connections	Max. 8 connection at a time (only for the Server mode)

11.8.2 Appearance

11.8.2.1 CM25E and CM55E appearance

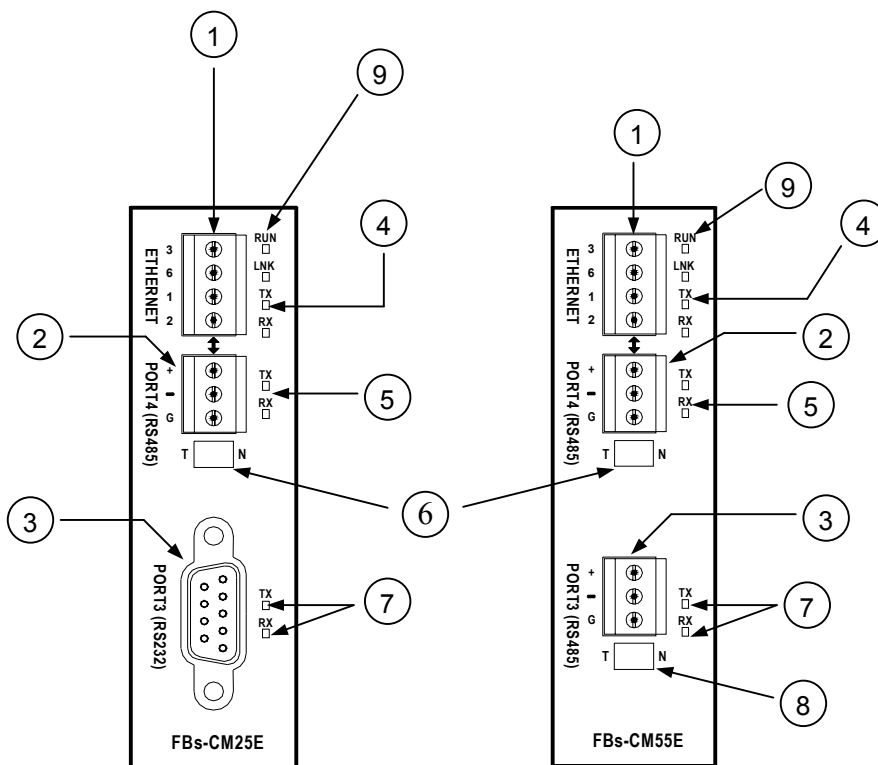

- ① Ethernet connector : Instead of traditional RJ-45, European 4pin connector with excellent contact is used for the vibration environment of the machine.
- ② Port4 connector : For RS485 signal.
- ③ Port3 connector : For RS485 signal (FBs-CM55E) and RS232 signal (FBs-CM25E).
- ④ Ethernet status indicator :
 - LINK : ON indicates that normal connection.
 - RX : ON indicates that the module senses messages in the Ethernet.
 - TX : ON indicates that the module is sending messages to the Ethernet.

- ⑤ Port4 status indicator :
 RX : ON indicates that Port 4 is receiving messages.
 TX : ON indicates that the Port 4 is sending messages.
- ⑥ Port4 terminating resistor switch : This switch is used to control the connection of the terminating resistor in the module to Port 4 RS485 interface. T means with terminating resistor. N means Without terminating resistor.
- ⑦ Port3 status indicator :
 RX : ON indicates that Port 3 is receiving messages.
 TX : ON indicates that the Port 3 is sending messages.
- ⑧ Port3 terminating resistor switch : This switch is used to control the connection of the terminating resistor in the module to Port 3 RS485 interface. T means With terminating resistor. N means Without terminating resistor.
- ⑨ Module status indicator (RUN) : Quick flashing indicates normal operation. Slow flashing indicates active setup.

11.8.2.2 CBE appearance

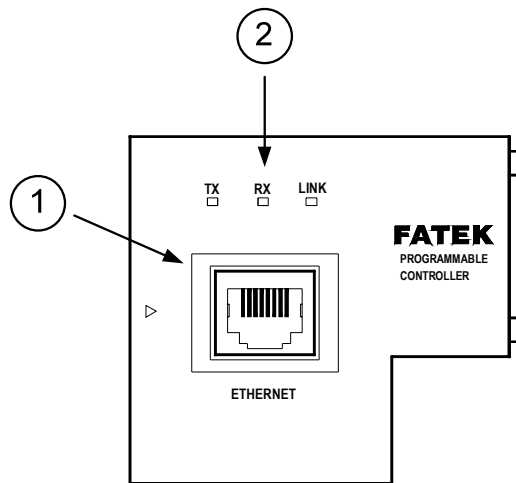

- ① Ethernet connector: Standard RJ45 connector.
- ② Ethernet status indicator:
 LINK: ON indicates normal connection.
 RX: ON indicates that the module senses messages in the Ethernet.
 TX: ON indicates that the module is sending messages to the Ethernet.

11.8.3 Serial connector function

Port3 connector

The signal level of Port3 connector is of RS232(CM25E) or RS485(CM55E). This port can be treated as a general communication port of FBs-PLC module and used for peripheral applications.

Port4 connector

The signal level of Port4 connector is of RS485(CM55E). The main function of this port is to couple the Ethernet signal to FBs-PLC module, this port also can be treated as a general communication port of FBs-PLC module and used for peripheral applications. Whenever the FBs-CMX5E module receive a data packet from the Ethernet interface, the same data packet also will appear at this port(Ethernet to serial port conversion). On the contrary, if a data packet is received at this port and the destination is due for network (by lookup mapping table), it will also appear at Ethernet network. Because the multi-drop characteristic of RS485 interface, install one FBs-CMX5E can provide more than one PLC to hook on Ethernet.

11.8.4 The function of Ethernet serial converter

The operation principle of Ethernet serial converter is to take this module as interface and receive all the messages from network that intend to the PLCs managed by this module then convert it to the serial signal that can be accepted by PLC and transmit it thru port4. The operation is completely transparent, in other words, The FBs-PLC cannot distinguish the message is from local or network, the reply message is the same with normal RS232communication. When the FBs-CMX5E or FBs-CBE module(for clarity it will be referred as Ethernet module in following context) receives the reply message of PLC will pack the message into network data packet then send it to the network. It must emphasis here that the network environment is complicated and not adequate for real time data transfer and can be use mainly for monitoring but not for control. The main reason to use the network for factory communication is for its connectivity. The application, which required to access one processor at same time by multiple clients, previous was difficult to implement by RS232 and RS485 can now easily achieve by network solution.

11.8.5 Application architecture

Base on the different requirements of network application this module provides two operating modes –Server Mode and Client Mode.

When operates at server mode, the Ethernet module will wait for the message coming from the network. After decode the received message it will send the message thru serial port to the PLC main unit. The reply message from the PLC will intercept by this module and packed into data packet then transmit to the network hence complete a server mode transaction.

When operates at client mode, the Ethernet module will wait for the message coming from the serial port. If the received message is for the PLC located at the remote site connected by network, the Ethernet module will pack the message into data packet for network transmission and send it to network. After send the message to network the Ethernet module will wait for the reply message coming from network, when it receives the reply message it will direct the message to serial port for PLC hence complete a client mode transaction. The network connection of Ethernet module depicted in the figures at following chapter, for clarity, will only be drawn by a direct link. Actually the network interface of the Ethernet module is 10BaseT, which should attach with Hub in order to connect with network.

11.8.5.1 Server mode

When operates at server mode, the direct connected single PLC or the stations connected by RS485 are all work at slave mode, which will wait for command message passively and reply the command. Follows are example of server mode application.

Single FBs-PLC connection

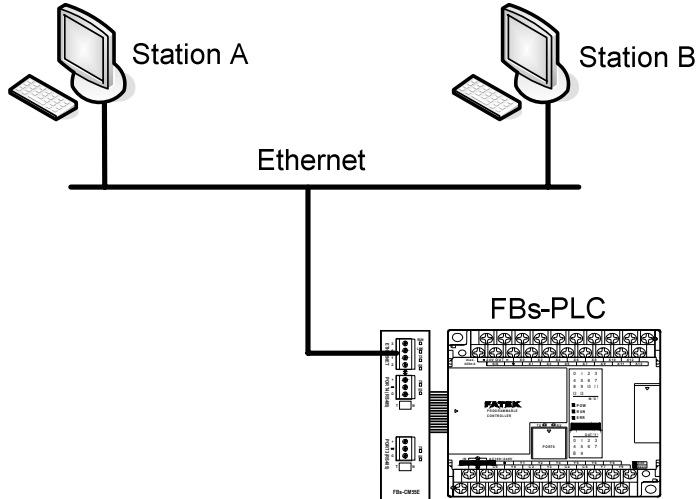

The example illustrate on above is the simplest server mode application. Work station A and work station B are master that can send the command message actively to FBs-PLC, Upon receiving the command message, Ethernet module will send the message thru the port4 to FBs-PLC. When there are more than one message intended to send to FBs-PLC, the Ethernet module will save the additional messages into the message queue then send it to FBs-PLC in orders (Must wait for the reply message before send the next command) therefore there will no conflicts.

When work at this mode, there is no need to write any program in PLC for operation.

Multiple PLC connection

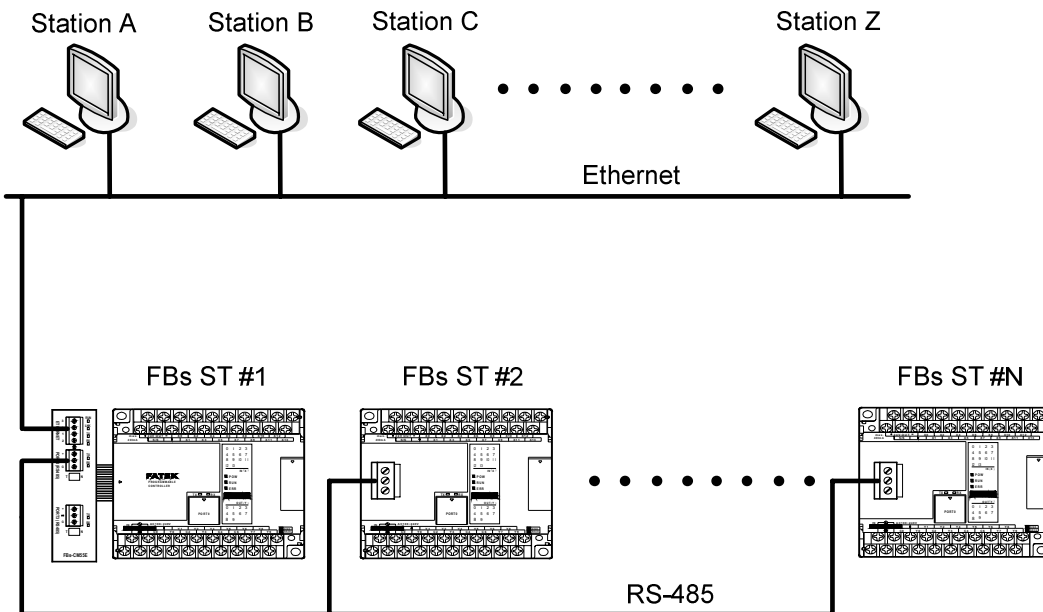

Under this application architecture, The PLCs connect the Ethernet module with the RS485 interface of port4. The work station A and work station B are master that can send the command message actively to FBs-PLC, Upon receiving the command message from the network, Ethernet module will re-send the message to FBs-PLC thru port4 interface. When the message appears at RS485 line, each PLC will compare the target station embed in message against its own station ID. If the result is true then it will reply according to the command message. The reply message will intercept by the Ethernet module and re-pack then send to the network. When there are more than one message intended to send to FBs-PLC, the Ethernet module will save the additional messages into the message queue then send it to FBs-PLC in orders (Must wait for the reply message before send the next command) therefore will not have conflicts. When work at this mode, there is no need to write any program in PLC for operation.

11.8.5.2 Client mode

While work at client mode, the Ethernet module will wait the command message at port4. When it finds the message is for the PLC station located at remote site then it will pack the message according to the content of port mapping table and send it to the network. After that, Ethernet module will keep an eye on network for the reply message. Upon receiving the reply message, the Ethernet module will decode the message then send back to PLC thru serial port hence complete a client mode transaction. When work at this mode, the direct connected single PLC or the master station of PLC LINK connected by RS485 interface are all operated at master mode, which means it use LINK instruction mode0 to send the command actively. The client mode also can be further divided into standard mode and virtual server mode. Explanation as follows.

Standard mode

When work at this mode, the master PLC connected with Ethernet module can use LINK instruction mode0 send the command message to other PLC. The target PLC that master PLC intend to command can be a local slave PLC connected by RS485 interface to master PLC or a PLC located at remote site with sever mode Ethernet connection. There is a "Station to network address translation table" in the Ethernet module when work at client mode. This table includes the information about the mapping of local station and remote station, the user should set this table according to the actual application deployment. While operation, the Ethernet module will constantly inspect the received message, if the station number in the message can be found in the translation table that means the message is going to route to network, the Ethernet module will first replace the station number in message according to the translation table then re-calculate and update the check sum of translated message and encapsulate it in network data packet and finally send it to the network. After received the reply message from network, the Ethernet module will perform the translation of message at the reverse order. First it will replace station number in message to the original station number and then re-calculate and update the check sum of message then send it to serial port. A standard client mode network application is shown as follows.

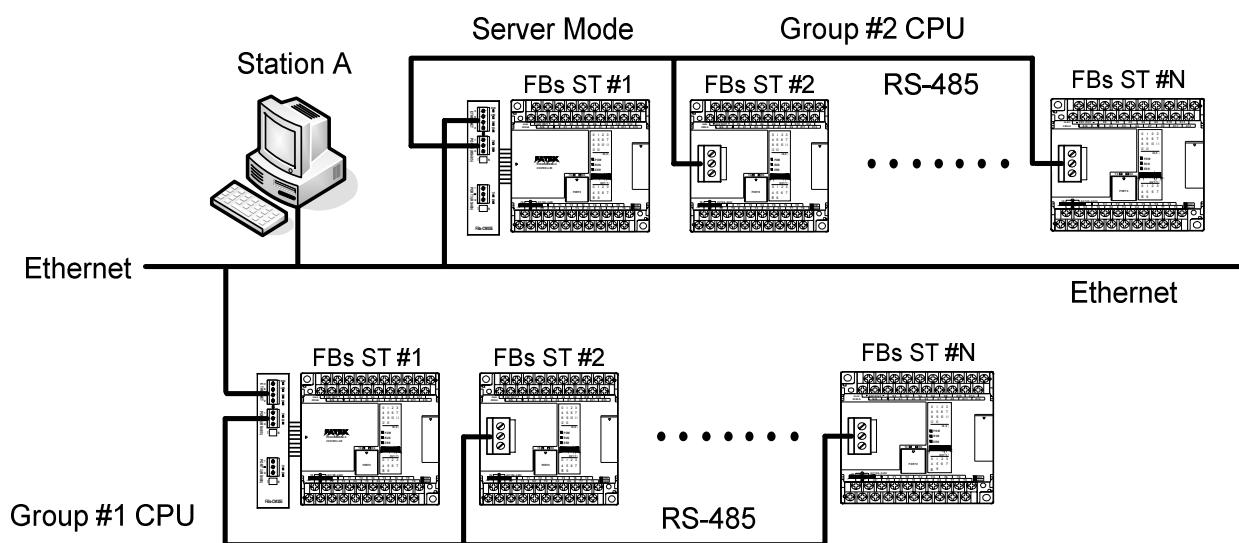

In the above figure, there are two groups of PLC. The PLCs in each group are linked together by RS485 interface and then attach to an Ethernet module for network accessibility. The station number 1 of group 1 is a master PLC, which not only can access the other PLCs of same group but also can access the PLCs of group 2 with the help of two Ethernet modules bridging. The Ethernet module attached to group 2 PLC is configured as server mode, which means all the PLCs covered by this module are work as slave PLC and wait for the command passively. It must emphasis that the PLCs under standard client mode Ethernet module can't access by other master devices thru network communication. The role of this kind of Ethernet module is very similar to Fire Wall. Only the messages from inside or the corresponding reply messages can be accepted by Ethernet module, other messages will be blocked. The security of client mode operation is very high. Based on the reason described above, the workstation A can only access the PLCs of group 2. It's noted that, from the view point of master PLC, the station number of station #2 of group 2 is not 2, otherwise it can't distinguish it from the local station of #2. This can be overcome by the introduction of translation table.

Virtual server mode

Though high security is the key feature of standard client mode, can't accessed by other devices thru network is also a drawback. To take the balance between the security and connectivity, the Ethernet module provides a virtual server mode to meet the both end. While working at this mode, the Ethernet module emulates a PLC with station number of 255. There are only R0~R1999 can be accessed of this virtual PLC. When the command message is for station 255, the Ethernet module will interpret the message and act upon that message; this is true for all the messages whether it comes from serial port or from network. The Ethernet module act as a medium, the status of PLCs can store in it for outside world access. The outside world can put the command status in it for PLCs access. The virtual server mode is an option for client working mode, which means while act as virtual server the master PLC still can access the slave PLCs that attached to network.

11.8.6 Hardware installation

DIP switch settingTermination resistor installation(FBs-CM25E/CM55E)

In order to meet the termination requirement of RS485 network, all Ethernet modules equip with a set of built-in termination resistor to ease the field installation. The termination function can be setup by the DIP switch seen from the front cover as follow.



When both switches are at T position, it means termination resistor is in effective. When at N position means no termination resistor attached by this module. When implementation, there are only two modules that located at opposite far side need to terminated. Excessive termination will over load the whole network thus must be avoided.

Password protection setup

When the password has been entered (enabled), the user will be requested to enter a matched password each time when perform the configuration via configuration utility 'ether_cfg.exe'. In other words, in case the user forget the password then he/she no longer can modify the module's configuration. To prevent this situation from occurring, there also provides a jumper to disable the password protection temporary. This jumper can be accessed only when the module's plastic cover is removed. The relative location of jumper is depicted at follow :

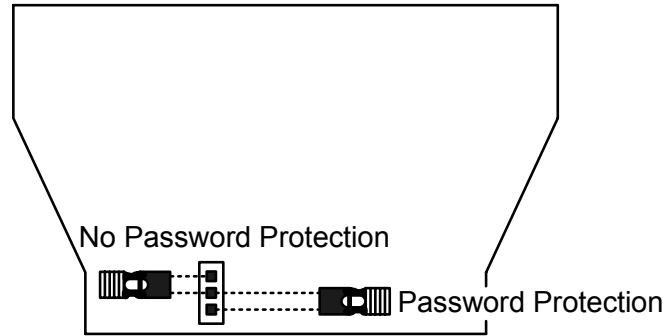

When the jumper cap of JP1 is at upper position (linked by white line), the password protection is disabled. The jumper cap should put in the lower position when under normal operation.

Cable wiring

Serial Port Connectors : Please refer Appendix A, B for the Port3, Port4 signal description.

Network Connect : The connector type of FBs-CM25E/55E is Euro 4pin plug connector while FBs-CBE board is RJ-45. Please use the CAT5 UTP (un-shielded twisted pair) cable for network connection. The best recommendation is using the CAT5 STP(shielded twisted pair) cable

The wiring of cable to network connector is listed as below :

Signal	Line Color	European Pins	RJ-45 Pins	Direction
TX+	White orange	3	1	External ← PLC
TX-	Orange	4	2	External ← PLC
RX+	White green	1	3	External → PLC
RX-	Green	2	6	External → PLC

11.8.7 Software setup

There is a accompany software "Ether_cfg.exe" to aid the configuration of Ethernet module. This software is a windows-based software and has following functions :

- 1. Basic module Information setup** : Includes IP (Network address), gateway, netmask, baud rate, operating mode, module name, module description.
- 2. Security setup** : Setup authorized IP. With this function, only the command message issue by the host with authorized IP can be accepted by Ethernet module. Hence can prevent the unintended access and keep the system secure. There are 10 set of IP group can be set. Each group can contain one or more consecutive IPs.
- 3. Local station to remote station mapping** :

The operating of FBs-PLC networking is purely transparent. When access the remote slave PLC by executing the LINK instruction of mode0 and with the help of Ethernet module, the master PLC does not know the remote PLC is connected by network. In other words, the maximum number of slave station is still 254. When Ethernet module work at client mode, in order to translate the local station into remote station, must first setup the translation table. Considering the convenience for variety application, there are three methods can be used to setup the network configuration.

4. Setup by local area network :

This is the most convenient method for network configuration. When operating, the configuration software will scan all the Ethernet modules attached to the network. All the scanned Ethernet modules will be shown in the table on the screen with the regarded basic information. The user can pick the Ethernet module to be editing directly from the screen. Considering the security, we can set the password to prevent the unintended access.

5. Setup by internet :

With this method can setup the network configuration thru Internet. Most often is used to setup the station mapping or authorized IP. While use this method, can only setup one Ethernet module at a time and must specify the IP address of Ethernet module to be edited. Considering the security, can set password to prevent the unintended access.

LAN configuration

Step 1 : Use the network cable to connect the Ethernet module and Hub.

Step 2 : Connect the PC to network and execute the software - Ether_cfg.exe. Use the mouse click the 'Intranet' option in the 'Configuration Channel' group box, then the screen changes to

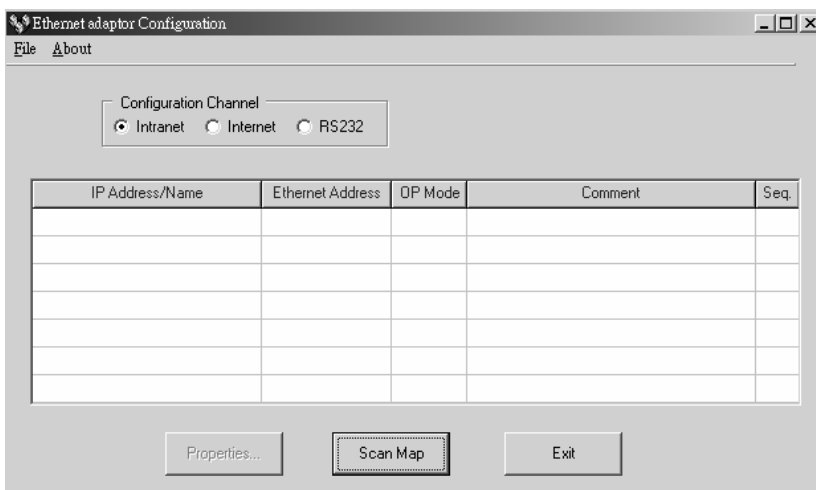

→ Click the 'Scan Map' button then start the scanning of Ethernet module. All the modules detected will be shown in the table.

Internet setup

Step 1 : Connect the Ethernet module and Hub with twisted Ethernet cable.

Step 2 : Connect the PC to network and execute the network configuration software - ether_cfg.exe. Use the mouse point to the 'Internet' option buttons within the 'Configuration Channel' group box and click it then the screen will be shown as below

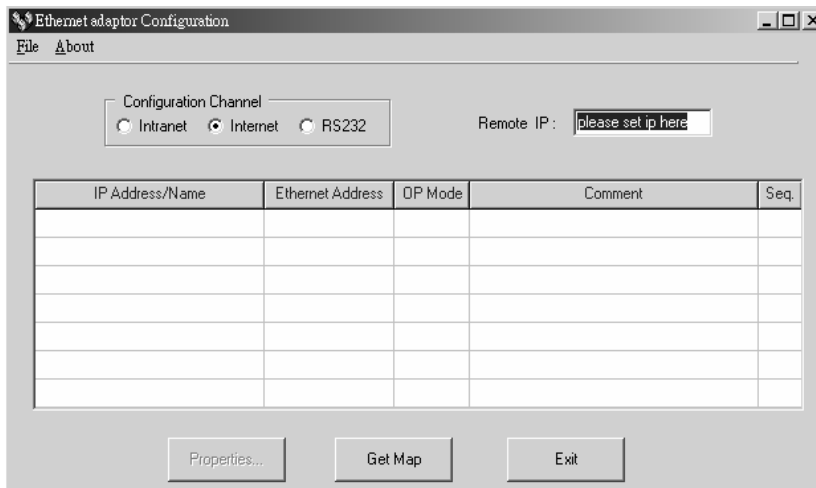

At this time can input the remote IP address of the Ethernet module desired for configuration. After click the 'Get Map' button, it will start to connect Ethernet module. When the connection is established will show the information regard the connected Ethernet module in the table at the middle of window.

Common data setup

Whenever the connection is established, it will show the information regard the connected Ethernet module in the table at the middle of window, no matter what the connection method is selected.

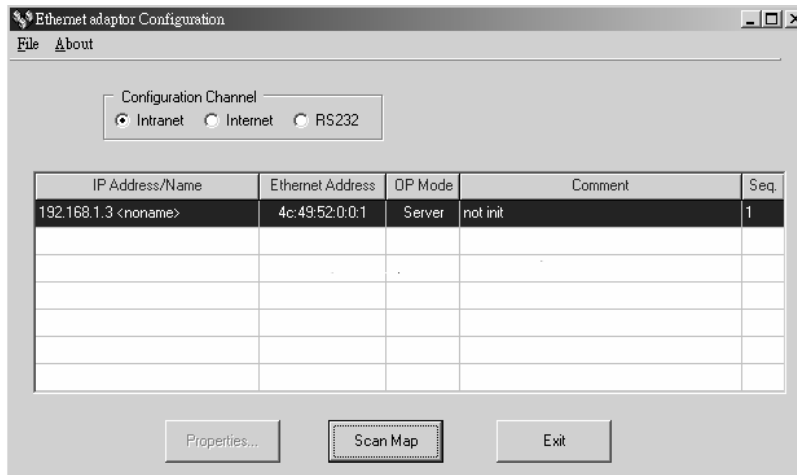

At that time, can double click the line where the desired Ethernet module is located or single click the line and click 'Properties..' button to perform the configuration. If password not setting or correct password were entered will show the screen as below

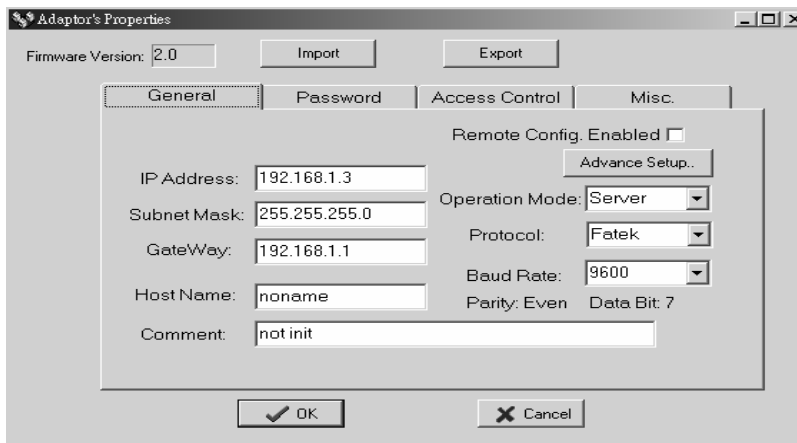

Follows are the description of each field shown in above :

- 1. **Firmware Version** : Denotes the software version of Ethernet module for configuration.
- 2. **IP Address** : IP address of Ethernet module for configuration.
- 3. **Subnet Mask** : Subnet mask of Ethernet module for configuration.
- 4. **GateWay** : The IP address of gateway for Ethernet module for configuration.
- 5. **Host Name** : For documentation, can be used to distinguish Ethernet module. At most can consist of 11 characters.
- 6. **Comment** : For documentation, can be used to distinguish Ethernet module. At most can consist of 21 characters.
- 7. **Operation mode** : Client or server mode selection.
- 8. **Protocol** : There are two communication protocols were supported in this module. **Modbus/TCP** or **Fatek**. **Modbus/TCP** can be choosed only when the operation mode is set to Server mode while the Fatek mode can be used in both modes.

9. Baud Rate(CM25E/CM55E) : Communication speed between Ethernet module and PLC with 9600、19200、38400、57600、115200、230400 bps six options.

10. Remote Config. Enabled : For security, when this option is checked will allow the configuration thru the Internet. It must be checked when intent to configure the network configuration according to the method described in section 5.3.4. It's strongly recommended to set the password when enable the remote configuration to prevent the leakage of security hole. Please leave this option un-checked if remote configuration is not necessary.

11. Import/Export button : Can use the Export function to save entire setup data of Ethernet module to file or use the Import function to retrieve the setup data stored in file to ease the editing job of configuration.

※ The contents enclosed in the box at below can be skipped for the beginner.

Advance Setup : Advanced Setup: This setting can only need to be performed when at server mode, click 'Advance Setup' button to start setup and the screen will be shown :

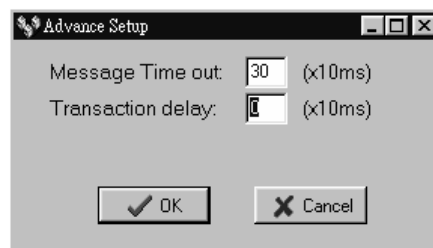

Message Time Out : The time-out time for PLC, the default setting is 300ms. Ethernet module will wait for the same amount time of this field before the PLC can reply the command message.

Transaction delay : The minimal delay time for Ethernet module to send the next command message after it receives a reply message from PLC. The default setting is 0ms. This setting is used for the applications that connect multiple PLCs with diverse scan time by RS485.

Security setup

For security of Ethernet module operation, besides the disable/enable control of remote configuration, also provides following measures to work with

Password protection : Continues from last screen, click the 'Password' tab to set the password. The screen changes to



Please input the new password at 'New Password' and 'Confirm Password' edit field and click the 'Change' button to complete the setting of new password. Please click the 'Remove' button if password protection is not necessary.

The setting of access right : Use the setting of authorized IP to prevent the illegal access of data. After click the 'Access Control' tab, the screen changes to



Move the cursor to the 'Grant IP' table and click the right mouse button then the screen will appear a pop-up menu as shown below :



... .. Click 'Add' to add one set of authorized IP. Click 'Del' to delete a set of authorized IP. Click 'Edit' to modify an existed authorized IP data. After click the 'Add' function the screen changes to

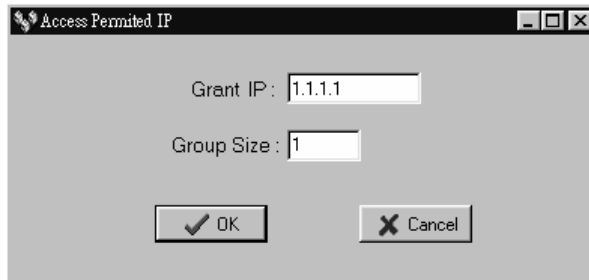

With this dialog to define a set of consecutive authorized IP addresses. Please input the first IP address of the consecutive IP addresses in the 'Grant IP' field and input the size of IP addresses in 'Group Size' filed

Port mapping setup

This setting can only need to perform when Ethernet module is work at client mode. When the working mode is set to client mode the basic configuration data page changes to

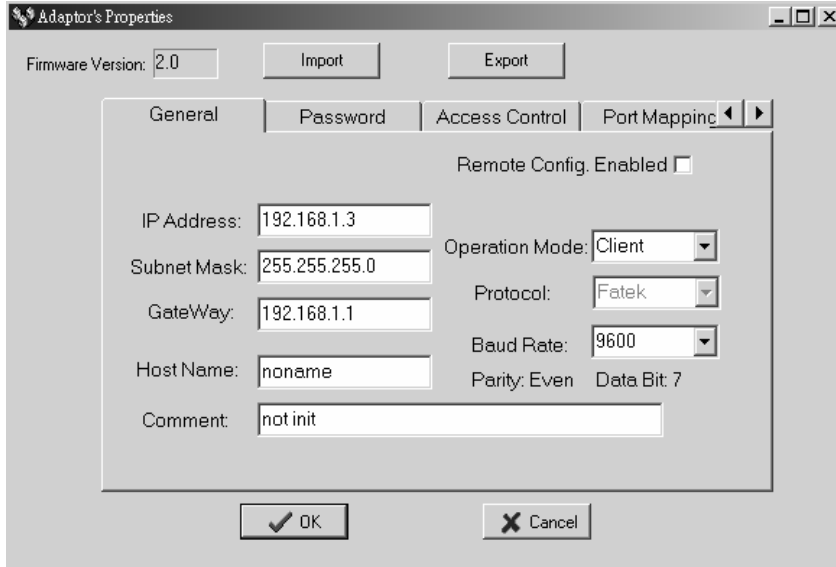

It has an additional 'Port Mapping' tab when compare with server mode, after click the 'Port Mapping' tab the screen changes to

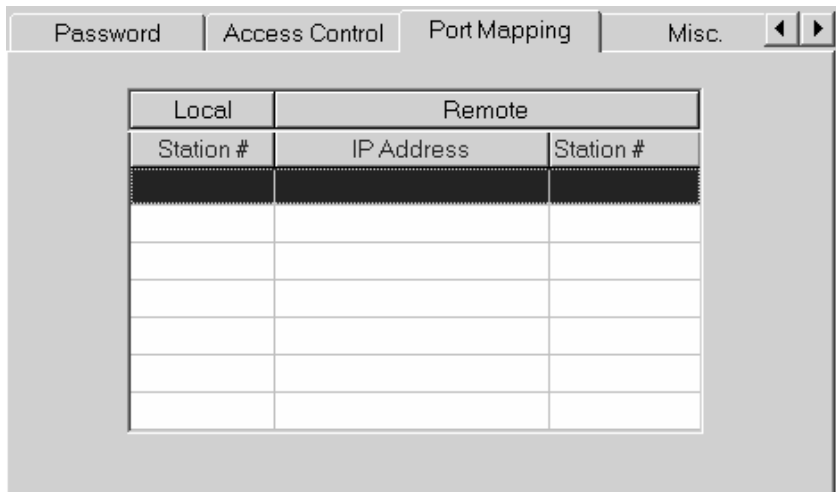

Move the cursor to the table locating in the center of window then click the right mouse button then the screen appears a pop-up menu as shown below :

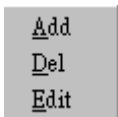

... .. Click 'Add' to add one station mapping data. Click 'Del' to delete a station mapping data. Click 'Edit' to modify an existed station mapping data. After click the 'Add' command the screen changes to

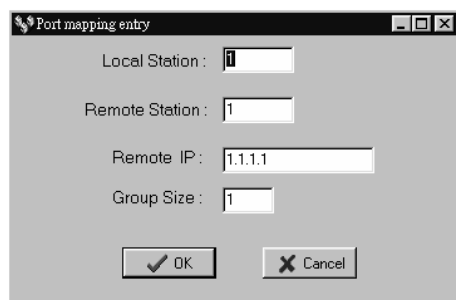

Following are the description of each field shown in above :

1.Local Station: The station number of local PLC.

2.Remote Station: The station number of remote PLC.

3.Remote IP: The IP address of Ethernet module connected by the remote PLC.

4.Group Size: With execute this dialog once can define a group of station mapping, for example, if we want to map the local PLC station number 20~29 to remote PLC station10~19 and the IP Address of remote Ethernet module is 192.168.1.3 then can set the Local Station to 20, Remote Station to 10, Group Size to 10, Remote IP to 192.168.1.3. The Ethernet module can provide at most 19 groups of station mapping.

Service port setup

The screenshot shows a configuration window with four tabs: 'General', 'Password', 'Access Control', and 'Misc.'. The 'Misc.' tab is active. It contains two sections: 'Fatek Service Port Number' and 'ModBus Service Port Number'. Each section has two input fields: 'Major Port' and 'Secondary Port'. In the 'Fatek' section, both fields are set to '500'. In the 'ModBus' section, both fields are set to '502'.

The Ethernet module when work either in TCP or UDP server mode should be assigned a service port number for client access. The default port number for FBs series Ethernet module is port 500. If the user want to change the port number can click the 'MISC' tab and change the Major port field to desire port number. Second port field provides the UDP working mode the opportunity to have dual service port number, one is port 500 the other is port number appear in Major port field.

Update configuration

When finish the editing of configuration data, please click the 'OK' button of the "adaptor's properties" window to update the Ethernet module. When finish the update and without error, the screen will change to main window and ready for configuration of another Ethernet module.

11.8.8 Procedures to change the configuration

Now summarize the procedures to change the network configuration at below.

Step 1: Select a connection method. (LAN or Internet)

Step 2: Edit the basic data of the module.

Step 3: Set the password protection (optional).

Step 4: Setup the authorized IP (optional).

Step 5: Setup the mapping of local and remote station and IP address (Only client mode required).

11.8.9 Pin assignments and protocols

RS232 port pin assignments

Signal	Pins	Direction
RX	2	External→PLC
TX	3	External←PLC
GND	5	

RS485 port pin assignments

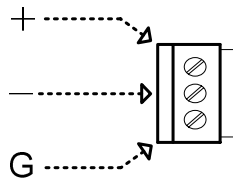

FATEK TCP/UDP communication protocol

The communication protocol of FATEK TCP/UDP embeds the FATEK serial communication message in the TCP or UDP data packet. The port number used to convey the FATEK TCP/UDP message is configurable (default is 500.)

ModBus/TCP communication protocol

The document of communication protocol of Modbus/TCP can be referenced at the web site <http://www.modbus.org> . The port number used to convey the Modbus/TCP message is 502.