

**CSCA0101
COMPUTING BASICS**

**Chapter 2
Basic Computer Configuration**

Basic Computer Configuration

Topics:

- Basic Operations
- Computer Components
- Computer Categories

Basic Computer Configuration

Computing Terminology

Data

- Data is anything in a form suitable for use with a computer.

Information

- Refer to processed data.

Program

- Computer instructions.

Basic Computer Configuration

Three Basics Kind of Computer

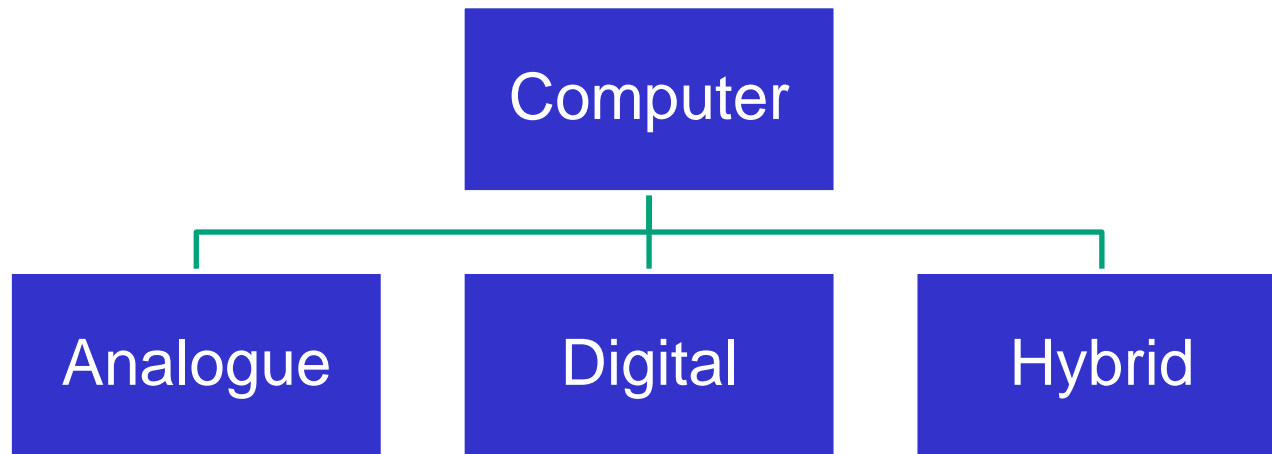

Basic Computer Configuration

Three Basics Kind of Computer

Analogue Computer

- Analog computers are used to process analog data. Analog data is of continuous nature and which is not discrete or separate.
- Such type of data includes temperature, pressure, speed weight, voltage, depth etc.
- These quantities are continuous and having an infinite variety of values.

Basic Computer Configuration

Three Basics Kind of Computer

Digital Computer

- A Digital Computer works with digits to represent numerals, letters or other special symbols.
- Digital Computers operate on inputs which are ON-OFF type and its output is also in the form of ON-OFF signal.
- Normally, an ON is represented by a 1 and an OFF is represented by a 0.
- A digital computer can be used to process numeric as well as non-numeric data.

Basic Computer Configuration

Three Basics Kind of Computer

Hybrid Computer

- A hybrid is a combination of digital and analog computers.
- It combines the best features of both types of computers, i-e. It has the speed of analog computer and the memory and accuracy of digital computer.
- Hybrid computers are used mainly in specialized applications where both kinds of data need to be processed. Therefore, they help the user, to process both continuous and discrete data.

Basic Computer Configuration

Computer Operations

- The computer is an electronic machine that performs the following five basic operations:
 - Input
 - Process
 - Output
 - Store
 - Control

Basic Computer Configuration

Computer Operations

Input

- It is the process of capturing or acquiring the information, or it is the process of accepting data or information, by using input the computer can do any process.
- Information or data that is entered into a computer or computer device using an **input** device.

Basic Computer Configuration

Computer Operations

Input

- Data is gathered
 - Manually
 - Automatically
 - Both

Basic Computer Configuration

Computer Operations

Types of Computer Input

- **Data**
 - the raw **facts** given to the computer.
- **Programs**
 - the sets of **instructions** that direct the computer.
- **Commands**
 - special codes or **key words** that the user inputs to perform a task.
- **User response**
 - the user's answer to the computer's question.

Basic Computer Configuration

Computer Operations

Processing

- It is the transformation process to convert the input into output.
- A **process** is an instance of running a program.
- It cause the computer to follow instructions from the Memory.
- Perform by **Central Processing Unit (CPU)**.

Basic Computer Configuration

Computer Operations

Processing

- The CPU has three parts:
 - **Arithmetic / Logic Unit (ALU)**
 - **Control Unit**
 - **Input / Output Unit (I/O)**

Basic Computer Configuration

Computer Operations

Processing

Arithmetic / Logic Unit (ALU)

- The part of a computer that performs all arithmetic computations, such as addition and multiplication, and all comparison operations.

Basic Computer Configuration

Computer Operations

Processing

Control Unit

- The control unit is the circuitry that controls the flow of data through the processor, and coordinates the activities of the other units within it.

Basic Computer Configuration

Computer Operations

Processing

Input / Output Unit (I/O Unit)

- The computer components that control input and output devices.

Basic Computer Configuration

Computer Operations

Computer Output

- It is the result, which comes from the transformation process or it is the outcome of the process.
- Anything that comes out of a computer.
- Example:
 - Report
 - Music
 - Graphic
 - Video clip

Basic Computer Configuration

Computer Operations

Types of Computer Output

- **Hard copy**
 - Printed on paper or other permanent media.
- **Soft copy**
 - A **soft copy** is the unprinted digital document file.
 - Displayed on screen or by other non-permanent means.
 - It can be transported from one computer to another.

CSCA0101 Computing Basics

Basic Computer Configuration

Computer Operations

Types of Computer Output

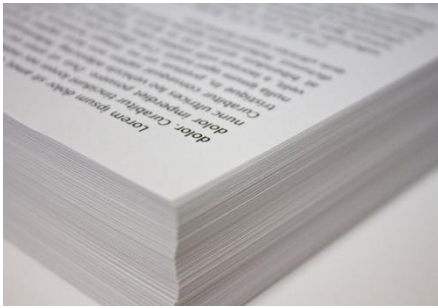

Hard copy



Soft copy

Basic Computer Configuration

Computer Operations

Categories of Output

- **Text documents**
 - reports, letters, memo.
- **Graphics**
 - charts, graphs, pictures
- **Multimedia**
 - combination of text, graphics, video, audio

Basic Computer Configuration

Computer Operations

Storing

- It is the process of storing or retaining the data or information or instructions, so that the user can retain and retrieve it whenever required.
- Capability to store information after processing.
- Storage are used to store programs and data when they are not being used in memory.

Basic Computer Configuration

Computer Operations

Controlling

- It is the process of directing the manner and sequence in which all the operations are to be performed.

Basic Computer Configuration

Hardware vs. Software

- **Hardware** is any part of your computer that has a **physical structure**, such as the computer monitor or keyboard.
- **Software** is any **set of instructions** that tells the hardware what to do. It is what guides the hardware and tells it how to accomplish each task.

Basic Computer Configuration

Basic Computer Components

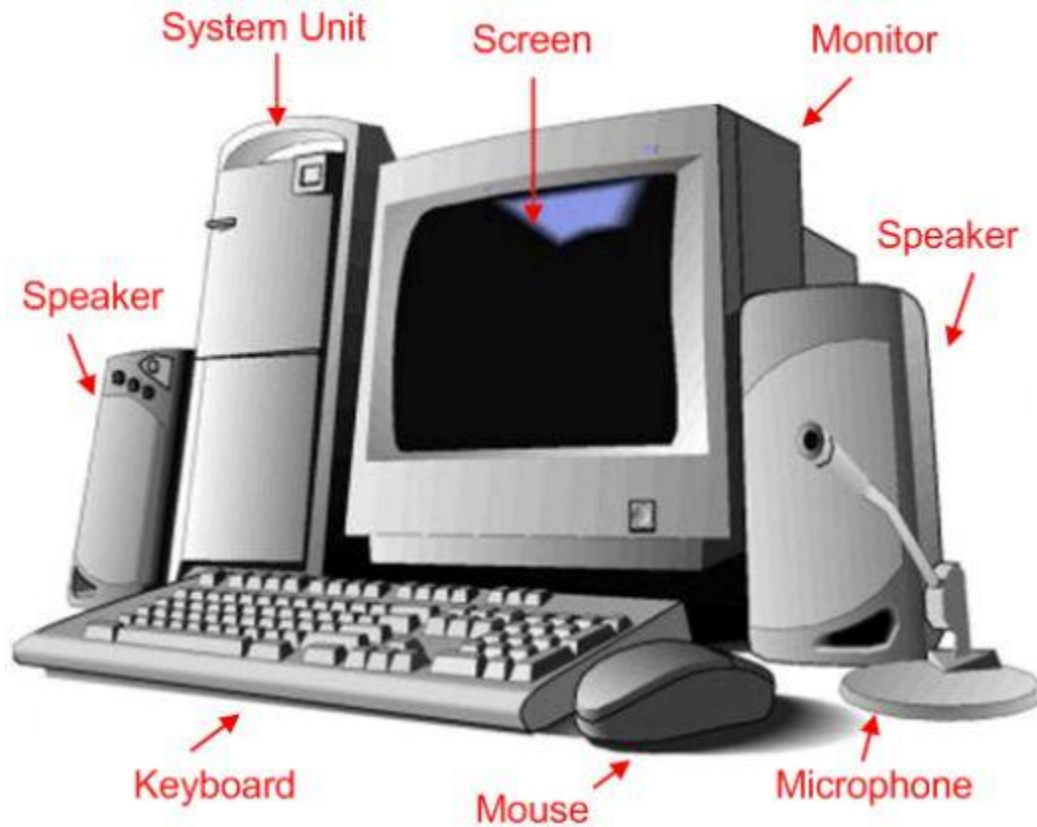

Basic Computer Configuration

Basic Computer Components

System Unit

- The system unit is the core of a computer system.
- The most important of these components is the central processing unit (CPU), or microprocessor, which acts as the "brain" of your computer.
- Another component is random access memory (RAM), which temporarily stores information that the CPU uses while the computer is on.
- Almost every other part of your computer connects to the system unit using cables.

Basic Computer Configuration

Basic Computer Components

Computer Case

- Where all of the components are stored.
- The computer case serves mainly as a way to physically mount and contain all of the actual computer components.
- Cases typically come bundled with a power supply.
- Two types of casing:
 - Tower
 - Desktop

Basic Computer Configuration

Basic Computer Components

Computer Case

- Two types of casing:
 - Tower
 - Desktop
- Desktop and tower computers are two different styles of computer case that use desk space in varying ways.
- Desktop computers are designed to lay flat on the desk, while towers stand upright.

CSCA0101 Computing Basics

Basic Computer Configuration

Basic Computer Components

Computer Case



Tower casing



Desktop casing

Basic Computer Configuration

Basic Computer Components

Power Supply

- Used to send power to all of the other hardware so they can operate.
- Two types of power supply:
 - AT (Advanced Technology)
 - ATX (Advanced Technology Extended)



Basic Computer Configuration

Basic Computer Components

Central Processing Unit (CPU)

- The CPU, or the Central Processing Unit, is the brain of the computer and the single most important chip in the computer.
- The CPU performs the system's calculating and processing.



Basic Computer Configuration

Basic Computer Components

CPU Fan

- Any fan inside a computer case used for cooling purposes.



Basic Computer Configuration

Basic Computer Components

Computer Memory

- Also known as Random Access Memory (RAM)
- **Computer memory** is used to store information in electronic devices.

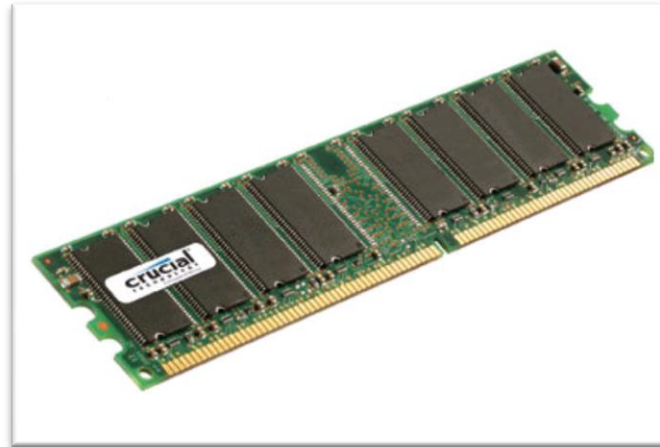

Basic Computer Configuration

Basic Computer Components

Motherboard

- The main circuit board of the computer.
- All key internal and external components of the computer plug into the Motherboard.

Basic Computer Configuration

Basic Computer Components

Motherboard

Components directly attached to the motherboard include:

- **CPU**
- **Chipset**
- **Random-Access Memory (RAM)**
- **Read-Only Memory (ROM)**
- **BIOS** (Basic Input Output System)
- **Buses**
- **Ports**

CSCA0101 Computing Basics

Basic Computer Configuration

Basic Computer Components

Motherboard

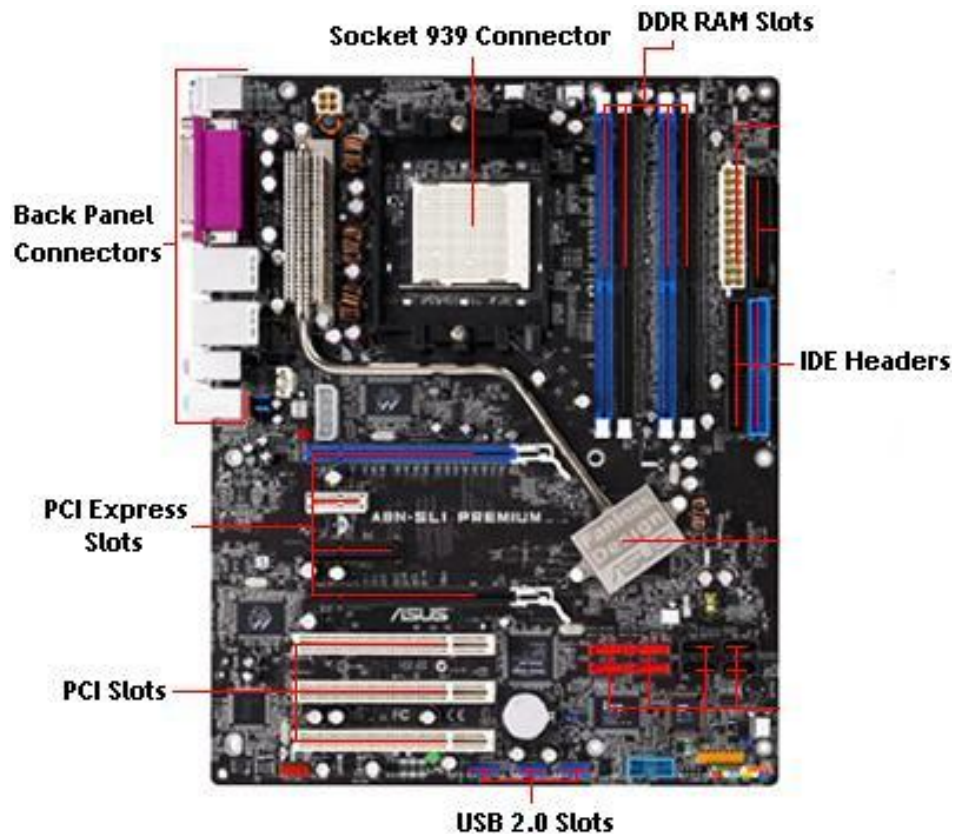

CSCA0101 Computing Basics

Basic Computer Configuration

Basic Computer Components

Motherboard

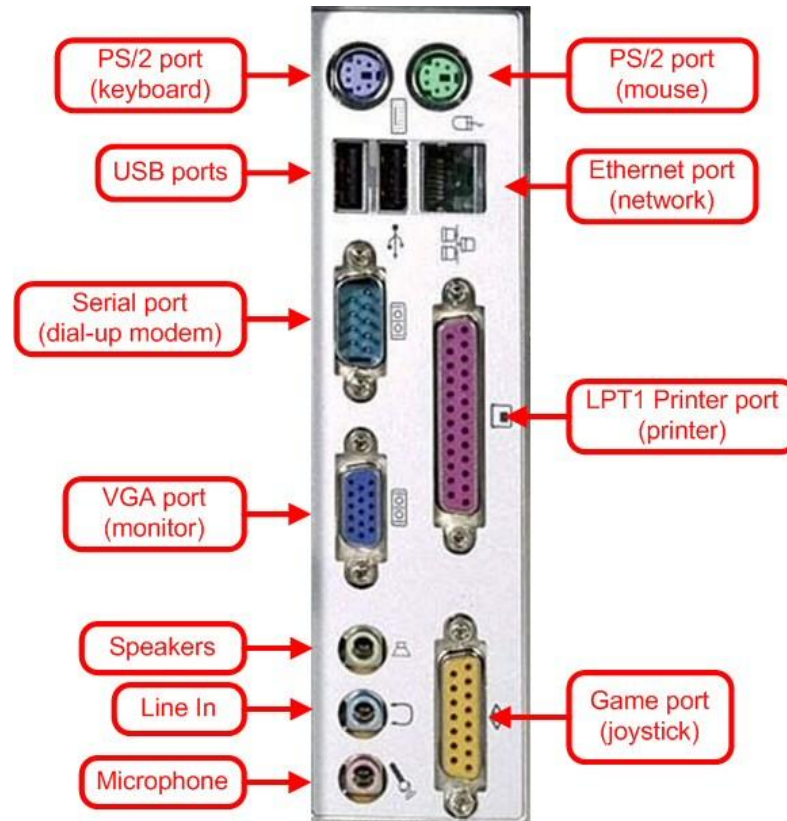

Basic Computer Configuration

Basic Computer Components

Hard disk

- It used to store computer data and program.
- It can hold more data and are faster than floppy disks.



Basic Computer Configuration

Basic Computer Components

Optical Disc Drive

- An optical storage technology that stores and plays back data.
- Some drives can only read from discs, but recent drives are commonly both **readers** and **recorders**.

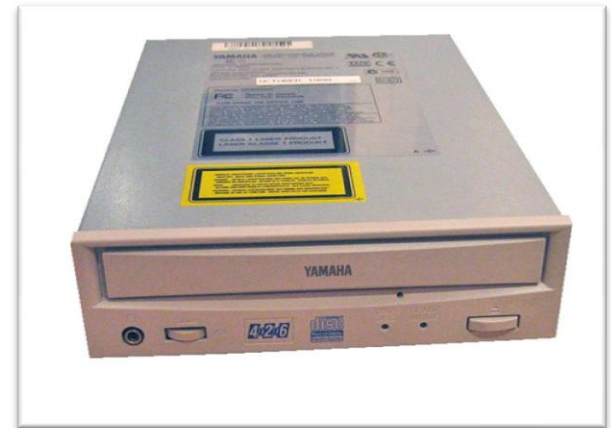

Basic Computer Configuration

Basic Computer Components

Video card

- A board that plugs into a personal computer to give it display capabilities.
- The display capabilities of a computer, however, depend on both the logical circuitry (provided in the video adapter) and the display monitor.



Basic Computer Configuration

Basic Computer Components

Sound card

- A circuit board that plugs into your Motherboard that adds audio capability to your computer, providing high quality stereo output to the speakers.

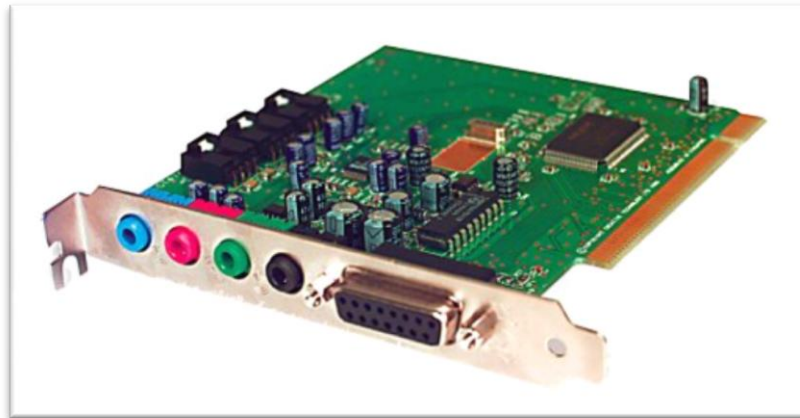

Basic Computer Configuration

Basic Computer Components

Modem

- Short for **modulator-demodulator**.
- A modem is a device or program that enables a computer to transmit data over, for example, telephone or cable lines.



Basic Computer Configuration

Basic Computer Components

Monitor

- The part of a computer that allows you to see what the computer is processing.



Basic Computer Configuration

Basic Computer Components

Other Components

- Input Devices
 - Keyboard, mouse
- Output Devices
 - Printer, speakers
- Operating System
 - Windows, MacOS, Linux

Basic Computer Configuration

Computer Categories

What makes a computer powerful?

- **Speed**
 - A computer can do billions of actions per second.
- **Reliability**
 - Failures are usually due to human error, one way or another.
- **Storage**
 - A computer can keep huge amounts of data.

Basic Computer Configuration

Computer Categories

- Mobile Computer
- Microcomputer
- Minicomputers
- Mainframes
- Supercomputer

Basic Computer Configuration

Computer Categories

Mobile Computer

- **Mobile computing** is human–computer interaction by which a computer is expected to be transported during normal usage.
- Being able to use a computing device even when being mobile and therefore changing location.
- Portability is one aspect of mobile computing.

Basic Computer Configuration

Computer Categories

Mobile Computer

- Example:
 - Personal digital assistant
 - Smartphone
 - Tablet computer
 - Ultra-Mobile PC
 - Wearable computer

CSCA0101 Computing Basics

Basic Computer Configuration

Computer Categories

Mobile Computer



PDA



Smartphone



Tablet PC



Wearable Computer



Ultra-Mobile PC

Basic Computer Configuration

Computer Categories

Microcomputer

- A **microcomputer** is a small, relatively inexpensive computer with a microprocessor as its central processing unit (CPU)
- A small, single-user computer based on one microprocessor.
- Microcomputers are designed to be used by individuals.



Basic Computer Configuration

Computer Categories

Types of Microcomputer

- Tower PC
- Mid-Tower PC
- Mini-Tower PC
- Server
- Workstation
- Personal computer (PC)
 - Desktop
 - Laptop

CSCA0101 Computing Basics

Basic Computer Configuration

Computer Categories

Desktop Vs. Laptop

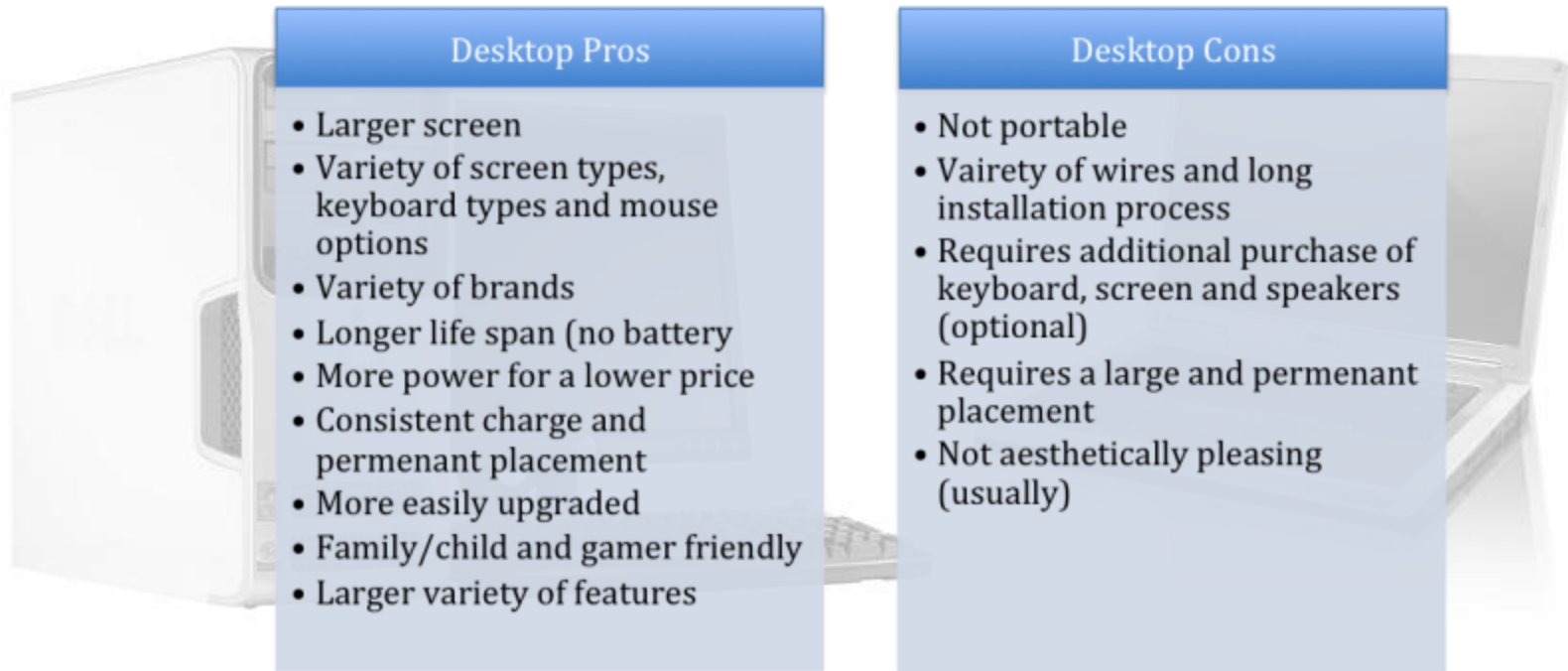

Desktop Pros	Desktop Cons
<ul style="list-style-type: none">• Larger screen• Variety of screen types, keyboard types and mouse options• Variety of brands• Longer life span (no battery)• More power for a lower price• Consistent charge and permanent placement• More easily upgraded• Family/child and gamer friendly• Larger variety of features	<ul style="list-style-type: none">• Not portable• Variety of wires and long installation process• Requires additional purchase of keyboard, screen and speakers (optional)• Requires a large and permanent placement• Not aesthetically pleasing (usually)

CSCA0101 Computing Basics

Basic Computer Configuration

Computer Categories

Desktop Vs. Laptop

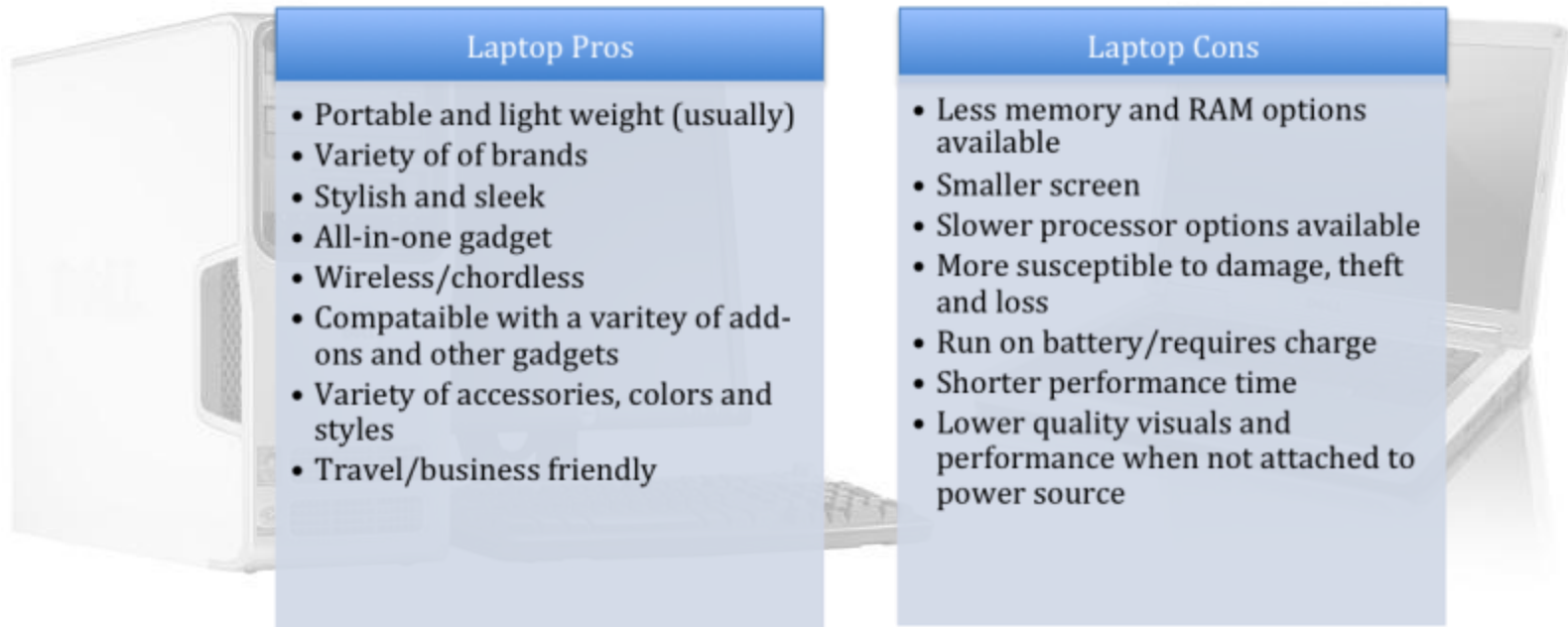

Laptop Pros	Laptop Cons
<ul style="list-style-type: none">• Portable and light weight (usually)• Variety of of brands• Stylish and sleek• All-in-one gadget• Wireless/chordless• Compataible with a varitey of add-ons and other gadgets• Variety of accessories, colors and styles• Travel/business friendly	<ul style="list-style-type: none">• Less memory and RAM options available• Smaller screen• Slower processor options available• More susceptible to damage, theft and loss• Run on battery/requires charge• Shorter performance time• Lower quality visuals and performance when not attached to power source

Basic Computer Configuration

Computer Categories

Laptop vs. Notebook vs. Netbook

	Laptop	Notebook	Netbook
Size	Laptops mostly come in handy sizes ranging from the large briefcase sizes to small handy portables (the screen normally goes from 10.2 inches to 19 inches in diameter).	Notebooks generally come in the sizes of real notebooks to the near PDA sizes. (Exceptions occur as some manufacturer's market their laptops as notebooks)	Netbooks are usually very small in size, ultra-portable devices that replace bulkier laptops.

Basic Computer Configuration

Computer Categories

Laptop vs. Notebook vs. Netbook

	Laptop	Notebook	Netbook
Physical characteristic	A laptop usually weighs between 1.4 to 5.4 Kgs. (3 to 12 pounds)	A Notebook weighs less than 5 pounds and is 3 inches or less in thickness	A netbook weighs between 0.9 Kg to 1.4 Kg.

Basic Computer Configuration

Computer Categories

Laptop vs. Notebook vs. Netbook

	Laptop	Notebook	Netbook
Processing capacity	Laptops are usually associated with higher processing power than notebooks. Normally 1-8 GB RAM.	Notebooks nowadays come in laptop configurations, but the size factor wears off as it becomes more powerful, and the sense of notebook is gone.	Netbooks usually have a lower speed processor This can cause a degraded experience when doing more intensive tasks such as watching movies or playing games. Intel® Atom™ and Intel® Celeron™ processors.

Basic Computer Configuration

Computer Categories

Laptop vs. Notebook vs. Netbook

	Laptop	Notebook	Netbook
Usages	Primary usage is mobility and replicates the usage of a personal computer with extra durability.	primary usage is mobility and personal computer with extra durability	The prime focus is internet access and hence web browsing and emailing gain significance here.

Basic Computer Configuration

Computer Categories

Laptop vs. Notebook vs. Netbook

	Laptop	Notebook	Netbook
Accessories	Can be present in an integrated fashion.	Not integrated. Can be externally attached though.	Netbooks usually do not have integrated DVD drives so that they can be kept lighter.

Basic Computer Configuration

Computer Categories

Laptop vs. Notebook vs. Netbook



Basic Computer Configuration

Computer Categories

Workstation

- A powerful, single-user computer.
- It has a more powerful microprocessor and a higher-quality monitor.
- Can be used as server computers that supply files to client computers over a network.



Basic Computer Configuration

Computer Categories

Workstation Usages

- Engineering applications (CAD/CAM)
- Desktop publishing
- Software development
- Other types of applications that require a moderate amount of computing power and relatively high quality graphics capabilities.

Basic Computer Configuration

Computer Categories

Minicomputer

- A midsized computer.
- In size and power, minicomputers lie between workstations and mainframes.
- A minicomputer is a multiprocessing system capable of supporting hundreds users simultaneously.



Basic Computer Configuration

Computer Categories

Mainframes

- A very large and expensive computer capable of supporting hundreds, or even thousands, of users simultaneously.
- In some ways, mainframes are more powerful than supercomputers because they support more simultaneous programs.
- But supercomputers can execute a single program faster than a mainframe.



Basic Computer Configuration

Computer Categories

Mainframes

- These computers are capable of handling and processing very large amounts of data quickly.
- Mainframe computers are used in large institutions such as government, banks and large corporations.

Basic Computer Configuration

Computer Categories

Supercomputer

- The fastest type of computer.
- Supercomputers are very expensive and are employed for specialized applications that require immense amounts of mathematical calculations.
- An extremely fast computer that can perform hundreds of millions of instructions per second.



Basic Computer Configuration

Computer Categories

Supercomputer

Usages:

- focused on performing tasks involving intense numerical calculations such as weather forecasting, fluid dynamics, nuclear simulations, theoretical astrophysics, and complex scientific computations.