

Chapter – 2 P-H Diagram Refrigeration Cycle Analysis & Refrigerant Flow Diagram

Copy Right By:
Thomas T.S. Wan
温到祥 著
Sept. 3, 2008
All rights reserved

Industrial refrigeration system design starts from P-H Diagram Refrigeration Cycle Analysis and Refrigerant Flow Diagram:

(1) P-H Diagram Refrigeration Cycle Analysis.

P-H Diagram is to analysis the feasibility of the refrigeration cycle, to calculate the thermodynamic properties of the refrigeration system. Use the P-H Diagram analysis, all the refrigerant flow rates and operating conditions at the design point for the system can be clearly determined.

(2) Refrigerant Flow Diagram.

Refrigerant Flow Diagram is show the equipment used for the system, to determine the refrigerant piping between the components; also to determine the pipe sizes, insulation requirement, to determine the pressure drops, suction superheat and etc. The Refrigerant Flow Diagram can be very simple and it also can be expanded to P&ID (Process and Instrumentation Diagram) if required.

The Refrigerant Flow Diagram is to be read in conjunction with the P-H Diagram to get the entire picture of the system.

P-H Diagram Analysis.

FIG. 2-1 shows a typical P-H (Pressure-Enthalpy) diagram for R-22. FIG. 2-2 shows the idea refrigeration cycle imposed on the P-H diagram.

FIG. 2-3 is the image of the refrigeration cycle taken out from FIG. 2-2, but only showing the related data for this idea refrigeration cycle. The vertical Pressure Axis and the horizontal Enthalpy Axis are omitted. The pressures and enthalpy data related to the cycle are shown on the P-H diagram.

Evaporator - Line A-B-C is the evaporative temperature line. The Enthalpy point “B” to Enthalpy point “C” represents the NRE for the system.

Compressor - The Compression line is C-D, it is a line of constant Entropy. The Head of Compression is $H_D - H_C$ (Btu/Lb.). Compression Head (or Adiabatic Head) is also

expressed in Feet, that is $(H_D - H_C) \times 778$. For actual compression, the compression no longer follows adiabatic line and it follows polytropic function as indicated by the line C-D' in FIG. 2-3.

Condensing - The Condenser (Heat rejection) line is D-E or D'-E for actual case. Total heat rejection from the condenser is the sum of heat absorbed from the

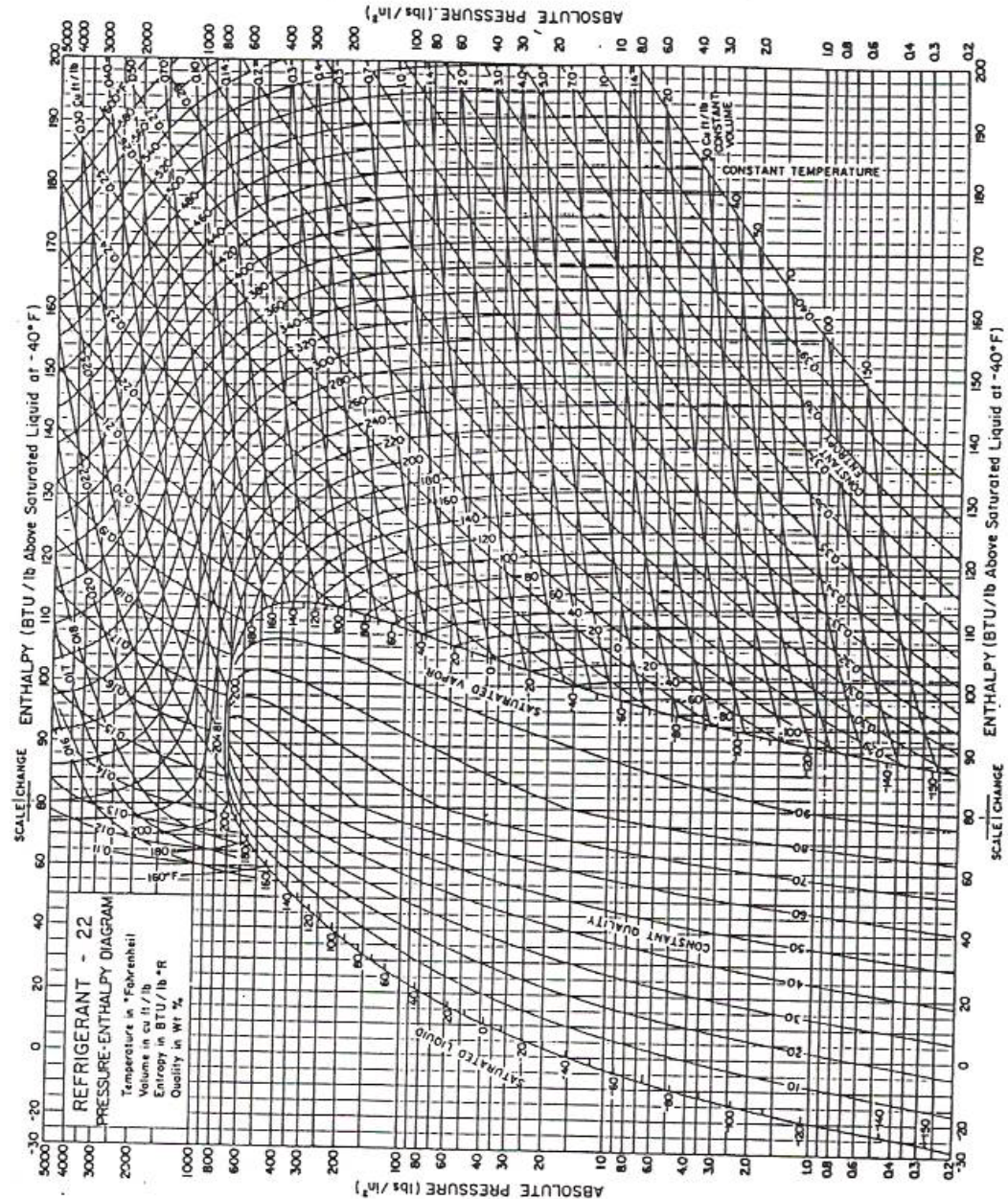

FIG. 2-1 Pressure-Enthalpy Diagram for R-22

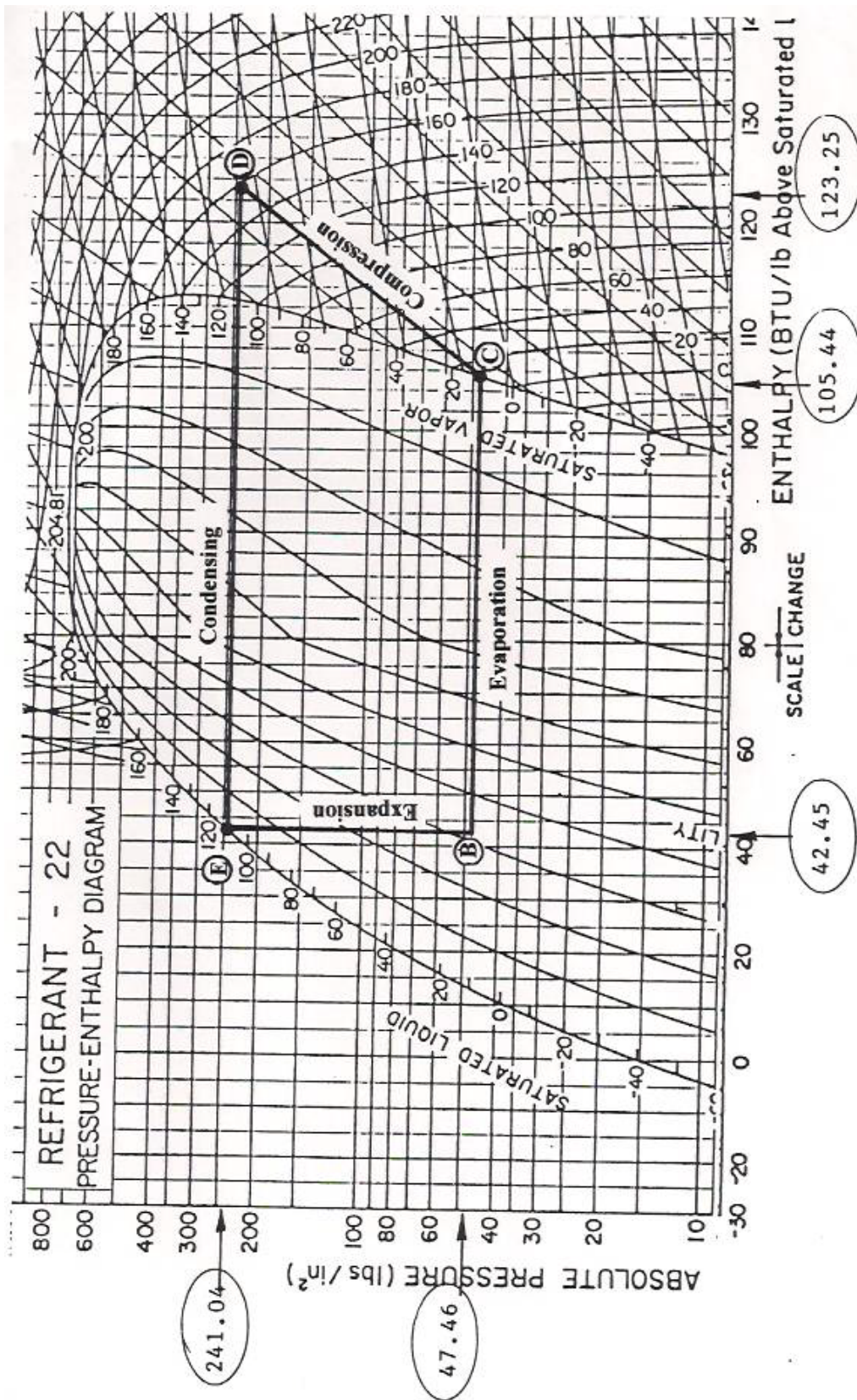

FIG. 2-2 Refrigeration Cycle on Actual P-H Diagram

Compressor Suction Temperature: 10°F
 Compressor Suction Pressure: 47.46 Psia
 Compressor Discharge Pressure: 241.04 Pisa
 Compressor Suction Enthalpy: 105.44 Btu/Lb.
 Compressor Discharge Enthalpy: 123.25 Btu/Lb.
 Refrigerant Liquid Enthalpy: 42.45 Btu/Lb.
 Compressor Suction Entropy: 0.226

For more accurate calculation, it is suggested that all the data are to be taken out from the Refrigerant Property Table or from a Computer Software.

Expansion (Throttling Process) and Flash Gas:

From FIG. 2-3, when the refrigerant liquid leaves the condenser at point “E”; it is a high pressure and high temperature liquid. Through the expansion valve, the liquid is throttling down to point “B”. Under this constant enthalpy process, portion of the liquid is evaporated to cool the liquid down to the temperature at the evaporative pressure line A-C. The percent of the Flash Gas is calculated as the following:

$$\text{Percent of Flash Gas} = \frac{H_B - H_A}{H_C - H_A} \times 100$$

Net Refrigerant Effect:

The remainder amount of the liquid excluding the Flash Gas in the evaporator is the useful effective liquid for refrigeration; the enthalpies difference between C-B is the “Net Refrigerating Effect” (NRE) as shown in the FIG. 2-3.

$$\begin{aligned} \text{Therefore: } \text{NRE} &= \text{Enthalpy at point “C”} - \text{Enthalpy at point “B”} \\ &= H_C - H_B \quad (\text{Btu/Lb.}) \end{aligned}$$

The enthalpy of H_B is the same as the enthalpy of H_E because adiabatic process of Throttling,

$$\text{Therefore: } \text{NRE} = H_C - H_E \quad (\text{Btu/Lb.})$$

Refrigerant Flow Determination:

Refrigeration Ton (TR) is the unit of heat absorbed from evaporator, which is to absorb 12,000 Btu/Hr (or 200 Btu/Min) from the product or the process. The amount of refrigerant flow required to absorb one TR through the evaporator is determined as the following:

$$\text{Flow} = \frac{200}{\text{NRE}} \times \text{TR}$$

Where:	Flow:	Refrigerant Flow, Lbs/Min.
	200:	Heat removal, Btu/Min.
	NRE:	Net Refrigeration Effect, Btu/Lb.
	TR:	Tons of Refrigeration.

$NRE = H_C - H_E$, Therefore:

$$\text{Flow} = \frac{200}{H_C - H_E} \times \text{TR}$$

Suction Gas Superheat:

In the real world, the suction gas at the inlet of the compressor is always superheated. The possible sources of superheat are the heat gain from inside of the heat exchanger, suction piping, suction and liquid heat exchanger if used, and compressor casing. Superheat increases the Entropy of suction gas and increases the compression head for the compressor. The suction superheat is represented by the horizontal constant pressure line on the P-H diagram in FIG. 2-4.

Usually, the suction superheat is not considered as part of the NRE, unless the heat exchanger is purposely designed for it as shown in the case (C) of FIG. 2-4.

Too much suction superheat is not desirable for the refrigeration system due to following reasons:

- (1) Higher suction entropy, higher power consumption for the compressor.
- (2) Increases the suction gas volume, increases the compressor size.
- (3) Higher compressor discharge temperature.

Some of the systems, the suction superheat is extremely high due to the special design of the process heat exchanger. If it is the case, it might be justify by quenching the suction gas with refrigerant liquid.

(A) Suction Superheat at constant pressure

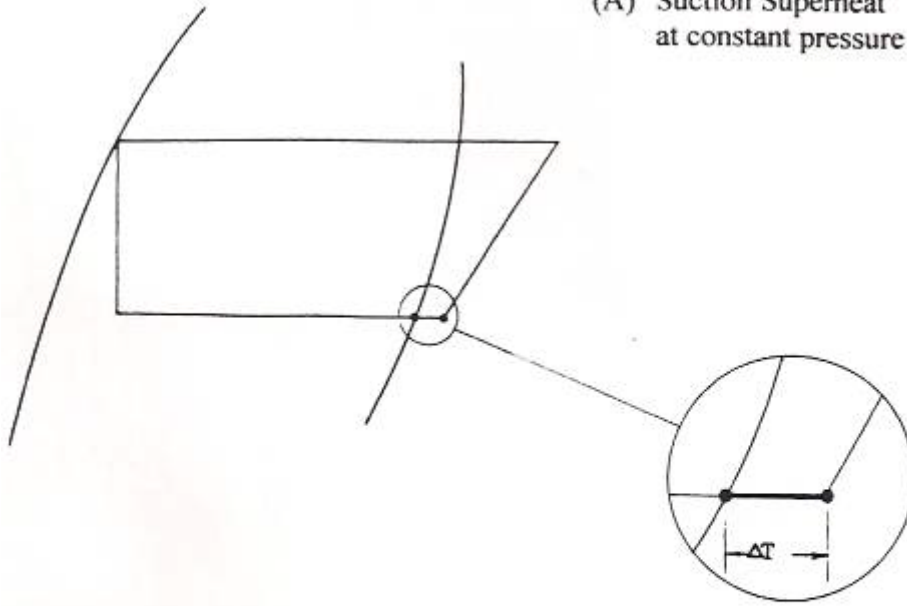

(B) Superheat is not part of NRE

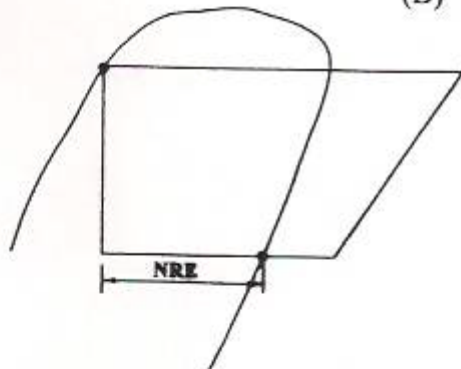

(C) Superheat is part of the NRE

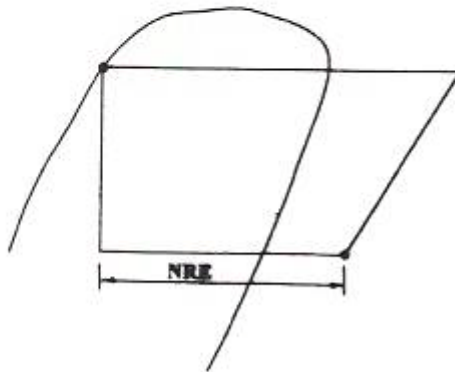

FIG. 2-4 Suction Superheat

Suction Pressure Drop:

Suction pressure drop is represented by the vertical line as shown in the P-H diagram of FIG. 2-5. Suction pressure drop must be allowed for compressor selection.

Pressure drop from the evaporator to the compressor suction exists because of the following:

- (A) The suction pipe line pressure drops including valves, fittings and suction trap.
- (B) Suction valve, strainer and check valve for the compressor.
- (C) Suction gas acceleration.
- (D) Evaporator pressure drop.

Too much suction pressure drop allowance would increase the size of the compressor and increase the design HP. But, too small suction pressure drop would increase the size of the suction piping, fittings and insulation. Therefore, the design allowance for the suction pressure drop should be economically balanced out with the cost for the piping, valves sizes and insulation.

It is important that the suction pressure drop allowance should be expressed in terms of pressure in Psi, not the equivalent of saturated temperature of °F or °C. The value of a ΔP for 2~3°F is much smaller at lower ET than at higher ET.

Suction Penalties:

Suction penalty is the combination of suction superheat and suction pressure drop as shown in FIG. 2-6. Therefore, the suction penalty is not a horizontal, nor a vertical line. The correct expression shall be a slope as shown in the P-H Diagram.

Discharge Penalty:

Compressor discharge pressure is to be higher than the condensing pressure to overcome the pressure resistances in the discharge line. This pressure difference (ΔP) is shown in the P-H Diagram of FIG. 2-7.

Too much discharge pressure drop allowed would increase the power consumption of the compressor. But, too small pressure drop allowance might increase the size of discharge piping and fittings. In any case, the discharge penalty should be allowed for the compressor selection for the proper function of the refrigeration system. For screw compressor application, the ΔP is usually larger than the reciprocating and centrifugal compressors. The ΔP for air cooled or evaporative condenser is larger than the water cooled condenser.

Effect of Compressor Suction and Discharge Penalties:

FIG. 2-8 shows the P-H Diagram for the refrigeration system with the suction and discharge penalties. The compression head which is with penalties (shown in dotted line) is larger than the one without penalties.

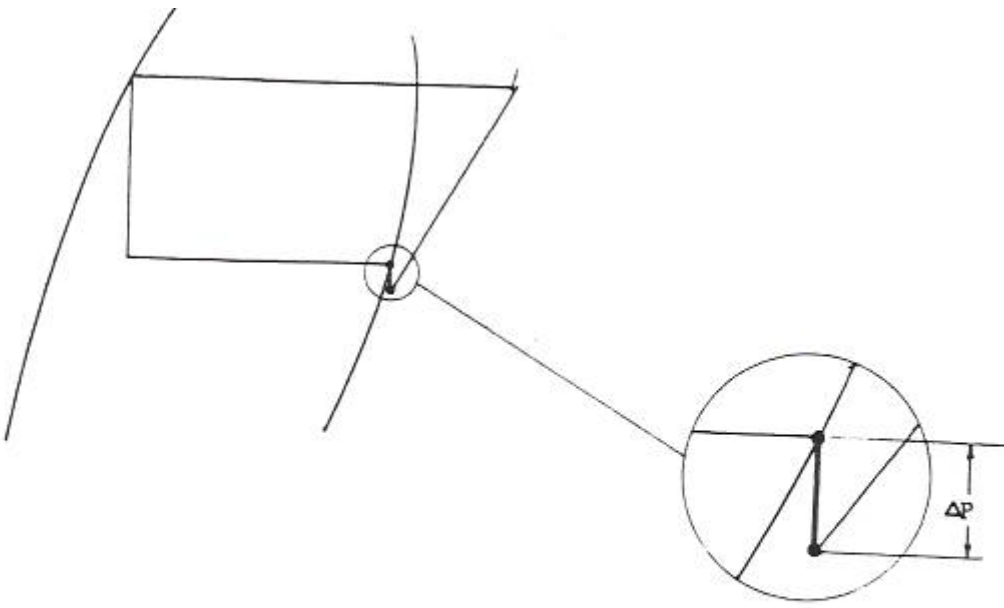

FIG. 2-5 Suction Pressure Drop

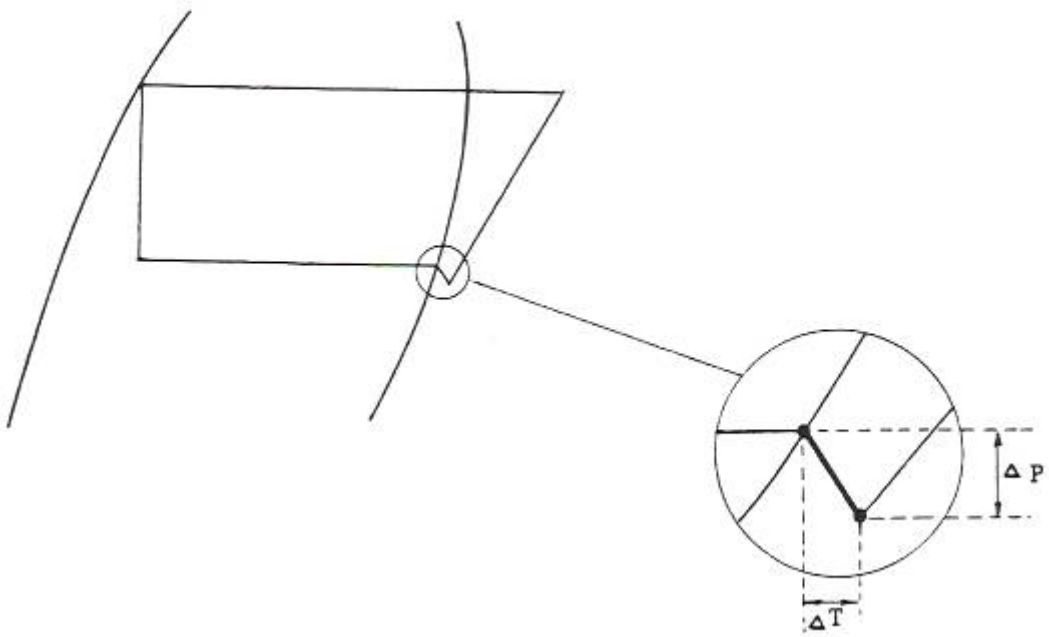

FIG. 2-6 Suction Penalties

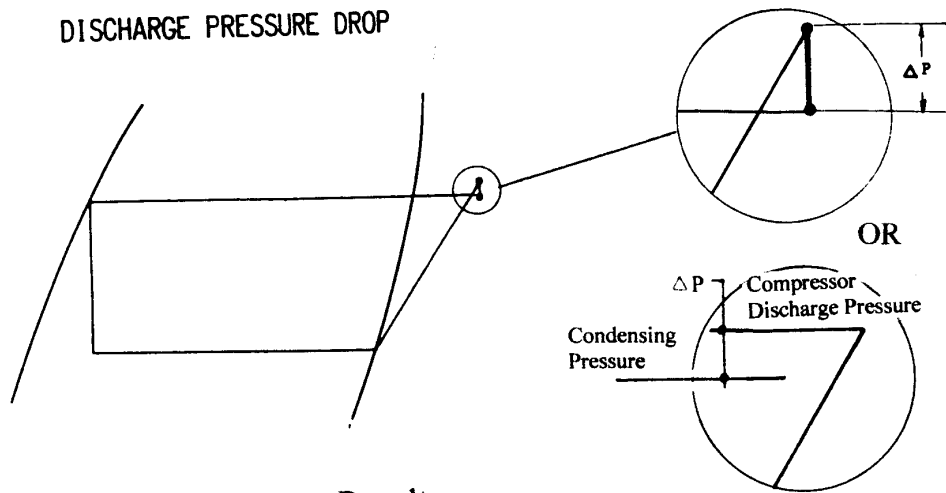

FIG. 2-7 Discharge Penalty

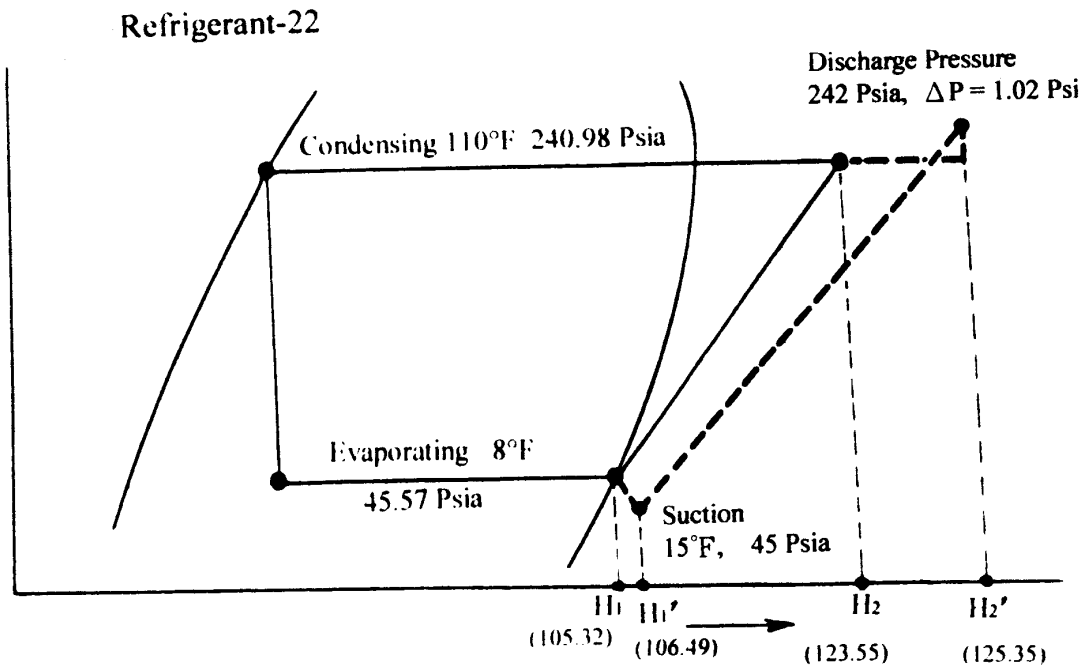

FIG. 2-8 Effect of Suction and Discharge Penalties

FIG. 2-9 shows the Typical P-H Diagram for a Screw System with liquid subcooling economizer; the diagram shows the suction and the discharge penalties which are usually encountered by screw compressor in a refrigeration system.

Both discharge and suction penalties must be included for system design. It exists in the real world. The refrigeration capacity of the system would be under design as much as 10 to 15%, if the compressor is only rated for saturated CT and saturated ET without penalties.

Liquid Subcooling:

FIG. 2-10 (A) shows the Liquid Subcooling on the P-H diagram. If a smaller degree of liquid Subcooling is required by the application, it could be obtained by using cooling water. However, for larger degree of subcooling, it is necessary to include a liquid subcooler.

Liquid Subcooling is one the methods to increase the NRE as shown in the FIG. 2-10 (B). Also, it is used to ensure the liquid supplied to the evaporator is free of flash gas as required by the application, particularly where the liquid line of the installation is with vertical lift.

The relationships Between CT, ET and NRE:

The P-H Diagram of FIG. 2-11 shows the cases of:

- 1.0 NRE decreases and compression head increases when the CT is higher.
- 2.0 The NRE increases and compression head decreases when the CT is lower.

The P-H Diagram of FIG. 2-12 shows the cases of:

- 1.0 NRE increases and compression head decreases when the ET is higher.
- 2.0 The NRE getting smaller and compression head increase at lower ET.

The NRE is changing all the times during system operation even at the full load condition.

Flash Intercooling (Auto-Refrigeration):

The flash intercooling is also a “throttling” process. A saturated liquid is flashed from a higher pressure at point ‘E’ (FIG. 2-13) through a constant enthalpy process, down to a lower saturated temperature point ‘B’. Portion of the liquid is evaporated to cool the remainder liquid; this flash intercooling function is also called auto-refrigeration. The percent of the Flash Gas is calculated as the following:

$$\text{Percent of Flash Gas} = \frac{H_B - H_A}{H_C - H_A} \times 100$$

Take an example for the case of flash intercooling shown in the P-H diagram of FIG. 2-13, the refrigerant is R-22, the enthalpy for each point is shown, if a flow of 200

**P-H DIAGRAM
& PRESSURE DROPS
SCREW COMPRESSOR**

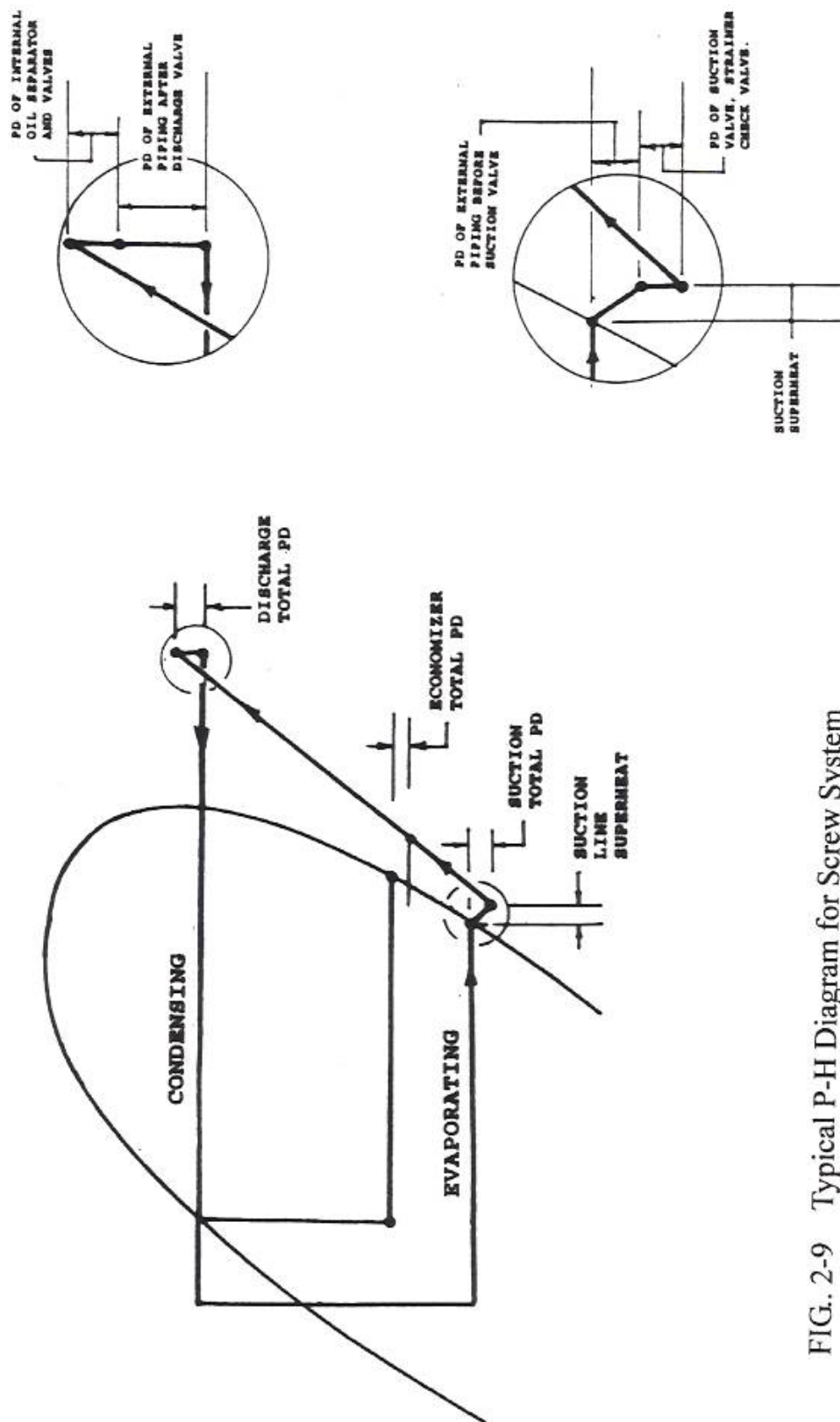
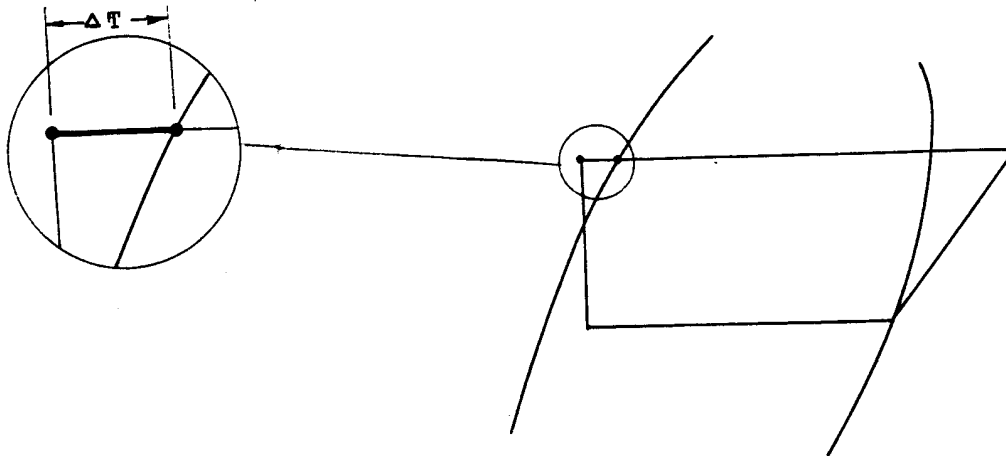

FIG. 2-9 Typical P-H Diagram for Screw System

(A) Liquid Subcooling on P-H Diagram



EFFECT OF LIQUID SUBCOOLING

(B) Effect of Liquid Subcooling

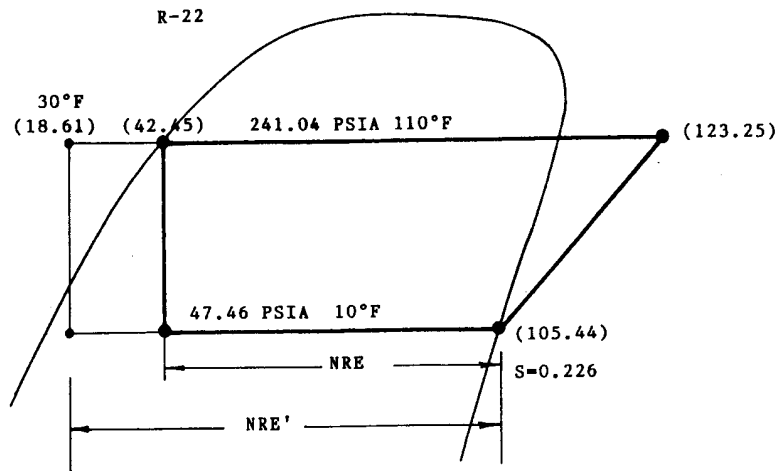

NET REFRIGERANT EFFECT CHANGES:

$$NRE = 105.44 - 42.45 = 62.99 \text{ BTU/LB OF R-22}$$

$$NRE' = 105.44 - 18.61 = 86.83 \text{ BTU/LB OF R-22}$$

FIG. 2-10 Liquid Subcooling

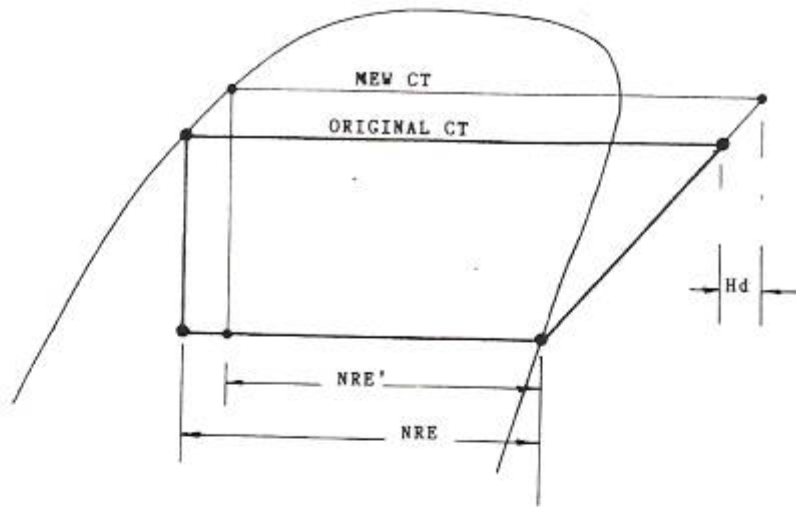

- A. NRE DECREASES.
- B. COMPRESSION HEAD INCREASES.

EFFECT OF LOWER CONDENSING TEMPERATURE

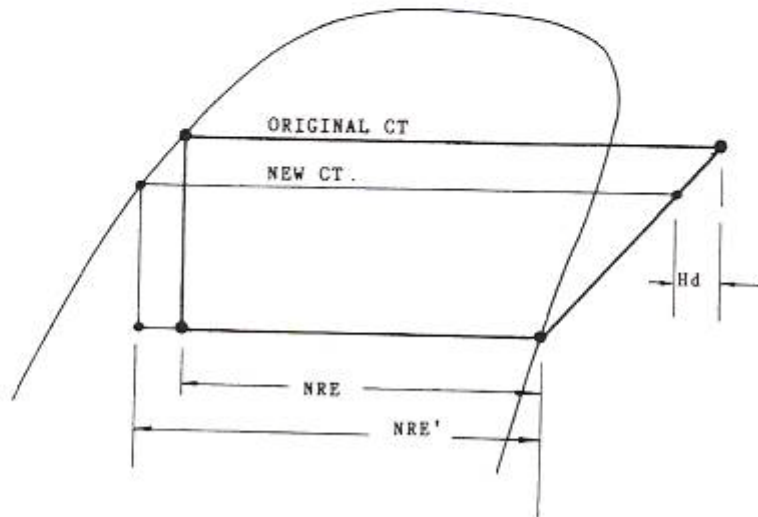

- A. NRE INCREASES.
- B. COMPRESSION HEAD DECREASES.

FIG. 2-11 Effect of NRE with Condensing Temperature

EFFECT OF HIGHER EVAPORATIVE TEMPERATURE

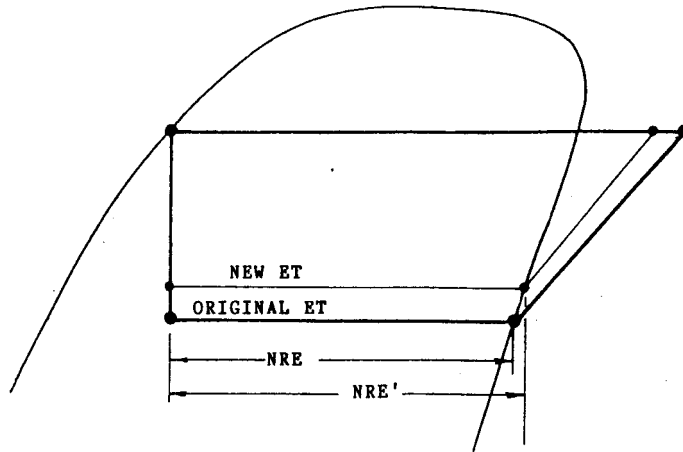

- A. NRE INCREASES.
- B. COMPRESSION HEAD DECREASES.

EFFECT OF LOWER EVAPORATIVE TEMPERATURE

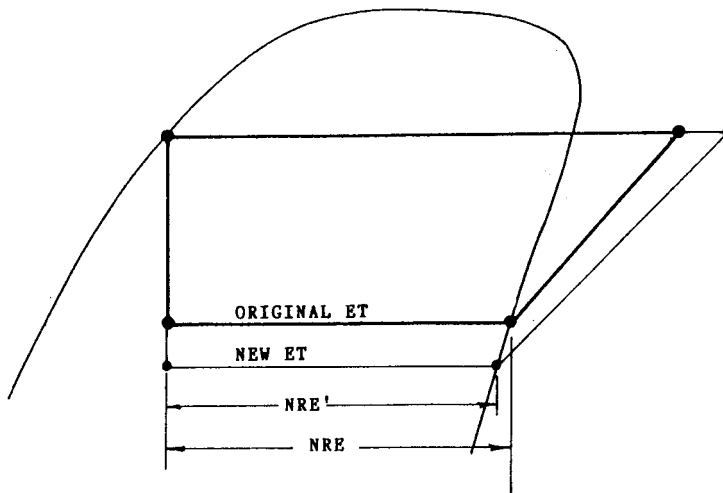

- A. NRE DECREASES.
- B. COMPRESSION HEAD INCREASES.

FIG. 2-12 Effect of NRE with Evaporative Temperature

Flash Intercooling (Auto-Refrigeration):

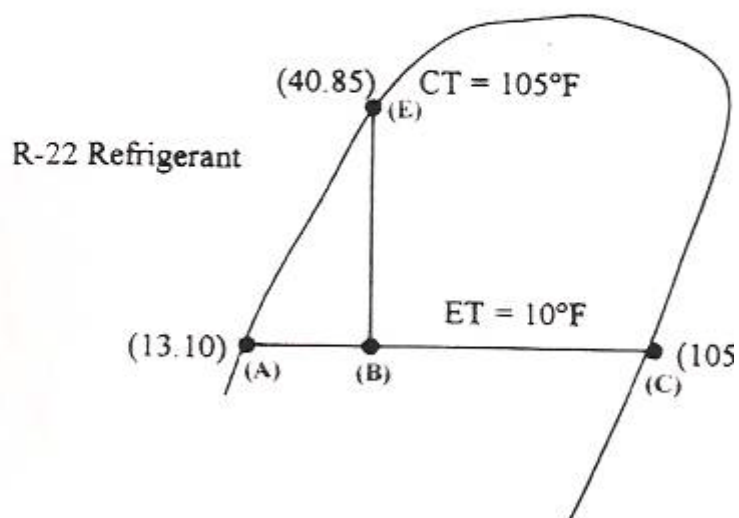

FIG. 2-13 Flash Intercooling (Auto-Refrigeration)

Lbs/Min liquid at 105°F is throttling through a float valve down to a pressure of 10°F saturated level; the gas and liquid flow at the 10°F interstage level are as the following:

$$\begin{aligned} \text{Flash Gas Flow} &= \frac{40.85 - 13.10}{105.44 - 13.10} \times 200 \\ &= 60.10 \text{ Lbs/Min} \end{aligned}$$

$$\text{Liquid Flow at } 10^\circ\text{F} = 200 - 60.10 = 139.9 \text{ Lbs/Min}$$

Power Consumption Calculation:

For power consumption calculation, the enthalpy point for compressor suction and

discharge should include the penalties. Therefore, the compression head shall be H_2' and H_1' instead of H_2 and H_1 as shown in FIG. 2-8. The compression head shall be in Ft. instead of Btu/Lb for power consumption calculation:

$$\text{Head} = (H_2' - H_1') \times 778 = \text{Ft.}$$

$$\text{Compressor HP} = \frac{\text{Flow} \times \text{Head}}{33000 \times E_{\text{ff}}}$$

Where: Flow: Refrigerant Flow, Lbs/Min.
 Head: Compression Head, Ft.
 E_{ff} Compressor Overall Efficiency

Refrigerant Flow Diagram

The main purpose of having Refrigerant Flow Diagram is to show:

- (a) Refrigerant flows and the operating conditions for the system.
- (b) The piping connections between main components for the refrigeration system.
- (c) Type of compressor, condenser, evaporator and etc. are used for the system.
- (d) Valves and other accessories for the system.
- (e) Other important associate components such as suction trap, oil separator and etc. for the proper function of the system.

The Refrigerant Flow Diagram can be very simple just to show the main piping arrangement between the major components or could be complicated as P&ID.

FIG. 2-14 shows a simple Refrigerant Flow Diagram and the correspondent P-H Diagram for the system. The P-H Diagram is showing part of the operating conditions for the refrigeration cycle.

The Refrigerant Flow Diagram shown in FIG. 2-14 is a simple diagram and yet it conveys the messages of the following:

- A. It is a brine chilling refrigeration system.
- B. The compressor is a screw and it is completed with oil separator.
- C. Compressor is with suction stop valve, strainer and check valve.
- D. Discharge check and stop valve are used.
- E. It is with a water cooled, horizontal shell-and-tube condenser.
- F. The condenser is with a Marine Water Box.
- G. DX type brine chiller is used with expansion valve, solenoid valve, strainer and check valve.
- H. High pressure receiver with full length sight glass.
- I. Receiver equalizer.

- J. System drier-filter and liquid sightglass.
- K. Charging, purge valves and pressure relief valves.

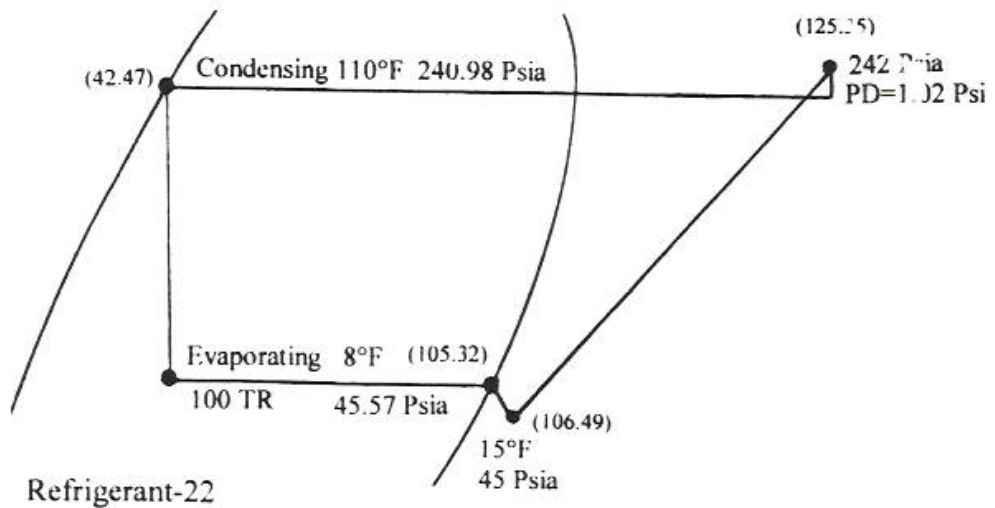
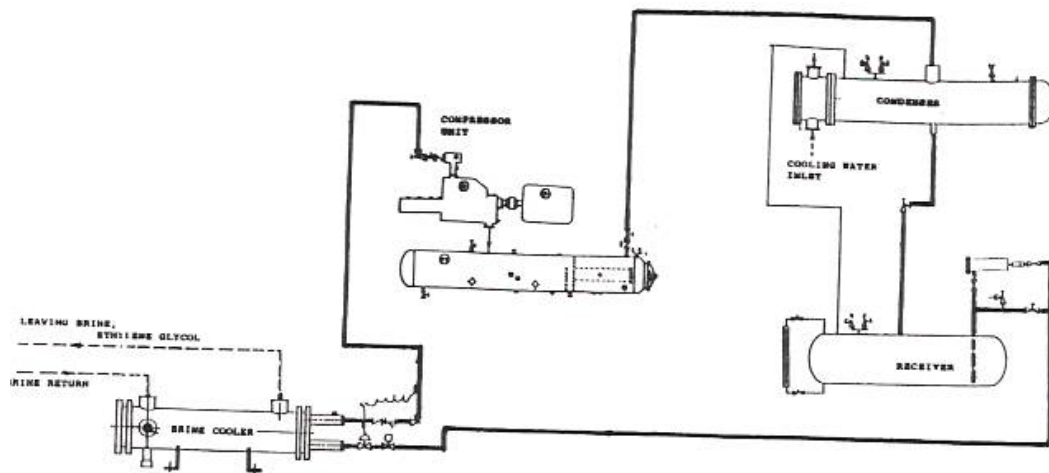

FIG. 2-14 P-H Diagram & Refrigerant Flow Diagram
 DX Brine Chilling System

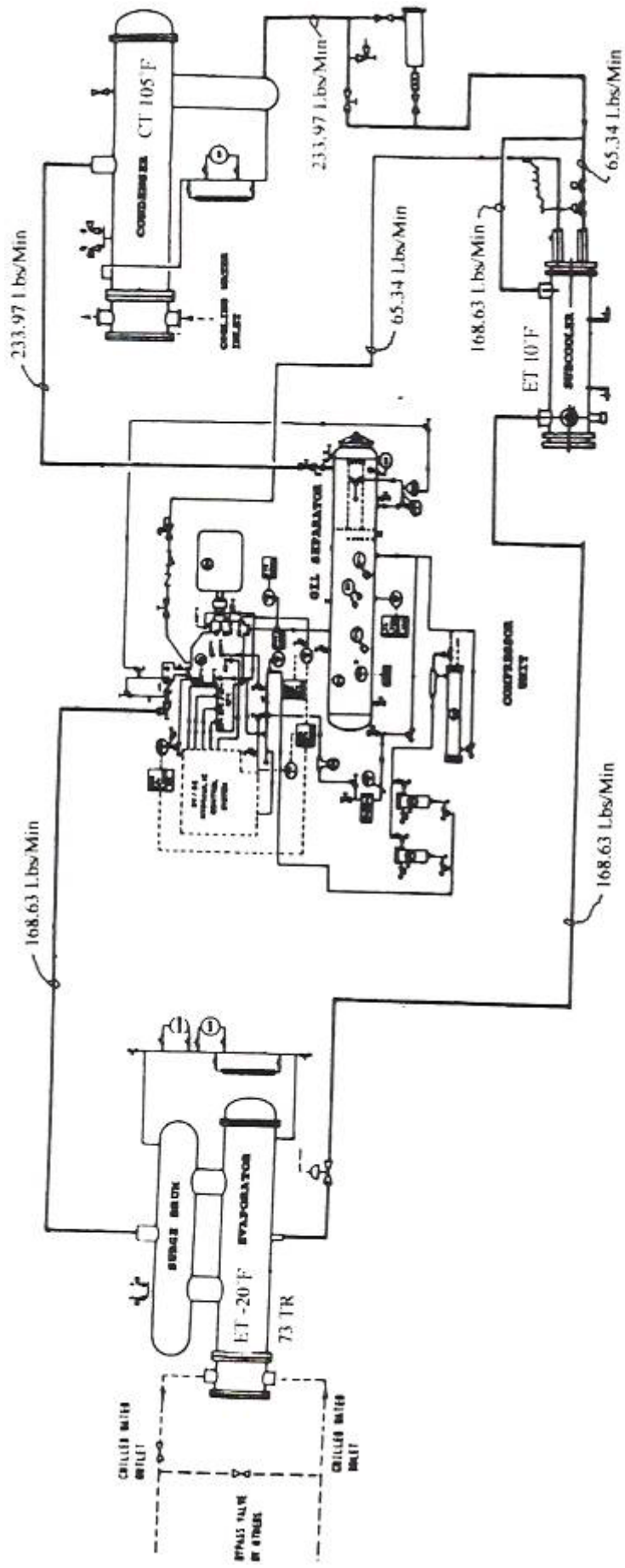

FIG. 2-15 Refrigerant Flow Diagram-Screw System

Summary of P-H Analysis and Refrigerant Flow Diagram

The FIG. 2-15 is the typical Refrigerant Flow Diagram. FIG. 2-16 is the typical P-H Diagram for a refrigeration system. The Refrigerant Flow Diagram shows that the refrigeration system is a screw brine chilling with water cooled condenser, liquid subcooling economizer and the evaporator is a shell-and-tube flooded design with surge drum; water cooled oil cooling system is also shown for the screw compressor.

For practical use purpose, the P-H Diagram and the Refrigerant Flow Diagram shown in FIG. 2-15 and FIG. 2-16 are well enough for system design application.

22 REFRIGERANT

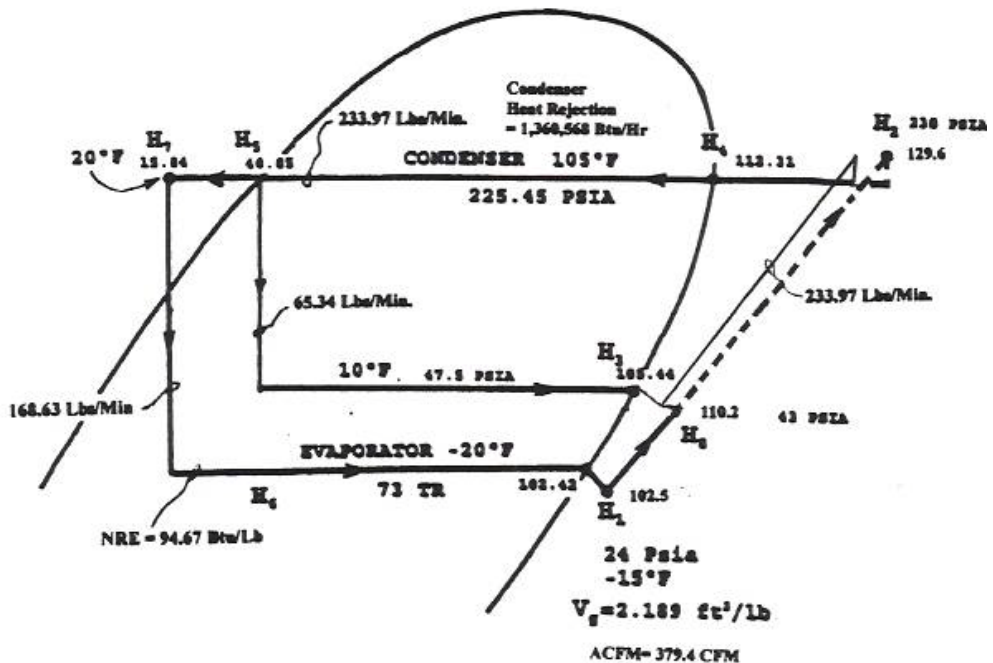

FIG. 2-16 P-H Diagram- Screw System